



M157570E.1

ITEM NUMBER: 157570

SERIAL NUMBER: _____

OWNER'S MANUAL
Instructions for Set-up, Operation, Maintenance, & Storage
DUAL GUN HOT WATER/STEAM PRESSURE WASHER 3000 PSI/8 GPM
 (Hereafter referred to as hot water pressure washer.)
PORTABLE OUTDOOR – USE ONLY

This pressure washer produces both cold and hot water high-pressure spray. Cleaning chemicals may be incorporated into the spray if desired. The pressure pump for this equipment is powered by a diesel engine and the water is heated by a diesel/kerosene/fuel-oil fired, open flame burner.

⚠ WARNING – READ THIS MANUAL

READ and UNDERSTAND this Owner's Manual and the Engine Owner's Manual completely before attempting to set up and use the pressure washer! Failure to properly set up, operate, and maintain this pressure washer could result in *serious injury or death* to operator or bystanders.

⚠ WARNING – SPECIAL HAZARDS

CO Poisoning	<ul style="list-style-type: none"> • Exhaust from both the engine and burner contains carbon monoxide, a poisonous gas that can cause carbon monoxide poisoning and possible death if inhaled. Operate OUTDOORS and at least 20 feet from the home, away from windows, vents, and air intakes, to allow proper ventilation. If you start to feel sick, dizzy, or weak while using the pressure washer, shut off the engine and get to fresh air RIGHT AWAY.
Skin/Eye Injury	<ul style="list-style-type: none"> • High-pressure spray can cause serious skin or eye injury, including injection injury if fluid pierces the skin. Injection injury can result in blood poisoning and/or severe tissue damage.
Burns	<ul style="list-style-type: none"> • Hot spray can scald and burn skin. • Hot surfaces of wand, engine, and burner, as well as hot exhaust from both the engine and burner can cause burns.
Slips/Falls	<ul style="list-style-type: none"> • Spray discharge can cause puddles and slippery surfaces. • Spray-gun kickback can cause operator loss of balance and fall.
Flying Debris	<ul style="list-style-type: none"> • High-pressure spray can cause surface damage and flying debris.
Fire/ Explosion	<ul style="list-style-type: none"> • Engine and burner sparking can ignite fuel or other flammable liquids or vapors in the vicinity. • Hot exhaust from engine and burner can ignite combustible materials.
Chemical Exposure	<ul style="list-style-type: none"> • Cleaning chemical vapors or contact with skin may be hazardous.
Electric Shock	<ul style="list-style-type: none"> • Spray contact with electrical sources can cause electric shock.

A summary of important safety information is provided at the end of the manual.

Hazard Signal Word Definitions



This is the safety alert symbol. It is used to alert you to potential personal injury hazards. Obey all safety messages that follow this symbol to avoid possible injury or death.

⚠ DANGER

DANGER indicates a hazardous situation, which if not avoided, will result in death or serious injury.

⚠ WARNING

WARNING indicates a hazardous situation, which if not avoided, could result in death or serious injury.

⚠ CAUTION

CAUTION used with the safety alert symbol, indicates a hazardous situation, which if not avoided, could result in minor or moderate injury.

CAUTION

CAUTION without the safety alert symbol, is used to address practices not related to personal injury.

NOTICE

NOTICE is used to address practices not related to personal injury.

EQUIPMENT PROTECTION QUICK FACTS

Inspect Upon Delivery	STOP! Inspect to make sure no components are missing or damaged. See the Assembly and Initial Set-Up section for instructions on whom to contact to report missing or damaged parts.	
Check Engine Oil	Engine is shipped with oil. Check the engine oil level before starting the pressure washer.	
Check Pump Oil	Pump is shipped with oil. Check the pumps oil level before starting.	
Battery Required	A battery is included, but not connected. The engine will not run unless the battery is connected. If replacing, purchase a 12 Volt, minimum 24 Amp/Hr. standard top post mount automotive (Group 75/86).	
Water Flow Requirements	Make sure your supply water flow rate is 20% higher than the pressure washer's flow rate (see "Specifications" section for detail), and that your water is clean and particle free.	
Storage	Do not allow water to freeze in the pump, hose, coil, or spray gun(s).	
Chemical Spraying	Use only NorthStar brand or equivalent pressure washer chemicals designed for high-pressure washer use. Use soap adjustment knob to regulate cleaning power if applicable.	
Maintenance Schedule	Engine:	<ul style="list-style-type: none"> See Engine's Owner's manual.
	Pump:	<ul style="list-style-type: none"> Change oil after first 40 hours, then every 3 months or 500 hours.
	Burner Fuel Filter /Water Separator:	<ul style="list-style-type: none"> Drain water as needed. Change filter after every 500 hours of use.
	Coil:	<ul style="list-style-type: none"> Descale coil annually or more frequently as conditions/performance require. Inspect coil for soot build-up annually and desoot if needed.
	Electrodes:	<ul style="list-style-type: none"> Inspect electrodes annually and clean/adjust as needed.
	Belts:	<ul style="list-style-type: none"> Check belt tension after the first 24 hours of use, then routinely with each oil change. Tighten or change belts as needed.

Table of Contents

Important Safety Information	4
Specifications	5
Component Identification	6-7
Safety Labeling	8-9
Special Equipment Safety Features	10
Assembly & Initial Set-Up Instructions	11-15
Moving & Towing the Pressure Washer	16
Before Each Use	17-20
Operating the Pressure Washer	21-28
Storing the Pressure Washer	29-30
Maintenance & Repair	31-40
Major Components	41
Parts Explosion (Heat Exchanger/Blower)	42-45
Parts Explosion (Pump, Engine, & Generator Head)	46-52
Parts Explosion (Skid) (Roll Cage)	53-63
Parts Explosion (Generator Head)	64
Parts Explosion (Pump)	65-66
Schematic Drawing	67-72
Summary of Important Safety Information	73-76
Limited Warranty	77-78

Important Safety Information

Thank you for purchasing a NorthStar PROSHOT Brand Hot Water Pressure Washer. Your machine is designed for long life, dependability, and the top performance you demand. This pressure washer is designed to:

- 1) Produce a high-pressure spray of heated or unheated water (up to 8 gallons per minute at 3000 psi.)
- 2) Cleaning chemicals can be incorporated using a low-pressure water spray.

Water is to be supplied to the pressure washer via an external water tank. The water tank is to be customer supplied. The water supply must have a flow rate of at least 9.6 gallons per minute. Any cleaning chemicals that are used must be specifically approved for use in pressure washers.

The pump is powered by a diesel-fueled engine. The spray water is heated (when desired) by a kerosene/diesel/fuel-oiled, spark-ignited, open flame burner. Normal operation of this equipment will require you to supply:

- Diesel fuel and lubrication oil for the engine.
- Water.
- Fuel for the burner (kerosene, diesel, or fuel oil).
- Standard top post mount automotive (Group 75/86) battery.
- Chemical (if desired).

See the “**Specifications**” section of this manual for more detail.

Engine powered pressure washers are for OUTDOOR USE ONLY. Be sure to read about site selection for running this pressure washer in the “**Before Each Use**” section of this manual.

The operator should acquire and wear safety apparel during operation of this pressure washer. Safety apparel includes waterproof insulated gloves, safety goggles, non-slip protective footwear, and ear protection. Some cleaning chemicals may require the use of a respirator mask (as instructed on chemical label).

Before using this pressure washer, the operator shall determine the suitability of this product for its intended use and assumes liability therein.

READ THIS MANUAL

▲ DANGER

Carefully read and follow all instructions and safety information for using this pressure washer. Improper use or maintenance of the pressure washer can result in *serious injury or death* to the operator or bystanders from:

- **Carbon monoxide poisoning**
- **Fire/explosion**
- **Chemical exposure**
- **Skin/eye injury from high pressure spray**
- **Burns**
- **Slips/falls**
- **Electric shock**
- **Flying objects/debris**

Keep this manual for reference and review. A summary of important safety information can be found at the end of the manual.

Proper preparation, operation, and maintenance of this pressure washer will result in optimal performance and a long life for this equipment.

For detailed engine operation and maintenance information, always refer to the engine Owner's Manual furnished with the pressure washer.

ATTENTION:

Rental companies and private owners who loan this equipment to others, please read this manual!

All persons to whom you rent/loan this pressure washer must have access to and read this manual. Always keep this owner's manual with the pressure washer and advise all persons who will operate the machine to read it. You must also provide personal instruction on how to safely set-up and operate the pressure washer and remain available to answer any questions a renter/borrower might have.

Specifications

MODEL	
Model #	157570
FLOW OUTPUT	
Pressure Rating	3000 psi
Flow Rate	8 gallons per minute
Maximum Temperature	250° F
DIMENSIONS / COMPONENTS	
Length	48"
Width	60"
Height	56"
Weight	1320 lbs.
Pump Model	General Pump TSF2219
Engine Model	Kubota V1505
Engine Horsepower	24.8 HP
High Pressure Discharge Hose	(2) 3/8" x 50'
Chemical Injector	Maximum dilution ratio 18:1
Battery	12 Volt, minimum 24 Amp/Hr. Standard top post mount automotive (Group 75/86) The inside dimensions of the battery compartment are 11-1/8"L x 7-3/4"W x 10-1/8"H.
SUPPLIES REQUIRED	
Engine Fuel	Diesel (Capacity: 16 Gal.)
Engine Oil	See Engine's Owner's Manual
Burner Fuel	#1 or #2 Diesel, B5 or lower Biodiesel, Kerosene, or Fuel Oil (Capacity: 16 Gal.)
Pump Oil (shipped with oil, but refills required)	33.8 ounces SAE Non-detergent 30wt. capacity
Input Water Supply (Tank Feed)	200-gallon tank recommended (customer supplied). Flow rate must be maintained at 9.6 gpm
Input Water Supply (Tap Feed)	Standard garden hose with inside diameter at least 5/8" (at least 3/4" diameter if hose longer than 100 ft.) Flow rate must be maintained at 9.6 gpm

Component Identification

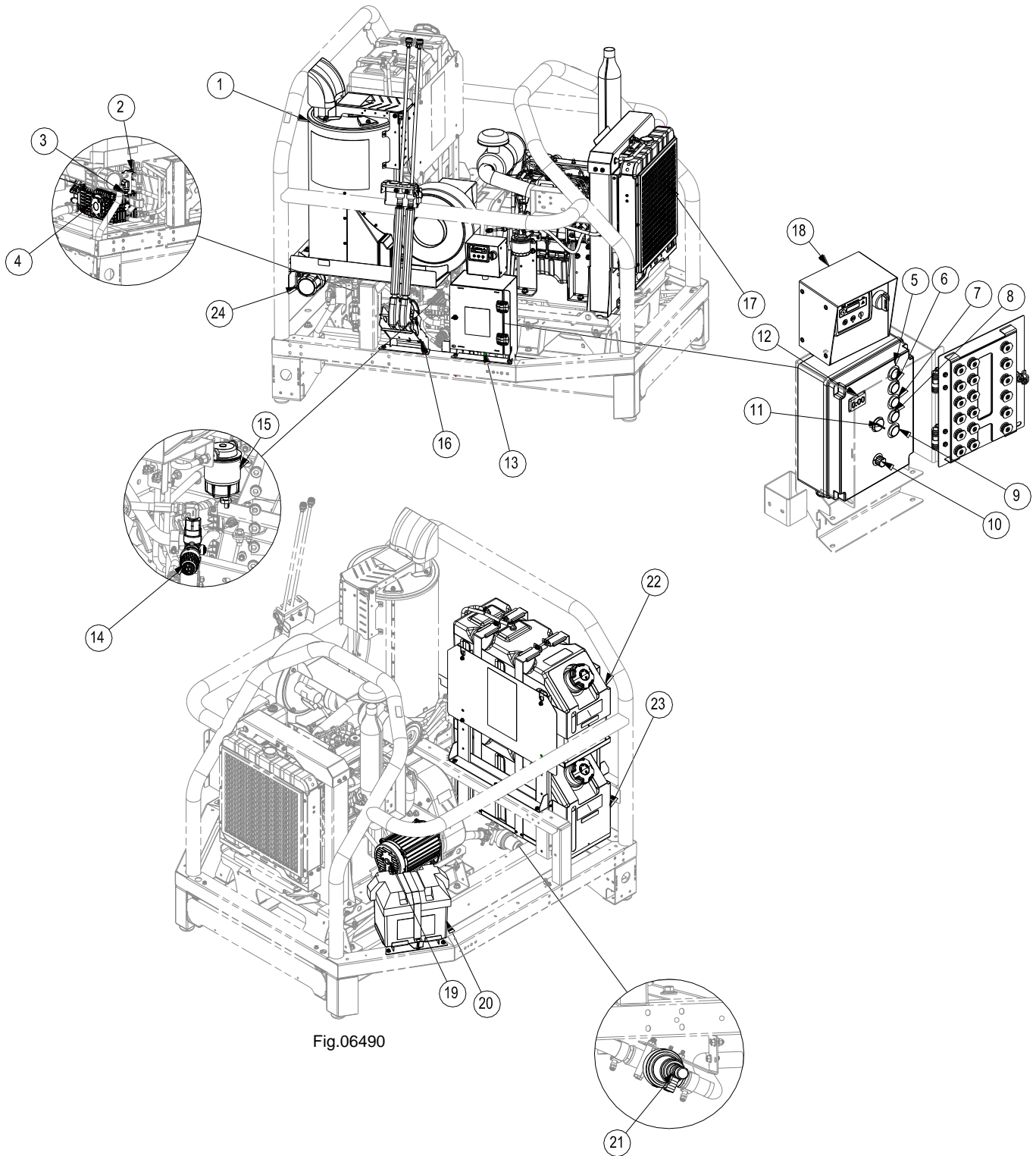

Fig.06490

Component Identification

COMPONENT REFERENCE GUIDE

REF#	NAME	DESCRIPTION
1	Heat Exchanger	Device that heats the water by forcing a flame across steel pipe.
2	Hi-PSI Switch	This is a backup safety feature. If the system pressure exceeds the set pressure limit this device will stop the burner from firing.
3	Water Outlet	Connection point for the high-pressure hose.
4	Pump	The device that moves fluid through a combination of suction and displacement.
5	Indicator Light (Heat)	Instrument used to monitor unit operation. Will illuminate when the burner has power when heat switch is in the ON position.
6	Indicator Light (Spraying)	Instrument used to monitor unit operation. Will illuminate when the gun trigger is being squeezed and water is flowing through the spray gun.
7	Indicator Light (Thermostat)	Instrument used to monitor unit operation. Will illuminate when the gun trigger is being squeezed and water is heating.
8	Indicator Light (Burner Motor)	Instrument used to monitor unit operation. Will illuminate when the blower is operating properly.
9	Indicator Light (Ignition)	Instrument used to monitor unit operation. Will illuminate when burner is firing.
10	Thermostat Knob	Turn to adjust water temperature.
11	Heat Switch	On/Off device for power to burner components.
12	Hour Meter	Indicates the number of hour's the pressure washer has been used.
13	Control Box	Mounted housing that holds electrical controls for the burner. Storage location for nozzles.
14	Unloader	Valve that regulates pressure and directs flow into bypass when trigger is released.
15	Burner Fuel Filter/ Water Separator	Used to remove contaminant water from burner fuel to prevent water in the fuel from reaching the burner.
16	Gun Mount	Location to secure up to 3 spray guns.
17	Engine (see engine's owner's manual)	The air-cooled engine powers the pump and generator.
18	Engine Control Module	Module for starting and stopping engine. See detailed starting and stopping instruction in the operations section of this manual.
19	Generator	Powers burner components with 120V AC electricity.
20	Battery Box	Storage compartment to house the battery.
21	Water Inlet	Used to connect water from the feed tank to the inlet plumbing.
22	Diesel/Kerosene/Fuel Oil	Burner fuel storage container.
23	Engine Fuel Tank	Engine fuel storage container.
24	Manual Tube	Storage location for Owner's Manual.

Safety Labeling

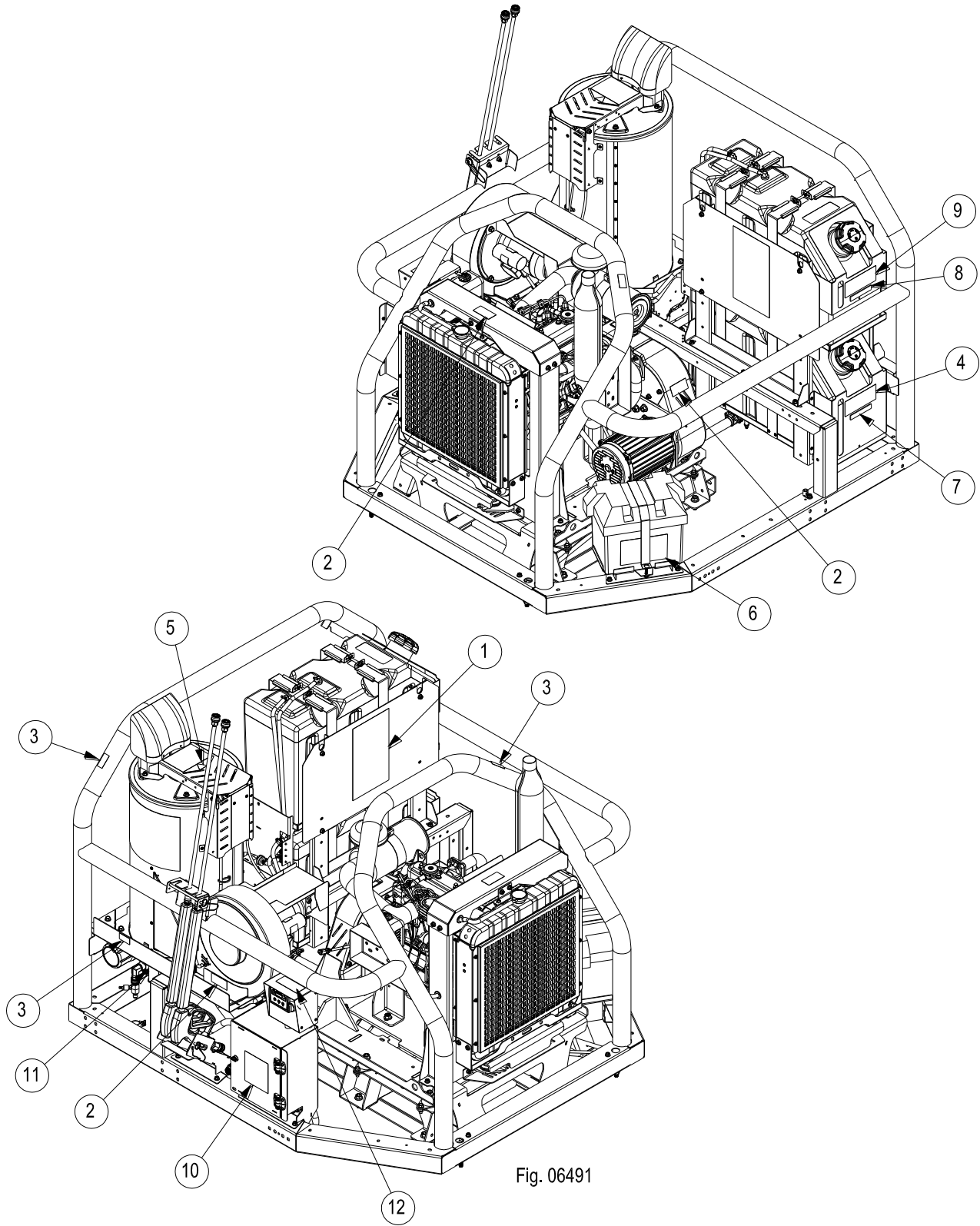
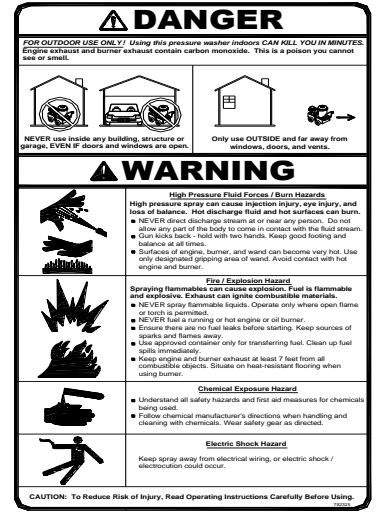

Fig. 06491

Safety Labeling

ON-PRODUCT WARNING LABELS			
Ref. #	Part #	Description	Qty.
1	782325	Decal, Danger and Warning	1
2	786632	Decal, Rotating Equipment Warning	3
3	797513	Decal, Burn Hazard	3
4	787827	Decal, Diesel Only	1
5	796496	Decal, ISO Electric Shock Warning Triangle	1
6	782397	Decal, Battery Warning	1
7	796862	Decal, Engine Fuel Tank	1
8	796861	Decal, Burner Fuel Tank	1
9	787827	Decal, Diesel, Kerosene or Fuel Oil Only	1
10	797448	Decal, Control Box, Operating Instructions	1
11	798057	Hantag, Rupture Disc Warning	1
11.1	32821	Lanyard, Hangtag Warning (not shown)	1
12	799556	Decal, Warning Prop 65	1

1



12

WARNING: Breathing diesel engine exhaust exposes you to chemicals known to the State of California to cause cancer and birth defects or other reproductive harm.

- Always start and operate the engine in a well-ventilated area.
- If in an enclosed area, vent the exhaust to the outside.
- Do not modify or tamper with the exhaust system.
- Do not idle the engine except as necessary.

For more information go to www.P65warnings.ca.gov/diesel.

7



8



9



10

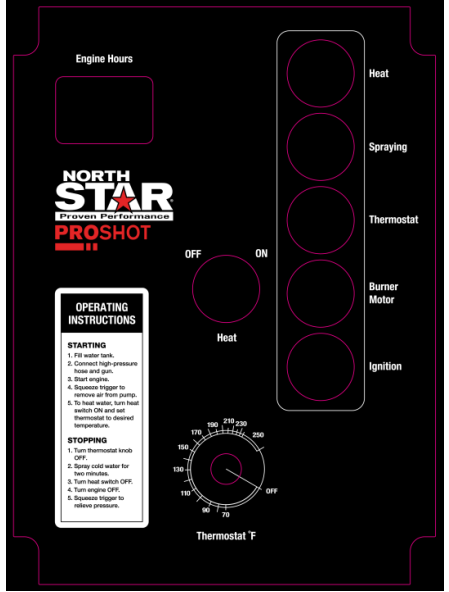

2



11



3



4



5

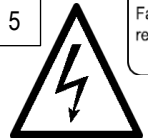

6

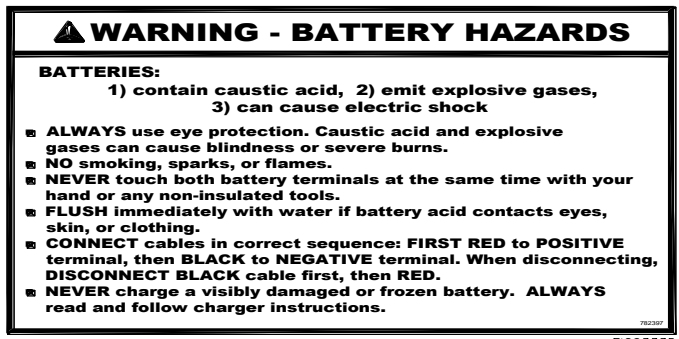

Always make sure safety labels are in place and in good condition. If a safety label is missing or not legible, order new labels or unsafe operation could result. To order replacement safety labels, call NorthStar ProSHOT Product Support at 1-800-969-7073.

Special Equipment Safety Features

<p>High Pressure Safety Device (Rupture Disc)</p>	<p>⚠ WARNING: If the high-pressure safety device ever discharges water, turn the engine off and do not use the machine. The device will no longer function properly. See a dealer or call Product Support at 1-800-969-7073.</p> <p>This unit is equipped with a high-pressure safety device, which acts as a safety feature. If the unloader malfunctions, the high-pressure safety device will open and relieve excess system pressure.</p>
<p>Temperature Sensor (Thermistor)</p>	<p>This unit is equipped with a temperature sensor that measures discharge spray temperature and automatically turns the burner off when the temperature setting is reached or is at maximum preset limit. When the discharge spray temperature drops, the burner automatically reignites.</p>
<p>Spray Gun Safety Latch</p>	<p>The spray gun is equipped with a built-in trigger safety latch to guard against accidental trigger actuation.</p>
<p>High Pressure Limit Switch</p>	<p>This unit is equipped with a high pressure limit switch, which acts as a primary safety feature. If the system pressure exceeds the set pressure limit this device will stop the burner from firing.</p>

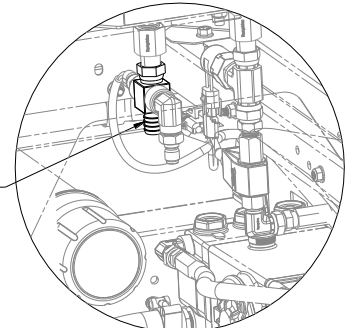

Fig.06625

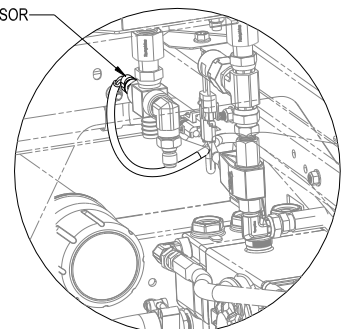

Fig.06067

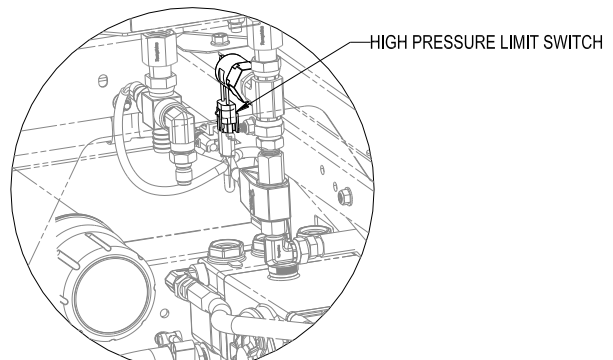
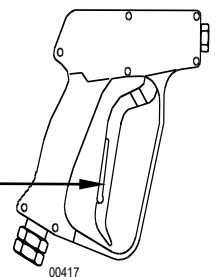

Fig.06624

Assembly & Initial Set-Up Instructions

STEPS FOR ASSEMBLY / INITIAL SET-UP

- Unpacking & Delivery Inspection
- Attaching a Water Feed Tank (customer supplied)
- Connecting Battery
- Initial Pump & Engine Preparation

Each of these steps will be discussed in detail below:

STEP 1. UNPACKING & DELIVERY INSPECTION

Find and separate the components identified in Fig. 06251 and Fig.06546 – Hardware Bag. Inspect the pressure washer immediately after you receive delivery for missing parts and damage.

If you have missing or damaged components, contact Product Support at 1-800-969-7073.

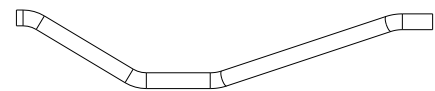
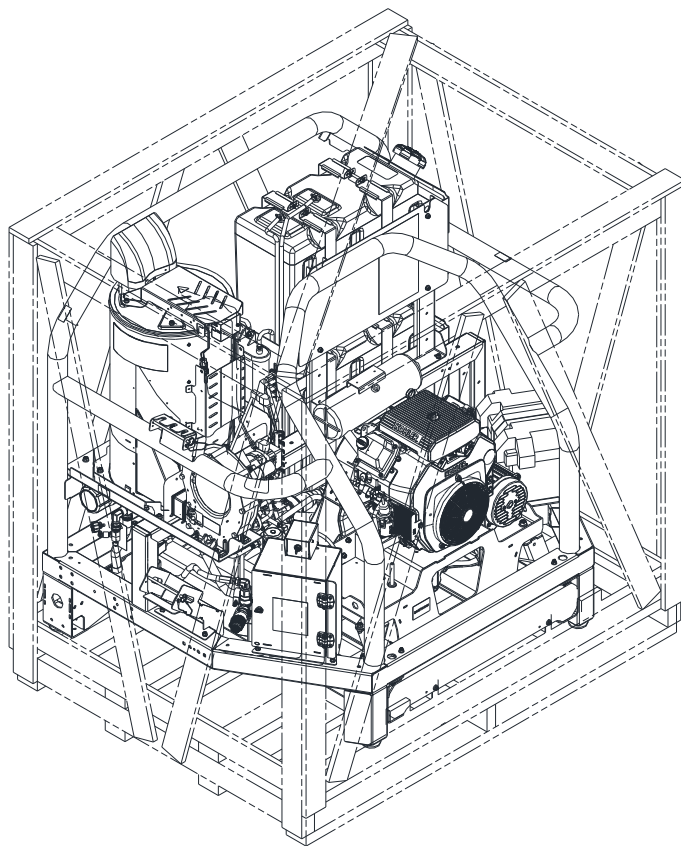

4' of 1" Suction Hose
Part #798209

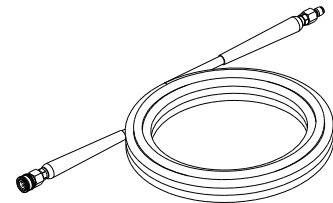

3/8" x 50'
High Pressure Hose
Part # 797590
Qty (2)

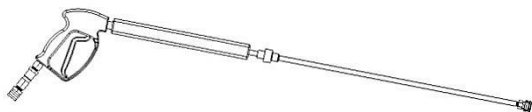

Pressure Washer Spray Gun – Qty. 2
Spray Gun – Part #796731
Lance – Part #791279
(Located strapped to the back of the Roll Cage)



Hardware Bag
(Located inside the small cardboard box on top of the battery compartment)

Assembly & Initial Set-Up Instructions

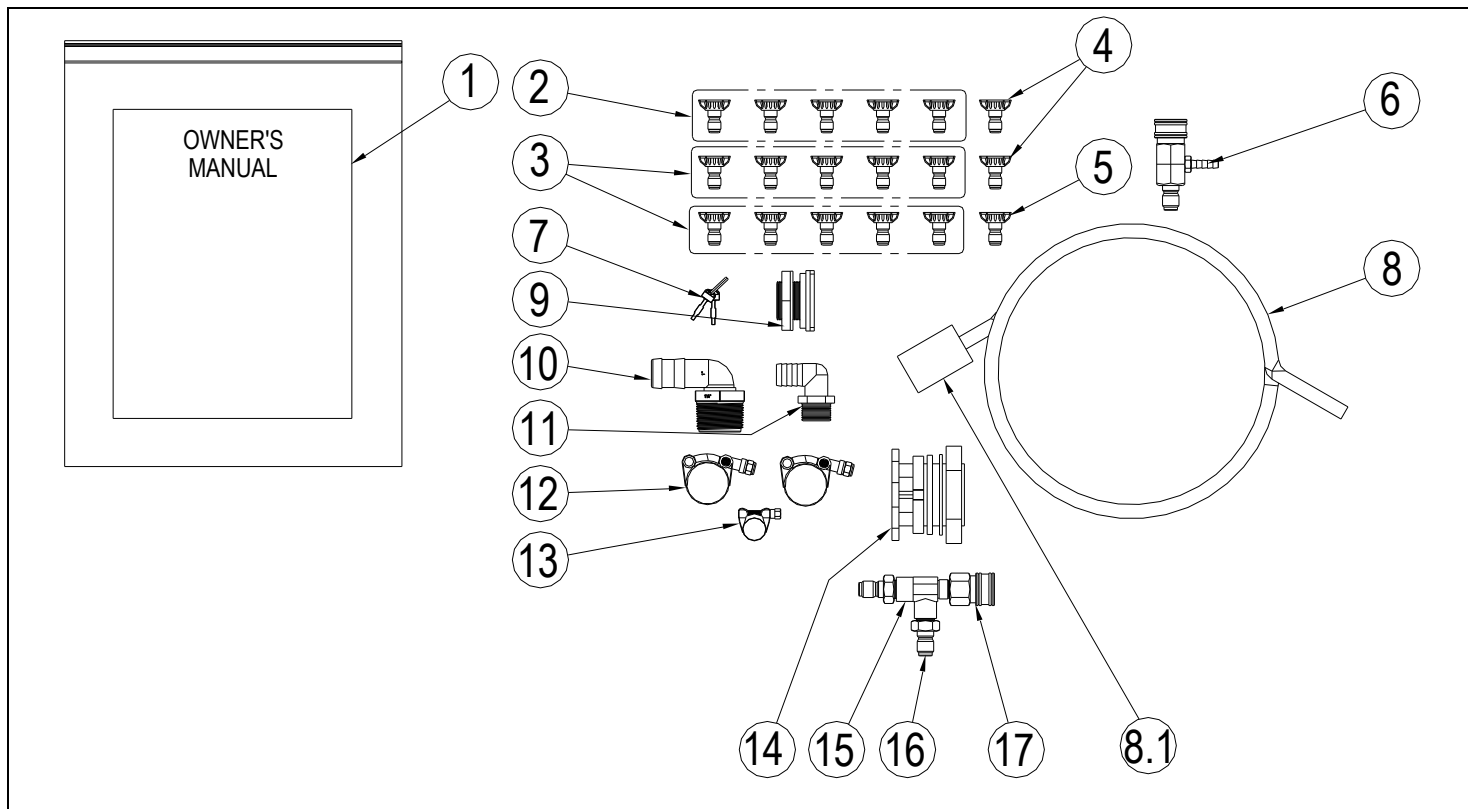

HARDWARE BAG CONTENTS

Ref. #	Part #	DESCRIPTION	QTY.
1	N/A	Manual, 157570	1
2	796627	Nozzle, 5 Pack #9.0	1
3	796216	Nozzle, 5 Pack #4.5	2
4	799396	Nozzle, #3.0 Yellow, (Steam)	2
5	799395	Nozzle, #7.0 Yellow, (Steam)	1
6	N/A	Chemical Injector, 2.3 high draw assembly	1
6.1	799571	Chemical Injector, 2.3, 3/8" high draw	1
6.2	777914	Coupling, QC 3/8" FNPT	1
6.3	777915	Nipple, QC 3/8" x 3/8" FNPT	1
7	KU005116	Kubota Engine Keys	1
8	777165	Chemical Hose	6 FT
8.1	221222	Chemical Strainer	1
9	5370	Fitting, 3/4 FPT Bulkhead	1
10	796842	Fitting, 1-1/4" MPT x 1" HB Elbow	1
11	50NBR12	Fitting, 3/4" x 3/4" HB Elbow	1
12	796619	T-Bolt Clamp, 1.34" – 1.46" OD	2
13	796618	T-Bolt Clamp, 1.06" – 1.14" OD	1
14	796841	Anti-Vortex Fitting, 1-1/4" x 1" HB Elbow	1
15	777347	Tee, Forged 6MP-6FP-6FP	1
16	777913	Nipple, QC 3/8" NPT Male	2
17	777914	Coupling, QC 3/8" NPT Female	1

Assembly & Initial Set-Up Instructions

STEP 2. ATTACHING A WATER FEED TANK (CUSTOMER SUPPLIED)

It is recommended that the water supplied to the pressure washer is by an external water tank. To connect an external water feed tank, follow the steps below:

CAUTION: Inadequate plumbing between a feed tank and the pressure washer can cause damage to the pump from water cavitation. To avoid water cavitation:

- Use 1" hose and fittings or larger (provided). Supply Line Hose should be no longer than 6'.
- Place feed tank so bottom of tank is level to the pump inlet.
- Place the feed tank as close as possible to the pressure washer so the supply line hose will be as short as possible.
- Make sure the supply line hose does not kink.
- Never allow tank to run dry.

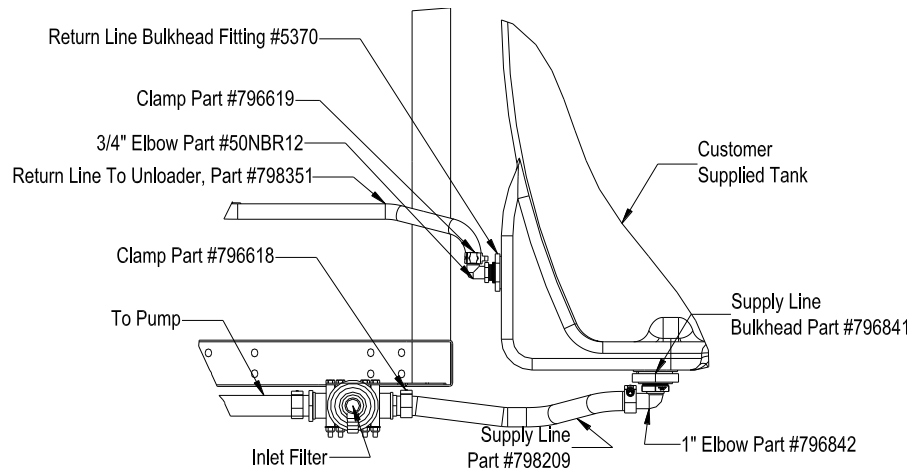

Figure 1

- Step 1.** Supply a 200-gallon or larger water feed tank. (The supply line hose and necessary fittings have been provided with this pressure washer.)
- Step 2.** Drill 2.25" diameter hole in the bottom of the tank for the supply line – this is the supply port. Drill a second 1.5" diameter hole a minimum of 1 foot away from the first hole for the return line – this is the return port. Both holes need to be drilled on flat surfaces of the tank.
- Step 3.** Insert supplied bulkhead fitting into each hole.
- Step 4.** Thread the supplied 1" elbow fitting into the supply line bulkhead fitting. Thread the supplied 3/4" hose barb fitting into the return line bulkhead fitting.
- Step 5.** Make sure the bottom of the water tank is level with the pump inlet on the skid frame.
- Step 6.** Connect the supply line (1" supply line hose provided, Figure 1):
 - a. Connect to the 1" elbow fitting in the supply port on the water tank. Use the t-bolt hose clamp that has been provided.
 - b. Connect the other end to the water inlet on the inlet filter (see Component Identification section of this manual). Use the t-bolt hose clamp that has been provided. Make sure the connection hose does not kink.
- Step 7.** Connect the return line (connected to the unloader on the skid, Figure 1):
 - a. Connect to the 3/4" elbow onto the return line bulkhead fitting on the water tank.
 - b. Connect the return line to the 3/4" elbow and use the t-bolt hose clamp that has been provided.

CAUTION: To protect the pump, do not add cleaning chemicals directly to the tank water. Use the quick coupler chemical injector provided. Then follow all instructions and precautions for chemical spraying.

See "Operating the Pressure Washer, Step 2. Set Up for Chemical Spray" section in this manual.

Assembly & Initial Set-Up Instructions

STEP 3. INITIAL PUMP & ENGINE PREPARATION

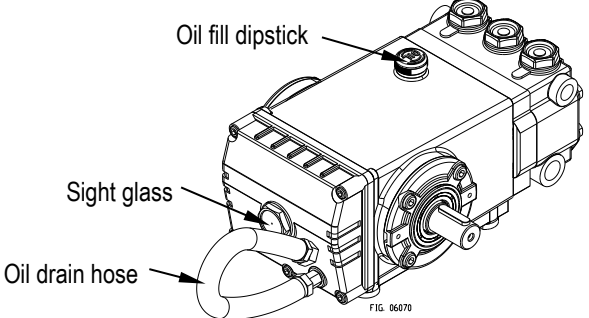
<p>Prepare Water Pump</p>	<p>Verify pump oil level.</p> <p>NOTICE: The pump is shipped <u>with</u> oil.</p> <ol style="list-style-type: none"> 1. Verify that oil level is half way up the sight glass (or at the indicator line on the dip stick). 2. If oil level is low, fill with SAE Non-detergent 30wt. oil. 3. Replace oil fill dipstick. 	 <p>Oil fill dipstick</p> <p>Sight glass</p> <p>Oil drain hose</p> <p>FIG. 06070</p>
----------------------------------	---	--

<p>Check Engine Oil</p>	<p>Check the engine oil before starting the pressure washer.</p> <p>NOTICE: The engine is shipped with oil. You must check oil before use. Refer to the engine manual to locate oil-fill port and for instructions on filling. Use the oil grade and quantity specified in the engine manual.</p>
--------------------------------	---

STEP 4. CONNECTING THE BATTERY

Unit is supplied with a battery, but not connected for shipping. The engine will not run unless a battery is connected.

Follow the steps below for connecting and disconnecting the battery.

If replacing the existing battery, a 12-volt standard, top-post mount, automotive battery (Group 75/86) with a minimum 24 amp-hour rating should be used. The battery should be installed in the protective battery box located near the engine. The inside dimensions of the battery compartment are 11-1/8" L x 7-3/4" W x 10-1/8" H.



⚠ WARNING: Batteries are hazardous because they contain caustic acid, can emit explosive gases, and can cause electric shock. Caution must be exercised when making connections to a battery to avoid shock and contact with the acid, and to prevent any sparking that could lead to an explosion. ALWAYS follow the general battery safety rules and instructions listed below.

<p>General Battery Safety Rules</p>	<ul style="list-style-type: none"> • ALWAYS use eye protection and protective clothing when handling batteries. • NEVER smoke or work near sparks or other sources of ignition. • NEVER touch both battery terminals at the same time with your hand or any other non-insulated tools. • If battery acid contacts skin or clothing, flush immediately with water and neutralize with baking soda.
<p>Connecting the Battery</p>	<p>Always connect the cables in the following sequence to avoid possible shock:</p> <ol style="list-style-type: none"> 1) Find the battery cables located inside the battery compartment. 2) Connect the red cable to the positive (+) terminal of the battery. 3) Then connect the black cable to the negative (-) terminal of the battery.
<p>Disconnecting the Battery</p>	<p>Always disconnect cables in the following sequence to avoid possible shock:</p> <ol style="list-style-type: none"> 1) First, disconnect the black cable from the negative (-) terminal of the battery. 2) Next, disconnect the red cable from the positive (+) terminal of the battery. 3) Remove the battery from the battery compartment.
<p>Grounding Skid to Trailer</p>	<p>⚠ WARNING: Always ensure the pressure washer is properly grounded to trailer frame to prevent electrical shock and static electricity.</p> <p>Shipping pallets can insulate the pressure washer from the trailer frame. Always ensure grounding wire is connected to bare metal on the trailer frame as shown in Figure 06603.</p>

Assembly & Initial Set-Up Instructions

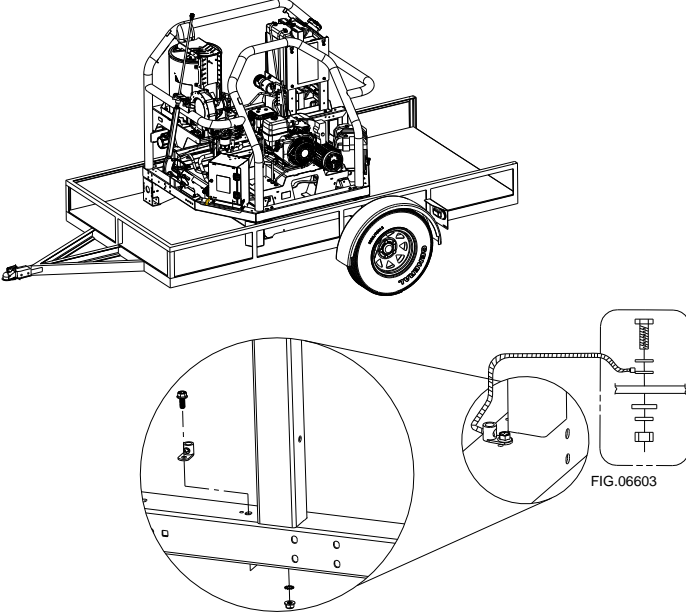
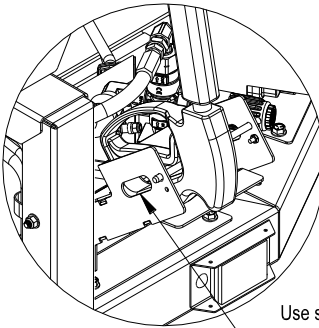
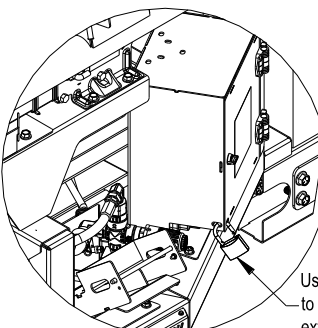
	<p>You must always ground the pressure washer as directed below when using or fueling the pressure washer on a trailer.</p> <p>Using a 10 AWG or larger copper grounding cable, connect one end of the grounding cable to the grounding terminal on the skid frame (see Figure 06603), and connect the other end of the grounding cable to bare metal on the trailer frame (see figure 06603). See detail below for replacement part numbers.</p> <ol style="list-style-type: none"> 1. Grounding Terminal located on skid frame. 2. 10 AWG or larger insulated copper Grounding cable (not supplied) 3. Always mount to the metal of the truck or trailer frame. <div style="text-align: right;">  <p>FIG.06603</p> </div>
<p>Anti-Theft Features</p>	<p>This skid is designed for easy use of cable locks and/or padlocks to secure your items.</p> <ul style="list-style-type: none"> • Lockable control box/nozzle holder. Slots were added for the use of a padlock. • Lockable spray gun mount. Slots were added for the use of a cable lock and or a padlock. <div style="display: flex; justify-content: space-around;"> <div style="text-align: center;">  <p>FIG.06311</p> <p>Use slots provided to add a cable lock & padlock for extra security.</p> </div> <div style="text-align: center;">  <p>Use slot provided to add a padlock for extra security.</p> </div> </div>

Moving the Pressure Washer

⚠ WARNING

The pressure washer is heavy. You can be injured when trying to lift it without mechanical assistance. It can crush and cause serious injury if it drops on someone. Follow the instructions below for safely moving the pressure washer.

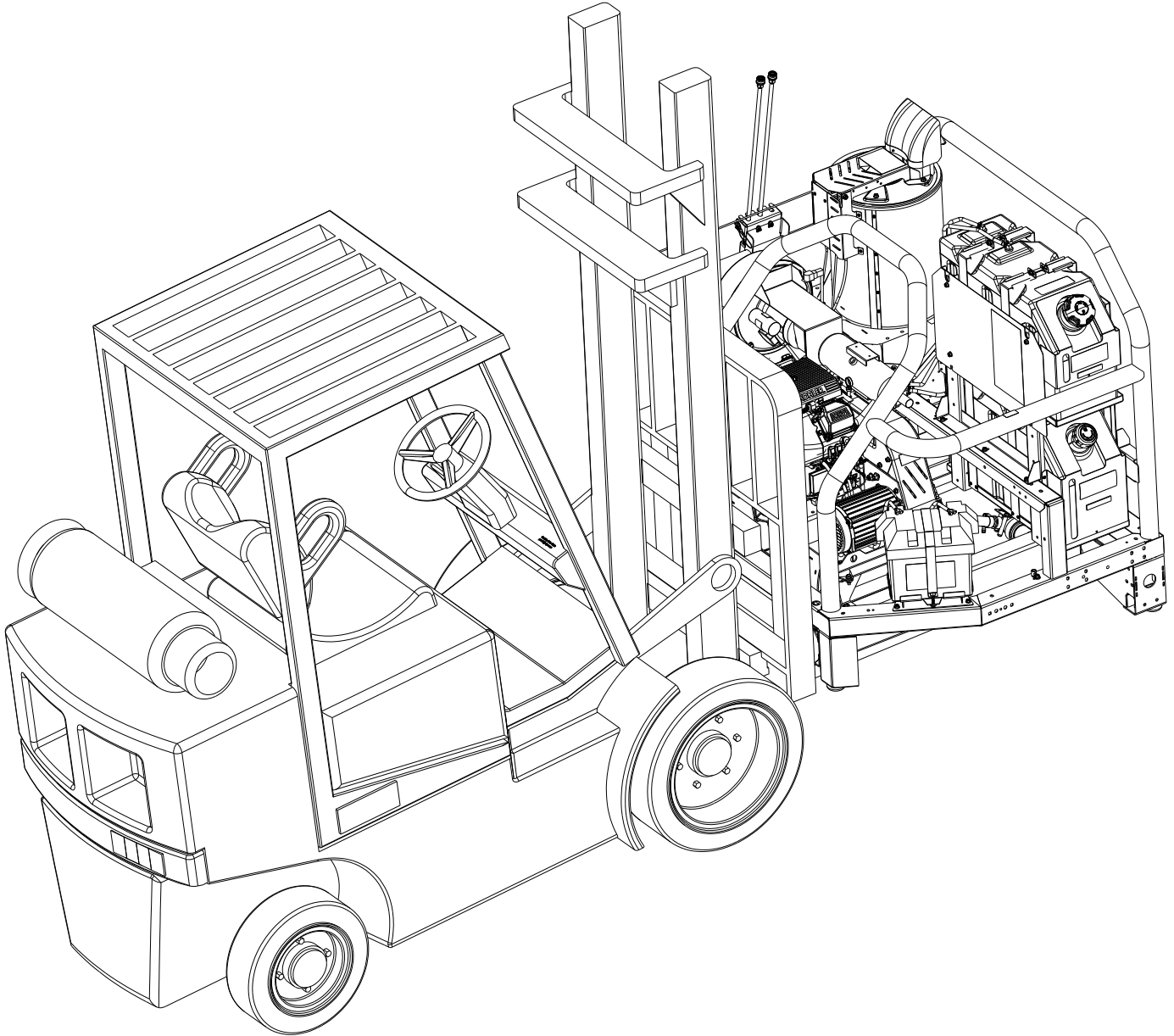

Align the forks with the frame rails under the pressure washer skid. Lift the skid with engine facing the forklift. You will need to tip forks up to keep skid from rolling forward off the forks.

Before Each Use

Follow the steps below prior to each use of the pressure washer.

STEPS TO FOLLOW BEFORE EACH USE

• Check Equipment

• Add fuel (s)

• Select a Suitable Worksite

STEP 1. CHECK EQUIPMENT

<p>Check/Add Pump Oil</p>	<p>Check/add pump oil.</p> <p>CAUTION: Never run the pump without enough lubrication!</p> <ol style="list-style-type: none"> 1) Check oil level. Verify that oil level is half way up the sight glass (or at the indicator line on the oil fill dipstick). 2) If oil level is low, fill using SAE Non-detergent 30wt. oil. 3) Replace oil fill dipstick.
<p>Check/Add Engine Oil</p>	<p>Check the engine oil level and add oil as needed.</p> <p>Use the recommended oil type for your engine and expected ambient conditions. (See engine owner's manual for oil type and capacity, and more detailed oil check/fill instructions.)</p> <p>▲ WARNING: Burn hazard</p> <p>Never open oil port while engine is running. Hot oil can spray over face and body.</p> <p>NOTICE:</p> <ul style="list-style-type: none"> • Low oil shutdown feature prevents the engine from starting without enough oil. • Engine is shipped <u>with</u> oil. You must check oil before first use.
<p>Inspect Spray System</p>	<p>Always inspect spray system for damage and leaks before each use.</p> <p><u>DO NOT START PRESSURE WASHER UNTIL ALL NEEDED REPAIRS HAVE BEEN COMPLETED.</u></p> <p>▲ WARNING: High pressure fluid injection hazard</p> <p>High-pressure fluid discharge from leaks (even pin-sized) or ruptured components can pierce skin and inject fluid into the body. Injection injury can result in blood poisoning and/or severe tissue damage leading to infection, gangrene, and possibly loss of limb.</p> <ul style="list-style-type: none"> • Never use a finger or skin to check for leaks. • Never operate machine with damaged or missing hoses/parts. • Never attempt to repair a high-pressure hose or component – Always replace it with a part that is rated at or above the pressure rating of this machine. <ol style="list-style-type: none"> 1) Check hoses, fittings, wand, trigger gun, and connections for signs of wear, cracks, looseness, or leaks. Replace as required. 2) Check and clean the nozzle orifice. 3) Clean inlet filter (see Maintenance & Repair).
<p>Inspect Fuel System</p>	<p>Always inspect (engine and burner) fuel systems & check for leaks BEFORE starting pressure washer.</p> <p><u>DO NOT START PRESSURE WASHER UNTIL ALL NEEDED REPAIRS HAVE BEEN COMPLETED.</u></p> <p>▲ WARNING: Fuel leak hazard</p> <p>Diesel and burner fuels are highly explosive and fuel leaks can result in fire or explosions. You can be burned and seriously injured if the fuel system is not properly hooked up or there is a fuel leak when you start the engine.</p> <p>Inspect the entire fuel system. Look for:</p> <ul style="list-style-type: none"> • signs of leaks or deterioration • chafed or spongy fuel hose • loose connections • loose or missing fuel hose clamps • damaged diesel tank, or a defective diesel shut-off valve

Before Each Use

Clean Inlet Filter	Clean the water inlet filter before each use. For instructions see section Maintenance & Repair.
Perform Other Scheduled Maintenances as Needed	<p>Make sure that any other regular maintenance has been performed as prescribed in this manual in the "Maintenance & Repair" section.</p> <ol style="list-style-type: none"> 1) Refer to the engine's owner's manual for engine maintenance instructions. 2) Make sure battery is charged. Charge as needed according to your battery manufacturer's instructions.

STEP 2. ADD FUEL(S)

⚠ WARNING: Fuel fire/explosion hazard

Burner fuels are combustible at warm temperatures. Heat, sparks, and flames can ignite fuel vapors, which can become widespread during fueling. A flash fire and/or explosion could result and cause serious injury or death. Always use extreme care when handling fuels. Carefully follow all instructions to avoid the following conditions which could result in fuel ignition:

- diesel vapor collection inside enclosures
- static electric sparks
- sparks from electric wiring, batteries, or running engines
- sources of heat (such as a hot engine, burner, or exhaust)
- open flames, including pilot lights

Always follow these general safety rules when fueling:

- 1) Turn pressure washer off and allow to cool for at least two minutes before removing any fuel cap.

Note: A running, or still-hot engine or burner is hot enough to ignite fuel.

- 2) Fill fuel tanks OUTDOORS – never indoors. Fuel vapors can ignite if they collect inside and enclosure and explosion can result.
- 3) Stay away from all sources of heat, sparks, and flames. Do not smoke.
- 4) Never pump fuel directly into the fuel tank or burner tank at a gas station – it could cause a static electric spark.

Follow these steps to avoid static electric sparking during fueling:

- Use an approved portable container to transfer fuel to the pressure washer's tank. (A portable container made of metal or conductive plastic is preferred because it dissipates charge to ground more readily.)
- Always place container on the ground to be filled. Never fill the portable gas container while it is sitting inside a vehicle, trailer, trunk, or pick-up truck bed.
- Dissipate static charge from your body before beginning the fueling process by touching a grounded metal object at a safe distance from fuel sources.
- Keep nozzle in contact with container while filling. Do not use a nozzle lock-open device.

Clean up fuel spills /splashes immediately.

- If possible, move the pressure washer away from spilled fuel on the ground.
- Wipe up spilled fuel and wait 5 minutes for excess fuel to evaporate before starting engine.
- Fuel soaked rags are flammable and should be disposed of properly.

If fuel is spilled on your skin or clothes, change clothes and wash skin immediately.

Fill Engine fuel tank	<p>Check the fuel tank level. If needed, fill tank with fresh #1 or #2 diesel, from a portable container:</p> <ol style="list-style-type: none"> 1) Remove fuel cap. 2) Add fuel through the fill opening: <ul style="list-style-type: none"> - Use only a UL-approved portable container to transfer the fuel to engine's tank. - Add fuel through the fill opening. Do not overfill. Allow at least 1/2" of empty space below fill neck to allow for fuel expansion. 3) Replace fuel cap securely before starting engine. 4) Wipe any excess fuel from unit before starting.
------------------------------	--

Before Each Use

<p>Fill Burner Fuel Tank (if planning to use heated water)</p>	<p>If you are planning to use heated water, fill burner fuel tank with #1 or #2 diesel, B5 or lower biodiesel, kerosene, or fuel oil.</p> <ol style="list-style-type: none"> 1) Remove fuel cap. 2) Add fuel through the fill opening. Do not overfill. Allow at least 1/2" of empty space below fill neck to allow for fuel expansion. 3) Replace fuel cap securely before starting engine. 4) Wipe any excess fuel from unit before starting.
--	---

STEP 3. SELECT A SUITABLE OUTDOOR WORKSITE

Before using the pressure washer, you must understand the criteria for selecting a suitable location for operation. Note that this pressure washer is for OUTDOOR USE only.

⚠ WARNING: You must choose a suitable site for operating your pressure washer to avoid equipment damage and/or injury and possible death from carbon monoxide poisoning, fire/explosion, uncontrolled equipment movement/tip over, or slips and falls. Choose a site that meets all the following six criteria:

- 1) OUTDOORS only, and away from all building windows and air intakes.
- 2) Where no flammable vapors, dusts, and gases are present.
- 3) Where there is adequate, unobstructed ventilation airflow.
- 4) With adequate clearance from combustible materials.
- 5) On a firm, level, heat-resistant surface with good drainage.
- 6) If placed inside a truck bed, or on a trailer ensure skid is secured and properly grounded. To properly ground the skid, see the Assembly & Initial Set-Up instructions.

Details regarding each of these criteria are provided below.

<p>Outdoor Use Only</p>	<p>⚠ DANGER: Carbon monoxide poisoning hazard</p> <p>Exhaust fumes from both the engine and the burner contain carbon monoxide (CO), a poisonous gas you cannot see, smell, or taste. The CO generated by the pressure washer can rapidly accumulate, even in areas that appear to be well-ventilated, resulting in dangerous and fatal concentrations within minutes. Follow the directions below for choosing a location to operate your pressure washer to avoid carbon monoxide poisoning.</p> <p>The location you choose to operate the pressure washer must be OUTDOORS and away from all building air intakes.</p> <ul style="list-style-type: none"> • Never run the pressure washer in an enclosed or partially enclosed location such as a building, garage, barn, shed, or house. <i>These spaces can trap poisonous gases. Running a fan or opening windows will not provide adequate ventilation to prevent dangerous CO build-up.</i> • Only use the pressure washer outdoors and far away from open windows, doors, and building or vehicle vents. • Place the pressure washer so that the exhaust fumes will not be directed towards people or building air intakes. • Ensure that working, battery-operated or battery back-up carbon monoxide alarms are used in any dwelling/structure that is near the running pressure washer. • Note that this pressure washer is NOT designed or approved for use in vehicles or marine applications. Never run the pressure washer inside RVs or other vehicles, on boats, or on pick-up truck beds. <p>⚠ WARNING: Never attempt to attach ductwork to the engine muffler or burner exhaust to allow for installation inside an enclosure. This could cause hot air deflection, heat build-up, and increased exhaust back-pressure, resulting in possible exhaust leakage or overheating and damage to the pressure washer.</p>
-------------------------	---

Before Each Use

<p>Stay Away from Combustible Dust, Liquids or Vapors</p>	<p>Do not locate and use the pressure washer in the presence of flammable vapors, dust, gases, or other potentially combustible materials.</p> <p>The burner is an open flame, which can ignite airborne dusts and flammable vapors. Operate only where open flames and torches are permitted.</p>
<p>Be Sure to Have Adequate Airflow</p>	<p>The pressure washer needs adequate, unobstructed flow of air to allow for proper combustion and adequate cooling.</p> <p>Proper combustion can only be obtained when there is an enough supply of oxygen available for fuel being burned. Cooling ventilation is required to prevent overheating of the pressure washer and possible fire.</p> <ul style="list-style-type: none"> • Situate so there is adequate clearance around pressure washer to allow for airflow – at least 7 feet from any non-combustible wall or obstruction. • Never place any objects against or on top of the pressure washer. • Do not operate with a tarp, blanket, or cover surrounding the pressure washer.
<p>Have Clearance for Hot Exhaust</p>	<p>The exhaust gas from your pressure washer is extremely hot and can cause combustible materials to catch on fire.</p> <ul style="list-style-type: none"> • Make sure both the engine exhaust and burner exhaust are at least 7 feet from all combustible materials and buildings/structures during operation. • Equip the engine with a spark arrestor if the pressure washer will be used near any ignitable forest, brush, or grassy land. (See the engine manual provided with this equipment to determine if the engine is already equipped.) Make sure you comply with applicable local, state, and federal codes. • Keep a fire extinguisher rated "ABC" nearby. Keep it properly charged and be familiar with its use.
<p>Have a Firm, Level Heat-Resistant Surface</p>	<p>The pressure washer should be positioned on a firm, level (less than 3-degree slope), heat-resistant surface with good drainage.</p> <p>Ensure that the pressure washer sites level and will not slide or shift during operation. If applicable, block the pressure washer's wheel to prevent movement. Surface should be heat-resistant if you will be using the burner for heated spray.</p>

Operating the Pressure Washer

After you have checked and fueled the equipment and positioned it in a suitable worksite, it is time to start your pressure washer. The following are the procedures necessary for safe, successful operation of your pressure washer.

⚠ WARNING

Carefully read and follow all instructions and safety information for using this pressure washer. Improper use or maintenance of the pressure washer can result in *serious injury or death* to the operator or bystanders from:

- Carbon monoxide poisoning
- Skin/eye injury from high pressure spray
- Fire/explosion
- Burns
- Electric shock
- Chemical exposure
- Slips/falls
- Flying objects/debris

OPERATING INSTRUCTIONS

- | | |
|---|--|
| <ul style="list-style-type: none"> • Connect hoses, water supply, and spray nozzle • Spraying | <ul style="list-style-type: none"> • Set up for chemical spray (if desired) • Stopping |
|---|--|

Each of these procedures will be discussed in detail below.

STEP 1. CONNECT HOSES, WATER SUPPLY, AND SPRAY NOZZLE

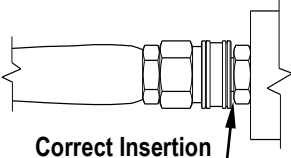
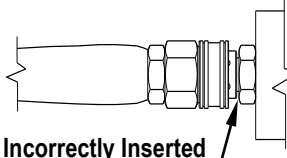
<p>Position Pressure Washer for Use</p>	<p>Place pressure washer in a suitable location for use, as directed in the Before Each Use, step 3: Select Suitable Outdoor Worksite section of this manual. A suitable location is:</p> <ul style="list-style-type: none"> • OUTDOORS only, away from all building air intakes. • Where no flammable vapors, dusts, and gases are present. • Where there is adequate, unobstructed ventilation airflow. • With adequate clearance from combustible materials. • On a firm, level, heat-resistant surface with good drainage. <p>⚠ DANGER: Carbon monoxide poisoning hazard. Exhaust fumes from both the engine and the burner contain carbon monoxide (CO), a poisonous gas you cannot see, smell, or taste. The CO generated by the pressure washer can rapidly accumulate, even in areas that appear to be well-ventilated, resulting in dangerous and fatal concentrations within minutes. ONLY run pressure washer OUTDOORS and at least 20 feet from the home, away from windows, vents and air intakes, to allow proper ventilation. If you start to feel sick, dizzy, or weak while using the pressure washer, shut off the engine and get to fresh air RIGHT AWAY. NEVER run pressure washer inside any enclosed or semi-enclosed spaces, including homes, garages, basements, sheds, boxes, pick-up truck beds, RVs, or boats. These spaces can trap poisonous gases, EVEN if you run a fan or open windows.</p>
<p>Attach Gun to the High-Pressure Hose</p>	<p>Attach the high-pressure hose to the pressure washer's water outlet.</p> <p>⚠ WARNING: NEVER operate this pump with components (such as hose, connections, and spray gun) rated for lower pressure and/or temperature limits than the machine's maximum rated pressure and temperature, or component could rupture and cause serious personal injury from escaping high pressure fluids.</p> <ol style="list-style-type: none"> 1) See "Component Identification" section of this manual for location of the pressure washer's water outlet. 2) Your pressure washer hose is equipped with quick couplers. Simply pull the collar back and push the coupler onto the water outlet nipple (Figure 2a). <p>The collar should slide over the ball bearings.</p> <div style="display: flex; justify-content: space-around; align-items: flex-end;"> <div style="text-align: center;">  <p>Correct Insertion Collar Seated</p> </div> <div style="text-align: center;">  <p>Incorrectly Inserted Collar NOT Seated</p> </div> </div> <p>Figure 2a</p>

Operating the Pressure Washer

- 3) Release the collar, making sure it springs back and re-seats to its original (non-retracted) position (Figure 2b). Check the connection by pulling on the hose to ensure a positive connection.

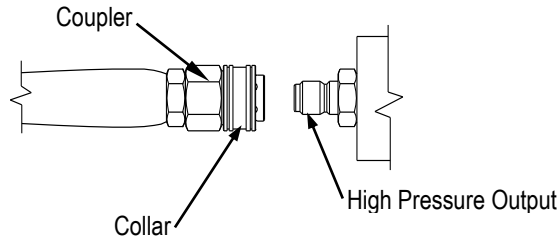

Figure 2b

Select the Spray Nozzle

Your pressure washer is equipped with 15 high-pressure nozzles and 3 low-pressure nozzles. (1 #7.0 Steam and 2 #3.0 Steam nozzles). Generally, the wider the spray angle of the nozzle, the lower the spray pressure produced. Select nozzles based on the type of job you are doing (color of nozzle) and whether you are using two guns or one (size of nozzle).

1. One gun vs. two-gun use:

- Use a #9.0 nozzle for single gun operation. This will ensure the rated flow and psi are achieved.
- Use two #4.5 nozzles when operating dual guns.
- Use a #7.0 yellow steam nozzle for single gun operation.
- Use two #3.0 yellow steam nozzles when operating dual guns.

⚠ WARNING: NEVER use #9.0 nozzles when operating both guns. If two operators use #9.0 nozzles and one operator releases the trigger on their gun, the flow through the second operator's gun will suddenly increase from 4.5 to 8 GPM. This will cause the second operator's gun to kick without warning, which could result in loss of balance and/or spraying control.

2. Type of cleaning job:

Select the appropriate color nozzle for the job based on the following table. Generally, the wider the spray angle of the nozzle, the lower the spray pressure produced.

COLOR OF NOZZLE	SIZE			SPRAY ANGLE	USED FOR
	1 GUN USE	2 GUN USE			
RED	9.0	4.5	4.5	0	HIGHEST IMPACT
YELLOW	9.0	4.5	4.5	15	TOUGH STAINS/STRIPPING
GREEN	9.0	4.5	4.5	25	GENERAL
WHITE	9.0	4.5	4.5	40	LIGHT CLEANING
BLACK-LOW PRESSURE	40.0	40.0	40.0	65	CHEMICALS
YELLOW	7.0	3.0	3.0	15	STEAM

NOTE:

You must use the low-pressure black nozzle for spraying chemicals. For dual gun use with chemicals, you will need a black, #40.0 nozzle on each gun – you will not be able to spray chemicals out of one gun and plain water out of the other gun at the same time.

Attach the Nozzle

Attach nozzle to the spray gun.

⚠ WARNING: DEPRESSURIZE FIRST

Any time you remove/install/change a nozzle, you must depressurize hose line by squeezing the spray gun trigger while the engine is off. Even if the engine has been off for a long period of time, the hose may remain dangerously pressurized.

Operating the Pressure Washer

- 1) Make sure the engine is off and the hose line depressurized.
- 2) To install the nozzle, pull the collar back and twist the nozzle firmly into the coupler on the end of the wand (Figure 3a).

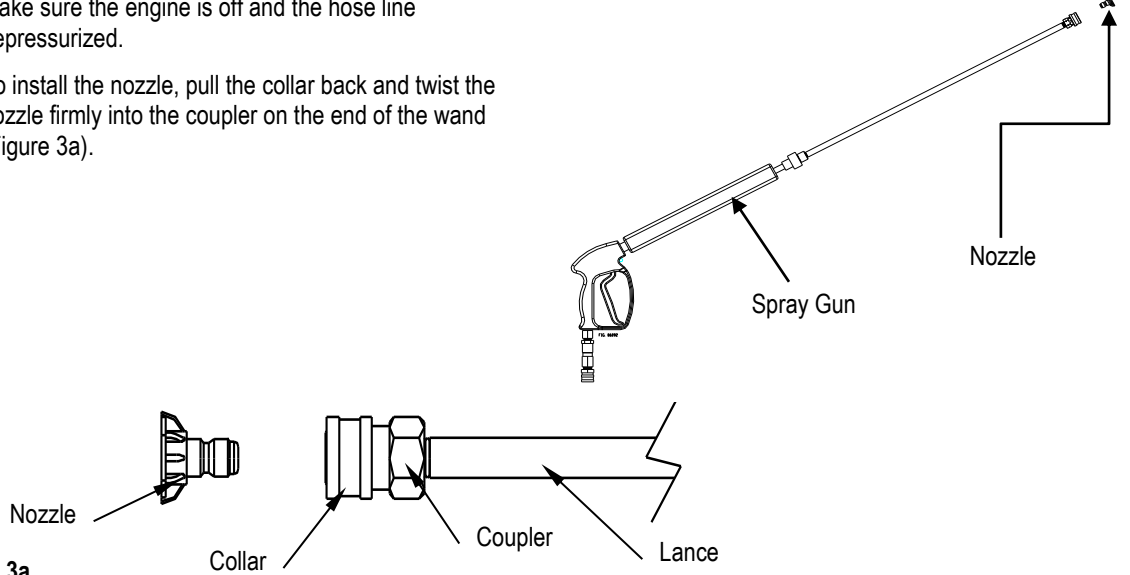

Figure 3a

- 3) Release the collar, making sure it springs back and re-seats to its original (non-retracted) position (Figure 3b). Check the connection by pulling on the nozzle to ensure a tight connection -- if correctly inserted, nozzle will rotate but not pull out.

⚠ WARNING: Make sure the nozzle is correctly inserted. Sprayer nozzle can become a projectile and cause serious personal injury or property damage if not properly connected to the spray gun. Do not attempt to use different types of nozzles that may not fit the coupler.

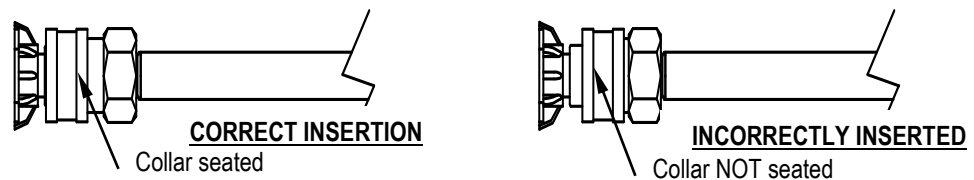

Figure 3b

STEP 2. SET UP FOR CHEMICAL SPRAY (IF DESIRED)

Using the proper cleaning chemical for the application can speed up cleaning jobs tremendously.

Your pressure washer is equipped with a chemical tank and chemical injector, which siphons cleaning chemicals into a low-pressure washer spray downstream of the pump. Adequate suction pressure is created *only when the low pressure (black) spray nozzle* is used.

The introduction of cleaning chemicals via the chemical injector affords the following advantages:

- It protects the pump from damage because no chemical passes through the pump.

CAUTION: Certain chemicals, such as bleach or those containing muriatic acid, will cause pump damage if introduced upstream through the pump's water inlet.

- It mixes the cleaning chemical into a low-pressure spray. Cleaning chemicals applied under low pressure adhere better to the surface being cleaned, allowing the formula time to react and remove dirt more effectively.

NOTICE: An external chemical injector pump is not recommended for use with this pressure washer.

⚠ WARNING: Chemical Spraying

- Never spray acids, corrosives, or abrasive or flammable liquids. Breathing hazards, surface burns/corrosion, or fire/explosion could result.

Operating the Pressure Washer

Follow the chemical manufacturer's label instructions for proper use and handling of the chemical. Understand all safety hazards and first aid for all chemicals being used. Always wear protective gloves when handling and cleaning with chemicals, and wear other protective gear as directed by chemical manufacturer. Always dispose of hazardous fluids per local, state, and national guidelines.

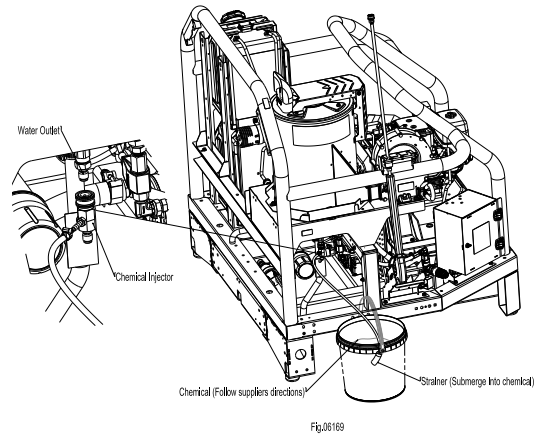

<p>Acquire Cleaning Chemicals</p>	<p>Use only NorthStar pressure washer chemicals or chemicals specifically formulated for use with pressure washers.</p> <p>CAUTION: Non-approved chemicals can damage pressure washer components (seals, wand, hoses, pump, etc.) and be harmful to the environment. It could also void the warranty.</p>
<p>Prepare for Chemical Spray (If you plan to use)</p>	<p>Prepare the pressure washer for chemical spraying using the following steps:</p> <ol style="list-style-type: none"> 1) Prepare the chemical cleaning solution as recommended by the chemical label required for the job. <p>NOTICE: The chemical injector is fixed and will mix the chemical solution into the spray at a dilution of 18:1.</p> <ol style="list-style-type: none"> 2) Disconnect the high-pressure hose from the water outlet. 3) Snap the quick couple chemical injector onto the water outlet, then snap the high-pressure hose onto the chemical injector. 4) Submerge the suction strainer connected to the braided chemical hose into a bucket containing the chemical solution.



STEP 3. SPRAYING

<p>Safety Rules for Operation</p>	<p>Before starting the pressure washer, review the following general safety rules for operation:</p> <p style="text-align: center;"><u>CONDITIONS FOR USE</u></p> <p><u>Know how to stop.</u> Be thoroughly familiar with proper use of the equipment and all controls and connections. Know how to stop the pressure washer and depressurize system quickly if needed (see Step 4. Stopping).</p> <p><u>Instruct all operators.</u> The pressure washer's owner must instruct all operators and potential renters in safe set-up and operation. Do not allow anyone to operate the pressure washer who has not read the owner's manual and been instructed on its safe use.</p> <p><u>Adult control only.</u> Only trained adults should set up and operate the pressure washer. Do not let children operate. Pressure washers can generate forces greater-than children can control and require judgment beyond what can be expected of children.</p> <p><u>Under the influence.</u> Never operate, or let anyone else operate, the pressure washer while fatigued or under the influence of alcohol, drugs, or medication.</p> <p><u>Safety equipment / controls in place.</u> Do not operate the pressure washer unless all safety covers, guards, and barriers are in place and in good working order, and all controls are properly adjusted for safe operation.</p> <p><u>Damaged.</u> Do not operate the pressure washer with damaged, missing, or broken parts. Never attempt to repair a high-pressure hose or component. Always replace it with a part that is rated at or above the pressure rating of the machine.</p> <p><u>Modifications.</u> Do not modify the pressure washer in any way or deactivate any safety device. Do not change or add to fuel tank, fuel lines, or exhaust system. Modifications can result in hazards related to carbon monoxide poisoning, fuel leaks, fire, explosion, or other serious safety hazards, and will also void the warranty.</p> <p style="text-align: center;"><u>DURING USE</u></p> <p><u>Stay alert.</u> Always watch what you are always doing.</p> <p><u>Clear work area.</u> Clear the work area of all bystanders. Keep children and pets away.</p>
--	---

Operating the Pressure Washer

	<p><u>Dual gun use (if equipped).</u> During dual gun use, always stay aware of the other operator's location and keep spray directed away from them.</p> <p><u>Keep spray away from electrical wiring.</u> Spray contact with electrical wiring will likely result in severe electrical shock or electrocution.</p> <p><u>Hot exhaust/parts.</u> Stay clear of the engine and burner exhausts. Never touch a hot engine muffler, burner/heating coil, or other hot surfaces. All are extremely hot and will burn you.</p> <p><u>Do not direct spray at this machine.</u> Do not attempt to clean this machine with its own spray. Engine damage will result. Cleaning should be done with a damp sponge with the engine OFF.</p> <p><u>Let engine cool.</u> At least two minutes before refueling.</p> <p><u>Avoid inhalation of exhaust.</u> This product emits CO and chemicals known to the State of California to cause cancer, birth defects, or other reproductive harm.</p> <p><u>Never pull by hose.</u> Do not move this machine by pulling on the hose. Hose or connections could fail and result in catastrophic high-pressure release of fluid as well as hose whipping.</p> <p><u>Avoid sharp objects.</u> Keep hose away from sharp objects. Bursting hoses may cause injury.</p> <p><u>No load bearing.</u> Do not use the pump to support other items of equipment that impose unacceptable loads on the pump. Do not attempt to use this machine as a prop.</p> <p><u>Lock trigger safety latch when not spraying.</u> Spray gun is equipped with a built-in trigger safety latch to guard against accidental trigger release. Rotate safety latch to the locked position when not spraying.</p> <p><u>Never leaving unattended.</u> Always turn off the pressure washer and relieve system pressure before leaving the sprayer unattended.</p> <p style="text-align: center;"><u>PROMPT EMERGENCY RESPONSE</u></p> <p><u>Seek medical aid for suspected injection injury.</u> If injured by high-pressure fluid, no matter how small the wound is, see a doctor at once. A typical injection injury may be a small puncture wound that does not look serious. However, severe infection or reaction can result if proper medical treatment is not administered immediately by a doctor who is familiar with injection injuries.</p> <p><u>Seek medical aid for suspected carbon monoxide poisoning.</u> The running engine gives off carbon monoxide, a poisonous gas that can kill you. If you start to feel sick, dizzy, or weak while using the pressure washer, shut off the engine and get to fresh air RIGHT AWAY. See a doctor. You may have carbon monoxide poisoning.</p>
<p>Put on Personal Protective Gear</p>	<p> WARNING: Use personal protective gear to prevent:</p> <ul style="list-style-type: none"> • Eye and skin injection injury from high pressure spray • Hearing loss • Burns from hot water or steam • Eye injury from flying debris <ul style="list-style-type: none"> • Wear waterproof, thermally insulated gloves, safety goggles, face protection, and protective clothing when operating the machine. If spraying pressure washer specific chemicals, wear a respirator mask to avoid inhalation of vapors if directed on the chemical label. • Wear non-slip, protective footwear. Use of pressure washer can create puddles and slippery surfaces. Wear footwear capable of maintaining a good grip on wet surfaces.
<p>Prime Water Supply</p>	<p>Prime the water supply.</p> <p> CAUTION: Never run the pump without the water supply connected and primed. Operating the pressure washer without enough incoming flow of water will damage the pump.</p> <p>Must use a tank feed: See Assembly and Initial Set-Up.</p> <ol style="list-style-type: none"> 1) Ensure the feed tank is full of water. 2) Make sure the supply hose from the tank is not kinked. A kinked hose will provide insufficient water supply to the

Operating the Pressure Washer

	<p>pump and reduce its life. Make sure the hose remains unknicked after moving the pressure washer.</p> <p>3) Purge air from the water supply hose by squeezing the trigger until a steady stream of water flows out of the nozzle at low pressure. (Air in the hoses can cause damage to the pump, so always make sure all the air is out of the hoses before starting the pressure washer engine.)</p> <p>Check adequacy of water supply:</p> <ol style="list-style-type: none"> 1) Make sure the water is clean. Debris can cause excess pump wear and reduce performance. 2) Make sure the water supply is steady and capable of flowing at a rate 20% over the rated flow of your pump. <p>CAUTION: An insufficient water supply will damage your pump.</p>
<p>Start Engine</p>	<p>Start the engine to power the pump.</p> <p>Note: For detailed engine operation and maintenance, always refer to the engine's owner's manual or the DSE3000 Series Control Module manual.</p> <ol style="list-style-type: none"> 1) Make sure water supply is connected and primed. <p>CAUTION: Running the pump dry will cause damage and void the warranty.</p> <ol style="list-style-type: none"> 2) To prevent accidental spraying, engage the safety latch on spray gun trigger by rotating it to the locked position. 3) Follow the instructions as shown below for starting the engine. <ul style="list-style-type: none"> • Turn the key switch clockwise to ON position. • Press Green button • Glow plugs will run their sequence before engine starts this could take up to 30 seconds. <p>- If the engine does not start on the first try, pressure may build up in the pump. Relieve pressure by squeezing the spray gun trigger before attempting to start engine again. This will make starting easier.</p> <p>▲ DANGER: DO NOT INHALE ENGINE EXHAUST. IT CONTAINS DANGEROUS CARBON MONOXIDE THAT CAN KILL YOU.</p>
<p>Apply Cleaning Chemical (if desired)</p>	<p>If desired, spray cleaning chemical at low pressure (with or without heated water).</p> <ol style="list-style-type: none"> 1) Make sure the chemical injector is properly set up according to the instructions in Step 2, Set Up for Chemical Spraying. 2) Make sure the low-pressure BLACK nozzle is attached before beginning to spray chemicals -- <i>Only the low-pressure black nozzle will allow chemicals to be drawn through the chemical injector into the water stream.</i> 3) You can apply chemicals with either warm or cold water. Check chemical label. If warm water is specified, start burner according to instructions provided below. 4) Apply chemicals by squeezing the spray gun trigger. The chemical injector will draw the chemical into the water stream. 5) Apply chemicals evenly to the cleaning surface. Never use more chemical than is necessary to clean the surface. 6) Allow the chemicals time to react with the dirt before rinsing. 7) Prepare to rinse by changing to a high-pressure nozzle. Changing the nozzle from the low-pressure black nozzle to a high-pressure nozzle will stop the flow of chemicals into the water stream. <p><i>Refer to instructions for selecting and changing the nozzle in Step 1, Connect Hoses, Water Supply, and Nozzle.</i></p> <ol style="list-style-type: none"> 8) Rinse with high-pressure spray, either hot or cold, as instructed below.

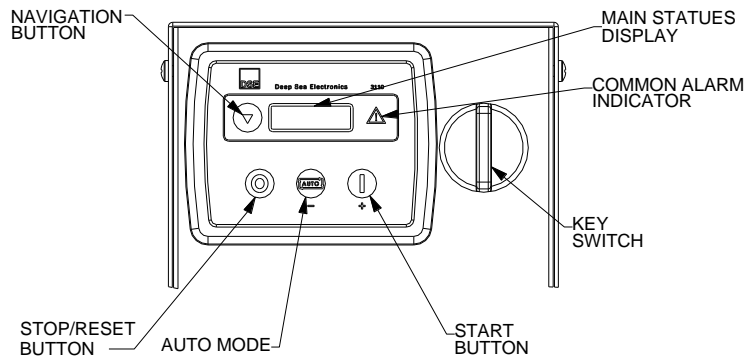

Operating the Pressure Washer

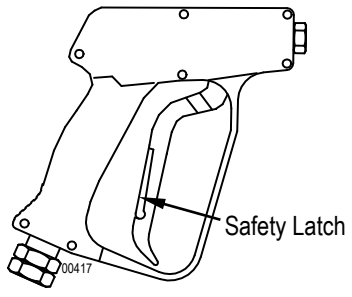
<p>Turn on Burner (if hot spray or steam is desired)</p>	<p>If HOT spray or steam is desired, turn on the burner:</p> <ol style="list-style-type: none">1) First make sure vicinity is free of flammable vapors, dust, gases, or other potentially combustible materials. Operate only where open flame or torch is permitted.2) Make sure there is fuel in the burner fuel tank. <p>CAUTION: Do not run the machine in hot mode without fuel in the burner's fuel tank, or damage can occur.</p> <ol style="list-style-type: none">3) Turn the heat switch ON and adjust the thermostat to the desired temperature.4) If steam is desired set the thermostat to 212°F or higher and use the yellow steam nozzle. <p>WARNING:</p> <ul style="list-style-type: none">• NEVER attempt to immediately run or re-light the burner if it does not ignite the first time. Unburned oil or gas may have accumulated, causing potential explosion or fire hazard.• Do not attempt to set temperature limit above the preset limit.• NEVER touch hot burner surfaces and stay clear of burner exhaust. All are extremely hot and will burn you.• Do not inhale burner exhaust. It contains dangerous carbon monoxide that can kill you. <ol style="list-style-type: none">5) The burner will fire when the trigger is squeezed – follow instructions for spraying. <p>NOTICE: If burner exhaust is white, adjust burner for peak performance. See the Maintenance & Repair section of this manual.</p> <ol style="list-style-type: none">6) When the trigger is released, a flow switch automatically turns the burner off. Also, when the temperature setting is reached, the thermostat automatically turns the burner off. <p>NOTICE: The blower fan will continue to run for approximately 90 seconds after thermostat is turned off.</p> <p>WARNING: It is important that the burner stops firing when the trigger is released. If the burner remains firing, discontinue use until the pressure washer is serviced. Extremely high temperatures can result in serious injury and equipment damage.</p>
<p>Begin High-Pressure Spray</p>	<p>High-Pressure Spray Procedure</p> <p>WARNING: High pressure spraying safety</p> <ul style="list-style-type: none">• Keep spray away from people. Never direct discharge stream at or near any person. Do not allow any part of the body to meet the fluid stream. High-pressure spray can cause serious skin, eye, or falling injuries, and hot water can burn. Injection injury will occur if high-pressure spray pierces the skin, injecting liquid under the skin. Injection injury can result in blood poisoning and/or severe tissue damage leading to infection, gangrene and possibly amputation. Seek medical attention.• Do not secure trigger open. To reduce risk of injury, do not attempt to secure the spray gun open by blocking or tying the spray gun in the open position.• Prevent slips / loss of balance. High-pressure spray could cause you to lose balance from kickback forces, and wet surfaces can be slippery.<ul style="list-style-type: none">- Always keep good footing and balance. Do not overreach.- Do not stand on unstable support when spraying.- If spraying from an elevated surface, use fall protection because spray gun kickback can propel you off the elevated surface. When spraying from a ladder or scaffolding, ensure it is firmly anchored from sway or tip-over.• Be aware of puddles and slippery surfaces. Ensure there is adequate drainage to prevent pooling of water.• Prevent surface damage & flying debris. Surfaces being sprayed must be strong enough to withstand high-pressure spray or damage may result. In addition, high-pressure spray will dislodge unsecured objects as well as 

Operating the Pressure Washer

surface chips and debris, resulting in hazardous flying objects that can cause personal injury or property damage. Do not spray brittle surfaces or breakable, fragile, or unsecured objects such as:

- stucco or laminar flagstone
- some painted surfaces
- windows or glass doors (because they may break)
- light fixtures, flowerbeds, mailboxes
- unsecured, lightweight objects

Procedure:

- 1) Put on one of the high-pressure spray nozzles (always relieve system pressure first and follow instructions for attaching a nozzle).
- 2) Clear the cleaning area of all persons. Keep children and pets away.
- 3) Hold the spray gun firmly with two hands and a sturdy stance: (gun kicks back when triggered).

▲ CAUTION: Spray gun metal gets extremely hot when using the burner and can burn you on contact. Never touch the metal screw or any metal parts of the spray gun when the heater is being used. Use only designated grip areas.

- 4) Wash from the bottom to the top, using side-to-side motions. This washes away heavy dirt and allows the detergent to soak as you work toward the top.
- 5) Use the width of the spray pattern to wash a wide path. Overlap the spray path for complete coverage.
- 6) The nozzle should be 12" to 24" from the work, closer for tough areas.
- 7) Small parts should be washed in a basket, so the pressure does not push them away. Larger, lightweight parts should be clamped down.
- 8) The pressure washer's unloader is adjustable. It is set and locked to the maximum rated pressure when it leaves the factory. To reduce the pressure, turn the unloader knob counter-clockwise, to return it to the factory set maximum pressure, turn clockwise.

▲ WARNING: Do not attempt to alter the unloader valve's maximum pressure.

Excess pressure could cause serious injury from escaping high-pressure fluids and/or pump damage. Any alteration other than turning the adjustment knob will void your warranty.

- 9) If temporarily interrupting spraying, rotate trigger safety latch downward to the locked position to guard against accidental trigger release.
- 10) Always turn off the engine and activate spray gun trigger to relieve system pressure when:

- the sprayer is unattended, or
- the operator is disconnecting hoses, installing/cleaning nozzles, or servicing the pump.

▲ WARNING: Always turn off the engine and relieve system pressure when finished spraying or when leaving sprayer unattended. Serious injury could result from unintentional release of high-pressure spray.

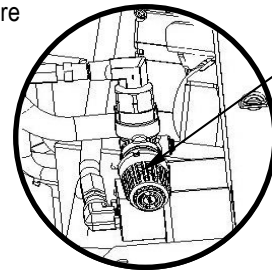

Turn counter-clockwise to reduce pressure.

Turn clockwise to increase pressure.

STEP 4. STOPPING

Stop the engine using the following steps:

▲ WARNING: Never disconnect the high-pressure hose from the pump or spray gun while the system is pressurized. Relieve pressure by squeezing the spray gun trigger after the engine is turned OFF.

- 1) If the heater was used, turn thermostat OFF.
- 2) Spray cold water for two minutes.
- 3) Turn heat switch OFF.
- 4) Turn engine OFF.

Squeeze trigger to relieve pressure.

Storing the Pressure Washer

STORAGE

When you are finished using the pressure washer, you must prepare the pressure washer for storage and store it in a proper location.

NOTICE: If you will be storing the pressure washer in freezing conditions, follow the instructions below on how to prepare the pressure washer for freezing conditions.

- If you will not be using the pressure washer again for 30 days or more, follow the instructions for preparing the engine for long-term storage.

⚠ WARNING:

- **Fuel and its vapors can ignite and cause a fire.** Select a well-ventilated storage area away from sources of heat, flame, or sparks.
- **A hot engine can ignite flammable materials.** Always let the engine cool at least five minutes before storing.

Detailed instructions are provided below.

<p>Choose a Storage Location</p>	<p>Choose a storage location that is:</p> <ul style="list-style-type: none"> • Clean and dry. • Away from sources of heat, open flames, sparks, or pilot lights, even if the pressure washer's engine and burner fuel tanks are empty. Residual fuel fumes from tank can ignite. • Away from extreme high or low temperatures. Do not store the pressure washer in freezing conditions unless it is prepared as directed below for those conditions.
<p>Perform Regular Maintenance</p>	<p>Perform periodic maintenance as directed in this manual to keep the pressure washer in safe working condition.</p>
<p>Prepare Pressure Washer for Freezing Conditions (if needed)</p>	<p>If you will be storing the pressure washer in freezing temperatures, you must properly prepare the pressure washer to prevent water from freezing in the system.</p> <p>⚠ CAUTION: Do not allow water to freeze in the pressure washer, high pressure hose, or spray gun. Freezing water can cause damage to the equipment and cause the spray gun to fail in the open position. A spray gun that has failed in the open position can whip around and cause personal injury when the pressure washer is started.</p> <p>Freeze protection:</p> <p>The use of RV antifreeze will save the components from freeze damage and keep them lubricated.</p> <ol style="list-style-type: none"> 1) Fill attached feed tank or a separate bucket with 5 gallons of RV antifreeze. <ul style="list-style-type: none"> • If feed tank has been used, drain water from it <u>first</u>. • If using a bucket, submerge one end of a short garden hose in the bucket and connect the other end to the water supply inlet on the pump. 2) Disconnect the high-pressure hose from the high-pressure water outlet. 3) Run the engine (with heat switch off) until RV antifreeze comes out of the high-pressure water outlet. 4) Make sure excess antifreeze is disposed of safely.
<p>Prepare Engine for Long Term Storage (if storing more than 30 days)</p>	<p>First prepare the engine for long term storage if you will not be using the pressure washer again for more than 30 days.</p> <p>Fuel can become stale when stored over 30 days. Stale fuel causes acid and gum deposits to form in the fuel system which can cause malfunction of the engine.</p> <ol style="list-style-type: none"> 1) Prepare fuel system for storage: <ul style="list-style-type: none"> • Remove all fuel from the tank and carburetor (if applicable). This is most easily accomplished by running the pressure washer with the high-pressure hose until the engine stops from lack of fuel. <p>OR</p>

Storing the Pressure Washer

	<ul style="list-style-type: none">• Add fuel stabilizer to the fuel (following manufacturer's instructions) Fuel stabilizer steps: <ol style="list-style-type: none">1. Ensure engine fuel tank is full.2. Add fuel stabilizer to fuel tank.3. Run pressure washer with high pressure hose at least 5 minutes after adding stabilizer to allow it to enter the fuel system.4. Shut off engine.
Prepare Pressure Washer for Storage	Prepare the pressure washer for storage. <ol style="list-style-type: none">1) Disconnect the battery, remove it from the battery compartment, and store it indoors above 32°.2) Make sure the engine start switch is OFF and fuel valve is OFF.3) Disconnect the engine spark plug wire if you have not already done so.
Move Pressure Washer to Storage Location	Let engine cool for 5 minutes before moving the pressure washer to its storage location.

Maintenance & Repair

BURNER ADJUSTMENT (only needed if white exhaust smoke appears)

The oil burner is preset, and performance tested at the factory (elevation 1100 feet). Different altitudes may require a one-time initial burner adjustment.

⚠ CAUTION: If white smoke appears from the burner exhaust vent during start-up or operation, discontinue use and readjust air bands.

Specific steps for burner correction are given below.

Burner Correction

Adjusting the burner will require you to access the burner of the pressure washer while someone else is operating the spray gun.

Detailed instructions:

- 1) Locate the Air Damper Lever on blower housing.
- 2) Make sure burner is cool to the touch before attempting to adjust.
- 3) Begin operation of the pressure washer and switch on the burner, as instructed in the operation section of the manual. Have someone operate the spray gun so the burner fires.
- 4) Locate the air damper lever (Figure 5 below). Observe the position of the arrow on the lever relative to the calibration numbers directly to the left. (0 is fully closed and 10 is fully open). (Note: Factory calibration starts out at close to 5-1/2).

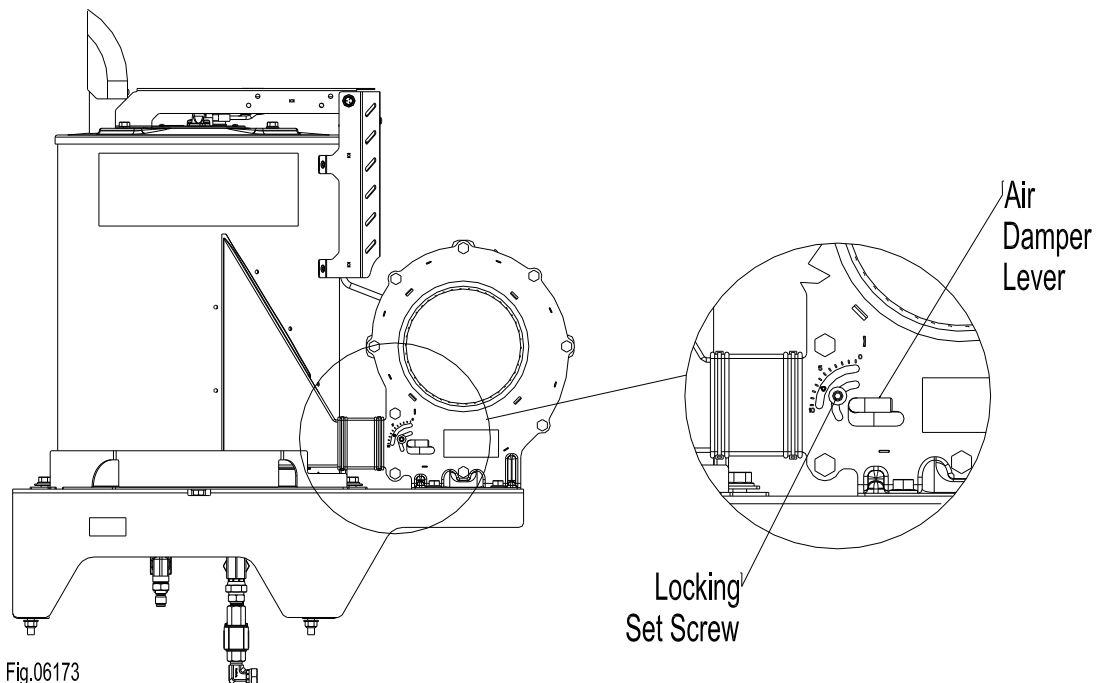

FIGURE 5

- 5) Locate and loosen the locking screw (Figure 5) and rotate the lever counter clockwise until black smoke appears from the burner exhaust vent. Note which number the arrow now points to.
- 6) Slowly open the lever until white smoke just starts to appear.
- 7) Turn lever halfway back to the black smoke position previously noted. Tighten the locking screw.

Maintenance & Repair

Inspect and maintain your pressure washer as specified below to keep it in safe and optimal working order. Follow all safety rules and recommended maintenance instructions

⚠ WARNING

ALWAYS shut off water supply or drain tank, relieve spray gun pressure, turn off engine and disconnect the spark plug before cleaning, adjusting, or servicing the pressure washer. After servicing, make sure all guards and cover shields are replaced before using.

MAINTENANCE SCHEDULE

<u>Task</u>	<u>Frequency</u>
Keep Pressure Washer Clean	As needed
Inspect Fuel System	Each use
Inspect Spray System	Each use
Clean Inlet Filter	Each use
Recharge and Maintain Battery	As specified in battery manufacturer's instructions
Perform Engine Maintenance	As specified in engine's owner's manual
Change Pump Oil	<ul style="list-style-type: none"> • After first 40 hours of use • Every 3 months or 500 hours of use after that
Maintain Burner's Fuel Filter / Water Separator	<ul style="list-style-type: none"> • Each Use • Change filter after every 500 hours of use
Descale Heating Coil	Annually, or more frequently as use and performance require (see instructions)
Inspect Heating Coil and Desoot	As needed
Inspect/Clean/Adjust Electrodes	Annually
Inspect/Tighten or Replace Pump/Generator Belts	After the first 24 hours of use, then with each oil change. Tighten or change belts as needed.
Inspect and Clean Flow Switch	As needed
Inspect/Replace Fuel Filter/Pump	Each use/as needed
Clean Chemical Strainer & Injector	Clean the strainer and injector. Always start with a clean detergent container. Run clean water through the injector after each use.
Clean Combustion Head Flame Sensor Lens	Clean combustion head flame sensor lens glass every 100 hours.

Maintenance & Repair

See detailed instructions for each maintenance item below.

(Note: For end-of-the-season storage instructions, see the "Storage" section of this manual.)

MAINTENANCE & REPAIR-DETAILED INSTRUCTIONS

<p>Follow Safety Rules</p>	<p>Read and follow these safety rules whenever you will be servicing the pressure washer:</p> <ul style="list-style-type: none"> • Turn off / relieve pressure first. Always turn off pressure washer and relieve system pressure before inspection or maintenance. Disconnect battery to prevent accidental starting. • Fuel valve off. Turn fuel shut-off valve to OFF position (if applicable) before transporting or servicing the pressure washer. • Replace guards. Make sure all guards and cover shields are replaced after servicing the pressure washer. • Major repair. If machine needs major service, including the installation or replacement of parts, a qualified service technician should only perform it. Obtain factory approved parts from NorthStar ProSHOT Product Support at 1-800-969-7073. • Replacement parts. If a part needs replacement, only use factory approved repair parts. Replacement parts that do not meet specifications may result in a safety hazard or poor operation of the pressure washer and will void the warranty.
<p>Keep Pressure Washer Clean</p>	<p>Keep pressure washer clean.</p> <p>If dust or debris accumulates on the pressure washer, clean the pressure washer with a damp cloth or soft bristle brush. Do not allow air intakes to become blocked.</p> <p>CAUTION: Do not spray pressure washer with a garden hose or pressure washer. Water may enter the pressure washer and cause damage.</p>
<p>Inspect Fuel System(s)</p>	<p>Inspect the fuel systems (of both engine and burner) and check for leaks before each use.</p> <p>Do not start pressure washer until all needed repairs have been completed.</p> <p>⚠ WARNING: Fuel leak hazard. Engine fuel and burner fuel are highly explosive and fuel leaks can result in fire or explosions. You can be burned and seriously injured if the fuel system is not properly hooked up or there is a fuel leak when you start the engine.</p> <p><u>Inspect the entire fuel system, for both engine and burner. Look for:</u></p> <ul style="list-style-type: none"> • Signs of leaks or deterioration, • Chafed or spongy fuel hose, • Loose connections, • Loose or missing fuel hose clamps, • Damaged fuel tank, or • Defective fuel shut-off valve
<p>Inspect Spray System</p>	<p>Inspect spray system for damage and leaks before each use.</p> <p>Do not start pressure washer until all needed repairs have been completed.</p> <p>⚠ WARNING: High pressure fluid injection hazard High pressure fluid discharge from leaks (even pin-sized) or ruptured components can pierce skin and inject fluid into the body. Injection injury can result in blood poisoning and/or severe tissue</p> <div data-bbox="812 1545 1539 1892"> <p>Water dripping or spraying, or localized moisture</p> <p>Exposed wire mesh due to wear</p> </div>

Maintenance & Repair

	<p>damage leading to infection, gangrene, and possibly amputation.</p> <ul style="list-style-type: none"> • Never use a finger or skin to check for leaks. • Never operate machine with damaged or missing hoses/parts. • Never attempt to repair a high-pressure hose or component. Always replace it with a part that is rated at or above the pressure rating of this machine. <ol style="list-style-type: none"> 1) Check hoses, fittings, wand, trigger gun and connections for signs of wear, cracks, looseness, or leaks. Replace as required. 2) Check and clean the nozzle orifice.
<p>Clean Inlet Filter</p>	<p>Clean the water filter before each use.</p> <p>⚠ WARNING: When cleaning filters, check whether dangerous chemicals have been used with the filter and take any precautions that may be recommended by the manufacturer of these chemicals. Always dispose of hazardous fluids per local, state, and national guidelines.</p> <p>Self-cleaning method:</p> <ol style="list-style-type: none"> 1) Locate water filter on pump inlet hose. (See the Inlet Filter reference in the parts explosion section.) 2) Make sure there is water in tank. 3) Turn the red knob counterclockwise open. Allow the water to run thru the hose barb for a minute or two. Turn clockwise to close. <p>Manual cleaning method:</p> <ol style="list-style-type: none"> 1) Disassemble filter housing. 2) Remove filter. 3) Run under water to clean. Note: The filter can be ordered separately if it becomes damaged. (See the Inlet Filter reference in the parts explosion section.) 4) Reassemble.
<p>Recharge and Maintain Battery</p>	<p>Inspect, recharge, and maintain battery according to your battery manufacturer's instructions.</p> <p>Do not store with battery charger always connected. Batteries that are over-charged can boil themselves dry and produce excessive amounts of hydrogen, an explosive gas.</p>
<p>Perform Engine Maintenance</p>	<p>Perform engine maintenance as specified in the engine owner's manual.</p> <p>Engine maintenance items include:</p> <ul style="list-style-type: none"> • Changing oil and oil filter if applicable. • Check Air filter replace if necessary. • Fuel filter check/replacement. • Inspecting and cleaning muffler (and spark arrestor if equipped).
<p>Change Pump Oil</p>	<p>Change the pump oil after the first 40 hours of use, and then after every 3 months or 500 hours of use after that.</p> <ol style="list-style-type: none"> 1) Remove cap from oil drain hose on pump. 2) Drain the pump oil into suitable container and dispose of responsibly. 3) Replace cap on oil drain hose. 4) Make sure unit is sitting level. Fill pump with 33.8 oz. of SAE30 non-detergent oil to middle of sight glass (or at the indicator line on the dipstick if equipped). 5) Reinstall oil fill dipstick.

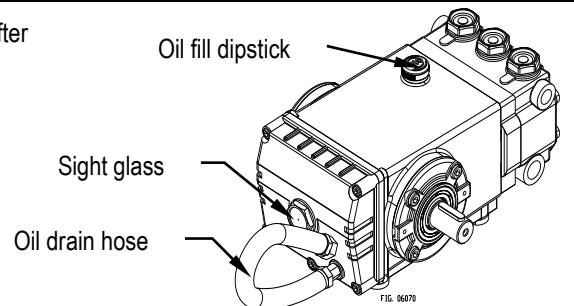
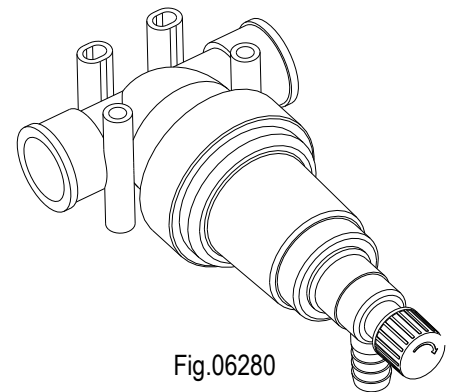

Maintenance & Repair

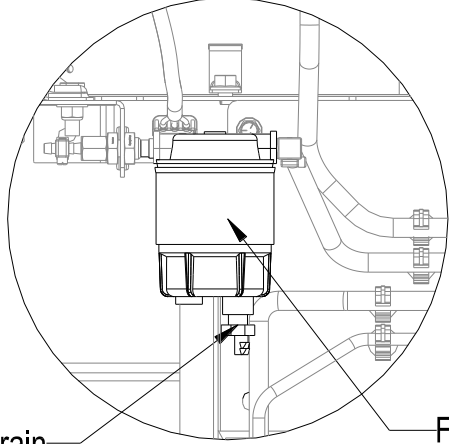
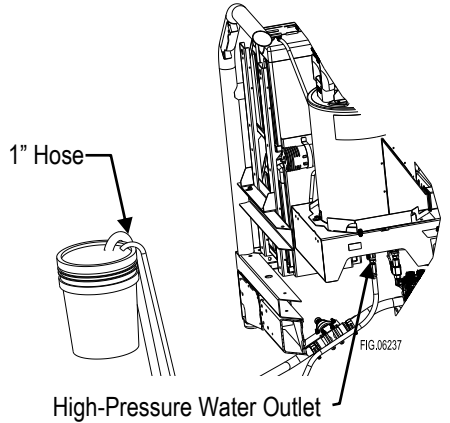
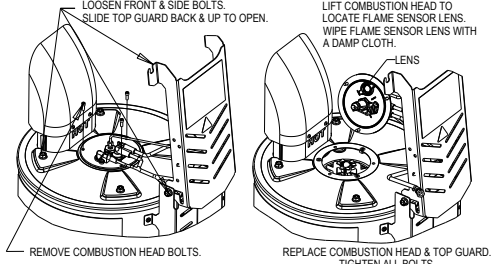
<p>Maintain Burner's Fuel Filter/Water Separator</p>	<p>Drain water from burner's filter bowl before each use and replace filter after every 500 hours of use or as needed.</p> <ol style="list-style-type: none"> 1) After each use of the burner, visually check the filter bowl. If any water has accumulated, drain it via the water drain at the bottom of the bowl. 2) After every 500 hours of operation, empty the burner's fuel tank to remove the filter bowl and inspect the fuel filter/water separator. Replace filter as needed. <p>Important: Always empty the burner's fuel tank before removing the filter bowl. There is no shut-off valve between fuel filter/water separator and burner's fuel tank.</p>	 <p>Water Drain</p> <p>Filter Bowl</p> <p>Fig. 06224</p>
<p>Descale Heating Coil</p>	<p>Descale coil tubing annually or more frequently as needed.</p> <p>In hard water areas, scale can build up inside the heating coil tubing. Scale deposits will decrease the output pressure and temperature of heated spray and may eventually clog water flow through the heating coil.</p> <p>Descale the coil tubing at least annually and more frequently if you detect a decrease in output pressure or temperature.</p> <p>To descale the coil:</p> <ol style="list-style-type: none"> 1) Mix a commercial coil cleaner in a 5-gallon bucket and elevate the bucket so it is higher than the unloader. If you are using a feed tank, fill the tank with enough solution to cover the supply bulkhead by 2" or more. This will ensure air is not drawn into the pump. 2) Attach the high-pressure hose(s) to the high-pressure water outlet on the machine. Do not hook up the spray gun. 3) Place the other end of the high-pressure hose(s) in the 5-gallon bucket. 4) Attach the 1" Hose to the inlet on the pump. 5) Prime the pump by filling the hose with water, then placing the end of the hose in the bucket. 6) Run the pressure washer in cold mode for 1 to 3 hours, recirculating the cleaning solution. 7) You may need to top off the bucket with more solution once the lines are full. <p>⚠ WARNING: DO NOT RUN THE BURNER. The chemical used to descale could have an adverse effect and emit harmful vapors or fumes.</p> <ol style="list-style-type: none"> 8) Dispose of the cleaning solution where it is not harmful to animals or the environment. 9) Flush with fresh water and clean the inlet strainer when finished. 	 <p>1" Hose</p> <p>High-Pressure Water Outlet</p> <p>FIG.06237</p>
<p>Clean Combustion Head Flame Sensor Lens</p>	<p>Clean combustion head flame sensor lens every 100 hours. If the flame sensor lens gets sooted up the flame sensor will not be able to sense a flame therefore the burner will not fire.</p>	<p>CLEAN COMBUSTION HEAD FLAME SENSOR LENS EVERY 100 HOURS</p> <p>TOOLS REQUIRED: 1/2" SOCKET AND WRENCH, 5/32" HEX KEY ALLEN WRENCH.</p> <p>LOOSEN FRONT & SIDE BOLTS. SLIDE TOP GUARD BACK & UP TO OPEN.</p> <p>LIFT COMBUSTION HEAD TO LOCATE FLAME SENSOR LENS. WIPE FLAME SENSOR LENS WITH A DAMP CLOTH.</p>  <p>REMOVE COMBUSTION HEAD BOLTS.</p> <p>REPLACE COMBUSTION HEAD & TOP GUARD. TIGHTEN ALL BOLTS.</p> <p>DONT CONTAMINATE OR TOUCH THE TIP OF THE FUEL NOZZLE WHILE PERFORMING THIS SERVICE.</p>

Maintenance & Repair

<p>Inspect Heating Coil and Desoot</p>	<p>Inspect and desoot coil annually.</p> <p>Most coils never require desooting. However, poor grades of fuel oil or inadequate combustion air will cause heavy soot build-up on the outside surface of the heating coil tubing. These deposits will insulate the coil, which then restricts air flow through the heat exchanger and further aggravates the soot build-up. Be sure to wipe the sight glass.</p> <p>If soot has built up on the exterior of the coil tubing, clean as follows:</p> <ol style="list-style-type: none"> 1) Wear protective clothing, goggles, and gloves. 2) Disconnect Fuel line from outer cover. Disconnect Flame sensor and High Tension Leads from black box bolted to the guard on side of Outer Wrap (see Parts Explosion Heat Exchanger & Blower Housing). 3) Remove (4) 5/16" Bolts from Outer Cover. 4) Remove Outer Cover set aside. 5) Remove (4) 5/16" bolts and nuts off the hold down brackets on the Outer Wrap. 6) Remove all inlet and outlet fittings. 7) Remove the (2) 1-1/4" Jam nuts and the 3/8" bolt underneath the base. 8) Lift off Outer Wrap, Inner Wrap, and Inner Cover. Set aside. 9) Using a couple of straps, wrap them around the Coil and attach to a hoist to lift off. You may also use the lifting eyes with hooks to lift with hoist. This coil weighs at least 125 lbs. If no hoist is available, it is recommended that this become a 2-man job each with the ability to lift at least 65 lbs. 10) Clean the coil. 11) Reassemble the coil and lids to the machine. Make sure the white insulation remains in place. 12) Reattach high-pressure hose and thermostat and make sure all fittings are tight before using the machine. 	
<p>Inspect/Clean Electrodes</p>	<p>Inspect electrodes yearly.</p> <ol style="list-style-type: none"> 1) Loosen front (2) bolts using a 1/2" socket. Loosen side (2) bolts using a 1/2" socket and wrench. 2) Remove (3) screws using a 5/32" hex key Allen wrench from the combustion head. Lift off combustion head from outer cover. 3) Disconnect flame sensor and electrode wires. Disconnect fuel line. 4) Clean off carbon deposits, which may have accumulated on the tips of the electrodes. 5) If electrodes are outside of manufacturing specification, replace electrodes. <p>NOTICE: Wipe combustion head flame sensor lens every 100 hours. If the flame sensor lens gets sooted up the flame sensor will be unable to sense a flame and therefore the burner will not fire. Do not contaminate or touch the fuel nozzle tip.</p>	

Maintenance & Repair

Inspect/Tighten or Replace Pump/Generator Belts

Check drive belt and generator belt after the first 24 hours of use, then with each oil change. Tighten or change belts as needed.

⚠ WARNING: Belt slippage can cause static electricity build-up, which may result in sparking. Fire ignition can result.

NOTICE: Belt tension and alignment are inter-related. Do not adjust one without checking the other.

To tighten belts:

- 1) Make sure engine is off.
- 2) Remove belt guard. See "Parts Explosion (Pump, Engine, & Generator)/Belt Guard" section of this manual for location.
- 3) Locate tensioner arm.
- 4) Using a straight edge make sure the pulleys are aligned with each other.
- 5) Loosen rear 1/2" tensioner bolt with 3/4" socket. (Keep partially torqued to aid in tensioning)
- 6) Loosen front 1/2" tensioner bolt with 3/4" socket.
- 7) Using a 1/2" square drive, move the tensioner plate so notch lines up as shown. An extension is recommended for the pump tensioner.
- 8) Retighten the front and rear bolts.

NOTE: Proper tensions for pump and generator belts below are for new belts only.
- 9) Replace the belt guard.

⚠ DANGER: Do not operate unless the belt guard is in place to prevent access to rotating parts. Clothing or hair can become rapidly entangled in unguarded rotating parts, resulting in serious injury or death.

NOTICE: Some general rules for belt tensions are:

- The ideal tension is the lowest tension without belt slippage.
- Over tightening decreases belt and bearing life.
- Keep belts clean and free of foreign material that may cause slippage.

Check Generator tension using a straight edge. Belt will have about 1/4" deflection with 5-7lbs of force.

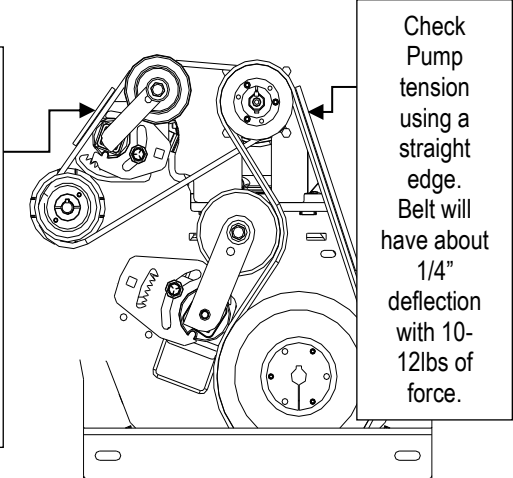

MAKE SURE THE PULLEYS ARE ALL EVEN WITH EACH OTHER

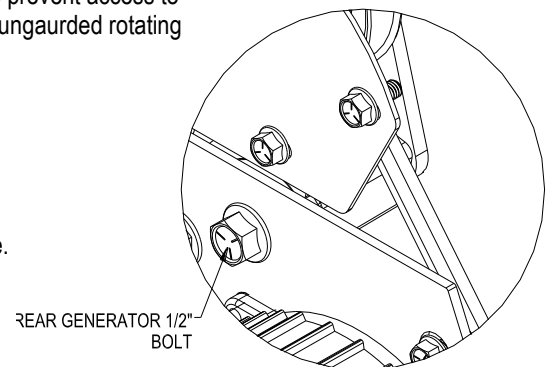
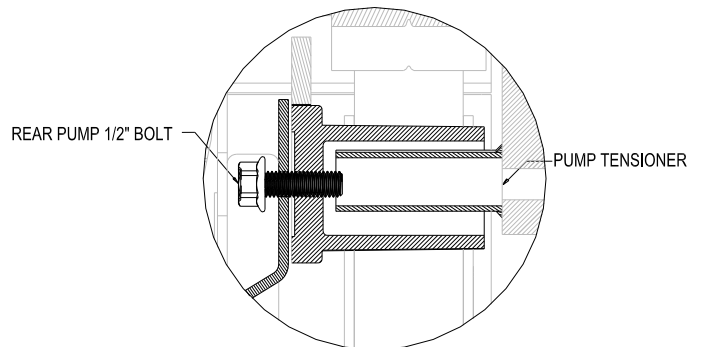
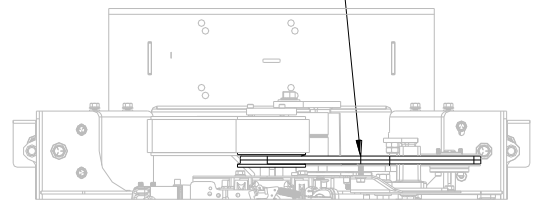

Maintenance & Repair

- Do not apply belt dressing, which can cause damage and early belt failure.

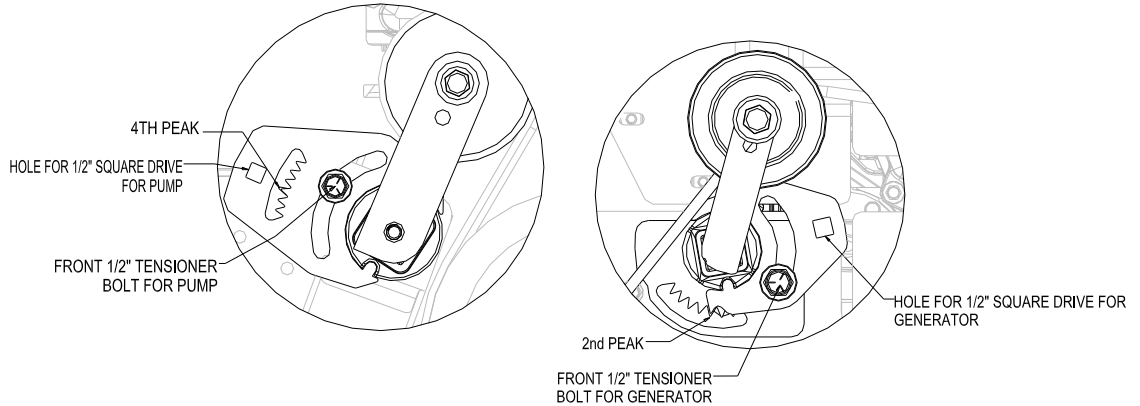

Inspect and Clean Flow Switch

Inspect and clean flow switch as needed. Mineral build-up and/or debris within the flow switch can occur and may affect burner operation if not periodically cleaned. Mineral build-up and/or debris can stop the movement of the shuttle inside the flow switch body. Shuttle movement is important because the burner will not fire if the shuttle does not move. The shuttle movement actuates a switch inside the flow switch housing which allows the burner to fire during spray mode.

- 1) Disconnect the swivel fitting from elbow to the inlet of the coil.
- 2) Remove the Cap fitting from the flow switch.
- 3) Slide out the Shuttle Assembly. If the magnet in the shuttle assembly is damaged or missing, replace the entire flow switch assembly. To order a replacement flow switch assembly, call NorthStar ProSHOT Product Support at **1-800-969-7073**.
- 4) Observe the Shuttle Assembly and internal portion of Body for obstructions, hard water deposits and any other foreign debris. Remove the foreign debris with light scraping or compressed air. If no additional cleaning is required continue to Step 7. If additional cleaning is required continue to step 5.

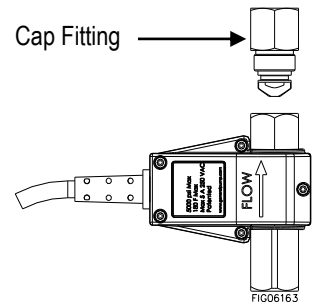
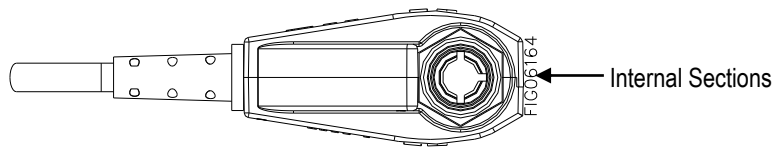
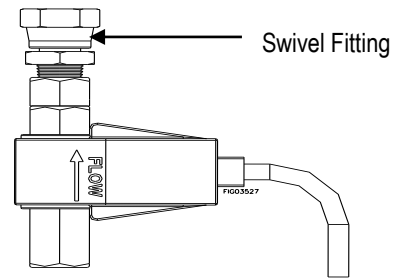

- 5) Remove the Body from the plastic Enclosure and soak the Body in CLR or similar solution to dislodge excess buildup. The screws (QTY 5) in the Enclosure are TORX T10.

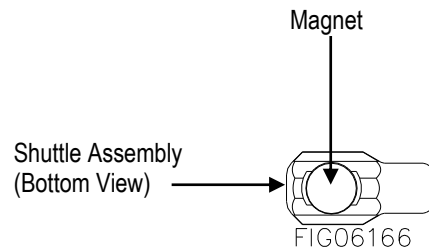
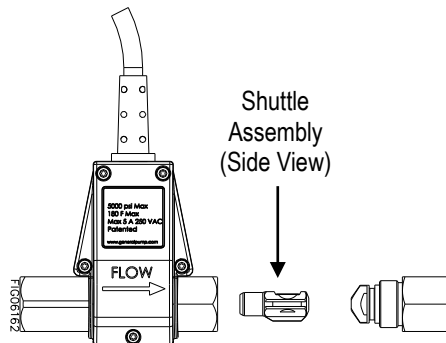

Maintenance & Repair

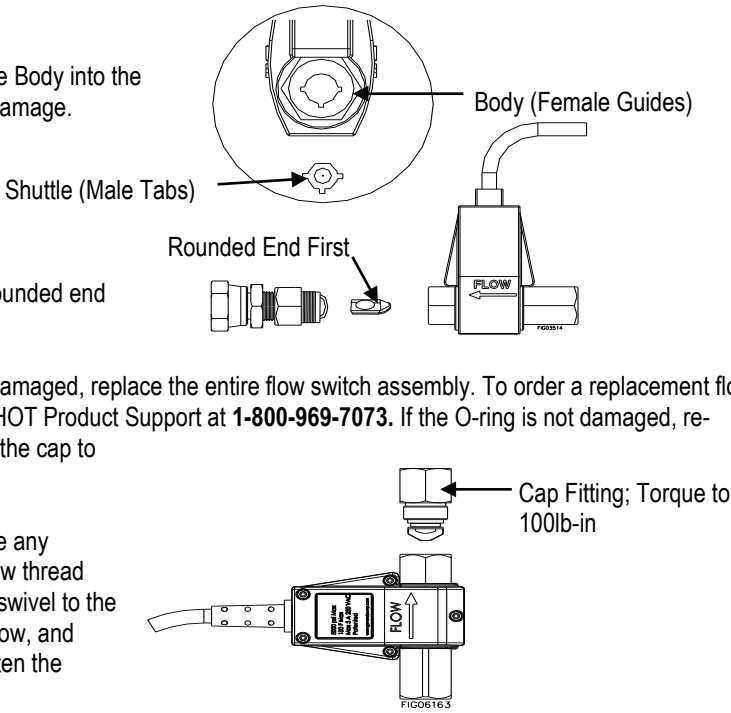
	<p>6) Rinse body.</p> <p>7) When cleaning is complete reinstall the Body into the Enclosures, taking care not to cause damage.</p> <p>8) Tighten the Screws into the body until they are snug. Do not over-tighten the screws.</p> <p>9) Insert the Shuttle Assembly with the rounded end first, into the body. Align with grooves.</p> <p>10) Inspect the O-ring on the Cap, if it is damaged, replace the entire flow switch assembly. To order a replacement flow switch assembly, call NorthStar ProSHOT Product Support at 1-800-969-7073. If the O-ring is not damaged, re-install the Cap onto the Body. Torque the cap to 100lb-in.</p> <p>On the elbow on the inlet of the coil, remove any remaining thread tape/sealant. Re-apply new thread tape/sealant on the elbow. Re-connect the swivel to the elbow. Hand-tighten the swivel onto the elbow, and once snug, using a wrench continue to tighten the swivel two additional revolutions.</p> 
<p>Inspect/Replace Fuel Filter/Pump</p>	<p>Check fuel filter and fuel pump when inspecting fuel lines. Change/replace as needed. (See the Parts Explosion for locations: Skid and Roll Cage.)</p>
<p>Clean Chemical Strainer and Injector</p>	<p>Clean the strainer and injector. Always start with a clean detergent container. Run clean water through the injector after each use.</p>
<p>Brush Assembly Maintenance</p>	<p>Inspect brushes every 12 months, or 200 hours. Replace brush assembly after 1000 hours of operation. Hours of operation and environmental conditions influence brush life. Look for excessive or uneven wear, if either condition is present, take the unit to a qualified repair technician.</p>

NOTE TO COMMERCIAL USERS:

All mechanical equipment, no matter how well designed, will need maintenance and repairs. A NorthStar ProSHOT pressure washer is no exception times, a NorthStar ProSHOT pressure washer may become inoperable because repairs are required. NorthStar ProSHOT Product Support will assist these repairs as needed, but if an inoperable pressure washer creates a major expense to your business, then we strongly recommend the following:

- Have a staff person become familiar with the mechanical operation of the pressure washer and capable of making minor repairs and performing all preventative maintenance procedures.
- Keep a stock of recommended service parts for maintenance and minor repairs.

IMPORTANT: If a part needs replacement, only use parts that meet the manufacturer’s part number specifications. Replacement parts that do not meet specifications may result in a safety hazard or poor operation of the pressure washer.

Maintenance & Repair

ENGINE WILL NOT START

<u>Causes</u>	<u>Solutions</u>
Low oil shutdown	Fill engine with the adequate amount of oil.
Cold engine	Choke engine to start.
No fuel	Add fuel.
Dead battery	Recharge/Replace battery.
Spark plug wire not attached (If equipped)	Attach spark plug wire to spark plug (If equipped).

PRESSURE WASHER RUNS BUT BURNER DOESN'T FIRE

<u>Causes</u>	<u>Solutions</u>
Heat switch turned OFF	Turn heat switch ON.
Thermostat set too low or off	Set thermostat to desired temp.
Fuel tank empty	Fill fuel tank with kerosene, diesel, or fuel oil.
Defective Flow Switch	Call Product Support.
Defective Burner	Call Product Support.

PRESSURE WASHER RUNS BUT NO PRESSURE

<u>Causes</u>	<u>Solutions</u>
Partially clogged or damaged nozzle	Clean or replace nozzle.
Clogged water filter	Clean water filter.
Low water flow	Make sure the water supply is at least 9.6 gpm.

PRESSURE WASHER SURGES OR CYCLES WHILE IN BYPASS

<u>Causes</u>	<u>Solutions</u>
Leak between unloader and gun	Check all connections between unloader and gun for leaks. Tighten loose components and replace damaged components.
Gun leaking internally	Replace spray gun.

SMOKE FROM HEAT EXCHANGER

<u>Causes</u>	<u>Solutions</u>
Air band not adjusted properly	Adjust the air band until the burner burns cleanly. See Installation Instructions.
Poor quality fuel	Use kerosene for the cleanest burn.

WATER NOT HEATING SUFFICIENTLY

<u>Causes</u>	<u>Solutions</u>
Scale build-up in coil	See Coil Descaling under Maintenance Instructions.
Coil is full of soot	See Coil Desooting under Maintenance Instructions.
Combustion Head Flame Sensor Lens is full of soot	See Clean Combustion Head Flame Sensor under Maintenance Instructions.

RUPTURE DISC SPRAYS WATER

<u>Causes</u>	<u>Solutions</u>
Pressure Washer/Burner Control Problem	Call Product Support.

POOR OR NO DETERGENT SUPPLY

<u>Causes</u>	<u>Solutions</u>
Inadequate detergent supply	Refill detergent container. Be sure chemical strainer is fully submerged.
High pressure hose too long	Use less hose. Move machine closer to the work.
Chemical strainer or injector clogged	Clean the strainer and injector. Always start with a clean detergent container. Run clean water through the injector after each use.

Major Components – REV. E.1

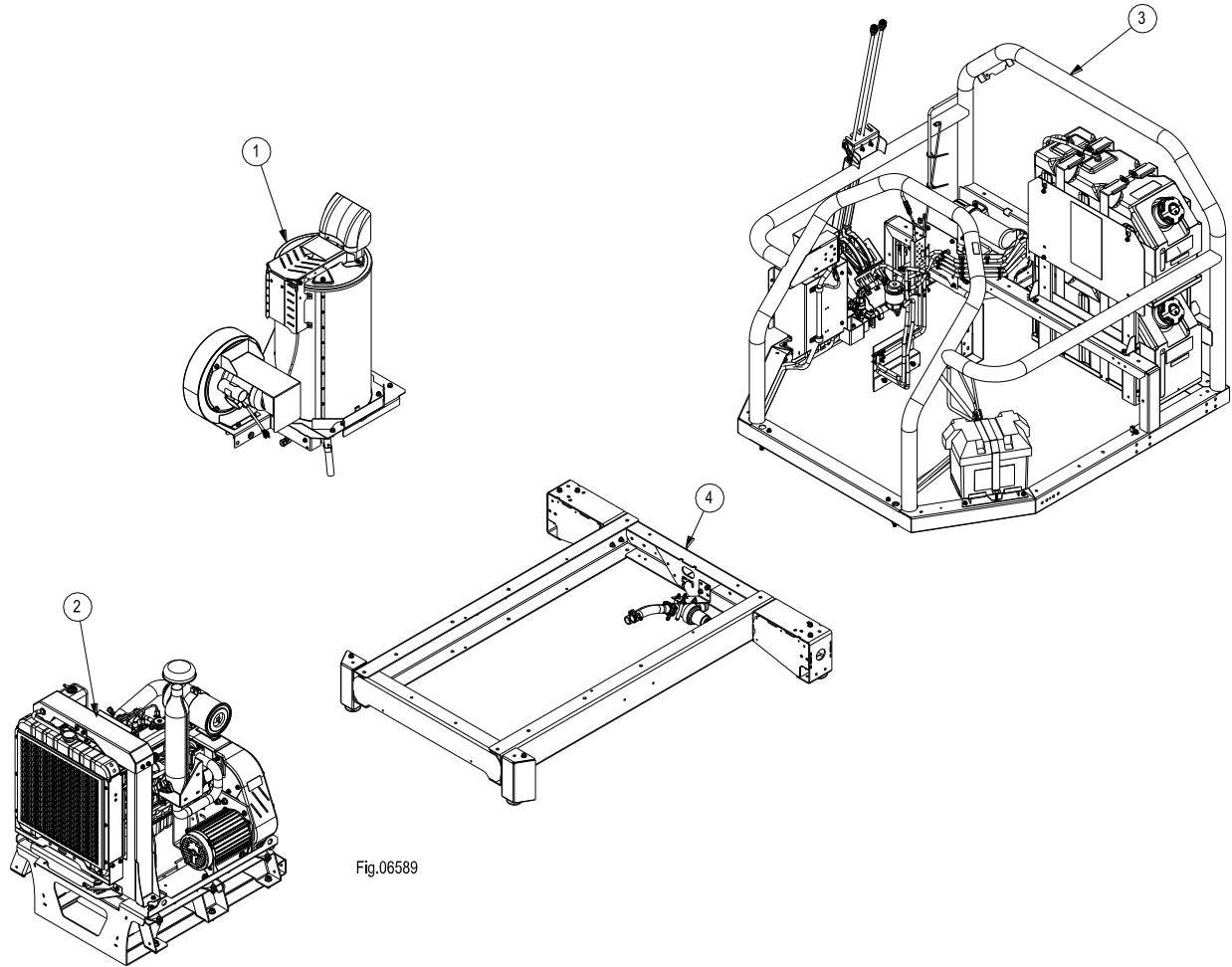

Fig.06589

MAJOR COMPONENTS (FIG.06589)

<u>Ref. #</u>	<u>Description</u>	<u>Figure #</u>
1	Heat Exchanger	06442
	Blower Housing	06443
2	Pump, Engine, & Generator	06295
3	Skid (Roll Cage)	06292
4	Skid Frame	06346

These components go into more detail on the following pages.

Parts Explosion (Heat Exchanger/Blower) – REV. E.1

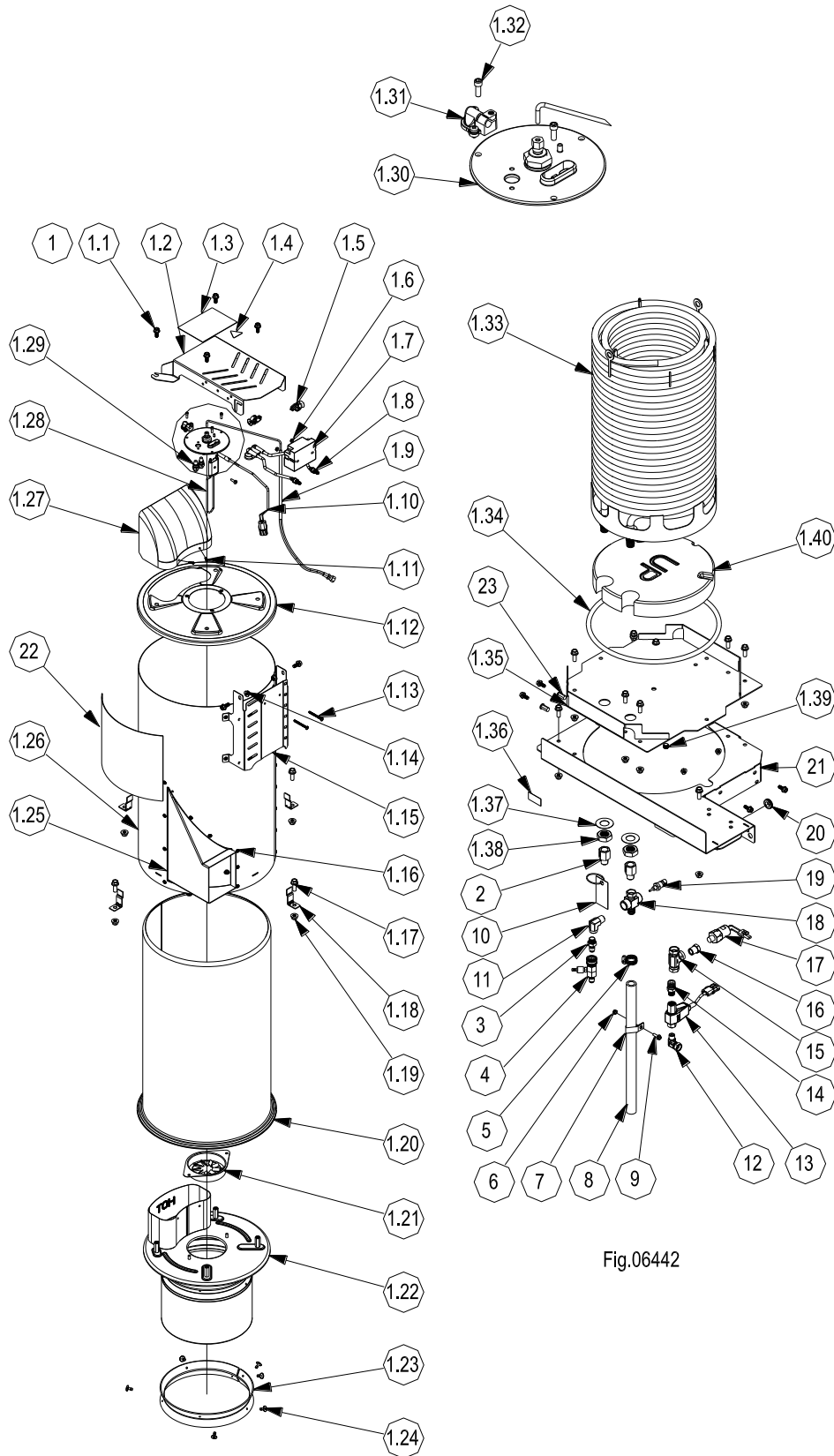

Fig.06442

Parts Explosion (Heat Exchanger/Blower) – REV. E.1

HEAT EXCHANGER (FIG.06442)			
Ref. #	Part #	Description	Qty.
1	798394	Large Heat Exchanger Assembly	1
1.1	82621	Bolt, 5/16-18 x 3/4" hex head flange	6
1.2	797692	HX Fuel Line Guard, Top	1
1.3	798383	Decal, Flame Sensor Lens Cleaning Instructions	1
1.4	796496	Decal, ISO Electric Shock Warning Triangle	1
1.5	793645	Hose/Wire Clip, 1/2"	6
1.6	82065	Nut, #10-24 nylon insert lock	2
1.7	792260	Igniter, 120V	1
1.8	792262	High Tension Lead Wires	1
1.9	794151	Fuel Line, Large HX	1
1.10	792286	Flame Sensor	1
1.11	82004	Screw, #8-32 x 1/2" button head cap	2
1.12	797663	Outer Cover, HX	1
1.13	82245	Screw, #10-24 x 2" pan Phillips thread cutting	2
1.14	82630	Nut, 5/16-18 nylon insert lock	2
1.15	797649	HX Fuel Line Guard, Side	1
1.16	82649	Blind rivet, 3/16"	23
1.17	82624	Bolt, 3/8-16 x 1" hex head flange, Gr. 5	13
1.18	792135	Hold Down BRKT, HX	4
1.19	82631	Nut, 3/8-16 hex flange nylon	12
1.20	792132	Inner Wrap, Large, HX	1
1.21	799015	AJR, 107mm	1
1.22	797075	Inner Cover WLDT, XL Exhaust, HX+	1
1.23	792248	Gasket	1
1.24	82660	Rivet, 3/16 large flange	6
1.25	797583	Angled Intake Duct Weldment, 8 GPM, HX	1
1.26	797586	Outer Wrap, 8 GPM	1
1.27	797696	Rain Cap, Exhaust Vent	1
1.28	799679	Electrodes, HX 8GPM	1
1.29	799677	Fuel Nozzle, 2.00 GPH	2
1.30	799304	Dual Combustion Head Assembly, HX	1
1.31	793595	Flame Sensor BRKT Kit	1
1.32	82006	Screw, 10-32 x 1/2" button head cap	3
1.33	791884	Coil WLDT, 160ft	1
1.34	792224	Gasket, HX Bottom	1
1.35	792136	Base WLDT, HX	1
1.36	797513	Decal, Burn Hazard	1
1.37	82606	Washer, 1" ID x 2" OD copper	2
1.38	82605	Nut, 1"-14 jam	2
1.39	777838	Plug, hex 1/4" counter sunk	1
1.40	792223	Firebrick insulation	1
2	779847	Adapter, 8MP-8FP	2
3	777913	Nipple, Male O.C. 3/8"	1

Parts Explosion (Heat Exchanger/Blower) – REV. E.1

HEAT EXCHANGER (FIG.06442) Continued			
Ref. #	Part #	Description	Qty.
4	NA	Chemical Injector, Assembly	1
4.1	799571	Chemical Injector, 2.3, 3/8" high draw	1
4.2	777914	Coupling, QC 3/8" FNPT	1
4.3	777915	Nipple, QC 3/8" x 3/8" FNPT	1
5	17141	Clamp, 3/4" loop	1
6	82222	Nut, 1/4"-20 nylon insert lock	1
7	779666	Clamp, 1" loop	1
8	793836	Hose, 3/4" Rupture Disc Discharge	1
9	82009	Bolt, 1/4"-20 X 3/4" HHSF	1
10	798057	Hangtag, Rupture Disk Warning	1
10.1	32821	Lanyard, Hangtag Warning	1
11	796493	1/2 MPT x 3/8" FPT, Elbow	1
12	797199	Elbow, 3/8 MPT x 3/8 FPT swivel	1
13	796492	Switch, Flow 12.0GPM 5000psi WP SSN	1
14	777337	Nipple, Hex 8MP-6MP	1
15	793967	Fitting, 1/2" NPT Swivel Tee	1
16	30048	Reducer 8MP-6FP	1
17	793964	Hi-PSI Limit, 6500PSI	1
18	798188	Fitting, Coil outlet manifold with rupture disk	1
19	793966	NTC Thermistor, 10K0HM	1
20	787403	Grommet	1
21	798423	Large Heat exchanger Base	1
22	798010	Decal, Kubota HX	1
23	82651	Rivet nut, 5/16-18 .31-.157	2
*	82141	Key, Shaft 3/16" X 1-1/2" for motor	1

Parts Explosion (Heat Exchanger/Blower) – REV. E.1

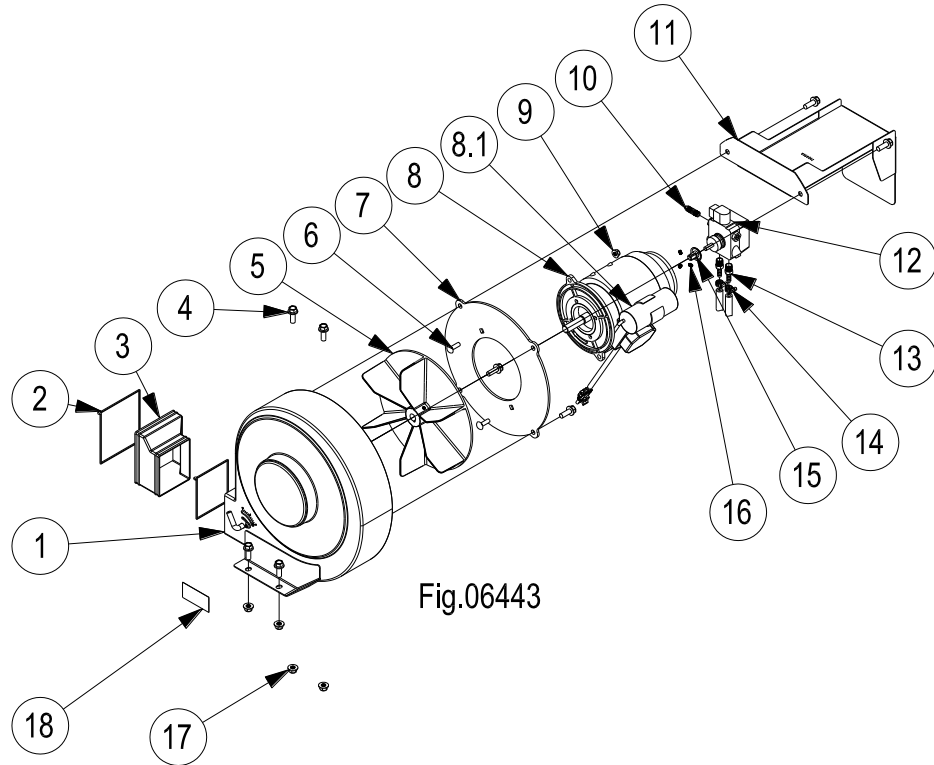

Fig.06443

BLOWER HOUSING (FIG.06443)

Ref. #	Part #	Description	Qty.
1	797652	HX 8GPM blower housing	1
2	82155	Tie, cable black, 50# 11	2
3	797647	HX intake boot, 8 GPM	1
4	82624	Bolt, 3/8-16 X1" hex head	2
5	797555	HX 8GPM blower impeller	1
6	82090	5/16 X .75 HHFB	2
7	797554	HX 8 GPM blower, motor mount	1
8	798404	Motor, 120VAC 736W	1
8.1	799381	Capacitor, HX Motor, 120VAC 736W	1
9	82630	5/16 Flange Nyloc nut	1
10	794146	Fitting, 1/4" JIC to 1/8"	1
11	798456	8GPM fuel pump heat Shield	1
12	796682	Pump, fuel 120V 55 gear	1
13	777340	Barb, Hose 1/4 MPT x 1/4	2
14	777834	Clamp, 1/4" hose	2
15	798493	Coupler, Pump/Motor	1
16	82613	M6-1X8 set screw	3
17	82631	Nut, 3/8-16" hex flange	2
18	786632	Decal, Rotating Mach	1
-	82319	Screw, Set 5/16"-18	2

Parts Explosion (Pump, Engine, & Generator) – REV. E.1

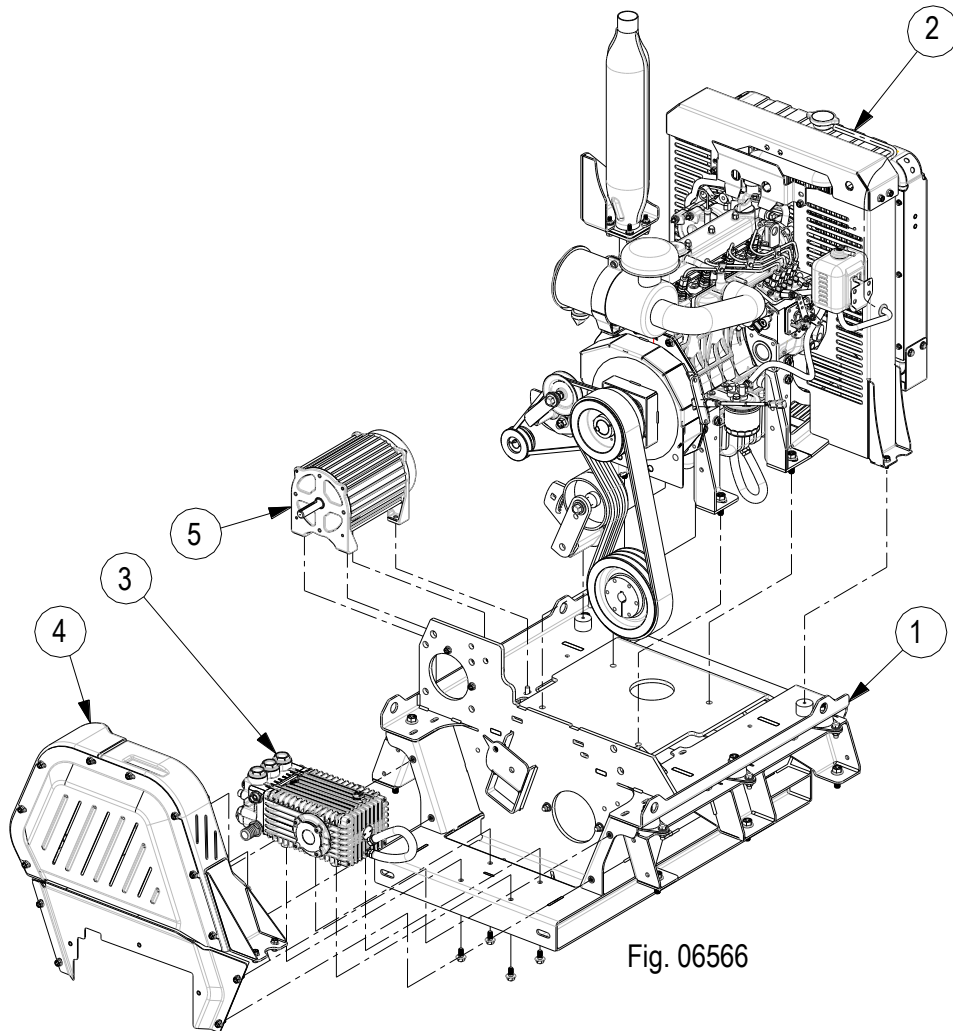

Fig. 06566

PUMP, ENGINE, GENERATOR (FIG.06566)

Ref. #	Description	Figure #
1	Engine/Belts/Pulleys	06498
2	Pump, Engine and Generator Base with ISO Mounts	06597
3	Pump	06698
4	Belt Guard	06499
5	Generator	06569

Parts Explosion (Pump, Engine, & Generator) – REV. E.1

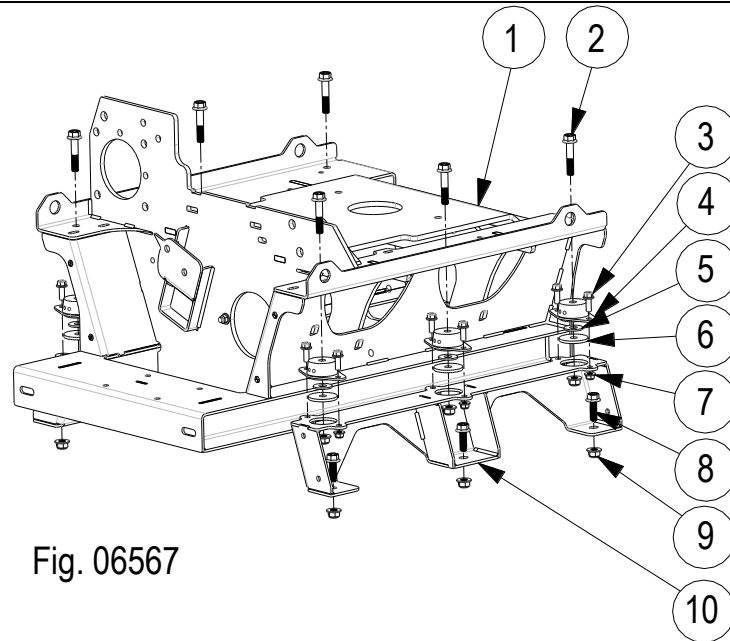
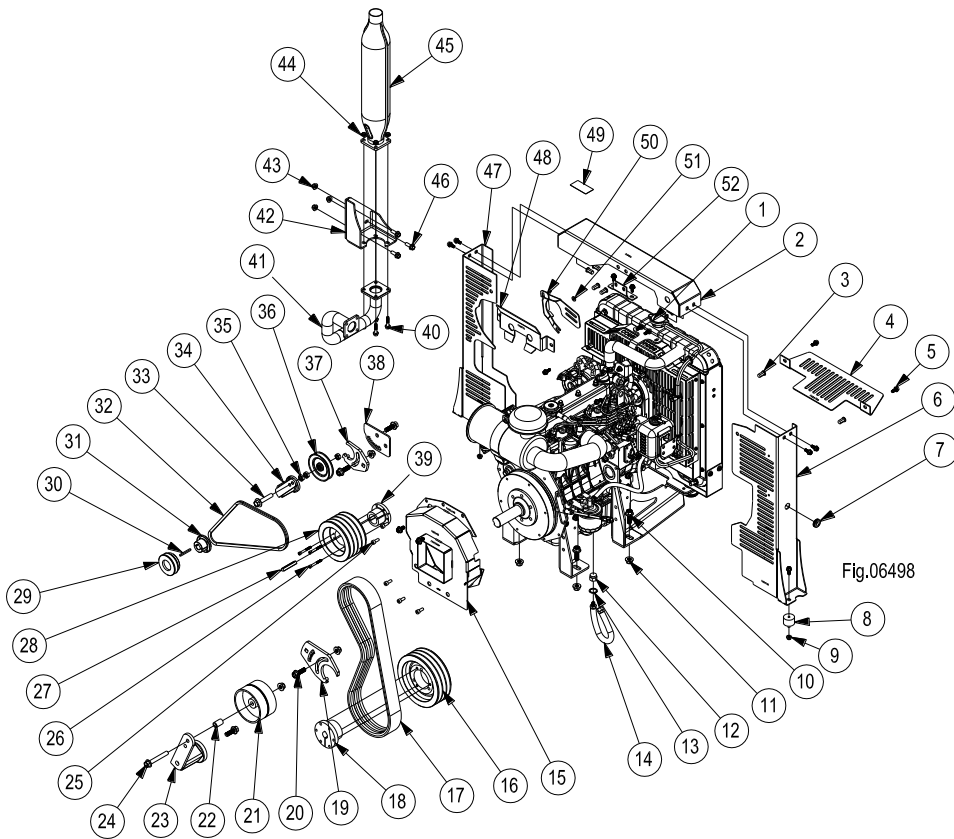

Fig. 06567

PUMP, ENGINE, AND GENERATOR BASE WITH ISO MOUNTS (FIG.06567)

Ref. #	Part #	Description	Qty.
1	798389	Base for the Pump, Engine, and Generator Head	1
2	82628	Bolt, 1/2-13 x 2-1/2" hex head	6
3	82624	Bolt, 3/8-16 x 1" hex head flange, Gr. 5	12
4	795646	Iso Mount Green/Gold 230	6
5	82122	Washer, 1/2" USS	6
6	794460	Washer, Snubbing	6
7	82631	Nut, 3/8-16 hex flange nylon	6
8	82627	Bolt, 1/2-13 x 1-1/2" hex head	6
9	82632	Nut, 1/2-13 nylon flange lock	6
10	793631	Iso Mount for Pump, Engine and Generator Base	2

Parts Explosion (Pump, Engine, & Generator) – REV. E.1



ENGINE/BELTS/PULLEYS (FIG.06498)

Ref.#	Part #	Description	Qty.
1	798392	Engine, 24.7HP Kubota V1505	1
1.1	801474	Harness, Kubota Engine, 18", Sealed Relays (not shown)	1
1.2	801478	Harness, 12-Pin Extension, 9FT. (not shown)	1
1.3	801479	Harness, Magnetic Pickup, 45" (not shown)	1
1.4	801480	Harness, Magnetic Pickup, 108" (not shown)	1
1.5	799023	Filter, Fuel, Kubota V1505	1
1.6	786309	Filter, Oil, Kubota V1505	1
1.7	799025	Filter, Air, Kubota V1505	1
2	798472	Kubota V1505 Belt Guard, top	1
3	82651	Rivet Nut 5/16-18 GR .105	6
4	798478	Plate, Rad. Guard Kubota	1
5	82621	Bolt, 5/16-18 x 3/4" hex head flange	12
6	798473	Left Weldment, Kubota V1505	1
7	787403	Grommet, 5/8 ID SYM- WP	2
8	30825	Mount, 1.0" ISO CR50	2
9	82630	Nut, 5/16-18 nylon insert lock	6
10	82663	Bolt, 1/2-13 x 1-1/2" Gr.8	4
11	82632	Nut, 1/2-13 nylon flange lock	4
12	796323	Adapter, Oil Drain Kubota	1

Parts Explosion (Pump, Engine, & Generator) – REV. E.1

ENGINE/BELTS/PULLEYS (FIG.06498) Continued			
Ref. #	Part #	Description	Qty.
13	796325	Bonded Seal M22	1
14	796339	Oil Drain Kit 3/8 NPT P	2
15	798543	Weldment, V1505 Flywheel	1
16	779526	Sheave, 3BK74SK - PW	1
17	794393	Belt, 3B X 53	1
18	779529	Bushing, SK X 24MM - PW	1
18.1	798589	Bolt with lock washer for Pump bushing	3
19	793855	Pump Tension Adjustment	1
20	82627	Bolt, 1/2-13 x 1-1/2" hex head	4
21	794410	Pulley, Idler 5" Flat	1
22	794021	Pump Idler Pulley Space	1
23	794413	Lovejoy SE-R27 Tensioner	1
24	82474	1/2-13 x 3-1/2" Hex Head Flange Bolt	1
25	82313	Screw, M8 1-1/4 x 20 SHCS	5
26	82706	Bolt, M10x1.5-25MM SHCS	3
27	784049	Key, Shaft 3/8 x 3/8 x 3.75"	1
28	798384	Sheave, 4A4.8B5.2 - SD	1
29	798386	Sheave, AK30H	1
30	82142	3/16 x 2" Shaft Key	1
31	33562	Bushing H-3/4	1
31.1	798590	Bolt with lock washer for Generator bushing	2
32	794398	Belt, A X 39	1
33	82035	Bolt, 1/2-13 x 2-1/2 HHFS GR5Z	1
34	794412	Lovejoy SE-R18 Tensioner	1
35	82653	1/2-13 Prevailing Torque Nut	3
36	794411	Pulley Idler 4" A Grove	1
37	793913	Generator Tension Adjustment Plate	1
38	794020	Generator Tensioner Spacer Plate	1
39	794407	Bushing, SD 1-7/16"	1
40	82622	Bolt, 5/16-18 x 1.5" HH	4
41	798422	V1505 Flex Exhaust	1
42	794919	Bracket, Diesel Muffler	1
43	82631	Nut, 3/8-16 hex flange nylon	4
44	789037	Nut, 5/16-18 hex flange locknut	4
45	NP19077-12110	Muffler	1
45.1	NPT0070-16420	Gasket (not shown)	1
45.2	NP15263-12370	Gasket, Muffler (not shown)	1
45.3	NP16617-12670	Cap, Rain (not shown)	1
46	82624	Bolt, 3/8-16 x 1" hex head flange, Gr. 5	3
47	798475	Weldment, V1505 Engine guard	1
48	798477	Rear bracket, V1505 Belt guard	1
49	786632	Decal, rotating machine warning	1
50	795826	Guard, Kubota Alternator	1

Parts Explosion (Pump, Engine, & Generator) – REV. E.1

ENGINE/BELTS/PULLEYS (FIG.06498) Continued

Ref. #	Part #	Description	Qty.
51	777496	Washer, Flat M8, Zinc	1
-	82045	Bolt, M8-1.25 x 25 Gr8.8Z HHCS (For alternator guard)	1
-	82109	Bolt, 3/8-16 x 3-1/4" Gr5Z HHCS (For alternator guard)	1
-	82290	Nut, 3/8-16 Class G Flange lock (For alternator guard)	1
-	82137	Bolt, M10-1.5 x 16	2
-	82037	Nut, Nylon Insert 1/2-13	1

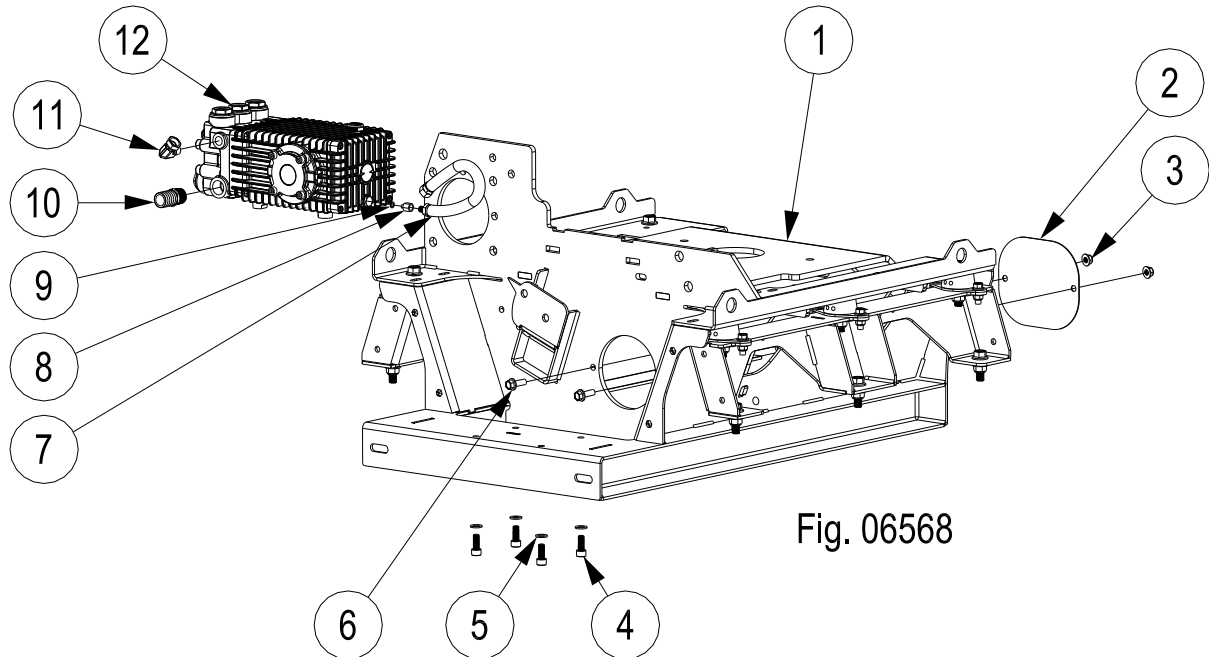
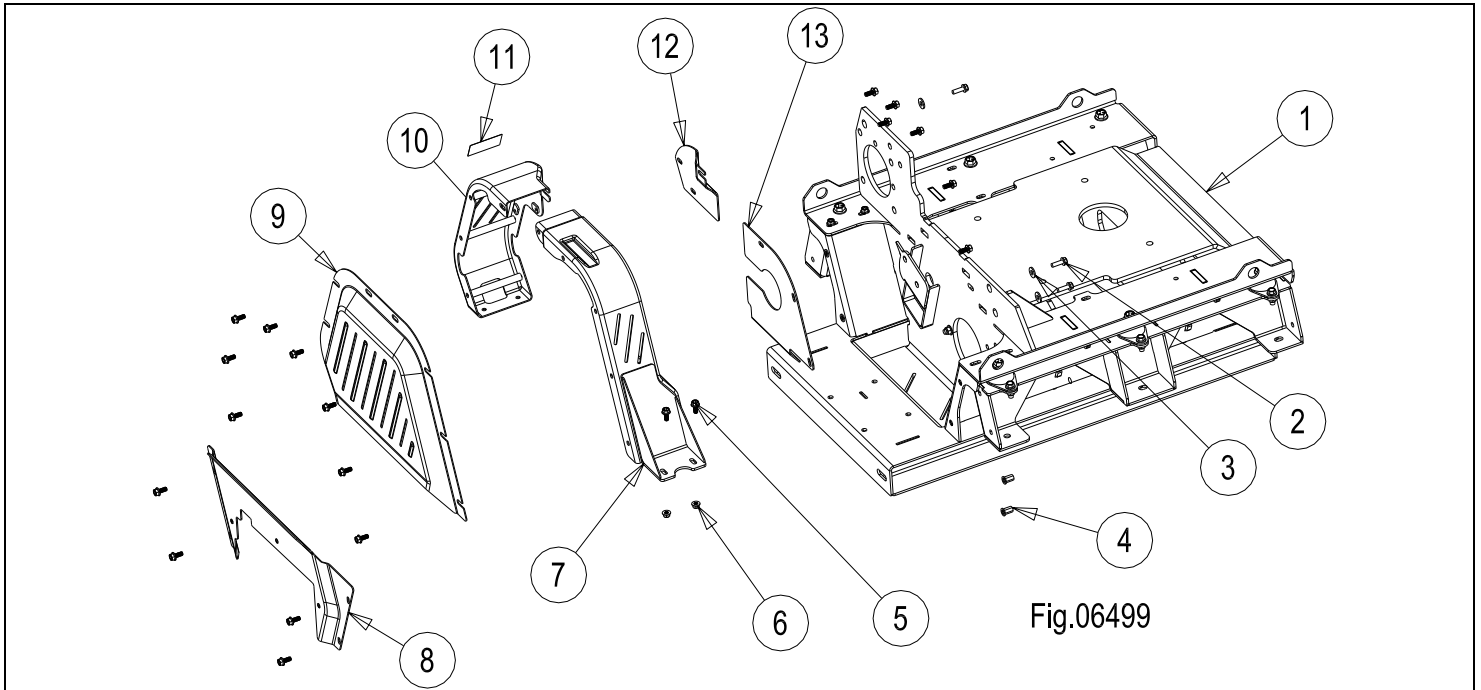

Fig. 06568

PUMP (FIG.06568)

Ref. #	Part #	Description	Qty.
1	798389	Base for the Pump, Engine, and Generator Head	1
2	796082	Patch Plate	1
3	82631	Nut, 3/8-16 hex flange nylon	2
4	82706	Bolt, M10x1.25 – 25mm SHCS	4
5	82201	Washer, M10 Flat	4
6	82624	Bolt, 3/8-16 x 1" hex head flange, Gr. 5	2
7	796339	Drain Hose for Engine Oil	1
8	796320	Oil Drain Adapter	1
9	796326	Bonded Seal 1/4	1
10	794041	Fitting, 3/4" NPT x 1" Hose Barb x 1" Hose Barb, Steel	1
11	797199	Elbow, 3/8 MPT x 3/8 FPT swivel	1
12	794390	GP 8 @ 3000 BD Left Crank (See Parts Explosion Pump)	1

Parts Explosion (Pump, Engine, & Generator) – REV. E.1



BELT GUARD (FIG. 06499)

Ref. #	Part #	Description	Qty.
1	798389	Base for the Pump, Engine, and Generator Head	1
2	82016	Bolt, 5/19-18 x 1" HHSF Gr. 5	3
3	82021	Washer, 5/16" USS	3
4	82650	Rivet Nut 5/16"	4
5	82621	Bolt, 5/16-18 x 3/4" hex head flange	22
6	82630	Nut, 5/16-18 nylon insert lock	4
7	793917	Belt Guard Right Weldment	1
8	794014	Pump Plate	1
9	793985	Belt Guard Front Cover	1
10	793827	Belt Guard Left	1
11	786632	Decal, Rotating Mach	1
12	793968	Belt Guard Patch	1
13	794027	Guard, Kubota plate	1

Parts Explosion (Pump, Engine, & Generator) – REV. E.1

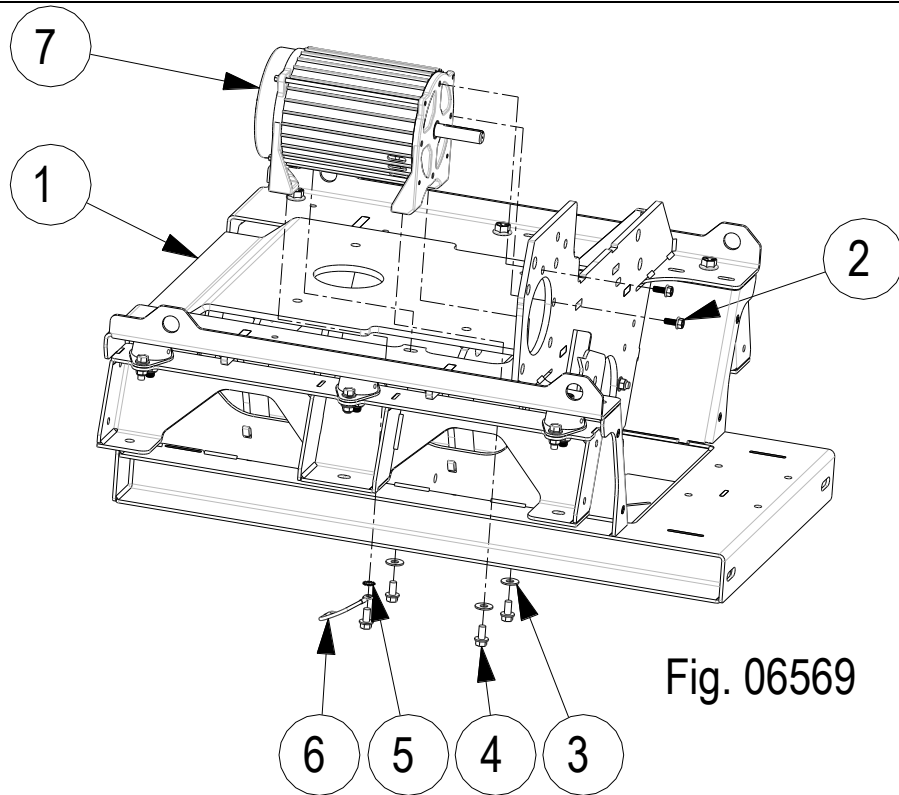

Fig. 06569

GENERATOR HEAD (FIG. 06569)

Ref. #	Part #	Description	Qty.
1	798389	Base for the Pump, Engine, and Generator Head	1
2	82621	Bolt, 5/16-18 x 3/4" hex head flange	2
3	82028	Washer, 3/8" USS flat	3
4	82022	Bolt, 3/8-16 x 3/4" hex head serrated flange	4
5	82465	Washer, External star 3/8"	1
6	306459	Wire, Engine ground wire	1
7	795080	2000W Belt Drive Generator (See Parts Explosion Generator)	1
-	796937	Wire, Engine to Chassis ground	1

Parts Explosion (Skid) (Roll Cage) – REV. E.1

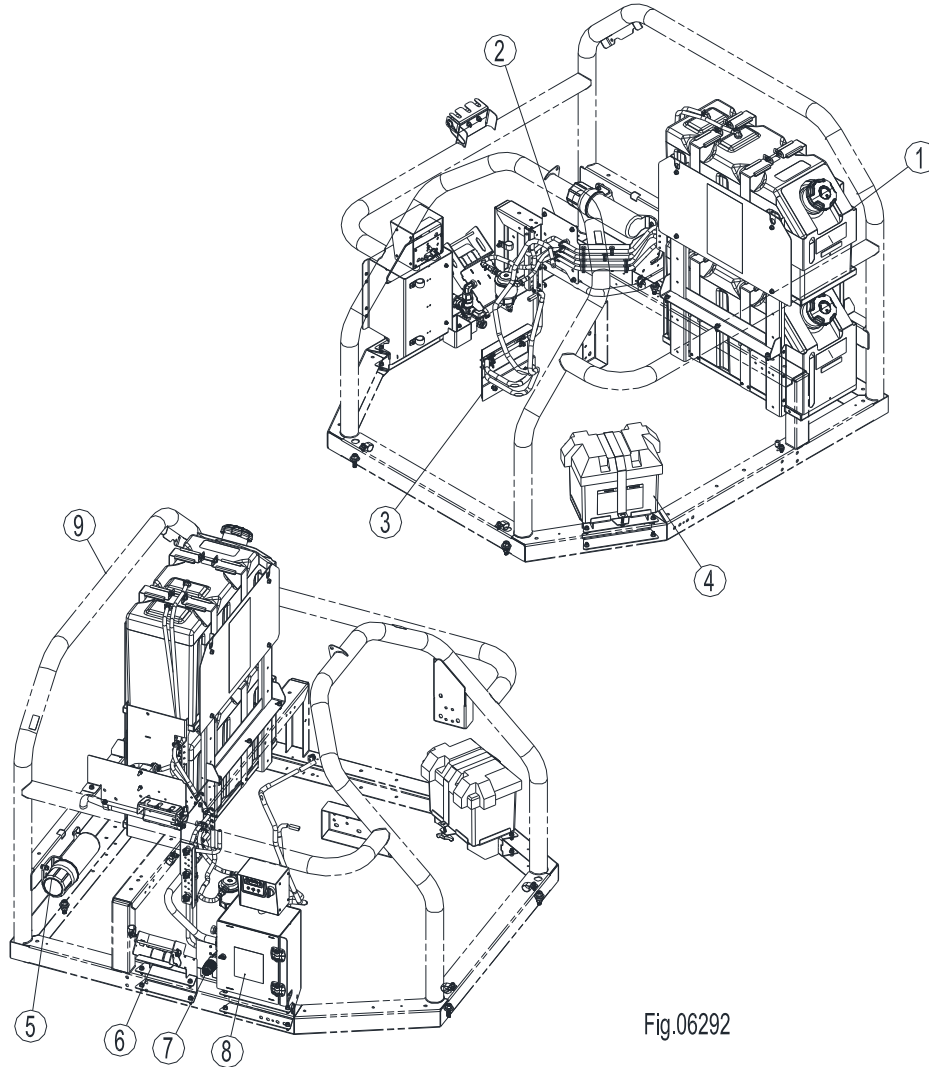

Fig.06292

Skid (Roll Cage) (FIG.06292)

Ref. #	Description	Figure #
1	Fuel Tank Housing	06347
2	Fuel Routing Management System	06346
3	Fuel Line Routing	
	Burner Fuel Line Routing	06268
	Engine Fuel Line Routing	06294
4	Battery Housing	06082
5	Manual Tube	06085
6	Gun Mount	06084
	Spray Gun	06256
7	Unloader	06083
8	Control Box Housing	06438
9	Skid (Roll Cage) Weldment Part #794170	06292

Parts Explosion (Skid) (Roll Cage) – REV. E.1

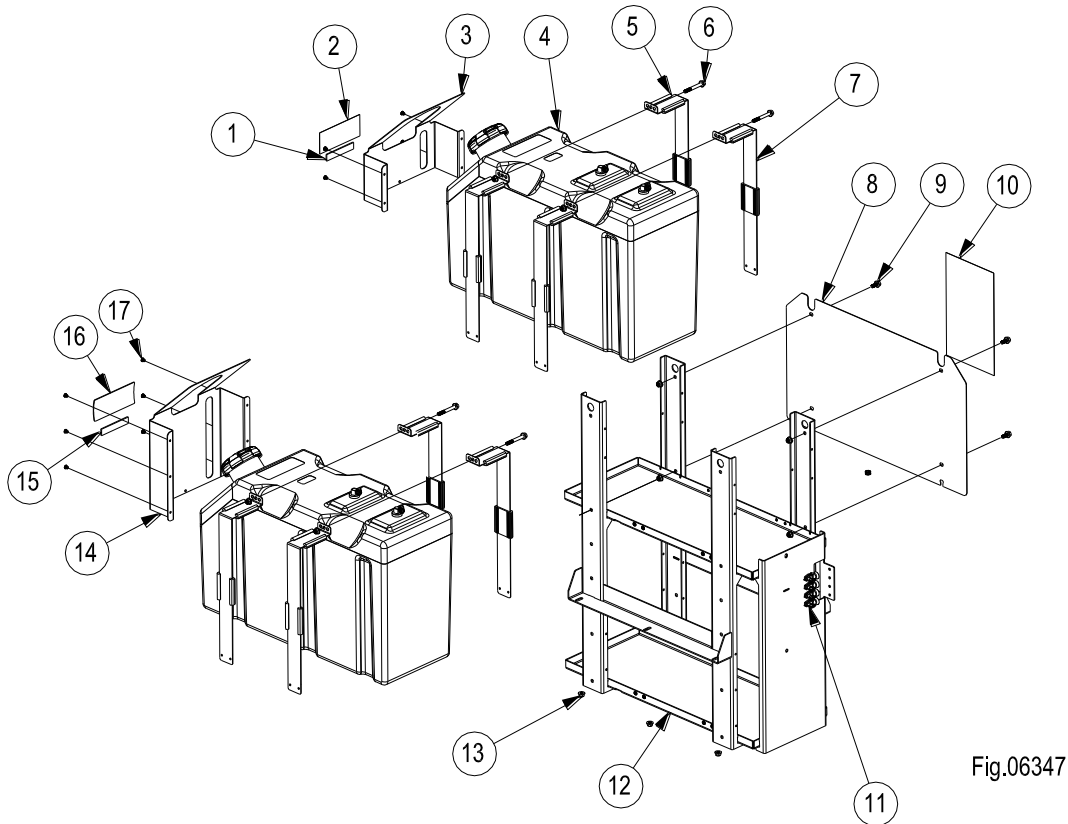

Fig.06347

FUEL TANK HOUSING (FIG.06347)

Ref. #	Part #	Description	Qty.
1	787827	Decal, Diesel, Kerosene or Fuel Oil Only	1
2	796861	Decal, Burner Fuel tank	1
3	796606	Diesel Tank Front Cover	1
4	793217	Burner/Engine Fuel Tank	2
4.1	793225	Burner/Engine Fuel Tank Cap w/Teether	2
5	793643	Tank Strap Protector	16
6	82623	Bolt, 5/16-18 x 2-1/2" hex head flange	4
7	794380	Tank Strap Tension Arm	8
8	794886	Heat Shield	1
9	82621	Bolt, 5/16-18 x 3/4" hex head flange	5
10	782325	Decal, Danger and Warning	1
11	793645	Hose/Wire Clip, 1/2"	4
12	793240	Fuel Tank Tray, 16Gal	1
13	82630	Nut, 5/16-18 nylon insert lock	11
14	796608	Diesel Tank Front Cover	1
15	796862	Decal, Engine Fuel Tank	1
16	785088	Decal, Diesel Only	1
17	82649	Blind Rivet, 3/16"	26
-	82301	Washer, 5/16" external star (not shown)	3

Parts Explosion (Skid) (Roll Cage) – REV. E.1

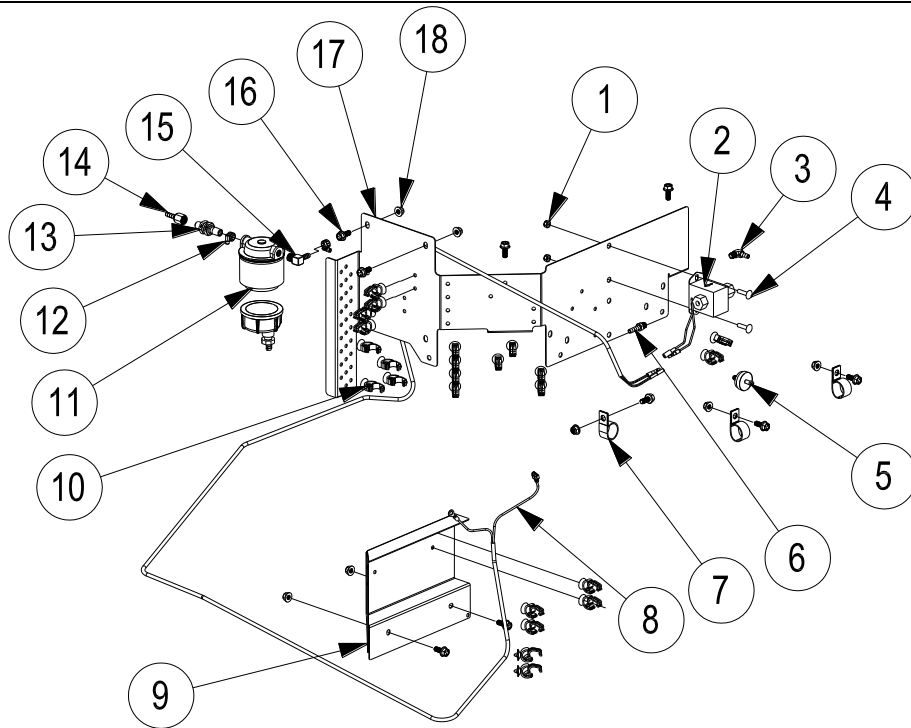
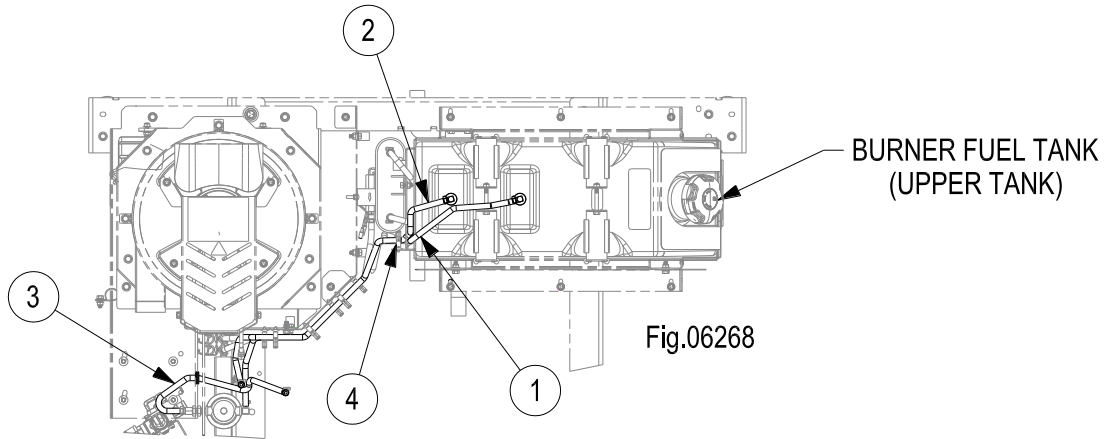

Fig.06346

FUEL ROUTING MANAGEMENT SYSTEM (FIG.06346)

Ref. #	Part #	Description	Qty.
1	82222	Nut, 1/4-20 nylon insert lock	2
2	798575	Fuel Pump, 2-3.5PSI 15GPH	1
2.1	32417	Wire, Snap plug terminal, male	1
2.2	32420	Wire, Snap plug terminal, female	1
3	796161	Elbow, 1/4" x 1/8" hose barb	1
4	82315	Bolt, 1/4 -20 x 1" carriage	2
5	30755	Filter, fuel, red, 150 microns	1
6	796162	Fitting, 1/4" x 1/8" NPT	1
7	779666	Clamp, 1" loop	4
8	796304	Wire harness (Kubota), fuel pump	1
9	793210	Frame rail clip mount	1
10	793645	Hose/Wire Clip, 1/2"	24
11	799864	Filter, Fuel/water separator	1
11.1	RCR12T	Filter element	1
12	777834	Clamp, 1/4" Hose	2
13	795027	Fitting, 1/4" NPT Bulkhead	1
14	796282	Fitting, 1/4" HB x 1/4" FPT	1
15	783212	Elbow, 1/4" MPT x 1/4" HB	1
16	82621	Bolt, 5/16-18 x 3/4" hex head flange	10
17	793206	Fuel hose bracket	1
18	82630	Nut, 5/16-18 nylon insert lock	10

Parts Explosion (Skid) (Roll Cage) – REV. E.1



BURNER FUEL LINE ROUTING (FIG.06268)

Ref. #	Part #	Description	Qty.
1	798361	Hose, 1/4" Fuel Line –Fuel tank to fuel filter/water separator (4.67' long)	1
2	798362	Hose, 1/4" Fuel Line – Fuel pump bypass to fuel tank (4' long)	1
3	798215	Hose, 1/4" Fuel Line – Filter to Fuel Pump Line (1.92' long)	1
4	793645	Hose/Wire Clip, 1/2"	3

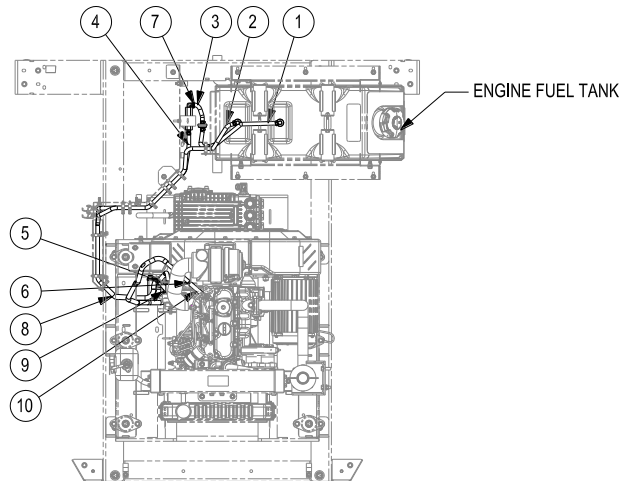

ENGINE FUEL LINE ROUTING (FIG.06294)

Ref. #	Part #	Description	Qty.
1	798430	Hose, 1/4" Fuel Line – Supply Line From Fuel Filter To Tank (1.43' long)	1
2	798431	Hose, 1/4" Fuel Line – Return Line From Engine To Fuel Tank (6.58' long)	1
3	798216	Hose, 1/4" Fuel Line – Fuel Pump to Fuel Filter (.32' long)	2
4	798363	Hose, 1/4" Fuel Line - Supply Line from fuel pump to Engine (5.33' long)	1
5	796689	Hose Mender, 1/4" x 5/16" Nylon	1
6	785767	Hose Mender, 1/4" x 3/16" Nylon	1
7	777834	Clamp, 1/4" Hose	8
8	31881	Reflective tape (2' long)	2
9	798636	Hose, 5/16" fuel line (.333' long)	1
10	798637	Hose, 3/16" fuel line (.333' long)	1

Parts Explosion (Skid) (Roll Cage) – REV. E.1

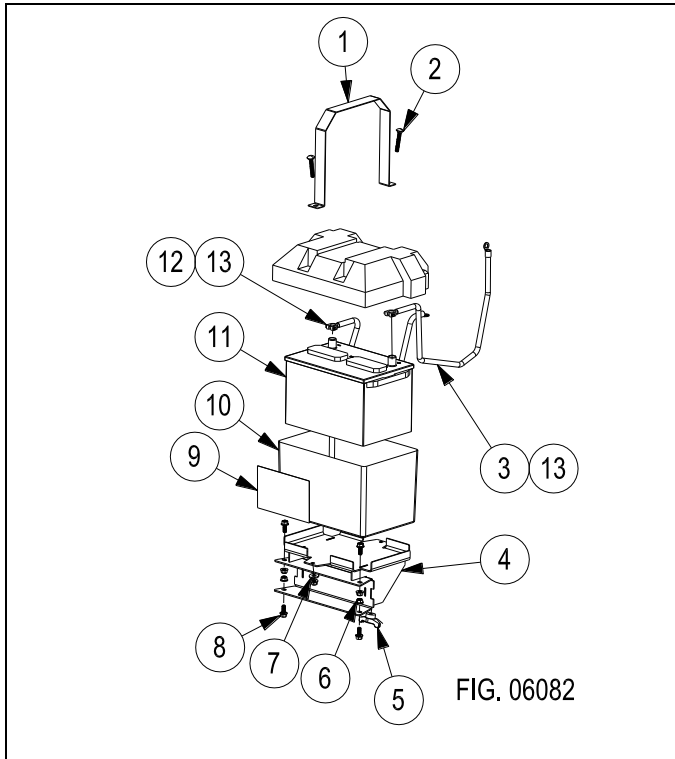

BATTERY HOUSING (FIG.06082)			
<u>Ref. #</u>	<u>Part #</u>	<u>Description</u>	<u>Qty.</u>
1	777489	Battery Strap	1
2	82233	Bolt, 5/16-18 x 2" carriage	2
3	16707	36" Red Battery Cable	1
3.1	797097	Nut, 3/8" Battery Lug Wing (not shown)	1
4	794449	Battery Box Tray Weldment	1
5	38578	T-Handle Knob	1
6	82630	Nut, 5/16-18 nylon insert lock	5
7	82021	Washer, 5/16" USS	2
8	82621	Bolt, 5/16-18 x 3/4" hex head flange	4
9	782397	Decal, Battery Warning	1
10	777647	Standard Battery Box with lid	1
11	799018	Top Post Battery	1
12	796622	Cable, Battery Black w/Top Post Terminal	1
13	777135	Split loom, 3/8" on battery cables 18" each (Not Shown)	2

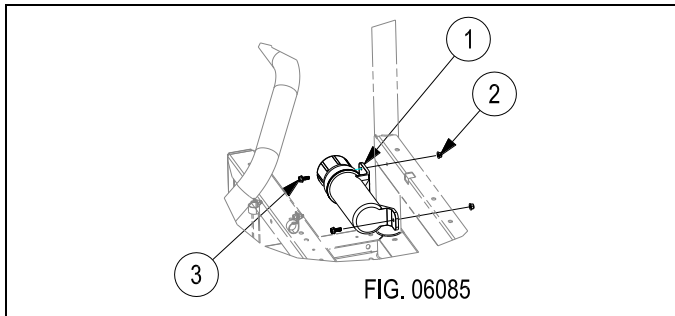

MANUAL TUBE (FIG.06085)			
<u>Ref. #</u>	<u>Part #</u>	<u>Description</u>	<u>Qty.</u>
1	788040	Manual Tube	1
2	82630	Nut, 5/16-18 nylon insert lock	2
3	82621	Bolt, 5/16-18 x 3/4" hex head flange	2

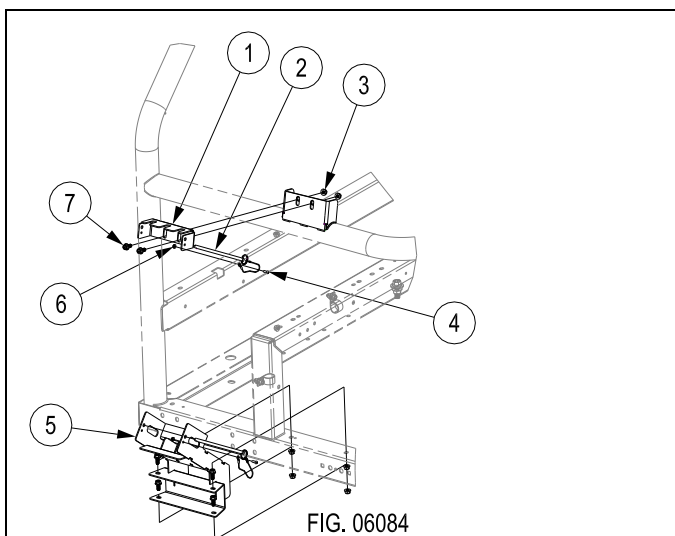

SPRAY GUN MOUNT (FIG.06084)			
<u>Ref. #</u>	<u>Part #</u>	<u>Description</u>	<u>Qty.</u>
1	796940	Upper gun mount (Lance Rest)	1
2	797021	Detent pin with lanyard	2
3	82630	Nut, 5/16-18 nylon insert lock	6
4	82059	10-24 x 1/2" Phillips Head Screw	2
5	796612	Lower gun mount	1
6	82065	Nut, #10-24 nylon insert lock	2
7	82621	Bolt, 5/16-18 x 3/4" hex head flange	6

Parts Explosion (Skid) (Roll Cage) – REV. E.1

SPRAY GUNS (FIG.06077)			
Ref. #	Part #	Description	Qty.
1	791279	Lance, 28" Viton Coupler	2
1.1	796379	O-Ring (not shown)	2
1.2	791274	1/4" Coupler with O-Ring (not shown)	2
2	796731	Gun with Lance	2
2.1	GP2701015	O-Ring (not shown)	2
2.2	GP2701024	O-Ring (not shown)	4
2.3	GP2710004	O-Ring (not shown)	2
3	796634	Gun Swivel	2
4	780455	Fitting, 3/8" quick connect x 3/8" MPT	2
4.1	GP2701020	O-Ring (not shown)	2
5	797590	Hose, 3/8" x 50' High Pressure	2
6	777915	Nipple, 3/8"	2
7	777914	Coupling, 3/8"	2
7.1	GP2701020	O-Ring (not shown)	2

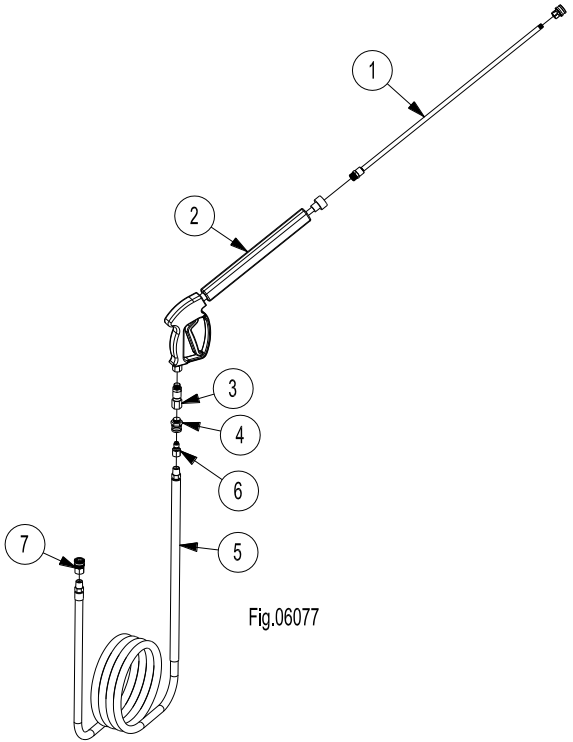

Fig.06077

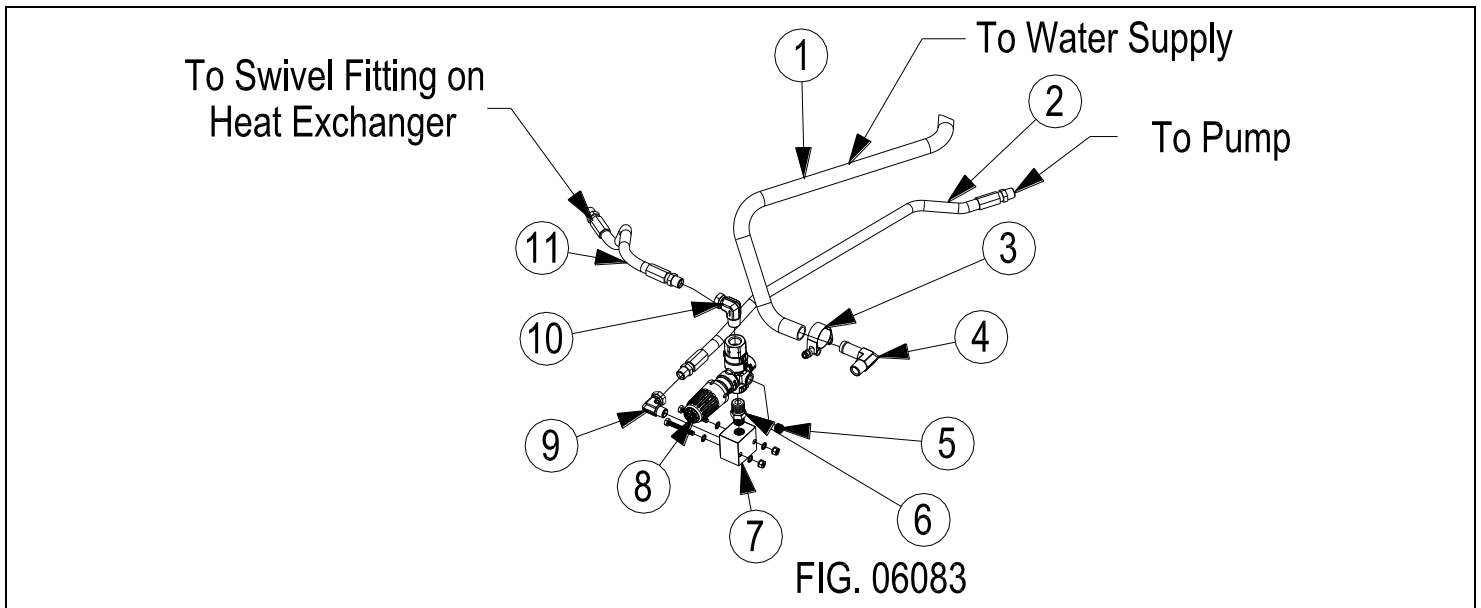

FIG. 06083

UNLOADER (FIG.06083)			
Ref. #	Part #	Description	Qty.
1	798351	Hose, 3/4" x 8'	1
2	798264	Hose, 3/8" X 31"	1
3	796618	Clamp, T-bolt 1.06" - 1.14" OD	1
4	796160	Elbow, 1/2" MPT X 3/4" beaded	1
5	777838	Plug, hex 1/4" counter sunk	1

Parts Explosion (Skid) (Roll Cage) – REV. E.1

UNLOADER (FIG.06083) Cont'd.

Ref. #	Part #	Description	Qty.
6	777337	Nipple, hex 8MP-6MP	1
7	777409	Unloader block mount with bolts & nuts	1
8	796502	Unloader valve	1
9	797201	Elbow, 3/8" MPT x 3/8" FPT swivel	1
10	797203	Elbow, 1/2" MPT x 3/8" FPT swivel	1
11	777378	Hose, 3/8 x 18" - Connects to Part # 797199 in heat exchanger parts explosion	1

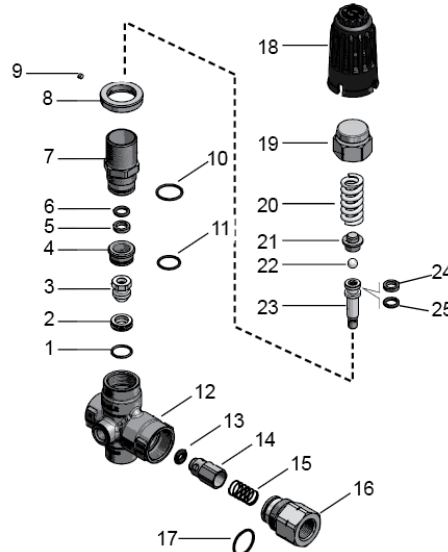

UNLOADER PARTS LIST (PART #796502)

Ref. #	Part #	Description	Qty.
1	GPY10306601	O-Ring, 1.78x15.6	1
2	GPY60180951	Seat, 11.6x19x6, SST	1
3	GPY60180851	Shutter Pin, M8, SST	1
4	GPY60182231	Spacer Ring, Brass	1
5	GPY10401075	Stem Seal	1
6	GPY10317175	O-Ring	1
7	GPY60182331	Piston Holder, Brass	1
8	GPY60172831	Ring Nut, M27x1, Brass	1
9	GPY16210000	Screw, M4x4, set	1
10	GPY10307201	O-Ring, 1.78x20.35	1
11	GPY10306801	O-Ring, 1.75x17.17	1
12	GPY60185135	Brass body, 1/2" NPT	1
13	GPY10329285	O-ring	1
14	GPY60048831	Shutter pin, brass + O-ring	1
15	GPY60048951	Spring, 0.8x13.3x27, SST	1
16	GPY60185231	Shutter coupling, 1/2" f, NPT, brass	1
17	GPY10307260	O-Ring, 1.78x21.95	1
18	GPY60172684	Valve regulating knob	1
19	GPY60172731	Valve regulating insert, brass	1

Parts Explosion (Skid) (Roll Cage) – REV. E.1

UNLOADER PARTS LIST (PART #796502) Continued

Ref. #	Part #	Description	Qty.
20	GPY60097561	Spring, 4.5x15.8x47	1
21	GPY60181331	Spring rest pin, brass	1
22	GPY14744310	Ball, 11/32", SST	1
23	GPY60182151	Piston, M8, SST	1
24	GPY10400875	Piston seal	1
25	GPY10317175	O-ring	1
-	GPYKIT4021HT	Repair kit, Ref# 1, 2, 3, 5, 6, 10, 11, 13, 17, 24, 25	1

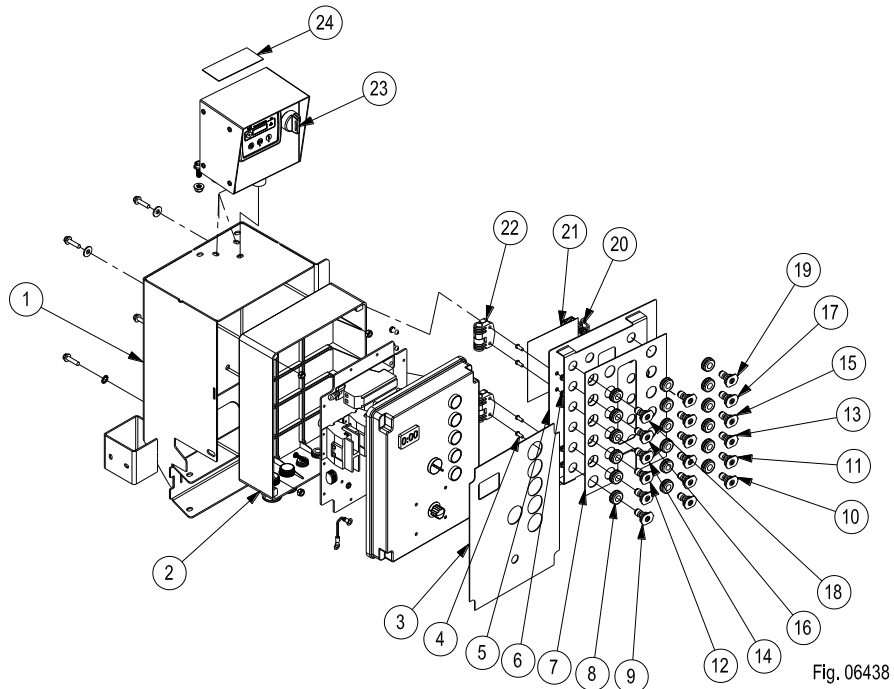

CONTROL BOX (FIG.06438)

Ref. #	Part #	Description	Qty.
1	799609	Control Box Mount Weldment	1
2	794861	Control Box, gas assembly without Decal	1
2.1	82010	Bolt, 1/4-20 x 1"	4
2.2	82085	Washer, 1/4" flat	3
2.3	82222	Nut, 1/4-20 nylon insert lock	4
2.4	82301	Washer, 1/4" star	1
3	797448	Decal, Control Box, Operating Instructions	1
4	82059	10-24 x 1/2" Phillips Head Screw	8
5	796737	Control Box Mount Panel Door	1
6	82065	10-24 Nylon Insert Lock Nut	8
7	797449	Decal, Nozzle Holder	1
8	777111	Grommet	18
9	799396	Nozzle, #3.0 (Steam)	2

Parts Explosion (Skid) (Roll Cage) – REV. E.1

CONTROL BOX (FIG.06438) Continued

Ref. #	Part #	Description	Qty.
10	799395	Nozzle, #7.0 (Steam)	1
11	778949	Nozzle, Soap	3
12	778737	#4.5 - 40Deg (White) 1/4" Quick Connect Stainless Steel Nozzle	2
13	798914	#9.0 - 40Deg (White) 1/4" Quick Connect Stainless Steel Nozzle	1
14	777844	#4.5 - 25Deg (Green) 1/4" Quick Connect Stainless Steel Nozzle	2
15	798913	#9.0 - 25Deg (Green) 1/4" Quick Connect Stainless Steel Nozzle	1
16	782120	#4.5 - 15Deg (Yellow) 1/4" Quick Connect Stainless Steel Nozzle	2
17	798912	#9.0 - 15Deg (Yellow) 1/4" Quick Connect Stainless Steel Nozzle	1
18	782122	#4.5 - 0Deg (Red) 1/4" Quick Connect Stainless Steel Nozzle	2
19	798911	#9.0 - 0Deg (Red) 1/4" Quick Connect Stainless Steel Nozzle	1
20	796536	Control Panel Door Latch	1
21	797447	Decal, Control Box Door	1
22	777201	Detent Hinge	2
23	NPCT00050	Controller, 3110, MPU	1
23.1	NP08482802	On-Off Key Switch, 20A, 12V w/ (2) Keys	1
24	799556	Decal, Warning Prop 65	1

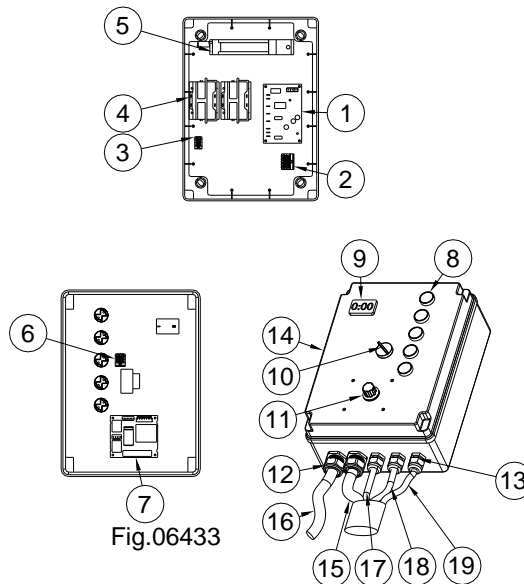

CONTROL BOX ASSEMBLY (FIG.06433)

Ref.#	Part#	Description	Qty.
1	793568	Primary control board	1
2	797045	5 position lever lock	1
3	797047	2 position lever lock	1
4	797049	Relay switch	2
5	799549	Ground fault circuit breaker	1
6	797046	3 position lever lock	1
7	791661	Thermostat board	1
8	797044	Led indicator light	5
9	797050	Hour meter	1
10	797051	Heat switch	1

Parts Explosion (Skid) (Roll Cage) – REV. E.1

CONTROL BOX ASSEMBLY (FIG.06433) Continued

11	797052	Thermostat knob	1
12	797511	Strain relief 3/4"	2
13	22502	Strain relief 1/2"	3
14	798670	Control Box enclosure	1
15	798687	Wire harness, Motor & ignitor cable	1
16	797411	Wire harness, Generator Control wire harness	1
17	798686	Wire harness, Thermistor & high psi limit	1
18	798689	Wire harness, Flow switch cable	1
19	798688	Wire harness, Flame sensor & fuel solenoid	1

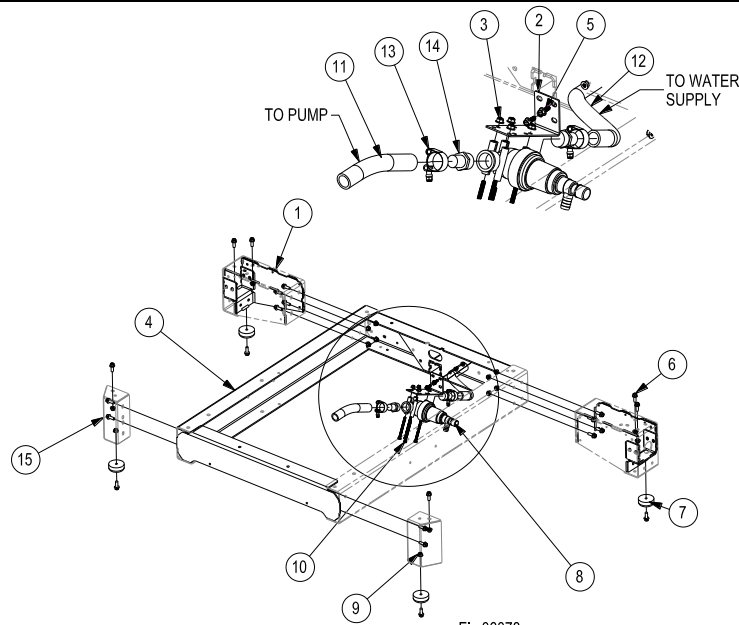

Fig.06078

SKID FRAME (FIG.06078)

Ref. #	Part #	Description	Qty.
1	794237	Foot/Hose Reel Mount Weldment	2
2	795818	Inlet Filter Mount Bracket (Skid)	1
3	82630	Nut, 5/16-18 nylon insert lock	6
4	794144	Skid Ladder Frame Weldment, 60	1
5	82621	Bolt, 5/16-18 x 3/4" hex head flange	2
6	82624	Bolt, 3/8-16 x 1" hex head flange, Gr. 5	22
7	15431	Bumper, Large Shock (2-1/2)	4
8	795301	Inlet Filter	1
9	82631	Nut, 3/8-16 hex flange nylon	22
10	82096	Bolt, 5/16-18 x 3-1/2"	4
11	798641	Hose, 1" x .833' PVC Suction	1
12	798209	Hose, 1" X 4' PVC Suction	1
13	796619	Clamp, 1.34"-1.46" OD	3
14	779496	Fitting, 1" MPT x 1" hose barb nylon	2
15	793010	Front Foot, Skid	2

Parts Explosion (Skid) (Roll Cage) – REV. E.1

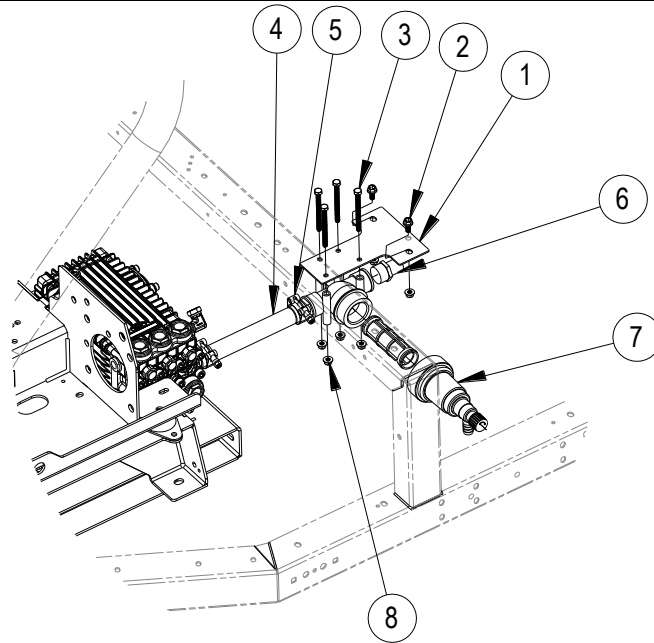
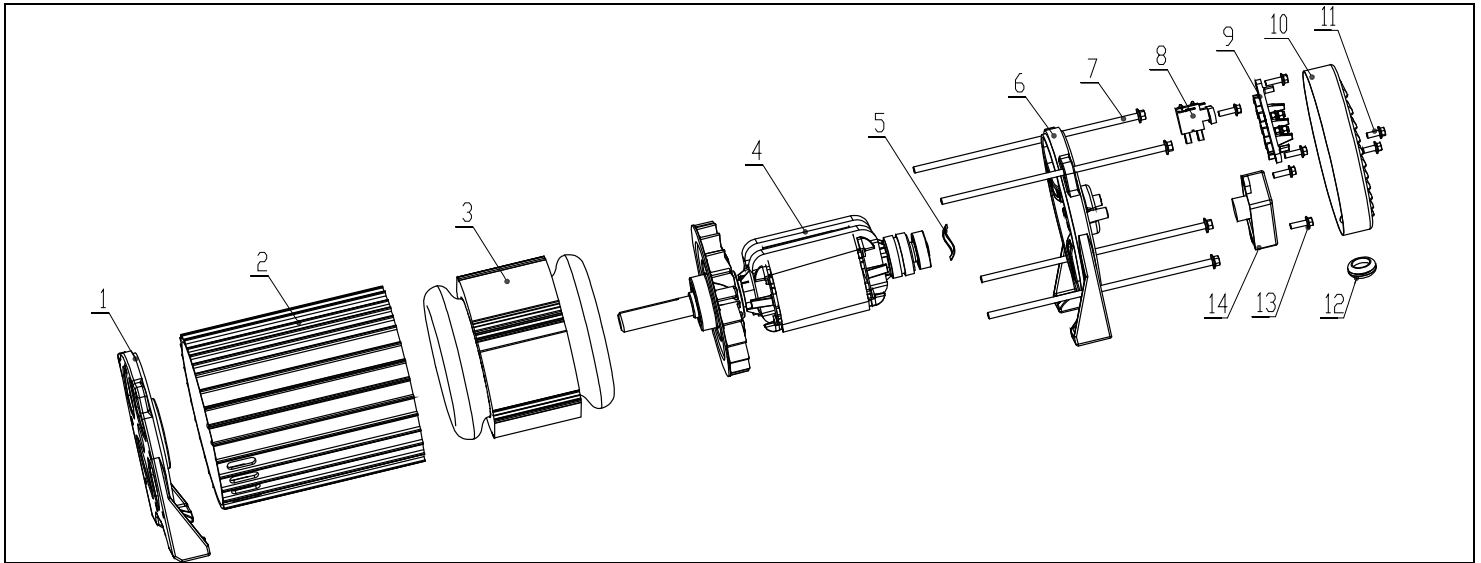

Fig.06281

INLET FILTER (FIG.06281)

Ref. #	Part #	Description	Qty.
1	795818	Inlet filter mounting bracket	1
2	82621	Bolt, 5/16-18 x 3/4" hex head flange	2
3	82096	Bolt, 5/16-18 x 3-1/2"	4
4	798641	Hose, 1" x .833'	1
5	796619	Clamp, 1.34"-1.46" OD	2
6	779496	Fitting, 1" MPT x 1" hose barb nylon	2
7	795301	Inlet filter	1
7.1	798263	50 mesh filter screen	1
8	82630	Nut, 5/16-18 nylon insert lock	6

Parts Explosion (Generator Head) – REV. E.1



GENERATOR HEAD (PART #795080)

<u>Ref. #</u>	<u>Part #</u>	<u>Description</u>	<u>Qty.</u>
1	N/A	Front Cover	1
2	N/A	Brand Cover	1
3	N/A	Stator Assembly	1
4	N/A	Rotor Assembly	1
5	N/A	Washer	2
6	N/A	Rear Cover	1
7	N/A	Bolt, M6 x 8" HF	4
8	796000	Carbon Brush	1
9	798210	Terminal Block	1
10	798211	End Cover	1
11	82681	Bolt, M5-.05 x 50 HF	2
12	798212	Rubber Boot	1
13	N/A	Bolt, M8 x 5/8" HF	5
14	795997	AVR	1

Parts Explosion (Pump) – REV. E.1

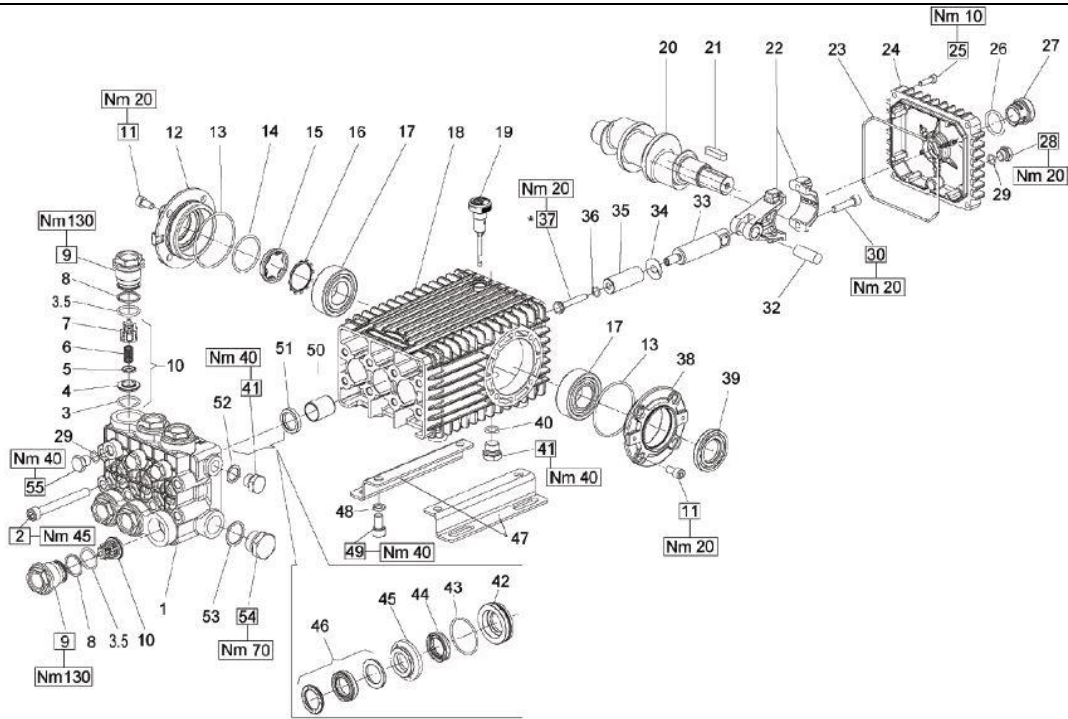

GP TSF2219 PUMP (PART #794390)

Ref. #	Part #	Description	Kit No.	Qty.
1	GP66120141	Manifold, Ø22mm		1
2	GP99380100	Head bolt M10 x 90		8
3	GP90385700	O-ring, Ø23.81 x 2.62	169	6
4	GP36203366	Valve Seat	169	6
5	GP36203476	Valve Poppet	169	6
6	GP94738800	Valve Spring Ø10x18x18.5	169	6
7	GP36203551	Valve Guide	169	6
8	GP90516500	Anti-ext ring Ø24.7x29x1.5		6
9	GP66130041	Plug, M32x1.5x29.5		6
10	GP36712701	Valve Assy., Complete	169	6
11	GP99303900	Screw, M8 x 16		8
12	GP47151222	Cover		1
13	GP701147	O-ring, Ø67.95x 2.62		2
14	GP90387700	O-ring, Ø39.34x 2.62		1
15	GP70211801	Oil Sight Glass		1
16	GP90075600	Retainer Clip		1
17	GP91838000	Bearing		2
18	GP66010022	Crankcase		1
19	GP98210600	Dipstick, vented		1
20	GP66020035	Crankshaft, 19mm Stroke		1
21	GP91489200	Key, 9x7x35		1
22	GP66030001	Connecting Rod, Complete		3
23	GP90392200	O-ring, Ø133.02x 2.62		1
24	GP66160022	Rear Cover		1
25	GP99188400	Screw, M6x20		4
26	GP90405100	O-ring, 26.58x3.53		1

Parts Explosion (Pump) – REV. E.1

GP TSF2219 PUMP (PART #794390) Cont'd.

Ref. #	Part #	Description	Kit No.	Qty.
27	GP63210051	Oil Level Indicator		1
28	GP98204100	Plug, G1/4"x9		1
29	GP701013	O-Ring, Ø.426 x .070		4
30	GP99309900	Screw, M8 x 35		6
32	GP97740500	Wrist Pin, 14x39		3
33	GP66050064	Piston Guide		3
34	GP96710100	Flinger Washer		3
35	GP66040109	Plunger, Ø22mm		3
36	GP90358400	O-ring, Ø10.82 x 1.78		3
37	GP66219566	Plunger Bolt		3
38	GP47151022	Side Cover, PTO		1
39	GP90164800	Seal, Shaft	3	1
40	GP90383300	O-ring, Ø13.95 x 2.62		1
41	GP98210000	Plug 3/8 x 13		2
42	GP66080170	Seal Retainer, Ø22mm	173	3
43	GP90361600	O-ring, Ø34.65 x 1.78	173	3
44	GP90271500	LP Seal, Ø22mm	172, 173	3
45	GP66216170	Intermediate Ring, Ø22mm	173	3
46	GP90271700	HP Seal, Ø22mm	172, 173	3
47	GP47200074	Pump Rail		2
48	GP96710600	Washer M10		4
49	GP99364400	Screw, M10 x 18		4
50	GP90912600	Guide Bushing		3
51	GP90162500	Seal, Plunger Rod	2	3
52	GP96738000	Gasket, Aluminum 3/8"		1
53	GP96770000	Washer		1
54	GP98226800	Plug, G3/4"x16		1
55	GP98204300	Plug 1/4" x 13		3

REPAIR KITS

Kit No.	GPK2	GPK3	GPK169	GPK172 (22mm)	GPK173 (22mm)
Item No's Included in Kit	51	39	3, 4, 5, 6, 7 (10)	44, 46	42, 43, 44, 45 & 46
Number of Assemblies in Kit	3	1	6	3	1
Number of Cylinders Kit will Service	3	N/A	3	3	1

TORQUE SPECS.

POS.	Ft-lb (Decrease Torque by 20% if threads are lubricated)	Nm
2	33.2	45
9	95.9	130
11	14.8	20
25	7.4	10
28	14.8	20
30	14.8	20
37	14.8	20
41	29.5	40
49	29.5	40
54	51.6	70
55	29.5	40

Schematic Drawing

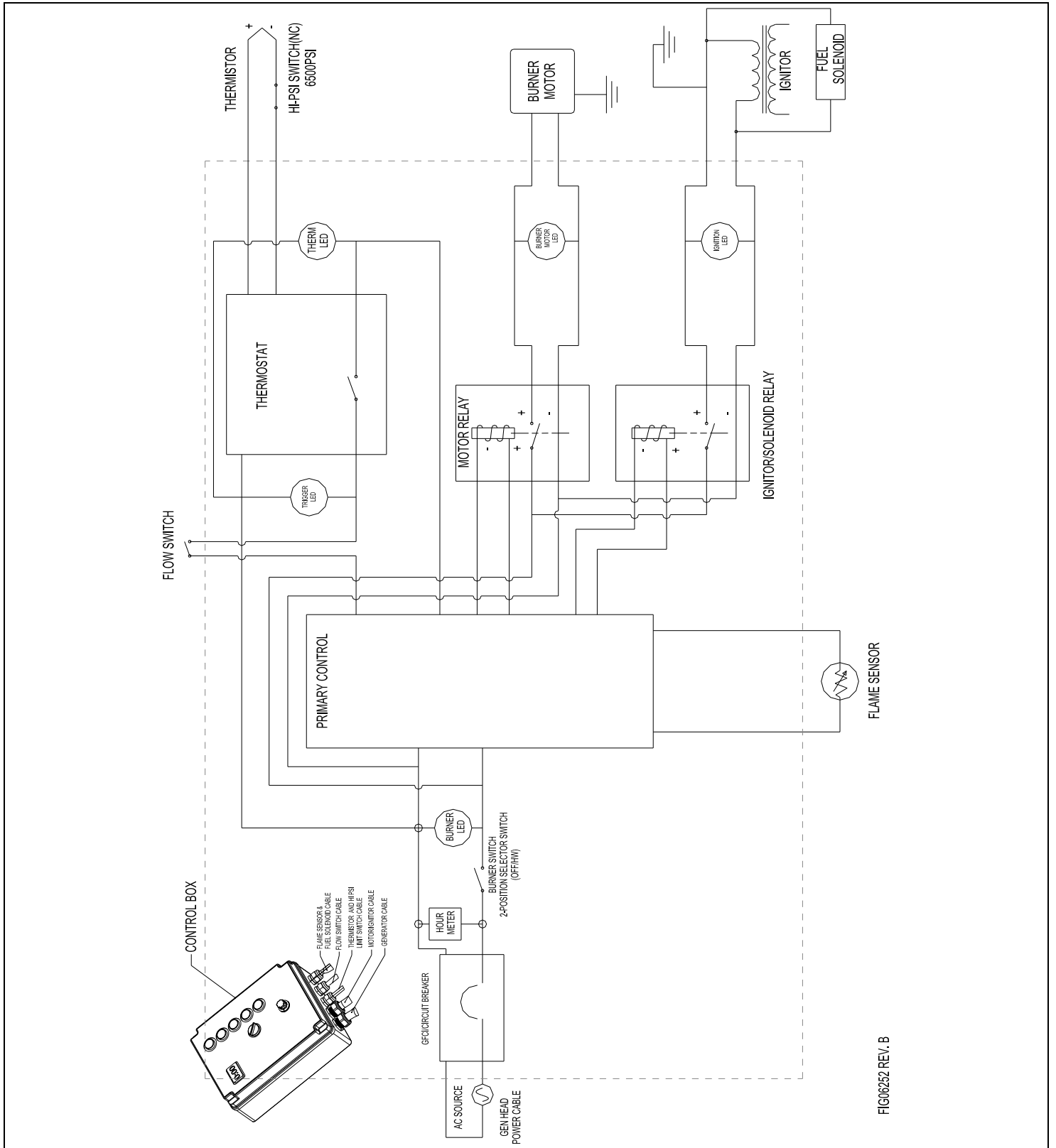
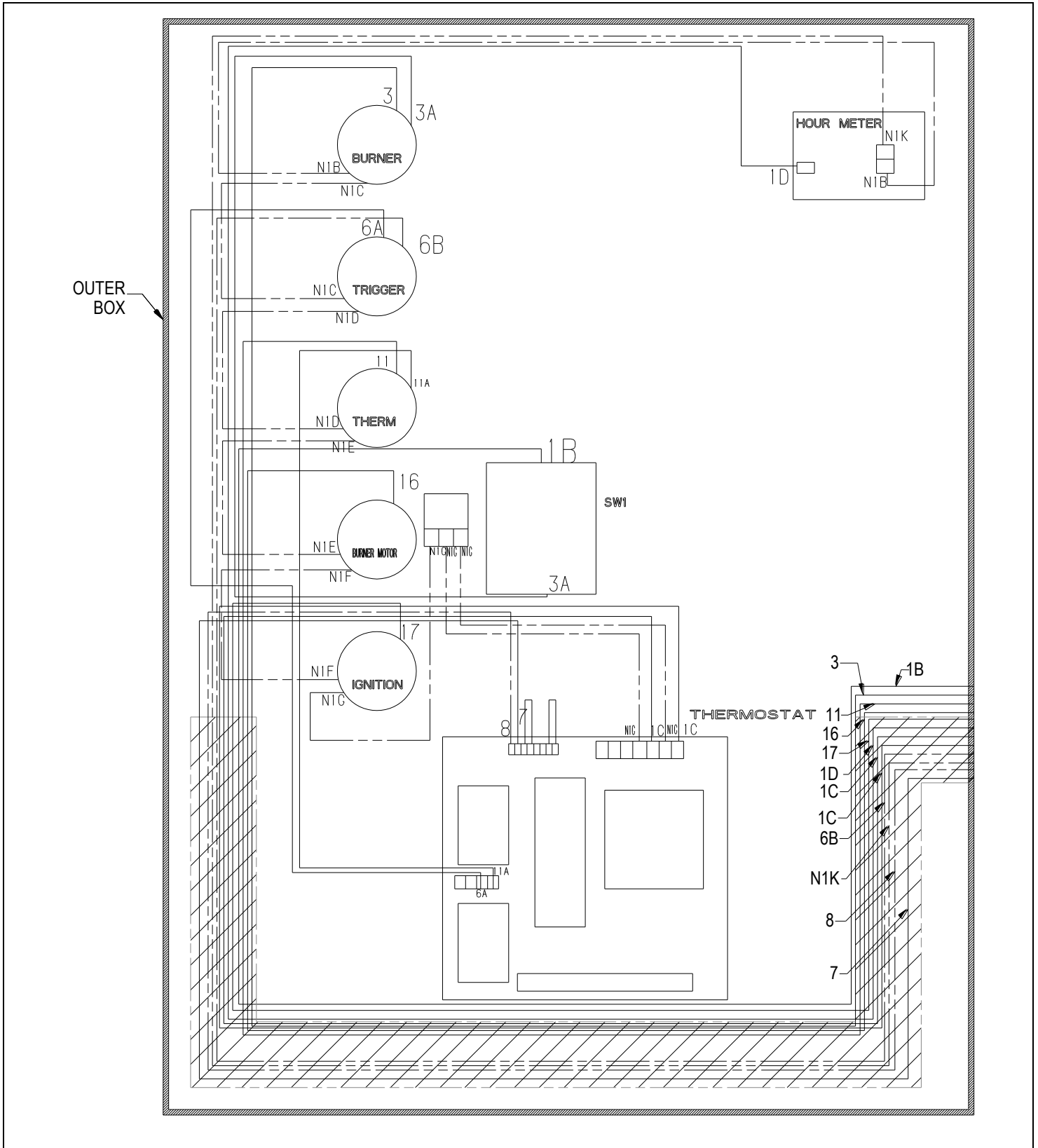
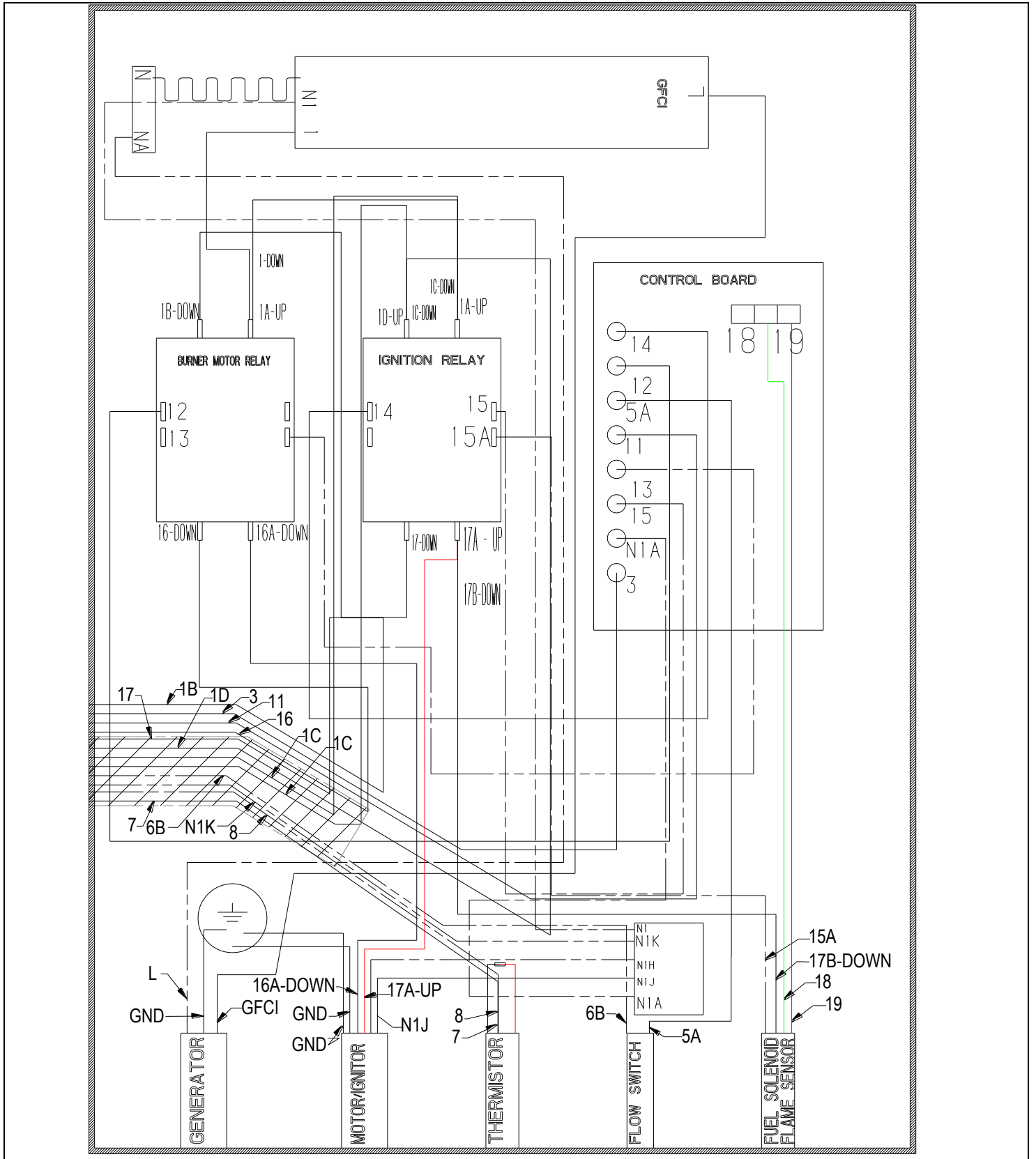

FIG06252 REV. B

Schematic Drawing



Schematic Drawing



Schematic Drawing

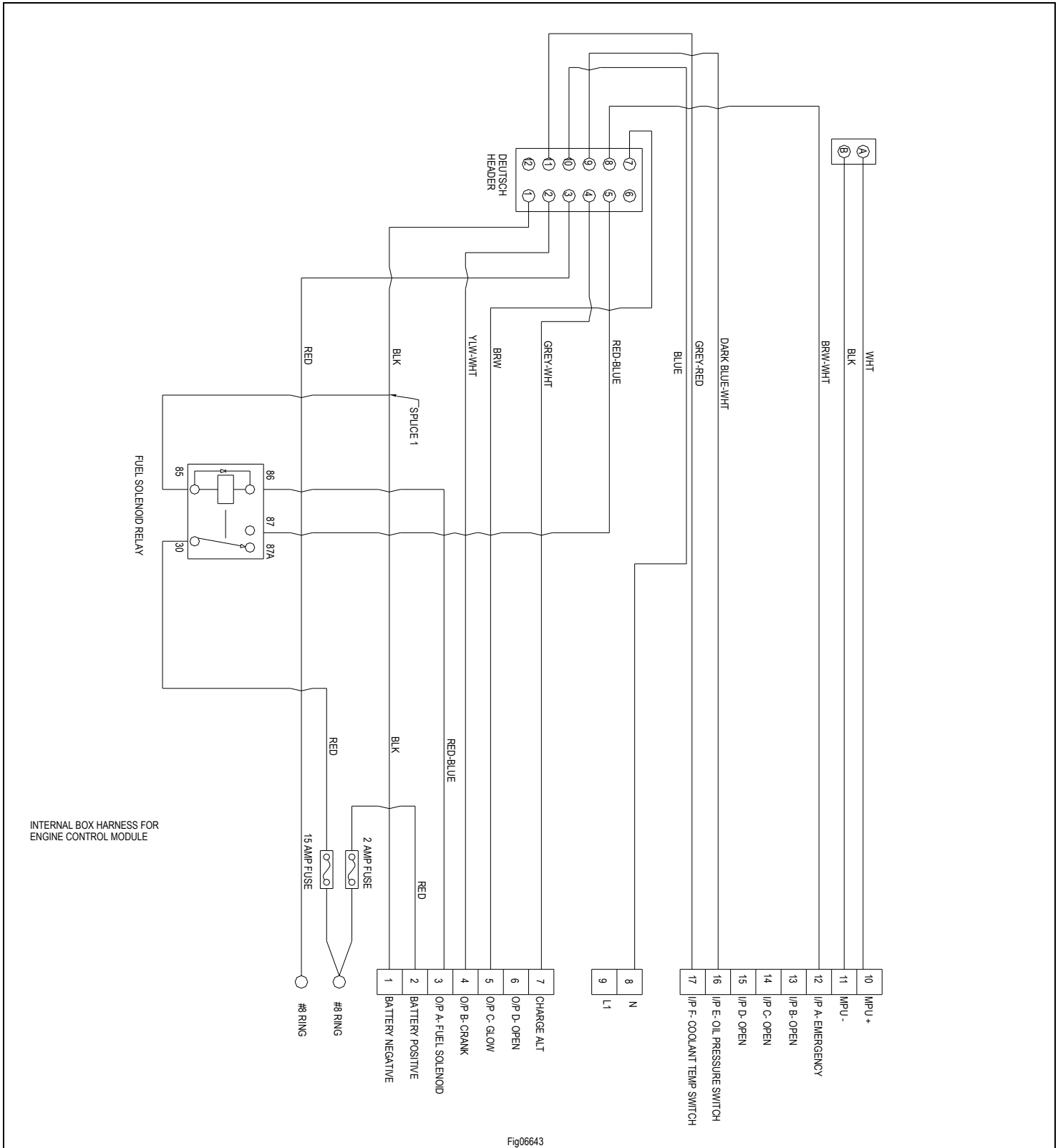
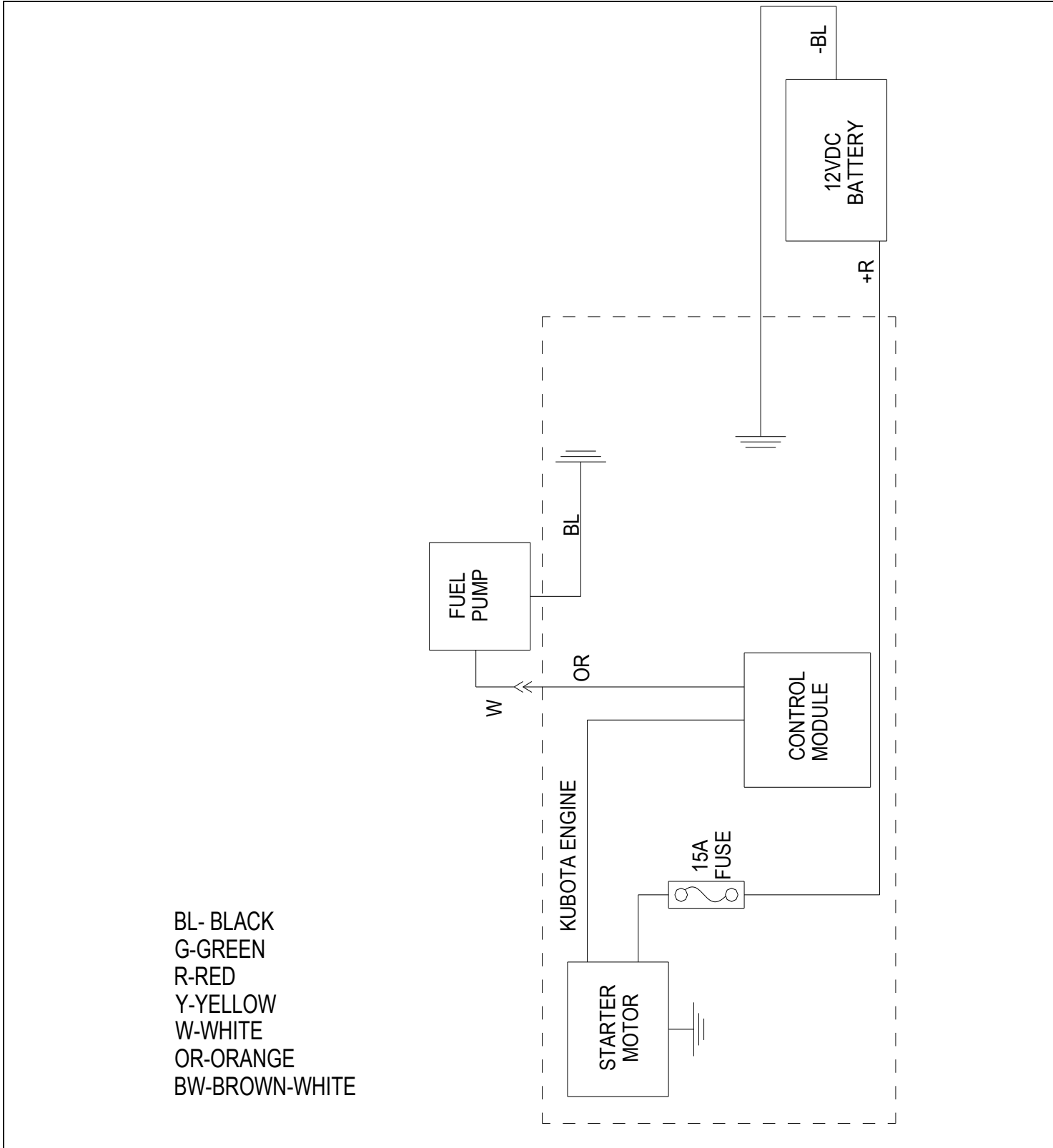

Fig06643

Schematic Drawing



Summary of Important Safety Information

This section provides a summary of the various safety procedures and measures that have been presented throughout the manual. Keep this summary handy and refer to it to refresh your memory about how to safely use your pressure washer.

⚠ DANGER

Carefully read and follow all instructions and safety information for using this pressure washer. Improper use or maintenance of the pressure washer can result in *serious injury or death* to the operator or bystanders from:

- **Carbon monoxide poisoning**
- **Fire/explosion**
- **Chemical exposure**
- **Skin/eye injury from high pressure spray**
- **Burns**
- **Slips/falls**
- **Electric shock**
- **Flying objects/debris**

GENERAL

- **Read all instructions.** Read and understand this owner's manual and the engine Owner's Manual completely before attempting to set-up and use the pressure washer. Serious injury or death can result if safety and other instructions are not followed.
- **Instruct all operators.** The pressure washer's owner must instruct all operators and potential renters in safe pressure washer set-up and operation. Do not allow anyone to operate the pressure washer who has not read the Owner's Manual and been instructed on its safe use. Owner's Manuals are available from North Star at 1-800-969-7073.
- **Adult control only.** Only trained adults should set up and operate the pressure washer. Do not let children operate. Pressure washers can generate forces greater than children can control and require judgment beyond what can be expected of children.
- **Under the influence.** Never operate, or let anyone else operate, the pressure washer while fatigued or under the influence of alcohol, drugs, or medication.
- **Understand intended use.** Carefully read about and understand the intended use of this pressure washer. Do not use for other purposes, as unforeseen hazards or equipment damage may result.

PROHIBITION AGAINST MODIFICATIONS

Never modify or alter the pressure washer in any way or deactivate any safety device. Modifications can create serious safety hazards and will also void the warranty.

- **Fuel/exhaust system.** Never add to or modify the exhaust system, fuel tank, or fuel lines. Carbon monoxide poisoning, fuel leaks, fire or explosion could result.
- **Unloader valve.** Do not attempt to alter the unloader valve's maximum pressure. Excess pressure could cause serious injury from escaping high-pressure fluids and/or pump damage. Any alteration other than turning the adjustment knob will void your warranty.
- **Guards.** Do not operate pressure washer unless all guards and cover shields are in place.

SAFETY – INSTALLATION & SET-UP

BATTERY SAFETY

Batteries are hazardous because they contain caustic acid, can emit explosive gases, and can cause electric shock. *Caution must be exercised when making connections to a battery to avoid shock and contact with the acid, and to prevent any sparking that could lead to an explosion.* Follow these and other safety rules carefully when connecting battery to pressure washer:

- **Eye/skin protection.** Always wear eye protection and protective clothing when connecting or disconnecting battery.
- **Sparks/Smoking.** Never smoke or work near sparks or other sources of ignition.
- **Electric shock.** Never touch both battery terminals at the same time with your hand or any non-insulated tools.
- **Connection/disconnection sequence.** ALWAYS connect and disconnect cables to the correct battery terminals in the proper sequence:
 - 1) When CONNECTING the battery, connect the RED cable to the POSITIVE terminal FIRST.
 - 2) When DISCONNECTING the battery, disconnect the BLACK cable from the NEGATIVE terminal FIRST.
- **Acid/skin contact.** If battery acid contacts skin or clothing, flush immediately with water and neutralize with baking soda.

INSTALLATION / INITIAL SET-UP

- **Level, heat-resistant surface.** Situate pressure washer on a firm, level, and heat-resistant surface with good drainage. Ensure it sits level and will not slide or shift during operation. Block wheels to prevent movement.
- **Prevent carbon monoxide poisoning – Use outside only!** Exhaust fumes from both the engine and the burner contain carbon monoxide (CO), a poisonous gas you cannot see, smell, or taste. The CO generated by the pressure washer can rapidly accumulate, even in areas that appear to be well-ventilated, resulting in dangerous and fatal concentrations within minutes. To prevent dangerous CO build-up:
- ONLY use pressure washer outdoors and at least 20 feet from the home, away from windows, vents, and air intakes, to allow proper

Summary of Important Safety Information

ventilation. If you start to feel sick, dizzy, or weak while using the pressure washer, shut off the engine and get to fresh air RIGHT AWAY.

- NEVER run pressure washer in an enclosed or partially enclosed location such as a building, garage, shed, or vehicle. Running a fan or opening windows will not provide adequate ventilation to prevent dangerous CO build-up.
- **Adequate ventilation.** The pressure washer needs adequate, unobstructed flow of air to allow for proper combustion and cooling. Situate so there is adequate clearance around pressure washer to allow for airflow – at least 7' from any non-combustible wall or obstruction. Never place any objects against or on top of pressure washer.
- **CO alarms.** Ensure that working, battery-operated or battery back-up carbon monoxide alarms are used in any dwelling/structure that is near the running pressure washer.
- **Hot exhaust - fires.** Exhausts from engine and burner can be extremely hot and cause fire. Position sprayer so engine and burner exhausts are at least 7' away from combustible objects during operation.
- **Spark arrestor usage.** Equip engine with a spark arrestor if pressure washer will be used near any ignitable forest, brush, or grassy land. See the Specifications section of this manual to determine if your pressure washer is already equipped. In such conditions, make sure you comply with applicable local, state, and federal codes.

FUEL SAFETY

Fuel is highly flammable and explosive; and burner fuels are combustible at warm temperatures. You can be burned or seriously injured when handling fuel. Using extreme care when handling fuel, including these preventative measures:

- **Fuel outdoors.** Fill fuel tank outdoors – never indoors. Fuel vapors can ignite if they collect inside an enclosure. Explosion can result.
- **Use approved container.** Never pump fuel directly into fuel tank at gas station. Static charge can build and ignite fuel. Use an UL approved fuel container to transfer fuel to the engine.
- **Running / hot engine.** A hot engine or burner is hot enough to ignite fuel. Never add fuel or remove fuel cap if engine or burner are running or still hot. Allow engine to cool at least two minutes before adding fuel.
- **Heat / flames / sparks.** Stay away from sources of heat, flame, or sparks while adding fuel.
- **Do not overfill.** DO NOT overfill the fuel tank. Allow at least 1/2" of empty space below the fill neck to allow for fuel expansion.
- **Replace cap.** Replace fuel cap securely before starting engine.
- **Spills.** Clean up fuel spills immediately. Move pressure washer away from spilled fuel on the ground. Wipe fuel off engine and wait 5 minutes for excess fuel to evaporate before starting engine. Fuel soaked rags should be disposed of properly.
- **On skin / clothes.** If fuel is spilled on your skin or clothes, change clothes and wash skin immediately.
- **Inspect fuel system.** Check fuel tanks and fuel system on a regular basis. Look for signs of leaks, deterioration, chafed or spongy fuel hose, loose or missing fuel hose clamps, damaged fuel tank, or a defective fuel shut-off valve. Do not start pressure washer until needed repairs have been completed.
- **Fuel storage.** Store fuel in a cool, dry place in an UL-approved, tightly sealed container.

SAFETY – OPERATION

PRE-START

- **Review safety rules.** Before each use of this pressure washer, review the "Rules for Safe Operation." Failure to follow these rules may result in serious injury or death.
- **Know how to stop.** Be thoroughly familiar with proper use of the equipment and all controls and connections. Know how to stop the pressure washer and relieve system pressure quickly if needed.
- **Danger: High-pressure fluid injection hazard.** High-pressure fluid spray or discharge from leaks (even pin-sized) or ruptured components can pierce the skin and inject fluid into the body. Injection injury can result in blood poisoning and/or severe tissue damage leading to infection, gangrene and possibly amputation.
- **Check/maintain machine before each use.** Check hoses & fittings for damage and leaks before use. Ensure all components are properly connected. Follow all maintenance instructions specified in pressure washer and engine manuals.
- Never operate machine with damaged or missing hoses/parts. Never attempt to repair a high-pressure hose or component. Always replace it with a part that is rated at or above the pressure rating of this machine.
- Never run the machine without enough lubrication or enough water to cool the pump.
- Never operate unless all safety guards are in place.
- **Position safely.** Place sprayer on firm, level ground to prevent accidental falls and equipment tip-over.
- **Not in presence of combustibles.** Do not use the pressure washer in the presence of flammable vapors, dust, gases, or other potentially combustible materials. Operate only where open flame or torch is permitted
- **Use backflow preventer.** The use of a back-flow preventer on the water supply hose is recommended and may be required by local code.
- **Clear work area.** Clear work area of all bystanders. Keep children and pets away.
- **Wear protective gear.** High-pressure spray can cause eye/skin injury, hot water can burn, and flying objects/debris can cause injury. Serious injection injury can result if high-pressure spray penetrates the skin. Operators should wear waterproof, thermally insulated gloves, safety

Summary of Important Safety Information

glasses with side and top protection, face protection, and protective clothing when operating the machine. If spraying pressure washer specific cleaning chemicals, wear a respirator or mask to avoid inhalation of vapors if directed on the chemical label.

- **Wear non-slip footwear.** Use of pressure washer can create puddles and slippery surfaces. Wear footwear capable of maintaining a good grip on wet surfaces.
- **Check sprayer nozzle.** Sprayer nozzle can become a projectile and cause serious personal injury or property damage if not properly connected to the spray gun. Check to ensure the nozzle has been properly attached to the spray gun before using the pressure washer.

DURING USE

- **Safety latch locked before starting engine.** Always engage the safety latch on the spray gun trigger before starting the engine.
- **Incoming water supply on.** Do not run the pump without the water supply connected and turned on. Operating the pressure washer without an incoming flow of water will damage the pump.
- **Wait before re-lighting burner.** NEVER attempt to immediately run or re-light the burner if it does not ignite the first time. Unburned oil or gas may have accumulated, causing potential explosion or fire hazard.
- **Use two hands.** Pressure washer spray gun kicks back when triggered. Firmly grasp with two hands.
- **Stay alert.** Always watch what you are doing.
- **Prevent slips / loss of balance.** High-pressure spray could cause you to lose balance from kickback forces, and wet surfaces can be slippery.
- Always keep good footing and balance. Do not overreach.
- Do not stand on unstable support when spraying.
- Use extreme caution when spraying from a ladder or scaffolding, ensure it is firmly anchored from sway or tip-over. Use extreme caution to avoid falling as spray gun kick can propel you off the ladder or scaffolding.
- Be aware of puddles and slippery surfaces. Ensure there is adequate drainage to prevent pooling of water.
- **Keep spray away from people.** Never direct discharge stream at or near any person. Do not allow any part of the body to meet the fluid stream. High-pressure spray will cause serious skin, eye, or falling injuries, and hot water can burn. Injection injury will occur if high-pressure spray pierces the skin, injecting liquid under the skin. Injection injury can result in blood poisoning and/or severe tissue damage leading to infection, gangrene and possibly amputation.
- **Prevent surface damage & flying debris.** – Surfaces being sprayed must be strong enough to withstand high-pressure spray, or damage may result. In addition, high-pressure spray will dislodge unsecured objects as well as surface chips and debris, resulting in hazardous flying objects that can cause personal injury or property damage. Do not spray brittle surfaces or breakable, fragile, or unsecured objects such as:
 - stucco or laminar flagstone
 - some painted surfaces
 - windows or glass doors (because they may break)
 - light fixtures, flowerbeds, mailboxes
 - unsecured, lightweight objects
- **Do not lock spray gun trigger in ON position.** To reduce risk of injury, do not attempt to secure the spray gun open by blocking or tying the spray gun in the open position.
- **Keep spray away from electrical wiring.** Spray contact with electrical wiring will likely result in severe electrical shock or electrocution.
- **Use only approved cleaning chemicals.** Only chemicals specifically designed for use in pressure washers may be used. Never spray acids, corrosives, or abrasive or flammable liquids. Breathing hazards, surface burns/corrosion, or fire/explosion could result.
- **Follow cleaning chemical manufacturer's instructions.** Follow the chemical manufacturer's label instructions when handling or spraying chemicals. Understand all safety hazards and first aid for all chemicals being used. Wear protective gear as directed. Always wear protective gloves when handling and cleaning with chemicals. When cleaning filters, check whether dangerous chemicals have been used with the filter and take any precautions that may have been recommended by the supplier of these chemicals. Always dispose of hazardous fluids per local, state, and national guidelines.
- **Do not exceed pressure and or temperature limits.** Do NOT operate this pump with components (such as hose, connections, and spray gun) rated for lower pressure and or temperature limits than the machine's maximum rated pressure and temperature, or component could rupture and cause serious personal injury from escaping high pressure fluids. Do not set the pressure safety device above the rated pressure. **If the high-pressure safety device ever discharges water, turn the engine off and do not use the machine. The device will no longer function properly. See a dealer or call Product Support at 1-800-969-7073.**
- **Never pull by hose.** Do not move this machine by pulling on the hose. Hose or connections could fail and result in catastrophic high-pressure release of fluid as well as hose whipping.
- **Avoid sharp objects.** Keep hose away from sharp objects. Bursting hoses may cause injury.
- **No load bearing.** Do not use the pump to support other items of equipment that impose unacceptable loads on the pump. Do not attempt to use this machine as a prop.
- **Hot exhaust/parts.** Stay clear of engine and burner exhausts. Never touch hot engine muffler, burner/heating coil, or other hot surfaces. All

Summary of Important Safety Information

are extremely hot and will burn you.

- **Hot spray gun metal when using burner.** Never touch the metal screw or any metal parts of the spray gun when the heater is being used – the metal gets extremely hot and will burn you.
- **Smoking/sparks.** Never smoke near the running engine, and never operate near sources of sparks or flames, as flammable fuel vapors are near the pressure washer.
- **Lock trigger safety latch when not spraying.** Spray gun is equipped with a built-in trigger safety latch to guard against accidental trigger release. Rotate safety latch to the locked position when not spraying.
- **Relieve water pressure.** Always stop the product and relieve system pressure before leaving the sprayer unattended, or when disconnecting hoses, removing nozzles, or servicing the pump.
- **Refueling.** Never add fuel to the engine or fuel to the burner unless unit is off and has cooled.
- **Do not direct spray at this machine.** Do not attempt to clean this machine with its own spray. Engine damage will result. Cleaning should be done with a damp sponge with the engine OFF.
- **Seek medical aid for suspected carbon monoxide poisoning.** The running engine gives off carbon monoxide, a poisonous gas that can kill you. If you start to feel sick, dizzy, or weak while using the pressure washer, shut off the engine and get to fresh air RIGHT AWAY. See a doctor. You may have carbon monoxide poisoning.
- **Seek medical aid for suspected injection injury.** If injured by high-pressure fluid, no matter how small the wound is, see a doctor at once. A typical injection injury may be a small puncture wound that does not look serious. However, severe infection or reaction can result if proper medical treatment is not administered immediately by a doctor who is familiar with injection injuries.
- **Other exhaust dangers.** This product contains or emits chemicals known to the State of California to cause cancer, birth defects or other reproductive harm. Avoid inhalation of exhaust.

AFTER USE

- **Cool engine before storing.** Let engine cool for at least five minutes before storing. A hot engine is a fire hazard.
- **Prevent accidental starting.** When pressure washer is not in use, remove spark plug or spark plug wire to ensure that pressure washer cannot be started in a storage location or by untrained persons.
- **Storage location.** Store the pressure washer in a dry location away from sources of heat, open flames, sparks, or pilot lights – such as water heaters, space heaters, furnaces, clothes dryers, or other gas appliances – EVEN IF the pressure washer's fuel tank is empty, residual vapors or fuel could ignite.
- **Periodic maintenance.** Perform periodic maintenance as directed in this manual to keep the pressure washer in safe working condition.

Safety - Inspection/Maintenance

Inspect and maintain your pressure washer on a regular basis and repair as needed to keep it in safe working condition:

- **Turn off / relieve pressure first.** Turn off pressure washer and relieve system pressure before inspection or maintenance. Remove spark plug or spark plug wire before working on the engine or pressure washer to prevent accidental starting.
- **Fuel valve off.** Turn fuel shut-off valve to OFF position before transporting or servicing the pressure washer.
- **Follow maintenance schedule.** Follow all maintenance instructions in this pressure washer manual and the engine manual.
- **Replace guards / shields.** Make sure all guards and shields are replaced after servicing the pressure washer.
- **Replacement parts.** If a part needs replacement, only use factory approved repair parts. Replacement parts that do not meet specifications may result in a safety hazard or poor operation of the pressure washer and will void the warranty.

Limited Warranty

Dear Valued Customer:

The NorthStar ProSHOT Product you just purchased is built with the finest material and craftsmanship. Use this product properly and enjoy the benefits from its high performance. By purchasing a NorthStar ProSHOT product, you show a desire for quality and durability. Like all mechanical equipment this unit requires a due amount of care. Treat this unit like the high-quality piece of machinery it is. Neglect and improper handling may impair its performance. Please thoroughly read the instructions and understand the operation before using your product. Always contact NorthStar ProSHOT Product Support at 1-800-969-7073 prior to having any service or warranty work performed, as some services performed by parties other than NorthStar ProSHOT approved service centers may void this warranty. This warranty is in lieu of any other warranty expressed or implied and NorthStar ProSHOT assumes no other responsibility or liability outside that expressed within this warranty.

Limited Warranty

NorthStar ProSHOT shall warranty any piece of equipment manufactured, or parts of equipment manufactured, to be free from defects in material or workmanship for a period of:

Item	Commercial/Consumer Warranty	Details
Structural Steel Components	8 years from date of purchase	NorthStar ProSHOT shall warrant structural steel components from failure for a period of 8 years from the date of purchase by user. Structural steel parts include but are not limited to, Roll cage, chassis, Pump/engine/generator mount, hose reel mount, fenders, bumper, tongue, tank platform, control box mount, battery mount, and ladder racks.
Heat Exchanger Coil Weldment	7 years from date of purchase	NorthStar ProSHOT shall warrant the Coil from defects in material or workmanship for a period of 7 years from the date of purchase by user. Warranty does not cover damage from freezing, or obstruction due to buildup of scale or soot.
General Pump	5 years from date of purchase, Life time on pump manifold	This warranty excludes all wear parts. For more details See General Pumps terms and Conditions
Engine	3 years from date of purchase	The engine warranty is covered under the terms and conditions as outlined by the engine manufactures warranty and is the sole responsibility of the engine manufacture. Normal engine maintenance such as spark plugs, air filters, adjustments, fuel system cleaning and obstruction due to build up is not covered by this NorthStar ProSHOT warranty.
NorthStar ProSHOT	2 years from date of purchase	The Balance of the machine less the other specific warranties mentioned.
Chemical injector & Unloader	1 year from date of purchase	NorthStar ProSHOT shall warrant the Chemical injector and Unloader valve from defects in material or workmanship for a period of 1 year from the date of purchase by user.
Normal Wear Items	90 days from date of purchase	In addition to the normal warranty, NorthStar ProSHOT shall warrant any normal wear item from defects in material or workmanship for a period of 90 days from the date of purchase by user. Normal wear items include, but are not limited to, nozzles, quick connect fittings, valves, high- and low-pressure water seals/packing, high- and low-pressure hoses, O-rings, filter elements, Electrodes, Gun, Lance, Tires, and Brakes

Limited Warranty

“Consumer use” means personal residential household use by a consumer. “Commercial use” means all other uses, including use for commercial, income producing or rental purposes or when purchased by a business.

This warranty applies to the original purchaser of the equipment (verification of purchase, in the form of a receipt, is the responsibility of the buyer), is non-transferable, and covers parts and labor. Parts will be replaced or repaired at no charge, except when the equipment has failed due to lack of proper maintenance. If a part is no longer available, the part may be replaced with a similar part of equal function. Any misuse, abuse, alteration or improper installation or operations will void warranty. Determining whether a part is to be replaced or repaired is the sole decision of NorthStar ProSHOT. NorthStar ProSHOT will not provide for replacement of complete products due to defective parts. Any costs incurred due to replacement or repair of items outside of a NorthStar ProSHOT approved facility is the responsibility of the buyer and not covered under warranty. Transportation costs to and from service center is the responsibility of the customer.

This warranty specifically excludes the following; failure of parts due to damage caused by accident, fire, flood, windstorm, acts of God, applications not approved by NorthStar ProSHOT in writing, corrosion caused by chemicals, use of replacement parts which do not conform to manufacturer’s specifications, damage related to the use of biodiesel fuel, damage to accessory parts such as starting batteries, damage related to rodent and/or insect infestation, Damage caused by freezing and damage caused by vandalism. Additional exclusions: loss of running time, inconvenience, loss of income, or loss of use, including any implied warranty of merchantability of fitness for a specific use. Also, Outdoor Power Equipment needs periodic parts and service to perform well, and this warranty does not cover instances when normal use has exhausted the life of a component or the engine.

This warranty does not cover any personal injury or damage to surrounding property caused by failure of any part. Repair or replacement of parts does not extend the warranty period.

Normal burner maintenance such as cleaning and adjusting electrodes, descaling the coil, desooting the coil, air adjustments, fuel system cleaning and obstruction due to build up is not covered by this NorthStar ProSHOT warranty.

The engine warranty is covered under the terms and conditions as outlined by the engine manufactures warranty contained herein and is the sole responsibility of the engine manufacture. Normal engine maintenance such as spark plugs, air filters, adjustments, fuel system cleaning and obstruction due to build up is not covered by this NorthStar ProSHOT warranty.

Please fill in the following information and have it on hand when you call in on a warranty claim.

Customer Number: _____

Date of Purchase: _____

NorthStar ProSHOT Serial Number: _____

Item Number: _____

This page is intentionally left blank.

WARNING: Breathing diesel engine exhaust exposes you to chemicals known to the State of California to cause cancer and birth defects or other reproductive harm.

- Always start and operate the engine in a well-ventilated area.
- If in an enclosed area, vent the exhaust to the outside.
- Do not modify or tamper with the exhaust system.
- Do not idle the engine except, as necessary.

For more information go to www.P65warnings.ca.gov/diesel.



Manufactured by
Northern Tool + Equipment Co., Inc.
Burnsville, MN 55306
NorthernTool.com