



M1574402A.2

ITEM NUMBER:	1574402, 1574403
SERIAL NUMBER:	_____

Owner's Manual

Pressure Washer: Machine that cleans dirty surfaces with high pressure water.

Instructions for Installation/Set-up, Operation, Maintenance, & Storage

This pressure washer produces cold-water high-pressure spray. Cleaning chemicals may be incorporated into the spray if desired. The pressure pump for this equipment is powered by a gasoline internal combustion engine.

<p style="text-align: center;">⚠ WARNING</p> <p style="text-align: center;">SPECIAL HAZARDS</p> <ul style="list-style-type: none">• CO Poisoning: Exhaust from engine contains carbon monoxide, a poisonous gas that can cause carbon monoxide poisoning and possible death if inhaled. ONLY run pressure washer OUTDOORS and at least 20 feet from the home, away from windows, vents and air intakes, to allow proper ventilation. If you start to feel sick, dizzy, or weak while using the pressure washer, shut off the engine and get to fresh air RIGHT AWAY.• Injection Injury: High-pressure spray can pierce skin and underlying tissues, leading to serious injury and possible amputation. Such an injection injury can result in blood poisoning and/or severe tissue damage.• Flying Debris: High-pressure spray can cause flying debris and possible surface damage.• Electric Shock: Operating equipment in wet conditions or near water can cause electric shock.• Chemical Exposure: Cleaning chemical vapors or contact with skin may be hazardous.• Fire/Explosion: Engine sparking can ignite fuel or other flammable liquids or vapors in the vicinity. Hot exhaust from engine can ignite combustible materials.• Burns: Pressure washer pump and engine are hot surfaces that can cause burn injuries. <p>Detailed safety information about these hazards appears throughout this manual.</p>
--

Equipment Protection Quick Facts

Inspect Upon Delivery: FIRST! Inspect for missing or damaged components. See "Initial Set-Up" section for where to report missing or damaged parts.

Add Engine Oil: Engine is shipped without oil. See engine manual for instructions on capacity and viscosity recommendations.

Pump: Pump is shipped with oil.

Water Flow Requirements: Make sure your supply water flow rate is 20% higher than the pressure washer's flow rate (see "Operations" section for detail) and that your water is clean and particle free.

Chemical Spraying: Use only approved pressure washer chemicals designed for high-pressure use.

Storage: Do not allow water to freeze in the pump, hose, or spray gun(s). See "Storage" for more information.

Maintenance Schedule: Engine and pump require periodic inspection and servicing to keep pressure washer functioning efficiently. See "Maintenance Schedule Summary" for frequency of servicing.

Any Questions, Comments, Problems, or Parts Orders
Call NorthStar Product Support 1-800-270-0810

Table of Contents

Equipment Protection Quick Facts	1
TABLE OF CONTENTS	2
ABOUT YOUR PRESSURE WASHER	4
SPECIFICATIONS	5
COMPONENT IDENTIFICATION	6
SAFETY	7
Hazard Signal Word Definitions	7
SAFETY LABELING	8
Safety Decal Locations	8
INITIAL SET-UP	10
Step 1. Inspect & Unpack	10
Step 2. Assembly	11
Handle & Billboard Assembly	11
Spray Gun Assembly	11
Step 3. Select Suitable Location	11
Moving and Handling	11
Outdoor Use Only	11
Install Spark Arrestor (if required)	12
OPERATION	13
Follow Safety Rules for Operation	13
Preparing for Operation	14
Check/Add Engine Oil	14
Inspect Fuel System/Check for Leaks	15
Connect Hoses, Water Supply, and Spray Nozzle	16
Prime the Water Supply	17
Set Up for Chemical Spray (if desired)	18
Start-Up Procedures	19
Start the Engine to Power the Pump	19
Apply Cleaning Chemical (if desired)	19
Begin High Pressure Spray	19
Shutdown	20
STORAGE	21
Between Use Storage	21
Prepare Pressure Washer for Freezing Conditions	21
Prepare Engine for Long Term Storage	22
Prepare Pressure Washer for Storage	22
MAINTENANCE & REPAIR	23
MAINTENANCE SCHEDULE SUMMARY	23
DETAILED INSTRUCTIONS – MAINTENANCE & REPAIR	23
Follow Safety Rules	23
Keep Pressure Washer Clean	23
Inspect Spray System	23

Clean Inlet Filter	24
TROUBLESHOOTING	26
PARTS EXPLOSION- MODEL #1574402, 1574403.....	27
PARTS LIST - MODEL #1574402, 1574403.....	28
PUMP EXPLODED VIEW – 803771	29
PUMP PARTS LIST – 803771	30
LIMITED WARRANTY	32
LIMITED WARRANTY CONTINUED	33
CALIFORNIA PROPOSITION 65 INFORMATION	34

About Your Pressure Washer

Thank you for purchasing a NorthStar Pressure Washer! It is designed for long life, dependability, and top performance.

Intended Use. Produce a high-pressure water spray. Incorporate cleaning chemicals into a low-pressure water spray.

Note: Do not use for other purposes, as unforeseen hazards or equipment damage may result.

Power Source. The pressure washer is powered by a gasoline engine.

Supplies Required. Normal operation will require you to supply:

- Gasoline
- Engine oil
- Personal Protection Equipment

See “*Specifications*” section of this manual for more detail.

Site Location. Intended for outdoor use only.

Personal Protection. Wear safety apparel during operation, including safety glasses with side and top protection. Ear protection is also recommended if working near any operating engine. Other safety apparel includes waterproof, insulated gloves and non-slip protective footwear. Cleaning chemicals may require the use of respiration mask; refer to the chemical label for further instruction.

Adult Control only. Only trained adults should set up and operate the pressure washer. Do not let children operate the pressure washer.

Under The Influence. Never operate, or let anyone else operate, the pressure washer while fatigued or under the influence of alcohol, drugs, or medication.

Keep this manual for reference and review.

ATTENTION: Rental Companies and Private Owners who loan this equipment to others!

All persons to whom you rent/loan this pressure washer to must have access to and read this manual. Keep this owner's manual with the pressure washer at all times and advise all persons who will operate the pressure washer to read it. You must also provide personal instruction on how to safely set-up and operate the pressure washer and remain available to answer any questions a renter/borrower might have. Owner's Manuals are available from NorthStar at 1-800-270-0810.

Specifications

1574402	
FLOW OUTPUT	
PSI (bar)	3200 (221)
GPM (l/min)	2.5 (9.4)
Max Water Temp	104° F (40°C)
ENGINE	
Engine	BRIGGS CR 950
Displacement	208 cc
DIMENSIONS/COMPONENTS	
Length	29.77"
Width	19.80"
Height	20.27"
Pump Model	V-PW 29/2.6
SUPPLIES REQUIRED (not included)	
Engine Oil	Refer to Engine Owner's Manual

1574403	
FLOW OUTPUT	
PSI (bar)	3300 (228)
GPM (l/min)	2.6 (9.8)
Max Water Temp	104° F (40°C)
ENGINE	
Engine	BRIGGS XR 1150
Displacement	250cc
DIMENSIONS/COMPONENTS	
Length	29.77"
Width	19.80"
Height	20.27"
Pump Model	V-PW 29/2.6
SUPPLIES REQUIRED (not included)	
Engine Oil	Refer to Engine Owner's Manual

Component Identification

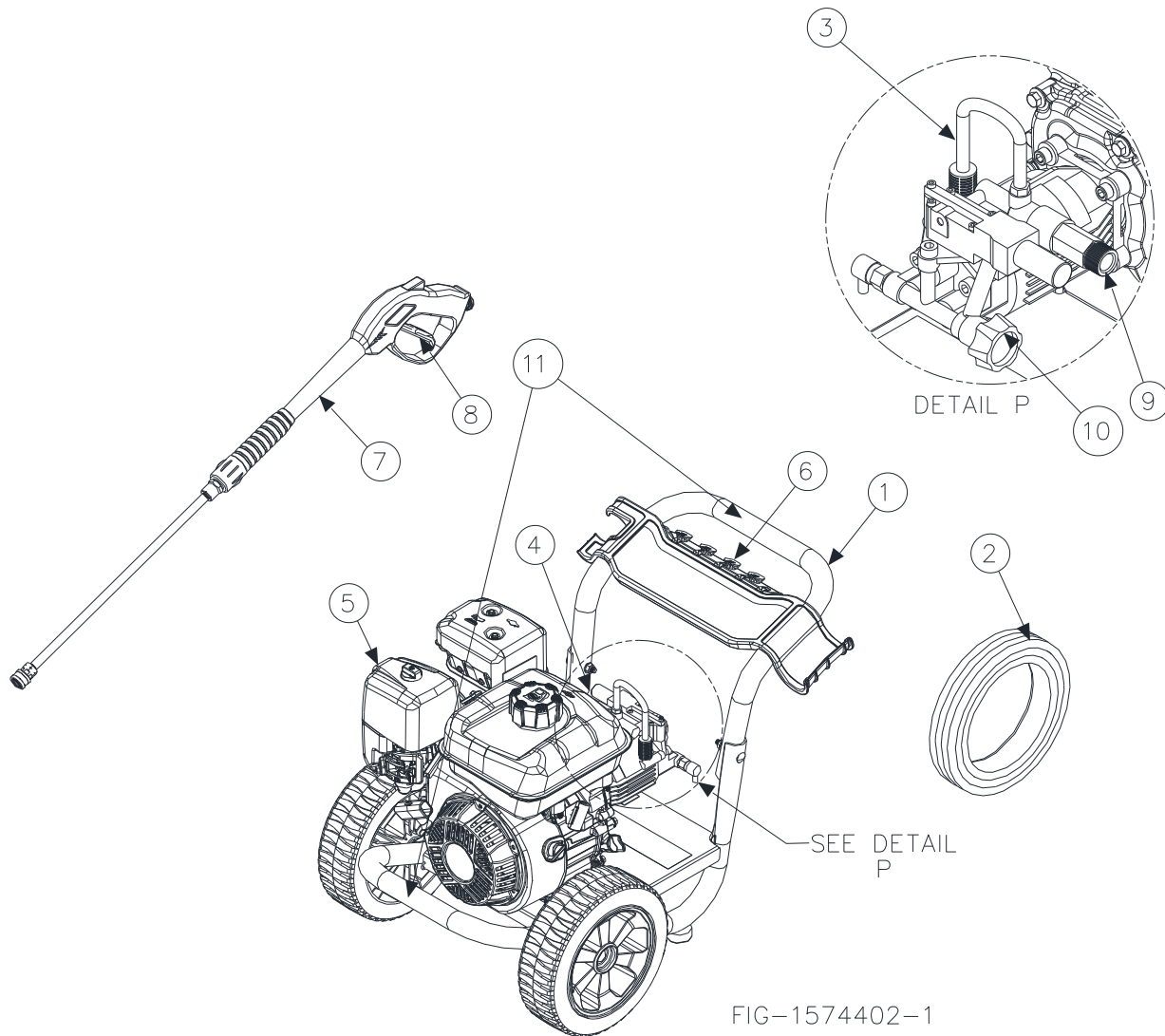

1. **Handle:** Designed for easy cart movement.
2. **Pressure Hose:** Attach quick couplers to gun and water outlet.
3. **Chemical Hose:** Submerge in cleaning solution.
4. **Water Pump:** Inspect for loose/broken parts prior to each use. A device that moves fluid through a combination of suction and displacement.
5. **Engine:** Briggs & Stratton engine provides years of reliable use. Air cooled engine that powers the pump.
6. **Nozzles:** Change nozzles for different spray patterns.
7. **Spray Gun:** Always use two hands for safe operation.
8. **Trigger:** Actuate to allow pressurized water to flow out of spray gun.
9. **High Pressure Outlet:** Connect your high-pressure hose.
10. **Garden Hose Inlet:** Connect water supply for pump
11. **Lifting Points:** Lift the pressure washer from these points when transporting.

See "Parts Explosion" for more details

Safety

Hazard Signal Word Definitions



This is the safety alert symbol. It is used to alert you to potential personal injury hazards. Obey all safety messages that follow this symbol to avoid possible injury or death.

DANGER (red) indicates a hazardous situation, which if not avoided, will result in death or serious injury.

WARNING (orange) indicates a hazardous situation, which if not avoided, could result in death or serious injury.

CAUTION (yellow) used with the safety alert symbol, indicates a hazardous situation, which if not avoided, could result in minor or moderate injury.

CAUTION (yellow) without the safety alert symbol, is used to address practices not related to personal injury.

NOTICE is used to address practices not related to personal injury.

Safety Labeling

Safety Decal Locations

WARNING

ALWAYS make sure safety labels are in place and in good condition. If a safety label is missing or not legible, order new labels from NorthStar Product Support at 1-800-270-0810.

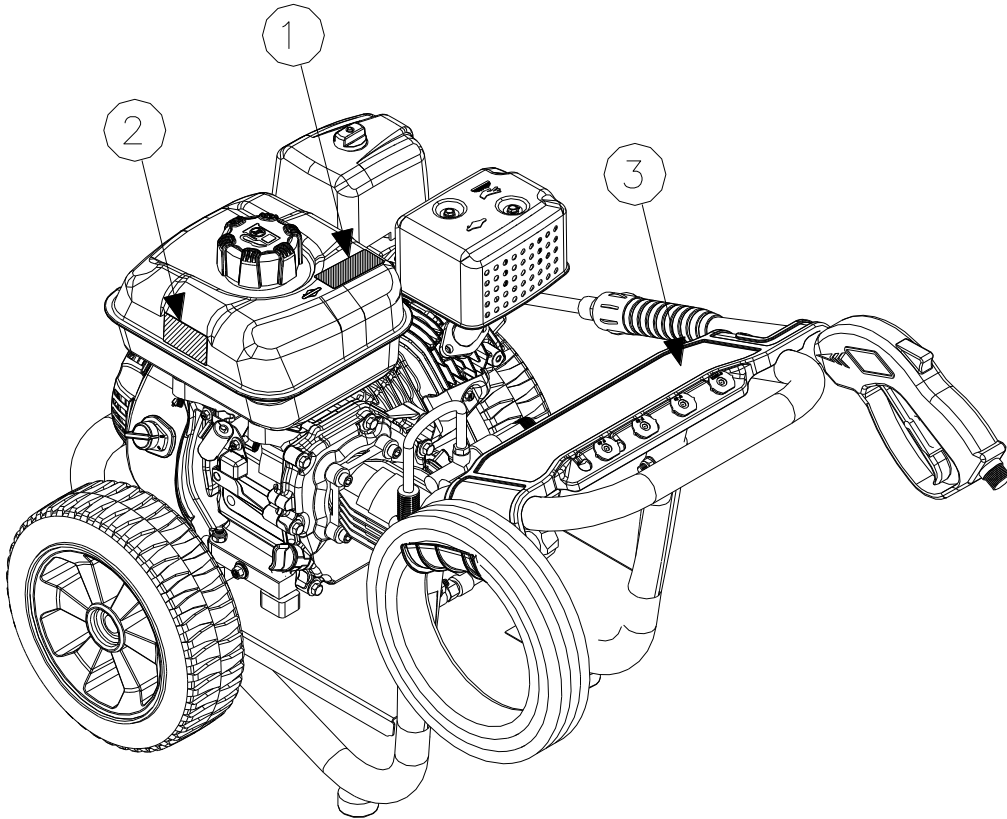

FIG-1574402-2

On-Product Warning Labels		
Location	Part Numbers	Description
1	790852	Burn Hazard Decal
2	803766	Fuel Fire Explosion Hazard
3	803687	Billboard Decal

Safety Labeling

Safety Decals

1

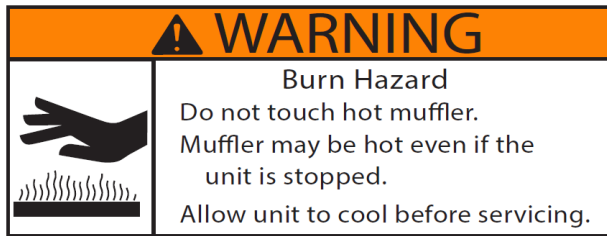

2

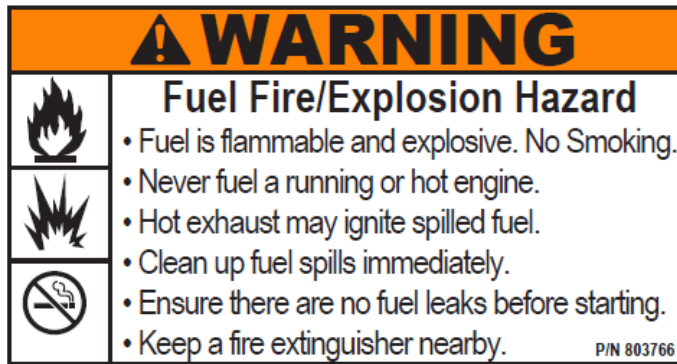

3

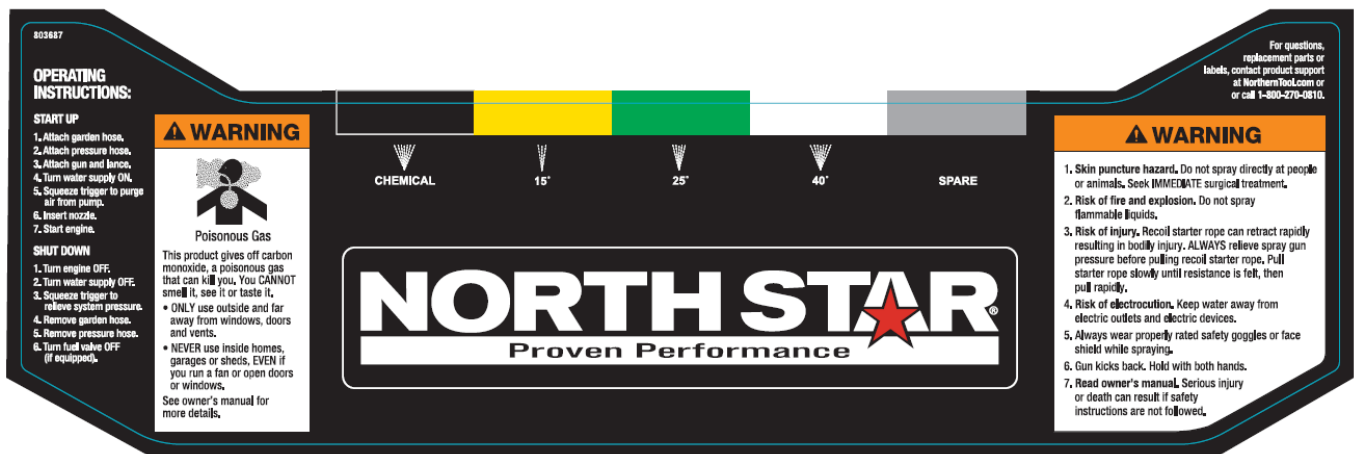

To order replacement safety labels, call NorthStar Product Support at 1-800-270-0810.

Initial Set-Up

Step 1. Inspect & Unpack

Upon receiving your item check for missing or damaged parts.

See “*Component Identification*” section of this manual for a diagram of the pressure washer and its components.

- For missing or damaged components, contact Product Support at 1-800-270-0810.
- If complete, fill out product serial number information. See “*Limited Warranty*” section of this manual.

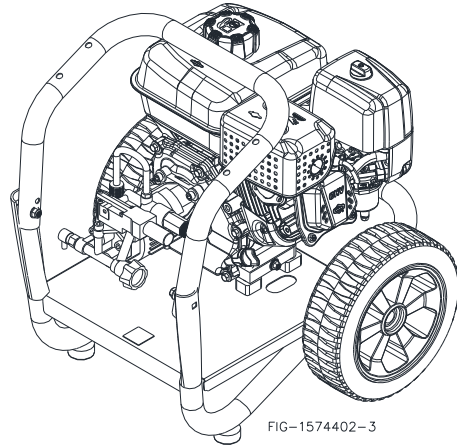

Engine/Pump/Base Assembly

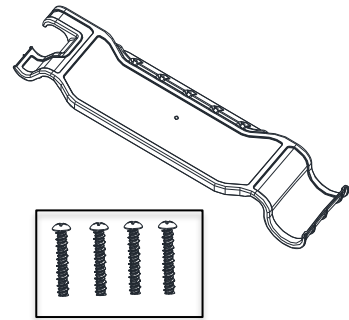

Billboard with Screw



Lance

FIG-1574402-12



Spray Gun

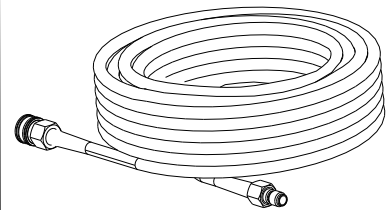

Pressure Hose

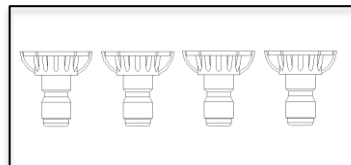

NOZZLES

Any Questions, Comments, Problems or Parts Orders call NorthStar Product Support at 1-800-270-0810.

Initial Set-Up

Step 2. Assembly

Note: Remove contents from packaging to begin assembly.

Handle & Billboard Assembly

1. Remove the backward handle.
2. Re-install handle in correct orientation using:
 - a. (2) Carriage Bolts (82233)
 - b. (2) Nut, Flange Nylock 5/16"(82630)
3. Attach billboard to handle using:
 - a. (4) Screws (803750)
4. Insert the Nozzle's into the billboard.

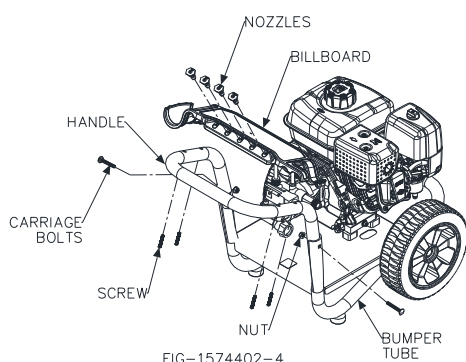

Spray Gun Assembly

5. Attach the Lance to Spray Gun
 - a.) Tighten spin-on coupler hand tight.

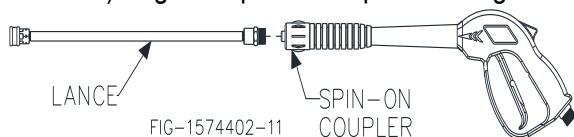

Note: The O-rings create a seal so there is no need to tighten with a wrench.

Step 3. Select Suitable Location

Moving and Handling

WARNING

Lifting Hazard

The pressure washer is heavy. It can crush and cause serious injury if it rolls out of control or tips over. Follow the instructions below for safely moving the pressure washer.

Moving your pressure washer around

- Use the handles to manually move the pressure washer.
- Push the pressure washer in front of you or pull the pressure washer behind you.

- To turn, pull up slightly on the handles and pivot the pressure washer on its wheels.

Elevating or lowering your pressure washer

- To reduce risk of injury, it is recommended that two adults lift the pressure washer.
- Only lift the pressure washer by the bumper and handle. Do not use the pump or engine as a lifting point.

Outdoor Use Only

WARNING

Location Hazards

Choose a suitable site for operating your pressure washer to prevent possible death from carbon monoxide poisoning or injury from fire/explosion, hot surfaces or equipment tip-over.

Select a suitable outdoor location:

1. Never run the pressure washer in an enclosed or partially enclosed location such as a building, garage, barn, shed, or house. These spaces can trap poisonous gases. Running a fan or opening windows will not provide adequate ventilation to prevent dangerous CO build-up.
2. Only use the pressure washer outdoors at least 20 feet from the home, away from windows, vents, and air intakes, to allow proper ventilation. If you start to feel sick, dizzy, or weak while using the pressure washer, shut off the engine and get to fresh air RIGHT AWAY.
3. Position the pressure washer so that the exhaust fumes will not be directed towards people or building air intakes.
4. Do not locate and use the pressure washer in the presence of flammable vapors, dust, gases, or other potentially combustible materials.
5. Ensure that working, battery-operated or battery back-up carbon monoxide alarms are used in any dwelling/structure that is in close proximity to the running pressure washer.
6. Note that this pressure washer is NOT designed or approved for use in vehicles or marine applications. Never run the pressure washer inside RVs or other vehicles, on boats, or on pick-up truck beds.

Initial Set-Up

Positioning:

1. The pressure washer should be positioned on a firm, level (less than 3-degree slope), heat-resistant surface with good drainage and a nearby water supply.
2. The pressure washer should be placed within garden hose distance of a continuous water supply. Ensure that the pressure washer sits level and will not slide or shift during operation. If applicable, block the pressure washer's wheels to prevent movement.
3. Situate so there is adequate pulling room for starting the engine using the recoil starter. Attempting to pull at an odd angle could rip off grip cord and/or cause muscular injuries to the operator.
2. Make sure the engine is at least 7 feet from all combustible materials and structures during operation.
3. Keep a fire extinguisher rated "ABC" nearby. Keep it properly charged and be familiar with its use.
4. Place the pressure washer so that the exhaust fumes will not be directed towards people or building air intakes.

Airflow:

1. Situate so there is adequate clearance around pressure washer to allow for airflow – at least 7 feet from any non-combustible wall or obstruction.
2. Do not operate with a tarp, blanket, or cover surrounding the pressure washer.
3. Do not place any objects against or on top of the pressure washer.
4. The pressure washer needs adequate, unobstructed flow of air to allow for proper combustion and adequate cooling. Proper combustion can only be obtained when there is a sufficient supply of oxygen available for the amount of fuel being burned. Cooling ventilation is required to prevent overheating of the pressure washer and possible fire.

Exhaust:

WARNING

Exhaust Modification Hazard

Never attempt to attach ductwork to the muffler system to allow for installation inside an enclosure. This could cause heat build-up and increased exhaust back-pressure, resulting in possible exhaust leakage or damage to the pressure washer.

1. The exhaust gas from your pressure washer is extremely hot and can cause combustible materials to catch on fire.

⚠ DANGER

Carbon Monoxide Hazard

Exhaust fumes from the engine contain carbon monoxide (CO), a poisonous gas you cannot see, smell, or taste. The CO generated by the engine can rapidly accumulate, even in areas that appear to be well ventilated, resulting in dangerous and fatal concentrations within minutes. NEVER run pressure washer inside any enclosed or semi-enclosed spaces, including homes, garages, basements, sheds, boxes, pick-up truck beds, RVs, or boats. These spaces can trap poisonous gases, EVEN if you run a fan or open windows. If you start to feel sick, dizzy, or weak while using the pressure washer, shut off the engine and get to fresh air RIGHT AWAY. See a doctor. You may have carbon monoxide poisoning.

Install Spark Arrestor (if required)

Equip engine with spark arrestor if pressure washer will be used near any ignitable forest, brush, or grassy land. (See engine Owner's Manual provided to determine if the engine is already equipped.) Make sure you comply with applicable local, state, and federal codes.

Operation

Follow Safety Rules for Operation

After you have checked and fueled the equipment and positioned it in a suitable worksite, it is time to start your pressure washer. The following are the procedures necessary for safe, successful operation of your pressure washer.



WARNING

Failure to follow safety rules may result in serious injury or death to the operator or bystanders.

Instruct Operators. Owner must instruct all operators in safe set-up and operation. Do not allow anyone to operate the pressure washer who has not read the Owner's Manual and been instructed on safe use practices.

Safety Equipment/Controls. Always operate with all safety covers, guards, and barriers in place and in good working order, and all controls properly adjusted for safe operation.

Moving Parts. Keep hands, feet, hair, and apparel away from moving parts. Air vents may cover moving parts and should be avoided as well. Never remove any guards while the pressure washer is operating.

Ear Protection. Hearing can be damaged from prolonged, close-range exposure to the type of noise produced by this pressure washer. The use of ear plugs or other hearing protection devices is recommended for persons working within 15-20 feet of the running pressure washer for an extended period of time.

Eye Protection. Wear ANSI "Z87.1" required safety glasses when operating or servicing the pressure washer. Pressurized spray from this pressure washer can cause severe injury to the eyes. Small objects can become airborne as the spray contacts them.

NOTE!

Before starting the pressure washer, review the following general safety rules for operation:

Conditions for Use

Know How to Stop. Be thoroughly familiar with proper use of the equipment and all controls and connections. Know how to stop the pressure washer and depressurize the system quickly if needed.

Instruct All Operators. The pressure washer's owner must instruct all operators and potential renters in safe set-up and operation. Do not allow anyone to operate

the pressure washer who has not read the Owner's Manual and been instructed on its safe use.

Adult Control only. Only trained adults should set up and operate the pressure washer. Do not let children operate. Pressure washers can generate forces greater than children can control and require judgment beyond what can be expected of children.

Under the Influence. Never operate, or let anyone else operate, the pressure washer while fatigued or under the influence of alcohol, drugs, or medication.

Safety Equipment / Controls in place. Do not operate the pressure washer unless all safety covers, guards, and barriers are in place and in good working order, and all controls are properly adjusted for safe operation.

Damaged. Do not operate the pressure washer with damaged, missing, or broken parts. Never attempt to repair a high-pressure hose or component. Always replace it with a part that is rated at or above the pressure rating of the pressure washer.

Modifications. Do not modify the pressure washer in any way or deactivate any safety device. Do not change or add to fuel tank, fuel lines, or exhaust system. Modifications can result in hazards related to carbon monoxide poisoning, fuel leaks, fire, explosion, or other serious safety hazards, and will also void the warranty.

During Use

Stay alert. Watch what you are doing at all times.

Clear work area. Clear the work area of all bystanders.

Keep children and pets away.

Keep spray away from electrical wiring. Spray contact with electrical wiring will likely result in severe electrical shock or electrocution.

Do not point gun at people or animal. It may result in serious injury or death.

Hot exhaust/parts. Stay clear of engine exhaust. Never touch a hot engine muffler, or other hot surfaces. All are very hot and will burn you.

Do not direct spray at this pressure washer. Do not attempt to clean this pressure washer with its own spray. Engine damage will result. Cleaning should be done with a damp sponge with the engine OFF.

Let engine cool at least two minutes before refueling.

Operation

Avoid inhalation of exhaust. Running this pressure washer indoors can kill you in minutes. Exhaust contains carbon monoxide. This is a poison you cannot see or smell.

Never pull by hose. Do not move this pressure washer by pulling on the hose. Hose or connections could fail and result in catastrophic high-pressure release of fluid as well as hose whipping.

Avoid sharp objects. Keep hose away from sharp objects. Bursting hoses may cause injury.

No load bearing. Do not use the pump to support other items of equipment that impose unacceptable loads on the pump. Do not attempt to use this pressure washer as a prop.

Lock trigger safety latch when not spraying. Spray gun is equipped with a built-in trigger safety latch to guard against accidental trigger release. Rotate safety latch to the locked position when not spraying.

Leaving unattended. Always turn off the pressure washer and relieve system pressure before leaving the sprayer unattended.

Prompt Emergency Response

Seek medical aid for suspected injection injury. If injured by high-pressure fluid, no matter how small the wound is, see a doctor at once. A typical injection injury may be a small puncture wound that does not look serious. However, severe infection or reaction can result if proper medical treatment is not administered immediately by a doctor who is familiar with injection injuries.

Seek medical aid for suspected carbon monoxide poisoning. The running engine gives off carbon monoxide, a poisonous gas that can kill you. If you start to feel sick, dizzy, or weak while using the pressure washer, shut off the engine and get to fresh air RIGHT AWAY. See a doctor. You may have carbon monoxide poisoning.

Wear Personal Protective Gear

WARNING

Wear personal protective gear to prevent:

- Eye and skin injection injury from high pressure spray
- Eye injury from flying debris

1. Wear waterproof gloves, ANSI Z87.1 compliant safety goggles, face protection, and protective clothing when operating the pressure washer.

If spraying pressure washer specific chemicals, wear a respirator mask to avoid inhalation of vapors if directed on the chemical label.

2. Wear non-slip, protective footwear. Use of pressure washer can create puddles and slippery surfaces. Wear footwear capable of maintaining a good grip on wet surfaces.

Preparing for Operation

Make sure that any regular maintenance has been performed as prescribed in “*Maintenance & Repair*” section.

Check/Add Engine Oil

Use the recommended oil type for your engine and expected ambient conditions. (See engine Owner's Manual for oil type and capacity, and more detailed oil check/fill instructions.)

WARNING

Burn Hazard

Never open oil port while engine is running. Hot oil can spray over face and body.

Notes:

- Low oil shutdown feature prevents the engine from starting without sufficient oil.
- Engine is shipped without oil. You must add oil before first use.

Operation

Add Fuel

⚠ WARNING

Fuel Fire/Explosion Hazard

Gasoline is highly flammable and explosive. Heat, sparks, and flames can ignite fuel vapors, which can become widespread during fueling. A flash fire and/or explosion could result and cause serious injury or death. Always use extreme care when handling fuels. Carefully follow all instructions to avoid the following conditions which could result in fuel ignition:

- gas vapor collection inside enclosures
- static electric sparks
- sparks from electric wiring, batteries, or running engines
- sources of heat (such as a hot engine exhaust)
- open flames, including pilot lights

Always follow these general safety rules when fueling:

1. Turn pressure washer off and allow to cool for at least two minutes before removing any fuel cap. Note: A running or still-hot engine is hot enough to ignite fuel.
2. Fill fuel tank OUTDOORS – never indoors. Fuel vapors can ignite if they collect inside an enclosure and explosion can result.
3. Stay away from all sources of heat, sparks, and flames. Do not smoke.
4. Never pump fuel directly into the gas tank at a gas station – it could cause a static electric spark. Follow these steps to avoid static electric sparking during fueling:
 - Use an approved portable container to transfer fuel to the pressure washer's tank. (A portable container made of metal or conductive plastic is preferred because it dissipates charge to ground more readily.)
 - Always place container on the ground to be filled. Never fill the portable gas container while it is sitting inside a vehicle, trailer, trunk, or pick-up truck bed.
 - Dissipate static charge from your body before beginning the fueling process by touching a grounded metal object at a safe distance from fuel sources.
 - Keep nozzle in contact with container while filling. Do not use a nozzle lock-open device.
5. Clean up fuel spills/splashes immediately.

- If possible, move the pressure washer away from spilled fuel on the ground.
- Wipe up spilled fuel and wait 5 minutes for excess fuel to evaporate before starting engine.
- Fuel soaked rags are flammable and should be disposed of properly.
- If fuel is spilled on your skin or clothes, change clothes and wash skin immediately.

Fill Engine Fuel Tank

Check the gasoline tank level. If needed, fill tank with fresh unleaded gasoline from a portable container:

1. Remove engine gas cap.
2. Add gasoline through the fill opening:
 - Use only a UL-approved portable gasoline container to transfer the gasoline to engine's tank.
 - Do NOT overfill the gasoline tank. Allow at least 1/2" of empty space below the fill neck to allow for fuel expansion.
3. Replace gas cap securely before starting engine.
4. Store extra gasoline in a cool, dry place in a UL-approved container.



Inspect Fuel System/Check for Leaks

Inspect the engine fuel system and check for leaks before each use.

Do not start pressure washer until all needed repairs have been completed.

⚠ WARNING

Fuel Leak Hazard

Gasoline fuel is highly explosive and fuel leaks can result in fire or explosions. You can be burned and seriously injured if the fuel system is not properly hooked up or there is a fuel leak when you start the engine.

Inspect the entire fuel system. Look for:

- signs of leaks or deterioration
- chafed or spongy fuel hose

Operation

WARNING

High Pressure Fluid Injection Hazard

High-pressure fluid discharge from leaks (even pin-sized) or ruptured components can pierce skin and inject fluid into the body. Injection injury can result in blood poisoning and/or severe tissue damage leading to infection, gangrene, and possibly amputation.

- Never use a finger or skin to check for leaks.
- Never operate pressure washer with damaged or missing hoses/parts.
- Never attempt to repair a high-pressure hose or component – Always replace it with a part that is rated at or above the pressure rating of this pressure washer.

- loose connections
- loose or missing fuel hose clamps
- damaged fuel tank or
- defective gasoline shut-off valve

Inspect Spray System

Always inspect spray system for damage and leaks before each use. Do not start pressure washer until all needed repairs have been completed.

Perform Scheduled Maintenance, As needed

Make sure that any other regular maintenance has been performed as prescribed in this manual in the "Maintenance Schedule Summary" section.

Refer to the engine Owner's manual for engine maintenance instructions.

Connect Hoses, Water Supply, and Spray Nozzle

Position Pressure Washer for use

- For detailed instruction on positioning your pressure washer for use, turn to the "Initial Set-Up" section of this manual and reference "Step 3: Select Suitable Location".
- Where no flammable vapors, dusts, and gases are present.
- Where there is adequate, unobstructed ventilation airflow.
- With adequate clearance from combustible materials.
- On a firm, level, heat-resistant surface with good drainage and nearby access to a continuous water supply.

Attach Garden Hose to Water Inlet

1. Make sure the water supply is clean. Debris can cause excess pump wear and reduce performance.
2. An insufficient water supply will damage your pump. Make sure the water supply is steady and is 20% over the rated flow of your pump. Use a stopwatch to time how long it takes to fill a 5-gallon bucket with your garden hose. The bucket must fill faster than the times listed in the table below.

Model#	Time to Fill 5 Gallon Bucket
1574402	100 sec
1574403	100 sec

3. The water supply garden hose must have an inside diameter of at least 5/8". If the hose is more than 100 ft. long, the diameter must be at least 3/4".
4. Never use a reservoir tank as a water source. Drawing water out of a tank may cause pump cavitation and damage to your pump. This pressure washer is designed for a pressurized water source such as a city water faucet. However, the water source pressure must not exceed:

Model#	Max. Inlet psi
1574402	60 psi
1574403	60 psi

5. Always use a flexible rubber hose for your water supply. Do not use rigid piping.

Attach High Pressure Hose to Spray Gun and Water Outlet

WARNING

High Pressure

NEVER operate this pump with components (such as hose, connections, and spray gun) rated for lower pressure and/or temperature limits than the pressure washer's maximum rated pressure and temperature, or component could rupture and cause serious personal injury from escaping high pressure fluids.

1. See "Component Identification" section of this manual for location of the pressure washer's water outlet.
2. To attach the pressure hose to the spray gun, spin the pressure hose's coupler onto the spray gun's inlet, hand tight.

Operation

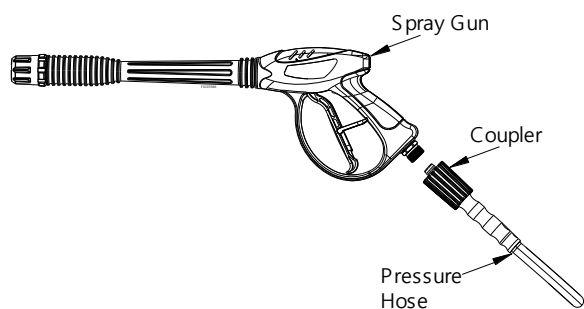

Select Nozzle for Spray Gun

Your pressure washer is equipped with four high-pressure nozzles and one low-pressure nozzle. Generally, the wider the spray angle of the nozzle, the lower the spray impact produced. Select the appropriate nozzle for the job based on the following table:

Color of Nozzle:	Spray Angle	Used For
Yellow	15	Tough Stains/Stripping
Green	25	General
White	40	Light Cleaning
Black (Low Pressure)*	65	Chemicals

* NOTE: You must use the low-pressure black nozzle for spraying chemicals.

Attach Nozzle to Spray Gun

⚠ WARNING

Depressurize First

Any time you remove/install/change a nozzle, you must depressurize hose line by squeezing the spray gun trigger while the engine is off. Even if the engine has been off for a long period of time, the hose may remain dangerously pressurized.

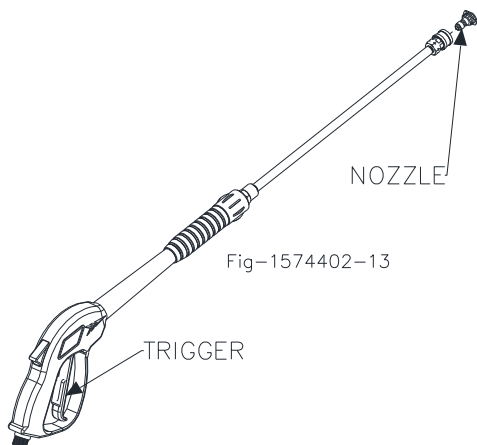

1. Make sure the engine is off and the hose line is depressurized.
2. To install the nozzle, pull the collar back and twist the nozzle firmly into the coupler on the end of the wand.

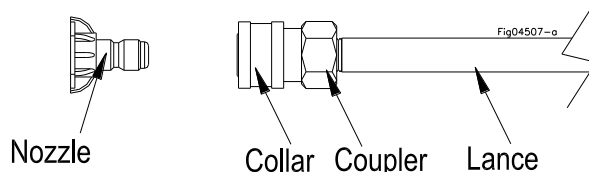

3. Release the collar, making sure it springs back and re-seats to its original (non-retracted) position. *Check the connection by pulling on the nozzle to ensure a tight connection -- if correctly inserted, nozzle will rotate but not pull out.*

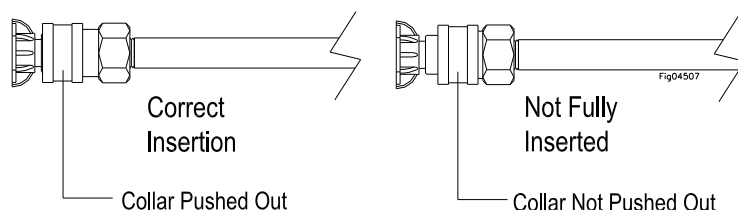

Prime the Water Supply

Turn On Water Supply and Squeeze the Trigger

CAUTION: Water Pressure

Never run the pump without the water supply connected and turned on. Operating the pressure washer without a sufficient incoming flow of water will damage the pump.

- Turn on the water supply. Make sure the water supply is steady and flowing at a rate 20% over the rated flow of your pump. (Reference the flow rate table under the Connect Hoses, Water Supply, and Nozzle" section.)
- Purge air from the water supply hose by squeezing the trigger until a steady stream of water flows out of the nozzle at low pressure. (Air in the hoses can cause damage to the pump, so always make sure all the air is out of the hoses before starting the pressure washer engine.)
- Make sure the water supply hose is not kinked. A kinked hose will provide insufficient water supply to the pump and reduce its life. Make sure the hose remains unkinked after moving the pressure washer.

Operation

Set Up for Chemical Spray (if desired)

Prepare for Chemical Spray (if planning to use)

Using the proper cleaning chemical for the application can speed up cleaning jobs tremendously.

Your pressure washer is equipped with a chemical injection point on the downstream side of the pump for introducing cleaning chemicals into the water stream. A braided chemical hose is provided to connect at this point. Suction pressure at this connection automatically draws the chemical solution in through the hose, mixing in 1-part chemical to 15 parts water. Adequate suction pressure is created only when the low pressure (black) spray nozzle is used.

The introduction of cleaning chemicals via the chemical injection point affords the following advantages:

- It protects the pump from damage because no chemical passes through the pump.
- It mixes the cleaning chemical into a low-pressure spray. Cleaning chemicals applied under low pressure adhere better to the surface being cleaned, allowing the formula time to react and remove dirt more effectively.

Note: An external *upstream chemical injector* is not recommended for use with this pressure washer, and if used would alter the 15-to-1 dilution ratio and may cause pump damage.

CAUTION

Chemicals Containing Muriatic Acid

Certain chemicals, such as bleach or those containing muriatic acid, will cause pump damage if introduced upstream through the pump's water inlet. Use of chemicals not intended for pressure washers will void pump warranty.

⚠ WARNING

Chemical Spraying

- Never spray acids, corrosives, or abrasive or flammable liquids. Breathing hazards, surface burns/corrosion, or fire/explosion could result.
- Follow the chemical manufacturer's label instructions for proper use and handling of the chemical. Understand all safety hazards and first aid for all chemicals being used. Always wear protective gloves when handling and cleaning with chemicals, and wear other protective gear as directed by chemical manufacturer. Always dispose of hazardous fluids per local, state, and national guidelines.

Acquire Cleaning Chemical

Use only approved pressure washer chemicals or chemicals specifically formulated for use with pressure washers.

CAUTION

Non-approved Chemicals

Non-approved chemicals can damage pressure washer components (seals, wand, hoses, pump, etc.) and be harmful to the environment.

Prepare for Chemical Spray (If Planning to Use)

Prepare the pressure washer for chemical spraying using the following steps:

1. Prepare (dilute) chemical cleaning solution as required for the job.
Note: the chemical solution will be automatically mixed with the water at a ratio of 15 parts water to 1-part chemical solution.
2. Press the braided chemical hose over the chemical injector on the pump.
3. Submerge the suction strainer connected to the braided chemical hose into a bucket containing the chemical solution.

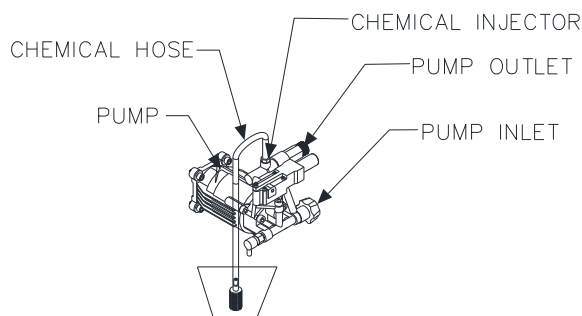

FIG-1574402-5

Operation

Start-Up Procedures

Start the Engine to Power the Pump

1. Make sure water supply is connected and primed.

CAUTION

Warranty Void

Running the pump dry will cause damage and void the warranty.

2. To prevent accidental spraying, engage the safety latch on spray gun trigger by rotating it to the locked position.
3. Follow the instructions in the Engine Owner's Manual for starting the engine.
 - If the engine doesn't start on the first try, pressure may build up in the pump. Relieve pressure by squeezing the spray gun trigger before attempting to start engine again. This will make starting easier.

⚠ DANGER

Engine Exhaust

Do not inhale engine exhaust. It contains dangerous carbon monoxide that can kill you.

Apply Cleaning Chemical (if desired)

1. Make sure the chemical injector is properly set up according to the instructions. Reference "Set Up for Chemical Spray" on the previous page.
2. Make sure the low-pressure BLACK nozzle is attached before beginning to spray chemicals. *Only the low-pressure black nozzle will allow chemicals to be drawn through the chemical injector into the water stream.*
3. Apply chemicals by squeezing the spray gun trigger. The chemical injector will draw the chemical into the water stream.
4. Apply chemicals evenly to the cleaning surface. Never use more chemical than is necessary to clean the surface.
5. Allow the chemicals time to react with the dirt before rinsing.
6. Prepare to rinse by changing to a high-pressure nozzle. Changing the nozzle from the low-pressure black nozzle to a high-pressure nozzle will stop the flow of chemicals into the water stream.

Instructions for selecting a nozzle can be referenced in the "Connect Hoses, Water Supply, and Spray Nozzle" section. See the subsection "Select Nozzle for Spray Gun".

7. Rinse with high-pressure spray as instructed below:

Begin High Pressure Spray

⚠ WARNING

High - Pressure Spraying Safety

- **Keep spray away from people.** Never direct discharge stream at or near any person. Do not allow any part of the body to come in contact with the fluid stream. High-pressure spray can cause serious skin, eye, or falling injuries. Injection injury will occur if high-pressure spray pierces the skin, injecting liquid under the skin. Injection injury can result in blood poisoning and/or severe tissue damage leading to infection, gangrene and possibly amputation. Seek medical attention.
- **Do not secure trigger open.** To reduce risk of injury, do not attempt to secure the spray gun open by blocking or tying the spray gun in the open position.
- **Prevent slips / loss of balance.** High-pressure spray could cause you to lose balance from kickback forces, and wet surfaces can be slippery.
 - Keep good footing and balance at all times. Do not overreach.
 - Do not stand on unstable support when spraying.
 - If spraying from an elevated surface, use fall protection because spray gun kickback can propel you off the elevated surface. When spraying from a ladder or scaffolding, ensure it is firmly anchored from sway or tip-over.
 - Be aware of puddles and slippery surfaces. Ensure there is adequate drainage to prevent pooling of water.
- **Prevent surface damage & flying debris.** Surfaces being sprayed must be strong enough to withstand high-pressure spray or damage may result. In addition, high-pressure spray will dislodge unsecured objects as well as surface chips and debris, resulting in hazardous flying objects that can cause personal injury or property damage. Do not spray brittle surfaces or breakable, fragile, or unsecured objects such as:
 - stucco or laminar flagstone
 - some painted surfaces
 - windows or glass doors, or mailboxes they may break)
 - light fixtures, flowerbeds, mailboxes
 - unsecured, lightweight objects

Operation

Procedure:

1. Put on one of the high-pressure spray nozzles (always relieve system pressure first and follow instructions for attaching a nozzle).
2. Clear the cleaning area of all persons. Keep children and pets away.
3. Hold the spray gun firmly with two hands and a sturdy stance -- Gun kicks back when triggered.
4. Wash from the bottom to the top, using side-to-side motions. This washes away heavy dirt and allows the detergent to soak as you work toward the top.
5. Use the width of the spray pattern to wash a wide path. Overlap spray paths for complete coverage.
6. The nozzle should be 12" to 24" from the work, closer for tough areas.
7. Small parts should be washed in a basket so the pressure does not push them away. Larger, lightweight parts should be clamped down.
8. The pressure washer is set and locked to the maximum rated pressure when it leaves the factory.

WARNING

Warranty Void

Do not attempt to alter the unloader valve's maximum pressure. Excess pressure could cause serious injury from escaping high-pressure fluids and/or pump damage. Any alteration other than turning the adjustment knob will void your warranty.

9. If temporarily interrupting spraying, rotate trigger safety latch downward to the locked position to guard against accidental trigger release

Spray Gun Safety Lock

When not spraying, use the spray gun safety lock to prevent accidental high-pressure discharge.

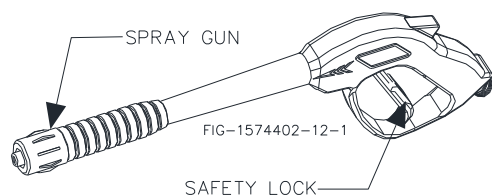

10. Always turn off the engine and activate spray gun trigger to relieve system pressure when:
 - the sprayer is unattended, or
 - disconnecting hoses, installing/cleaning nozzles, or servicing the pump.

WARNING

Injury

Always turn off the engine and relieve system pressure when finished spraying or when leaving sprayer unattended. Serious injury could result from unintentional release of high-pressure spray.

Shutdown

WARNING

Injury

Never disconnect the high-pressure hose from the pump or spray gun while the system is pressurized. Relieve pressure by squeezing the spray gun trigger after the engine is turned OFF.

Stop the engine using the following steps:

1. Turn engine OFF.
2. Turn water supply OFF.
3. Squeeze trigger to relieve system pressure.
4. Remove garden hose.
5. Remove pressure hose.
6. Remove nozzle from spray gun.
7. Turn gasoline line valve to the OFF position.
8. If chemicals were used, remove chemical injector tube from the pump.
9. Cool engine at least five minutes before storing; a hot engine is a fire hazard.

Storage

When you are finished using the pressure washer, you must prepare the sprayer for storage and store it in a proper location.

Between Use Storage

Perform periodic maintenance as directed in this manual to keep the pressure washer in safe working condition.

Choose a storage location that is:

- Clean and dry.
- Away from sources of heat, open flames, sparks, or pilot lights, even if the pressure washer's engine fuel tank is empty. Residual fuel fumes from tank can ignite.
- Away from extreme high or low temperatures. Do not store the pressure washer in freezing conditions unless it is prepared as directed below for those conditions.

Note:

- **If you will be storing the pressure washer in freezing conditions**, follow the instructions for preparing the sprayer for storage in freezing conditions.
- **If you will not be using the pressure washer again for 30 days or more**, follow the instructions for preparing the engine for long-term storage.

⚠ WARNING

Flammable Materials

- **Fuel and its vapors can ignite and cause a fire.** Select a well-ventilated storage area away from sources of heat, flame, or sparks.
- **A hot engine can ignite flammable materials.** Always let engine cool at least five minutes before storing.

Prepare Pressure Washer for Freezing Conditions

If you will be storing the pressure washer in freezing temperatures, you must properly prepare the pressure washer to prevent water from freezing in the system.

⚠ WARNING

Freezing Conditions

Do not allow water to freeze in the pressure washer, high pressure hose, or spray gun. Freezing water can cause damage to the equipment and cause the spray gun to fail in the open position. A spray gun that has failed in the open position can whip around and cause personal injury when the pressure washer is started.

1. Drain the water from the high-pressure hose and spray gun by depressing the trigger on the spray gun until all water drains out.
2. Disconnect the plumbing that connects to the pump outlet.
3. Obtain the materials you will need:
 - 12" piece of garden hose or equivalent, Funnel, and
 - approximately 6 oz. of RV antifreeze.
4. Attach the 12" garden hose piece with the funnel to the pump inlet.
5. Pour RV antifreeze into the funnel, then pull the recoil a few times until antifreeze comes out of the pump outlet.

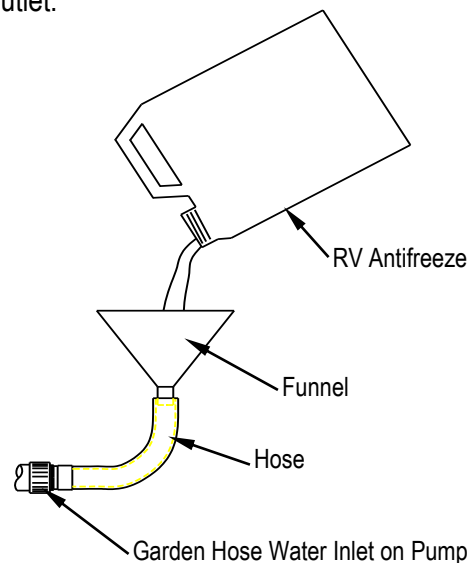

OR

1. Obtain the materials you will need:
 - 1579000 NorthStar Pressure Washer Pump Freeze Guard.
2. Attach bottle of freeze guard to pump inlet.
3. Squeeze freeze guard bottle until antifreeze comes out of the pump outlet.

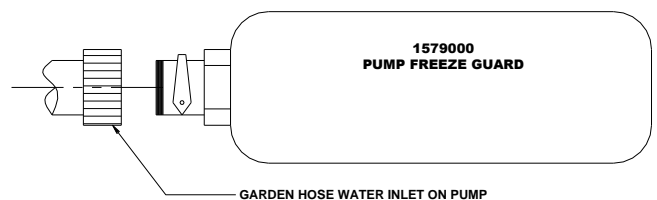

Storage

Prepare Engine for Long Term Storage

First prepare the engine for long term storage if you will not be using the pressure washer for more than 30 days.

Fuel can become stale when stored over 30 days. Stale fuel causes acid and gum deposits to form in the fuel system which can cause malfunction of the engine.

1. Prepare fuel system for storage:
 - **Drain all gasoline** from the tank and carburetor. This is most easily accomplished by *running the pressure washer with the high-pressure hose* until the engine stops from lack of fuel. Drain carburetor bowl after engine has stopped and has been allowed to cool for at least two minutes.

OR

- **Add fuel stabilizer** to the gasoline (following manufacturer's instructions)

Fuel stabilizer steps:

- a. Ensure gas tank is full.
 - b. Add fuel stabilizer to fuel tank.
 - c. *Run pressure washer with high pressure hose* at least 5 minutes after adding stabilizer to allow it to enter the fuel system
 - d. Shut off engine.
2. Lubricate cylinder and piston:
 - a. Disconnect spark plug wire and remove spark plug.
 - b. Add one teaspoon oil through spark plug hole.
 - c. Place rag over spark plug hole and slowly pull the recoil a few times to lubricate the combustion chamber.

Replace spark plug, but do not reconnect the spark plug wire.

Prepare Pressure Washer for Storage

1. Make sure the engine start switch is OFF.
2. Disconnect the engine spark plug wire if you haven't already done so.
3. Disconnect the high-pressure hose, garden hose, and spray gun.

Move Pressure Washer to Storage Location

Let engine cool for 5 minutes before moving the pressure washer to its storage location.

Maintenance & Repair

WARNING

Maintenance Hazards

ALWAYS shut off water supply, bleed water pressure, turn off engine, and disconnect the spark plug wire before cleaning, adjusting, or servicing the pressure washer. After servicing, make sure all guards and cover shields are replaced before using.

Maintenance Schedule Summary

Item	Frequency
Remove dust/debris accumulation	As needed
Inspect fuel system	Each use
Inspect spray system	Each use
Clean inlet filter	Each use
Check engine oil level	Each use
Perform engine maintenance	As specified in engine Owner's manual

See detailed instructions for each maintenance item below.

(Note: For end-of-the-season storage instructions, see the "Storage" section of this manual.)

Detailed Instructions – Maintenance & Repair

No modifications. Never modify or alter the pressure washer in any way. Modifications can create serious safety hazards and will also void the warranty.

Follow Safety Rules

Read and follow these safety rules whenever you will be servicing the pressure washer:

- **Turn off / relieve pressure first.** Always turn off pressure washer and relieve system pressure before inspection or maintenance. Remove spark plug or spark plug wire to prevent accidental starting.
- **Fuel valve off.** Turn fuel shut-off valve to OFF position before transporting or servicing the pressure washer.
- **Replace guards.** Make sure all guards and cover shields are replaced after servicing the pressure washer.
- **Major repair.** Major service, including the installation or replacement of parts, should be performed only by a qualified service technician. Obtain factory approved parts from NorthStar Product Support at 1-800-270-0810.

- **Replacement parts.** If a part needs replacement, only use factory approved repair parts. Replacement parts that do not meet specifications may result in a safety hazard or poor operation of the pressure washer and will void the warranty.

Keep Pressure Washer Clean

If dust or debris accumulates on the pressure washer, clean the pressure washer with a damp cloth or soft bristle brush. Do not allow air intakes to become blocked.

CAUTION

Do not spray pressure washer with a garden hose or pressure washer. Water may enter the pressure washer and cause damage.

Inspect Spray System

Inspect spray system for damage and leaks before each use.

Do not start pressure washer until all needed repairs have been completed.

Maintenance & Repair

⚠ WARNING

High Pressure Fluid Injection Hazard

High pressure fluid discharge from leaks (even pin-sized) or ruptured components can pierce skin and inject fluid into the body. Injection injury can result in blood poisoning and/or severe tissue damage leading to infection, gangrene, and possibly amputation.

- Never use a finger or skin to check for leaks.
 - Never operate pressure washer with damaged or missing hoses/parts.
 - Never attempt to repair a high-pressure hose or component – Always replace it with a part that is rated at or above the pressure rating of this pressure washer.
1. Check hoses, fittings, wand, trigger gun and connections for signs of wear, cracks, looseness, or leaks. Replace as required.
 2. Check and clean the nozzle orifice.

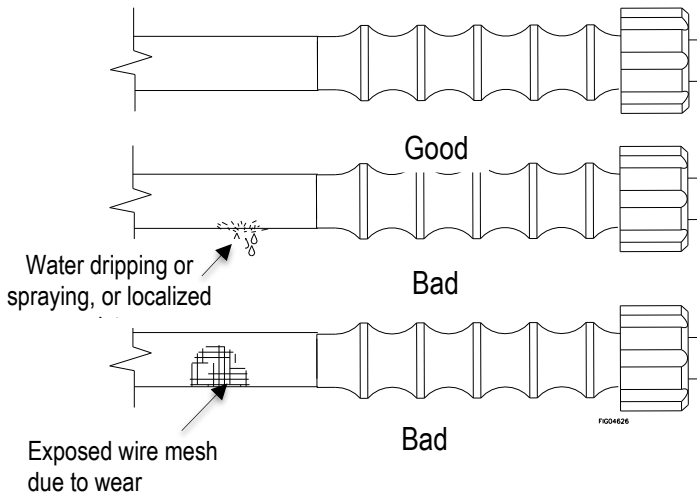

Clean Inlet Filter

Clean the inlet filter before each use.

⚠ WARNING

Filter Disposal

When cleaning filters, check whether dangerous chemicals have been used with the filter and take any precautions that may be recommended by the manufacturer of these chemicals. Always dispose of hazardous fluids per local, state, and national guidelines.

1. Unscrew garden hose from water inlet (if connected).
2. Remove filter screen.
3. Run water through filter screen to clean.
4. Reassemble.

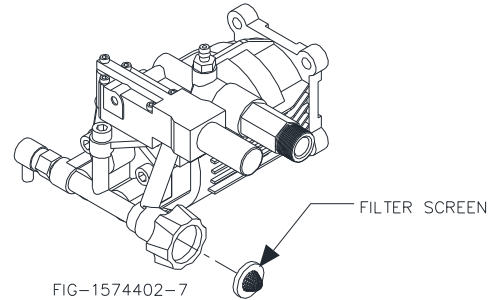

Inspect Fuel System

Inspect the engine fuel system and check for leaks before each use.

Do not start pressure washer until all needed repairs have been completed.

⚠ WARNING

Filter Disposal

Gasoline fuel is highly explosive and fuel leaks can result in fire or explosions. You can be burned and seriously injured if the fuel system is not properly hooked up or there is a fuel leak when you start the engine.

Inspect the entire fuel system. Look for:

- signs of leaks or deterioration
- chafed or spongy fuel hose
- loose connections
- loose or missing fuel hose clamps
- damaged fuel tank
- defective gasoline shut-off valve

Maintenance & Repair

Perform Engine Maintenance

-As specified in the Engine Owner's manual.

Engine maintenance items include:

1. Changing oil and oil filter
2. Air filter check/replacement
3. Spark plug cleaning and replacement
4. Fuel filter check/replacement
5. Inspecting and cleaning muffler (and spark arrestor if equipped)

Contact NorthStar Product Support at
1-800-270-0810 for any
questions, problems, or parts orders.

NOTICE:

Dispose of used motor oil in a manner that is compatible with the environment and in accordance with local, state, and federal laws and regulations.

- Take used oil in a sealed container to your local recycling center or service station for reclamation.
- Do not throw it in the trash, pour it on the ground, or pour it down a drain.

NOTE TO COMMERCIAL USERS:

All mechanical equipment, no matter how well designed, will need maintenance and repairs. A NorthStar pressure washer is no exception. At times, a NorthStar pressure washer may become inoperable because repairs are required. NorthStar Product Support will assist in these repairs as needed, but if an inoperable pressure washer creates a major expense to your business, then we strongly recommend the following:

- Have a staff person become familiar with the mechanical operation of the pressure washer and capable of making minor repairs and performing all preventative maintenance procedures.
- Keep a stock of recommended service parts for maintenance and minor repairs.

IMPORTANT: Replacement Parts

If a part needs replacement, only use parts that meet the manufacturer's part number specifications. Replacement parts that do not meet specifications may result in a safety hazard or poor operation of the pressure washer.

Troubleshooting

This section provides a list of the more frequently encountered pressure washer malfunctions, their causes, and corrective actions. Some corrective actions can be performed by the operator or maintenance personnel, and others may require assistance of a qualified Service Center.

ENGINE WILL NOT START	
<i>Causes</i>	<i>Solutions</i>
Low oil shutdown	Fill engine with the adequate amount of oil
Cold engine	Choke engine to start
No fuel	Add gas to fuel tank. Make sure fuel shutoff valve is open
Pressure build-up from initial use	Trigger spray gun to relieve pressure
Engine not turned ON	Place ON/OFF switch in the ON position
Spark plug wire not attached	Attach spark plug wire to spark plug
LOW/SURGING PRESSURE	
<i>Causes</i>	<i>Solutions</i>
Insufficient water supply	Increase water flow, check for kinked or pinched hose
Plugged inlet screen	Pull out and clean screen carefully
Need to use high pressure nozzle	Change to the green, yellow, white, or red nozzle
Plugged nozzle	Remove nozzle, check for blockage
Worn nozzle	Replace nozzle
Leak in high pressure line	Fix leaks
NO CHEMICAL INJECTION	
<i>Causes</i>	<i>Solutions</i>
Need to use different nozzle	Change to the black nozzle
Back pressure from extra-long hose	Try shorter high-pressure hose
Leak in clear chemical hose	Replace hose. Use hose clamps if necessary
Chemical strainer not submerged	Make sure strainer is completely submerged in solution

Parts Explosion- Model #1574402, 1574403

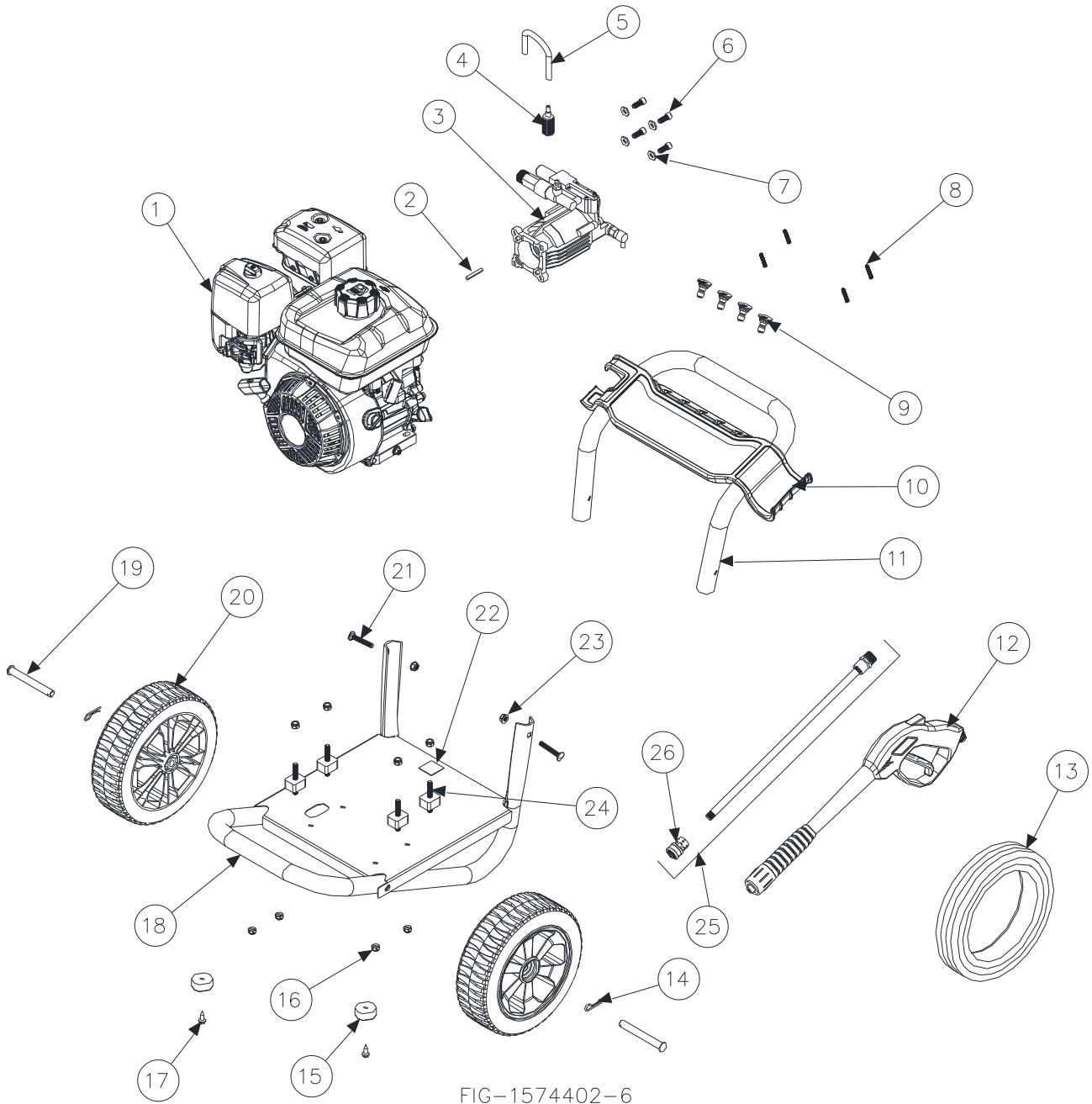

FIG-1574402-6

***1574402 SHOWN**

Parts List - Model #1574402, 1574403

REF#	PART#	DESCRIPTION	QTY	MODEL#
1	803644	ENGINE-BRIGGS CR950	1	1574402
	803645	ENGINE-BRIGGS XR1150		1574403
2	82141	KEY, SHAFT 3/16 X 1.5	1	ALL
3	803771	PUMP, V-PW29/2.6	1	ALL
4	221222	CHEMICAL STRAINER	1	ALL
5	777165	BRAIDED CHEMICAL HOSE	2 FT	ALL
6	82306	BOLT, SHCS 5/16-24 X 3/4	4	ALL
7	82047	WASHER, M8 FLAT	4	ALL
8	803750	SCREW, DTS #10-16x1-1/4"	4	ALL
9	800110	NOZZLE 4 PACK, #3.0	1	ALL
10	803988	BILLBOARD WITH DECAL	1	ALL
11	803651	HANDLE TUBE	1	ALL
12	38526	SPRAY GUN, 2700PSI, 22MM	1	ALL
13	780841	HOSE, 1/4"X25" 3000PSI W/22MM	1	ALL
14	30312	COTTER PIN	2	ALL
15	2215	RUBBER FOOT	2	ALL
16	777495	NUT, NYLOCK M8-1.25	8	ALL
17	82232	SCREW, SELF TAP 1/4 X 3/4	2	ALL
18	803653	PRESSURE WASHER CART	1	ALL
19	803674	CLEVIS PIN, AXLE 1/2	2	ALL
20	803672	TIRE, 10" FLAT FREE	2	ALL
21	82233	BOLT, CARRIAGE GR5Z 5/16-18X2	2	ALL
22	801058	DECAL, MADE IN USA	1	ALL
23	82630	NUT, FLANGE NYLOCK 5/16"	2	ALL
24	795564	ISO MOUNT, M8	4	ALL
25	803669	LANCE	1	ALL
26	791308	NOZZLE QUICK COUPLER	1	ALL

Pump Exploded View - 803771

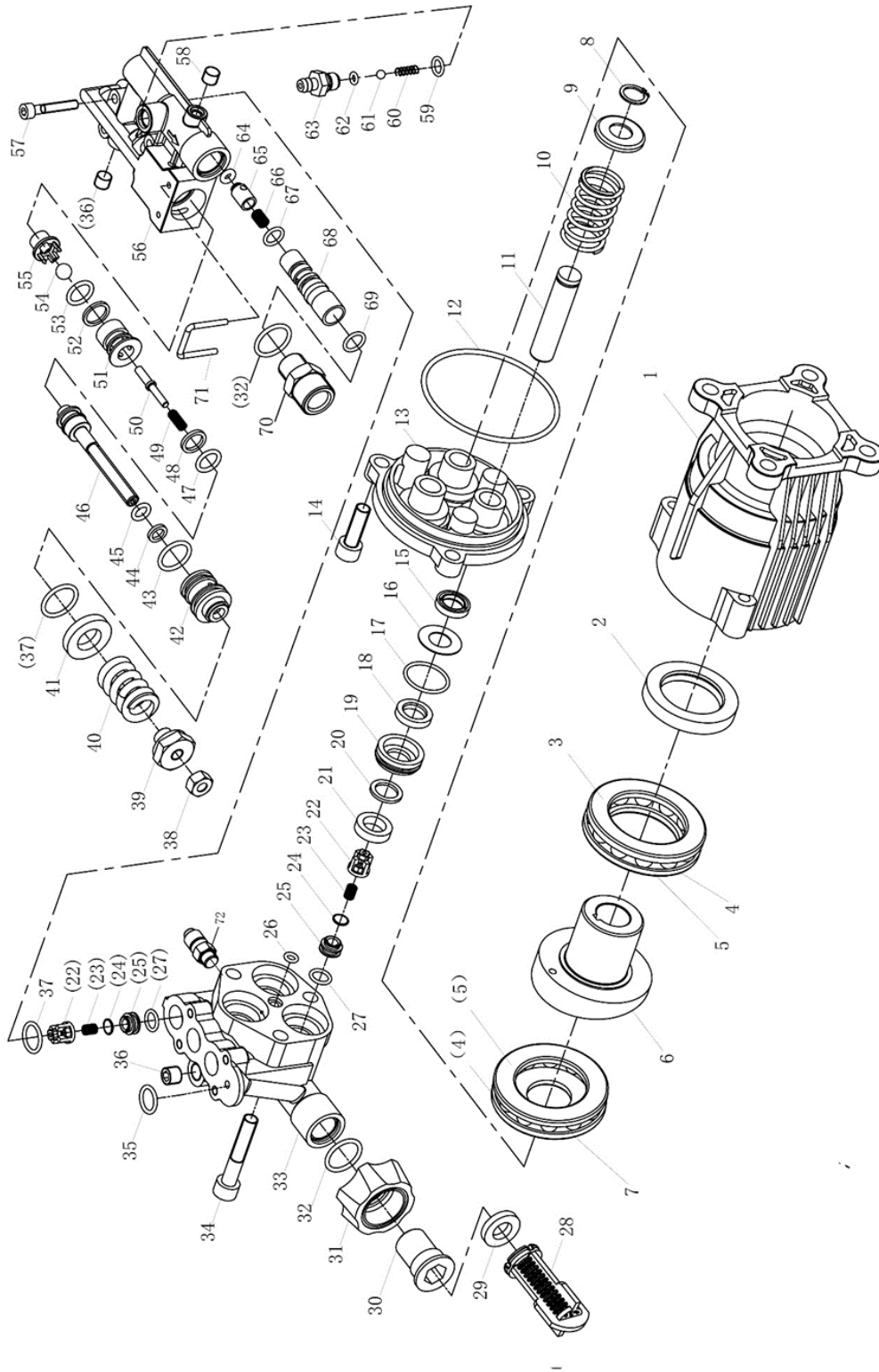

Pump Parts List – 803771

REF#	KIT NUMBER	DESCRIPTION	QTY
1	Not Available	Swashplate Box	1
2	Not Available	Oil sealB35528	1
3	Not Available	Bearing 2	2
4	Not Available	Holding frame Assy. 2	2
5	Not Available	Bearing 3	1
6	Not Available	Swashplate	1
7	Not Available	Bearing 1	1
8	Not Available	Retaining ring 12	3
9	Not Available	Clamp	3
10	Not Available	Back spring	3
11	Not Available	Plunger	3
12	Not Available	O-ring 73X2.65	1
13	Not Available	Plunger base	1
14	Not Available	Screw M8X25 10.9	4
15	Kit #1	Reciprocating oil seal TC4/12X20X6	3
16	Kit #1	Cushion	3
17	Kit #1	O-ring22.4X1.8	3
18	Kit #1	ROY/12X20X4	3
19	Kit #1	Auxiliary sealing ring	3
20	Kit #1	Water seal gasket	3
21	Kit #1	Water seal ROY / 12 x18x4	3
22	Kit #2	Valve bonnet	6
23	Kit #2	Inlet and Outlet Valve Spring	6
24	Kit #2	Inlet and Outlet Valve Gasket	6
25	Kit #2	Valve seat	6
26	Kit #2	O-ring 4.5X1.8	1
27	Kit #2	O-ring 9x1.8	6
28	Kit #5	Inlet strainer	1
29	Kit #5	Rubber gasket	1
30	Kit #5	Water supply connector	1
31	Kit #5	Hand nut	1
32	Kit #5 and Kit #3	O-ring 14X1.8	2
33	Not Available	Pump Head	1
34	Not Available	Screw M8X45 12.9	3
35	Kit #2 and Kit #4	O-ring 12	1
36	Kit #4	R2 1/8 laryngeal plug-8.8	2
37	Kit #2 and Kit #4	O-ring 14	4
38	Kit #4	Nut M6/ galvanized	1
39	Kit #4	Pressure adjusting nut	1
40	Kit #4	Pressure adjusting spring	1
41	Kit #4	Maintaining washer	1
42	Kit #4	Valve sleeve	1

REF#	KIT NUMBER	DESCRIPTION	QTY
43	Kit #4	O-ring 12.42X1.78	1
44	Kit #4	Closing retainer 6.2 x9x1.25	1
45	Kit #4	O ring 6.07X1.78	1
46	Kit #4	Valve rod	1
47	Kit #4	O-ring 8.5X1.8	1
48	Kit #4	Open retaining ring 8.7X11.6X1.25	1
49	Kit #4	Top pin spring	1
50	Kit #4	Apex pin	1
51	Kit #4	Upper seat	1
52	Kit #4	Opening retainer 10.3 x13 x1.25	1
53	Kit #4	O-ring 10x1.8	1
54	Kit #4	Steel ball 7/9Cr18	1
55	Kit #4	Base	1
56	Kit #4	Outlet Valve Body	1
57	Not Available	Screw M5X30 12.9	5
58	Kit #4	Plug R1/16	1
59	Kit #3	O-ring 7.65X1.78	1
60	Kit #3	Suction spring	1
61	Kit #3	Steel ball 3/16"	1
62	Kit #3	O-ring 3.68X1.78	1
63	Kit #3	Pipette tip	1
64	Kit #3	O-ring 4X2.65	1
65	Kit #3	Check spool	1
66	Kit #3	Backstop spring	1
67	Kit #3	O-ring 9X1.8	2
68	Kit #3	Venturi	1
69	Kit #3	O-ring 10X1.8	1
70	Kit #3	Short outlet joint	1
71	Kit #4	U-shaped pin	1
72*	Kit #6	Thermal protector	1

* Ref item#72 not shown in the pump exploded view image.

Pump Parts List – 803771

KIT #	DESCRIPTION	ITEM #	ITEMS INCLUDED	QTY	KIT PART #	KIT QTY
1	Seal Kit	15	Reciprocating oil seal TC4/12X20X6	3	801743	1
		16	Cushion	3		
		17	O-ring 22.4X1.8	3		
		18	ROY/12X20X4	3		
		19	Auxiliary sealing ring	3		
		20	Water seal gasket	3		
		21	Water seal ROY / 12 x18x4	3		
2	Valve Kit	22	Valve bonnet	6	801744	1
		23	Inlet and Outlet Valve Spring	6		
		24	Inlet and Outlet Valve Gasket	6		
		25	Valve seat	6		
		26	O-ring 4.5X1.8	1		
		27	O-ring 9x1.8 (Shore hardness 80)	6		
		35	O-ring 12 (inner diameter) X2	1		
3	Outlet Kit w/ Injector	37	O-ring 14 (inside diameter) X2	4	801745	1
		59	O-ring 7.65X1.78	1		
		60	Suction spring	1		
		61	Steel ball 3/16"(0Cr18Ni9)	1		
		62	O-ring 3.68X1.78	1		
		63	Pipette tip	1		
		64	O-ring 4X2.65	1		
		65	Check spool	1		
		66	Backstop spring	1		
		67	O-ring 9X1.8	2		
		68	Venturi	1		
		69	O-ring 10X1.8	1		
		32	O-ring 14X1.8	2		
4	Unloader Manifold Kit	70	Short outlet joint	1	801746	1
		35	O-ring 12 (inner diameter) X2	1		
		37	O-ring 14 (inside diameter) X2	4		
		38	Nut M6/ galvanized	1		
		39	Pressure adjusting nut	1		
		40	Pressure adjusting spring	1		
		41	Maintaining washer	1		
		42	Valve sleeve	1		
		43	O-ring 12.42X1.78(shore hardness 90)	1		
		44	Closing retainer 6.2 x9x1.25	1		
		45	O ring 6.07X1.78(shore hardness 90)	1		
		46	Valve rod	1		
		47	O-ring 8.5X1.8 (Shaw hardness 90)	1		
		48	Open retaining ring 8.7X11.6X1.25	1		
		49	Top pin spring	1		
		50	Apex pin	1		
		51	Upper seat	1		
		52	Opening retainer 10.3 x13 x1.25	1		
		53	O-ring 10x1.8 (shore hardness 90)	1		
		54	Steel ball 7/9Cr18	1		
55	Base	1				
56	Outlet Valve Body (Metal Processing)	1				
36	R2 1/8 laryngeal plug-8.8	1				
58	Plug R1/16	1				
71	U-shaped pin	1				
5	Inlet Kit	28	Inlet strainer	1	801747	1
		29	Rubber gasket	1		
		30	Water supply connector	1		
		31	Hand nut	1		
		32	O-ring 14X1.8	1		
6	Thermal Relief	72	Thermal protector	1	801748	1

Limited Warranty

Dear Valued Customer:

The NorthStar Product you just purchased is built with the finest material and craftsmanship. Use this product properly and enjoy the benefits from its high performance. By purchasing a NorthStar product, you show a desire for quality and durability. Like all mechanical equipment this pressure washer requires a due amount of care. Treat this pressure washer like the high-quality piece of machinery it is. Neglect and improper handling may impair its performance. Please thoroughly read the instructions and understand the operation before using your product. Always contact NorthStar Product Support at 1-800-270-0810 prior to having any service or warranty work performed, as some services performed by parties other than NorthStar approved service centers may void this warranty. This warranty is in lieu of any other warranty expressed or implied and NorthStar assumes no other responsibility or liability outside that expressed within this warranty.

Limited Warranty

NorthStar shall warranty any piece of equipment manufactured, or parts of equipment manufactured, to be free from defects in material or workmanship for a period of:

Item Number	Item Name	Commercial Warranty	Consumer Warranty	Details
ALL	NorthStar	5 years from date of purchase	5 years from date of purchase	NorthStar shall warrant structural components from failure for a period of 5 years from the date of purchase by user. Structural parts include but are not limited to, cart, handle, billboard and bumper tube
ALL	Pump	2 years from date of purchase	2 years from date of purchase	NorthStar shall warrant the pressure washer pump to be free of defects in material and workmanship for a period of 2 years. NorthStar makes no warranty on standard wear items such as, but not limited to, seals, valves, seats, O-rings and pistons.
ALL	Briggs & Stratton	3 years from date of purchase	3 years from date of purchase	The engine warranty is covered under the terms and conditions as outlined by the engine manufactures warranty and is the sole responsibility of the engine manufacture. Normal engine maintenance such as spark plugs, air filters, adjustments, fuel system cleaning and obstruction due to build up is not covered by this NorthStar warranty.
ALL	Normal Wear Items	90 days from date of purchase	90 days from date of purchase	In addition to the normal warranty, NorthStar shall warrant any normal wear item from defects in material or workmanship for a period of 90 days from the date of purchase by user. Normal wear items include, but are not limited to, nozzles, quick connect fittings, valves, high- pressure hoses, o-rings, filter elements, gun, lance, tires, and unloader valves

“Consumer use” means personal residential household use by a consumer. “Commercial use” means all other uses, including use for commercial, income producing or rental purposes or when purchased by a business.

This warranty applies to the original purchaser of the equipment (verification of purchase, in the form of a receipt, is the responsibility of the buyer), is non-transferable, and covers parts and labor. Parts will be replaced or repaired at no charge, except when the equipment has failed due to lack of proper maintenance. If a part is no longer available, the part may be replaced with a similar part of equal function. Any misuse, abuse, alteration or improper installation or operations will void warranty. Determining whether a part is to be replaced or repaired is the sole decision of NorthStar. NorthStar will not provide for replacement of complete products due to defective parts. Any costs incurred due to replacement or repair of items outside of a NorthStar approved facility is the responsibility of the buyer and not covered under warranty. Transportation costs to and from service center is the responsibility of the customer.

This warranty specifically excludes the following; failure of parts due to damage caused by accident, fire, flood, windstorm, acts of God, applications not approved by NorthStar in writing, corrosion caused by chemicals, use of replacement parts which do not conform to manufacturer’s specifications, damage related to rodent and/or insect infestation and damage caused by vandalism. Additional exclusions: loss of running time, inconvenience, loss of income, or loss of use, including any implied warranty of merchantability of fitness for a specific use. Also, Outdoor Power Equipment needs periodic parts and service to perform well, and this warranty does not cover instances when normal use has exhausted the life of a component or the engine.

This warranty does not cover any personal injury or damage to surrounding property caused by failure of any part. Repair or replacement of parts does not extend the warranty period.

Limited Warranty Continued

The engine warranty is covered under the terms and conditions as outlined by the engine manufactures warranty contained herein and is the sole responsibility of the engine manufacture. Normal engine maintenance such as spark plugs, air filters, adjustments, fuel system cleaning and obstruction due to build up is not covered by this NorthStar warranty.

Please fill in the following information and have it on hand when you call in on a warranty claim.

Customer Number: _____

Date of Purchase: _____

NorthStar Serial Number: _____

Item Number: _____

⚠ WARNING: This product can expose you to chemicals including gasoline engine exhaust, which is known to the State of California to cause cancer, and carbon monoxide, which is known to the State of California to cause birth defects or other reproductive harm.

For more information go to www.P65Warnings.ca.gov.



Assembled by
Northern Tool & Equipment Company, Inc.
Burnsville, MN 55306
NorthernTool.com