



# M1574210I

ITEM NUMBER: 1574210, 1574211,  
1574212, 1574213  
SERIAL NUMBER: \_\_\_\_\_

## Owner's Manual Electric Hot Water/Steam Pressure Washer

### Portable Outdoor – Use Only

This pressure washer produces both cold and hot water high-pressure spray as well as wet steam. Cleaning chemicals may be incorporated into the spray if desired. The pressure pump for this equipment is powered by an electric motor and the water is heated by a diesel, kerosene/fuel-oil fired, down draft burner.

#### **WARNING: SPECIAL HAZARDS**

- **Skin/Eye Injury:** High-pressure spray can cause serious skin or eye injury, including injection injury if fluid pierces the skin. Injection injury can result in blood poisoning and/or severe tissue damage.
- **Burns:** Hot spray can scald and burn skin. Hot surfaces of wand and burner, as well as hot exhaust from the burner can cause burns.
- **Slips/Falls:** Spray discharge can cause puddles and slippery surfaces. Spray-gun kickback can cause operator loss of balance and falls.
- **Flying Debris:** High-pressure spray can cause surface damage and flying debris.
- **Fire/Explosion:** Burner sparking can ignite fuel or other flammable liquids or vapors in the vicinity. Hot exhaust from burner can ignite combustible materials.
- **Chemical Exposure:** Cleaning chemical vapors or contact with skin may be hazardous.
- **Electric shock:** Spray contact with electrical sources can cause electric shock.
- **Electrocution:** Improper connection of the equipment or grounding conductor can result in a risk of electrocution.
- **CO Poisoning:** Exhaust from burner contains carbon monoxide, a poisonous gas that can cause carbon monoxide poisoning and possible death if inhaled.

### Equipment Protection Quick Facts

**Inspect Upon Delivery:** STOP! Closely inspect to make sure no components are missing or damaged. For missing or damaged components please contact Product Support at 1-800-270-0810.

**Check Pump Oil:** Pump is shipped with oil. Check pump oil level before starting.

- Remove shipping tape and black vent plug (if present) from pump oil fill cap (CAT Pumps)
- Pump is supplied with Vented fill cap (General Pumps only)

**Water Flow Requirements:** Make sure your supply water flow rate is 20% higher than the pressure washer's flow rate (See Specification Section for unit specific flow rates), and that your water is clean and particle free.

**Chemical Spraying:** Use only NorthStar brand or equivalent washer chemicals designed for pressure washer use.

**Maintenance Schedule:** Pump, burner fuel filter, burner coil and electrodes require periodic checking and servicing to keep pressure washer functioning efficiently. See "*Maintenance & Repair*" for frequency of servicing.

**Any Questions, Comments, Problems or Parts Orders**

**Call NorthStar Product Support 1-800-270-0810**

# Table of Contents

Equipment Protection Quick Facts .....	1
<b>TABLE OF CONTENTS</b> .....	<b>2</b>
<b>ABOUT YOUR PRESSURE WASHER</b> .....	<b>4</b>
<b>SPECIFICATIONS</b> .....	<b>5</b>
<b>COMPONENT IDENTIFICATION</b> .....	<b>6</b>
<b>SPECIAL EQUIPMENT SAFETY FEATURES</b> .....	<b>8</b>
High Pressure Safety Device (Rupture Disc) .....	8
Temperature Sensor .....	8
Spray Gun Safety Latch .....	8
High Pressure Limit Switch .....	8
<b>SAFETY</b> .....	<b>9</b>
Hazard Signal Word Definitions .....	9
<b>SAFETY DECAL LOCATIONS</b> .....	<b>10</b>
<b>ASSEMBLY AND INITIAL SET-UP</b> .....	<b>11</b>
<b>Step 1. Inspect &amp; Unpack</b> .....	<b>11</b>
<b>Step 2. Assembly</b> .....	<b>11</b>
<b>Step 3. Initial Pump &amp; Motor Preparation</b> .....	<b>11</b>
Prepare Water Pump .....	11
<b>Step 4. Verify Electrical Connection</b> .....	<b>12</b>
Grounding .....	12
Ground Fault Circuit Interrupter Protection .....	12
Extension Cord .....	12
<b>Step 5. Moving and Handling</b> .....	<b>13</b>
Moving your pressure washer around .....	13
<b>BEFORE EACH USE</b> .....	<b>14</b>
<b>Step 1: Inspect Equipment</b> .....	<b>14</b>
Electrical .....	14
Pump Oil .....	14
Spray System .....	14
Burner Fuel System (if heated water to be used) .....	14
Periodic Maintenance .....	14
<b>Step 2. Check and Fill Burner Fuel Tank</b> .....	<b>14</b>
Filling Burner Fuel Tank (if heated water to be used) .....	15
<b>Step 3. Select Suitable Worksite Guidelines</b> .....	<b>15</b>
For All Indoor and Outdoor Uses .....	15
For Indoor Hot Water/Burner Use .....	15
<b>OPERATION</b> .....	<b>17</b>
<b>Step 1. Connect Hoses, Water Supply, and Spray Nozzle</b> .....	<b>17</b>
Attach Garden Hose to Water Supply .....	17
Check Water Supply .....	17
Connect Water Supply to Pump .....	17
Connect Pressure Hose to Pump .....	17
Quick Connect Procedure .....	17
Select Spray Nozzle .....	17
Attach Nozzle to Spray Gun .....	18
<b>Step 2. Pre-Spraying Procedure</b> .....	<b>18</b>
Safety Rules .....	18
Personal Protective Gear .....	19
Purging .....	19

<b>Step 3. Spraying</b> .....	<b>19</b>
Starting .....	19
Spraying Procedure .....	19
Using Chemicals for Cleaning (if desired).....	19
Hot Spray Procedure .....	21
<b>Step 4. Stopping</b> .....	<b>21</b>
<b>STORAGE</b> .....	<b>22</b>
Between-Use Storage.....	22
Long-Term Storage Preparation (between infrequent uses and at end of season).....	22
Winter Storage Preparation .....	22
<b>MAINTENANCE &amp; REPAIR</b> .....	<b>24</b>
<b>MAINTENANCE SCHEDULE</b> .....	<b>24</b>
<b>DETAILED INSTRUCTIONS – MAINTENANCE &amp; REPAIR</b> .....	<b>24</b>
Dust/Debris Removal .....	24
Inspect Fuel System(s).....	24
Inspect Spray System.....	24
Clean Inlet Filter for Garden Hose .....	25
Check Tire Pressure .....	25
Change Pump Oil.....	25
Drain Burner's Fuel Filter/Water Separator.....	25
Descale Heating Coil .....	25
Inspect and clean the flow switch as needed.....	27
Inspect Heating Coil and Desoot as Needed.....	28
Inspect/Clean/Adjust Electrodes.....	29
Perform Engine Maintenance .....	30
<b>OIL BURNER ADJUSTMENT (ONLY NEEDED IF WHITE EXHAUST SMOKE APPEARS)</b> .....	<b>31</b>
<b>TROUBLESHOOTING</b> .....	<b>32</b>
<b>MAJOR COMPONENTS</b> .....	<b>34</b>
<b>PARTS EXPLOSION: FRAME</b> .....	<b>35</b>
<b>PARTS LIST: HEAT EXCHANGER</b> .....	<b>39</b>
<b>PARTS EXPLOSION: ACCESSORIES: - GUN, HOSE, CHEMICAL INJECTOR</b> .....	<b>44</b>
<b>PUMP EXPLODED-GP PUMP</b> .....	<b>45</b>
<b>PUMP EXPLOSION-CAT 4DX</b> .....	<b>48</b>
<b>PUMP EXPLODED VIEW – GP EP1812 PUMP</b> .....	<b>52</b>
<b>PUMP PARTS LIST – GP EP1812 PUMP</b> .....	<b>53</b>
<b>PUMP PARTS LIST – GP EP1812 PUMP</b> .....	<b>54</b>
<b>WIRING DIAGRAM - 1574210</b> .....	<b>55</b>
<b>WIRING DIAGRAM - 1574211</b> .....	<b>56</b>
<b>WIRING DIAGRAM – 1574212 &amp; 13</b> .....	<b>57</b>
<b>SUMMARY OF IMPORTANT SAFETY INFORMATION</b> .....	<b>58</b>
<b>LIMITED WARRANTY</b> .....	<b>63</b>
<b>CALIFORNIA PROPOSITION 65 INFORMATION</b> .....	<b>64</b>

## About Your Pressure Washer

Thank you for purchasing a NorthStar hot water pressure washer! It is designed for long life, dependability, and top performance.

**Intended Use.** Washing siding, windows, walkways, driveways, patios, decks, fences, vehicles, boats, lawnmowers, ATVs and other equipment by:

- Producing a high-pressure water spray (heated or unheated).
- Incorporating cleaning chemicals into a low-pressure water spray.

Note: Do not use for other purposes, as unforeseen hazards or equipment damage may result.

**Water Supply.** The pump requires a clean, standard tap water supply provided through a garden hose at a flow rate 20% higher than the pressure washers flow rate. Use of a backflow preventer on the water supply hose is recommended and may be required by local code.

**Chemical Usage.** Any cleaning chemicals that are used must be specifically approved for use in pressure washers.

**Power Source.** The pump is powered by an electric motor. The spray water is heated (when desired) by a diesel, kerosene/ fuel oil fired, spark-ignited, down draft burner.

**Supplies Required.** Normal operation will require you to supply:

- Electric supply
- Personal Protection Equipment
- Pump Oil
- Fuel for the burner (diesel, kerosene, or fuel oil)

See “*Specifications*” section of this manual for more detail.

**Site Selection.** Pressure washers used while the open flame burner is used to heat the water are for **OUTDOOR USE ONLY** unless specific exhausting guidelines are met. Read additional details in the “*Before Each Use*” section of this manual.

**Personal Protection.** Wear safety apparel during operation, including waterproof insulated gloves, safety glasses with side and top protection, and non-slip protective footwear. Some cleaning chemicals may require the use of a respirator mask (as instructed on chemical label).

**Adult control only.** Only trained adults should set up and operate the pressure washer. Do not let children operate. Pressure washers can generate forces greater than children can control and require judgment beyond what can be expected of them.

**Under The Influence.** Never operate, or let anyone else operate, the pressure washer while fatigued or under the influence of alcohol, drugs, or medication.

Keep this manual for reference and review. A summary of important safety information can be found at the end of the manual.

Proper preparation, operation, and maintenance of this pressure washer will result in optimal performance and a long life for this equipment. For detailed Motor operation and maintenance information, always refer to the Motor Owner’s Manual furnished with the pressure washer.

### **ATTENTION: Rental Companies and Private Owners who loan this equipment to others!**

All persons to whom you rent/loan this pressure washer must have access to and read this manual. Keep this owner’s manual with the pressure washer at all times and advise all persons who will operate the machine to read it. You must also provide personal instruction on how to safely set-up and operate the pressure washer and remain available to answer any questions a renter/borrower might have. Owner’s Manuals are available from NorthStar at 1-800-270-0810.

## Specifications

MODEL				
Model #	1574210	1574211	1574212	1574213
FLOW OUTPUT				
Pressure Rating	1700 psi	2000 psi	2750 psi	2000 psi
Flow Rate	1.5 gpm	1.5 gpm	2.5 gpm	4.0 gpm
Minimum Water Supply Flow Rate	1.8 gpm	1.8 gpm	3.0 gpm	4.8 gpm
Maximum Temperature	250° F			
MOTOR				
Dedicated NEMA Receptacles	NEMA-5-20R	NEMA-5-20R	NEMA-6-30R	NEMA-6-30R
Motor Horsepower	1.5HP	2.0HP	5.0HP	6.2HP
Amps	20A	20A	30A	30A
Volts	120V	120V	240V	240V
DIMENSIONS/COMPONENTS				
Length	46"			
Width	32"			
Height	38"			
Weight (fueled)	367 lbs.	369 lb.	417 lb.	451 lb.
Pump Model	GP EVO	Cat 4DX	CAT 4DNX	GP EP1812
Pump Oil Capacity	4.7 oz	8.5 oz	8.5 oz	15.0 oz
Nozzle Orifice Size	#2.0	#2.0	#3.0	#5.5
SUPPLIES REQUIRED (not included)				
Burner Fuel	#1 or #2 Diesel, B5 or lower Biodiesel, Kerosene, or Fuel Oil (Capacity: 5 gal.)			
Pump Oil (shipped with oil, but refills required)	SAE 30 Non-Detergent Oil or Pressure washer Pump Oil (Part# 4043)	SAE 30 Non-Detergent Oil or Cat Pump Oil (Part# 22158)	SAE 30 Non-Detergent Oil or Cat Pump Oil (Part# 22158)	SAE 30 Non-Detergent Oil or Pressure washer Pump Oil (Part# 4043)
Input Water Supply	Standard tap water @ 20-75 psi, delivered @			
	1.8 gpm	1.8 gpm	3.0 gpm	4.8 gpm
Input Water Supply Hose	Standard garden hose with inside diameter at least 5/8" (at least 3/4" diameter if hose longer than 100 ft.)			

# Component Identification

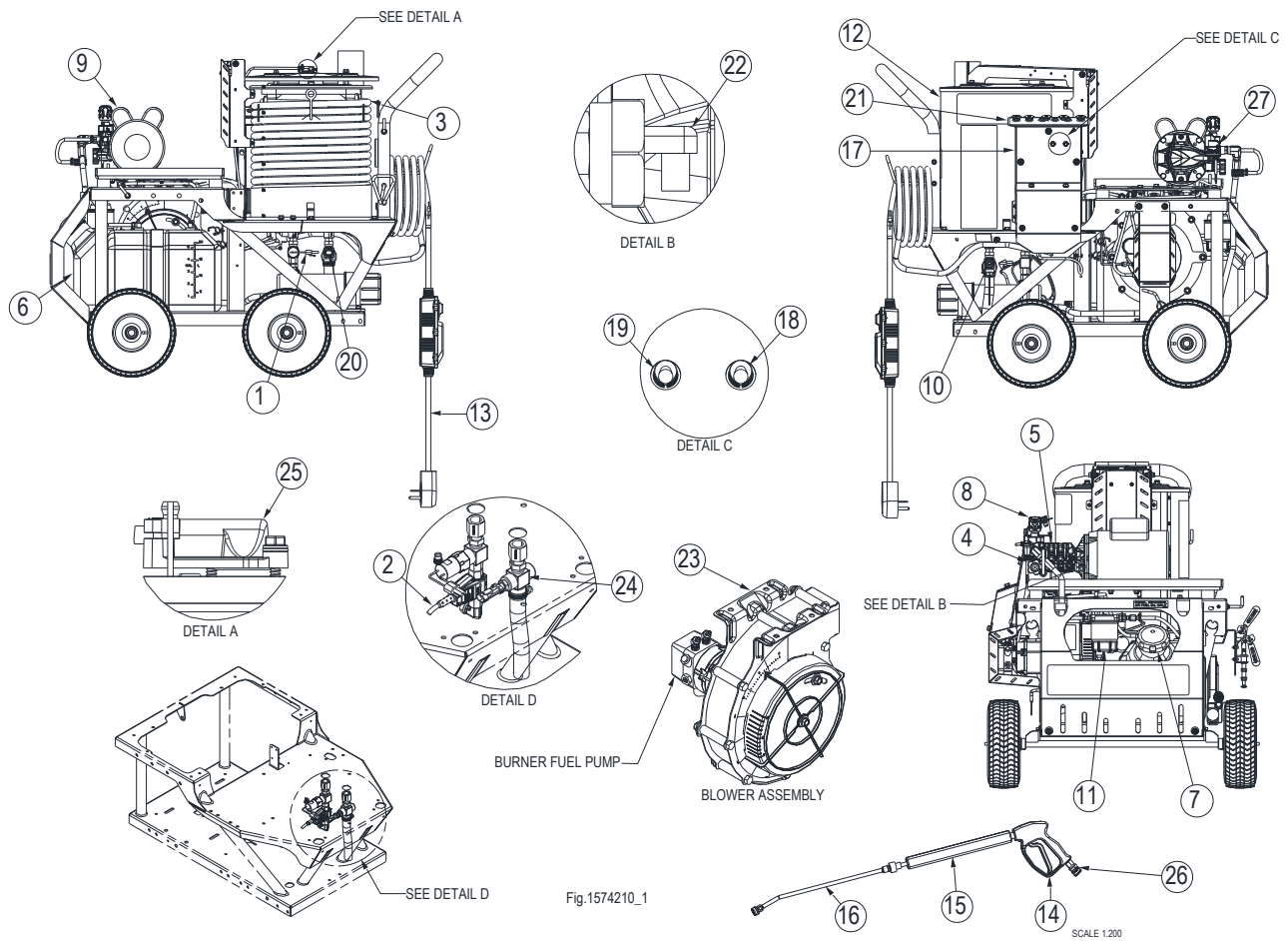

Ref #	Description	Ref #	Description	Ref #	Description
1	High PSI limit switch	10	High Pressure Outlet	19	Heat Switch
2	Flow Switch	11	Fuel Filter/Water Separator	20	Temperature Sensor
3	Heating Coil	12	Heat Exchanger	21	Nozzle Storage
4	Garden Hose Water Inlet	13	GFCI Cord	22	Thermal Relief Valve
5	Pump	14	Spray Gun	23	Blower Assembly
6	Diesel Fuel Tank	15	Grip	24	Rupture Disc Fitting
7	Diesel Fuel Cap	16	Wand	25	Flame Sensor
8	Unloader	17	Control Box (See Detail A)	26	Quick Connector
9	Motor	18	Power Switch	27	Total Start/Stop Switch

## Component identification

1. **High, PSI limit switch:** This is a backup safety feature, if the system pressure exceeds the set pressure this device will stop the burner from firing.
2. **Flow Switch:** Mechanical device that senses water flow.
3. **Heating Coil:** Steel piping wound together with an inlet for incoming cold water and outlet for hot water to exit.
4. **Garden Hose Water Inlet:** Connection point for standard garden hose. Garden hoses less than 100' in length must have a minimum inner diameter of 5/8." Garden hoses over 100' in length must have a minimum inner diameter of 3/4."
5. **Pump:** A device that moves fluid through a combination of suction and displacement.
6. **Diesel Fuel Tank:** Fuel storage container for diesel fuels.
7. **Diesel Fuel Cap:** Vented cover for fuel tank.
8. **Unloader:** Valve that regulates pressure and directs flow into bypass when trigger is closed.
9. **Motor:** Electric motor powers the pump.
10. **High Pressure Outlet:** Connection point for the high-pressure hose.
11. **Fuel Filter / Water Separator:** Filter in fuel line that removes water and screens out dirt and debris from fuel.
12. **Heat Exchanger:** Device that heats the water by forcing a flame across steel pipe.
13. **GFCI Cord:** Device provides additional protection from the risk of electric shock.
14. **Spray Gun:** Used to divert water out to nozzle.
15. **Grip:** Section of wand to extend length and provide stability.
16. **Wand:** Rod to extend length.
17. **Control Box:** Housing device for mounting switches and machine controls.
18. **Power Switch:** Device for protecting circuit from damage if overloaded or shorted.
19. **Heat Switch:** Control Device that limits the water temperature.
20. **Temperature Sensor:** Control Device that limits the water temperature.
21. **Nozzle Storage:** A space for storing nozzles.
22. **Thermal Relief Valve:** Valve protects pump from overheating.
23. **Blower Assembly:** System provides air, fuel, and ignition for combustion.
24. **Rupture Disc:** Safety device that will open and relieve excess system pressure.
25. **Flame Sensor:** Device for sensing if the burner has a flame.
26. **Quick Connector:** Connection point on spray gun for high pressure hose.
27. **Total Start/Stop Switch:** Automatically shuts motor off when not spraying.

Note: See "Parts Explosion" for additional detail.

# Special Equipment Safety Features

This unit is equipped with the following safety features:

## High Pressure Safety Device (Rupture Disc)

Acts as a backup safety feature. If the Pressure Control Valve (Unloader) malfunctions, this separate high-pressure safety device will open and relieve excess system pressure. Repair is required.

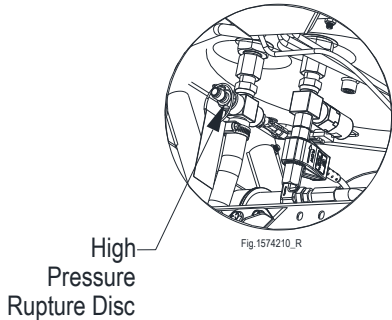

**⚠ WARNING: Rupture Disc failure**  
 If the high-pressure safety device ever discharges water, turn the motor off and do not use the machine. Call Product Support at 1-800-270-0810.

## Temperature Sensor

Measures water temperature and automatically turns burner off when temperature setting is reached. When water temperature drops, burner automatically reignites.

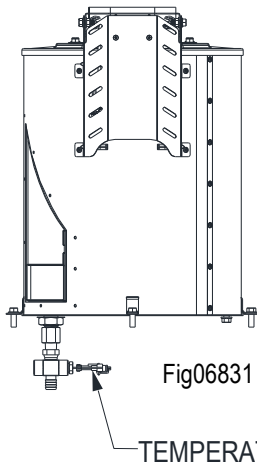

## Pump Thermal Relief Valve

This unit is equipped with a thermal relief valve to protect the pump from overheating. The pump continues to work in bypass mode when you are not spraying. If high temperatures are developed during bypass mode, the thermal relief valve will open and discharge hot water onto the ground, protecting the

pump from overheating. The thermal relief valve is located on the pump manifold's low-pressure port.

## Spray Gun Safety Latch

Has a built-in trigger safety latch to guard against

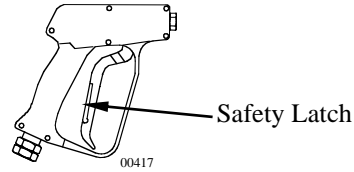

accidental trigger actuation.

## High Pressure Limit Switch

Acts as primary safety feature. If the system pressure exceeds the set pressure limit this device will stop the burner from firing.

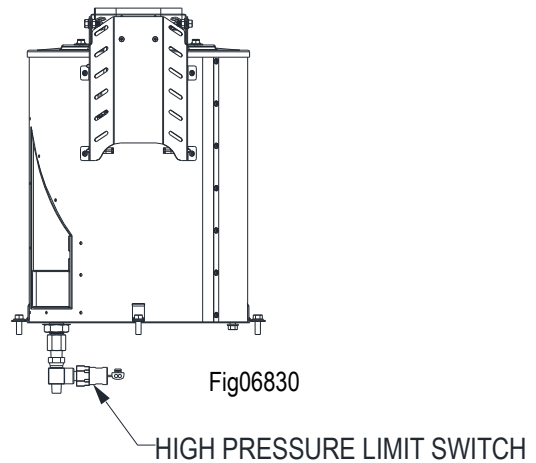

# Safety

## Hazard Signal Word Definitions



This is the safety alert symbol. It is used to alert you to potential personal injury hazards. Obey all safety messages that follow this symbol to avoid possible injury or death.

DANGER (red) indicates a hazardous situation, which if not avoided, will result in death or serious injury.

WARNING (orange) indicates a hazardous situation, which if not avoided, could result in death or serious injury.

CAUTION (yellow), used with the safety alert symbol, indicates a hazardous situation, which if not avoided, could result in minor or moderate injury.

CAUTION (yellow), without the safety alert symbol, is used to address practices not related to personal injury.

NOTICE is used to address practices not related to personal injury.

# Safety Decal Locations

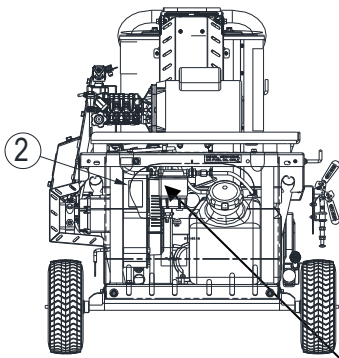

Fig. 1574210\_2

**⚠ WARNING**

**SCALE BUILD-UP/EXPLOSION HAZARD**

- Failure to properly maintain the coil can result in a steam explosion.
- Scale or lime build-up will act as an insulator and decrease coil efficiency.
- Weakening of the coil tube due to hot spots can result in a coil rupture.

**CHEMICAL EXPOSURE HAZARD**

- Always wear properly rated safety goggles when descaling the coil.
- Always wear rubber gloves when handling coil cleaning chemical.
- Understand all safety hazards and first aid measures for coil cleaning chemical being used.
- Follow coil cleaning chemical manufacturer's directions when handling, mixing and using coil cleaning chemical.

Read owner's manual. See maintenance section of manual for descaling procedure.  
Read the coil cleaning chemical safety information.  
Serious injury or death can result if safety instructions are not followed.

802203

**⚠ WARNING**

**ROTATING MACHINERY**

Clothing or hair can become rapidly entangled in unguarded rotating parts, resulting in serious injury or death.

**DO NOT operate without power transmission belt guard in place.**

**⚠ WARNING**

**High Pressure Spray Hazard**

- High pressure spray can cause injection injury, eye injury, and loss of balance. Serious injury could result from unintentional release of high-pressure spray from the gun upon engaging the trigger.
- ALWAYS turn Power Switch to OFF position and relieve system pressure when leaving pressure washer unattended.
- Total Start/Stop feature allows temporary motor shut-off (STOP) when the Trigger is disengaged and allows motor to restart (START) when the Trigger is reengaged. This Feature should NEVER be used to shut off the pressure washer when not in use.

**⚠ WARNING**

**BURN HAZARD**

Do not touch hot surface.

797513

**PRESSURE WASHER**

Manufactured by: **NORTH STAR**

ITEM#: 1574210A

Serial #: \_\_\_\_\_

Rated Pressure: 21.7 MPa / 1100 PSI Flow: 2.68 LPS / 1.16 GPM

Permissible Pressure: 13.8 MPa / 2000 PSI Water Nozzle: 2.00

Motor HP: 1.20 Motor: 120V/60C Amps: 25 Phase: 1 Max

Max Output Water Temp: 121°C / 250°F Fuel Nozzle: 75 A 60 deg

Max Power Output: 65.8 KW / 125.10 HP/12.75

Max Fuel Pressure: 1.6 MPa / 230 PSI Flow Rate: 4.31 LPS / 1.14 GPM

Chemical: 2.3 gal / 9.0 liter Compatible to Non-Combustible.

UNITS: \_\_\_\_\_

BARCODE: \_\_\_\_\_

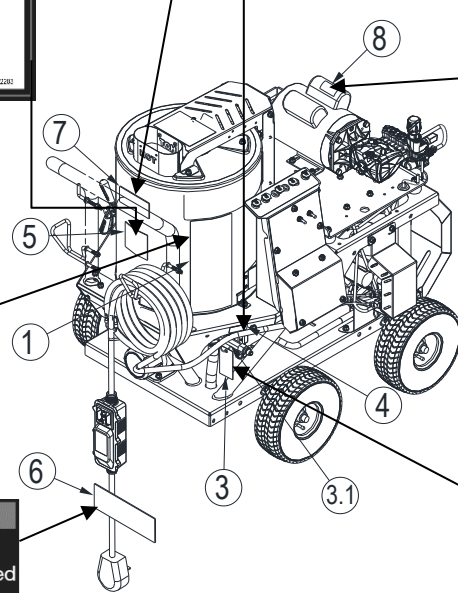

**⚠ DANGER**

**FOR OUTDOOR USE ONLY!** Using this pressure washer indoors CAN KILL. YOU IN MINUTES. Engine exhaust and burner exhaust contain carbon monoxide. This is a poison you cannot see or smell.

NEVER use inside any building, structure or garage, EVEN IF doors and windows are open.

Only use OUTSIDE and far away from windows, doors, and vents.

**⚠ WARNING**

**High Pressure Fluid Forces / Burn Hazard**

High pressure spray can cause injection injury, eye injury, and loss of balance. Hot discharge fluid and hot surfaces can burn.

- NEVER direct discharge stream at or near any person. Do not allow any part of the body to come in contact with the fluid stream.
- Gun locks back - hold with two hands. Keep good footing and balance at all times.
- Surfaces of engine, burner, and wand can become very hot. Use only designated gripping areas of wand. Avoid contact with hot engine and burner.

**Fire / Explosion Hazard**

Spraying flammables can cause explosion. Fuel is flammable and explosive. Exhaust can ignite combustible materials.

- NEVER spray flammable liquids. Operate only where open flame or spark is permitted.
- NEVER fuel a running or hot engine or oil burner.
- Ensure there are no fuel leaks before starting. Keep sources of ignition and flames away.
- Use approved container only for transferring fuel. Clean up fuel spills immediately.
- Keep engine and burner exhaust at least 7 feet from all combustible objects. Situate on heat-resistant flooring when using burner.

**Chemical Exposure Hazard**

- Understand all safety hazards and first aid measures for chemicals being used.
- Follow chemical manufacturer's directions when handling and cleaning with chemicals. Wear safety gear as directed.

**Electric Shock Hazard**

Keep spray away from electrical wiring, or electric shock / electrocution could occur.

CAUTION: To Reduce Risk of Injury, Read Operating Instructions Carefully Before Using.

**⚠ WARNING**

**RISK OF ELECTROCUTION**

1. Connect only to properly grounded outlet. Do not remove ground pin.
2. Inspect cord before using - Do not use if cord is damaged.
3. Keep all connections dry and off the ground.
4. Do not touch plug with wet hands.
5. This product is provided with a Ground Fault Circuit Interrupter built into the power cord plug. If replacement of the plug or cord is needed use only identical replacement parts.
6. Read owner's manual before using.

**DO NOT REMOVE THIS TAG**

©2005 NT+E Co. 800-270-0810 Part No. 778070

**⚠ WARNING**

**IF RUPTURE DISK ACTIVATES AND RELEASES WATER:**

- Turn heat switch OFF
- Turn power switch OFF
- Turn water supply OFF
- Pull spray gun trigger to release pressure
- Unplug pressure washer, or remove the spark plug wire

Do not use pressure washer until Product Support arranges for repair or replacement.

Failure to turn off immediately could result in serious injury.

Call 1-800-270-0810

Always make sure safety labels are in place and in good condition. If a safety label is missing or not legible, order new labels or unsafe operation could result. To order replacement safety labels, call NorthStar Product Support at 1-800-270-0810.

Ref#	Part#	Description	Qty
1	782325	Decal, Danger and Warning	1
2	786632	Decal, Rotating Equipment Warning	1
3	798057	Hangtag, Rupture Disk Warning	1
3.1	32821	Lanyard, Hangtag Warning	1
4	797513	Decal, Burn Hazard Decal	1
5	802203	Decal, Descaling Warning	1
6	778070	Decal, Cord Warning	1
7	802940	Decal High Pressure Spray Hazard	1
8	NA	Decal, Serial Number	1

# Assembly and Initial Set-Up

## Step 1. Inspect & Unpack

Inspect the pressure washer immediately after you receive delivery for missing parts or damage. Find and separate components identified in Fig.1574210\_3 and Figure 1574210\_4.

- For *missing or damaged* components, contact Product Support at 1-800-270-0810.

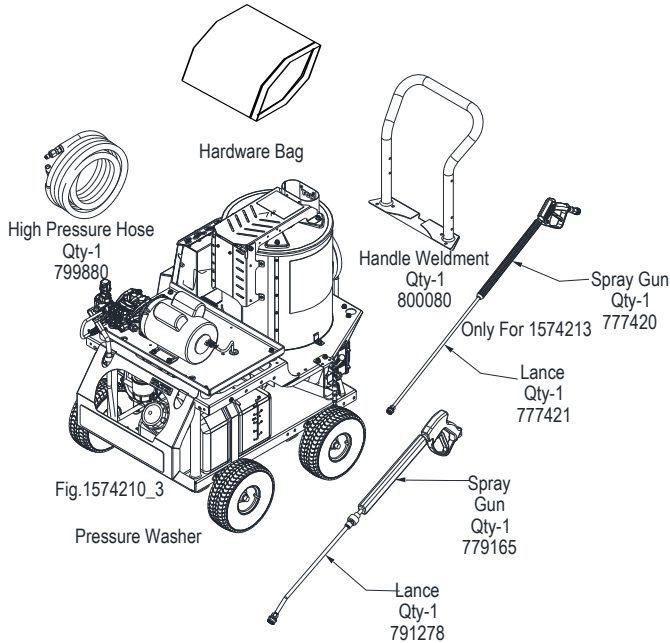

Fig.1574210\_3 – Pressure Washer Components

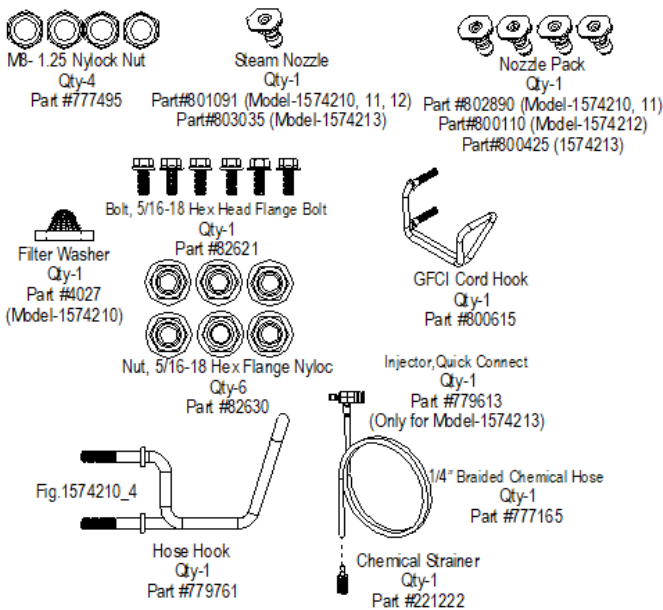

Fig.1574210\_4 – Parts to be installed

## Step 2. Assembly

You must assemble your pressure washer before it can be used. Refer to Fig.1574210\_5 and follow the steps listed below:

- Install handle with six (6) 5/16"-18 x 3/4" Flange bolts through base and handle and secure with six (6) 5/16"-18 Flange bolts.
- Install Hose Hook into right side of handle using two (2) M8 Nuts.
- Install GFCI Cord Hook into right side of handle using two (2) M8 Nuts.
- Install Nozzles into designated nozzle storage location.

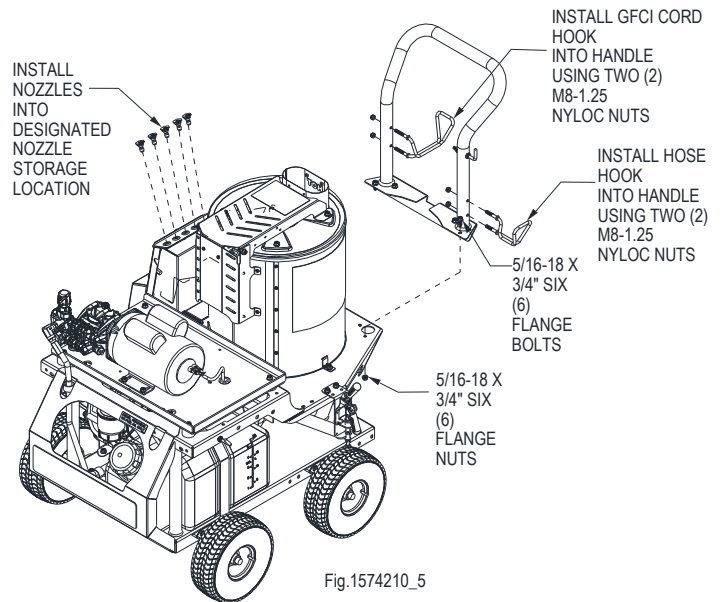

Fig.1574210\_5

## Step 3. Initial Pump & Motor Preparation

### Prepare Water Pump

Verify pump oil level. Refer to Fig.1574210\_6 and follow the steps listed below.

**NOTE:** The Pump is shipped with oil.

- Remove shipping tape and black vent plug (if present) from oil fill cap.
- Verify that oil level is halfway up the sight glass.
- If oil level is low, use the oil type from below table. See page no.13.

## Assembly and Initial Set-Up

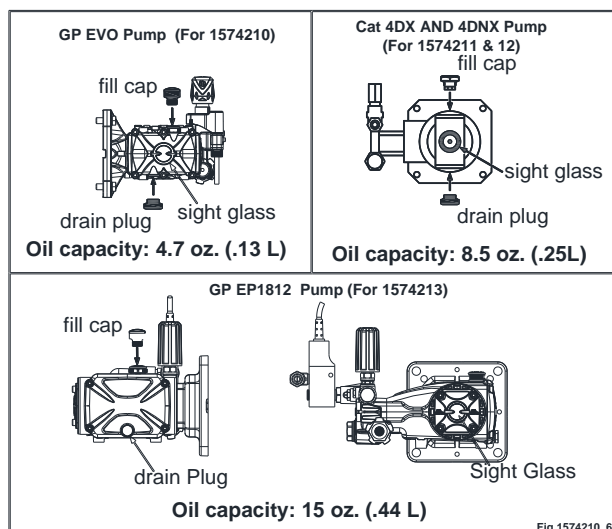

### Step 4. Verify Electrical Connection

#### Grounding

Product must be grounded. The supply cord is equipped with an equipment-grounding conductor and a grounding plug. This plug must be plugged into an outlet that is properly installed and grounded in accordance with all local codes and ordinances.

#### Ground Fault Circuit Interrupter Protection

Connecting the pressure washer through some type of ground fault circuit interrupter (GFCI) protector is required to comply with the National Electric Code (NFPA 70) and to provide additional protection from the risk of electric shock.

Note: Before use, your GFCI should be tested at either built-in or receptacle base.

1. This Product is provided with a ground fault circuit interrupter built into the power cord or plug. If replacement of the ground fault circuit interrupter or cord is needed, use only identical replacement parts

#### **⚠ DANGER: Electrocutation hazard**

Improper connection of the equipment or grounding conductor can result in a risk of electrocution. Check with qualified electrician or service personnel if you are in doubt as to whether an outlet is properly grounded. Do not modify the plug provided with the product. If it will not fit the outlet, have a proper outlet installed by a qualified electrician. Do not use any type adapter with this product.

#### Extension Cord

This appliance cord is equipped with a GFCI, do not use extension cords. If the appliance cord is not equipped with a GFCI, the appliance and any extension cord used should be connected only to a GFCI-protected power source.

1. Use only extension cords that have grounding-type plugs and female cord connectors that accept the plug from the product.
2. Use only extension cords that are intended for outdoor use. These extension cords are identified on the packaging or on the cord by a marking "Acceptable for use with outdoor appliances; store indoors while not in use."
3. Use only extension cords having an electrical rating not less than the rating of the product.
4. Do not use a damaged extension cord. Examine extension cord before using and replace if damaged.
5. Do not abuse extension cord and do not yank on a cord to disconnect.
6. Keep cord away from heat and sharp edges.
7. Always disconnect the extension cord from the receptacle before disconnecting the product from the extension cord.

#### **⚠ WARNING**

To reduce the risk of electrocution, use only a GFCI-protected extension cord or plug into GFCI outlet. Keep all connections dry and off the ground. Do not touch plug with wet hands.

# Assembly and Initial Set-up

## Step 5. Moving and Handling

**⚠ WARNING: Lifting hazard**

The pressure washer is heavy. It can crush and cause serious injury if it rolls out of control or tips over. Follow the instructions below for safely moving the pressure washer.

### Moving your pressure washer around

- Use handle to manually move pressure washer.
- To turn, push down slightly on handle and pivot pressure washer on its back wheels. Do not move or operate crosswise on a slope. High center of gravity can cause tipping.
- Lock wheels with brake to prevent inadvertent movement.
- Never pull by hose. Do not move this machine by pulling on the hose. Hose or connections could fail and result in catastrophic high-pressure release of fluid as well as hose whipping.

**To reduce risk of injury, do not attempt to manually lift the pressure washer. Use a shallow ramp to raise or lower pressure washer to a different elevation.**

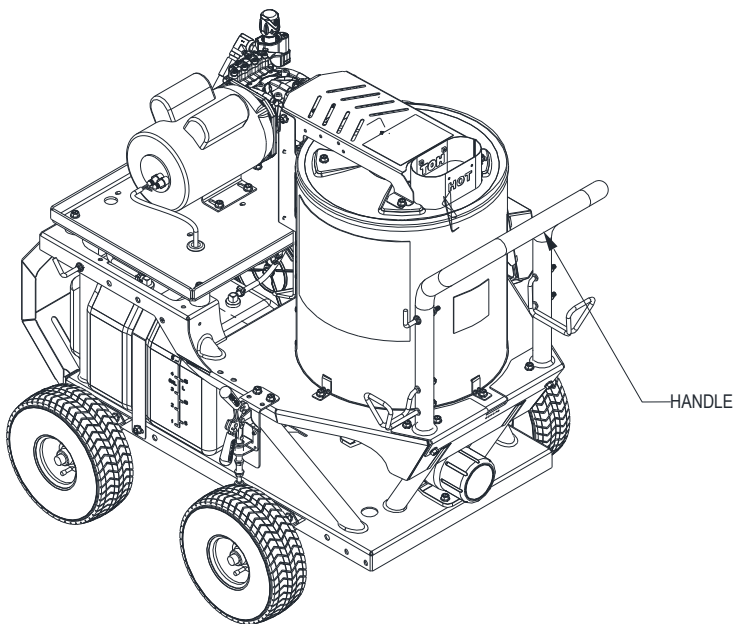

Fig.1574210\_7

## Before Each Use

Follow the steps below prior to each use.

### Step 1: Inspect Equipment

#### Electrical

- Inspect cord before using. Do not use if cord is damaged.
- Connect only to properly grounded outlet.
- Keep all connections dry and off the ground.
- Do not touch plug with wet hands.
- If product is provided with a GFCI built into the power cord plug, use only identical parts if replacement is necessary.

#### Pump Oil

- Check oil level with sight glass (or dip stick). If low, add type of oil indicated below.

CAUTION		
Pump	Model	Oil Type
GP EVO	1574210	SAE 30 Non-Detergent Oil or Pressure Washer Pump Oil (Part# 4043)
GP EP1812	1574213	
CAT 4DX	1574211	SAE 30 Non- Detergent Oil or Cat Pump Oil part # 22158
CAT 4DNX	1574212	

Never run the pump without sufficient lubrication!

- Replace oil fill cap after any additions.

#### Spray System

Because of the high-pressure fluid hazards, a special check must be made before each use to look for signs of wear, cracks, looseness or leaks in the hoses, fittings, wand, trigger gun and connections. See special instructions for checking and repairing high-pressure hoses within the "Maintenance & Repair" section.

- Check and clean nozzle orifice.
- Clean garden hose water inlet filter. (See Maintenance instructions.)

#### WARNING: High pressure fluid injection hazard

High-pressure fluid discharge from leaks (even pin-sized) or ruptured components can pierce skin and inject fluid into the body. Injection injury can result in blood poisoning and/or severe tissue damage leading to infection, gangrene, and possibly amputation.

#### WARNING: Respond to fluid injection immediately

If injured by high-pressure fluid, no matter how small the wound is, see a doctor at once. A typical injection injury may be a small puncture wound that does not look serious. However, severe infection or reaction can result if proper medical treatment is not administered immediately by a doctor who is familiar with injection injuries.

- Never use a finger or skin to check for leaks.
- Never operate machine with damaged or missing hoses/parts.
- Never attempt to repair a high-pressure hose or component – always replace it with part that is rated at or above the pressure rating of this machine.

#### Burner Fuel System (if heated water to be used)

Inspect Burner fuel system for leaks BEFORE starting pressure washer. Look for:

- Signs of leaks, wetted areas, or deterioration
- Chafed or spongy fuel hose
- Loose connections
- Loose or missing fuel hose clamps
- Damaged fuel tank

#### WARNING: Fuel leak hazard

Burner fuels are highly flammable and fuel leaks can result in fire or explosions. You can be burned and seriously injured if there is a fuel leak when you start the pressure washer.

#### Periodic Maintenance

Other periodic maintenance is listed within the "Maintenance & Repair" section.

**Note: Do not start pressure washer until all needed repairs have been completed.**

#### Step 2. Check and Fill Burner Fuel Tank

If you are planning to use heated water, check level of burner fuel tank. If fuel is needed, use #1 or #2 diesel, B5 or lower biodiesel, kerosene or fuel oil. Use these precautions each time you fill:

1. Regularly inspect fuel systems for leaks.
2. Fill fuel tank OUTDOORS- never indoors, and stay away from all sources of heat, sparks and flames.
3. Use an UL approved portable container to transfer fuel to machine.

## Before Each Use

### Filling Burner Fuel Tank (if heated water to be used)

**⚠ WARNING: Flammability hazard**

Burner fuels are highly flammable. Turn the machine off and allow it to cool for at least 2 minutes before removing fuel cap; as a running or still hot burner is hot enough to ignite fuel.

#### After Machine Has Cooled:

1. Remove burner fuel cap.
2. Add fuel through the fill opening. Do not overfill. Allow at least 1/2" of empty space below fill neck to allow for fuel expansion.
3. Replace fuel cap securely before starting burner.
4. Clean up fuel spills/splashes immediately.
  - If possible, move the machine away from spilled fuel on the ground.
  - Wipe up spilled fuel and wait 5 minutes for excess fuel to evaporate before starting burner.
  - Fuel soaked rags are flammable and should be disposed of properly.
  - If fuel is spilled on your skin or clothes, change clothes and wash skin immediately.
5. Store extra fuel in a cool, dry place in an UL-approved, tightly sealed container.

### Step 3. Select Suitable Worksite Guidelines

**⚠ WARNING: Location hazard**

You must choose a suitable site for operating your pressure washer to avoid equipment damage and/or injury and possible death from carbon monoxide poisoning, fire/explosion, uncontrolled equipment movement/tip over, or slips and falls. While designed primarily for outdoor usage, this electric powered pressure washer may be used inside large commercial buildings if special additional precautions are taken. See below.

### For All Indoor and Outdoor Uses

#### Placement of the Machine:

- Where it will NOT be exposed to rain, snow, or direct sunlight. Exposure to water can cause electric shock.
- Where no flammable vapors, dusts, and gases are present.
- At least 7 feet away from combustible materials (when burner used).

- Away from all building windows and air intakes (when burner used).
- Away from other heat-generating equipment.

#### Positioning:

- The pressure washer should be positioned on a firm, level (less than 3-degree slope), heat resistance surface with good drainage and a nearby water supply.
- Ensure that the pressure washer sits level and will not slide or shift during operation. If applicable, block the pressure washer's wheels to prevent movement. Surface should be heat resistant if you will be using the burner for heated spray.
- Block wheels to prevent movement.

#### Airflow:

- Provide for adequate, unobstructed airflow for cooling and combustion air.
- Do not allow debris to accumulate or block airflow.
- Do not operate with a tarp, blanket, or cover surrounding the machine.
- Do not place any objects against or on top of the unit.

#### Electrical Precautions:

- To reduce the risk of electrocution, keep all cord connections dry and off the ground.
- Do not touch plug with wet hands.

### For Indoor Hot Water/Burner Use

#### Exhaust:

- Hot fumes from burner must be exhausted through a hood or piped to the outside.
- Place the unit so that the exhaust fumes will not be directed towards people or building air intakes.

#### Precautions:

- Keep a fire extinguisher rated "ABC" nearby. Keep it properly charged and be familiar with its use.
- Ensure that working, battery-operated or battery back-up carbon monoxide alarms are used in any structure that is in close proximity to the running pressure washer.

## Before Each Use

- An abundant amount of air must be available for proper combustion and cooling. Do not install in small, enclosed areas without an ample circulation of supply air.
- For more details, refer to NFPA 31: *Standard for the Installation of Oil-Burning Equipment*. Chapter 5 provides guidelines on how to ensure adequate air is provided for safe combustion.

 **DANGER: Carbon monoxide poisoning hazard**

Exhaust fumes from the burner contain carbon monoxide (CO), a poisonous gas you cannot see, smell, or taste. The CO generated by the pressure washer can rapidly accumulate, even in areas that appear to be well ventilated, resulting in dangerous and fatal concentrations within minutes. **ONLY** run pressure washer outdoors and away from air intakes. **NEVER** run pressure washer inside any enclosed or semi-enclosed spaces, including homes, garages, basements, sheds, boxes, pick-up truck beds, RVs, or boats. These spaces can trap poisonous gases, **EVEN** if you run a fan or open windows. If you start to feel sick, dizzy, or weak while using the pressure washer, shut off the motor and get to fresh air **RIGHT AWAY**. See a doctor. You may have carbon monoxide poisoning.

# Operation

## Step 1. Connect Hoses, Water Supply, and Spray Nozzle

Note: The electrical power and pump are both off during Step 1 procedures.

### Attach Garden Hose to Water Supply

- Acquire a suitable garden hose:
  - The water supply garden hose must have an inside diameter of at least 5/8". If the hose is more than 100 ft. long, the diameter must be at least 3/4".
  - Always use a flexible rubber hose for your water supply. Do not use rigid piping.
  - The use of a backflow preventer on the supply hose is recommended and may be required by local code.
- Attach garden hose to water supply.

### Check Water Supply

- Make sure the water supply is clean. Debris can cause excess pump wear and reduce performance.
- Make sure the water supply is steady and capable of flowing at a rate 20% over the rated flow of your pump. An insufficient water supply will damage your pump. Use a stopwatch to time how long it takes to fill a 5-gallon bucket with your garden hose. It should take less than 100 seconds.

### Connect Water Supply to Pump

- Confirm rubber washer and inlet filter screen are in water pump inlet. (See "Component Identification" section for location of water inlet)
- Run water through garden hose for 30 seconds to clean out debris. Turn off water.
- Connect garden hose to water pump inlet on pressure washer and turn on water valve.

### Connect Pressure Hose to Pump

Uncoil high-pressure hose. Attach quick connect end of hose to pressure washer's water outlet and other end of high-pressure hose to spray gun by following the "Quick Connect Procedure" below.

## **⚠️ WARNING: Incompatible component hazard**

NEVER operate this pump with components (such as hose, connections, and spray gun) rated for lower pressure and/or temperature limits than the machine's maximum rated pressure and temperature, or component will likely rupture and cause serious personal injury from escaping high pressure fluids.

### Quick Connect Procedure

- Pull quick connect collar back (Figure 9a).
- Push hose or nozzle firmly against stop.
- Let go of collar (Figure 9a).
- Pull (hose or nozzle) to assure a tight connection.

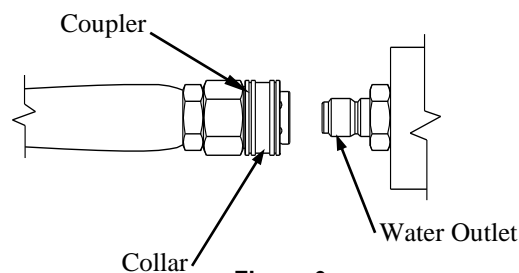

Figure 9a

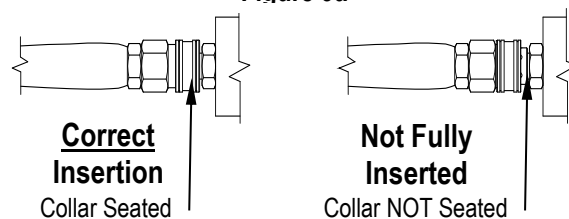

Figure 9b

Figure 9c

### Select Spray Nozzle

Five high-pressure nozzles and one low-pressure nozzle are supplied.

Note: A wider angle produces a lower impact pressure on surface. Nozzles from other sources may not fit the coupler and become a hazard.

Color of Nozzle:	Spray Angle	Used For:
Yellow	15°	Tough Stains/Stripping
Green	25°	General
White	40°	Light Cleaning
Black (Low Pressure)	65°	Chemicals
Orange	15°	Steam

# Operation

Note: Use only the black low-pressure nozzle for spraying chemicals, which provides the proper mixing ratio.

## Attach Nozzle to Spray Gun

### **⚠️ WARNING: Depressurize first**

Any time you remove/install/change a nozzle, you must depressurize hose line by squeezing the spray gun trigger while the Motor is off. Even if the Motor has been off for a long period of time, the hose may remain dangerously pressurized.

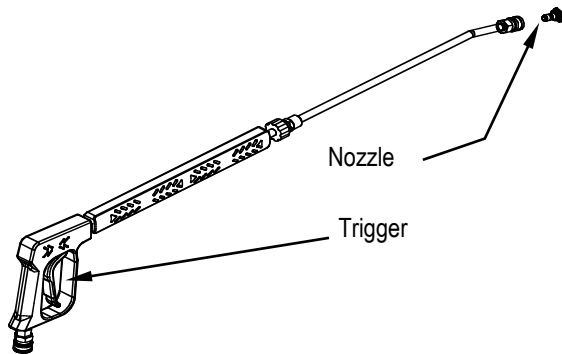

1. Make sure the Motor is off and the hose line depressurized.
2. To install the nozzle, pull the collar back and twist the nozzle firmly into the coupler on the end of the wand. (Fig. 10a)

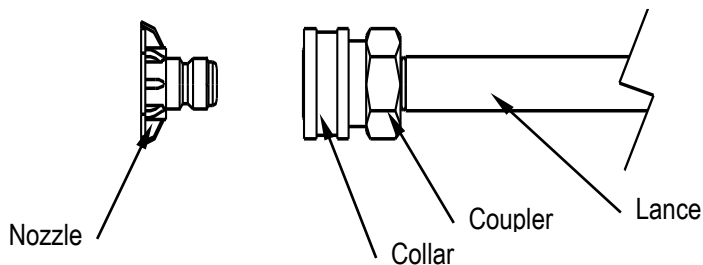

Figure 10a

3. Release the collar, making sure it springs back and re-seats to its original (non-retracted) position. (Fig. 10b). *Check the connection by pulling on the nozzle to ensure a tight connection -- if correctly inserted, nozzle will rotate but not pull out.*

### **⚠️ WARNING: Projectile hazard**

Sprayer nozzle can become a projectile and cause serious personal injury or damage if not properly connected to the spray gun.

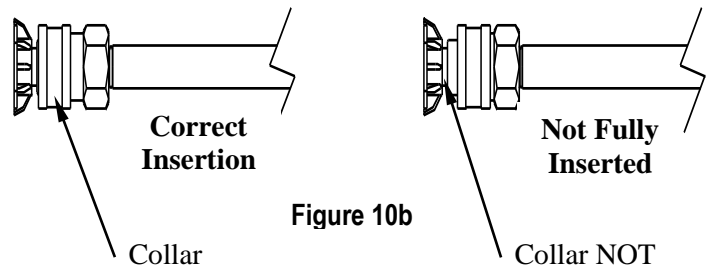

Figure 10b

## Step 2. Pre-Spraying Procedure

### Safety Rules

**Prevent slips/loss of balance.** High-pressure spray could cause you to lose balance from kickback forces, and wet surfaces can be slippery.

- Keep good footing and balance at all times.
- Do not overreach.
- Do not stand on unstable support when spraying.
- Use extreme caution when spraying from a ladder or scaffolding, ensure it is firmly anchored from sway or tip-over. Use extreme caution to avoid falling as spray gun kick can propel you off the ladder or scaffolding.
- Be aware of puddles and slippery surfaces. Ensure there is adequate drainage to prevent pooling of water.

**Keep spray away from electrical wiring.** Spray contact with electrical wiring will likely result in severe electrical shock or electrocution.

**Keep spray away from people.** Never direct discharge stream at or near any person. Do not allow any part of the body to come in contact with the fluid stream.

**Prevent surface damage & flying debris.** Surfaces being sprayed must be strong enough to withstand high-pressure spray, or damage may result. In addition, high-pressure spray will dislodge unsecured objects, surface chips, and debris, resulting in hazardous flying objects that can cause personal injury or property damage. Do not spray brittle surfaces or breakable, fragile, unsecured objects, such as:

- Stucco or laminar flagstone
- Some painted surfaces
- Windows or glass doors (because they may break)
- Light fixtures, flowerbeds, mailboxes
- Unsecured, lightweight objects

# Operation

Prepare to wash small parts in a basket so the pressure does not push them away. Clamp down larger, lightweight parts.

## Personal Protective Gear

### **WARNING: High pressure spray hazard**

- High pressure spray can cause injection injury, eye injury, and loss of balance. Serious injury could result from unintentional release of high-pressure spray from the gun upon engaging the trigger.
- ALWAYS turn power switch to OFF position and relieve system pressure when leaving pressure washer unattended.
- Total Start/Stop feature allows temporary motor shut-off (STOP) when the trigger is disengaged and allows motor turn-on (START) when the trigger is reengaged. This feature should NEVER be used to shut-off pressure washer when not in use.

When operating the machine, wear:

- Waterproof, thermally insulated gloves
- Safety glasses with side and top protection
- Protective clothing
- Non-slip, protective footwear
- Respirator or mask to avoid inhalation of vapors if directed on the chemical label (if spraying chemicals).

## Purging

Note: Pressure washer will first be purged using water supply pressure only, not pressure washer pump. **Do not plug electric pump in yet.**

- Turn on water supply.
- Disengage safety latch and squeeze trigger to attain a steady stream of water. This purges the pump of air and impurities.
- To prevent accidental spraying, engage the safety latch on spray gun trigger by rotating it to the locked position.

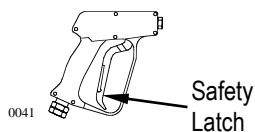

Figure 11

## Step 3. Spraying

- Make sure you have attached the appropriate spray nozzle.
- Clear the cleaning area of all persons. Keep children and pets away.

## Starting

- Plug unit into a grounded outlet. Press RESET on the GFCI (if applicable).
- Start motor to power the pump by turning Power Switch ON.

## Spraying Procedure

- Never run the machine without sufficient pump oil or sufficient water to cool the pump.
- Hold the spray gun firmly with two hands and a sturdy stance (gun kicks back when triggered).
- Nozzle should be 12" to 24" from the work, closer for tough areas.
- Disengage safety latch and start spraying at the top using long, even, side-to-side, overlapping passes.
- The pressure washer is set and locked to the maximum rated pressure when it leaves the factory. To reduce the pressure, turn the Unloader knob counterclockwise (Fig.1574210\_9).
- If temporarily stopping, interrupting spray, rotate trigger safety latch downward to the locked position to guard against accidental trigger release.

Note: Do not attempt to secure the spray gun open by blocking or tying the spray gun in the on position. Uncontrollable hose whipping can occur if grip is lost.

- Always turn off the motor by turning Power switch off and then activate spray gun trigger to relieve system pressure when:
  - The sprayer is unattended, or when
  - Disconnecting hoses, installing/cleaning nozzles, or servicing the pump.

## Using Chemicals for Cleaning (if desired)

Use only NorthStar pressure washer chemicals or chemicals specifically formulated for use with pressure washers. Don't use acids, corrosives, or abrasive or flammable liquids. Breathing hazards, surface burns/corrosion, or fire/explosion could result.

Follow the Chemical Manufacturer's Label Instructions When Handling or Spraying Chemicals:

- Understand all safety hazards and first aid for all chemicals being used.

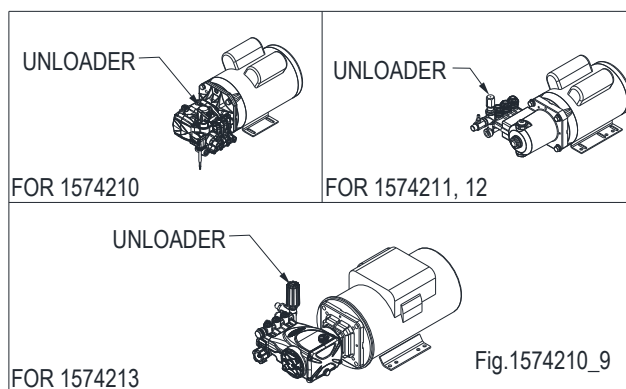

## Operation

- Wear protective gear as directed. Always wear protective gloves when handling and cleaning.
- When cleaning filters, check whether dangerous chemicals have been used with the filter and take any precautions that may have been recommended by the supplier of these chemicals.
- Always dispose of hazardous fluids per local, state, and national guidelines.
- Rinse with high-pressure spray, either hot or cold.
  - Turn heat switch ON and adjust thermostat to desired temperature. (For steam spraying, set temperature at 212°F or higher and use YELLOW nozzle.)
  - Burner will only fire as trigger is squeezed – follow instructions for spraying.

### CAUTION: Chemical mixture

The special NorthStar braided chemical hose when placed within a liquid and attached at the pump's chemical injection port will inject 1 part chemical to 15 parts water. Chemicals must be pre-diluted in accordance to instructions to accommodate the additional 15:1 dilution ratio which will occur in the pump.

### Chemical Spraying Preparation:

- Prepare (dilute) cleaning solution as required for the job. (Recall that this chemical solution will be automatically mixed in the pump with water at a ratio of 15 parts water to 1 part diluted chemical solution.)
- Press braided chemical hose over the pump's chemical injector.
- Submerge suction strainer connected to braided chemical hose into chemical solution bucket.
- Make sure the BLACK nozzle is attached to spray wand before beginning to spray chemicals – High-pressure nozzles cannot apply chemicals.
- Warm or cold water can be used. If warm water is specified on chemical label, start burner according to the instructions in the following section, "*Hot Spray Procedure.*"

### Chemical Spraying Procedure:

- Disengage safety latch and apply chemicals evenly to the cleaning surface working from bottom upward, using long, even, and overlapping passes.
- Allow chemicals time to react with dirt before rinsing. Do not allow the chemical to dry on, reapply as needed to prevent surface from drying.

### Rinsing:

- Change to a high-pressure nozzle for rinsing. Changing to a high-pressure nozzle will automatically stop the flow of chemicals into the water stream.

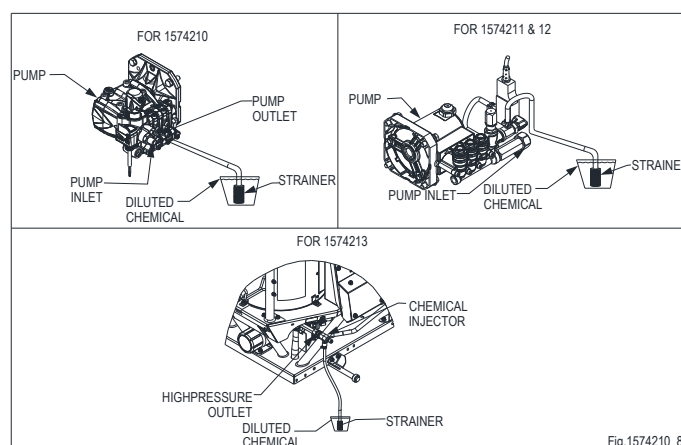

# Operation

## Hot Spray Procedure

**⚠ CAUTION: Metal burn hazard**

Use of burner will make spray gun hot. Avoid touching wand. Serious burns from hot metal could occur if touched.

- Before starting burner, make sure vicinity is free of flammable vapors, dust, gases, or other potentially combustible materials. Operate only where open flame or torch is permitted and neither flammable vapors nor combustible objects are present.
- Ensure there is fuel in burner fuel tank.
- Wait before re-lighting burner. NEVER attempt to immediately re-light the burner if it doesn't ignite the first time. Unburned oil or gas may have accumulated, causing potential explosion or fire hazard.
- Burner automatically turns off when trigger is released or when temperature setting is reached.

Note: If burner exhaust is white, adjust burner for peak performance. See "Oil Burner Adjustment" section towards the back of this manual.

**⚠ DANGER: Carbon monoxide poisoning hazard**

Exhaust fumes from the burner contain carbon monoxide (CO), a poisonous gas you cannot see, smell, or taste. The CO generated by the pressure washer can rapidly accumulate, even in areas that appear to be well ventilated, resulting in dangerous and fatal concentrations within minutes. ONLY run pressure washer outdoors and away from air intakes. NEVER run pressure washer inside any enclosed or semi-enclosed spaces, including homes, garages, basements, sheds, boxes, pick-up truck beds, RVs, or boats. These spaces can trap poisonous gases, EVEN if you run a fan or open windows.

## Step 4. Stopping

Stop the Motor using the following steps:

**⚠ WARNING**

Never disconnect the high-pressure hose from the high-pressure outlet or spray gun while the system is pressurized, relieve pressure by squeezing the spray gun trigger after the motor is turned OFF.

For Model 1574210	For Model 1574211, 12 and 13
<ol style="list-style-type: none"><li>1. Turn heat switch to OFF position.</li><li>2. Spray cold water for two minutes.</li><li>3. Turn power on/off switch to OFF position.</li><li>4. Turn water supply OFF.</li><li>5. Squeeze trigger to relieve system pressure.</li></ol>	<ol style="list-style-type: none"><li>1. Turn thermostat knob to OFF position.</li><li>2. Spray cold water for two minutes.</li><li>3. Turn heat switch to OFF position.</li><li>4. Turn power on/off switch to OFF position.</li><li>5. Turn water supply OFF.</li><li>6. Squeeze trigger to relieve system pressure.</li></ol>

# Storage

## Between-Use Storage

Before storing, let machine cool for at least 5 minutes, as a hot engine can be a fire hazard. Place in a secure location where it will not be started by untrained persons.

An appropriate storage location is:

- Clean and dry.
- Away from sources of heat, open flames, sparks or pilot lights, even if the and burner fuel tank is empty. (Residual fuel vapors from tank can ignite.)
- Away from extreme high or low temperatures. (Do not store the unit in freezing conditions unless it is prepared as directed in “*Winter Storage Preparation.*”)

## Long-Term Storage Preparation (between infrequent uses and at end of season)

Prepare for long-term storage if you will not be using machine again for more than 30 days. Fuel can become stale when stored over 30 days. Stale fuel causes acid and gum deposits to form in the fuel system which can cause the machine to malfunction. *To avoid problems, the fuel system should be emptied or treated with a fuel preserver before storing the machine longer than 30 days.*

## Winter Storage Preparation

Machines containing water for cooling or those that use water during operation need special preparation for storage during the winter (or freezing) months to prevent water from freezing in the system.

Note: Long-term storage is treated differently than between-use storage.

Do not allow water to freeze in the pressure washer, high-pressure hose, or spray gun. Freezing water will cause damage to the equipment and can cause the spray gun to fail in the open position. A spray gun that has failed in the open position can whip around and cause personal injury when the pressure washer is started. Winterize as follows:

### Material List:

1. Two 5-gallon buckets
2. 4-5 foot long garden hose or equivalent (recommend 5/8" to 3/4" diameter with male 3/4" Garden hose threads on one end)

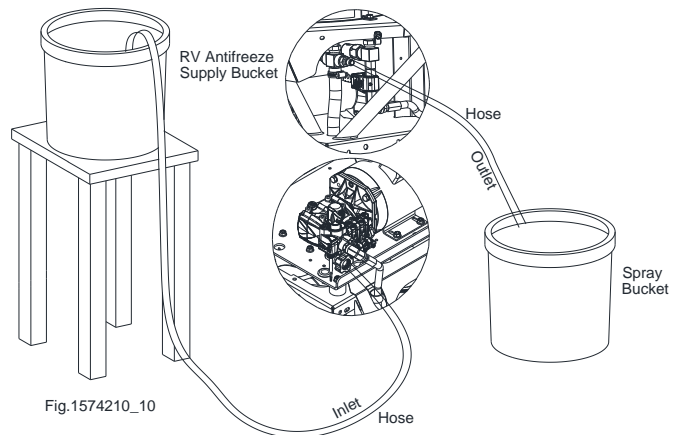

### Procedure:

1. In a 5 gallon pour at least 2 gallons of environmentally safe antifreeze. **Note:** whether using undiluted or pre-diluted antifreeze, follow manufactures mixing guidelines to ensure proper freeze protection.
2. Elevate bucket so it is higher than the unloader.
3. Connect a 4-5-foot-long garden hose or equivalent to inlet connection.
4. To ensure good priming fill hose with water or antifreeze mix before placing end into 5-gallon bucket of antifreeze.
5. With the nozzle removed, trigger gun off, and with burner off point trigger gun into a second empty 5-gallon bucket and start the unit.
6. With unit running, spray into the empty bucket for several seconds then release trigger for 2 seconds. Continue cycling the trigger gun multiple times until all the antifreeze has been drawn from the supply bucket. **Note:** if system was completely flushed you should see antifreeze in the spray bucket.
7. With unit shut off, remove hoses and drain excess antifreeze into spray bucket.
8. Properly dispose of antifreeze according state EPA laws.

## Storage

Alternately the system can be blown out with compressed air: **Note:** although this method can be effective for winterizing, the above antifreeze method is preferred because it ensures the entire plumbing system is flushed and lubricated.

### Materials:

1. Properly rated fittings (80 psi or higher) to connect air supply to inlet connection ( $\frac{3}{4}$ " garden hose) on pressure washer.
2. Air compressor with regulator able to set pressure between 60-80 psi.

### Procedure:

1. Connect hose and gun to outlet connection.
2. Connect air supply to inlet connection, ensuring regulator is set no higher than 80 psi.
3. Pull trigger on gun (with nozzle removed) and allow air to push water out of plumbing. Continue hold trigger gun open until water stops coming out of.
4. Turn off air compressor and pull trigger on gun to relieve any trapped pressure in the system.
5. Disconnect air compressor, hose, and trigger gun.
6. Remove thermal relief valve located at the bottom of the unloader (see Component identification page) and allow water from the bypass loop to drain out. Once drained reinstall thermal relief fitting.

### Prepare the pressure washer for storage

1. Make sure the Motor start switch is OFF.
2. Disconnect the high-pressure hose, garden hose, and spray gun.

**Let Pressure washer cool for 5 minutes** before moving the pressure washer to its storage location.

## Maintenance & Repair

### **WARNING: Maintenance hazards**

ALWAYS shut off water supply, bleed water pressure, turn off motor and unplug electrical cord before cleaning, adjusting, or servicing the pressure washer. After servicing, make sure all guards and cover shields are replaced before using. Follow all safety rules and recommended maintenance instructions. If a part needs replacement, only use factory approved repair parts. Replacement parts that do not meet specifications may result in a safety hazard or poor operation of the pressure washer and will void the warranty.

## Maintenance Schedule

Item	Frequency
Dust/debris removal	As needed, when visibly present
Inspect fuel system	Each use
Inspect spray system	Each use
Clean inlet filter for garden hose	Each use
Check tire pressure	Each use
Change pump oil	Each use After first 40 hours of use Every 3 months or 500 hours of use after that
Drain burner's fuel filter / water separator	Drain water as needed Change filter after 500 hours of use or annually
Descale heating coil	Annually, or more frequently as use and performance require (see instructions)
Inspect and clean flow switch	As needed
Inspect heating coil and desoot if needed	Annually
Inspect/clean/adjust electrodes	Annually
Perform engine maintenance	See Engine Owner's Manual

## Detailed Instructions – Maintenance & Repair

### Dust/Debris Removal

Do not allow air intakes to become blocked. If dust or debris accumulates on the pressure washer, clean with a damp cloth or soft bristle brush.

Do not spray pressure washer with a garden hose or pressure washer to clean. Water may enter parts of the pressure washer which will cause damage. Cleaning should be done with a damp sponge with the motor OFF.

### Inspect Fuel System(s)

Look for:

- Signs of leaks, wetted areas or deterioration
- Chafed or spongy fuel hose
- Loose connections
- Loose or missing fuel hose clamps

- Damaged fuel tank
- ### Inspect Spray System

### **WARNING: High pressure fluid injection hazard**

High-pressure fluid discharge from leaks (even pin-sized) or ruptured components can pierce skin and inject fluid into the body. Injection injury can result in blood poisoning and/or severe tissue damage leading to infection, gangrene, and possibly amputation.

- Never use a finger or skin to check for leaks.
- Never operate machine with damaged or missing hoses/parts.
- Never attempt to repair a high-pressure hose or component – Always replace it with a part that is rated at or above the pressure rating of this machine.

## Maintenance & Repair

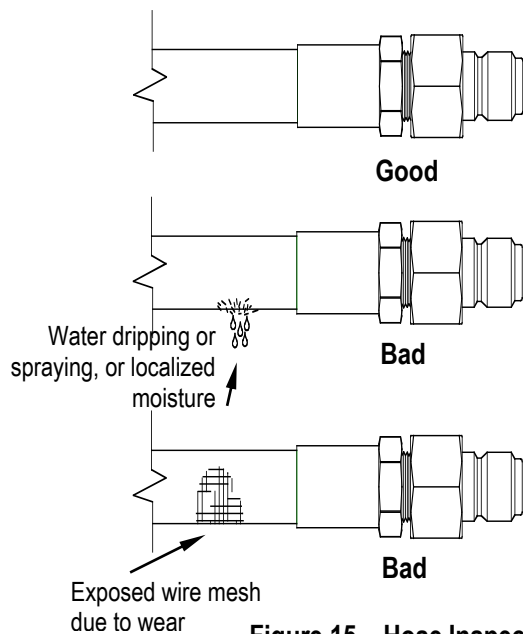

Figure 15 – Hose Inspection

- Carefully check hoses, fittings, wand, trigger gun and connections for signs of wear, cracks, looseness, or leaks.
- Replace before use if damaged or not functioning properly.
- Check and clean the orifice of nozzle to be used.

### Clean Inlet Filter for Garden Hose

- Unscrew garden hose from water inlet (if connected).
- Remove filter screen from water inlet.
- Run water through filter screen to clean.
- Reassemble.

### Check Tire Pressure

- Remove air cap on tires.
- Check tire pressure.
- If needed, fill tire to 30 psi. Do not over inflate.
- Replace air caps.

### Change Pump Oil

After the first 40 hours of use, and then every 3 months or 500 hours of use after that.

- Remove drain plug from pump. (See Fig.1574210\_6 earlier in the manual.)
- Drain pump oil into suitable container and dispose of according to local regulations.
- Reinstall oil drain plug.
- Make sure unit is sitting level. Fill pump with type of pump oil specified below. (See “Specifications”

section of this manual to determine the type of pump that came equipped with this pressure washer)

- For GP pumps: Use SAE30 non-detergent oil or Pressure Pump Oil Item #4043
  - For Cat pumps: Use SAE30 non-detergent oil or Cat Pump Oil Item #22158.
- Replace oil fill cap.

### Drain Burner’s Fuel Filter/Water Separator

Drain water from burner’s filter bowl as needed. Replace filter after every 500 hours of use or annually.

- **Important:** Always empty the burner’s fuel tank before removing the filter bowl.
- Check the filter bowl after each use of burner.

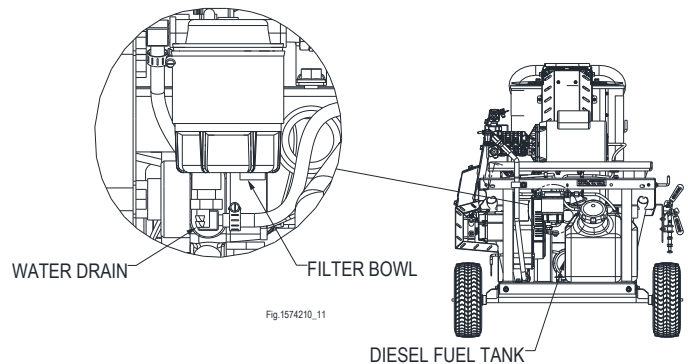

Drain accumulated water via water drain at the bottom of the bowl.

- After every 500 hours of operation or annually, empty the burner’s fuel tank to remove the filter bowl and inspect the fuel filter/water separator.

### Descale Heating Coil

If pressure washer is used where the water source contains a high mineral content, or is considered “Hard Water”, scale can build up inside the heating coil tubing. Scale deposits will decrease the performance of pressure washer by reducing both water flow and water pressure. The use of a water softener and an additional strainer may be needed in areas that have high mineral content in the water supply. More frequent descaling may be required if higher temperatures or steam mode is used regularly. Descale the coil tubing more frequently if you detect a decrease in pressure or temperature.

**CAUTION: De-scaling burn hazard**

Do not run the burner while de-scaling.

## Maintenance & Repair

Choose a well-ventilated area and use the recommended PPE (personal protective equipment) of the coil cleaning chemical manufacture when descaling the coil and/or using coil cleaning chemicals. This may include, but is not limited to:

- Rubber Gloves
- Goggles
- Apron

Required supplies:

1. Coil cleaner
2. 5-gallon bucket
3. Circulating pump
4. Supply hose A
5. Supply hose B
6. Return hose
7. Hose barb fittings, if applicable
8. Hose clamps, if applicable

**⚠ WARNING**

**SCALE BUILD-UP/EXPLOSION HAZARD**

- Failure to properly maintain the coil can result in a steam explosion.
- Scale or lime build-up will act as an insulator and decrease coil efficiency.
- Weakening of the coil tube due to hot spots can result in a coil rupture.

**CHEMICAL EXPOSURE HAZARD**

- Always wear properly rated safety goggles when descaling the coil.
- Always wear rubber gloves when handling coil cleaning chemical.
- Understand all safety hazards and first aid measures for coil cleaning chemical being used.
- Follow coil cleaning chemical manufactures' directions when handling, mixing and using coil cleaning chemical.

Read owner's manual. See maintenance section of manual for descaling procedure.  
Read the coil cleaning chemical safety information.  
Serious injury or death can result if safety instructions are not followed.

To descale the coil:

1. Connect hose(s) as shown below to the coil inlet, coil outlet and the circulating pump. Do not hook up the pressure washer hose or gun.

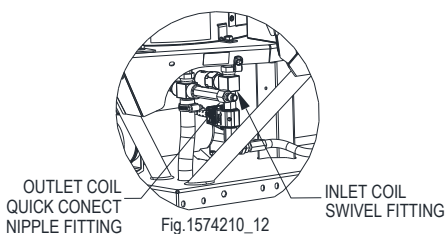

2. Add commercial coil cleaner to water and mix. Use an acid resistant 5-gallon bucket.
3. Place the remaining end of the Return Hose into the 5-gallon bucket.
4. Place the remaining end of the Supply Hose B into the 5-gallon bucket. We recommend using an inlet filter screen on Supply Hose B.
5. Connect the power supply to the circulating pump.
6. Turn on the circulating pump to begin circulating the coil cleaning solution.
7. Run the circulating pump for 1 to 3 hours (follow coil cleaner manufacturing instructions), recirculating the coil cleaning solution. **CAUTION:** Do not run the pressure washer or the burner.
8. Dispose of the cleaning solution where it is not harmful to animals or the environment. Follow the coil cleaner manufacturers disposal instructions.
9. Fill the 5-gallon bucket with fresh water.
10. Place the end of Return Hose back into the 5-gallon bucket with fresh water.
11. Place the end of Supply Hose B back into the 5-gallon bucket with fresh water.
12. Turn on the circulating pump to begin circulating the fresh water.
13. Run the circulating pump for 5 minutes, recirculating the fresh water.
14. Repeat steps 11-15 at least 3 times to ensure all remaining coil cleaning residue has been flushed out with fresh water.
15. Reinstall the outlet coil quick connect nipple fitting to the coil outlet.
16. Reinstall the inlet coil swivel fitting to the coil inlet.
17. Attach the high-pressure hose(s) to the high-pressure outlet on the machine.
18. Flush with fresh water and clean the garden hose water inlet screen when finished.

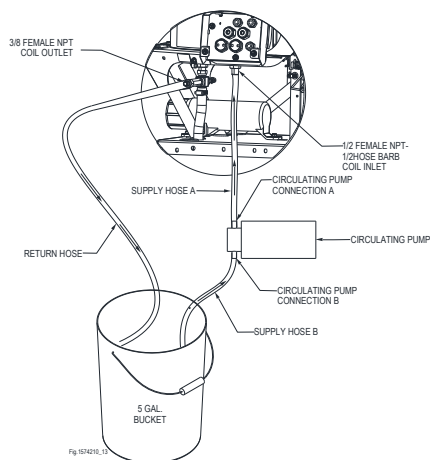

# Maintenance & Repair

## Inspect and clean the flow switch as needed

Mineral build-up and/or debris within the flow switch can occur and may affect burner operation if not periodically cleaned. Mineral build-up and/or debris can stop the movement of the shuttle inside the flow switch body. Shuttle movement is important because the burner will not fire if the shuttle does not move. The shuttle movement actuates a switch inside the flow switch housing which allows the burner to fire during spray mode.

- 1) Disconnect the swivel fitting from elbow to the inlet of the coil

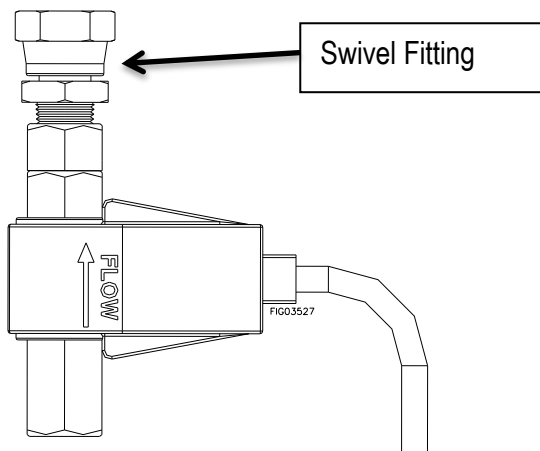

- 2) Remove the "Cap" fitting from the flow switch.

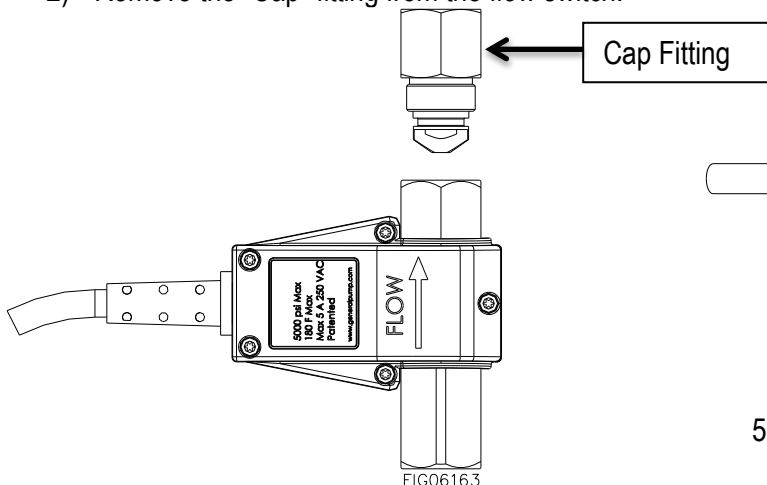

- 3) Slide out the "Shuttle Assembly". If the magnet in the shuttle assembly is damaged or missing, replace the entire flow switch assembly. To order a replacement flow switch assembly, call NorthStar Product Support at 1-800-270-0810.

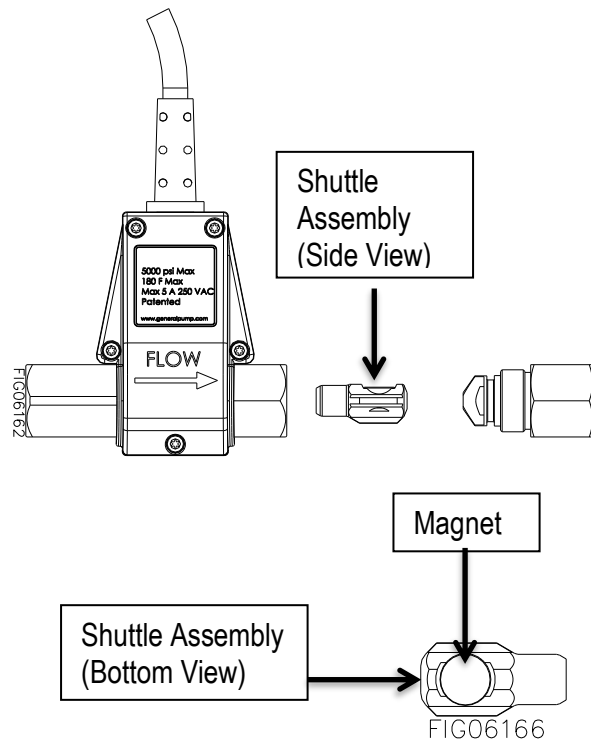

- 4) Observe the "Shuttle Assembly" and internal portion of "Body" for obstructions, hard water deposits and any other foreign debris. Remove the foreign debris with light scraping or compressed air. If no additional cleaning is required continue to Step 7. If additional cleaning is required continue to step 5.

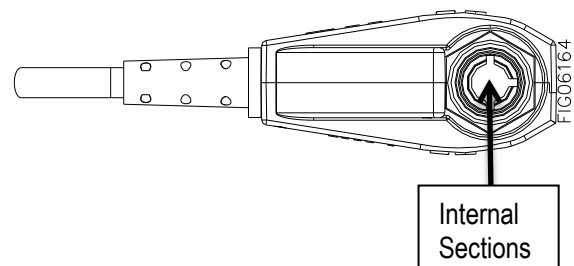

- 5) Remove the "Body" from the plastic "Enclosure" and soak the "Body" in CLR or similar solution to dislodge excess buildup. The screws (QTY 5) in the "Enclosure" are TORX T10.

## Maintenance & Repair

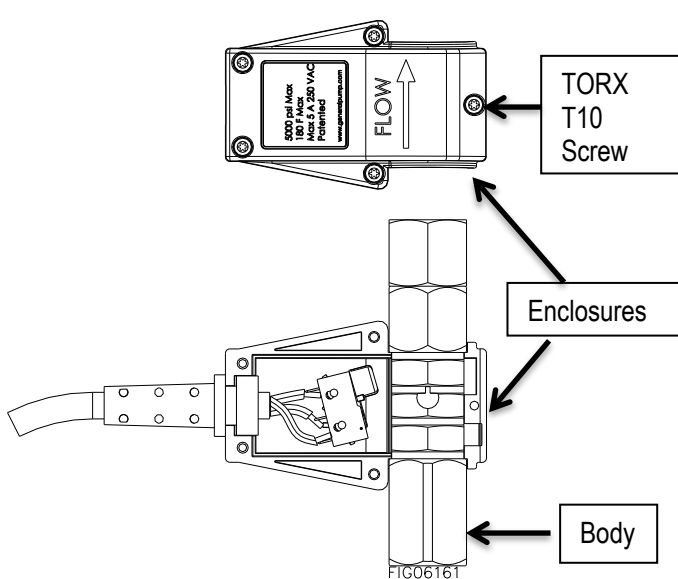

- 6) Rinse "Body"
- 7) When cleaning is complete reinstall the "Body" into the "Enclosures", taking care not to cause damage. Tighten the "Screws" into the body until they are snug. Do not over-tighten the screws.
- 8) Insert the "Shuttle Assembly" with the rounded end first. into the body. Align with arooves.

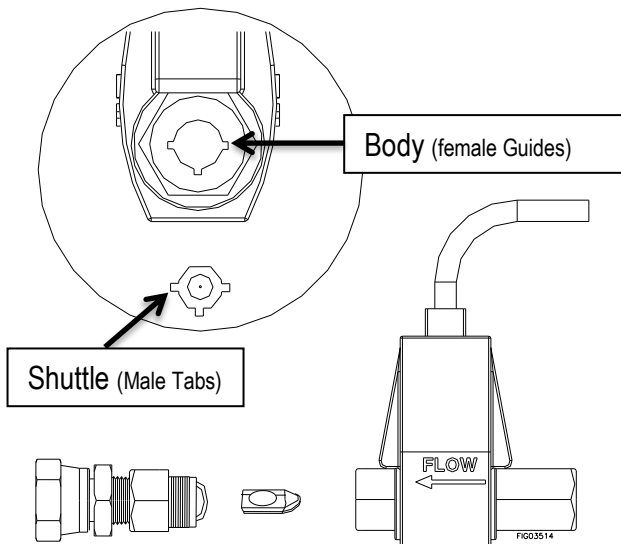

- 9) Inspect the O-ring on the "Cap", if it is damaged, replace the entire flow switch assembly. To order a replacement flow switch assembly, call Northstar Product Support at **1-800-270-0810**. If the O-ring is not damaged, re-install the "Cap" onto the "Body". Torque the cap to 100lb-in.

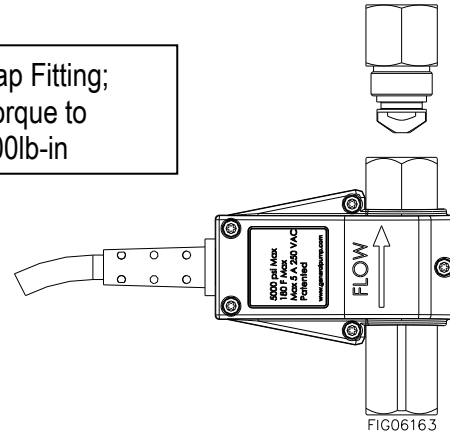

- 10) On the elbow on the inlet of the coil, remove any remaining thread tape/sealant. Re-apply new thread tape/sealant on the elbow. Re-connect the swivel to the elbow. Hand-tighten the swivel onto the elbow, and once snug, using a wrench continue to tighten the swivel two additional revolutions.

### Inspect Heating Coil and Desoot as Needed

Most coils never require desooting. However, poor grades of fuel oil or inadequate combustion air will cause heavy soot build-up on the outside surface of the heating coil tubing. These deposits will insulate the coil, which then restricts air flow through the heat exchanger and further aggravates the soot build-up. Be sure to wipe the sight glass. See Fig06172 on next page.

If soot has built up on the exterior of the coil tubing, clean as follows:

- 1) Wear Protective clothing, goggles, and gloves.
- 2) Disconnect Fuel line from outer cover. Disconnect Flame sensor and High Tension Leads from black box bolted to the guard on side of Outer Wrap.
- 3) Remove (4) 5/16" Bolts from Outer Cover.
- 4) Remove Outer Cover set aside.
- 5) Remove (4) 5/16" bolts and nuts off the hold down brackets on the Outer Wrap.
- 6) Remove all inlet and outlet fittings.
- 7) Remove the (2) 1-1/4" Jam nuts and the 3/8" bolt underneath the base.
- 8) Lift off Outer Wrap, Inner Wrap and Inner Cover. Set aside.

# Maintenance & Repair

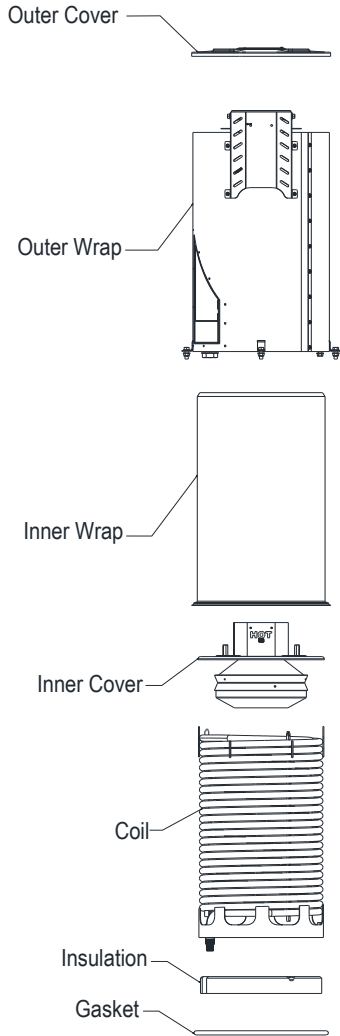

Fig06288

- 9) Lift Using a couple of straps, wrap them around the Coil and attach to a hoist to lift off. You may also use the lifting eyes with hooks to lift with hoist. This coil weighs at least 125 lbs. If no hoist is available, it is recommended that this become a 2-man job each with the ability to lift at least 65 lbs.
- 10) Clean the coil.
- 11) Reassemble the coil and lids to the machine. Make sure the white insulation remains in place.
- 12) Reattach high-pressure hose and thermostat and make sure all fittings are tight before using the machine.

## Inspect/Clean/Adjust Electrodes

Inspect electrodes yearly and replace as needed.

- 1) Loosen front (2) bolts using a 1/2" socket. Loosen side (2) bolts using a 1/2" socket and wrench.
- 2) Remove (3) screws using a 5/32" hex key Allen wrench from the combustion head. Lift off combustion head from outer cover.

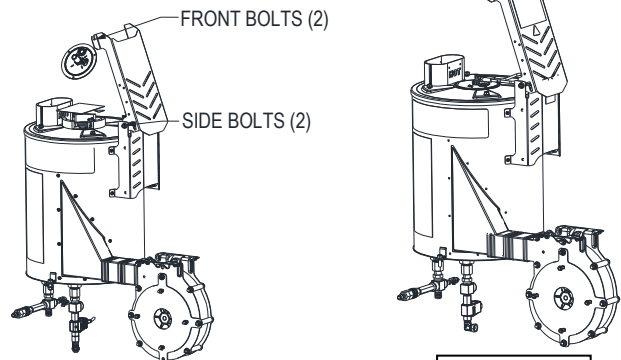

Fig06842

Fig06843

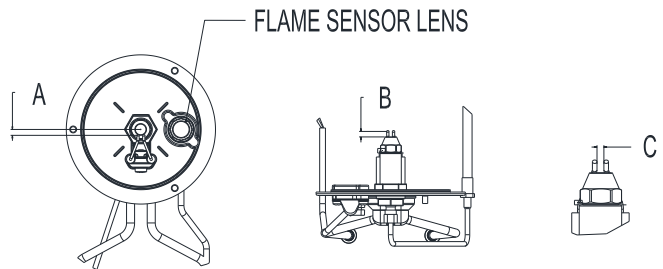

Fig.06172\_1574210

- 3) Disconnect flame sensor and electrode wires. Disconnect fuel line.
- 4) Clean off carbon deposits, which may have accumulated on the tips of the electrodes.
- 5) If electrodes are outside of manufacturing specification, Replace electrodes.

ITEM#	Label dimension		
	A	B	C
1574210	.188	.188	.109
1574211			
1574212			
1574213	.486	.348	.109

**NOTICE:** Wipe combustion head flame sensor lens every 100 hours. If the flame sensor lens gets sooted up the flame sensor will be unable to sense a flame and therefore the burner will not fire. Do not contaminate or touch the fuel nozzle tip.

## Maintenance & Repair

### Instructions for inspecting:

- 1) Remove flame sensor bracket

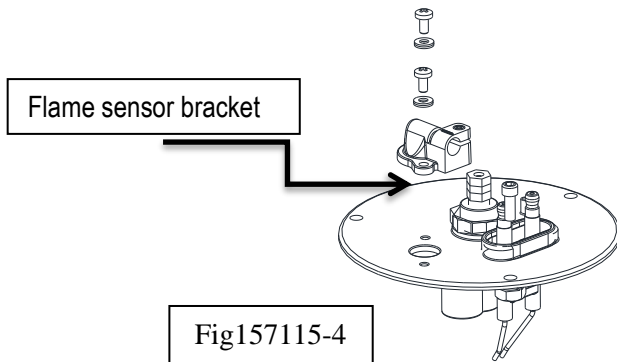

- 2) Following normal starting procedure with burner and thermostat off. With unit running look through flame sensor sight glass to observe if there is a spark.

### Perform Engine Maintenance

All mechanical equipment, no matter how well designed, will need maintenance and repairs. NorthStar Product Support will assist in these repairs as needed, but if an inoperable pressure washer creates a major expense to your business, then we strongly recommend the following:

- Have a staff person become familiar with the mechanical operation of the pressure washer and capable of making minor repairs and performing all preventative maintenance procedures.
- Keep a stock of recommended service parts for maintenance and minor repairs.

#### **IMPORTANT**

If a part needs replacement, only use parts that meet the manufacturer's part number specifications. Replacement parts that do not meet specifications may result in a safety hazard or poor operation of the pressure washer.

**Contact NorthStar Product Support at 1-800-270-0810 for any questions, problems, or parts orders.**

## Oil Burner Adjustment (only needed if white exhaust smoke appears)

The oil burner is preset, and performance tested at factory elevation of 1100 feet. Different altitudes may require a one-time initial burner adjustment.

### CAUTION: Improper fuel-air mixture

If white smoke appears from the burner exhaust vent during start-up or operation, discontinue use and readjust air bands.

Adjusting burner will require accessing it from underneath the pressure washer while someone else is operating the spray gun.

1. Locate the Air intake adjustment cover on blower housing (fig06839) below. Observe the position of the arrow on the cover relative to the calibration numbers. (For unit 1574213 0 is fully closed and 10 is fully open and for units 1574210, 11 & 1574212 0 is fully closed and 9 is fully open).
2. Make sure burner is cool to the touch before attempting adjustments.
3. Begin operation of the pressure washer and switch on the burner, as instructed in the operation section of the manual. Have someone operate the spray gun so the burner ignites.

Note: Typical factory calibration is as follows: 1574210, 1574211 (between 2-5) 1574212 (between 5-7), 1574213 (between 5-8).

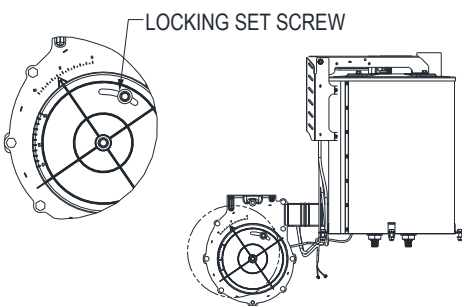

Fig.06839

4. Locate and loosen the locking set screw (fig06839) and rotate the cover clockwise (close) until either of following happens black smoke appears from the burner exhaust vent or a rumbling sound is heard.

Note: which number the arrow is near.

5. Slowly rotate air intake covers counterclockwise (open) until white smoke just starts to appear. Note: If no white smoke appears use fully opened calibration number for reference point.
6. Turn lever halfway back to the black smoke/rumbling sound position previously noted. Tighten the locking set screw.
7. Trigger gun on for 15 seconds and off for 5 seconds. Repeat this cycle 5-10 times. If not large puffs of white smoke are observed inlet air intake adjustment is complete. If large puffs of white smoke are observed on any re-ignitions this could be a sign that the air intake is opened to wide and will need further adjustment.
8. If large puffs of white smoke were observed in step 7, close air intake cover by half a calibration number. (example if calibration number is set to 5 then close intake cover to 4.5)
9. Repeat step 7 & 8 until unit re-ignites without large puffs of white smoke.

## Troubleshooting

### Pressure Washer Will Not Run At All - No Power

<b>Causes</b>	<b>Solutions</b>
Machine turned OFF	Turn Pump switch ON
Line circuit breaker tripped	Check for tripped circuit breaker in building

### Circuit Breaker Trips

<b>Causes</b>	<b>Solutions</b>
Voltage too low	Check the voltage
Circuit Breaker Overloaded	Make sure there is no other equipment using the same circuit.
Pressure set too high	Check/adjust pressure setting on unloader.

### Pressure Washer Runs but Burner Doesn't Fire

<b>Causes</b>	<b>Solutions</b>
<b>Air</b>	
Air intake is blocked or restricted	Inspect & remove any blockages
Air leaking	Inspect rubber boot and connections between the heat exchanger and blower for leaks. Replace boot or tighten connections
Improper air adjustment	See Burner adjustment section of manual
<b>Fuel</b>	
Fuel tank empty	Fill fuel tank with diesel.
Fuel filter water separator is clogged or full of water	Drain or replace if needed
Clogged fuel nozzle	Replace
Fuel pump malfunctioning	Fuel solenoid, coupler, or pump itself may need to be replaced. Contact product support.
	Check fuel pressure and replace if needed
<b>Ignition</b>	
Electrodes damaged or worn	Clean, adjust, or replace electrodes. See maintenance and repair section of manual.
Ignition coil failure or improperly gapped	see maintenance and repair section or contact product support
<b>Other</b>	
Heat switch turned OFF	Turn heat switch ON.
Thermostat set too low or off	Set thermostat to desired temp (if equipped).
Trigger gun is not open	Open Trigger gun to allow flow
Flow switch failed or clogged	Clean or replace flow switch. See Maintenance and repair section of manual
Primary control board malfunctioning	Call Product Support.
Flame sensor	Call Product Support

### Low Pressure

<b>Causes</b>	<b>Solutions</b>
Low water flow	Make sure the water supply is more than 4 gpm
Partially clogged or damaged nozzle	Clean or replace nozzle

### Smoke from Heat Exchanger

<b>Causes</b>	<b>Solutions</b>
Air band not adjusted properly	Adjust the air band until the burner burns cleanly. See installation Instructions.
Poor quality fuel	Use kerosene for the cleanest burn.

## Troubleshooting

### Pressure Washer Runs but Surges or Cycles While In Bypass

<b>Causes</b>	<b>Solutions</b>
Leak between unloader and gun.	Check all connections between unloader and gun for leaks. Tighten loose components and replace damaged components.
Gun leaking internally	Replace spray gun

### Rupture Disc Sprays Water

<b>Causes</b>	<b>Solutions</b>
Pressure Washer/Burner Control Problem	Call Customer Service.

### Poor Or No Detergent Supply

<b>Causes</b>	<b>Solutions</b>
Soap control knob set too low.	Adjust soap control knob
Inadequate detergent supply	Refill detergent container. Make sure the chemical strainer is fully submerged
High pressure hose too long	Use less hose. Move machine closer to the work.
Chemical strainer or hose clogged	Clean the strainer. Always start with a clean detergent container
Clogged injector	Clean injector check valve or replace injector. Run clean water through the injector after each use.

# Major Components

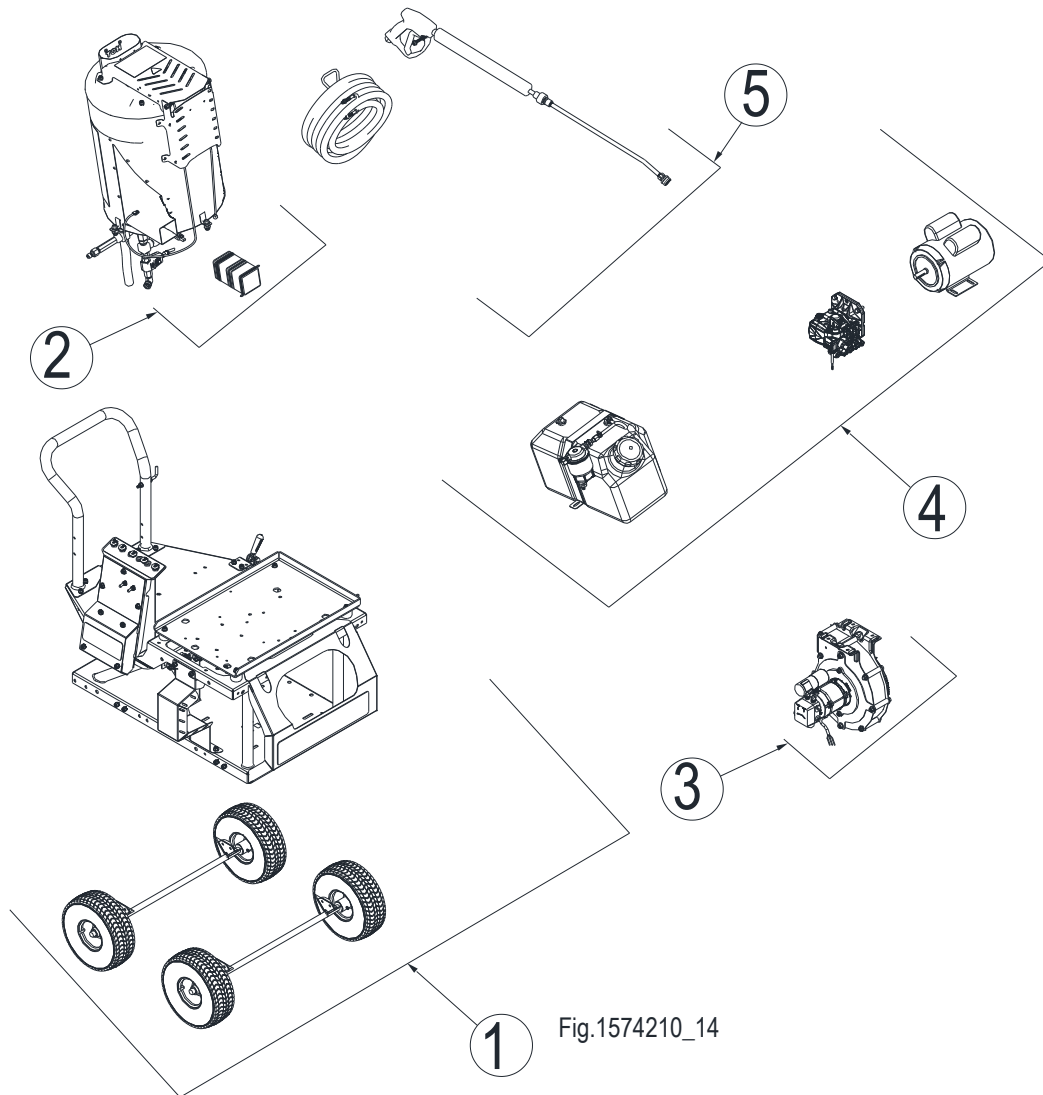

## MAJOR COMPONENTS

Ref.#	Description	Page#
1	Frame	53
2	Heat Exchanger	56
3	Blower and Fuel Pump	59
4	Motor, water pump and fuel system	60
5	Accessories- Gun, hose, chemical injector	62

These components go into more detail on the following pages.

# Parts Explosion: Frame

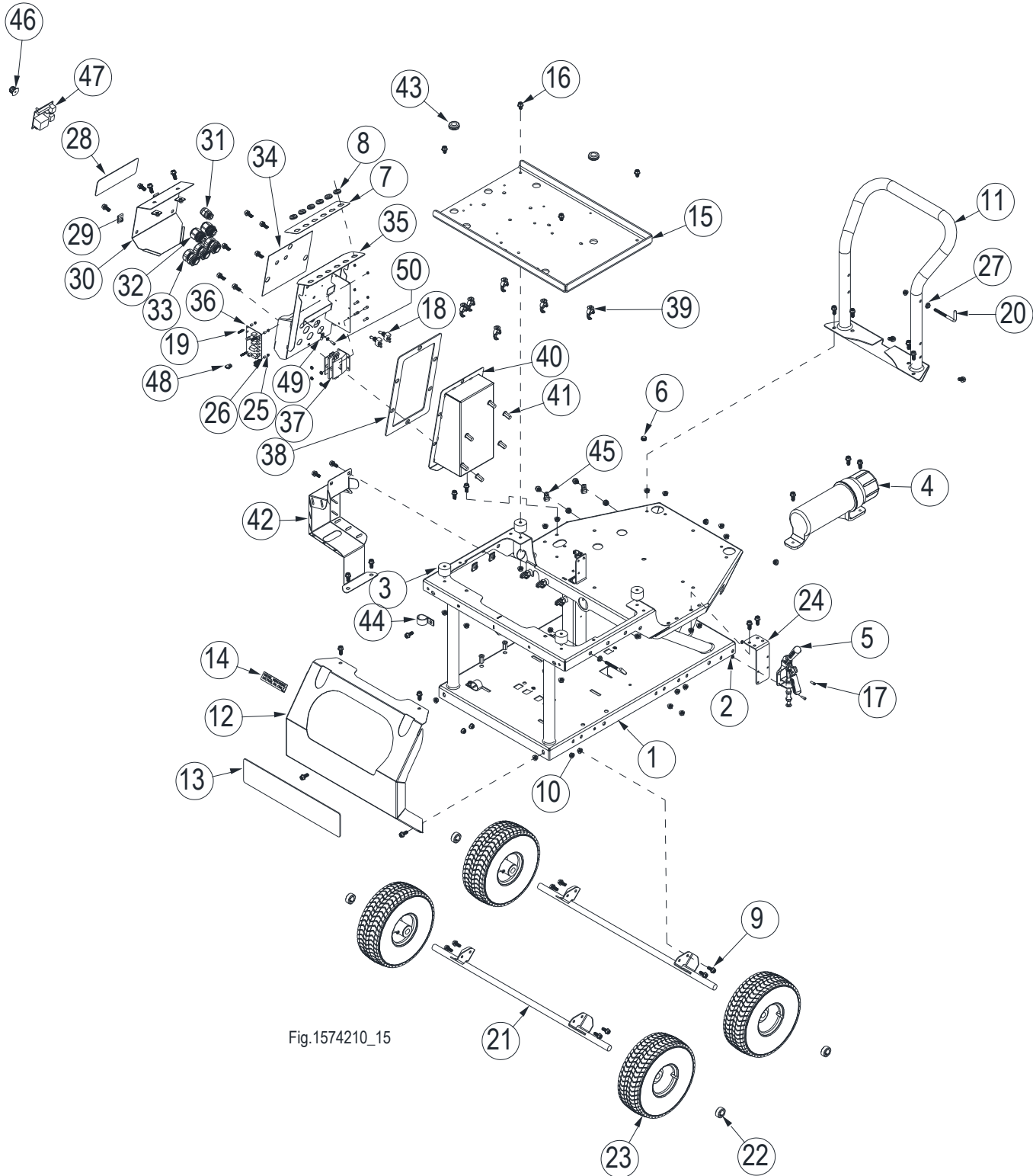

Fig.1574210\_15

## Parts List: Frame

ITEM	PART#	DESCRIPTION	QTY	MODEL
1	799967	CORE WELDMENT	1	All
2	82008	NUT, 10-32 KEPS	6	All
3	800619	ISO MOUNT	4	All
4	788040	MANUAL TUBE	1	All
5	799875	BRAKE	1	All
6	777838	HEX PLUG, 1/4" C. SUNK	1	All
7	800663	DECAL, NOZZLE OPTIONS	1	All
8	35198	GROMMET,7/16 ID-.125	6	All
9	82621	5/16-18 X .75 HHFB	42	1574210, 11, 13
	82621	5/16-18 X .75 HHFB	38	1574212
	82624	BOLT 3/8-16 X1"HEX HEAD FLANGE	4	1574212
10	82630	5/16 FLANGE NYLOC NUT	35	1574210, 11, 13
	82630	5/16 FLANGE NYLOC NUT	31	1574212
	82631	NUT, 3/8-16 HEX FLANGE NYLON	4	1574212
11	800080	HANDLE WELDMENT	1	All
12	800483	BUMPER	1	All
13	788999	LABEL, AC NORTHSTAR, NARROW	1	All
14	801056	DECAL, DIESEL ONLY SMALL	1	All
15	802744	PLATE- PW	1	All
16	82014	5/16"-18 X 1/2" HHSF BOLT	4	All
17	82006	BOLT, #10-32 X 1/2" SHCS	7	All
18	777855	SWITCH, TOGGLE	2	All
19	87435	BOLT, 4-40 x 3/4" PHIL PAN ZN	4	1574210
	87435	BOLT, 4-40 x 3/4" PHIL PAN ZN	8	1574211, 12, 13
20	38509	HOOK, THREADED GUN	2	All
21	800432	WELDMENT, AXLE 30"	2	All
22	305200	RETAINER, WHEEL - PW, TE	4	All
23	788813	TIRE	4	1574210, 11
	778295	TIRE, VALLEY TURF -PW	4	1574212, 13
24	800593	BRAKE MOUNT	1	All
25	87961	4-40 NYLON INSERT LOCK NUT	8	All
	87961	4-40 NYLON INSERT LOCK NUT	16	1574211, 12, 13
26	800186	SPACER, NYLON #4	4	All
	800186	SPACER, NYLON #4	8	1574211, 12, 13
27	82019	NUT, 5/16-18 SER. FLANGE	2	All
28	803144	DECAL, OP INSTRUCTIONS-	1	All
29	82720	5/16-18 BLACK SHORT EXTRUDED U NUT	8	All
30	802983	PLATE, CONTROL BOX WIRE COVER - PW	1	All
31	22502	STRAIN RELIEF	1	1574210, 11
	22502	STRAIN RELIEF	3	1574212, 13
32	803128	STRAIN RELIEF, 3/4" (.276-.511") - PW	2	1574210, 11
	803129	STRAIN RELIEF, 3/4" (.492-.709") - PW	2	1574212, 13
33	803127	STRAIN RELIEF, 3/4" 2 HOLE (.34-.177") - PW	3	1574210, 11
	803127	STRAIN RELIEF, 3/4" 2 HOLE (.34-.177") - PW	2	1574212, 13

## Parts List: Frame

<i>ITEM</i>	<i>PART#</i>	<i>DESCRIPTION</i>	<i>QTY</i>	<i>MODEL</i>
34	803142	DECAL, CONTROL BOX, 1574210 - HWEPPW	1	1574210
	803143	DECAL, CONTROL BOX, 1574211-13 - HWEPPW	1	1574211, 12, 13
35	802979	WELDMENT, CONTROL BOX COVER - PW	1	All
36	801601	CONTROL BOARD, PRIMARY, 110-230VAC - PW	1	All
37	778151	CONTACTOR, DP 120V/25A	1	1574210, 11
	778152	CONTACTOR, DP 230V/30A	1	1574212, 13
38	802746	GASKET, CONTROL BOX HOTWATER	1	All
39	793645	CLIP, HOSE/WIRE	11	All
40	802984	WELDMENT, CONTROL BOX BACK COVER - PW	1	All
41	82651	RIV-NUT 5/16-18 GR .031-.157	8	All
42	802974	PLATE, FUEL/PUMP/MOTOR COVER - PW	1	All
43	789635	GROMMET, 3/16 GW X 1 GD - AC	2	All
44	779666	CLAMP, 1" LOOP	2	1574210, 11, 12
			1	1574213
45	803126	CLAMP, LOOP 5/16	2	1574210, 11
	777110	CLIP, HOSE 1/2" - PW	2	1574212, 13
46	797052	THERMOSTAT KNOB	1	1574211, 12, 13
47	802972	CONTROLLER, TEMP. ASSEMBLY - PW	1	1574211, 12, 13
48	801133	HOUSING, PLASTIC, MOLEX 39-01-2020 - PW	1	All
49	33390	TERMINAL, RING 1/4" - PW	1	All
50	82007	10-32 x 3/4" SHCS	1	All

# Parts Explosion: Heat Exchanger

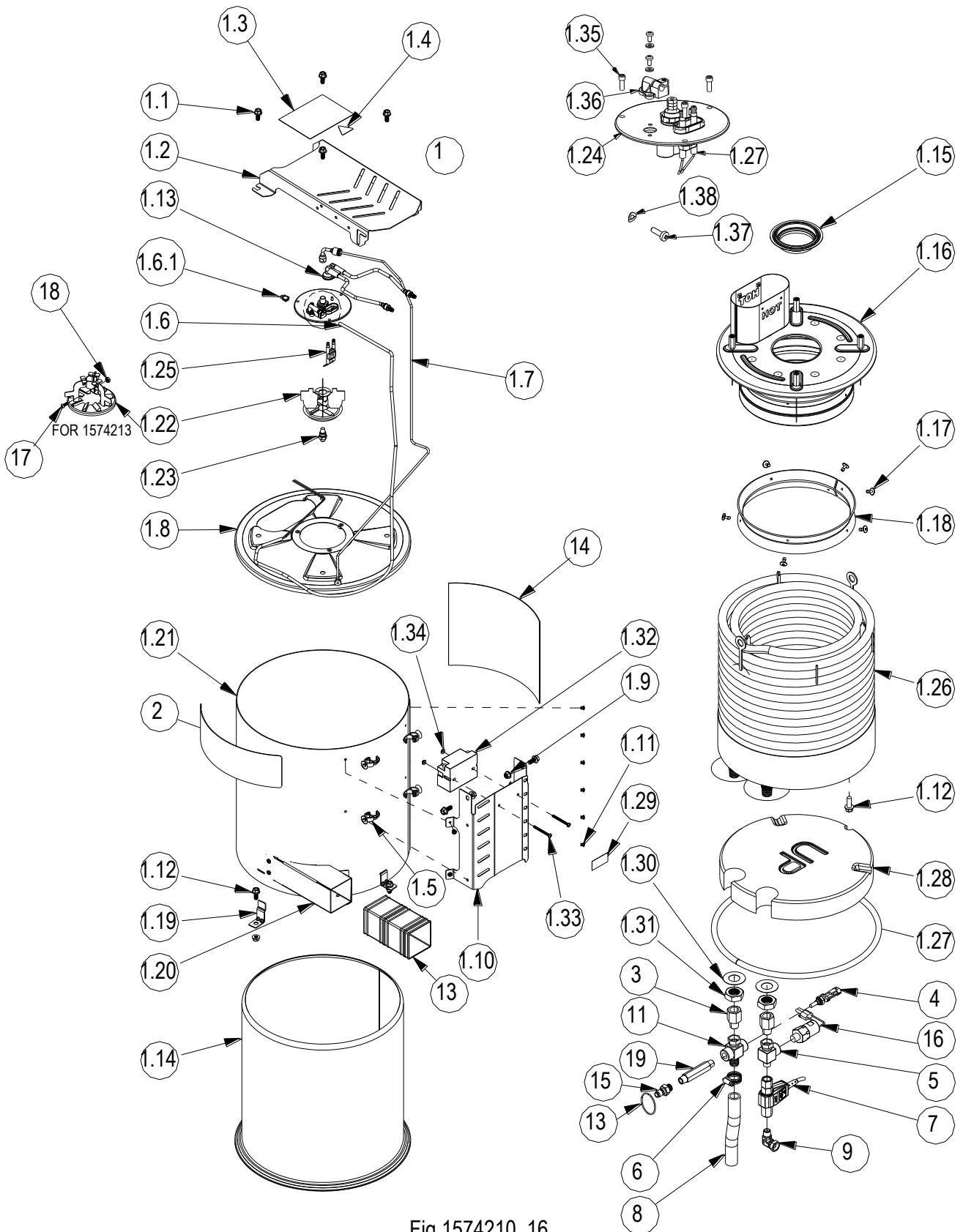

Fig.1574210\_16

## Parts list: Heat Exchanger

ITEM	PART#	DESCRIPTION	QTY	Model
1	N/A	Heat exchanger assembly	1	
1.1	82621	Bolt, 5/16-18 x 3/4" hex head flange	10	1574210, 11, 13
	82621	Bolt, 5/16-18 x 3/4" hex head flange	6	1574212
1.2	796266	Fuel line guard, top	1	1574210, 11, 12
	797692	HX Fuel Line Guard, Top	1	1574213
1.3	798383	Decal, Flame Sensor Lens Cleaning Instructions	1	All
1.4	796496	Decal, Electrical Shock Hazard	1	All
1.5	793645	Clip, hose/wire	4	All
1.6	803105	Flame sensor	1	All
1.6.1	801133	Housing, Plastic, Molex 39-01-2020	1	All
1.7	803032	Fuel line	1	All
1.8	797037	Outer cover weldment, LG vent	1	1574210, 11, 12
	797663	Outer cover XL	1	1574213
	82630	Nut, 5/16-18 nylon insert lock	6	1574210, 11, 13
1.9	82630	Nut, 5/16-18 nylon insert lock	2	1574212
	82631	Nut, 3/8-16 hex flange nylon	4	1574212
1.10	797649	Fuel line guard, side	1	All
1.11	82649	Blind rivet, 3/16"	14	1574210, 11
			21	1574212, 13
1.12	82624	Bolt, 3/8-16 x 1" hex head flange, Gr. 5	1	1574210, 11, 13
	82624	Bolt 3/8-16 x 1" hex head flange, Gr. 5	5	1574212
1.13	792262	High Tension Lead Wires	1	All
1.14	792130	Inner wrap,	1	1574210, 11
	792131		1	1574212, 13
	795761	Ring, air jacket 80mm	1	1574210, 11
1.15	792283	Air Jacket Ring, 89mm x 24.3 mm	1	1574212
	795764	Air Jacket Ring, 98mm	1	1574213
1.16	796702	Inner cover weldment	1	1574210, 11, 12
	798379	Inner cover XL	1	1574213
1.17	82660	Rivet, 3/16 large flange	6	All
1.18	792248	Gasket	1	All
1.19	792135	Hold down bracket	4	All
1.20	802975	Angled intake duct weldment	1	1574210, 11
	797466		1	1574212, 13
	802737		1	1574210
1.21	792124	Outer Wrap	1	1574211
	792126		1	1574212, 13
1.22	792228	Diffuser 4 FIN 3 INCH.	1	1574210, 11, 12
	796314	DIFFUSER 9 FIN 5.5 gpm	1	1574213
	802973	Fuel nozzle, .75 60A GPH (1.5GPM)	1	1574210, 11
1.23	802067	Fuel nozzle, 1.35 60 A GPH (2.5 gpm)	1	1574212
	799677	Fuel nozzle, 2.00 90 B GPH	1	1574213
1.24	803677	Combustion head assembly	1	All
1.25	799293	Electrodes, HX	1	1574210, 11, 12
	799294	Electrodes, HX+ 5.5	1	1574213
1.26	791882	Coil weldment, 85ft	1	1574210, 11
	791883	Coil w/dt 105 ft.	1	1574212, 13
1.27	792224	Gasket	1	All
1.28	792223	Insulation, firebrick	1	All
1.29	797513	Decal burn hazard	1	All
1.30	82606	Washer, 1" ID x 2" OD copper	2	All
1.31	82605	Nut, 1"-14 jam	2	All
1.32	792260	Igniter 120V	1	1574210, 11
	792261	Igniter, 230 Volt	1	1574212, 13
1.33	82245	Screw	2	All
1.34	82065	10-24 Nylon Insert	2	All
1.35	82006	Screw, 10-32 X 1/2 SHCS Y/Z	2	All
1.36	801064	Flame Sensor Bracket Kit	1	All
1.37	82602	M5-0.8 X 16MM PHMS	1	All
1.38	784489	M5 SINGLE WAVE WASHER	1	All

## Parts List: Heat Exchanger

<i>ITEM</i>	<i>PART#</i>	<i>DESCRIPTION</i>	<i>QTY</i>	<i>Model</i>
2	788999	Label, AC Northstar, narrow	1	All
3	779847	Adapter, 8MP-8FP - PW	2	All
4	800102	Thermostat, Fixed 250°	1	1574210
	793966	NTC Thermistor 10Kohm	1	1574211, 12, 13
5	799855	Fitting, coil inlet manifold	1	All
6	17141	Clamp, 3/4" Hose	1	All
7	797121	Switch, flow 12.0 GPM 5000PSI-PW	1	All
8	800127	Hose, 3/4" rupture disk discharge	1	All
9	797199	Fitting, 3/8" MPTXSFPT elbow	1	All
11	800126	Fitting, coil outlet manifold w/rupture disk	1	All
12	800779	Connector, straight rubber	1	All
13	32821	TFG Lanyard - GN	1	All
14	800661	Decal, Branding	1	All
15	777915	Nipple, QC 3/8, 3/8 FNPT-PW	1	All
16	793964	High pressure Limit Switch	1	All
17	82004	BHCS, 8-32 X 1/2 Y/Z	1	1574213
18	82005	NUT, 8-32 KEPS	1	1574213
19	800096	Fitting, Hex Nipple 4"	1	All

## Parts Explosion: Blower & fuel pump

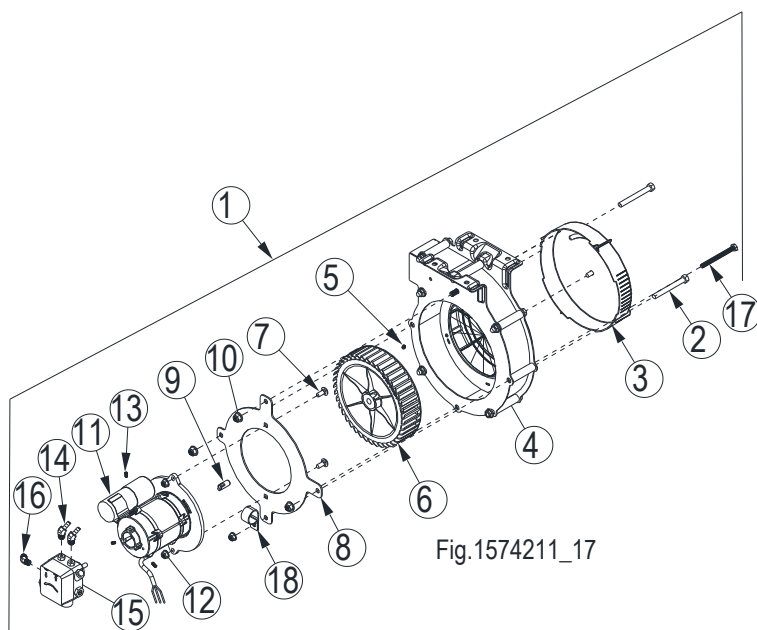

ITEM	PART#	DESCRIPTION	QTY	MODEL
1	N/A	ASSEMBLY FAN & HUB STATOR	1	ALL
2	82109	HHCS, GR5Z 3/8-16 X 3 1/4	3	1574210, 13
	82109	HHCS, GR5Z 3/8-16 X 3 1/4	2	1574211, 12
3	802061	DAMPER, MED CAP - PW	1	1574210, 11, 12
	801874	DAMPER, LARGE CAP - PW	1	1574213
4	801982	ASSEMBLY, AC HOUSING MED. INLET - PW	1	ALL
5	82613	M6-1X8 SET SCREW, KNURLED CUP	1	ALL
6	792268	FAN, 200MM X 47.5MM - PW	1	ALL
7	82088	BOLT, CARR GR5Z 5/16-18 X 3/4	2	ALL
8	792297	MOTOR ADAPTER PLATE, AC - PW	1	ALL
9	795015	COUPLER, PUMP/MOTOR, AC, PW	1	ALL
10	82631	NUT, 3/8-16 HEX FLANGE NYLON	4	1574210, 13
	82631	NUT, 3/8-16 HEX FLANGE NYLON	3	1574211, 12
11	792255	MOTOR, 250-WATT 120VAC	1	1574210, 11
	792256	MOTOR, 250-WATT 240 VAC	1	1574212, 13
12	82630	5/16 FLANGE NYLOC NUT	2	1574213
	82630	5/16 FLANGE NYLOC NUT	3	1574210, 11, 12
13	82612	M5-.8X10 SET SCREW, KNURLED CUP	3	ALL
14	801448	FITTING, 1/4" HB X 1/4" NPT	2	ALL
15	792265	PUMP, 120V FUEL - PW	1	1574210, 11
	792266	FUEL PUMP, 240VAC	1	1574212, 13
15.1	798190	120 VOLT COIL (NOT SHOWN)	1	1574210, 11
15.2	798628	TUBE ASSEMBLY (NOT SHOWN)	1	ALL
15.3	RWB21756U	240 VOLT COIL (NOT SHOWN)	1	1574212, 13
16	794146	FITTING, 1/4" JIC TO 1/8" NPT 45	1	ALL
17	82096	BOLT, 5/16"-18 X 3.5"	1	1574211, 12
18	779666	CLAMP, 1" LOOP	1	1574210, 11, 12

# Parts Explosion: Motor, Water Pump & Fuel System

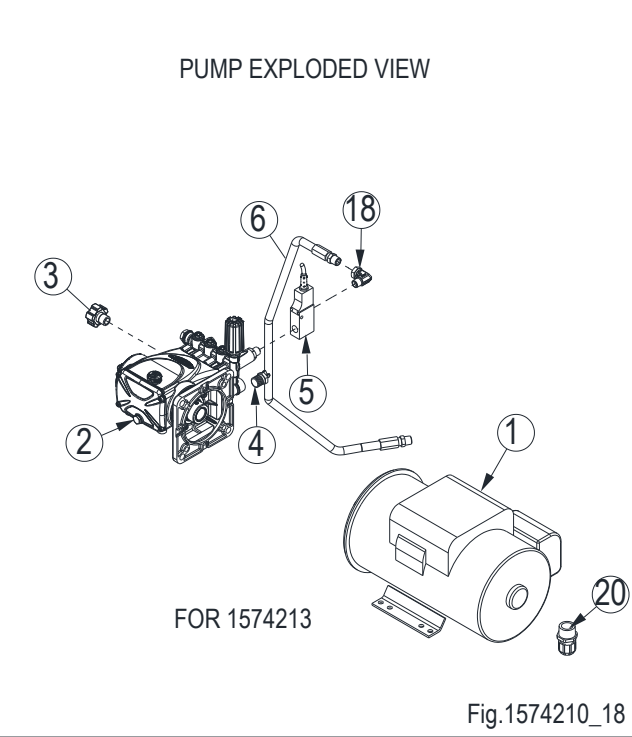
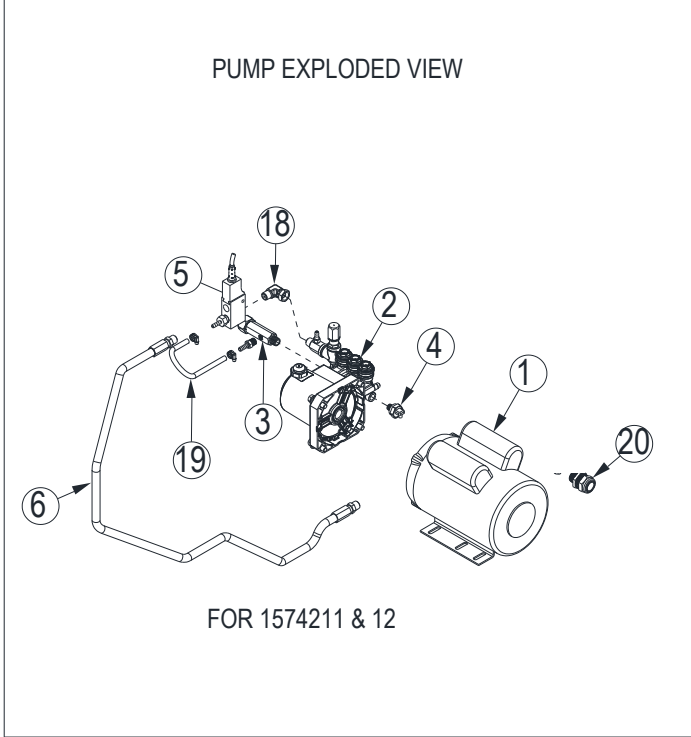
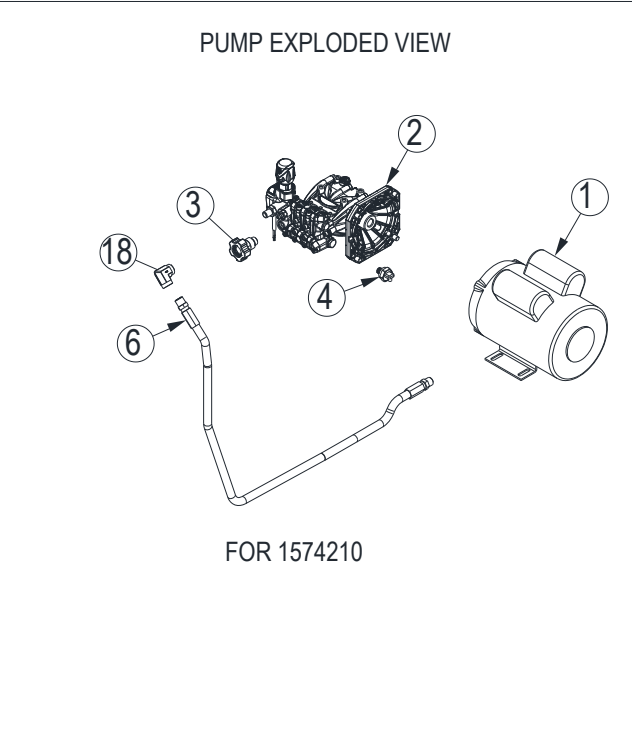
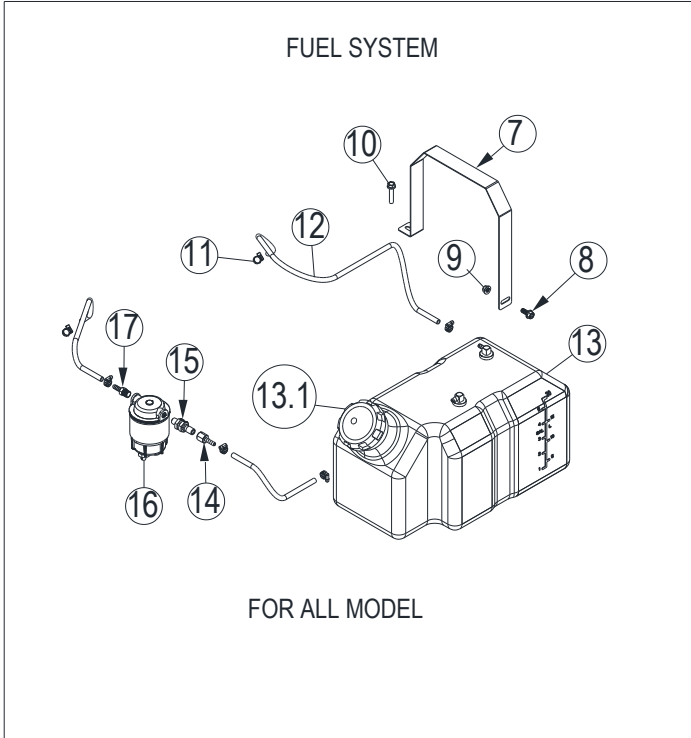

## Parts List: Motor, Water Pump & Fuel System

ITEM	PART#	DESCRIPTION	QTY	MODEL
1	802301	MOTOR, 1.5HP WEG, OPEN DIP PROOF	1	1574210
	803226	MOTOR, 2.0HP 120V, 1PH, 3540	1	1574211
	803875	MOTOR, 5.0HP 230V, 1PH, 3450	1	1574212
	802780	MOTOR, 6.2HP, 230V, 1PH 1750	1	1574213
2	A1574210 82141	PUMP, GP EVO 1.5@ 1700 KEY 3/16 x 3/16 x 1.5" (NOT SHOWN)	1 1	1574210
	A1574211 CA30516	PUMP-CAT 4DX 1.5@2000 KEY AND BOLT MOUNT KIT (NOT SHOWN)	1 1	1574211
	A1574212 CA30516	PUMP-CAT 4DNX 2.5@3000 KEY AND BOLT MOUNT KIT (NOT SHOWN)	1 1	1574212
	A1574213 82141	PUMP-GP EP1812 4@2000 KEY 3/16 x 3/16 x 1.5" (NOT SHOWN)	1 1	1574213
3	803134	FITTING, 3/8" NPT-M TO 3/4" FGH - PW	1	1574210
	30484	BYPASS, 3/8 X 1/4, HEX BRASS(PW)	1	1574211, 12
	800783	FILTER, WASHER, 1/2" NPT X 3/4" FGH	1	1574213
4	35918	PROTECTOR, THERMAL, 1/4 NPT-PW	1	1574210, 11, 12
	777836	PROTECTOR, THERMAL	1	1574213
5	802097	SWITCH, FLOW 12GPM W/ PILOT	1	1574211
	803068	SWITCH, FLOW 12GPM W/ PILOT	1	1574212, 13
6	799879	HOSE, 3/8 x 43" 4000PSI	1	1574210, 11, 12
	798264	HOSE, 3/8 x 31"	1	1574213
7	802412	PLATE, TANK STRAP	1	ALL
8	82621	BOLT, 5/16 X .75 HHFB	1	ALL
9	82630	5/16 FLANGE NYLOC NUT	1	ALL
10	82017	BOLT, 5/16-18 X 1 1/2 HHSF GR5Z	1	ALL
11	777834	CLAMP, 1/4" HOSE	6	ALL
12	801490	HOSE, 1/4" FUEL LINE (CARB 2020)	3.33 ft	ALL
13	800526	TANK, ASSEMBLY W/WITH FUEL CAP	1	ALL
13.1	305206	FUEL CAP	1	ALL
14	796282	FITTING, 1/4" HB X 1/4" FPT	1	ALL
15	795027	FITTING, 1/4" NPT BULKHEAD	1	ALL
16	799864	FILTER, FUEL/WATER SEPARATOR	1	ALL
17	777340	BARB, HOSE BR 1/4 MPT X 1/4(PW)	1	ALL
18	798262	3/8 FPT X 3/8 FPT ELBOW	1	1574210
	797199	FITTING, 3/8" MPTXSFT ELBOW	1	1574211, 12, 13
19	777165	HOSE, 1/4" BRAIDED CHEMICAL	1	1574211, 12
20	803129	STRAIN RELIEF	1	1574212
	803099	STRAIN RELIEF, 1" NPT, 10GA	1	1574213

# Parts Explosion: Accessories: - Gun, Hose, Chemical Injector

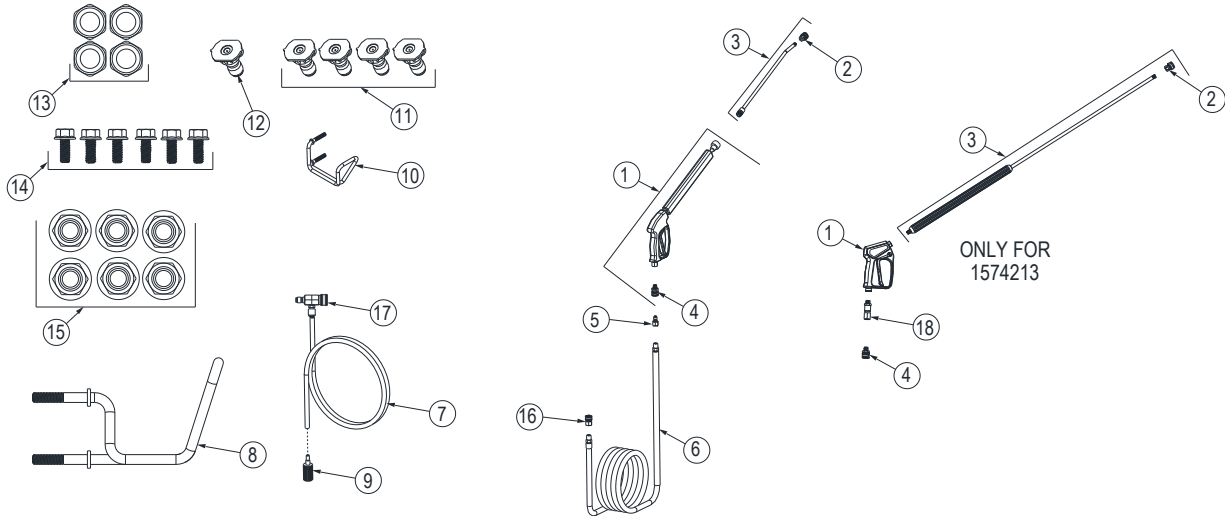
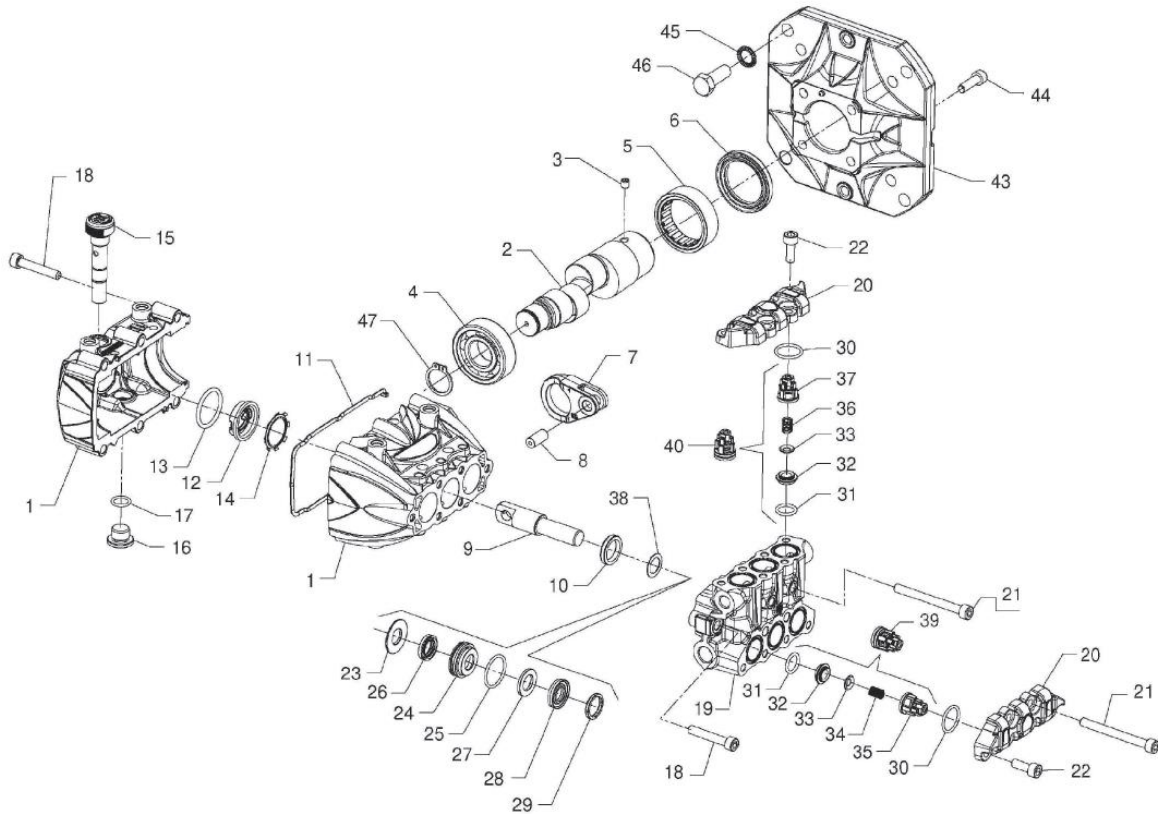

Fig.1574210\_19

ITEM	PART#	DESCRIPTION	QTY	MODEL
1	779165	GUN WITH LANCE	1	1574210, 11, 12
	777420	SPRAY GUN, ST-2605 - PW	1	1574213
2	791274	1/4 QUICK COUPLER	1	ALL
	796379	O-RING (NOT SHOWN)	1	
3	791278	LANCE, 18.5" W/ITON COUPLER	1	1574210, 11, 12
	777421	LANCE	1	1574213
4	780455	3/8" QUICK COUPLE SOCKET X 3/8" MPT	1	1574210, 11, 12
	GP2701020	O-RING (NOT SHOWN)	1	
	777422	SOCKET, 3/8" MNPT SS QC - PW	1	
5	777915	NIPPLE, 3/8"	1	ALL
6	799880	HOSE, 3/8" X 50' HIGH PRESSURE	1	ALL
7	777165	CHEMICAL HOSE	4 FT.	ALL
8	779761	HOSE HOOK	1	ALL
9	221222	STRAINER, CHEMICAL	1	ALL
10	800615	GFCI CORD HOOK	1	ALL
11	803898	NOZZLE 4 PACK, #2.0	1	1574210, 11
	803862	NOZZLE 4 PACK, #3.0	1	1574212
	803864	NOZZLE 4 PACK, #5.5	1	1574213
12	801091	NOZZLE, 15° ORANGE #2.0	1	1574210, 11, 12
	803035	NOZZLE, 15° ORANGE #4.0	1	1574213
13	777495	M8-1.25 NYLOCK NUT	4	ALL
14	82621	BOLT, 5/16-18 x .75" HEX HEAD	6	ALL
15	82630	NUT, 5/16-18 HEX FLANGE NYLOC	6	ALL
16	777914	COUPLING, 3/8"	1	ALL
	GP2701020	O-RING (NOT SHOWN)	1	ALL
17	779613	INJECTOR, QUICK CONNECT 3GPM-PW	1	1574213
18	796634	FITTING, 3/8" GUN SWIVEL EACH	1	1574213

# Pump Exploded-GP PUMP



Ref#	P/N	DESCRIPTION	QTY
1	Not Available	Crankcase	4
2	Not Available	Crankshaft (EM12048EUIITS)	1
3	GP 99179000	Screw, M6x06	1
4	GP91822100	Ball Bearing	1
5	GP91846000	Roller Bushing	1
6	GP90166000	Radial Ring, Ø35.0x47.0x6.0	1
7	GP83030022	Connecting Rod	3
8	GP97730500	Pin, Ø8.0x17.0	3
9	GP83040101	Plunger Assy., Ø12	3
10	GP90158000	Radial Ring, Ø6.0x22.0x4.0	3
11	GP83210747	Gasket, Crankcase	1
12	GP53210851	Oil Level Sight Glass	1
13	GP90385900	O-ring, Ø25.07x2.62	1
14	GP90067100	Stop Ring	1
15	GP98204900	Oil Dipstick	1
16	GP98204150	Screw, G 1/4"x9	1
17	GP701013	O-ring, Ø 10.82x1.78	1
18	GP99192600	Screw, M6x35	8
19	Not Available	Manifold, Ø12	1
20	GP83210013	Valve Cover	2
21	GP99199000	Screw, M6x60	4
22	GP99185400	Screw, M6x16	10
23	GP83210370	Seal Ring, Ø 12	3
24	GP83210270	Gasket Support, Ø 12	3

Ref#	P/N	DESCRIPTION	QTY
25	GP90360000	O-ring, Ø 21.95x1.78	3
26	GP90258950	Seal Ring, Ø 12.0x18.5x4.5	3
27	GP90507080	Anti-extrusion Ring	3
28	GP90258900	Seal Ring, Ø 2.0x21.0x4.2	3
29	GP83100051	Head Ring, Ø 12	3
30	GP90359500	O-ring, Ø 17.17x1.78	6
31	GP90367400	O-ring, Ø 12.00x2.00	6
32	GP36211366	Inlet Valve Seat	6
33	GP36211276	Spherical Inlet Valve	3
34	GP94732600	Spring, Inlet, 6.0x12.0	3
35	GP36211951	Valve Guide, Inlet	3
36	GP94733300	Spring, Outlet, 6.7x10.8	3
37	GP36211151	Outlet Valve Guide	3
38	GP83210851	Ring	3
39	GP36722401	Inlet Valve Assembly	3
40	GP36719301	Outlet Valve Assembly	3
41	GP83210113	Valve Cover, G1/8 opt.	1
42	GP98196800	Plug, G1/8 opt.	1
43	GP10098422	Flange, Electric, 56C	1
44	GP99188400	Screw M6x20	4
45	GP96710400	Washer Ø 10.5x16.0x1.0	4
46	GP99334500	Screw, 3/8"-16x1"	4
47	GP90060500	Anti-extrusion Ring	1

# Pump Exploded-GP PUMP

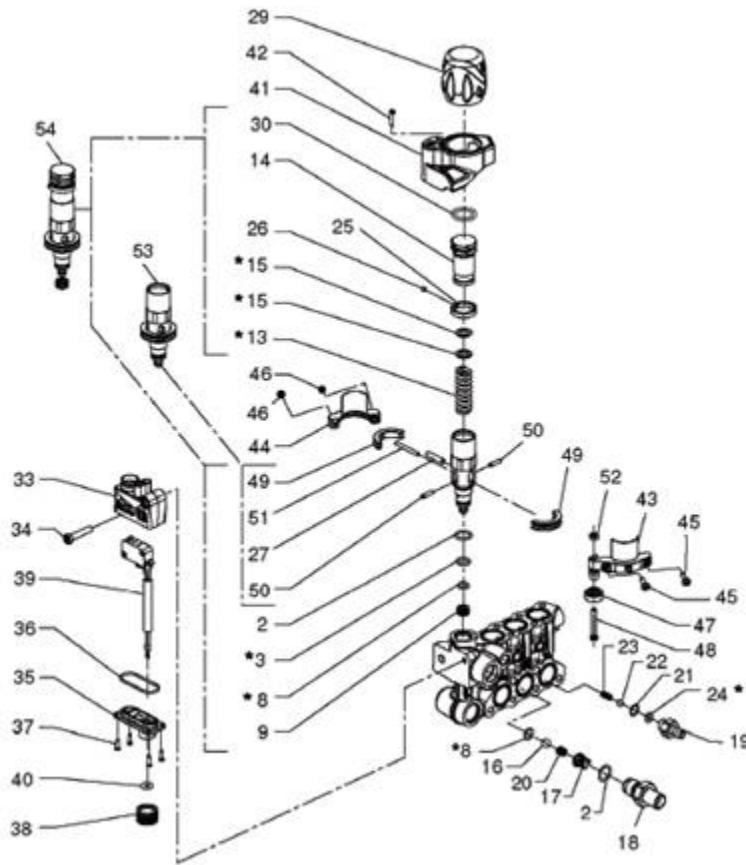

Ref#	P/N	DESCRIPTION	QTY
2	GP90358700	O-ring Ø 1.11x1.78	2
3	GP90358100	O-ring Ø 8.73x1.78	1
8	GP90357600	O-ring, Ø 6.75x1.78	2
9	GP36357100	Valve Seat	1
13	GP94739650	Spring, Ø 11.1x39.5	1
14	GP36356970	Pressure Regulator	1
15	GP36357051	Sliding Washer	2
16	GP97480200	Ball, 9/32"	1
17	GP36356551	Valve Guide	1
18	GP36356870	Nipple, Ø 1.8 G1/4"-M	1
19	GP36357770	Injector	1
20	GP94733250	Spring, 6.2x8.0	1
21	GP90365000	O-ring, Ø 8.00x1.00	1
22	GP97478200	Ball, 7/32"	1
23	GP94730770	Spring, 4.2x13.5	1
24	GP90357300	O-ring, Ø 5.28x1.78	1
25	GP36357670	Maximum Pressure Ring	1
26	GP99070000	Screw, M3x03	1
27	GP97613800	Cylindrical Pin, 4.0m6x20.0	1
28	GP36356770	Nipple, Ø 6.0 G1/4"-M	1
29	GP36356151	Adjustment Knob 1 30	1
30	GP90383700	O-ring, Ø 15.54x2.62	1
31	GP96710000	Washer, Ø 10.0x14.0x1.5	1

Ref#	P/N	DESCRIPTION	QTY
32	GP98196800	Plug, G 1/8"x8	1
33	GP36355951	Box	1
34	GP99159400	Screw, M5x25 7984	1
35	GP36355451	Box Cover	1
36	GP90360800	O-ring, Ø 28.30x1.78	1
37	GP99034400	O-ring, Ø 2.2x9.5 7049	4
38	GP92974100	M14x1.5	1
39	GP10745901	Wiring Switch	1
40	GP90381400	O-ring, Ø 5.23x2.62	1
41	GP36355551	Cover	1
42	GP99072900	Screw, 3x14 9707	1
43	GP36356351	Command Jaw	1
44	GP36356251	Clamping Jaw	1
45	GP99072930	Screw, M3x14	2
46	GP92193000	Nut, Ø M3x2.4	2
47	GP36358847	Bellows	1
48	GP36357465	Regulating Screw	1
49	GP36356651	Semi-disc	2
50	GP97613500	Cylindrical Pin, 3.0m6x12.0	2
51	GP97613700	Cylindrical Pin, 3.0m6x28.0	1
52	GP92192400	Nut, M4x3.2 5588	1
53	GP36607701	Shutter Guide	1
54	GP36607601	Valve Group	1

## Pump Exploded-GP PUMP

### REPAIR KITS:

KIT NO.	GPK309	GPK400	GPK401	GPK402
KIT DESCRIPTION	INLET/OUTLET VALVE ASSEMBLY	GASKET, CRANKCASE	PLUNGER SEAL	PLUNGER SEAL WITH GASKET SUPPORT
ITEM NO'S INCLUDED IN KIT	39, 40	10	25, 26, 27, 28, 29	23, 24, 25, 26, 27, 28, 29
NUMBER OF PIECES	1	1	1	1

# Pump Explosion-CAT 4DX

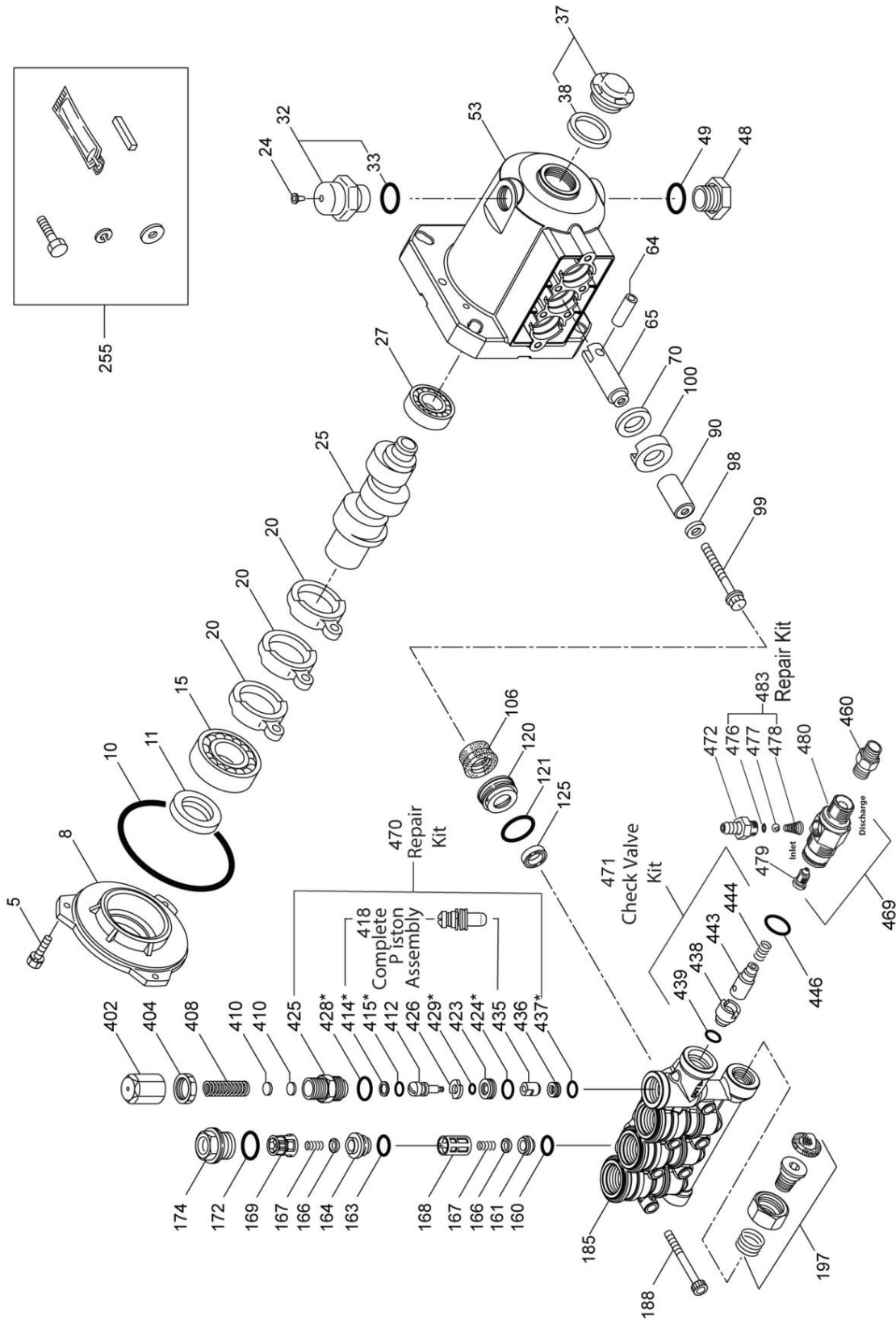

## Pump Explosion-CAT 4DX

Ref#	P/N	DESCRIPTION	QTY
5	<i>Not Available</i>	Screw	3
8	CA547153	Bearing Cover	1
10	CA14041	O-Ring, Bearing Cover	1
11	CA55337	Oil Seal	1
15	CA14488	Inner Ball Bearing	1
20	CA547048	Connecting Rod	3
24	<i>Not Available</i>	Oil Plug Cap	1
25	<i>Not Available</i>	Crankshaft	1
27	CA15710	Ball Bearing	1
32	CA547961	Cap	1
33	CA14179	O-ring for Oil Filter Cap	1
37	CA92241	Gauge, Bubble Oil w/Gasket	1
38	CA44428	Gasket, Flat Flex Oil Gauge	1
48	CA44842	Drain Plug	1
49	CA14179	O-Ring for Drain Plug	1
53	<i>Not Available</i>	Crankcase	1
64	CA46229	Crosshead Pin	3
65	CA132190	Plunger Rod	3
70	CA47215	Oil Seal	3
90	CA542403	Plunger	3
98	CA46730	Washer	3
99	CA542405	Retainer, Plunger	3
100	CA46233	Retainer, Seal	3
106	CA48222	Seal	3
120	CA547357	Seal Case	3
121	CA13976	O-Ring for Seal Case	3
125	CA46240	Seal	3
160	CA13965	O-Ring, Inlet	3
161	CA545177	Seat, Inlet	3
163	CA19285	O-Ring	3
164	CA545178	Seat, Discharge	3
166	CA46764	Valve	6
167	CA46865	Spring	6
168	CA543988	Retainer, Spring, Inlet	3
169	CA49764	Retainer, Spring, Discharge	3
172	CA142807	O-Ring for Plug	3
174	CA547104	Plug, Valve w/O-ring	3
185	<i>Not Available</i>	Head, Manifold w/Unloader Body	1
188	<i>Not Available</i>	Screw	6

Ref#	P/N	DESCRIPTION	QTY
197	CA941516	Inlet Fitting Assembly	1
255	CA30516	Bolt Mount Assembly	1
401	CA32088	Handle Adjustable (Not Shown)	1
402	CA46570	Adjusting Cap	1
404	CA45070	Lock Nut	1
408	CA33394	Pressure Spring	1
410	CA549352	Spring Retainer	1
412	CA46251	Piston Stem	1
414	CA28338	Back Up Ring	1
415	CA22056	O-Ring, Piston Stem	1
418	<i>Not Available</i>	Piston Assy (Included in # 470)	1
423	CA46249	Retainer Valve	1
424	CA13966	O-Ring, Valve Retainer (Outer)	1
425	CA46248	Piston Retainer	1
426	CA46250	Washer	1
428	CA26133	O-Ring	1
429	CA17399	O-Ring, Valve Retainer	1
435	CA548193	Valve	1
436	CA46253	Seat	1
437	CA13963	O-Ring, Seat	1
438	CA46254	Seat, Check Valve	1
439	CA13963	O-Ring, Check Valve Seat	1
443	CA541060	Valve, Check	1
444	CA45924	Spring	1
446	CA26133	O-Ring	1
460	CA107681	Discharge Fitting	1
469	CA7231	Chemical Fixed Injector	1
470	CA76031	Unloader Repair Kit Includes: 418, 428, 436, 437	1
471	CA76146	Check Valve Kit Includes: 438, 439, 443, 444, 446	1
472	CA46630	Barb	1
476	<i>Not Available</i>	Barb O-Ring	1
477	<i>Not Available</i>	Ball	1
478	<i>Not Available</i>	Spring	1
479	<i>Not Available</i>	Orifice	1
480	<i>Not Available</i>	Body	1
483	CA76176	Repair Kit	1
Kit #1	CA33053	Seal Kit Includes: 98, 106, 121, 125	1
Kit #2	CA76978	Valve Kit Includes: 160, 161, 162, 163, 164, 166, 167, 168, 169, 172	1
*	CA76754	O-ring Kit Includes: 414, 415, 424, 428, 429, 437	1

# Pump Explosion-CAT 4DNX

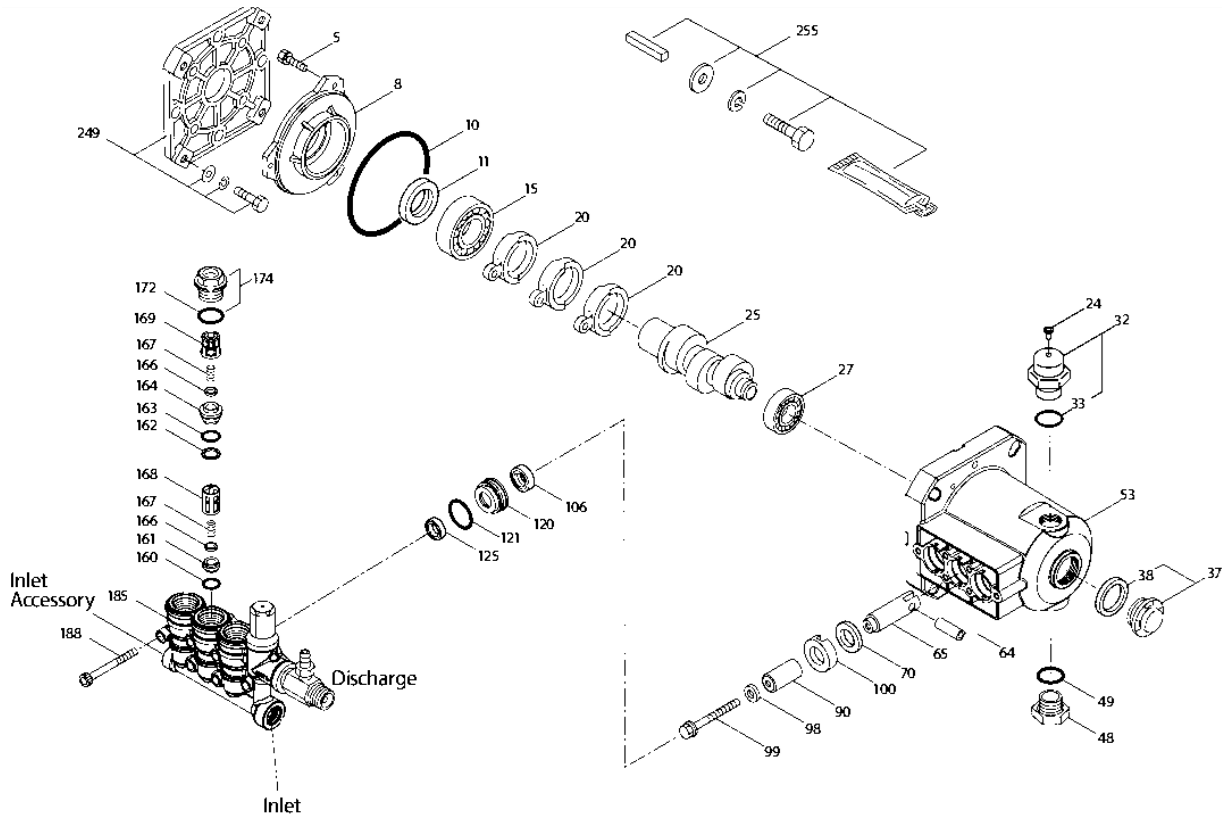

Ref#	P/N	DESCRIPTION	QTY
5	CA549360	Screw	3
8	CA547153	Bearing Cover	1
10	CA14041	O-Ring, Bearing Cover	1
11	CA55337	Oil Seal	1
15	CA14488	Inner Ball Bearing	1
20	CA547048	Connecting Rod	3
24	<i>Not Available</i>	Oil Plug Cap	1
25	CA49883	Crankshaft	1
27	CA15710	Ball Bearing	1
32	CA547961	Cap	1
33	CA14179	O-Ring For Oil Filter Cap	1
37	CA92241	Gauge, Bubble Oil W/Gasket	1
38	CA44428	Gasket, Flat Flex Oil Gauge	1
48	CA44842	Drain Plug	1
49	CA14179	O-Ring For Drain Plug	1
53	<i>Not Available</i>	Crankcase	1
64	CA46229	Crosshead Pin	3
65	CA542402	Plunger Rod	3
70	CA47215	Oil Seal	3
90	CA547091	Plunger	3
98	CA46730	Washer	3
99	CA542405	Retainer, Plunger	3

Ref#	P/N	DESCRIPTION	QTY
100	CA46233	Retainer, Seal	3
106	CA49816	Seal	3
120	<i>Not Available</i>	Seal Case	3
121	CA13976	O-Ring For Seal Case	3
125	CA49824	Seal	3
160	CA17428	O-Ring, Inlet	3
161	CA547077	Seat, Inlet	3
162	CA48361	Back-Up Ring	3
163	CA43358	O-Ring	3
164	CA547076	Seat, Discharge	3
166	CA547098	Valve	6
167	CA46865	Spring	6
168	CA543988	Retainer, Spring, Inlet	3
169	CA49764	Retainer, Spring, Discharge	3
172	CA142807	O-Ring For Plug	3
174	CA547104	Plug, Valve W/O-Ring	3
185	<i>Not Available</i>	Head, Manifold W/Unloader Body	1
188	CA549357	Screw	6
249	CA30520	Adapter Mount Assembly	1
255	CA30516	Bolt Mount Assembly	1
300	CA76975	Seal Kit Includes: 98, 106, 121, 125	1
310	CA76976	Valve Kit Includes: 160, 161, 162, 163, 164, 166, 167, 168, 169, 172	1

# Pump Explosion-CAT 4DNX

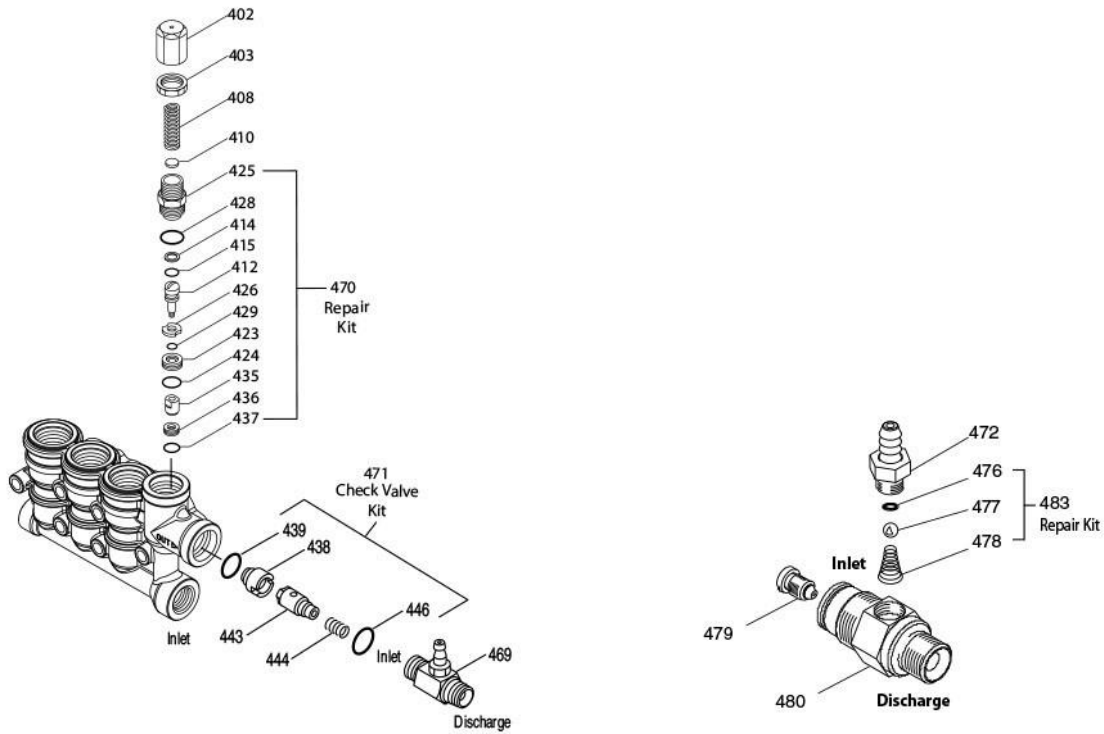

Ref#	P/N	DESCRIPTION	QTY
402	CA547798	Adjusting Cap	1
403	CA45070	Lock Nut	1
408	CA32094	Pressure Spring	1
410	CA549352	Spring Retainer	1
412	CA45694	Piston Stem	1
414	CA20184	Back Up Ring	1
415	CA14190	O-Ring, Piston Stem	1
423	CA46249	Retainer Valve	1
424	CA13966	O-Ring, Valve Retainer (Outer)	1
425	CA547799	Piston Retainer	1
426	CA46250	Washer	1
428	CA26133	O-Ring, Valve Retainer	1
429	CA17399	O-Ring, Piston Retainer (Inner)	1
435	CA547800	Valve	1
436	CA49664	Seat	1
437	CA13963	O-Ring, Seat	1

Ref#	P/N	DESCRIPTION	QTY
438	CA46254	Seat, Check Valve	1
439	CA13963	O-Ring, Check Valve Seat	1
443	CA49765	Valve, Check	1
444	CA45924	Spring	1
446	CA26133	O-Ring, Body	1
468	CA31767	O-Ring Kit Includes: 414, 415, 424, 428, 429, 437, 439, 446	1
469	CA7332	Chemical Fixed Injector	1
470	CA76179	Unloader Repair Kit Includes: 412, 414, 415, 423, 424, 425, 426, 428, 429, 435, 436, 437	1
471	CA76146	Check Valve Kit Includes: 438, 439, 443, 444, 446	1
472	Not Available	Barb	1
476	Not Available	O-Ring, Barb -70d	1
477	Not Available	Ball	1
478	Not Available	Spring	1
479	Not Available	Orifice	1
480	Not Available	Body	1
483	CA76176	Kit, Repair (Includes: 476, 477, 478)	1

# Pump Exploded View – GP EP1812 PUMP

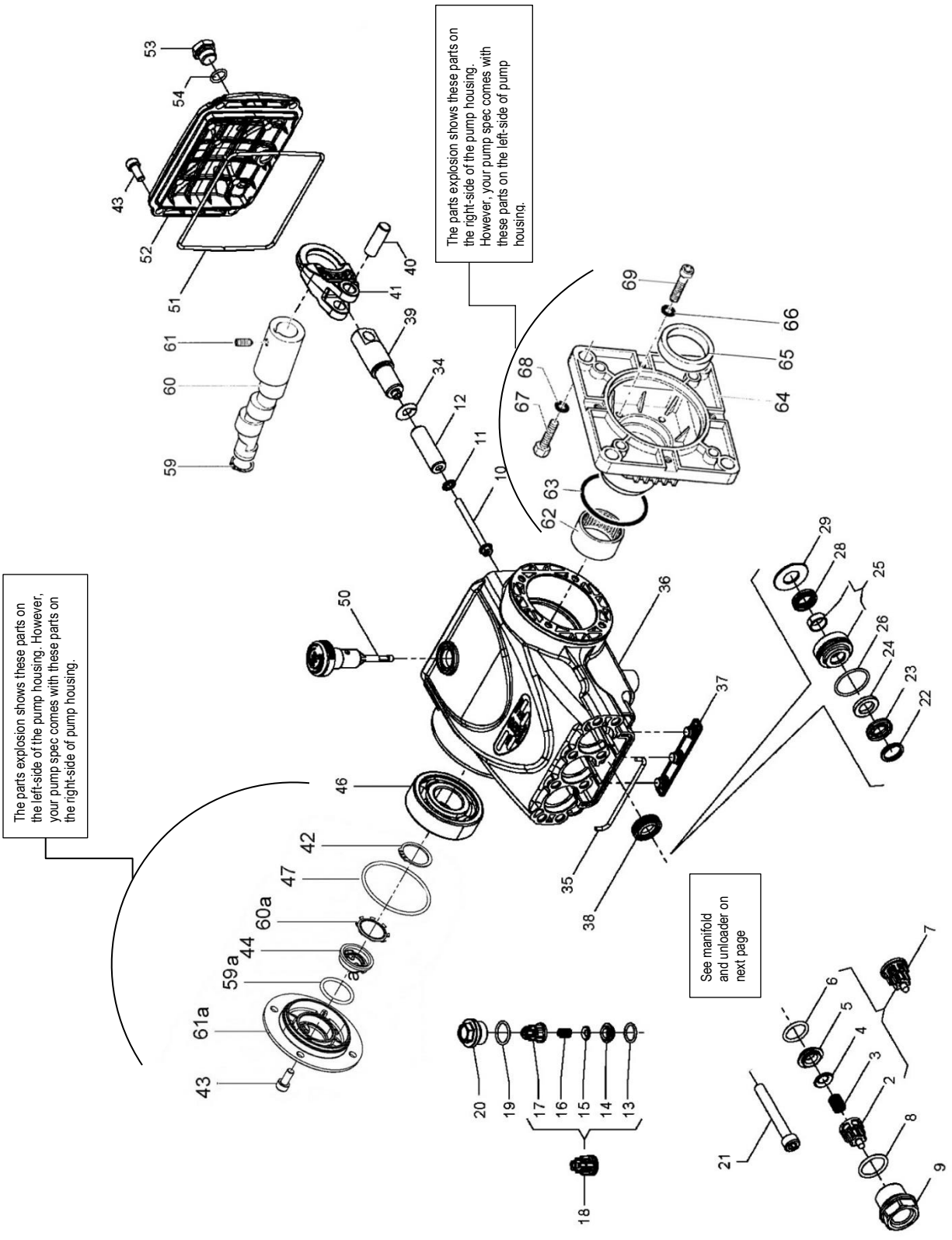

## Pump Parts List – GP EP1812 PUMP

Ref#	P/N	DESCRIPTION	QTY
2	GP36202551	Valve Cage	3
3	GP94737600	Spring, Ø 9.4x14.8	3
4	GP36711501	Valve	3
5	GP36200366	Valve Seat	3
6	GP701115	O-Ring, Ø17.13x2.62	3
7	GP36711501	Valve Assembly	3
8	GP701002	O-Ring, Ø20.24x2.62	3
9	GP98222600	Valve Cap, M24x1.5x16.7	3
10	GP99169000	Plunger Bolt, M5x55	3
11	GP96690500	Washer, Ø 5x11.5x0.4	3
12	GP58040209	Plunger, Ø 18x42	3
13	GP701014	O-Ring, Ø 12.42x1.78	3
14	GP36211366	Outlet Valve Seat	3
15	GP36211276	Outlet Valve Poppet	3
16	GP94733300	Spring, Ø 6.2x10.4	3
17	GP36211151	Outlet Valve Cage Guide	3
18	GP36719301	Complete Outlet Valve	3
19	GP701016	O-Ring, Ø 15.6x1.78	3
20	GP98213700	Outlet Valve Cap, M18x1.5x10	3
21	GP99317500	Screw, M8x60	8
22	Not Available	Head Ring, Ø 18	3
23	Not Available	Packing, Ø 18, Hp	3
24	Not Available	Anti-Ext. Ring, Ø 18	3
25	GP58605801	Intermed. Ring, Ø 18	3
26	Not Available	O-Ring, 26.7x1.78	3
28	Not Available	Seal, Ø 18 Lp	3
29	GP58210870	Support Ring, Ø 18	3

Ref#	P/N	DESCRIPTION	QTY
34	GP96698000	Washer, Ø 7.5x15x0.5	3
35	GP58210582	Gasket, Ø 3x94	1
36	Not Available	Crankcase	1
37	GP58210451	Drip Cover	1
38	GP90156550	Oil Seal, Ø 15x24x5.7	3
39	GP58050066	Piston Guide	3
40	GP97734000	Piston Pin, Ø 10x29.5	3
41	GP58030022	Connecting Rod	3
44	GP44211801	Sight Glass	1
47	GP90409700	O-Ring, Ø 55.56x3.53	1
50	GP98210500	Oil Dipstick	1
51	GP90392550	O-Ring, Ø 113.97x2.62	1
52	GP58160022	Rear Cover	1
53	GP98204100	Plug, 1/4"X9	1
54	GP701013	O-Ring, Ø 10.82x1.78	1
59	GP90063500	Circlip	1
60	Not Available	Crankshaft, 12 Mm	1
61	GP99179000	Set Screw, M6x6	1
62	GP91856800	Needle Bearing	1
63	GP90409700	O-Ring, Ø 55.56x3.56	1
64	GP10050422	Electric Flange	1
65	GP90168700	Oil Seal	1
66	GP203510	Washer, Ø 6.4x10x0.7	4
67	GP99460000	Screw, Hex, 1/2"X1-1/4"	4
68	GP96719500	Washer, Ø 13x18x1.1	4
69	GP99191200	Screw, M6x30	4

### REPAIR KITS:

KIT NO.	GPK269	GPK270	GPK271	Ø 18	
				GPK274	Not Available
ITEM NO'S INCLUDED IN KIT	7 (2, 3, 4, 5, 6), 18 (13, 14, 15, 16, 17)	8, 9, 19, 20	38	22, 23, 24, 26, 28	22, 23, 24, 25, 26, 28, 29
NUMBER OF ASSY'S IN KIT	6	6	3	3	1
NO. OF CYLINDERS KIT SERVICES	3	3	3	3	1

## Pump Parts List – GP EP1812 PUMP

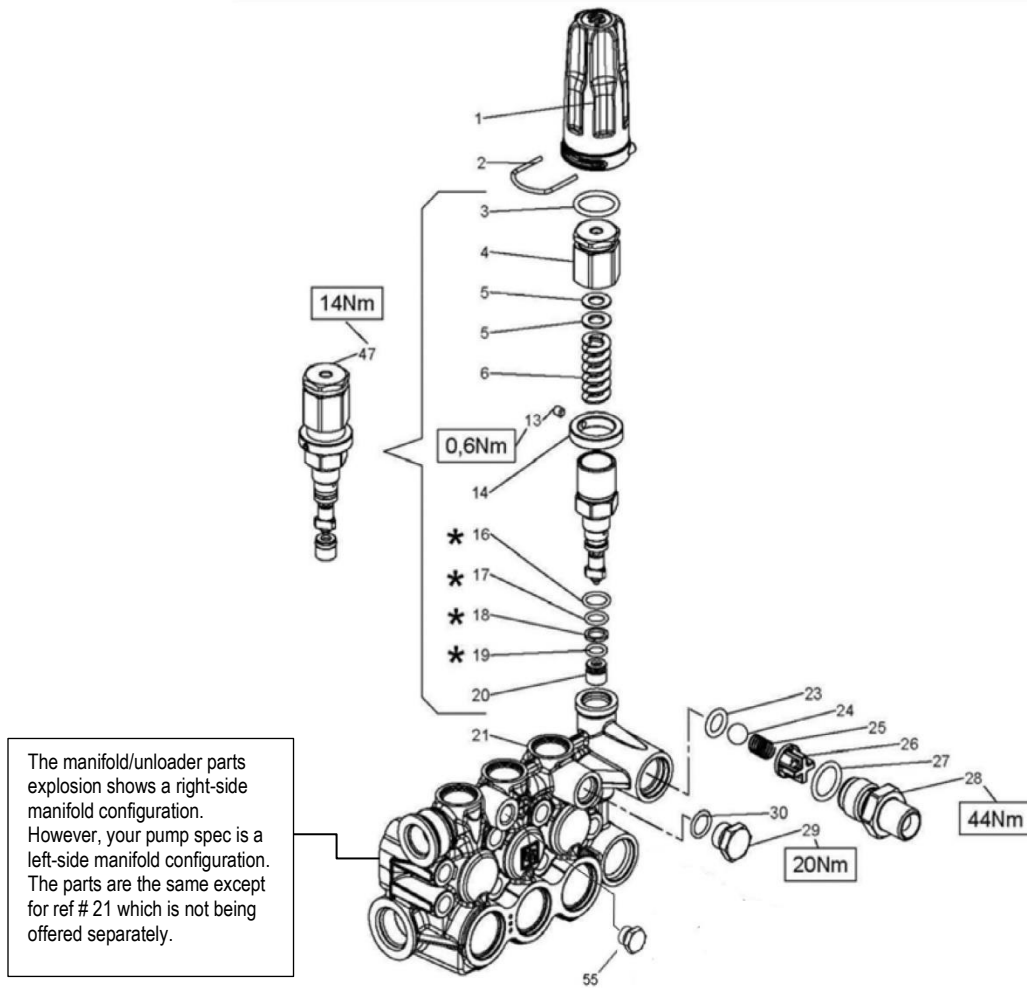

Ref#	P/N	DESCRIPTION	QTY	Ref#	P/N	DESCRIPTION	QTY
1	GP36350651	Adjustment knob	1	20	Not Available	Seat	1
2	GP10084666	Fork for adjustment knob	1	21	Not Available	Manifold, left side unloader	1
3	Not Available	O-ring, Ø18.72x2.62	1	23	GP90382300	O-ring, Ø9.92x2.62	1
4	Not Available	Pressure adjusting nut	1	24	GP97483800	Ball, Ø13/32"	1
5	Not Available	Washer	2	25	GP94735500	Spring, Ø8.2x12	1
6	Not Available	Spring, Ø11.3x34.5	1	26	GP36310451	Valve guide	1
13	Not Available	Screw, M4X5	1	27	GP90383900	O-ring, Ø15.88x2.62	1
14	Not Available	Pressure ring	1	28	GP36348770	Nipple, 3/8" NPT-M	1
16	GP90358700	O-ring, Ø11.11x1.78	1	29	GP98204100	Plug, 1/4"x9 (U)	1
17	GP90358100	O-ring, Ø8.73x1.78	1	30	GP90358500	O-ring, Ø10.82x1.78 (U)	1
18	Not Available	Anti-extrusion ring	1	47	GP36605401	Valve Assembly	1
19	GP90357800	O-ring, Ø7.66x1.78	1	55	GP98196600	Plug, 1/8"x8	1

# Wiring Diagram - 1574210

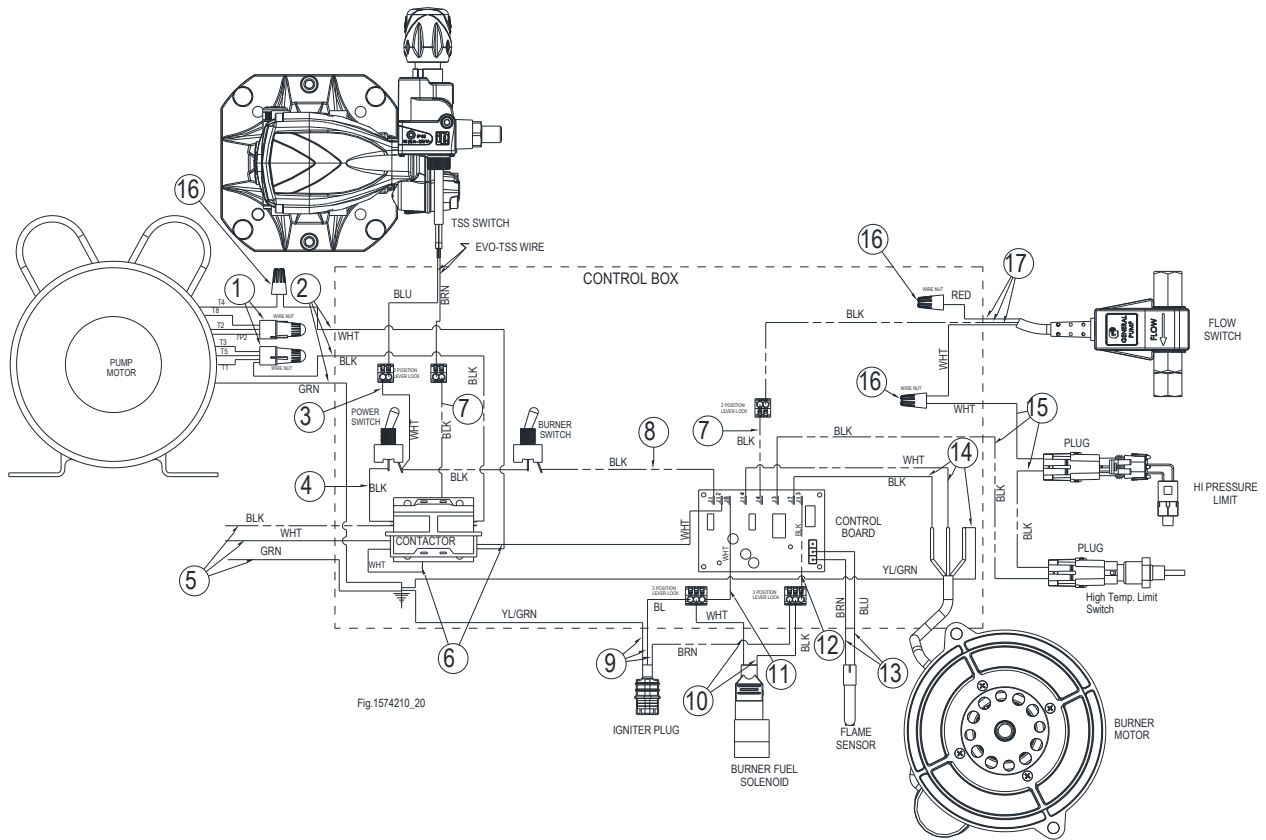

Fig.1574210\_20

Balloon #	Description	Part Number	Qty
1	NUT, WIRE RED - AC 459242	35408	2
2	CORD, MOTOR, 14/3 - HW	802993	1
3	HARNESS, THERMOSTAT - 4 PIN - PW	803321	1
4	WIRE, LEAD BLACK - PW	803322	1
5	CORD, GFCI, 120V/20A, WITH DECAL	803215	1
6	WIRE LEAD, WHITE, PW	778139	2
7	HARNESS, WIRE FLOW SWITCH TO BOARD HWPG	800599	2
8	WIRE LEAD, BLACK, PW	778138	1
9	WIRE HARNESS, POWER SUPPLY IGNITER - PW	803096	1
9.1	RING TERMINAL (NOT SHOWN)	33390	1
10	WIRE HARNESS, FUEL SOLENOID - PW	803095	1
11	WIRE HARNESS, IGNITOR TO FUEL SOLENOID, WHT	802990	1
12	WIRE HARNESS, IGNITOR TO FUEL SOLENOID, BLK	802989	1
13	CORD, FLAME SENSOR - HW	803105	1
13.1	HOUSING, PLASTIC MOLEX 39-01-2020 (NOT SHOWN)	801133	1
14	CORD, MOTOR, 250WATT 120VAC	792255	1
15	WIRE HARNESS, TEMP/HI-PSI LIMIT - PW	802991	1
16	NUT, WIRE	5265	3
17	SWITCH, FLOW 12.0GPM 5000PSI-PW	797121	1

# Wiring Diagram - 1574211

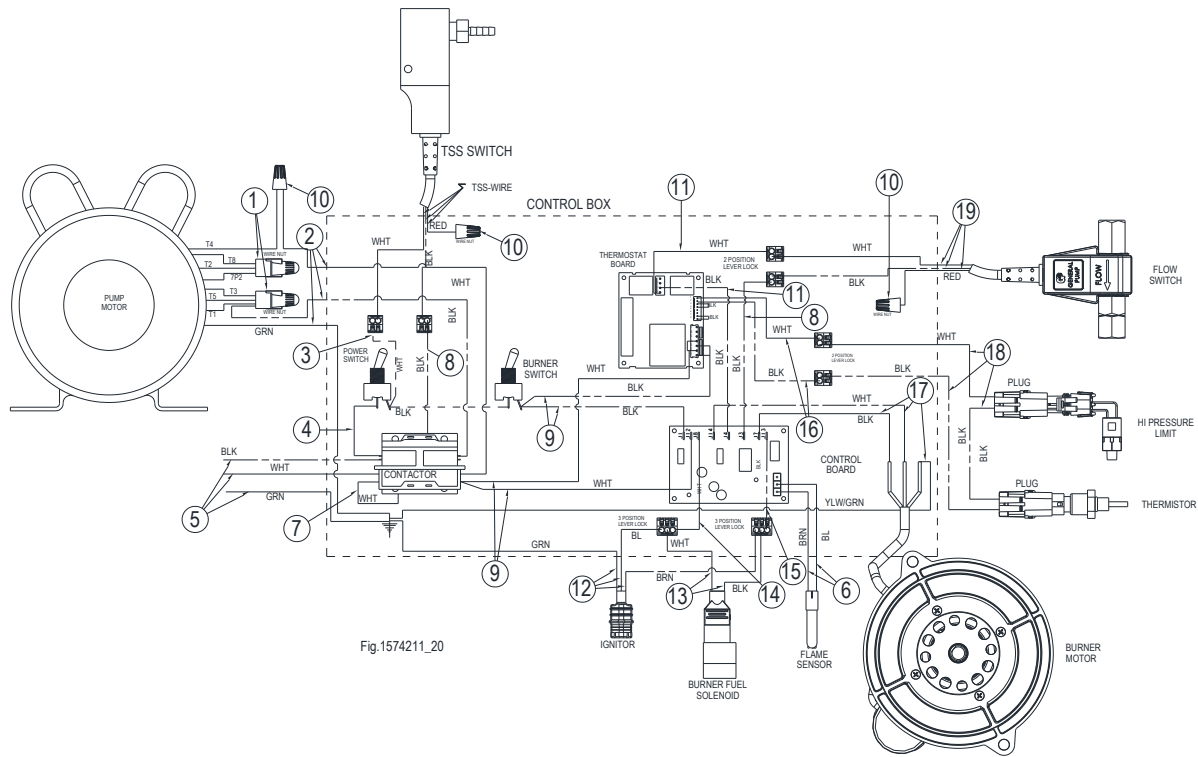
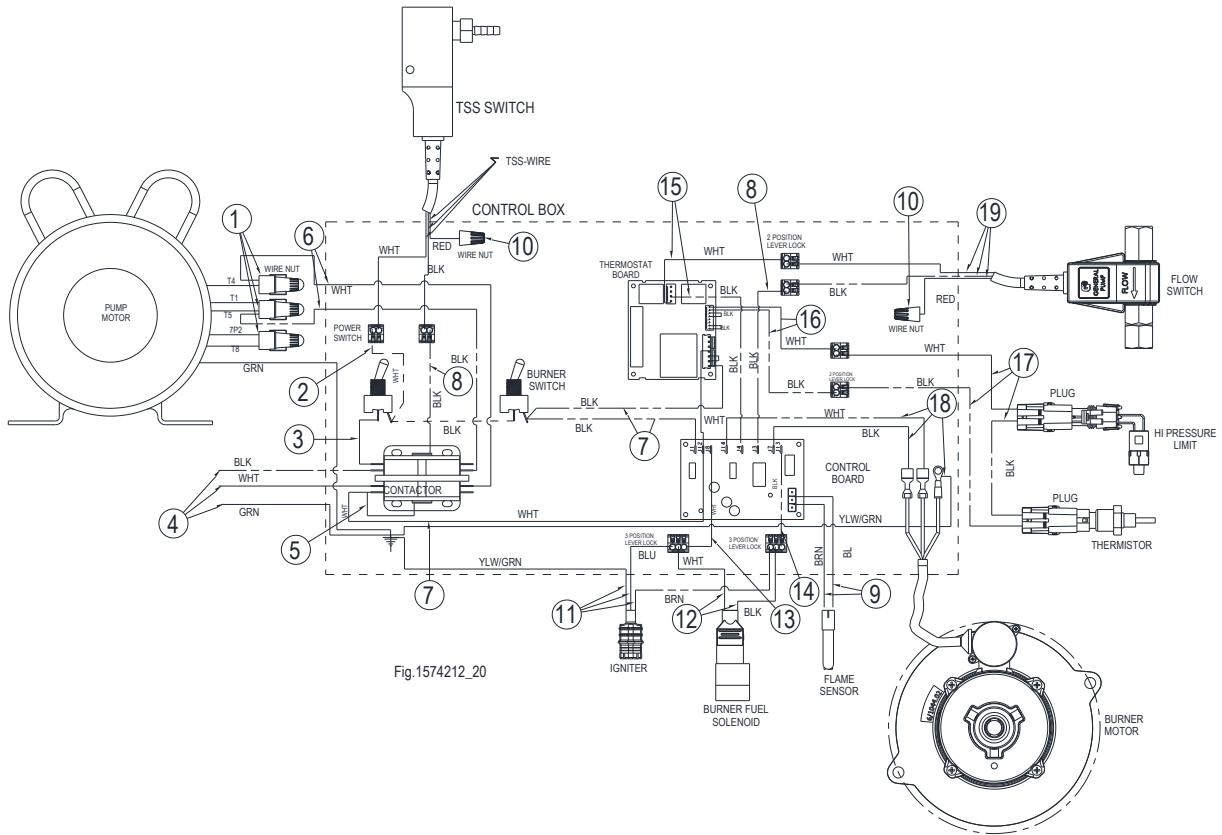

Fig.1574211\_20

Balloon #	Description	Part Number	Qty
1	NUT, WIRE RED - AC 459242	35408	2
2	CORD, MOTOR, 14/3 - HW	802993	1
3	HARNESS, THERMOSTAT - 4 PIN - PW	803321	1
4	WIRE, LEAD BLACK - PW	803322	1
5	CORD, GFCI, 120V/20A, WITH DECAL	803215	1
6	CORD, FLAME SENSOR - HW	803105	1
6.1	HOUSING, PLASTIC MOLEX 39-01-2020 (NOT SHOWN)	801133	1
7	WIRE LEAD, WHITE, PW	778139	1
8	HARNESS, WIRE FLOW SWITCH TO BOARD HWPG	800599	2
9	WIRE HARNESS, THERM POWER, 120VAC - PW	802987	1
10	NUT, WIRE	5265	3
11	WIRE HARNESS, 4 PIN THERM BOARD - HW	803100	1
12	WIRE HARNESS, POWER SUPPLY IGNITER - PW	803096	1
12.1	RING TERMINAL (NOT SHOWN)	33390	1
13	WIRE HARNESS, FUEL SOLENOID - PW	803095	1
14	WIRE HARNESS, IGNITOR TO FUEL SOLENOID, WHT	802990	1
15	WIRE HARNESS, IGNITOR TO FUEL SOLENOID, BLK	802989	1
16	WIRE HARNESS, 8 PIN THERM BOARD - PW	802999	1
17	CORD, MOTOR, 250WATT 120VAC	792255	1
18	WIRE HARNESS, TEMP/HI-PSI LIMIT - PW	802992	1
19	SWITCH, FLOW 12.0GPM 5000PSI-PW	797121	1

# Wiring Diagram – 1574212 & 13



Balloon #	Description	Part Number	Qty
1	NUT, WIRE RED - AC 459242	35408	2
2	HARNES, THERMOSTAT - 4 PIN - PW	803321	1
3	WIRE, LEAD BLACK - PW	803322	1
4	CORD, GFCI,240V,10AWG,WITH DECAL	803216	1
5	WIRE LEAD, WHITE, PW	778139	1
6	CORD, MOTOR, 10/3 - HW	802994	1
7	WIRE HARNES, THERM POWER, 240VAC - PW	802988	1
8	HARNES, WIRE FLOW SWITCH TO BOARD HWPG	800599	2
9	CORD, FLAME SENSOR – HW	803105	1
9.1	HOUSING, PLASTIC MOLEX 39-01-2020 (NOT SHOWN)	801133	1
10	NUT, WIRE	5265	2
11	WIRE HARNES, POWER SUPPLY IGNITER – PW	803096	1
11.1	RING TERMINAL (NOT SHOWN)	33390	1
12	WIRE HARNES, FUEL SOLENOID - PW	803095	1
13	WIRE HARNES, IGNITOR TO FUEL SOLENOID, WHT	802990	1
14	WIRE HARNES, IGNITOR TO FUEL SOLENOID, BLK	802989	1
15	WIRE HARNES, 4 PIN THERM BOARD - HW	803100	1
16	WIRE HARNES, 8 PIN THERM BOARD - PW	802999	1
17	WIRE HARNES, TEMP/HI-PSI LIMIT - PW	802992	1
18	MOTOR, 250WATT 240 VAC	792256	1
19	SWITCH, FLOW 12.0GPM 5000PSI-PW	797121	1

## Summary of Important Safety Information

This section provides a summary of the various safety procedures and measures that have been presented throughout the manual. Keep this summary handy and refer to it to refresh your memory about how to safely use your pressure washer.

### WARNING

Carefully read and understand the following safety information before using the pressure washer. Improper use or maintenance of the pressure washer can result in **serious injury or death** to the operator or bystanders from:

- **Carbon monoxide poisoning**
- **Fire/explosion**
- **Chemical exposure**
- **Skin/eye injury from high pressure spray**
- **Burns**
- **Slips/falls**
- **Electric shock**
- **Flying objects/debris**

### GENERAL

- **Read all instructions.** Read and understand this Owner's Manual and the Motor Owner's Manual completely before attempting to set-up and use the pressure washer. Serious injury or death can result if safety and other instructions are not followed.
- **Instruct all operators.** The pressure washer's owner must instruct all operators and potential renters in safe pressure washer set-up and operation. Do not allow anyone to operate the pressure washer who has not read the Owner's Manual and been instructed on its safe use. Owner's Manuals are available from NorthStar at 1-800-270-0810.
- **Adult control only.** Only trained adults should set up and operate the pressure washer. Do not let children operate. Pressure washers can generate forces greater than children can control and require judgment beyond what can be expected of children.
- **Under the influence.** Never operate, or let anyone else operate, the pressure washer while fatigued or under the influence of alcohol, drugs, or medication.
- **Understand intended use.** Carefully read about and understand the intended use of this pressure washer. Do not use for other purposes, as unforeseen hazards or equipment damage may result.

### PROHIBITION AGAINST MODIFICATIONS

Never modify or alter the pressure washer in any way or deactivate any safety device. Modifications can create serious safety hazards and will also void the warranty.

- **Fuel/exhaust system.** Never add to or modify the exhaust system, fuel tank, or fuel lines. Carbon monoxide poisoning, fuel leaks, fire or explosion could result.
- **Unloader valve.** Do not attempt to alter the unloader valve's maximum pressure. Excess pressure could cause serious injury from escaping high-pressure fluids and/or pump damage. Any alteration other than turning the adjustment knob will void your warranty.
- **Guards.** Do not operate pressure washer unless all guards and cover shields are in place.

### SAFETY – INSTALLATION & SET-UP

#### Installation / Initial Set-up

- **Level, heat-resistant surface.** Situate pressure washer on a firm, level, and heat-resistant surface with good drainage. Ensure it sits level and will not slide or shift during operation. Block wheels to prevent movement.
- **Prevent carbon monoxide poisoning – Use outside only!** Exhaust fumes from both the Motor and the burner contain carbon monoxide (CO), a poisonous gas you cannot see, smell, or taste. The CO generated by the pressure washer can rapidly accumulate, even in areas that appear to be well ventilated, resulting in dangerous and fatal concentrations within minutes. To prevent dangerous CO build-up:
- ONLY use pressure washer outdoors and at least 20 feet from the home, away from windows, vents, and air intakes, to allow proper ventilation. If you start to feel sick, dizzy, or weak while using the pressure washer, shut off the Motor and get to fresh air RIGHT AWAY.
- NEVER run pressure washer in an enclosed or partially enclosed location such as a building, garage, shed, or vehicle. Running a fan or opening windows will not provide adequate ventilation to prevent dangerous CO build-up.

## Summary of Important Safety Information

- **Adequate ventilation.** The pressure washer needs adequate, unobstructed flow of air to allow for proper combustion and cooling. Situate so there is adequate clearance around pressure washer to allow for airflow – at least 7' from any non-combustible wall or obstruction. Never place any objects against or on top of pressure washer.
- **CO alarms.** Ensure that working, battery-operated or battery back-up carbon monoxide alarms are used in any dwelling/structure that is in close proximity to the running pressure washer.
- **Hot exhaust - fires.** Exhausts from burner can be extremely hot and cause fire. Position pressure washer so burner exhaust is at least 7' away from combustible objects during operation.

### Fuel Safety

Burner fuels are combustible at warm temperatures. You can be burned or seriously injured when handling fuel. Use extreme care when handling fuel, including these preventative measures:

- **Fuel outdoors.** Fill fuel tank outdoors – never indoors. Fuel vapors can ignite if they collect inside an enclosure. Explosion can result.
- **Use approved container.** Never pump fuel directly into fuel tank at gas station. Static charge can build and ignite fuel. Use an UL approved fuel container to transfer fuel.
- **Running / hot Burner.** A hot burner is hot enough to ignite fuel. Never add fuel or remove fuel cap if burner is running or still hot. Allow Burner to cool at least two minutes before adding fuel.
- **Heat / flames / sparks.** Stay away from sources of heat, flame, or sparks while adding fuel.
- **Don't overfill.** DO NOT overfill the fuel tank. Allow at least 1/2" of empty space below the fill neck to allow for fuel expansion.
- **Replace cap.** Replace fuel cap securely before starting.
- **Spills.** Clean up fuel spills immediately. Move pressure washer away from spilled fuel on the ground. Wait 5 minutes for excess fuel to evaporate before starting Motor. Fuel soaked rags should be disposed of properly.
- **On skin / clothes.** If fuel is spilled on your skin or clothes, change clothes and wash skin immediately.
- **Inspect fuel system.** Check fuel tanks and fuel system on a regular basis. Look for signs of leaks, deterioration, chafed or spongy fuel hose, loose or missing fuel hose clamps or damaged fuel tank. Do not start pressure washer until needed repairs have been completed.
- **Fuel storage.** Store fuel in a cool, dry place in an UL-approved, tightly sealed container.

## SAFETY – OPERATION

### Pre-start

- **Review safety rules.** Before each use of this pressure washer, review the "Rules for Safe Operation." Failure to follow these rules may result in serious injury or death.
- **Know how to stop.** Be thoroughly familiar with proper use of the equipment and all controls and connections. Know how to stop the pressure washer and relieve system pressure quickly if needed.
- **Danger: High-pressure fluid injection hazard.** High-pressure fluid spray or discharge from leaks (even pin-sized) or ruptured components can pierce the skin and inject fluid into the body. Injection injury can result in blood poisoning and/or severe tissue damage leading to infection, gangrene and possibly amputation.
- **Check/maintain machine before each use.** Check hoses & fittings for damage and leaks before use. Ensure all components are properly connected. Follow all maintenance instructions specified in pressure washer and Motor manuals.
  - Never operate machine with damaged or missing hoses/parts. Never attempt to repair a high-pressure hose or component. Always replace it with a part that is rated at or above the pressure rating of this machine.
  - Never run the machine without sufficient lubrication or sufficient water to cool the pump.
  - Never operate unless all safety guards are in place.

## Summary of Important Safety Information

- **Position safely.** Place sprayer on firm, level ground to prevent accidental falls and equipment tip-over.
- **Not in presence of combustibles.** Do not use the pressure washer in the presence of flammable vapors, dust, gases, or other potentially combustible materials. Operate only where open flame or torch is permitted
- **Use backflow preventer.** The use of a back-flow preventer on the water supply hose is recommended and may be required by local code.
- **Clear work area.** Clear work area of all bystanders. Keep children and pets away.
- **Wear protective gear.** High-pressure spray can cause eye/skin injury, hot water can burn, and flying objects/debris can cause injury. Serious injection injury can result if high-pressure spray penetrates the skin. Operators should wear waterproof, thermally insulated gloves, safety glasses with side and top protection, face protection, and protective clothing when operating the machine. If spraying pressure washer specific cleaning chemicals, wear a respirator or mask to avoid inhalation of vapors if directed on the chemical label.
- **Wear non-slip footwear.** Use of pressure washer can create puddles and slippery surfaces. Wear footwear capable of maintaining a good grip on wet surfaces.
- **Check nozzle.** The nozzle can become a projectile and cause serious personal injury or property damage if not properly connected to the spray gun. Check to ensure the nozzle has been properly attached to the spray gun before using the pressure washer.

### During use

- **Safety latch locked before starting Motor.** Always engage the safety latch on the spray gun trigger before starting the Motor.
- **Incoming water supply on.** Do not run the pump without the water supply connected and turned on. Operating the pressure washer without an incoming flow of water will damage the pump.
- **Wait before re-lighting burner.** NEVER attempt to immediately run or re-light the burner if it doesn't ignite the first time. Unburned fuel may have accumulated, causing potential explosion or fire hazard.
- **Use two hands.** Pressure washer spray gun kicks back when triggered. Firmly grasp with two hands.
- **Stay alert.** Watch what you are always doing.
- **Prevent slips / loss of balance.** High-pressure spray could cause you to lose balance from kickback forces, and wet surfaces can be slippery.
  - Always keep good footing and balance.
  - Do not overreach.
  - Do not stand on unstable support when spraying.
  - Use extreme caution when spraying from a ladder or scaffolding, ensure it is firmly anchored from sway or tip-over. Use extreme caution to avoid falling as spray gun kick can propel you off the ladder or scaffolding.
  - Be aware of puddles and slippery surfaces. Ensure there is adequate drainage to prevent pooling of water.
- **Keep spray away from people.** Never direct discharge stream at or near any person. Do not allow any part of the body to come in contact with the fluid stream. High-pressure spray will cause serious skin, eye, or falling injuries, and hot water can burn. Injection injury will occur if high-pressure spray pierces the skin, injecting liquid under the skin. Injection injury can result in blood poisoning and/or severe tissue damage leading to infection, gangrene and possibly amputation.
- **Prevent surface damage & flying debris** – Surfaces being sprayed must be strong enough to withstand high-pressure spray, or damage may result. In addition, high-pressure spray will dislodge unsecured objects as well as surface chips and debris, resulting in hazardous flying objects that can cause personal injury or property damage. Do not spray brittle surfaces or breakable, fragile, or unsecured objects such as:
  - stucco or laminar flagstone
  - some painted surfaces
  - windows or glass doors (because they may break)
  - light fixtures, flowerbeds, mailboxes
  - unsecured, lightweight objects
- **Do not lock spray gun trigger in ON position.** To reduce risk of injury, do not attempt to secure the spray gun open by blocking or tying the spray gun in the open position.

## Summary of Important Safety Information

- **Keep spray away from electrical wiring.** Spray contact with electrical wiring will likely result in severe electrical shock or electrocution.
- **Use only approved cleaning chemicals.** Only chemicals specifically designed for use in pressure washers may be used. Never spray acids, corrosives, or abrasive or flammable liquids. Breathing hazards, surface burns/corrosion, or fire/explosion could result.
- **Follow cleaning chemical manufacturer's instructions.** Follow the chemical manufacturer's label instructions when handling or spraying chemicals. Understand all safety hazards and first aid for all chemicals being used. Wear protective gear as directed. Always wear protective gloves when handling and cleaning with chemicals. When cleaning filters, check whether dangerous chemicals have been used with the filter and take any precautions that may have been recommended by the supplier of these chemicals. Always dispose of hazardous fluids per local, state, and national guidelines.
- **Do not exceed pressure and or temperature limits.** Do NOT operate this pump with components (such as hose, connections, and spray gun) rated for lower pressure and or temperature limits than the machine's maximum rated pressure and temperature, or component could rupture and cause serious personal injury from escaping high pressure fluids. Do not set the pressure relief device above the rated pressure. **If the high-pressure relief device ever discharges water, turn the Motor off and do not use the machine. Call Product Support at 1-800-270-0810.**
- **Never pull by hose.** Do not move this machine by pulling on the hose. Hose or connections could fail and result in catastrophic high-pressure release of fluid as well as hose whipping.
- **Avoid sharp objects.** Keep hose away from sharp objects. Bursting hoses may cause injury.
- **No load bearing.** Do not use the pump to support other items of equipment that impose unacceptable loads on the pump. Do not attempt to use this machine as a prop.
- **Hot exhaust/parts.** Stay clear of Motor and burner exhausts. Never touch hot Motor muffler, burner/heating coil, or other hot surfaces. All are very hot and will burn you.
- **Hot spray gun metal when using burner.** Never touch the metal screw or any metal parts of the spray gun when the heater is being used – the metal gets very hot and will burn you.
- **Smoking/sparks.** Never smoke near the running Motor, and never operate near sources of sparks or flames as flammable fuel vapors are in the vicinity of the pressure washer.
- **Lock trigger safety latch when not spraying.** Spray gun is equipped with a built-in trigger safety latch to guard against accidental trigger release. Rotate safety latch to the locked position when not spraying.
- **Relieve water pressure.** Always stop the product and relieve system pressure before leaving the sprayer unattended, or when disconnecting hoses, removing nozzles, or servicing the pump.
- **Refueling.** Never add fuel to the burner unless unit is off and has cooled.
- **Do not direct spray at this machine.** Do not attempt to clean this machine with its own spray. Motor damage will result. Cleaning should be done with a damp sponge with the Motor OFF.
- **Seek medical aid for suspected carbon monoxide poisoning.** The running Motor gives off carbon monoxide, a poisonous gas that can kill you. If you start to feel sick, dizzy, or weak while using the pressure washer, shut off the Motor and get to fresh air RIGHT AWAY. See a doctor. You may have carbon monoxide poisoning.
- **Seek medical aid for suspected injection injury.** If injured by high-pressure fluid, no matter how small the wound is, see a doctor at once. A typical injection injury may be a small puncture wound that does not look serious. However, severe infection or reaction can result if proper medical treatment is not administered immediately by a doctor who is familiar with injection injuries.
- **Other exhaust dangers.** This product contains or emits chemicals known to the State of California to cause cancer, birth defects or other reproductive harm. Avoid inhalation of exhaust.

### After use

- **Cool Burner before storing.** Let Motor cool for at least five minutes before storing. A hot Motor is a fire hazard.
- **Prevent accidental starting.** When pressure washer is not in use, move spark plug or spark plug wire in order to ensure that pressure washer cannot be started in a storage location or by untrained persons.
- **Storage location.** Store the pressure washer in a dry location away from sources of heat, open flames, sparks or pilot lights – such as water heaters, space heaters, furnaces, clothes dryers, or other gas appliances – EVEN IF the pressure washer's Fuel tank is empty, residual vapors or fuel could ignite.

## Summary of Important Safety Information

### SAFETY - INSPECTION/MAINTENANCE

Inspect and maintain your pressure washer on a regular basis and repair as needed to keep it in safe working condition:

- **Turn off / relieve pressure first.** Turn off pressure washer and relieve system pressure before inspection or maintenance before working on the Motor or pressure washer to prevent accidental starting.
- **Follow maintenance schedule.** Follow all maintenance instructions in this pressure washer manual.
- **Replace guards / shields.** Make sure all guards and shields are replaced after servicing the pressure washer.
- **Replacement parts.** If a part needs replacement, only use factory approved repair parts. Replacement parts that do not meet specifications may result in a safety hazard or poor operation of the pressure washer and will void the warranty.

# Limited Warranty

Dear Valued Customer:

The NorthStar Product you just purchased is built with the finest material and craftsmanship. Use this product properly and enjoy the benefits from its high performance. By purchasing a NorthStar product, you show a desire for quality and durability. Like all mechanical equipment this unit requires a due amount of care. Treat this unit like the high quality piece of machinery it is. Neglect and improper handling may impair its performance. Please thoroughly read the instructions and understand the operation before using your product. Always contact NorthStar Product Support at 1-800-270-0810 prior to having any service or warranty work performed, as some services performed by parties other than NorthStar approved service centers may void this warranty. This warranty is in lieu of any other warranty expressed or implied and NorthStar assumes no other responsibility or liability outside that expressed within this warranty.

## Limited Warranty

NorthStar shall warranty any piece of equipment manufactured, or parts of equipment manufactured, to be free from defects in material or workmanship for a period of:

NorthStar Warranty		
Item #	Consumer Warranty Period	Commercial Warranty Period
1574210, 1574211, 1574212, 1574213	2 years from date of purchase by user	2 years from date of purchase by user

“Consumer use” means personal residential household use by a consumer. “Commercial use” means all other uses, including use for commercial, income producing or rental purposes or when purchased by a business.

This warranty applies to the original purchaser of the equipment (verification of purchase, in the form of a receipt, is the responsibility of the buyer), is non-transferable, and covers parts and labor. Parts will be replaced or repaired at no charge, except when the equipment has failed due to lack of proper maintenance. If a part is no longer available, the part may be replaced with a similar part of equal function. Any misuse, abuse, alteration or improper installation or operations will void warranty. Determining whether a part is to be replaced or repaired is the sole decision of NorthStar. NorthStar will not provide for replacement of complete products due to defective parts. Any costs incurred due to replacement or repair of items outside of a NorthStar approved facility is the responsibility of the buyer and not covered under warranty. Transportation costs to and from service center is the responsibility of the customer.

In addition to the normal warranty, NorthStar shall warrant any normal wear item from defects in material or workmanship for a period of 90 days from the date of purchase by user. Normal wear items include, but are not limited to, nozzles, quick connect fittings, valves, high- and low-pressure water seals/packing, high and low pressure hoses, O-rings, unloader valves and filter elements.

This warranty specifically excludes the following; failure of parts due to damage caused by accident, fire, flood, windstorm, acts of God, applications not approved by NorthStar in writing, corrosion caused by chemicals, use of replacement parts which do not conform to manufacturer’s specifications, damage related to the use of biodiesel fuel, damage related to rodent and/or insect infestation and damage caused by vandalism. Additional exclusions: loss of running time, inconvenience, loss of income, or loss of use, including any implied warranty of merchantability of fitness for a specific use. Also, Outdoor Power Equipment needs periodic parts and service to perform well, and this warranty does not cover instances when normal use has exhausted the life of a component or the engine.

This warranty does not cover any personal injury or damage to surrounding property caused by failure of any part. Repair or replacement of parts does not extend the warranty period.

Normal burner maintenance such as cleaning and adjusting electrodes, descaling the coil, desooting the coil, air adjustments, fuel system cleaning and obstruction due to build up is not covered by this NorthStar warranty.

Please fill in the following information and have it on hand when you call in on a warranty claim.

Customer Number: \_\_\_\_\_

Date of Purchase: \_\_\_\_\_

NorthStar Serial Number: \_\_\_\_\_

Item Number: \_\_\_\_\_

**⚠ WARNING:** This product can expose you to chemicals including acetaldehyde, which is known to the State of California to cause cancer, and carbon monoxide, which is known to the State of California to cause birth defects or other reproductive harm.

For more information go to [www.P65Warnings.ca.gov](http://www.P65Warnings.ca.gov).



Manufactured by  
Northern Tool + Equipment Co., Ltd  
Burnsville, MN 55306  
NorthernTool.com