



M1573001Y

Item Numbers: 1573001,1573011
1573021

Owner's Manual

Pressure Washer: Machine that cleans dirty surfaces with high pressure water.



⚠ WARNING

Read this manual.

Serious injury or death can result if safety instructions are not followed.

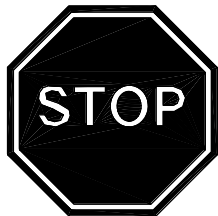

Pump is shipped with oil.

- Remove shipping tape from pump oil fill cap. (Cat Pumps)
- Remove shipping plug and install vented fill cap. (Comet Pumps)
- See pump oil cap section of this manual.

Closely inspect all components.

- If you have damaged components: Contact the freight company that delivered the unit and file a claim.
- If you have missing components: Contact Customer Service at 1-800-270-0810.

fig02342

Any Questions, Comments, Problems or Parts Orders
Call NorthStar Product Support 1-800-270-0810

Hazard Signal Word Definitions





	<p>This is the safety alert symbol. It is used to alert you to potential personal injury hazards. Obey all safety messages that follow this symbol to avoid possible injury or death.</p>
	<p>DANGER (red) indicates an imminently hazardous situation which, if not avoided, will result in death or serious injury.</p>
	<p>WARNING (orange) indicates a potentially hazardous situation which, if not avoided, could result in death or serious injury.</p>
	<p>CAUTION (yellow) indicates a potentially hazardous situation which, if not avoided, may result in minor or moderate injury.</p>
	<p>CAUTION (yellow) used without the safety alert symbol indicates a potentially hazardous situation which, if not avoided, may result in property damage.</p>

fig01453

Table of Contents

Important Safety Instructions.....	4
Grounding Instructions.....	5
Warning Label Locations.....	6
Assembly Instructions.....	7-9
Machine Component Identification.....	10
Pump Component Identification.....	11
Operation Instructions.....	12-15
Water Supply.....	12
Start-Up/Shut-Down Instructions.....	12
Spray Gun Safety Lock and Attaching the Lance.....	13
Installing Nozzles and Quick Connect hoses.....	14
Applying Chemicals.....	15
Maintenance and Storage.....	16-18
Maintenance Mode and Maintenance Schedule.....	16
Pump Oil Change.....	17
Winter Storage.....	18
Troubleshooting.....	19
Specifications.....	20
Wiring Diagram.....	20-21
Parts Explosions.....	22
Pump Exploded Views.....	24-27
Limited Warranty.....	29
California Proposition 65 Information.....	30

Important Safety Instructions

- ⚠ WARNING** - Risk of Injection or Injury to Persons - Do Not Direct Discharge Stream at Persons. - Do not use a hose if exterior damage is evident.
- Risk of explosion. - Do not spray flammable liquids. - Do not operate in a flammable environment.

- CAUTION** - Gun kicks back. Hold with both hands.
- To reduce the risk of injury, read operating instructions carefully before use.

- ⚠ WARNING** - When using this product basic precautions should always be followed, including the following:
- 1.) Read all the instructions before using the product.
 - 2.) To reduce the risk of injury, close supervision is necessary when the product is used near children. Do not allow irresponsible use by children. Always stop the product and bleed pressures before leaving unattended, disconnecting hoses or servicing the pump.
 - 3.) Know how to stop the product and bleed pressures quickly. Be thoroughly familiar with the controls.
 - 4.) Stay alert - watch what you are doing.
 - 5.) Do not operate the product when fatigued or under the influence of alcohol or drugs.
 - 6.) Keep operating area clear of all persons.
 - 7.) Do not overreach or stand on unstable support. Keep good footing and balance at all times. Wear footwear capable of maintaining a good grip on wet surfaces - Do not place the machine on soft or unstable ground.
 - 8.) Follow the maintenance instructions specified in all manuals. Do not run machine without sufficient lubrication or sufficient water to cool the pump.
 - 9.) Wear safety glasses, gloves, face protection and appropriate clothing when operating the machine.
 - 10.) Do not operate this machine with broken or missing parts. - Never alter the manufacturer's original design or deactivate any safety device on the machine.
 - 11.) Risk of exposure to dangerous chemicals. Wear protective gloves when handling and cleaning with chemicals. Follow the chemical manufacturer's directions. Understand all safety hazards and first aid for all chemicals being used. Check whether dangerous chemicals have been used and take any precautions that may have been recommended by the supplier of these chemicals when cleaning filters. Do not pump highly abrasive fluids or use with incompatible chemicals or solvents.
 - 12.) Know the pressure and temperature limits of your machine. Be sure all high pressure accessories meet or exceed your machine's limits. Do not set the pressure relief valve above the machine's limit.
 - 13.) Do not move this machine by pulling on the hose. Do not use the pump to support other items of equipment that impose unacceptable loads on the pump. Do not attempt to use this machine as a prop.
 - 14.) To reduce risk of injury, do not secure the spray gun open. Your spray gun is equipped with a built-in trigger safety latch to guard against accidental trigger release and potentially dangerous high pressure spray. Rotate the safety latch to the locked position when not spraying.
 - 15.) Do not clean this machine with its own spray. Cleaning should be done with a damp sponge with the motor OFF.
 - 16.) Always make sure all switches and controls are in the OFF position prior to plugging in the electrical cord. Do not stand in water while plugging and unplugging electrical cord.
 - 17.) This product is provided with a ground fault circuit interrupter built into the power cord plug. If replacement of the plug or cord is needed, use only identical replacement parts.
 - 18.) Keep a fire extinguisher rated "ABC" nearby.

SAVE THESE INSTRUCTIONS

Grounding Instructions

This product must be grounded. If it should malfunction or breakdown, grounding provides a path of least resistance for electric current to reduce the risk of electrical shock. This product is equipped with a cord having an equipment-grounding conductor and a grounding plug. The plug must be plugged into an appropriate outlet that is properly installed and grounded in accordance with all local codes and ordinances.

⚠ DANGER - Improper connection of the equipment - grounding conductor can result in a risk of electrocution. Check with a qualified electrician or service personnel if you are in doubt as to whether the outlet is properly grounded. Do not modify the plug provided with the product - if it will not fit the outlet; have a proper outlet installed by a qualified electrician. Do not use any type adapter with this product.

1. For a product rated 125 volts or less:

GROUND FAULT CIRCUIT INTERRUPTER PROTECTION

This pressure washer is provided with a ground fault circuit interrupter (GFCI) built into the plug of the power supply cord. This device provides additional protection from the risk of electric shock. Should replacement of the plug or cord become necessary, use only identical replacement parts that include GFCI protection.

2. For a product rated more than 125 volts:

GROUND FAULT CIRCUIT INTERRUPTER PROTECTION

To comply with the National Electric Code (NFPA 70) and to provide additional protection from the risk of electric shock, this pressure washer should only be connected to a receptacle that is protected by a ground fault circuit interrupter (GFCI).

Extension Cords

Use only 3-wire extension cords that have 3 prong grounding-type plugs and 3-pole cord connectors that accept the plug from the product. Use only extension cords that are intended for outdoor use. These extension cords are identified by a marking "Acceptable for use with outdoor appliances; store indoors while not in use." Use only extension cords having an electrical rating not less than the rating of the product. Do not abuse extension cord and do not yank on any cord to disconnect. Keep cord away from heat and sharp edges. Always disconnect the extension cord from the receptacle before disconnecting the product from the extension cord.

⚠ WARNING - To reduce the risk of electrocution, keep all connections dry and off the ground. Do not touch plug with wet hands.

SAVE THESE INSTRUCTIONS

Warning Label Locations

START-UP INSTRUCTIONS

1. Attach garden hose.
2. Attach pressure hose.
3. Attach gun and lance.
4. Turn water supply ON.
5. Squeeze trigger to purge air from pump.
6. Insert nozzle.
7. Plug in power cord, reset the GFCI, start motor.

SHUT-DOWN INSTRUCTIONS

1. Turn motor OFF.
2. Unplug the power cord.
3. Turn water supply OFF.
4. Squeeze trigger to relieve system pressure.
5. Remove garden hose.
6. Remove pressure hose.



⚠ WARNING



- ◆ Gun kicks back. Hold with both hands.
- ◆ Risk of injection or injury to persons. Do not direct discharge stream at persons.
- ◆ Risk of fire and explosion. Do not spray flammable liquids.
- ◆ To reduce the risk of injury, read owner's manual carefully before using.

©2008 NT+E Co. 800-270-0810

Part No. 778069

FIG02833

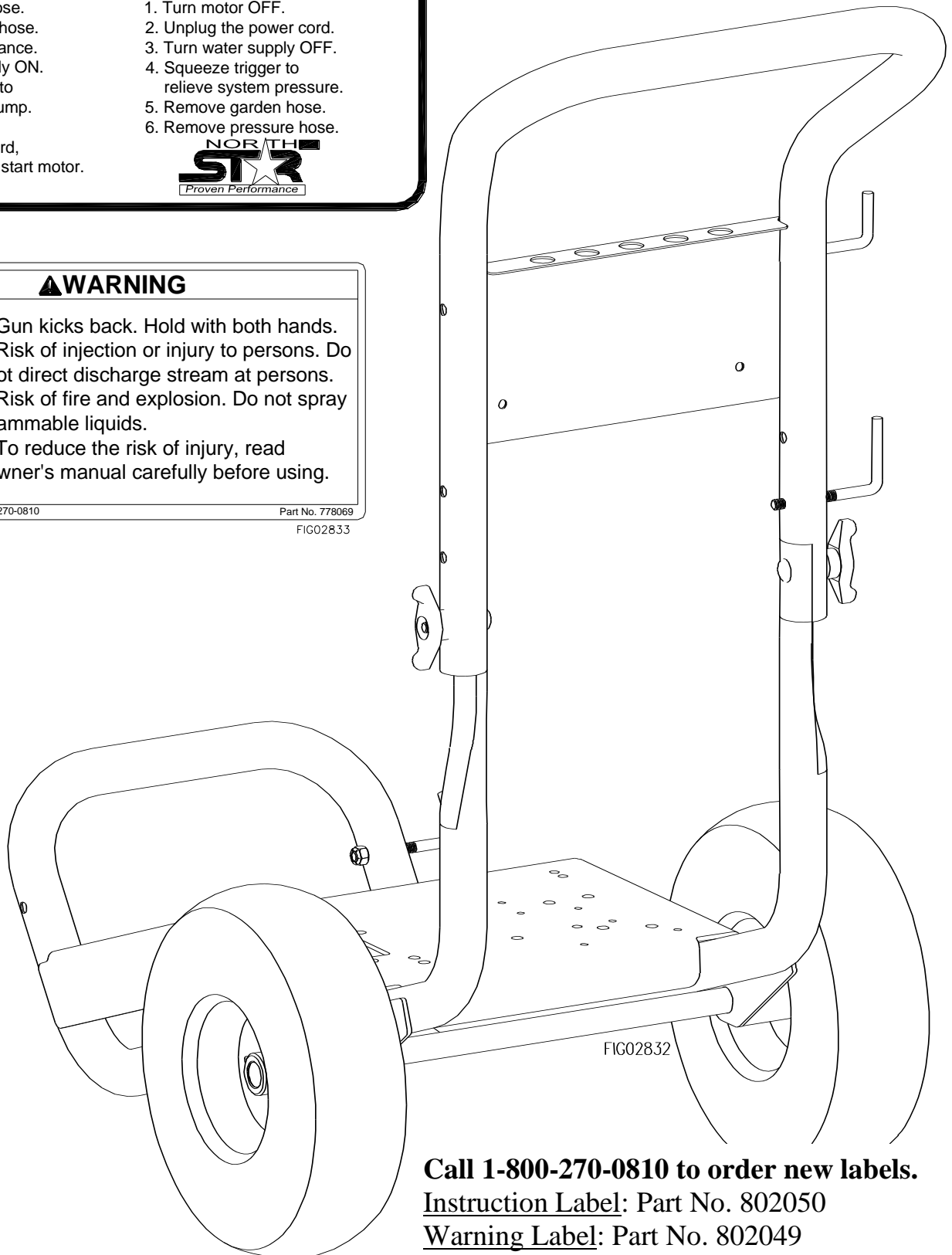

Call 1-800-270-0810 to order new labels.

Instruction Label: Part No. 802050

Warning Label: Part No. 802049

Assembly Instructions

I.) Unpack

Your pressure washer is shipped in one box. Separate and identify the components found in both boxes.

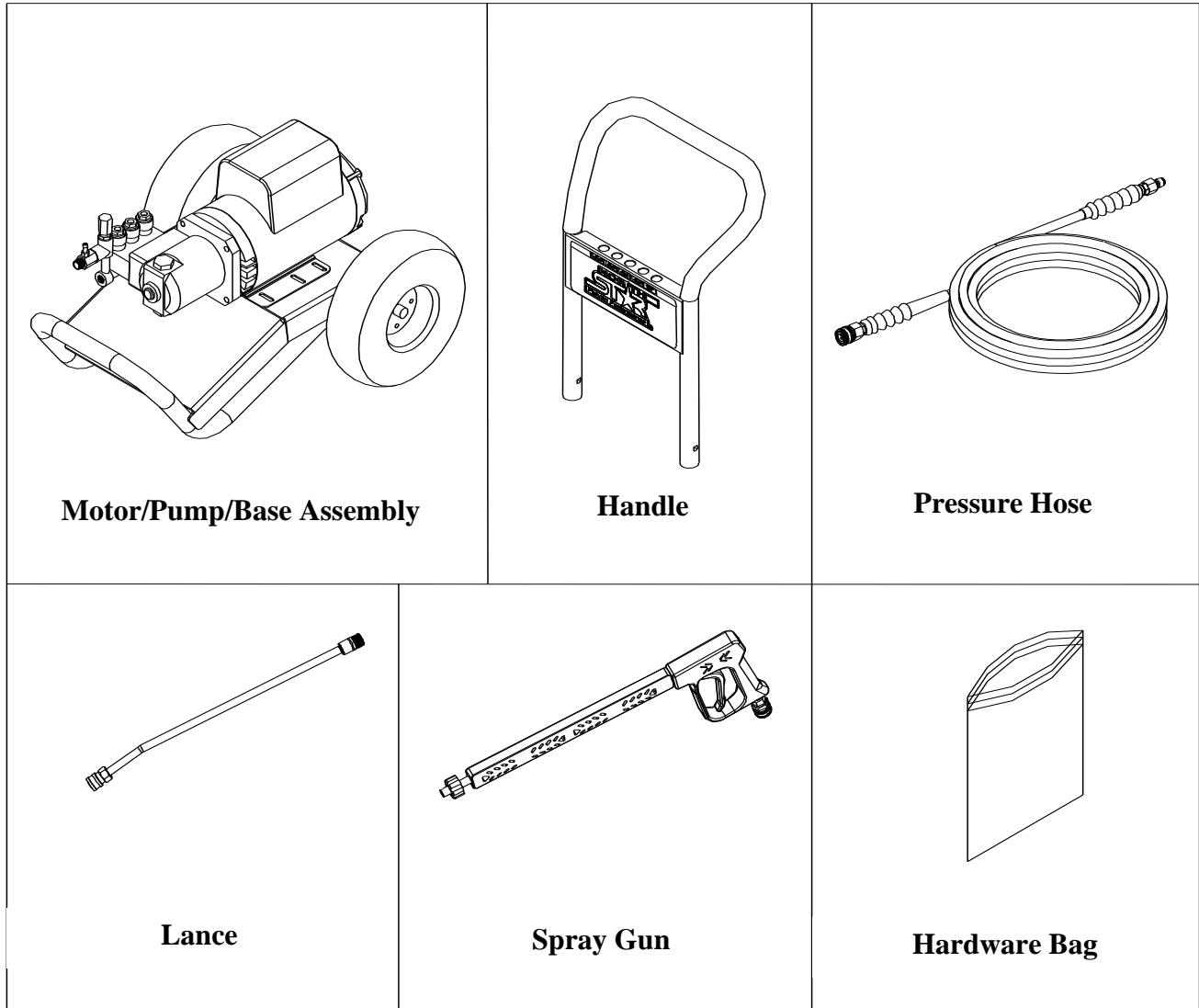
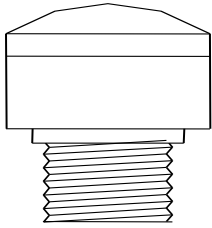

fig02299

* Figures shown are for representation only. Actual components will vary by model.

Assembly Instructions

I.) Hardware Bag



Vented fill cap
(1573001 only)

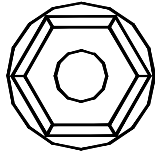

Flange Nut – Qty 2
Part # 82019

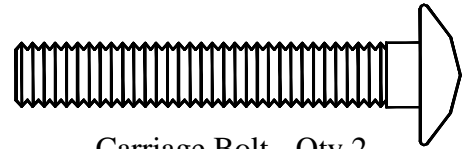

Carriage Bolt - Qty 2
Part # 82233

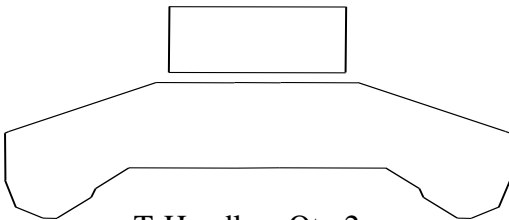

T-Handle – Qty 2
Part # 38578

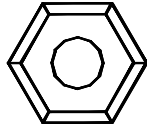

Nylock Nut – Qty 4
Part # 777495

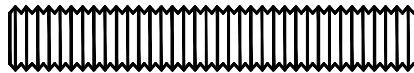

Gun Hook – Qty 1
Part # 38509

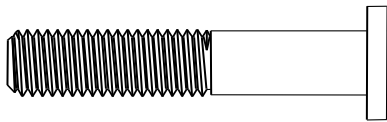

Hose Hook – Qty 2
Part # 779761

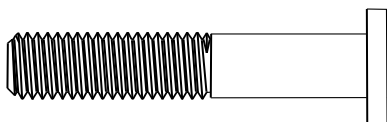
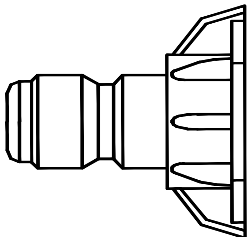
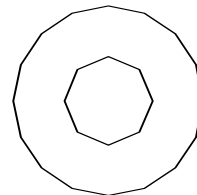

fig02301



Nozzle – Qty 2
Part # varies
by model



Grommet – Qty 5
Part # 35198

Assembly Instructions

III.) Handle Assembly

- 1.) Attach handle to base with two carriage bolts and t-handle knobs.
- 2.) Spin a flange nut backwards onto gun hook. (see hook detail)
- 3.) Mount the hose hooks onto the handle and gun hook onto the base as shown.
- 4.) Insert grommets into the holes on the handle nameplate.
- 5.) Press nozzles into grommets according to the colors indicated on the handle decal.

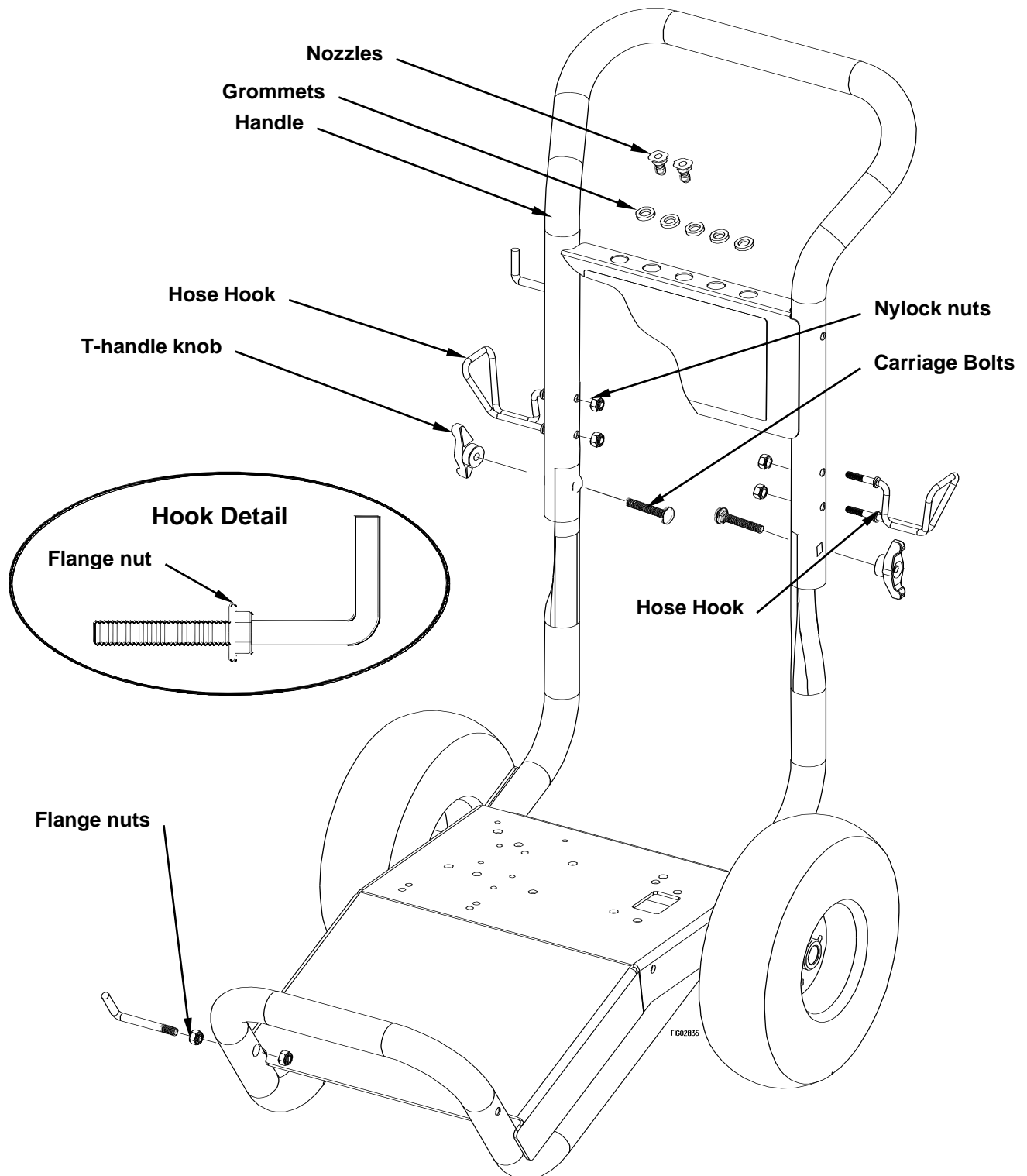

Machine Component Identification

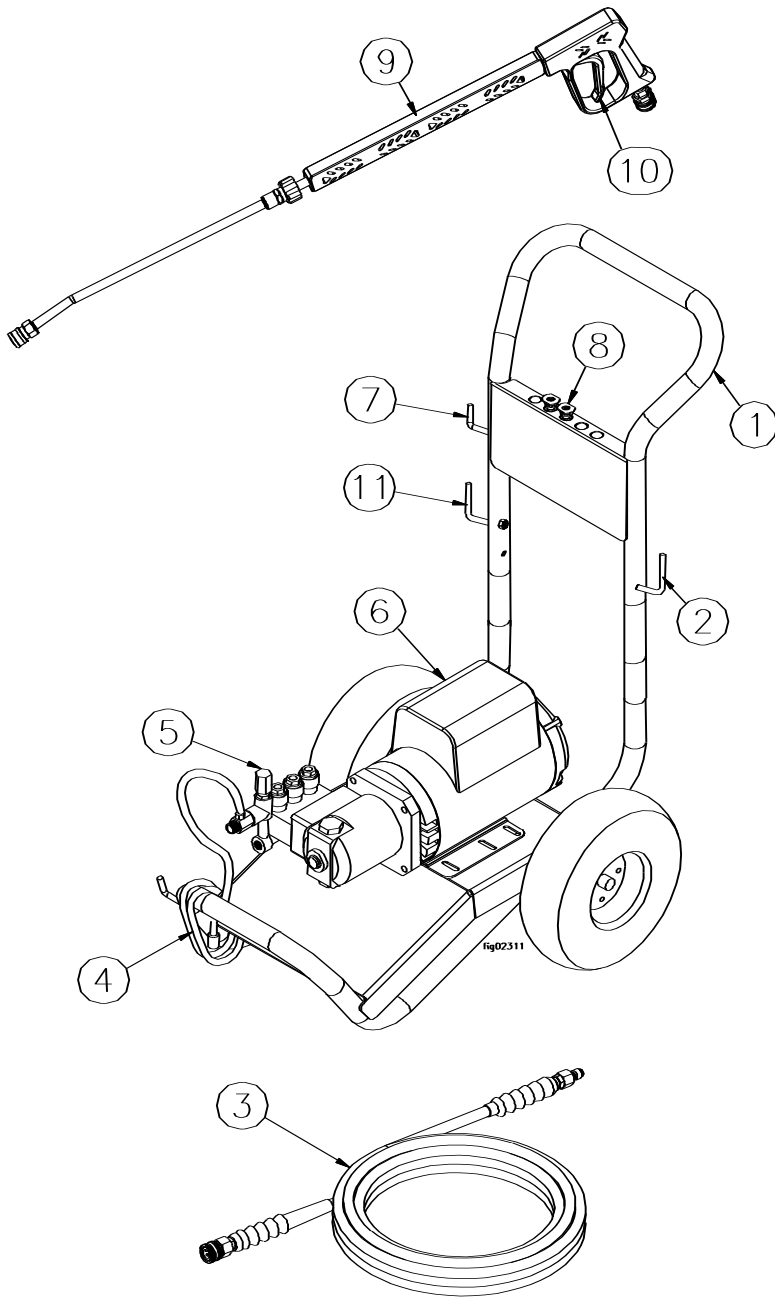

- 1.) **Handle.** Designed for easy cart movement.
- 2.) **Hose Hook.** Store hose on hook.
- 3.) **Pressure Hose.** Attach quick couplers to gun and water outlet.
- 4.) **Chemical Hose.** Submerge in cleaning solution.
- 5.) **Water Pump.** Inspect for loose/broken parts prior to each use.
- 6.) **Motor.** Leeson motor provides years of reliable use.
- 7.) **Gun Hook.** Store gun on hook.
- 8.) **Nozzles.**
- 9.) **Spray Gun.** Always use two hands for safe operation.
- 10.) **Trigger.** Actuate to allow pressurized water to flow out of spray gun.
- 11.) **Cord Hook.** Store electrical cord on hook.

* Components shown are for representation only. Actual components will vary by model.

Pump Component Identification

1573001

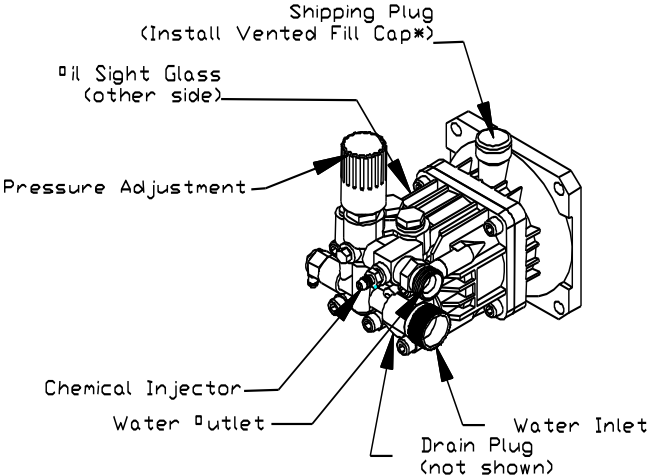

1573011 & 1573021

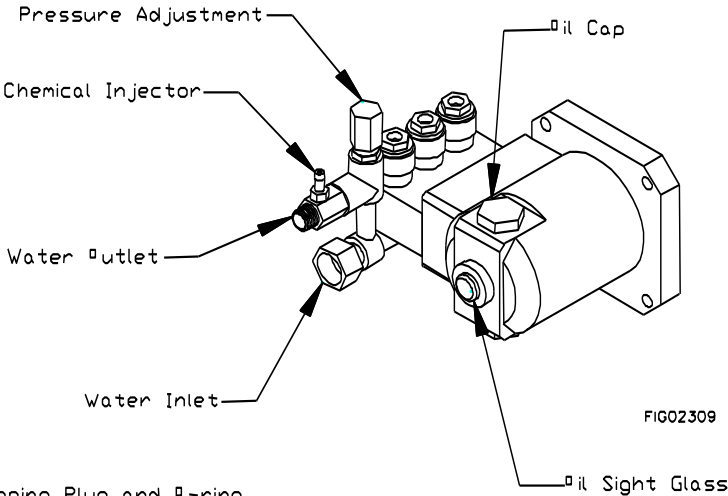

*Note: Discard Shipping Plug and O-ring

Operation Instructions

Water Supply

- 1.) Make sure the water supply is clean. Debris can cause excess pump wear and reduce performance.
- 2.) An insufficient water supply will damage your pump. Make sure the water supply is steady and is 20% over the rated flow of your pump. Use a stopwatch to time how long it takes to fill a 5-gallon bucket with your garden hose. The bucket must fill faster than the times listed in the table below.

Model	Time to fill a 5 gal. bucket
1573001	150 seconds
1573011	160 seconds
1573021	96 seconds

- 3.) The water supply garden hose must have an inside diameter of at least 5/8". If the hose is more than 100 ft. long, the diameter must be at least 3/4".
- 4.) Never use a reservoir tank as a water source. Drawing water out of a tank may cause pump cavitation and damage to your pump. This pressure washer is designed for a pressurized water source such as a city water faucet. However, the water source pressure must not exceed 115 psi (8 bar).

Always use a flexible rubber hose for your water supply. Do not use rigid piping.

START-UP INSTRUCTIONS

1. Attach garden hose.
2. Attach pressure hose.
3. Attach gun and lance.
4. Turn water supply ON.
5. Squeeze trigger to purge air from pump.
6. Insert nozzle.
7. Plug in power cord
8. Reset the GFCI button on the cord
9. Start motor.

SHUT-DOWN INSTRUCTIONS

1. Turn motor OFF.
2. Unplug the power cord.
3. Turn water supply OFF.
4. Squeeze trigger to relieve system pressure.
5. Remove garden hose.
6. Remove pressure hose.

WARNING

Skin puncture hazard.

High pressure fluid can inject under skin resulting in serious injury including amputation. Do not direct spray at people or animals.

- If skin injection happens, seek IMMEDIATE surgical treatment.
- Do not check for leaks with hand. Instead, use a piece of cardboard to check for leaks.
- Do not use unit if exterior hose damage is evident. Make sure all fittings are tight before starting. Relieve system pressure before servicing.
- Know how to stop engine and bleed pressures quickly. Be thoroughly familiar with the controls.
- Make sure accessories meet the unit's temperature and pressure limits.
- Stop engine and bleed pressures before leaving unit unattended.

fig01863

Operation Instructions

Spray Gun Safety Lock

When not spraying, use the spray gun safety lock to prevent accidental high-pressure discharge.

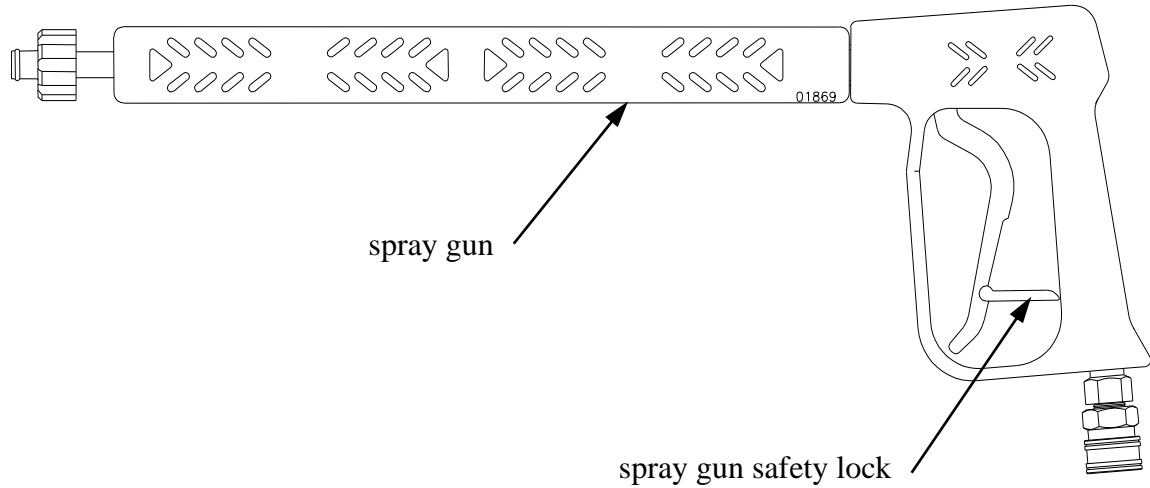

* Note: Depending on model, gun may appear differently.

Attaching the Lance

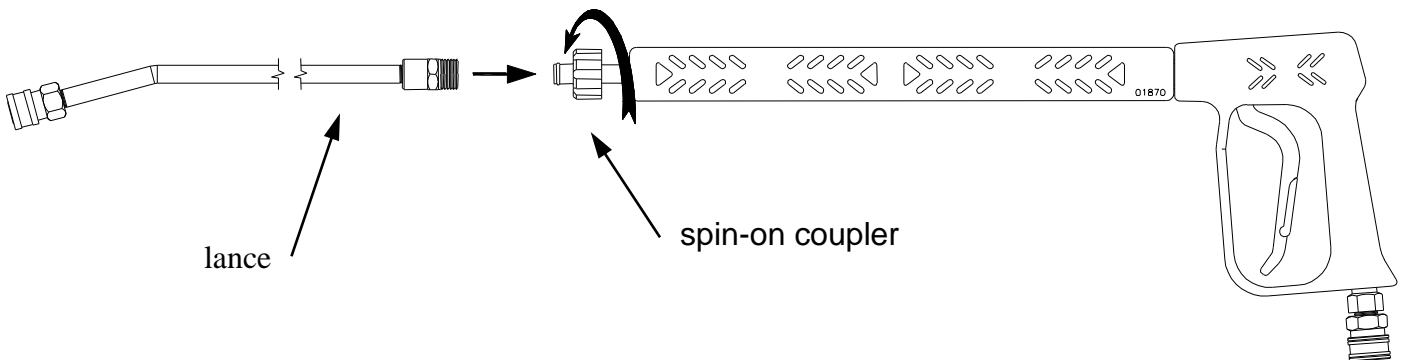

Tighten spin-on coupler hand tight.

Note: The o-rings make the seal so there is no need to tighten with a wrench.

Operation Instructions

Installing Nozzles

To install a nozzle pull back the collar and push the nozzle into the coupler. Once the connection is made, pull on the nozzle to make sure it is secure.

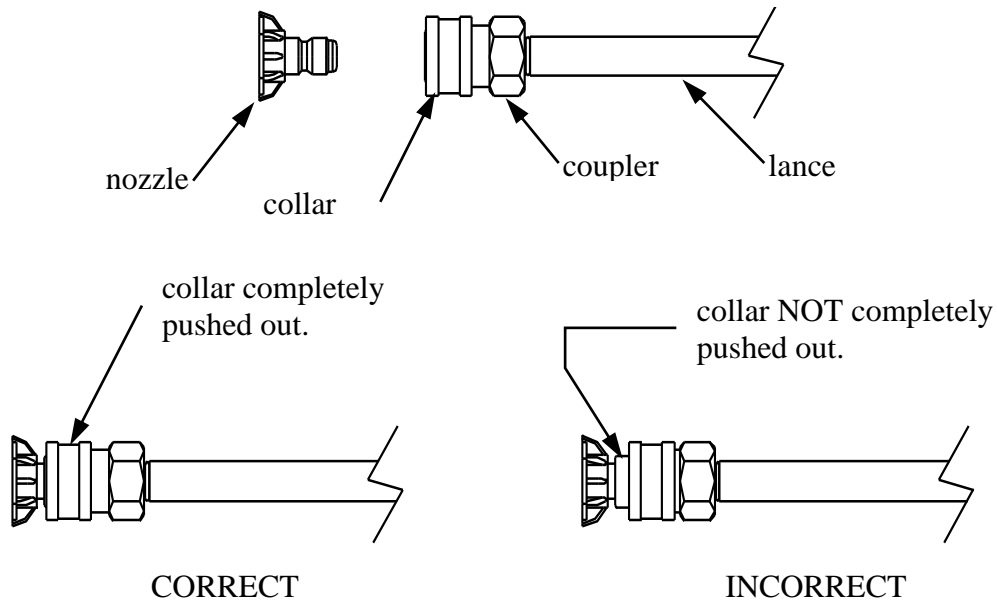

! WARNING

Flying objects.

Make sure nozzle is secure before squeezing trigger. If nozzle is not secure it will become a projectile. Serious injury can occur.

fig01864

Attach Quick Connect Couplers

- To install the hose onto the pump, pull back the collar and push the hose into the coupler on the pump.
- To install the hose onto the spray gun, pull back the collar on the spray gun and push the hose into the coupler on the spray gun.

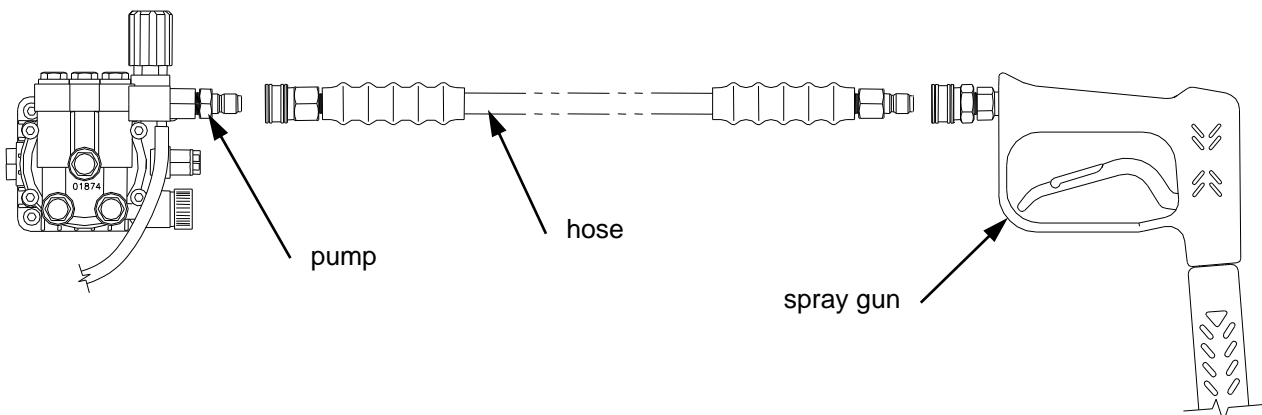

Once the connections are made, pull on the hose to make sure it is secure.

Operation Instructions

Applying Chemicals

- 1.) Install the black nozzle when applying chemicals onto the cleaning surface.
- 2.) Start the pressure washer according to the start-up instructions.
- 3.) Submerge the chemical hose in cleaning solution. (See Pump Component Identification section for chemical injector location.)
- 4.) Squeeze the spray gun trigger. The chemical injector will draw the chemical into the water stream.
- 5.) Apply chemicals evenly onto the cleaning surface. Allow the chemicals to react with the dirt, then clean at high pressure with high pressure (green or yellow) nozzle.
- 6.) Never use more chemical than is necessary to clean the surface.
- 7.) To clean the chemical injector, draw water through the strainer until all the chemical is purged from the system.

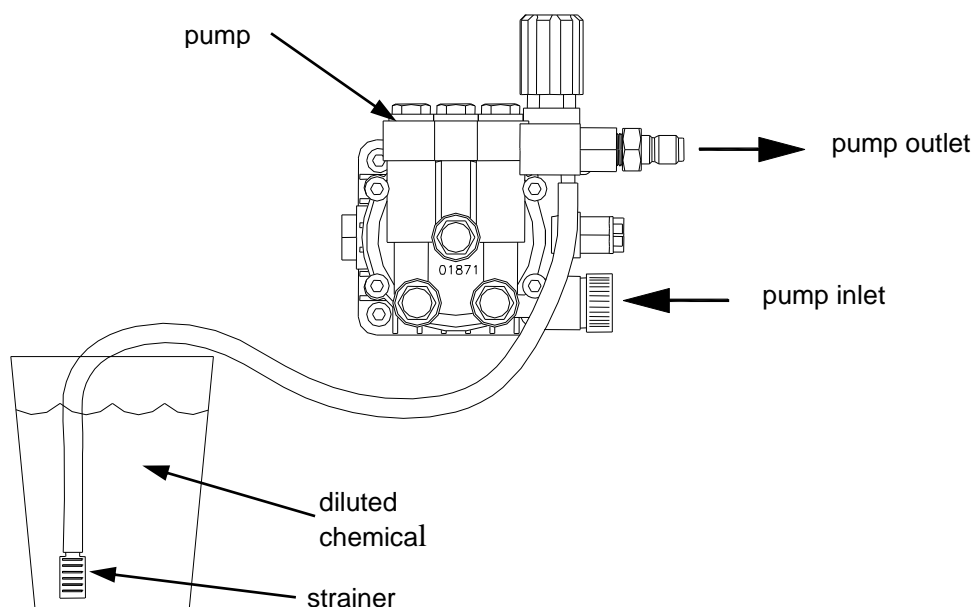

! WARNING

Risk of exposure to dangerous chemicals.

Serious injury or death can result if chemical manufacturer instructions are not followed.

- Wear protective gloves when handling and cleaning with chemicals.
- Understand all safety hazards and first aid for all chemicals being used.
- When cleaning filters, check if chemicals have been used and take any precautions that are recommended by the chemical manufacturer.
- Different chemicals may interact dangerously with each other, always follow chemical manufacturer directions before switching chemicals.
- Calculate the correct amount of chemical to mix, dispose of excess chemical per the manufacturer instructions.
- Never spray flammable liquids.



fig01846

Maintenance and Storage

Maintenance Mode

Read and follow these safety rules whenever you will be servicing the pressure washer:

- **Turn off / unplug / relieve pressure first.** Always turn off and unplug the pressure washer and relieve system pressure before inspection or maintenance.
- **Replace guards.** Make sure all guards and cover shields are replaced after servicing the pressure washer.
- **Major repair.** Major service, including the installation or replacement of parts, should be performed only by a qualified electrical service technician. Obtain factory-approved parts from NorthStar Product Support at 1-800-270-0810.
- **Replacement parts.** If a part needs replacement, only use factory approved repair parts. Replacement parts that do not meet specifications may result in a safety hazard or poor operation of the pressure washer and will void the warranty.

Maintenance Schedule

What to Check	When To Check	What to Do
Inlet Filter	Each Use	Visually inspect and clean inlet filter with clear water.
Pressure Hose	Each Use	Visually inspect pressure hose and hose couplings. Replace hose if any of the following is evident: hose coupling is damaged, wire mesh is exposed or damaged, hose is permanently kinked or flattened, outer hose cover is blistered or loose.
Bolts	Each Use	Tighten any loose bolts.
Pump Oil	After 1 st 50hrs, then 3mo/500hr	Change pump oil. See pump oil change instructions on next page.

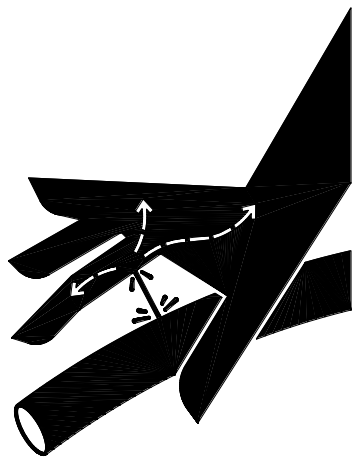

⚠ WARNING

Skin injection hazard.

High pressure fluid can inject under skin resulting in serious injury including amputation.

- Make sure all fittings are tight before applying pressure. Relieve system pressure before servicing.
- Do not check for leaks with hand. Instead, use a piece of cardboard to check for leaks.
- If skin injection happens, seek immediate "Surgical Treatment".

fig01454

Maintenance and Storage

Pump Oil Change

- 1.) Place a suitable container below the pump to catch the used oil, then remove the oil fill cap and oil drain plug.
- 2.) Allow the used oil to drain completely, then reinstall the drain plug and tighten securely.
- 3.) Please dispose of used oil in a manner that is compatible with the environment. We suggest you take used oil in a sealed container to your local recycling center or service station for reclamation. Do not throw it in the trash; pour it on the ground or down the drain.
- 4.) With the pump in a level position, fill to the halfway point on the oil sight glass (see pump oil capacities below). For Comet pumps use Universal Tractor Transmission Oil or Mobil 1 15W50 synthetic oil. For Cat pumps use SAE30 non-detergent oil or Cat Pump Oil Item# 22158.

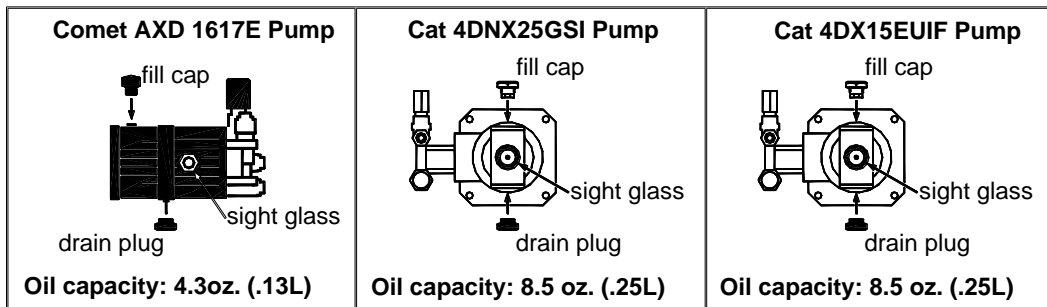

FIG05038

Maintenance and Storage

Winter Storage

Protect your pump, hose and gun from freezing.

Items needed: 12" piece of garden hose or equivalent, funnel and RV antifreeze (approximately 6 oz.)

- 1.) Follow the storage instructions listed above.
- 2.) Make sure the motor start switch is OFF.
- 3.) Attach the garden hose with funnel to the pump inlet (see illustration).
- 4.) Pour RV antifreeze into the funnel, run motor until antifreeze comes out the pump outlet.
- 5.) Drain all water from the high pressure hose. Depress trigger on gun and drain all water out of gun/lance.

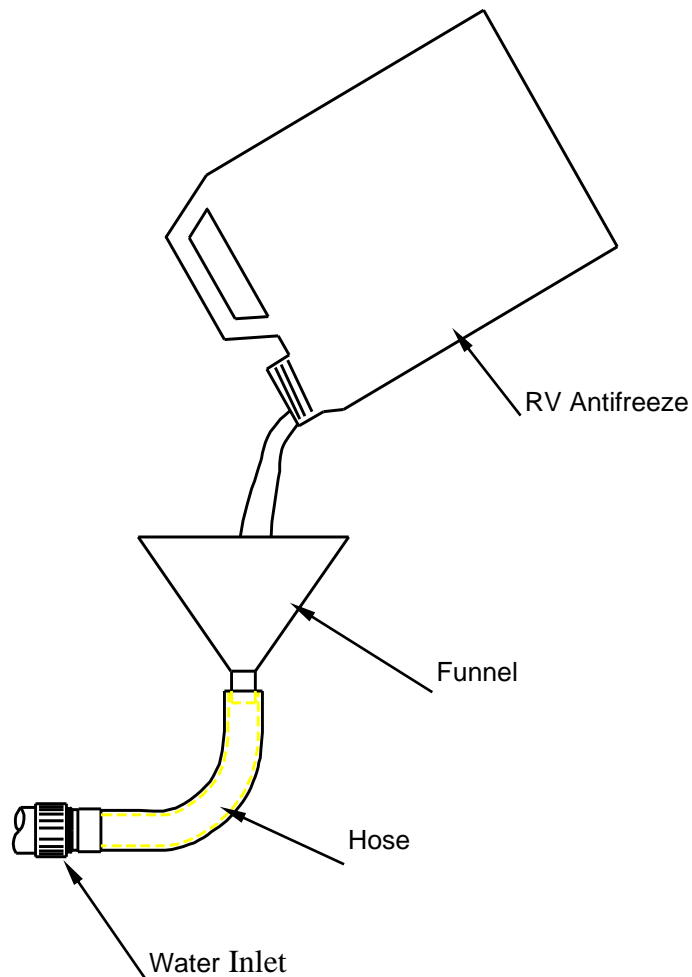

Troubleshooting

Problem	Solution
Motor will not start	SOLUTION: A,B
Low/Surging pressure or no water flow	SOLUTION: C,D,E,F,G,H
No chemical injection	SOLUTION: I,J,K,L
Cause	Solution
A- Tripped GFCI cord	Reset GFCI cord
B- Tripped motor relay	Reset motor
C- Insufficient water supply	See water supply section of this manual
D- Plugged pump inlet filter	See maintenance section of this manual
E- Wrong nozzle	Make sure high pressure nozzle is being used
F- Plugged nozzle	Remove nozzle, check for blockage
G- Worn nozzle	Replace nozzle
H- Leak in pressure hose	Replace pressure hose
I- Wrong nozzle	Make sure chemical nozzle is being used
J- Back pressure from extra-long discharge hose	Try shorter hose
K- Leak in chemical siphon hose	Replace hose – use hose clamps if necessary
L- Chemical strainer not submerged	Make sure strainer is completely submerged

The manufacturer reserves the right to make improvements in design and/or changes in specifications at any time without incurring any obligation to install them on units previously sold.

Any Questions, Comments, Problems or Parts Orders
Call NorthStar Product Support 1-800-270-0810

Specifications

1573001

PSI (bar)	1700 (117)
GPM (l/min)	1.5 (5.7)
Max Water Temp	140°F (60°C)
Dimensions L x W x H	34" x 21" x 38" (864mm x 534mm x 965mm)
Weight	95 lb. (44kg)

1573011

PSI (bar)	2000 (138)
GPM (l/min)	1.5 (5.7)
Max Water Temp	140°F (60°C)
Dimensions L x W x H	34" x 21" x 38" (864mm x 534mm x 965mm)
Weight	115 lb. (44kg)

1573021

PSI (bar)	3000 (207)
GPM (l/min)	2.5 (9.4)
Max Water Temp	140°F (60°C)
Dimensions L x W x H	34" x 21" x 38" (864mm x 534mm x 965mm)
Weight	139 lb. (55kg)

Wiring Diagram

1573001

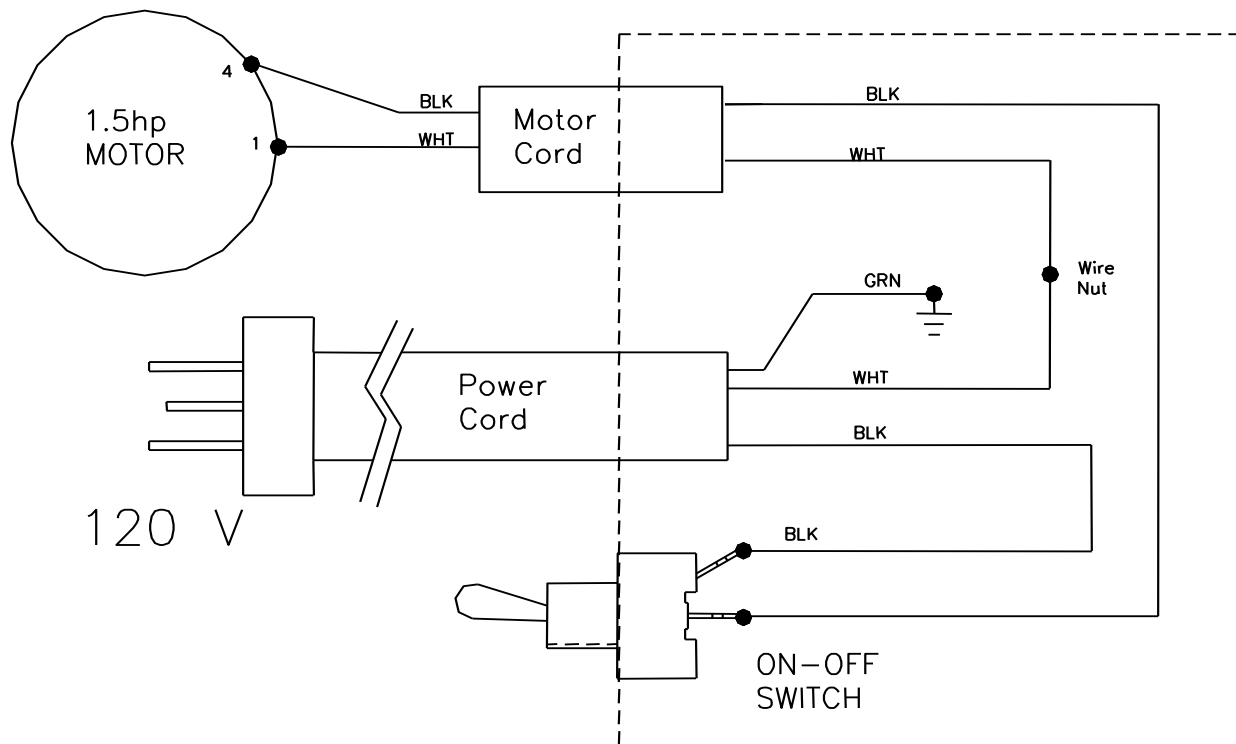

FIG02323

Wiring Diagram

1573011

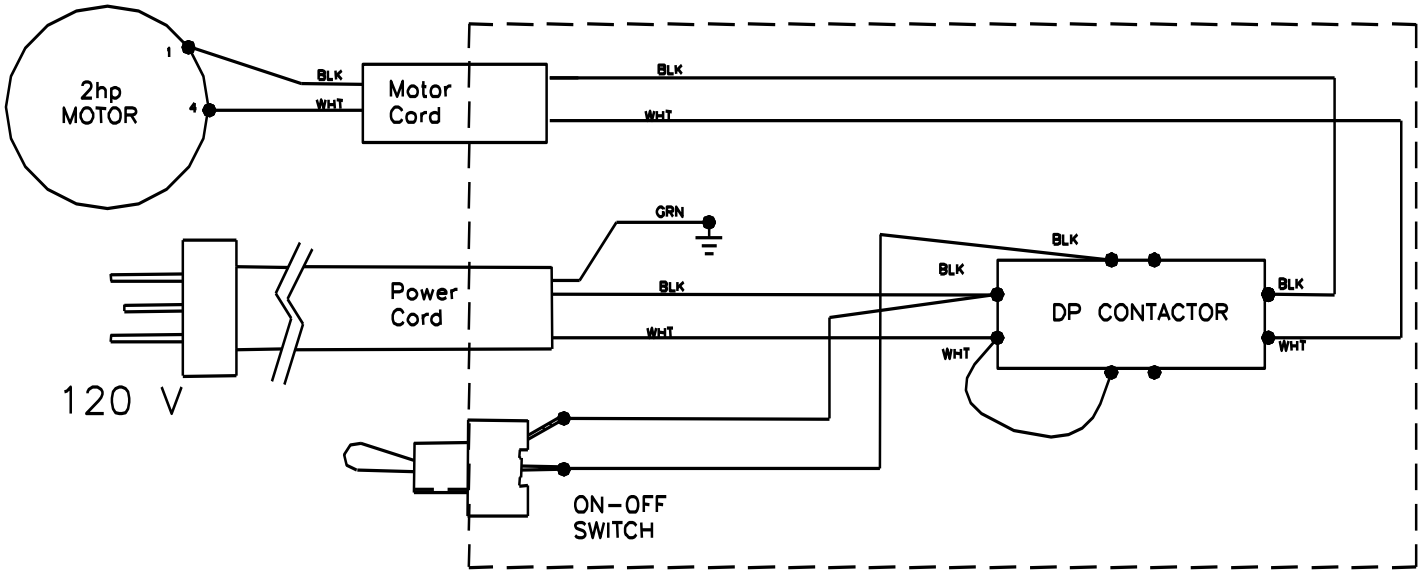

FIG02326

1573021

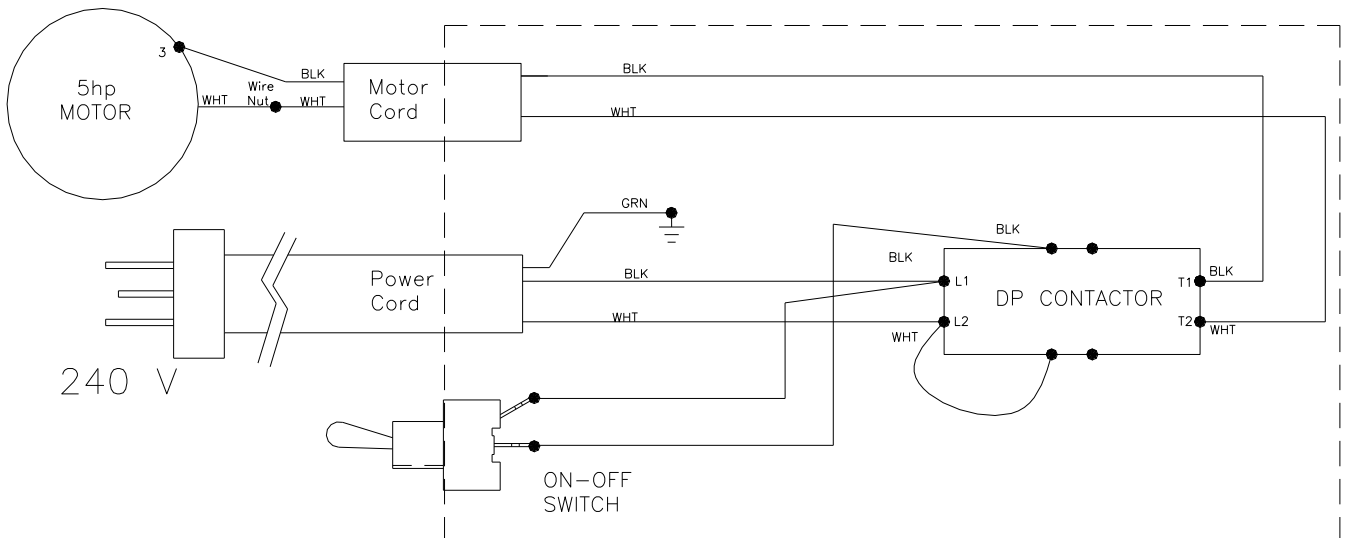

FIG02326

Parts Explosion M1573001 - Rev Y

ITEM #	PART #	DESCRIPTION	QTY	MODELS
1	38509	Threaded Gun Hook	1	All
2	802037	NorthStar Decal	1	All
3	35198	7/16 ID Grommet	5	All
4	802038	Handle	1	All
5	779761	Hose/Cord Hook	2	All
6	38578	T-Handle Knob	2	All
7	802039	Base	1	All
8	788813	Tire Wheel Assembly	2	All
9	305200	Wheel Retainer	2	All
10	38524	5/16 x 25' Gray Hose	1	1573011,1573021
11	777915	3/8" Quick Connect Nipple	1	1573011,1573021
12	777914	3/8" Quick Connect Coupler	1	1573011,1573021
13	221222	Chemical Strainer	1	All
14	777165	1/4" Braided Chemical Hose	3 ft.	All
15	778146	Motor Cord, 14-2 AWG SJTW	1	1573001
	778147	Motor Cord, 12-2 AWG SJTW	1	1573011
	802409	Motor Cord, 12-2 AWG SJTW	1	1573021
16	780841	1/4 x 25' Black Hose	1	1573001
17	791309	18.5" Lance	1	All
18	791308	1/4" Quick Connect	1	All
19	778150	Nozzle 2 pack #2.0	1	1573001,1573011
	38530	Nozzle 2 pack #3.0	1	1573021
20	2215	Bumpers	2	All
23	802040	Electric Control Box Cover	1	All
24	803214	GFCI Cord, 120V/15A WITH DECAL	1	1573001
	803215	GFCI Cord 120V/ 20A WITH DECAL	1	1573011
	803216	GFCI Cord, 240V/30A WITH DECAL	1	1573021
25	802301	Motor, 1.5 HP WEG	1	1573001
	803226	Motor, 2.0 HP WEG	1	1573011
	802303	Motor, 5.0 HP WEG	1	1573021
26	790693	Pump, Comet AXD 1617E GH	1	1573001
	792420	Pump, Cat 4DX	1	1573011
	789205	Pump, Cat 4DNX	1	1573021
29	777915	QC 3/8" Female Nipple	1	1573011,1573021
30	35918	Thermal Protector	1	1573011,1573021
31	800985	Filter, Inlet, 3/8" NPT X 3/4" FGH	1	1573011,1573021
35	777855	Toggle Switch	1	All
	5260	On-Off Plate	1	All
36	38527	Gun, Consumer, QC	1	1573011,1573021
37	313107	3/8" Male NPT Coupler	1	1573011,1573021
38	38526	Gun, 2700 PSI, 22mm	1	1573001
39	778070	Cord Warning	1	All
40	778151	DP Contactor 120V/25A	1	1573011
	778152	DP Contactor 230V/30A	1	1573021
41	777838	1/4" Hex plug counter sunk	1	1573011, 1573021

Pump Exploded Views

Part # 790693
Comet AXD 1617E GH

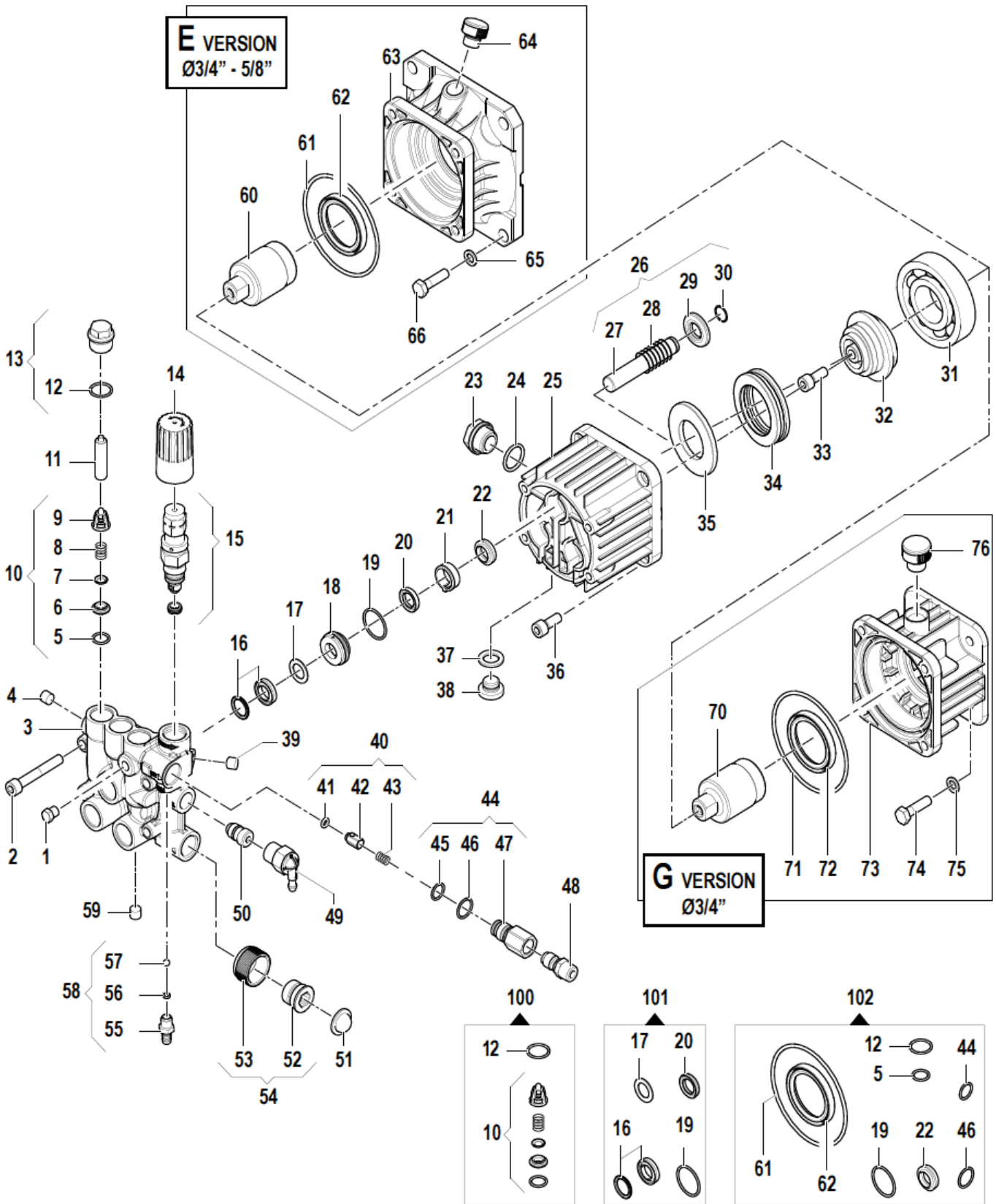

Pump Exploded Views

Part # 792420
Cat 4DX

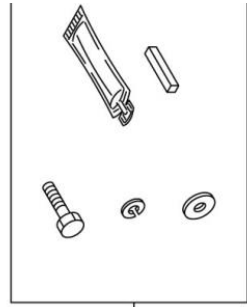

255

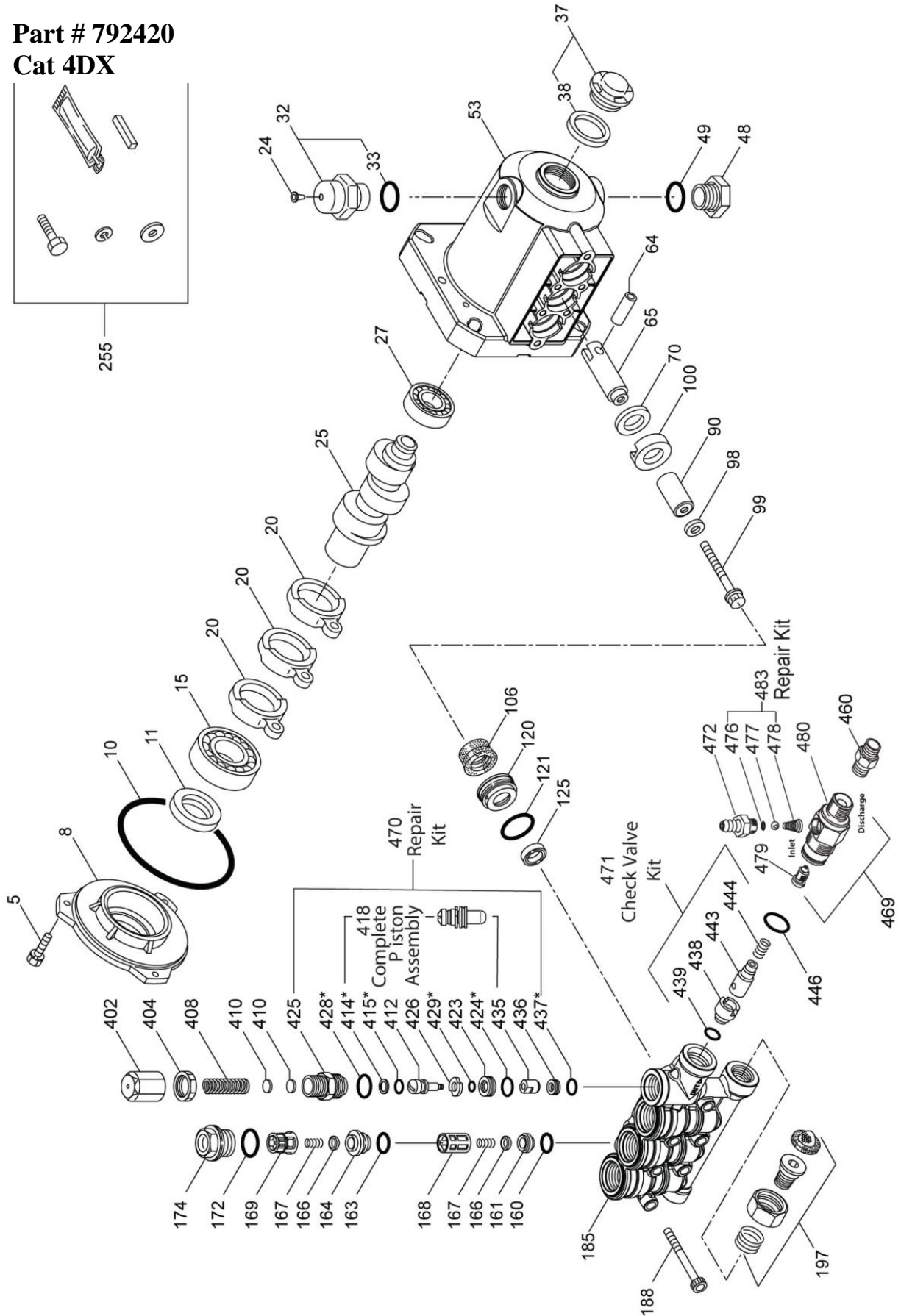

Pump Exploded Views

Ref#	P/N	DESCRIPTION	QTY
5	<i>Not Available</i>	Screw	3
8	CA547153	Bearing Cover	1
10	CA14041	O-Ring, Bearing Cover	1
11	CA55337	Oil Seal	1
15	CA14488	Inner Ball Bearing	1
20	CA547048	Connecting Rod	3
24	<i>Not Available</i>	Oil Plug Cap	1
25	<i>Not Available</i>	Crankshaft	1
27	CA15710	Ball Bearing	1
32	CA547961	Cap	1
33	CA14179	O-ring for Oil Filter Cap	1
37	CA92241	Gauge, Bubble Oil w/Gasket	1
38	CA44428	Gasket, Flat Flex Oil Gauge	1
48	CA44842	Drain Plug	1
49	CA14179	O-Ring for Drain Plug	1
53	<i>Not Available</i>	Crankcase	1
64	CA46229	Crosshead Pin	3
65	CA132190	Plunger Rod	3
70	CA47215	Oil Seal	3
90	CA542403	Plunger	3
98	CA46730	Washer	3
99	CA542405	Retainer, Plunger	3
100	CA46233	Retainer, Seal	3
106	CA48222	Seal	3
120	CA547357	Seal Case	3
121	CA13976	O-Ring for Seal Case	3
125	CA46240	Seal	3
160	CA13965	O-Ring, Inlet	3
161	CA545177	Seat, Inlet	3
163	CA19285	O-Ring	3
164	CA545178	Seat, Discharge	3
166	CA46764	Valve	6
167	CA46865	Spring	6
168	CA543988	Retainer, Spring, Inlet	3
169	CA49764	Retainer, Spring, Discharge	3
172	CA142807	O-Ring for Plug	3
174	CA547104	Plug, Valve w/o-ring	3
185	<i>Not Available</i>	Head, Manifold w/Unloader Body	1
188	<i>Not Available</i>	Screw	6

Ref#	P/N	DESCRIPTION	QTY
197	CA941516	Inlet Fitting Assembly	1
255	CA30516	Bolt Mount Assembly	1
401	CA32088	Handle Adjustable (Not Shown)	1
402	CA46570	Adjusting Cap	1
404	CA45070	Lock Nut	1
408	CA33394	Pressure Spring	1
410	CA549352	Spring Retainer	1
412	CA46251	Piston Stem	1
414	CA28338	Back Up Ring	1
415	CA22056	O-Ring, Piston Stem	1
418	<i>Not Available</i>	Piston Assy (Included in # 470)	1
423	CA46249	Retainer Valve	1
424	CA13966	O-Ring, Valve Retainer (Outer)	1
425	CA46248	Piston Retainer	1
426	CA46250	Washer	1
428	CA26133	O-Ring	1
429	CA17399	O-Ring, Valve Retainer	1
435	CA548193	Valve	1
436	CA46253	Seat	1
437	CA13963	O-Ring, Seat	1
438	CA46254	Seat, Check Valve	1
439	CA13963	O-Ring, Check Valve Seat	1
443	CA541060	Valve, Check	1
444	CA45924	Spring	1
446	CA26133	O-Ring	1
460	CA107681	Discharge Fitting	1
469	CA7231	Chemical Fixed Injector	1
470	CA76031	Unloader Repair Kit Incls: 418, 428, 436, 437	1
471	CA76146	Check Valve Kit Incls: 438, 439, 443, 444, 446	1
472	CA46630	Barb	1
476	<i>Not Available</i>	Barb O-Ring	1
477	<i>Not Available</i>	Ball	1
478	<i>Not Available</i>	Spring	1
479	<i>Not Available</i>	Orifice	1
480	<i>Not Available</i>	Body	1
483	CA76176	Repair Kit	1
Kit #1	CA33053	Seal Kit Incls: 98, 106, 121, 125	1
Kit #2	CA76978	Valve Kit Incls: 160, 161, 162, 163, 164, 166, 167, 168, 169, 172	1
*	CA76754	O-ring Kit Incls: 414, 415, 424, 428, 429, 437	1

Pump Exploded Views

Part # 789205
Cat 4DNX

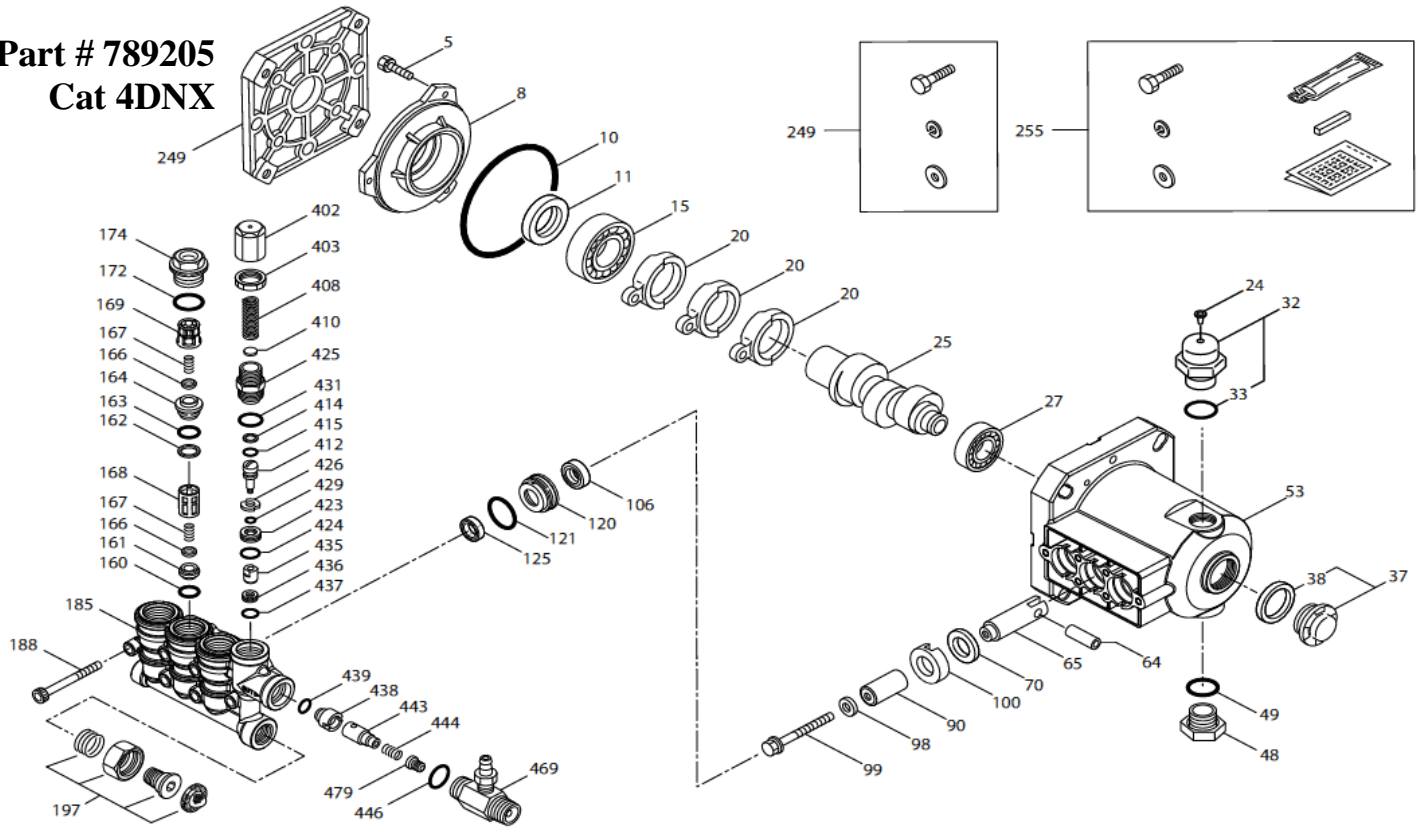

Ref#	P/N	DESCRIPTION	QTY
5	Not Available	Screw	3
8	CA547153	Bearing Cover	1
10	CA14041	O-Ring, Bearing Cover	1
11	CA55337	Oil Seal	1
15	CA14488	Inner Ball Bearing	1
20	CA547048	Connecting Rod	3
24	Not Available	Oil Plug Cap	1
25	CA549446	Crankshaft	1
27	CA56084	Ball Bearing	1
32	CA547961	Cap	1
33	CA14179	O-ring for Oil Filter Cap	1
37	CA92241	Gauge, Bubble Oil w/Gasket	1
38	CA44428	Gasket, Flat Flex Oil Gauge	1
48	CA44842	Drain Plug	1
49	CA14179	O-Ring for Drain Plug	1
53	Not Available	Crankcase	1
64	CA46229	Crosshead Pin	3
65	CA542402	Plunger Rod	3
70	CA47215	Oil Seal	3
90	CA547091	Plunger	3
98	CA46730	Washer	3
99	CA542405	Retainer, Plunger	3
100	CA46233	Retainer, Seal	3

Ref#	P/N	DESCRIPTION	QTY
106	Kit #1	Seal	3
120	Not Available	Seal Case	3
121	CA13976	O-Ring for Seal Case	3
125	Kit #1	Seal	3
160	CA17428	O-Ring, Inlet	3
161	CA547077	Seat, Inlet	3
162	CA48361	Back-up Ring	3
163	CA43358	O-Ring	3
164	CA547076	Seat, Discharge	3
166	CA547098	Valve	6
167	CA46865	Spring	6
168	CA543988	Retainer, Spring, Inlet	3
169	Kit #2	Retainer, Spring, Discharge	3
172	CA142807	O-Ring for Plug	3
174	CA547104	Plug, Valve w/o-ring	3
185	Not Available	Head, Manifold w/Unloader Body	1
188	Not Available	Screw	6
197	CA941516	Inlet Fitting Assembly	1
249	CA30520	Adapter Mount Assembly	1
255	CA30516	Bolt Mount Assembly	1
403	CA45070	Lock Nut	1
469	CA7332	Chemical Fixed Injector	1

KITS

Kit#1	CA76975	Seal Kit: Incls: 98, 106, 121, 125	1
Kit#2	CA76976	Valve Kit: Incls: 160, 161, 162, 163, 164, 166, 167, 168, 169, 172	1

One Kit will Complete One Pump

Limited Warranty

Dear Valued Customer:

The NorthStar Product you just purchased is built with the finest material and craftsmanship. Use this product properly and enjoy the benefits from its high performance. By purchasing a NorthStar product, you show a desire for quality and durability. Like all mechanical equipment this unit requires a due amount of care. Treat this unit like the high quality piece of machinery it is. Neglect and improper handling may impair its performance. Please thoroughly read the instructions and understand the operation before using your product.

Limited Warranty

NorthStar shall warranty any piece of equipment manufactured, or parts of equipment manufactured, to be free from defects in material or workmanship for a period of:

Item #	Warranty Period
1573001	1 year from date of purchase by user
1573011, 1573021	2 years from date of purchase by user

NorthStar shall warranty any wear item, including, but not limited to, valves, seals, pump diaphragms, hoses, and filter elements to be free from defects in material or workmanship for a period of 90 days from the date of purchase by user. This warranty applies to the original purchaser of the equipment and is non transferable. Verification of purchase is the responsibility of the buyer. Parts will be replaced or repaired at no charge, except when the equipment has failed due to lack of proper maintenance. Any misuse, abuse, alteration or improper installation or operations will void warranty. Determining whether a part is to be replaced or repaired is the sole decision of NorthStar.

NOTE: Some services performed by parties other than NorthStar may void warranty.

This warranty covers parts only. It will not provide for replacement of complete products due to defective parts. Components not manufactured by NorthStar are guaranteed by their manufacturer and can be serviced at factory-authorized locations near you. Any costs incurred due to replacement or repair of items outside of a NorthStar approved facility is the responsibility of the buyer and not covered under warranty. NorthStar can supply you with the service center location in your area.

This warranty specifically excludes the following; failure of parts due to damage caused by accident, fire, flood, windstorm, acts of God, applications not approved by NorthStar in writing, corrosion caused by chemicals, use of replacement parts which do not conform to manufacturer's specifications, and damage caused by vandalism. Additional exclusions: loss of running time, inconvenience, loss of income, or loss of use, including any implied warranty of merchantability of fitness for a specific use.

Warranty does not cover items subject to normal wear such as tires, receptacles or any part subject to direct physical contact by the public. This warranty does not cover any personal injury or damage to surrounding property caused by failure of any part.

This warranty is in lieu of any other warranty expressed or implied and NorthStar assumes no other responsibility or liability outside that expressed within this warranty.

Please fill in the following information and have it on hand when you call in on a warranty claim.

Customer Number: _____

Date of Purchase: _____

NorthStar Serial Number: _____

Item Number: _____

⚠ WARNING: This product can expose you to soots, tars, and mineral oils (untreated and mildly treated oils and used engine oils), which are known to the State of California to cause cancer.

For more information go to www.P65Warnings.ca.gov.



Manufactured by
Northern Tool + Equipment Co.,
2800 SouthCross Drive West
P.O. Box 1499 Burnsville, MN 55337-0499