



M157115N

ITEM NUMBER: 157115/1571151

SERIAL NUMBER: _____

Owner's Manual

Instructions for Set-up, Operation, Maintenance & Storage

HOT WATER/STEAM PRESSURE WASHER – 3000 PSI / 4.0 GPM Portable Outdoor-Use Only

This pressure washer produces both cold and hot water high-pressure spray as well as wet steam. Cleaning chemicals may be incorporated into the spray if desired. The pressure pump for this equipment is powered by a gasoline internal combustion engine and the water is heated by a diesel, kerosene/fuel-oil fired, down draft burner.

⚠ WARNING – READ THIS MANUAL

READ and UNDERSTAND this Owner's Manual and the Engine Owner's Manual completely before attempting to set up and use the pressure washer! Failure to properly set up, operate, and maintain this pressure washer could result in *serious injury or death* to operator or bystanders.

⚠ WARNING – SPECIAL HAZARDS

CO Poisoning	<ul style="list-style-type: none"> Exhaust from both the engine and burner contains carbon monoxide, a poisonous gas that can cause carbon monoxide poisoning and possible death if inhaled. ONLY run pressure washer OUTDOORS and at least 20 feet from the home, away from windows, vents and air intakes, to allow proper ventilation. If you start to feel sick, dizzy, or weak while using the pressure washer, shut off the engine and get to fresh air RIGHT AWAY.
Skin/Eye Injury	<ul style="list-style-type: none"> High-pressure spray can cause serious skin or eye injury, including injection injury if fluid pierces the skin. Injection injury can result in blood poisoning and/or severe tissue damage.
Burns	<ul style="list-style-type: none"> Hot spray can scald and burn skin. Hot surfaces of wand, engine and burner, as well as hot exhaust from both the engine and burner can cause burns.
Slips/Falls	<ul style="list-style-type: none"> Spray discharge can cause puddles and slippery surfaces. Spray-gun kickback can cause operator loss of balance and falls.
Flying Debris	<ul style="list-style-type: none"> High-pressure spray can cause surface damage and flying debris.
Fire/Explosion	<ul style="list-style-type: none"> Engine and burner sparking can ignite fuel or other flammable liquids or vapors in the vicinity. Hot exhaust from engine and burner can ignite combustible materials.
Chemical Exposure	<ul style="list-style-type: none"> Cleaning chemical vapors or contact with skin may be hazardous.
Electric shock	<ul style="list-style-type: none"> Spray contact with electrical sources can cause electric shock.

A summary of important safety information is provided at the end of the manual.

Any Questions, Comments, Problems, or Parts Orders
Call NorthStar Product Support 1-800-270-0810

Hazard Signal Word Definitions





	This is the safety alert symbol. It is used to alert you to potential personal injury hazards. Obey all safety messages that follow this symbol to avoid possible injury or death.
	DANGER indicates an imminently hazardous situation which, if not avoided, will result in death or serious injury.
	WARNING indicates a hazardous situation which, if not avoided, could result in death or serious injury.
	CAUTION, used with safety alert symbol, indicates a hazardous situation which, if not avoided, may result in minor or moderate injury.
	CAUTION, without the safety alert symbol, is used to address practices not related to personal injury.

FIG03210

Equipment Protection Quick Facts

Inspect Upon Delivery	STOP! Closely inspect to make sure no components are missing or damaged. See the “Assembly and Initial Set-Up” section for instructions on whom to contact to report missing or damaged parts.	
Fill with Engine Oil	STOP! Engine is shipped <u>without</u> oil. DO NOT start pressure washer without adding oil to engine. Please refer to Engine Manual shipped with unit for acceptable grade motor oils. Refer to the Prepare Engine instructions in Step 3. Initial Pump & Engine Preparation of the Assembly and Initial Set-up section for additional oil quantity needed due to oil drain hose.	
Check Pump Oil	Pump is shipped with oil. Check pump oil level before starting. Remove shipping tape and black vent plug (if present) from oil fill cap.	
Water Flow Requirements	Make sure your supply water flow rate is 20% higher than the pressure washer’s flow rate (see “Specifications” section for detail), and that your water is clean and particle free.	
Storage	<u>Do not allow water to freeze in the pump, hose, coil, or spray gun(s).</u>	
Chemical Spraying	Use only NorthStar brand or equivalent washer chemicals designed for pressure washer use.	
Maintenance Schedule	Engine:	<ul style="list-style-type: none"> • See Engine Owner’s manual.
	Pump:	<ul style="list-style-type: none"> • Change oil after first 40 hours, then every 3 months or 500 hours.
	Burner fuel filter /water separator:	<ul style="list-style-type: none"> • Drain water as needed. • Change filter after every 500 hours of use
	Coil:	<ul style="list-style-type: none"> • Descale coil annually or more frequently as conditions / performance require. • Inspect coil for soot build-up annually and desoot if needed.
	Electrodes:	<ul style="list-style-type: none"> • Inspect electrodes annually and clean/adjust as needed.

Table of Contents

About Your Pressure Washer	4
Specifications	5
Component Identification	6
Safety Labeling	8
Special Equipment Safety Features	9
Assembly and Initial Set-Up	10
Step 1. Unpacking & Delivery Inspection	10
Step 2. Assembly	12
Step 3. Initial Pump & Engine Preparation.....	13
Moving and Handling	14
Before Each Use	15
Step 1. Check Equipment.....	15
Step 2. Add Fuel(s)	16
Step 3. Select a Suitable Worksite	18
Operation	20
Step 1. Connect Hose(s), Water Supply, and Spray Nozzle(s).....	20
Step 2. Set Up for Chemical Spray (if desired).....	23
Step 3. Spraying.....	24
Step 4. Stopping.....	30
Storage	31
Burner Adjustment	35
Maintenance and Repair	36
Troubleshooting	51
Major Components	53
Parts Explosion: Frame – Rev N	54
Parts Explosion: Heat Exchanger – Rev N	57
Parts Explosion: Blower & EMF – Rev N	59
Parts Explosion: Engine, Water & Fuel Pumps, Drive Parts – Rev N	61
Parts Explosion: Accessories- Gun, Hose, Chemical Injector – Rev N	63
Pump Explosion-CAT 66DX – Rev N	65
Wiring Diagram – Rev N	67
Summary of Important Safety Information	68
Limited Warranty	73
California Proposition 65 Information	76

About Your Pressure Washer

Thank you for purchasing a NorthStar hot water pressure washer! Your machine is designed for long life, dependability, and the top performance you demand. This pressure washer is designed to:

- 1) Produce a high-pressure wet steam spray or water spray (heated or unheated) -- up to 4.0 gallons per minute at 3000 psi.
- 2) Incorporate cleaning chemicals into a low-pressure water spray.

Wet steam is a combination of liquid water droplets and water vapor. Wet steam delivers more heat, and a balanced amount of flow and impact which increase cleaning effectiveness and reduce spray back.

The pump requires a clean, standard tap water supply provided through a garden hose at a flow rate of at least 4.8 gallons per minute. The use of a backflow preventer on the water supply hose is recommended and may be required by local code. Any cleaning chemicals that are used must be specifically approved for use in pressure washers.

The pump is powered by a gasoline-fueled engine. The spray water is heated (when desired) by a diesel, kerosene/fuel-oil fired, spark-ignited, down draft burner. Normal operation of this equipment will require you to supply:

- Gasoline fuel and lubrication oil for the engine
- Pump oil
- Fuel for the burner (diesel, kerosene, or fuel oil)

See the “**Specifications**” section of this manual for more detail.

Gasoline powered pressure washers are for OUTDOOR USE ONLY. Be sure to read about site selection for running this pressure washer in the “**Before Each Use**” section of this manual.

The user should plan to acquire and wear safety apparel during operation of this pressure washer. Safety apparel includes waterproof insulated gloves, safety glasses with side and top protection, and non-slip protective footwear. Some cleaning chemicals may require the use of a respirator mask (as instructed on chemical label).

Before using this washer, the user shall determine the suitability of this product for its intended use and assumes liability therein.

Read this Manual

WARNING

Carefully read and follow all instructions and safety information for using this pressure washer. Improper use or maintenance of the pressure washer can result in **serious injury or death** to the operator or bystanders from:

- *Carbon monoxide poisoning*
- *Fire/explosion*
- *Chemical exposure*
- *Skin/eye injury from high pressure spray*
- *Burns*
- *Slips/falls*
- *Electric shock*
- *Flying objects/debris*

Keep this manual for reference and review. A summary of important safety information can be found at the end of the manual.

Proper preparation, operation, and maintenance of this pressure washer will result in optimal performance and a long life for this equipment. For detailed Engine operation and maintenance information, always refer to the Engine Owner’s Manual furnished with the pressure washer.

ATTENTION:

Rental Companies and Private Owners who loan this equipment to others!

All persons to whom you rent/loan this pressure washer must have access to and read this manual. Always keep this owner’s manual with the pressure washer and advise all persons who will operate the machine to read it. You must also provide personal instruction on how to safely set-up and operate the pressure washer and remain available to answer any questions a renter/borrower might have.

Specifications

MODEL	
Model #	157115/1571151
FLOW OUTPUT	
Pressure Rating	3000 psi
Flow Rate	4.0 gpm
Maximum Temperature	250° F
DIMENSIONS / COMPONENTS	
Length	46"
Width	32"
Height	43"
Weight (fueled)	457 lbs.
Pump Type	CAT 66DX
High Pressure Discharge Hose	3/8" x 50'
Chemical Injection Ratio	13 to 1
SUPPLIES REQUIRED (not included)	
Engine Fuel	Regular, Unleaded Gasoline
Engine Oil	See Engine Owner's Manual and Step 3 of the Assembly and Initial Set-up section for additional oil quantity needed due to oil drain hose.
Burner Fuel	#1 or #2 Diesel, B5 or lower Biodiesel, Kerosene, or Fuel Oil (Capacity: 5 Gal.)
Pump Oil (shipped with oil, but refills required)	SAE 30 non-detergent oil
Input Water Supply	Standard tap water @ 20-75 psi, delivered @ 4.8 gpm or higher
Input Water Supply Hose	Standard garden hose with inside diameter at least 5/8" (at least 3/4" diameter if hose longer than 100 ft.)

Component Identification

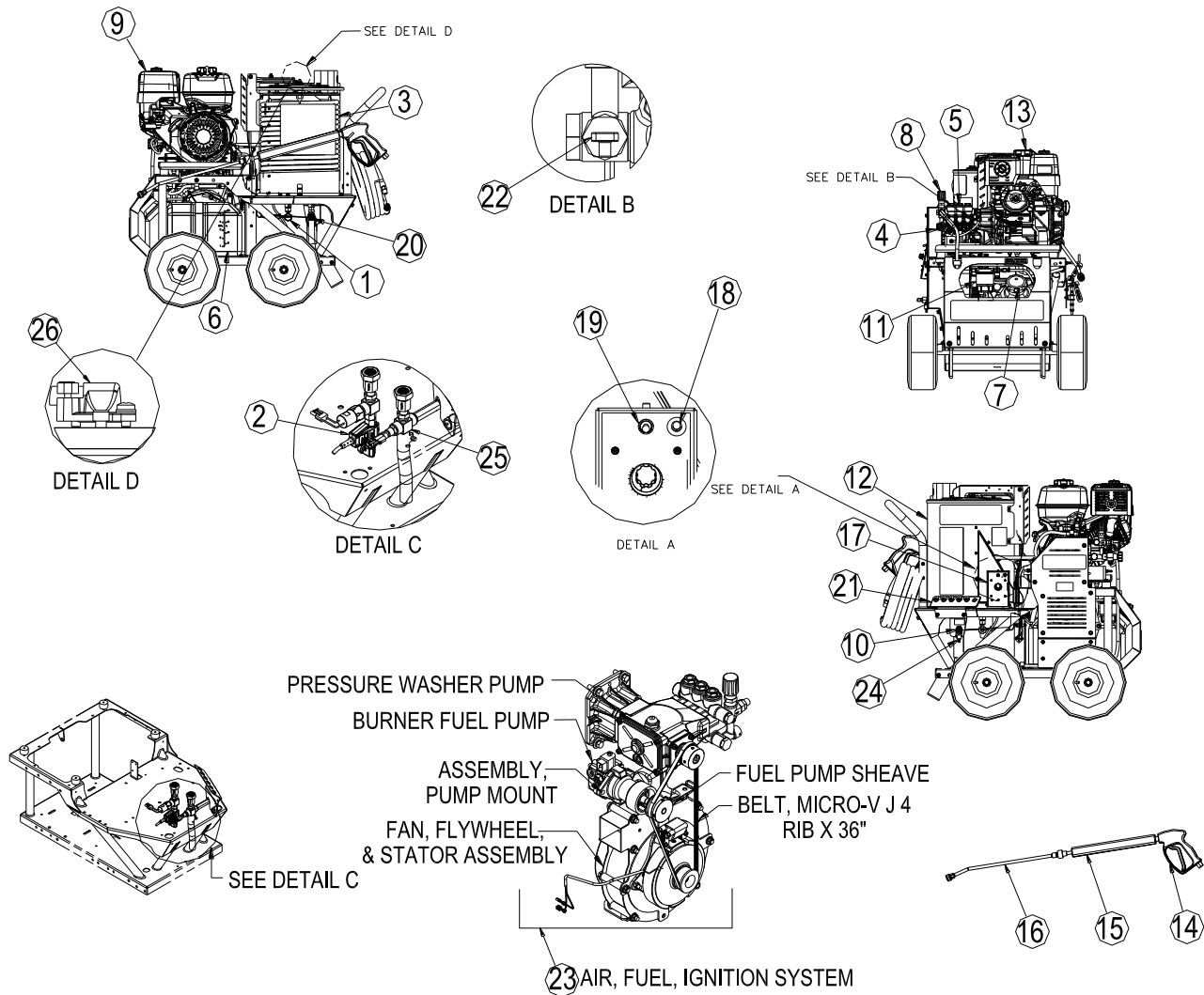

Fig157115_1L

Ref #	Description	Ref #	Description	Ref #	Description
1	High PSI limit switch	10	High Pressure Outlet	19	Heat Switch
2	Flow Switch	11	Fuel Filter/Water Separator	20	High-Temp. Limit Switch
3	Heating Coil	12	Heat Exchanger	21	Nozzle Storage
4	Garden Hose Water Inlet	13	Gas Tank & Cap	22	Thermal Relief Valve
5	Pump	14	Spray Gun	23	Air, Fuel, Ignition System
6	Diesel Fuel Tank	15	Grip	24	Chemical injector
7	Diesel Fuel Cap	16	Wand	25	Rupture Disc Fitting
8	Unloader	17	Control Box (See Detail A)	26	Flame Sensor
9	Engine	18	Circuit Protector		

Component Identification cont'd

REFERENCE GUIDE	
1. High, PSI limit switch	This is a backup safety feature, if the system pressure exceeds the set pressure this device will stop the burner from firing.
2. Flow Switch	Mechanical device that senses water flow
3. Heating Coil	Steel piping wound together with an inlet for incoming cold water and outlet for hot water to exit.
4. Garden Hose Water Inlet	Means of connecting garden hose to pump inlet. Connect garden hose here.
5. Pump	A device that moves fluid through a combination of suction and displacement.
6. Diesel Fuel Tank	Fuel storage container for diesel fuels.
7. Diesel Fuel Cap	Vented cover for fuel tank.
8. Unloader	Valve that regulates pressure and directs flow into bypass when trigger is closed.
9. Engine	The air-cooled engine powers the pump.
10. High Pressure Outlet	Connection point for the high-pressure hose.
11. Fuel Filter / Water Separator	Filter in fuel line that removes water and screens out dirt and debris from fuel.
12. Heat Exchanger	Device that heats the water by forcing a flame across steel pipe.
13. Gas Tank & Cap	Gas tank is a container for holding gas and gas cap is cover for gas tank.
14. Spray Gun	Used to divert water out to nozzle.
15. Grip	Section of wand to extend length and provide stability.
16. Wand	Rod to extend length.
17. Control Box	Housing device for mounting switches and machine controls.
18. Circuit Breaker	Device for protecting circuit from damage if overloaded or shorted.
19. Heat Switch	Acts as an on/off device for power to burner components.
20. High-Temp Limit Switch	Control Device that limits the water temperature.
21. Nozzle Storage	A space for storing nozzles.
22. Thermal Relief Valve	Safety device that discharges hot water from the pump manifold during long bypass operation.
23. Air, Fuel, Ignition System	System provides air, fuel, and ignition for combustion
24. Chemical Injector	Siphons cleaning chemicals into a low pressure washer spray downstream of the pump.
25. Rupture Disc	Safety device that will open and relieve excess system pressure
26. Flame Sensor	Device for sensing if the burner has a flame

Safety Labeling

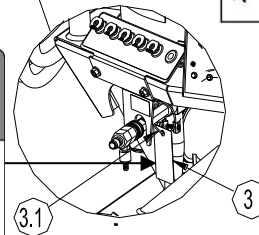
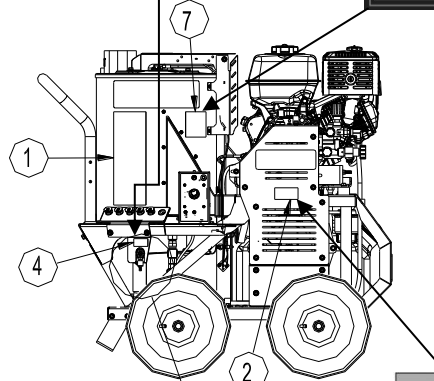
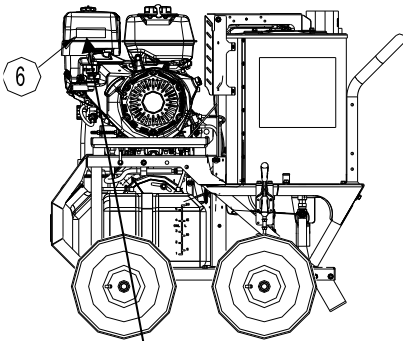
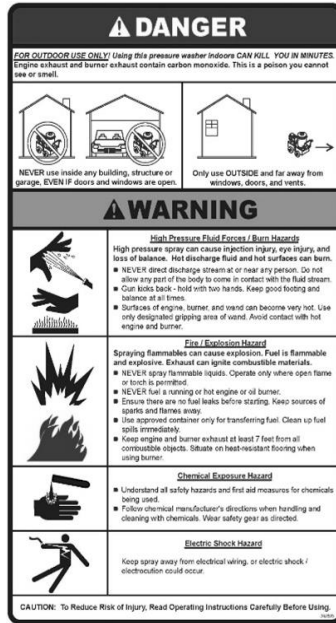
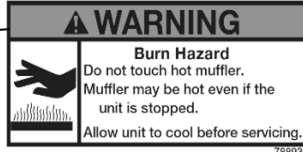
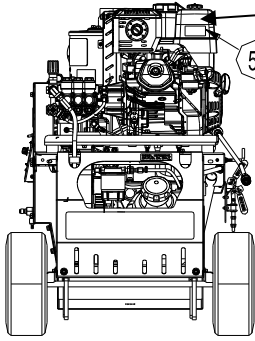
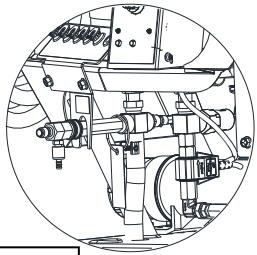
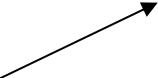
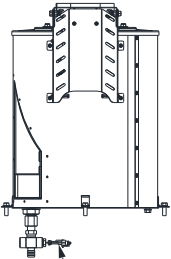



Fig157115_3

Always make sure safety labels are in place and in good condition. If a safety label is missing or not legible, order new labels or unsafe operation could result. **To order replacement safety labels, call NorthStar Product Support at 1-800-270-0810.**

Ref.#	Part #	Description	Qty.
1	782325	Decal, Danger and Warning	1
2	786632	Decal, Rotating Equipment Warning	1
3	798057	Hangtag, Rupture Disk Warning	1
3.1	32821	Lanyard, Hangtag Warning	1
4	797513	Decal, Burn Hazard Decal	1
5	788936	Decal, Burn Hazard Warning	1
6	801160	Decal, Recoil Warning	1
7	802203	Decal, Descaling Warning	1

Special Equipment Safety Features

<p>High Pressure Safety Device (Rupture Disc)</p>	<p>⚠ WARNING: If the high-pressure safety device ever discharges water, turn the engine off and do not use the machine. Call Product Support at 1-800-270-0810.</p> <p>This unit is equipped with a high-pressure</p> <div style="text-align: right;">  <p>Fig157115-R</p> </div> <p>safety feature. If the unloader malfunctions the high-pressure safety device will open and relieve excess system pressure.</p> <p style="text-align: center;">High Pressure Rupture Disc </p>
<p>Temperature Sensor (Thermistor)</p>	<p>This unit is equipped with a Temperature sensor that measures water temperature and automatically turns the burner off when the temperature setting is reached or is at maximum preset limit. When the water temperature drops, the burner automatically reignites.</p> <div style="text-align: right;">  <p>TEMPERATURE SENSOR</p> <p>Fig06831</p> </div>
<p>Thermal Relief Valve</p>	<p>This unit is equipped with a thermal relief valve to protect the pump from overheating. The pump continues to work in bypass mode when you are not spraying. If high temperatures are developed during bypass mode, the thermal relief valve will open and discharge hot water onto the ground, protecting the pump from overheating. The thermal relief valve is located on the unloader bypass port.</p>
<p>Spray Gun Safety Latch</p>	<p>The spray gun is equipped with a built-in trigger safety latch to guard against accidental trigger actuation.</p> <div style="text-align: center;">  <p>00417</p> <p>Safety Latch</p> </div>

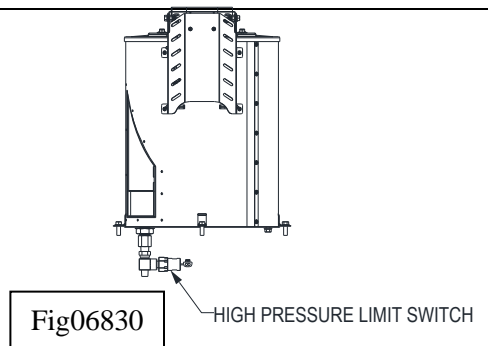

Special Equipment Safety Features

High Pressure Limit Switch

This unit is equipped with a high-pressure limit switch which acts as a primary safety feature. If the system pressure exceeds the set pressure limit this device will stop the burner from firing.

Assembly and Initial Set-Up

STEPS FOR ASSEMBLY / INITIAL SET-UP

STEP 1. UNPACKING & DELIVERY INSPECTION

STEP 2. ASSEMBLY

STEP 3. INITIAL PUMP & ENGINE PREPARATION

Each of these steps is discussed below:

STEP 1. UNPACKING & DELIVERY INSPECTION

Find and separate the components identified in Fig157115_4 – Unpacking, delivery, inspection, assembly and initial set-up and Fig06833 – Hardware Bag. Inspect the pressure washer immediately after you receive delivery for missing parts and damage.

- If you have missing or damaged components, contact Product Support at 1-800-270-0810.

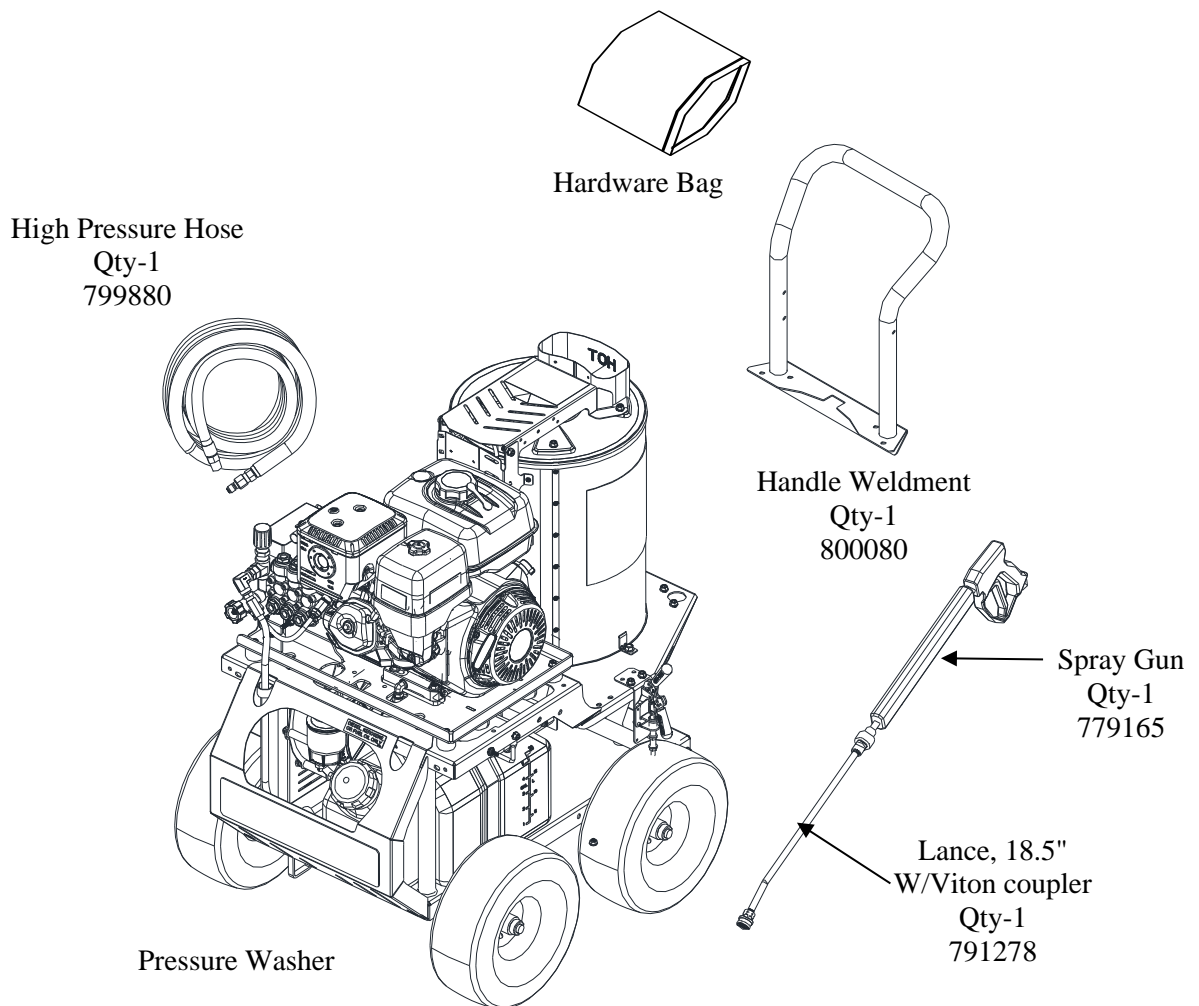
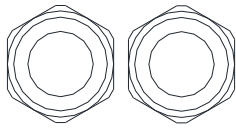

Fig157115_4

Assembly and Initial Set-Up



M8-1.25 Nyloc Nut
Qty-2
Part #777495



Steam Nozzle
Qty-1
Part #801092

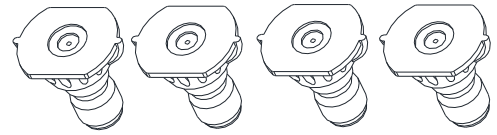

Nozzle Pack
Qty-1
Part #803866

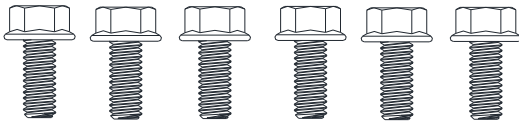

Bolt, 5/16-18 Hex Head Flange Bolt
Qty-6
Part #82621

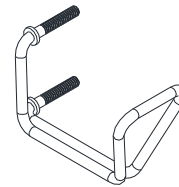

Hose Hook
Qty-1
Part #800615

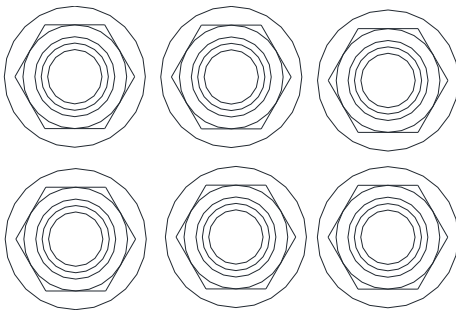

Nut, 5/16-18 Hex Flange Nyloc
Qty-6
Part #82630

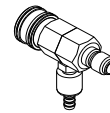

Chemical Injector
Qty-1
Part #779614

1/4" Braided
Chemical Hose
Qty-4'
Part #777165

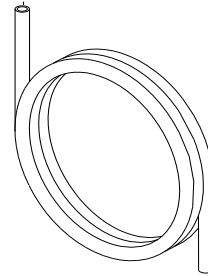

Chemical Strainer
Qty-1
Part #221222

Fig06833

Assembly and Initial Set-Up

STEP 2. ASSEMBLY

You must assemble your pressure washer before it can be used. Refer to Fig157115_6 and follow the steps listed below:

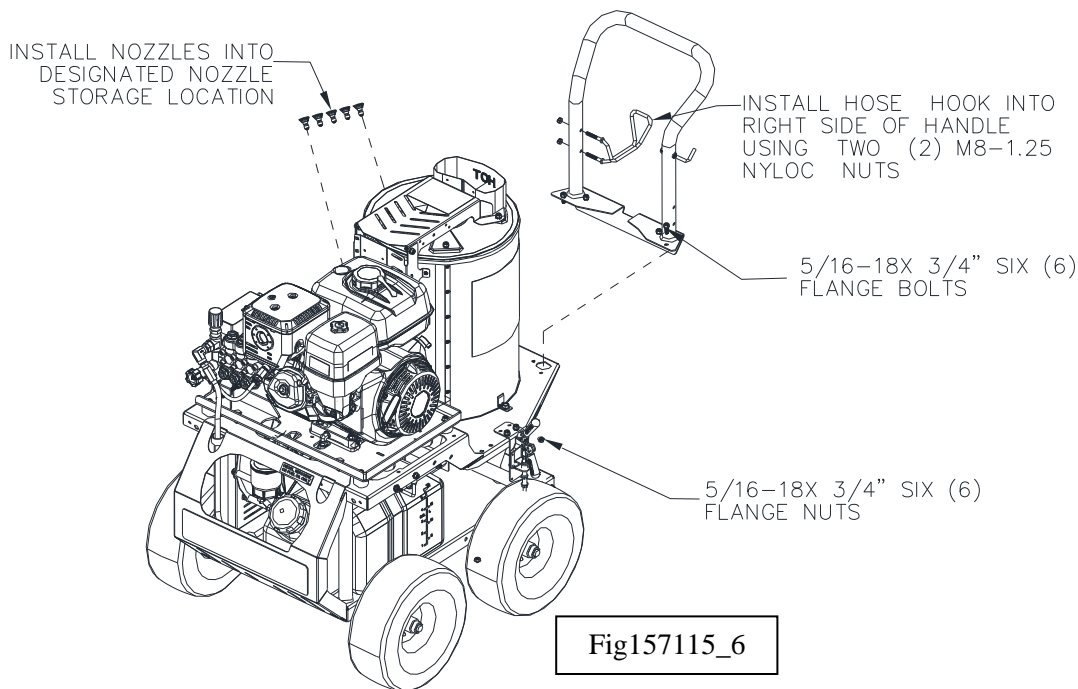

- Step 1.** Install handle with six (6) 5/16-18 x 3/4" Flange Bolts through Base and Handle and secure with six (6) 5/16-18 Flange Nuts.
- Step 2.** Install Hose Hook into right side of Handle using two (2) M8 Nuts.
- Step 3.** Install Nozzles into designated nozzle storage location.

STEP 3. INITIAL PUMP & ENGINE PREPARATION

Prepare Water Pump

Verify pump oil level.

Note: The pump is shipped with oil.

1. Remove shipping tape and black vent plug (if present) from oil fill cap.
2. Verify that oil level is halfway up the sight glass.
3. If oil level is low, fill using SAE 30 non-detergent oil or Cat Pump Oil Item # 22158.

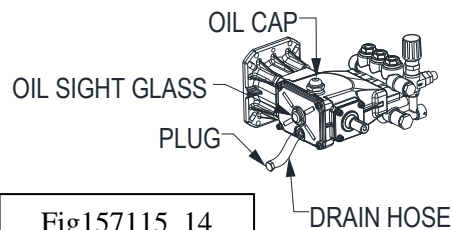

Prepare Engine

Fill the engine with oil.

Note: The engine is shipped without oil.

Refer to the Engine Manual to locate oil-fill port and for instructions on filling. Use the oil grade and quantity specified in the Engine manual. Note: Engine is equipped with an Oil Drain Hose. To account for the volume of the Drain Hose, an additional ounce of oil will need to be added to the quantity specified in the Engine Manual.

Moving and Handling

⚠ WARNING

The pressure washer is heavy. It can crush and cause serious injury if it rolls out of control or tips over. Follow the instructions below for safely moving the pressure washer.

MOVING AND HANDLING

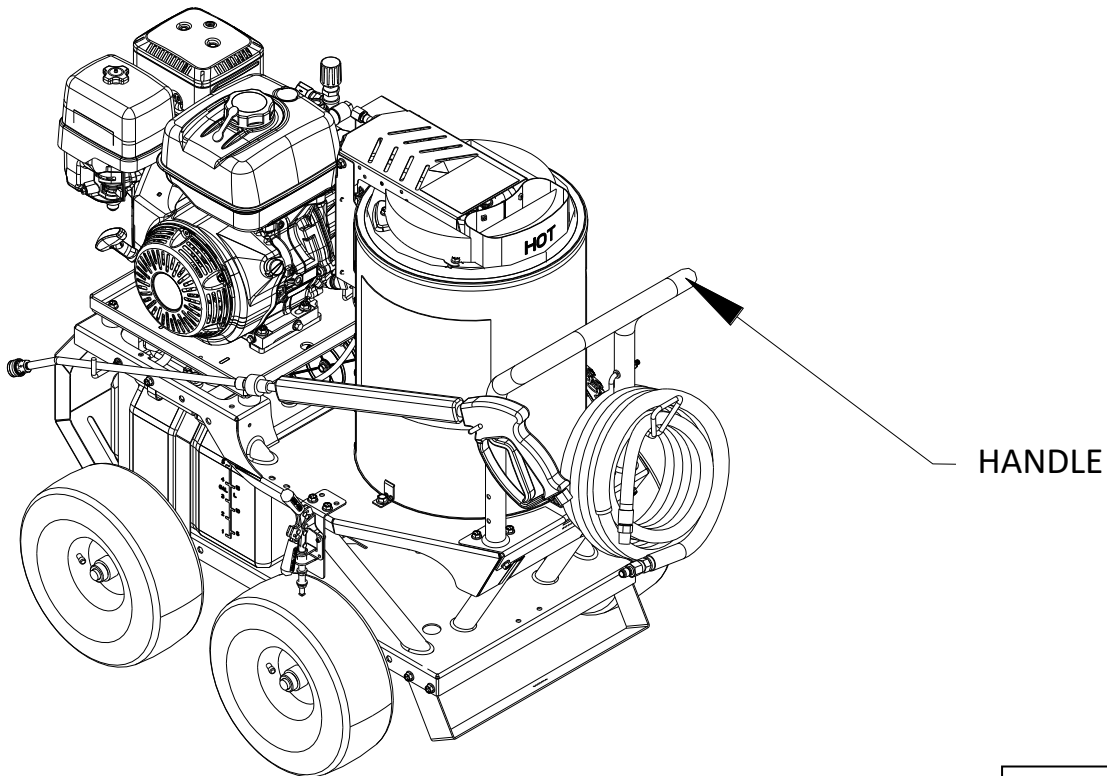

Fig157115_6L

Moving your pressure washer around

1. Use the handle to manually move the pressure washer.
2. To turn, push down slightly on the handle and pivot the pressure washer on its back wheels.
3. Lock wheels with brake to prevent inadvertent movement.

Elevating or lowering your pressure washer

To reduce risk of injury, do not attempt to lift the pressure washer. Use a shallow ramp to raise or lower the pressure washer to a different elevation.

Before Each Use

Follow the steps below prior to each use of the pressure washer.

STEPS TO FOLLOW BEFORE EACH USE

STEP 1. CHECK EQUIPMENT

STEP 2. ADD FUEL(S)

STEP 3. SELECT SUITABLE WORKSITE

STEP 1. CHECK EQUIPMENT

Check/add pump oil	<p>Check/add pump oil. Caution: Never run the pump without sufficient lubrication!</p> <ol style="list-style-type: none"> 1. Check oil level. Verify that oil level is halfway up the sight glass. Remove shipping tape and black vent plug (if present) from oil fill cap. 2. If oil level is low, fill using SAE 30 non-detergent oil or cat pump oil item #22158. 3. Replace fill cap.
Check/add engine oil	<p>Check the engine oil level and add oil as needed.</p> <p>Use the recommended oil type for your engine and expected ambient conditions. (See Specification section of this manual and the engine Owner's Manual for oil type and capacity, and more detailed oil check/fill instructions.)</p> <p>⚠ WARNING: Burn hazard Never open oil port while engine is running. Hot oil can spray over face and body.</p> <p><i>Notes:</i></p> <ul style="list-style-type: none"> ○ Low oil shutdown feature prevents the engine from starting without sufficient oil. ○ Engine is shipped <u>without</u> oil. You must add oil before first use.
Inspect spray system	<p>Always inspect spray system for damage and leaks before each use. Do not start pressure washer until all needed repairs have been completed.</p> <p>⚠ WARNING: High pressure fluid injection hazard High-pressure fluid discharge from leaks (even pin-sized) or ruptured components can pierce skin and inject fluid into the body. Injection injury can result in blood poisoning and/or severe tissue damage leading to infection, gangrene, and possible amputation.</p> <ul style="list-style-type: none"> • Never use a finger or skin to check for leaks. • Never operate machine with damaged or missing hoses/parts. • Never attempt to repair a high-pressure hose or component – Always replace it with a part that is rated at or above the pressure rating of this machine. <p>1) Check hoses, fittings, wand, trigger gun and connections for signs of wear, cracks,</p>

Before Each Use

	<p>looseness, or leaks. Replace as required.</p> <ol style="list-style-type: none"> 2) Check and clean the nozzle orifice. 3) Clean inlet filter. (See Maintenance instructions)
<p>Inspect fuel system</p>	<p>Always inspect (engine and burner) fuel systems & check for leaks BEFORE starting pressure washer.</p> <p>Do not start pressure washer until all needed repairs have been completed.</p> <p>⚠ WARNING: Fuel leak hazard</p> <p>Gasoline and burner fuels are highly explosive and fuel leaks can result in fire or explosions. You can be burned and seriously injured if the fuel system is not properly hooked up or there is a fuel leak when you start the engine.</p> <p>Inspect the entire fuel system. Look for:</p> <ul style="list-style-type: none"> • signs of leaks or deterioration, • chafed or spongy fuel hose, • loose connections, • loose or missing fuel hose clamps, • damaged gasoline tank, or • defective gasoline shut-off valve.
<p>Perform other scheduled maintenance as needed</p>	<p>Make sure that any other regular maintenance has been performed as prescribed in this manual in the “Maintenance & Repair” section.</p> <ol style="list-style-type: none"> 1. Refer to the engine owner’s manual for engine maintenance instructions.

STEP 2. ADD FUEL(S)

⚠ WARNING: Fuel fire/explosion hazard

Gasoline is highly flammable and explosive. **Burner fuels are combustible at warm temperatures.** Heat, sparks, and flames can ignite fuel vapors, which can become widespread during fueling. A flash fire and/or explosion could result and cause serious injury or death. Always use extreme care when handling fuels. Carefully follow all instructions to avoid the following conditions which could result in fuel ignition:

- gas vapor collection inside enclosures
- static electric sparks
- sparks from electric wiring, batteries, or running engines
- sources of heat (such as a hot engine, burner or exhaust)
- open flames, including pilot lights

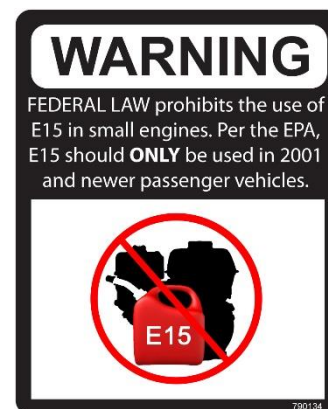

Always follow these general safety rules when fueling:

1) Turn pressure washer off and allow to cool for at least two minutes before removing any fuel cap.

Note: A running, or still-hot engine or burner is hot enough to ignite fuel.

2) Fill fuel tank **OUTDOORS** – never indoors. Fuel vapors can ignite if they collect inside an enclosure and

Before Each Use

explosion can result.

3) Stay away from all sources of heat, sparks, and flames. Do not smoke.

4) Never pump fuel directly into the gas tank or burner at a gas station – it could cause a static electric spark. Follow these steps to avoid static electric sparking during fueling:

- Use an approved portable container to transfer fuel to the pressure washer’s tank. (A portable container made of metal or conductive plastic is preferred because it dissipates charge to ground more readily.)
- Always place container on the ground to be filled. Never fill the portable gas container while it is sitting inside a vehicle, trailer, trunk, or pick-up truck bed.
- Dissipate static charge from your body before beginning the fueling process by touching a grounded metal object at a safe distance from fuel sources.
- Keep nozzle in contact with container while filling. Do not use a nozzle lock-open device.

5) Clean up fuel spills /splashes immediately.

- If possible, move the pressure washer away from spilled fuel on the ground.
- Wipe up spilled fuel and wait 5 minutes for excess fuel to evaporate before starting engine.
- Fuel soaked rags are flammable and should be disposed of properly.
- If fuel is spilled on your skin or clothes, change clothes and wash skin immediately.

Fill engine fuel tank

Check the gasoline tank level. If needed, fill tank with fresh unleaded gasoline from a portable container.

1) Remove engine gas cap.

2) Add gasoline through the fill opening:

- Use only an UL-approved portable gasoline container to transfer the gasoline to engine’s tank.

- Do NOT overfill the gasoline tank. Allow at least 1/2” of empty space below the fill neck to allow for fuel expansion.

3) Replace gas cap securely before starting engine.

4) Store extra gasoline in a cool, dry place in an UL-approved, tightly sealed container.

Fill burner fuel tank (if planning to use heated water)

If you are planning to use heated water, fill burner fuel tank with #1 or #2 diesel, B5 or lower biodiesel, kerosene, or fuel oil.

Note: Always keep at least 1/2 Gallon (approximately .75”) of fuel in the burner fuel tank, even when running in cold mode. This will ensure the burner fuel pump is properly lubricated.

1) Remove diesel fuel cap.

2) Add fuel through the fill opening. Do not overfill. Allow at least 1/2” of empty space below fill neck to allow for fuel expansion.

3) Replace fuel cap securely before starting engine.

4) Wipe any excess fuel from unit before starting.

Before Each Use

STEP 3. SELECT SUITABLE OUTDOOR WORKSITE

Before using the pressure washer, you must understand the criteria for selecting a suitable location for operation. Note that this pressure washer is for OUTDOOR USE only.

WARNING:

You must choose a suitable site for operating your pressure washer to avoid equipment damage and/or injury and possible death from carbon monoxide poisoning, fire/explosion, uncontrolled equipment movement/tip over, or slips and falls. Choose a site that meets all of the following five criteria:

1. OUTDOORS only, and away from all building windows and air intakes.
2. Where no flammable vapors, dusts, and gases are present.
3. Where there is adequate, unobstructed ventilation airflow.
4. With adequate clearance from combustible materials.
5. On a firm, level, heat-resistant surface with good drainage.

Detail regarding each of these criteria are provided below.

1. Outdoors ONLY

DANGER: Carbon monoxide poisoning hazard

Exhaust fumes from both the engine and the burner contain carbon monoxide (CO), a poisonous gas you cannot see, smell, or taste. The CO generated by the pressure washer can rapidly accumulate, even in areas that appear to be well ventilated, resulting in dangerous and fatal concentrations within minutes. Follow the directions below for choosing a location to operate your pressure washer in order to avoid carbon monoxide poisoning.

The location you choose to operate the pressure washer must be OUTDOORS and at least 20 feet from the home, away from windows, vents and air intakes, to allow proper ventilation. If you start to feel sick, dizzy, or weak while using the pressure washer, shut off the engine and get to fresh air RIGHT AWAY.

- Never run the pressure washer in an enclosed or partially enclosed location such as a building, garage, barn, shed, or house. *These spaces can trap poisonous gases. Running a fan or opening windows will not provide adequate ventilation to prevent dangerous CO build-up.*
- Only use the pressure washer outdoors and far away from open windows, doors, and building or vehicle vents.
- Place the pressure washer so that the exhaust fumes will not be directed towards people or building air intakes.
- Ensure that working, battery-operated or battery back-up carbon monoxide alarms are used in any dwelling/structure that is in close proximity to the running pressure washer.
- Note that this pressure washer is NOT designed or approved for use in vehicles or marine applications. Never run the pressure washer inside RVs or other vehicles, on boats, or on pick-up truck beds.

WARNING:

Never attempt to attach ductwork to the engine muffler or burner exhaust to allow for installation inside an enclosure. This could cause hot air deflection, heat build-up, and increased exhaust backpressure, resulting in possible exhaust leakage or overheating and damage to the pressure washer.

Before Each Use

<p>2. Away from combustible dust, liquids, or vapors</p>	<p>Do not locate and use the pressure washer in the presence of flammable vapors, dust, gases, or other potentially combustible materials. Burner is an open flame, which can ignite airborne dusts and flammable vapors. Operate only where open flame or torch is permitted.</p>
<p>3. Adequate ventilation airflow</p>	<p>The pressure washer needs adequate, unobstructed flow of air to allow for proper combustion and adequate cooling. Proper combustion can only be obtained when there is a sufficient supply of oxygen available for the amount of fuel being burned. Cooling ventilation is required to prevent overheating of the pressure washer and possible fire.</p> <ul style="list-style-type: none"> • Situate so there is adequate clearance around pressure washer to allow for airflow – at least 7 feet from any non-combustible wall or obstruction. • Never place any objects against or on top of the pressure washer. • Do not operate with a tarp, blanket, or cover surrounding the pressure washer.
<p>4. Hot exhaust clearance</p>	<p>The exhaust gas from your pressure washer is extremely hot and can cause combustible materials to catch on fire.</p> <ul style="list-style-type: none"> • Make sure both the engine exhaust and burner exhaust are at least 7 feet from all combustible materials and structures during operation. • Equip the engine with a spark arrestor if the pressure washer will be used near any ignitable forest, brush, or grassy land. (See the engine manual provided with this equipment to determine if the engine is already equipped.) Make sure you comply with applicable local, state, and federal codes. • Keep a fire extinguisher rated “ABC” nearby. Keep it properly charged and be familiar with its use.
<p>5. Firm, level, heat-resistant surface with nearby water supply</p>	<p>The pressure washer should be positioned on a firm, level (less than 3-degree slope), heat-resistant surface with good drainage and a nearby water supply. The pressure washer should be placed within garden hose distance of a continuous water supply. Ensure that the pressure washer sits level and will not slide or shift during operation. If applicable, block the pressure washer’s wheels to prevent movement. Surface should be heat resistant if you will be using the burner for heated spray.</p>

Operation

After you have checked and fueled the equipment and positioned it in a suitable worksite, it is time to start your pressure washer. The following are the procedures necessary for safe, successful operation of your pressure washer.

⚠ WARNING

Carefully read and make sure you understand all instructions and safety information before using the pressure washer. Improper use of the pressure washer can result in *serious injury or death* to the operator or bystanders from:

- *Carbon monoxide poisoning*
- *Fire/explosion*
- *Chemical exposure*
- *Skin/eye injury from high pressure spray*
- *Burns*
- *Slips/falls*
- *Electric shock*
- *Flying objects/debris*

OPERATING INSTRUCTIONS

STEP 1. CONNECT HOSES, WATER SUPPLY, AND SPRAY NOZZLE

STEP 2. SET UP FOR CHEMICAL SPRAY (IF DESIRED)

STEP 3. SPRAYING

STEP 4. STOPPING

Each of these procedures is discussed in detail below:

STEP 1. CONNECT HOSES, WATER SUPPLY, AND SPRAY NOZZLE

Position pressure washer for use

Place pressure washer in a suitable location for use, as directed in the “Before Each Use, Step 3: Select Suitable Worksite” section of this manual. A suitable location is:

- OUTDOORS only, away from all building air intakes.
- Where no flammable vapors, dusts, and gases are present.
- Where there is adequate, unobstructed ventilation airflow.
- With adequate clearance from combustible materials.
- On a firm, level, heat-resistant surface with good drainage and nearby access to a continuous water supply.

⚠ DANGER: Carbon monoxide poisoning hazard

Exhaust fumes from both the engine and the burner contain carbon monoxide (CO), a poisonous gas you cannot see, smell, or taste. The CO generated by the pressure washer can rapidly accumulate, even in areas that appear to be well ventilated, resulting in dangerous and fatal concentrations within minutes. **ONLY** run pressure washer **OUTDOORS** and at least 20 feet from the home, away from windows, vents and air intakes, to allow proper ventilation. If you start to feel sick, dizzy, or weak while using the pressure washer, shut off the engine and get to fresh air **RIGHT AWAY**. **NEVER** run pressure washer inside any enclosed or semi-enclosed spaces, including homes, garages, basements, sheds, boxes, pick-up truck beds, RVs, or boats. These spaces can trap poisonous gases, **EVEN** if you run a fan or open windows.

Operation

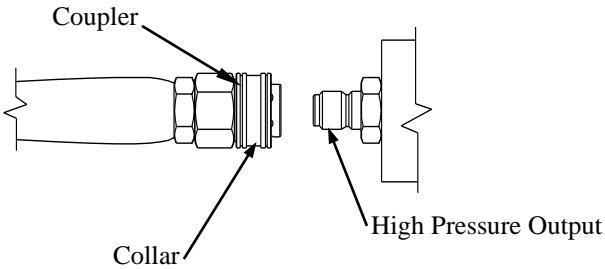
<p>Attach garden hose to water supply</p>	<p>Acquire a suitable garden hose and attach to the water supply.</p> <ol style="list-style-type: none"> 1. Acquire a suitable garden hose: <ol style="list-style-type: none"> a. The water supply garden hose must have an inside diameter of at least 5/8". If the hose is more than 100 ft. long, the diameter must be at least 3/4". b. Always use a flexible rubber hose for your water supply. Do not use rigid piping. c. The use of a backflow preventer on the supply hose is recommended and may be required by local code. 2. Attach garden hose to water supply.
<p>Check water supply</p>	<p>Check adequacy of water supply. Water supply should be standard tap water.</p> <ol style="list-style-type: none"> 1. Make sure the water supply is clean. Debris can cause excess pump wear and reduce performance. 2. Make sure the water supply is steady and capable of flowing at a rate 20% over the rated flow of your pump. An insufficient water supply will damage your pump. Use a stopwatch to time how long it takes to fill a 5-gallon bucket with your garden hose. It should take less than 100 seconds.
<p>Attach garden hose to garden hose inlet</p>	<p>Attach garden hose to garden hose inlet.</p> <ol style="list-style-type: none"> 1. See "Component Identification" section of this manual for location of garden hose water inlet. 2. Confirm rubber washer and inlet screen are in the garden hose inlet before attaching the garden hose.
<p>Attach high pressure hose</p>	<p>Attach the high-pressure hose to the pressure washer's high-pressure outlet.</p> <p>⚠ WARNING: NEVER operate this pump with components (such as hose, connections, and spray gun) rated for lower pressure and/or temperature limits than the machine's maximum rated pressure and temperature, or component could rupture and cause serious personal injury from escaping high pressure fluids.</p> <ol style="list-style-type: none"> 1. See "Component Identification" section of this manual for location of the pressure washer's high-pressure outlet. 2. Your pressure washer hose is equipped with quick couplers. Simply pull the collar back and push the coupler onto the water outlet nipple. (Fig. 8a). The collar should slide over the ball bearings. <div style="text-align: center;">  </div> <div style="text-align: right; border: 1px solid black; padding: 2px; width: fit-content;"> <p>Fig. 8a</p> </div>

Operation

3. Release the collar, making sure it springs back and re-seats to its original (non-retracted) position. (Fig. 8b). *Check the connection by pulling on the hose to ensure a positive connection.*

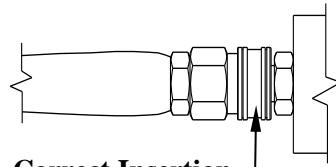

Correct Insertion

Collar Seated

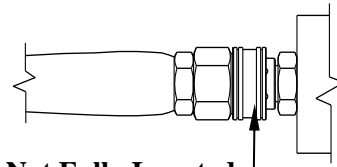

Not Fully Inserted

Collar NOT Seated

Fig. 8b

Select spray nozzle

Your pressure washer is equipped with four high-pressure nozzles and one steam nozzle. Generally, the wider the spray angle of the nozzle, the lower the spray impact produced. Select the appropriate nozzle for the job based on the following table:

Part #	Nozzle # and Color of Nozzle:	Spray Angle	Used For:
782120	4.5 Yellow	15°	Tough Stains/Stripping
777844	4.5 Green	25°	General
778737	4.5 White	40°	Light Cleaning
778949	Soap Nozzle	65°	Chemicals
801092	3.5 Orange Steam	15°	Steam

Note: You must use the black low-pressure nozzle for spraying chemicals.

Attach nozzle

Attach nozzle to the spray gun.

⚠ WARNING: Depressurize first

Any time you remove/install/change a nozzle, you must depressurize hose line by squeezing the spray gun trigger while the engine is off. Even if the engine has been off for a long period of time, the hose may remain dangerously pressurized.

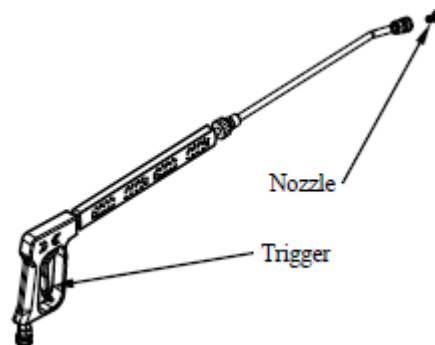

1. Make sure the engine is off and the hose line depressurized.
2. To install the nozzle, pull the collar back and twist the nozzle firmly into the coupler on the end of the wand. (Fig. 9a)

Operation

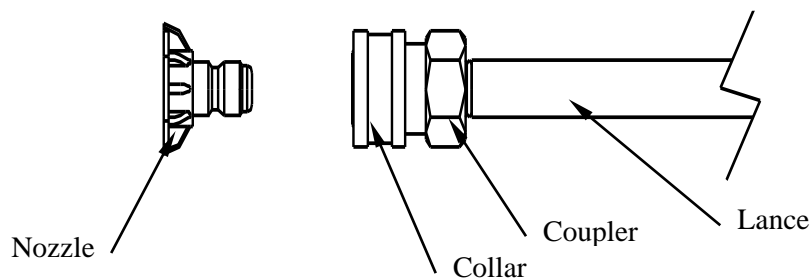

Fig. 9a

3. Release the collar, making sure it springs back and re-seats to its original (non-retracted) position. (Fig. 9b). *Check the connection by pulling on the nozzle to ensure a tight connection -- if correctly inserted, nozzle will rotate but not pull out.*

⚠ WARNING:

Make sure the nozzle is correctly inserted. Sprayer nozzle can become a projectile and cause serious personal injury or property damage if not properly connected to the spray gun. Do not attempt to use different types of nozzles that may not fit the coupler.

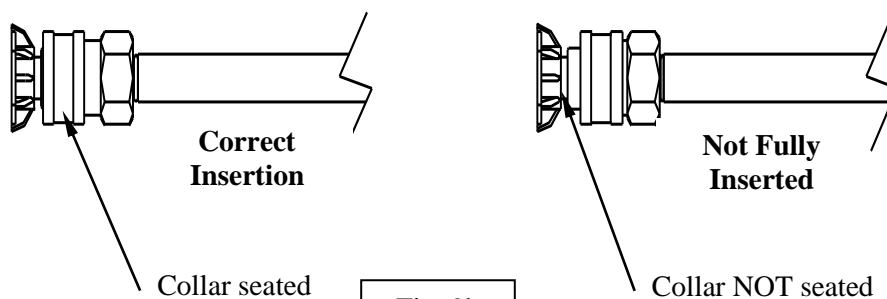

Fig. 9b

STEP 2. SET UP FOR CHEMICAL SPRAY (IF DESIRED)

Using the proper cleaning chemical for the application can speed up cleaning jobs tremendously.

Your pressure washer is equipped with a chemical injection point on the downstream side of the pump for introducing cleaning chemicals into the water stream. A braided chemical hose is provided to connect at this point. Suction pressure at this connection automatically draws the chemical solution in through the hose, mixing in 1 part chemical to 15 parts water. Adequate suction pressure is created only when the low pressure (black) spray nozzle is used.

The introduction of cleaning chemicals via the chemical injection point affords the following advantages:

- It protects the pump from damage because no chemical passes through the pump.

CAUTION: Certain chemicals, such as bleach or those containing muriatic acid, will cause pump damage if introduced upstream through the pump's water inlet.

Operation

- It mixes the cleaning chemical into a low-pressure spray. Cleaning chemicals applied under low pressure adhere better to the surface being cleaned, allowing the formula time to react and remove dirt more effectively.

Note: An external *chemical injector pump* is not recommended for use with this pressure washer, and if used would obviously alter the 15 to 1 dilution ratio.

⚠ WARNING: Chemical spraying

- Never spray acids, corrosives, or abrasive or flammable liquids. Breathing hazards, surface burns/corrosion, or fire/explosion could result.
- Follow the chemical manufacturer’s label instructions for proper use and handling of the chemical. Understand all safety hazards and first aid for all chemicals being used. Always wear protective gloves when handling and cleaning with chemicals and wear other protective gear as directed by chemical manufacturer. Always dispose of hazardous fluids per local, state, and national guidelines.

Acquire cleaning chemical

Use only NorthStar pressure washer chemicals or chemicals specifically formulated for use with pressure washers.

CAUTION: Non-approved chemicals can damage pressure washer components (seals, wand, hoses, pump, etc.) and be harmful to the environment.

Prepare for chemical spray (if planning to use)

Prepare the pressure washer for chemical spraying using the following steps:

1. Prepare (dilute) chemical cleaning solution as required for the job.

(Note: the chemical solution will be automatically mixed with the water at a ratio of 15 parts water to 1 part chemical solution.)

2. Press the braided chemical hose over the chemical injector not on pump.

3. Submerge the suction strainer connected to the braided chemical hose into a bucket containing the chemical solution.

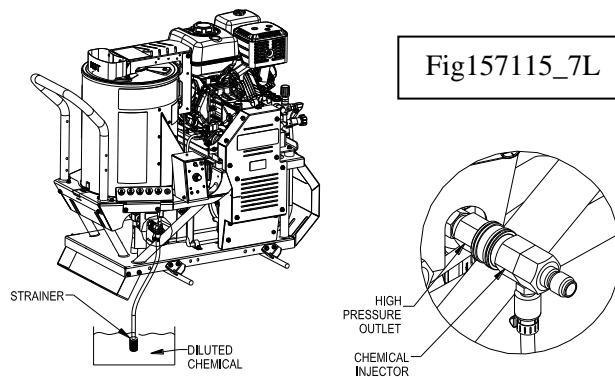

STEP 3. SPRAYING

Safety rules for operation

Before starting the pressure washer, review the following general safety rules for operation:

Conditions for Use

Know how to stop. Be thoroughly familiar with proper use of the equipment and all controls and connections. Know how to stop the pressure washer and depressurize system quickly if needed (see “Step 4. Stopping”).

Operation

Instruct all operators. The pressure washer's owner must instruct all operators and potential renters in safe set-up and operation. Do not allow anyone to operate the pressure washer who has not read the Owner's Manual and been instructed on its safe use.

Adult control only. Only trained adults should set up and operate the pressure washer. Do not let children operate. Pressure washers can generate forces greater than children can control and require judgment beyond what can be expected of children.

Under the influence. Never operate, or let anyone else operate, the pressure washer while fatigued or under the influence of alcohol, drugs, or medication.

Safety equipment / controls in place. Do not operate the pressure washer unless all safety covers, guards, and barriers are in place and in good working order, and all controls are properly adjusted for safe operation.

Damaged. Do not operate the pressure washer with damaged, missing, or broken parts. Never attempt to repair a high-pressure hose or component. Always replace it with a part that is rated at or above the pressure rating of the machine.

Modifications. Do not modify the pressure washer in any way or deactivate any safety device. Do not change or add to fuel tank, fuel lines, or exhaust system. Modifications can result in hazards related to carbon monoxide poisoning, fuel leaks, fire, explosion or other serious safety hazards, and will also void the warranty.

During Use

Stay alert. Watch what you are always doing.

Clear work area. Clear the work area of all bystanders. Keep children and pets away.

Keep spray away from electrical wiring. Spray contact with electrical wiring will likely result in severe electrical shock or electrocution.

Hot exhaust/parts. Stay clear of engine and burner exhausts. Never touch hot engine muffler, burner/heating coil, or other hot surfaces. All are very hot and will burn you.

Do not direct spray at this machine. Do not attempt to clean this machine with its own spray. Engine damage will result. Cleaning should be done with a damp sponge with the engine OFF.

Let engine cool at least two minutes before refueling.

Avoid inhalation of exhaust. This product emits CO and chemicals known to the State of California to cause cancer, birth defects or other reproductive harm.

Never pull by hose. Do not move this machine by pulling on the hose. Hose or connections could fail and result in catastrophic high-pressure release of fluid as well as hose whipping.

Avoid sharp objects. Keep hose away from sharp objects. Bursting hoses may cause injury.

No load bearing. Do not use the pump to support other items of equipment that impose unacceptable loads on the pump. Do not attempt to use this machine as a prop.

Lock trigger safety latch when not spraying. Spray gun is equipped with a built-in trigger safety latch to guard against accidental trigger release. Rotate safety latch to the locked position when not spraying.

Leaving unattended. Always turn off the pressure washer and relieve system pressure before leaving the sprayer unattended.

Prompt Emergency Response

Seek medical aid for suspected injection injury. If injured by high-pressure fluid, no matter how small the wound is, see a doctor at once. A typical injection injury may

Operation

	<p>be a small puncture wound that does not look serious. However, severe infection or reaction can result if proper medical treatment is not administered immediately by a doctor who is familiar with injection injuries.</p> <p>Seek medical aid for suspected carbon monoxide poisoning. The running engine gives off carbon monoxide, a poisonous gas that can kill you. If you start to feel sick, dizzy, or weak while using the pressure washer, shut off the engine and get to fresh air RIGHT AWAY. See a doctor. You may have carbon monoxide poisoning.</p>
<p>Put on personal protective gear</p>	<p>⚠ WARNING: Use personal protective gear to prevent:</p> <ul style="list-style-type: none"> - Eye and skin injection injury from high pressure spray - Burns from hot water or steam - Eye injury from flying debris <ol style="list-style-type: none"> 1. Wear waterproof, thermally insulated gloves, safety glasses with side and top protection, face protection, and protective clothing when operating the machine. If spraying pressure washer specific chemicals, wear a respirator mask to avoid inhalation of vapors if directed on the chemical label. 2. Wear non-slip, protective footwear. Use of pressure washer can create puddles and slippery surfaces. Wear footwear capable of maintaining a good grip on wet surfaces.
<p>Prime the water supply</p>	<p>Turn on water supply and squeeze the trigger.</p> <p>CAUTION: Never run the pump without the water supply connected and turned on. Operating the pressure washer without a sufficient incoming flow of water will damage the pump.</p> <ul style="list-style-type: none"> • Turn on the water supply. Make sure the water supply is steady and flowing at a rate 20% over the rated flow of your pump. (See Step 1, “Connect Hoses, Water Supply, and Nozzle”). • Make sure tank is completely full and air is purged from the water supply line between the water tank and pump. This may require loosening the hose clamp at the pumps inlet to allow air in the hose to escape so water can flood the pump inlet. If this step is needed ensure clamp is retighten before starting the engine. (Supply line leaks and air in the hose can cause damage to the pump, so always make sure all the air is out supply lines and clamps are tight before starting. • Make sure the water supply hose is not kinked. A kinked hose will provide insufficient water supply to the pump and reduce its life. Make sure the hose remains unkinked after moving the pressure washer.
<p>Start engine</p>	<p>Start the engine to power the pump.</p> <ol style="list-style-type: none"> 1. Make sure water supply is connected and primed. CAUTION: Running the pump dry will cause damage and void the warranty. 2. To prevent accidental spraying, engage the safety latch on spray gun trigger by rotating it to the locked position.

Operation

	<p>3. Follow the instructions in the Engine Manual for starting the engine.</p> <p>⚠ DANGER: Do not inhale engine exhaust. It contains dangerous carbon monoxide that can kill you.</p>
<p>Apply cleaning chemical (if desired)</p>	<p>If desired, spray cleaning chemical at low pressure (with or without heated water).</p> <ol style="list-style-type: none"> 1. Make sure the chemical injector is properly set up according to the instructions in Step 2, "Set Up for Chemical Spraying". 2. Make sure the low-pressure BLACK nozzle is attached before beginning to spray chemicals -- <i>Only the low-pressure black nozzle will allow chemicals to be drawn through the chemical injector into the water stream.</i> 3. You can apply chemicals with either warm or cold water. Check chemical label. If warm water is specified, start burner according to instructions provided below. 4. Apply chemicals by squeezing the spray gun trigger. The chemical injector will draw the chemical into the water stream. 5. Apply chemicals evenly to the cleaning surface. Never use more chemical than is necessary to clean the surface. 6. Allow the chemicals time to react with the dirt before rinsing. 7. Prepare to rinse by changing to a high-pressure nozzle. Changing the nozzle from the low-pressure black nozzle to a high-pressure nozzle will stop the flow of chemicals into the water stream. <i>Refer to instructions in section select spray nozzle in Step 1, "Connect Hoses, Water Supply, and spray Nozzle".</i> 8. Rinse with high-pressure spray, either hot or cold, as instructed below.
<p>Turn on burner (If hot spray or steam is desired)</p>	<p>If HOT spray or steam is desired, turn on the burner:</p> <ol style="list-style-type: none"> 1. First make sure vicinity is free of flammable vapors, dust, gases, or other potentially combustible materials. Operate only where open flame or torch is permitted. 2. Make sure there is fuel in the burner fuel tank. CAUTION: Do not run the machine in hot mode without fuel in the burner's fuel tank, or damage can occur. Always keep at least 1/2 gallon (approximately .75") of fuel in the burner fuel tank, even when running in cold mode. This will ensure the burner fuel pump is properly lubricated. 3. Make sure the engine throttle is all the way open. If it is not, the engine will not supply adequate air to the burner, resulting in smoke coming from the heat exchanger during operation. Turn the heat switch ON and adjust the thermostat to the desired temperature. (For steam spraying, set the temperature at 212°F or higher and use orange steam nozzle.)

Operation

	<p>⚠ WARNING:</p> <ul style="list-style-type: none"> • NEVER attempt to immediately run or re-light the burner if it does not ignite the first time. Unburned fuel or gas in burner may have accumulated, causing potential explosion or fire hazard. • Do not attempt to set temperature limit above the preset limit. • Never touch hot burner surfaces and stay clear of burner exhaust. All are extremely hot and will burn you. • Do not inhale burner exhaust. It contains dangerous carbon monoxide that can kill you. <p>4. The burner will fire when the trigger is squeezed – follow instructions for spraying.</p> <p><u>Note:</u> If burner exhaust is white, adjust burner for peak performance. See the “Oil Burner Adjustment Instructions” step in the “Burner Adjustment” section of this manual.</p> <p>5. When the trigger is released, a flow switch automatically turns the burner off. Also, when the temperature setting is reached, the thermostat automatically turns the burner off.</p> <p>⚠ WARNING: It is important that the burner stops firing when the trigger is released. If the burner remains firing, discontinue use until the pressure washer is serviced. Extremely high temperatures can result in serious injury and equipment damage.</p>
<p>Begin high pressure spray</p>	<p style="text-align: center;"><u>High Pressure Spray Procedure</u></p> <p>⚠ WARNING: High pressure spraying safety</p> <ul style="list-style-type: none"> • Keep spray away from people. Never direct discharge stream at or near any person. Do not allow any part of the body to come in contact with the fluid stream. High-pressure spray can cause serious skin, eye, or falling injuries, and hot water can burn. Injection injury will occur if high-pressure spray pierces the skin, injecting liquid under the skin. Injection injury can result in blood poisoning and/or severe tissue damage leading to infection, gangrene and possibly amputation. Seek medical attention. • Do not secure trigger open. To reduce risk of injury, do not attempt to secure the spray gun open by blocking or tying the spray gun in the open position. • Prevent slips / loss of balance. High-pressure spray could cause you to lose balance from kickback forces, and wet surfaces can be slippery. <ul style="list-style-type: none"> - Always keep good footing and balance. Do not overreach. - Do not stand on unstable support when spraying. - If spraying from an elevated surface, use fall protection because spray gun kickback can propel you off the elevated surface. When spraying from a ladder or scaffolding, ensure it is firmly anchored from sway or tip-over. - Be aware of puddles and slippery surfaces. Ensure there is adequate drainage to prevent pooling of water.

Operation

- **Prevent surface damage & flying debris** – Surfaces being sprayed must be strong enough to withstand high-pressure spray or damage may result. In addition, high-pressure spray will dislodge unsecured objects as well as surface chips and debris, resulting in hazardous flying objects that can cause personal injury or property damage. Do not spray brittle surfaces or breakable, fragile, or unsecured objects such as:
 - stucco or laminar flagstone
 - some painted surfaces
 - windows or glass doors (because they may break)
 - light fixtures, flowerbeds, mailboxes
 - unsecured, lightweight objects

Procedure:

1. Put on one of the high-pressure spray nozzles (always relieve system pressure first and follow instructions for attaching a nozzle).
2. Clear the cleaning area of all persons. Keep children and pets away.
3. Hold the spray gun firmly with two hands and a sturdy stance -- Gun kicks back when triggered.

⚠ CAUTION:

Spray gun metal gets extremely hot when using the burner and can burn you on contact. Never touch the metal screw or any metal parts of the spray gun when the heater is being used. Use only designated grip areas.



4. Wash from the bottom to the top, using side-to-side motions. This washes away heavy dirt and allows the detergent to soak as you work toward the top.
5. Use the width of the spray pattern to wash a wide path. Overlap spray paths for complete coverage.
6. The nozzle should be 12” to 24” from the work, closer for tough areas.
7. Small parts should be washed in a basket, so the pressure does not push them away. Larger, lightweight parts should be clamped down.
8. The pressure washer is set and locked to the maximum rated pressure when it leaves the factory. To reduce the pressure, turn the unloader knob counterclockwise. (See Fig157115_8 below)

⚠ WARNING:

Do not attempt to alter the unloader valve's maximum pressure. Excess pressure could cause serious injury from escaping high-

Operation

pressure fluids and/or pump damage. Any alteration other than turning the adjustment knob will void your warranty.

UNLOADER

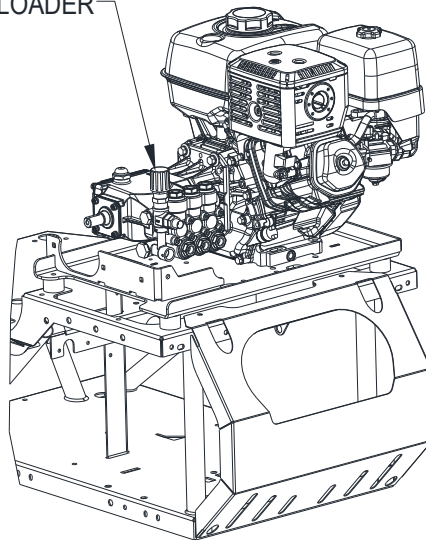

Fig157115_

9. If temporarily interrupting spraying, rotate trigger safety latch downward to the locked position to guard against accidental trigger release.
10. Always turn off the engine and activate spray gun trigger to relieve system pressure when:
 - the sprayer is unattended, or
 - disconnecting hoses, installing/cleaning nozzles, or servicing the pump.

⚠ WARNING:

Always turn off the engine and relieve system pressure when finished spraying or when leaving sprayer unattended. Serious injury could result from unintentional release of high-pressure spray.

STEP 4. STOPPING

Stop the engine using the following steps:

⚠ WARNING:

Never disconnect the high-pressure hose from the high-pressure outlet or spray gun while the system is pressurized. Relieve pressure by squeezing the spray gun trigger after the engine is turned OFF.

1. If the heater was used, turn heat switch OFF and run cold water through the coil for at least 2 minutes while spraying.
2. Turn engine OFF.
3. Turn water supply OFF.
4. Actuate spray gun trigger to relieve system pressure.
5. Remove garden hose.
6. Remove pressure hose. Remove nozzle from spray gun.
7. Turn gasoline line valve to the OFF position.
8. Cool engine at least five minutes before storing -- A hot engine is a fire hazard.

Storage

STORAGE

When you are finished using the pressure washer, you must prepare the sprayer for storage and store it in a proper location. Note:

- **If you will be storing the sprayer in freezing conditions**, follow the instructions for preparing the sprayer for storage in freezing conditions.
- **If you will not be using the sprayer again for 30 days or more**, follow the instructions for preparing the engine for long-term storage.

⚠ WARNING

- **Fuel and its vapors can ignite and cause a fire.** Select a well-ventilated storage area away from sources of heat, flame, or sparks.
- **A hot engine can ignite flammable materials.** Always let engine cool at least five minutes before storing.

Detailed instructions are provided below.

Choose a storage location	<p>Choose a storage location that is:</p> <ul style="list-style-type: none"> ○ Clean and dry. ○ Away from sources of heat, open flames, sparks, or pilot lights, even if the pressure washer's engine and burner fuel tanks are empty. Residual fuel fumes from tank can ignite. ○ Away from extreme high or low temperatures. Do not store the pressure washer in freezing conditions unless it is prepared as directed below for those conditions.
Perform regular maintenance	<p>Perform periodic maintenance as directed in this manual to keep the pressure washer in safe working condition. See maintenance schedule under maintenance and repair section of the maintenance.</p>
Prepare pressure washer for freezing conditions (if needed)	<p>If you will be storing the pressure washer in freezing temperatures, you must properly prepare the pressure washer to prevent water from freezing in the system.</p> <p>⚠ CAUTION: Do not allow water to freeze in the pressure washer, high-pressure hose, or spray gun. Freezing water can cause damage to the equipment and cause the spray gun to fail in the open position. A spray gun that has failed in the open position can whip around and cause personal injury when the pressure washer is started.</p>

Storage

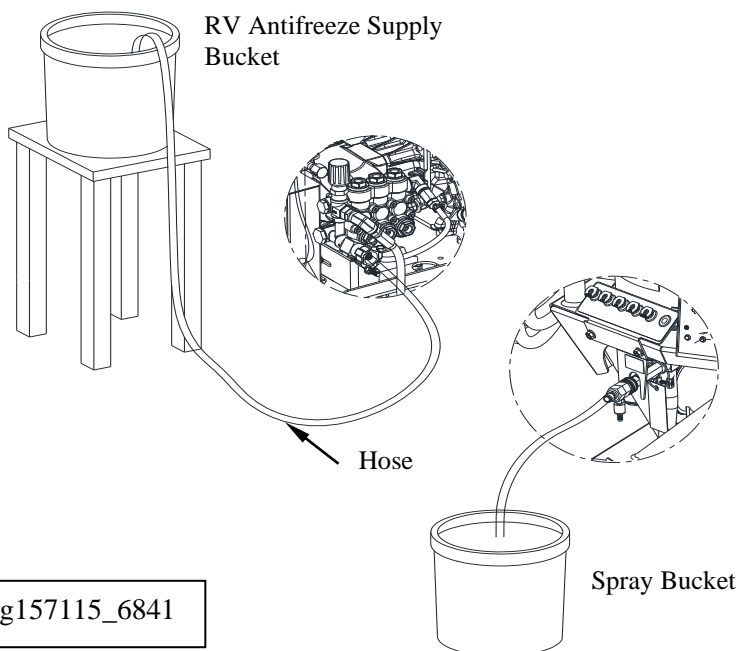

Fig157115_6841

Materials list:

- 1) Two 5 gallon buckets
- 2) 4-5 foot long garden hose or equivalent (recommend 5/8" to 3/4" diameter with male 3/4" Garden hose threads on one end)

Procedure:

- 1) In a 5 gallon pour at least 2 gallons of environmentally safe antifreeze. Note: whether using undiluted or pre-diluted antifreeze, follow manufactures mixing guidelines to ensure proper freeze protection.
- 2) Elevate bucket so it is higher than the unloader.
- 3) Connect a 4-5 foot long garden hose or equivalent to inlet connection.
- 4) To ensure good priming fill hose with water or antifreeze mix before placing end into 5 gallon bucket of antifreeze.
- 5) With the nozzle removed, trigger gun off, and with burner off point trigger gun into a second empty 5 gallon bucket and start the unit.
- 6) With unit running, spay into the empty bucket for several seconds then release trigger for 2 seconds. Continue cycling the trigger gun multiple times until all the antifreeze has be drawn from the supply bucket. Note: if system was completely flushed you should see antifreeze in the spray bucket. We recommend lowering the engine rpm to 1/2 or 1/4 throttle during this step to help assist in priming.
- 7) With unit shut off, remove hoses and drain excess antifreeze into spray bucket.
- 8) Properly dispose of antifreeze according state EPA laws.

Storage

	<p>Alternately the system can be blown out with compressed air: <u>Note:</u> although this method can be effective for winterizing, the above antifreeze method is preferred because it ensures the entire plumbing system is flushed and lubricated.</p> <p>Materials:</p> <ol style="list-style-type: none"> 1) Properly rated fittings (80 psi or higher) to connect air supply to inlet connection (3/4" garden hose) on pressure washer. 2) Air compressor with regulator able to set pressure between 60-80 psi. <p>Procedure:</p> <ol style="list-style-type: none"> 1) Connect hose and gun to outlet connection. 2) Connect air supply to inlet connection, ensuring regulator is set no higher than 80 psi. 3) Pull trigger on gun (with nozzle removed) and allow air to push water out of plumbing. Continue hold trigger gun open until water stops coming out of. 4) Turn off air compressor and pull trigger on gun to relieve any trapped pressure in the system. 5) Disconnect air compressor, hose, and trigger gun. 6) Remove thermal relief valve located at the bottom of the unloader (see Component identification page), and allow water from the bypass loop to drain out. Once drained reinstall thermal relief fitting.
<p>Prepare engine for long term storage (if storing more than 30 days)</p>	<p>First prepare the engine for long-term storage if you will not be using the pressure washer again for more than 30 days. Fuel can become stale when stored over 30 days. Stale fuel causes acid and gum deposits to form in the fuel system, which can cause malfunction of the engine.</p> <ol style="list-style-type: none"> 1. Prepare fuel system for storage: <ul style="list-style-type: none"> ○ Drain all gasoline from the tank and carburetor. This is most easily accomplished by <i>running the pressure washer with the high-pressure hose</i> until the engine stops from lack of fuel. <u>OR</u> ○ Add fuel stabilizer to the gasoline (following manufacturer's instructions) <ul style="list-style-type: none"> <u>Fuel stabilizer steps:</u> <ol style="list-style-type: none"> a. Ensure gas tank is full. b. Add fuel stabilizer to fuel tank. c. <i>Run pressure washer with high pressure hose</i> at least 5 minutes after adding stabilizer to allow it to enter the fuel system. d. Shut off engine

Storage

	<ol style="list-style-type: none"> 2. Lubricate cylinder and piston: <ol style="list-style-type: none"> a. Disconnect spark plug wire and remove spark plug b. Add one teaspoon oil through spark plug hole c. Place rag over spark plug hole and turn starter (or pull the recoil) a few times to lubricate the combustion chamber. d. Replace spark plug, but do not reconnect the spark plug wire.
<p>Prepare pressure washer for storage</p>	<p>Prepare the pressure washer for storage.</p> <ol style="list-style-type: none"> 1. Make sure the engine start switch is OFF and fuel valve is OFF. 2. Disconnect the engine spark plug wire if you haven't already done so. 3. Disconnect the high-pressure hose, garden hose, and spray gun.
<p>Move pressure washer to storage location</p>	<p>Let engine cool for 5 minutes before moving the pressure washer to its storage location.</p>

Burner Adjustment

OIL BURNER ADJUSTMENT (ONLY NEEDED IF WHITE EXHAUST SMOKE APPEARS)

The oil burner is preset, and performance tested at the factory (elevation 1100 feet). Different altitudes may require a one-time initial burner adjustment.

CAUTION:

If white smoke appears from the burner exhaust vent during start-up or operation, discontinue use and readjust air bands.

Specific steps for burner correction are given below.

Burner Correction

Adjusting the burner will require you to access the burner of the pressure washer while someone else is operating the spray gun.

Detailed instructions:

1. Locate the Air intake adjustment cover on blower housing (fig06839) below. Observe the position of the arrow on the cover relative to the calibration numbers. (0 is fully closed and 10 is fully open).
2. Make sure burner is cool to the touch before attempting adjustments.
3. Begin operation of the pressure washer and switch on the burner, as instructed in the operation section of the manual. Have someone operate the spray gun so the burner ignites.

(Note: Typical factory calibration is between 6-8).

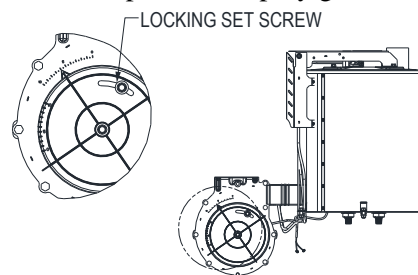

Fig. 06839

4. Locate and loosen the locking setscrew (fig06839) and rotate the cover clockwise (close) until either of following happens: black smoke appears from the burner exhaust vent or a rumbling sound is heard. Note: which number the arrow is near.
5. Slowly rotate air intake cover counterclockwise (open) until white smoke just starts to appear. Note: If no white smoke appears use fully opened calibration number for reference point.
6. Turn lever halfway back to the black smoke/rumbling sound position previously noted. Tighten the locking set screw.
7. Trigger gun on for 15 seconds and off for 5 seconds. Repeat this cycle 5-10 times. If not large puffs of white smoke are observed inlet air intake adjustment is complete. If large puffs of white smoke are observed on any re-ignitions this could be a sign that the air intake is opened to wide and will need further adjustment.
8. If large puffs of white smoke were observed in step 7, close air intake cover by half a calibration number. (example if calibration number is set to 5 then close intake cover to 4.5)
9. Repeat step 7 & 8 until unit re-ignites without large puffs of white smoke.

Maintenance & Repair

Inspect and maintain your pressure washer as specified below in order to keep it in safe and optimal working order. Follow all safety rules and recommended maintenance instructions.

WARNING

ALWAYS shut off water supply, bleed water pressure, turn off engine and disconnect the spark plug before cleaning, adjusting, or servicing the pressure washer. After servicing, make sure all guards and cover shields are replaced before using.

MAINTENANCE SCHEDULE

Item	Frequency
Remove dust/debris accumulation	As needed
Inspect fuel system	Each use
Inspect spray system	Each use
Clean inlet filter	Each use
Check tire pressure	Each use
Perform engine maintenance	As specified in Engine Owner's manual
Change pump oil	<ul style="list-style-type: none"> • Each use • After first 40 hours of use • Every 3 months or 500 hours of use after that
Maintain burner's fuel filter / water separator	<ul style="list-style-type: none"> • Drain water as needed • Change filter after every 500 hours of use
Descale coil	Annually, or more frequently as use and performance require (see Descale Heating Coil in this section for instructions).
Inspect and desoot coil if needed	Annually
Inspect/clean electrodes	Annually
Ignition coil	As needed
Check/tighten belts	Check belt tension after first 24 hours of use, then routinely with each oil change. Tighten or change belts as needed.

See detailed instructions for each maintenance item below.

(Note: For end-of-the-season storage instructions, see the "Storage" section of this manual.)

Maintenance & Repair

MAINTENANCE & REPAIR-DETAILED INSTRUCTIONS	
Follow safety rules	<p>Read and follow these safety rules whenever you will be servicing the pressure washer:</p> <ul style="list-style-type: none"> • Turn off / relieve pressure first. Always turn off pressure washer and relieve system pressure before inspection or maintenance. Remove spark plug or spark plug wire to prevent accidental starting. • Fuel valve off. Turn fuel shut-off valve to OFF position before transporting or servicing the pressure washer. • Replace guards. Make sure all guards and cover shields are replaced after servicing the pressure washer. • Major repair. Major service, including the installation or replacement of parts, should be performed only by a qualified electrical service technician. Obtain factory-approved parts from NorthStar Product Support at 1-800-270-0810. • Replacement parts. If a part needs replacement, only use factory approved repair parts. Replacement parts that do not meet specifications may result in a safety hazard or poor operation of the pressure washer and will void the warranty.
Keep pressure washer clean	<p>Keep pressure washer clean. If dust or debris accumulates on the pressure washer, clean the pressure washer with a damp cloth or soft bristle brush. Do not allow air intakes to become blocked.</p> <p style="text-align: center;">CAUTION: Do not spray pressure washer with a garden hose or pressure washer. Water may enter the pressure washer and cause damage.</p>
Inspect fuel system(s)	<p>Inspect the fuel systems (of both engine and burner) and check for leaks before each use. Do not start pressure washer until all needed repairs have been completed.</p> <p style="text-align: center;">⚠ WARNING: Fuel leak hazard Gasoline and burner fuel are highly explosive and fuel leaks can result in fire or explosions. You can be burned and seriously injured if the fuel system is not properly hooked up or there is a fuel leak when you start the engine.</p> <p>Inspect the entire fuel system, for both engine and burner. Look for:</p> <ul style="list-style-type: none"> • signs of leaks or deterioration, • chafed or spongy fuel hose, • loose connections, • loose or missing fuel hose clamps, • damaged fuel tank, or • defective gasoline shut-off valve.
Inspect spray system	<p>Inspect spray system for damage and leaks before each use. Do not start pressure washer until all needed repairs have been completed.</p> <p style="text-align: center;">⚠ WARNING: High pressure fluid injection hazard</p>

Maintenance & Repair

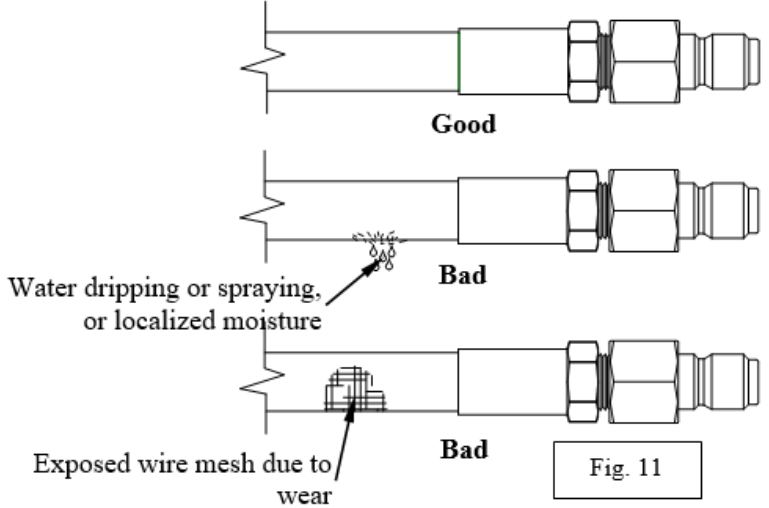
	<p>High-pressure fluid discharge from leaks (even pin-sized) or ruptured components can pierce skin and inject fluid into the body. Injection injury can result in blood poisoning and/or severe tissue damage leading to infection, gangrene, and possibly amputation.</p> <ul style="list-style-type: none"> • Never use a finger or skin to check for leaks. • Never operate machine with damaged or missing hoses/parts. • Never attempt to repair a high-pressure hose or component – Always replace it with a part that is rated at or above the pressure rating of this machine. <ol style="list-style-type: none"> 1) Check hoses, fittings, wand, trigger gun and connections for signs of wear, cracks, looseness, or leaks. Replace as required. 2) Check and clean the nozzle orifice.  <p style="text-align: right;">Fig. 11</p>
<p>Garden hose water inlet</p>	<p>Clean the garden hose water inlet filter before each use.</p> <p>⚠ WARNING: When cleaning filters, check whether dangerous chemicals have been used with the filter and take any precautions that may be recommended by the manufacturer of these chemicals. Always dispose of hazardous fluids per local, state, and national guidelines.</p> <ol style="list-style-type: none"> 1) Unscrew garden hose from water inlet (if connected). 2) Remove filter screen from garden hose water inlet. 3) Run water through filter screen to clean. 4) Reassemble
<p>Check tire pressure</p>	<p>Check and refill tire pressure before each use.</p> <ol style="list-style-type: none"> 1) Remove air cap on tire. 2) Check tire pressure. 3) If needed, fill tire to 30 psi. Do not over inflate. 4) Replace air cap.

Maintenance & Repair

Perform engine maintenance	Perform engine maintenance as specified in the engine owner's manual. Engine maintenance items include: <ol style="list-style-type: none">1. Changing oil and oil filter2. Air filter check/replacement3. Spark plug cleaning and replacement4. Fuel filter check/replacement5. Inspecting and cleaning muffler (and spark arrestor if equipped)
Change pump oil	Change the pump oil after the first 40 hours of use, and then after every 3 months or 500 hours of use after that. <ol style="list-style-type: none">1. Remove drain plug from pump.2. Drain pump oil into suitable container and dispose of responsibly.3. Reinstall oil drain plug.4. Make sure unit is sitting level. Fill pump with 18oz. of SAE30 non-detergent oil or Cat Pump Oil Item #22158 to middle of sight glass.5. Replace oil fill cap.  <p>The diagram shows a side view of a pump assembly. It features an oil cap on top, an oil sight glass on the side, a drain plug at the bottom, and a drain hose connected to the plug. Arrows point from the text labels to the corresponding parts of the pump.</p>

Fig157115_14

Maintenance & Repair

Maintain burner's fuel filter/water separator

Drain water from burner's filter bowl as needed and replace filter after every 500 hours of use or as needed.

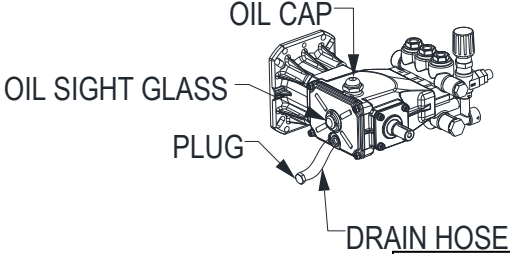
- 1) After each use of the burner, visually check the filter bowl. If any water has accumulated, drain it via the water drain at the bottom of the bowl.
- 2) After every 500 hours of operation, empty the burner's fuel tank in order to remove the filter bowl and inspect the fuel filter/water separator. Replace filter as needed.

Important: Always drain the diesel fuel tank before removing the filter drain.

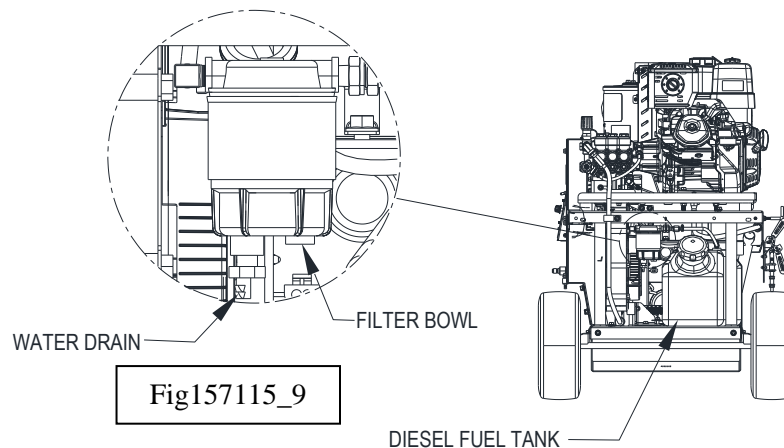

Descal heating coil

Descal coil tubing annually or more frequently as needed.

If pressure washer is used where the water source contains a high mineral content, or is considered "Hard Water", scale can build up inside the heating coil tubing. Scale deposits will decrease the performance of pressure washer by reducing both water flow and water pressure. The use of a water softener and an additional strainer may be needed in areas that have high mineral content in the water supply. More frequent descaling may be required if higher temperatures or steam mode is used regularly. Descal the coil tubing more frequently if you detect a decrease in pressure or temperature.

Choose a well-ventilated area and use the recommended PPE (personal protective equipment) of the coil cleaning chemical manufacture when descaling the coil and/or using coil cleaning chemicals. This may include, but is not limited to:

- Rubber gloves
- Goggles
- Apron

Required supplies:

- 1) Coil cleaner
- 2) 5-gallon bucket
- 3) Circulating pump
- 4) Supply hose A
- 5) Supply hose B
- 6) Return hose
- 7) Hose barb fittings, if applicable
- 8) Hose clamps, if applicable

Maintenance & Repair

⚠ WARNING

SCALE BUILD-UP/EXPLOSION HAZARD

- Failure to properly maintain the coil can result in a steam explosion.
- Scale or lime build-up will act as an insulator and decrease coil efficiency.
- Weakening of the coil tube due to hot spots can result in a coil rupture.

CHEMICAL EXPOSURE HAZARD

- Always wear properly rated safety goggles when descaling the coil.
- Always wear rubber gloves when handling coil cleaning chemical.
- Understand all safety hazards and first aid measures for coil cleaning chemical being used.
- Follow coil cleaning chemical manufacturer's directions when handling, mixing and using coil cleaning chemical.

Read owner's manual. See maintenance section of manual for descaling procedure.

Read the coil cleaning chemical safety information.

Serious injury or death can result if safety instructions are not followed.

To descale the coil:

- 1) Remove the outlet coil quick connect nipple fitting from the coil outlet.
- 2) Remove the inlet coil swivel fitting from the coil inlet.

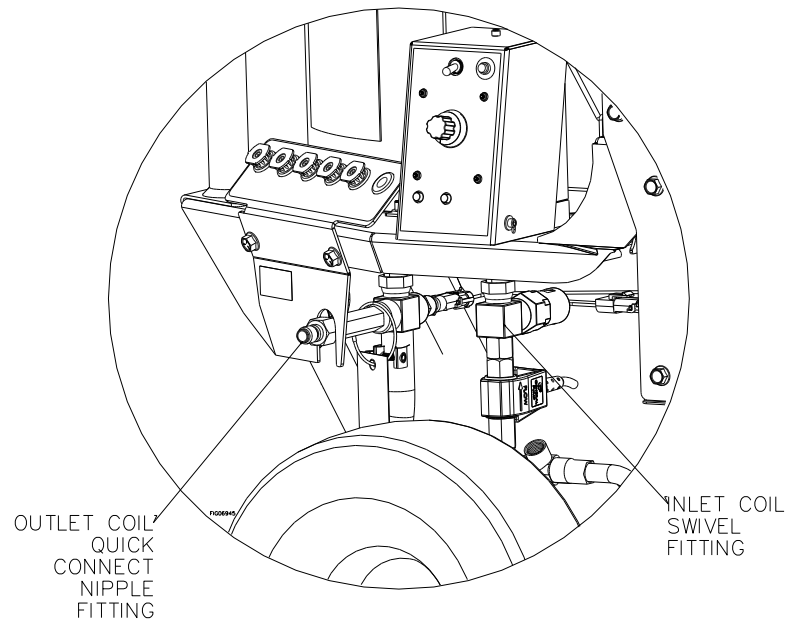

- 3) Connect hose(s) as shown below to the coil inlet, coil outlet and the circulating pump. Do not hook up the pressure washer hose or gun.
- 4) Add commercial coil cleaner to water and mix. Use an acid resistant 5-gallon bucket.
- 5) Place the remaining end of the Return Hose into the 5-gallon bucket.
- 6) Place the remaining end of the Supply Hose B into the 5-gallon bucket. We recommend using an inlet filter screen on Supply Hose B.
- 7) Connect the power supply to the circulating pump.
- 8) Turn on the circulating pump to begin circulating the coil cleaning solution.
- 9) Run the circulating pump for 1 to 3 hours (follow coil cleaner manufacturing instructions), recirculating the coil cleaning solution. **CAUTION:** Do not run the pressure washer or the burner.

Maintenance & Repair

- 10) Dispose of the cleaning solution where it is not harmful to animals or the environment. Follow the coil cleaner manufacturers disposal instructions.
- 11) Fill the 5-gallon bucket with fresh water.
- 12) Place the end of Return Hose back into the 5-gallon bucket with fresh water.
- 13) Place the end of Supply Hose B back into the 5-gallon bucket with fresh water.
- 14) Turn on the circulating pump to begin circulating the fresh water.
- 15) Run the circulating pump for 5 minutes, recirculating the fresh water.
- 16) Repeat steps 11-15 at least 3 times to ensure all remaining coil cleaning residue has been flushed out with fresh water.
- 17) Reinstall the outlet coil quick connect nipple fitting to the coil outlet.
- 18) Reinstall the inlet coil swivel fitting to the coil inlet.
- 19) Attach the high-pressure hose(s) to the high-pressure outlet on the machine.
- 20) Flush with fresh water and clean the garden hose water inlet screen when finished.

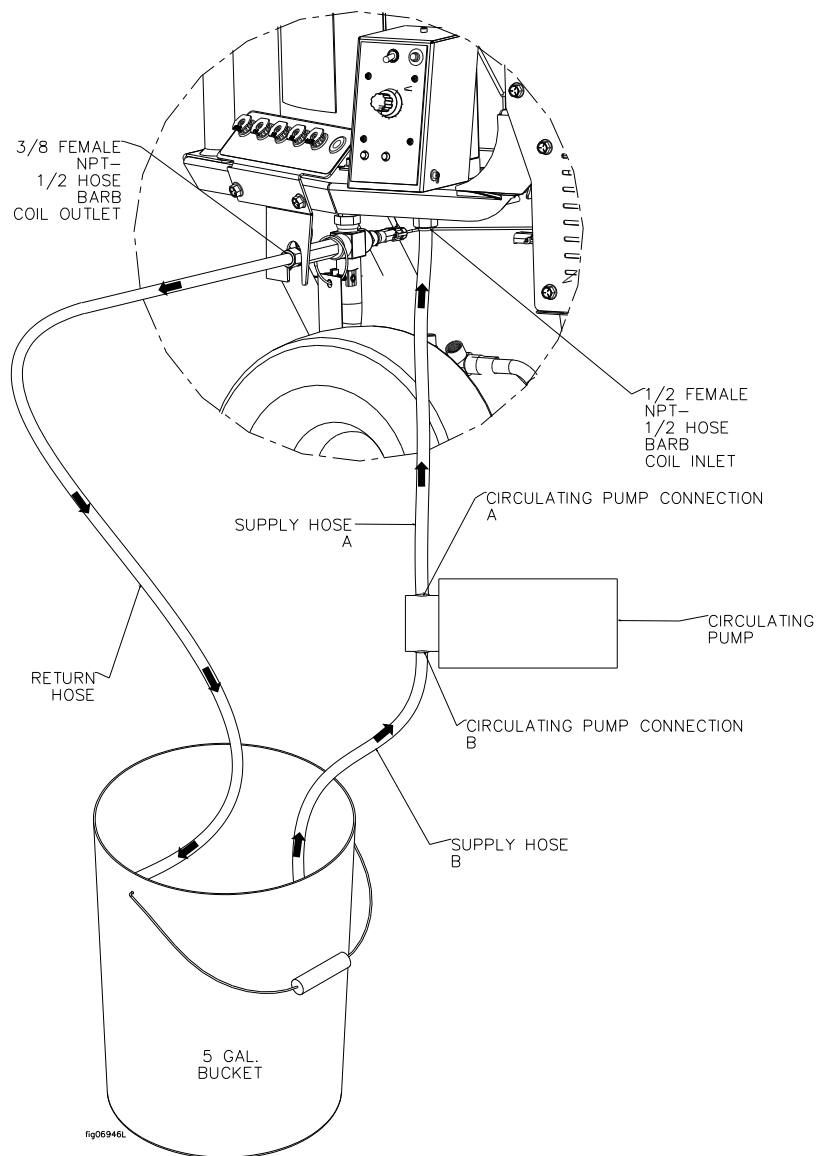

Maintenance & Repair

Cleaning Flow Switch

Inspect and clean the flow switch as needed

Mineral build-up and/or debris within the flow switch can occur and may affect burner operation if not periodically cleaned. Mineral build-up and/or debris can stop the movement of the shuttle inside the flow switch body. Shuttle movement is important because the burner will not fire if the shuttle does not move. The shuttle movement actuates a switch inside the flow switch housing which allows the burner to fire during spray mode.

- 1) Disconnect the swivel fitting from elbow to the inlet of the coil

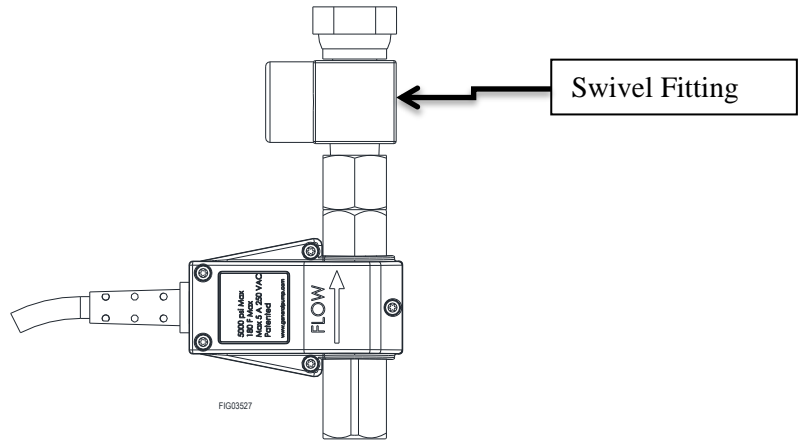

- 2) Remove the "Cap" fitting from the flow switch.

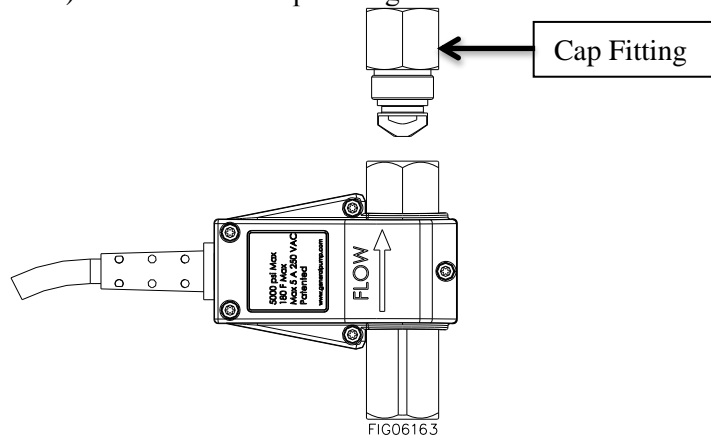

- 3) Slide out the "Shuttle Assembly". If the magnet in the shuttle assembly is damaged or missing, replace the entire flow switch assembly. To order a replacement flow switch assembly, call Northstar Product Support at **1-800-270-0810**.

Maintenance & Repair

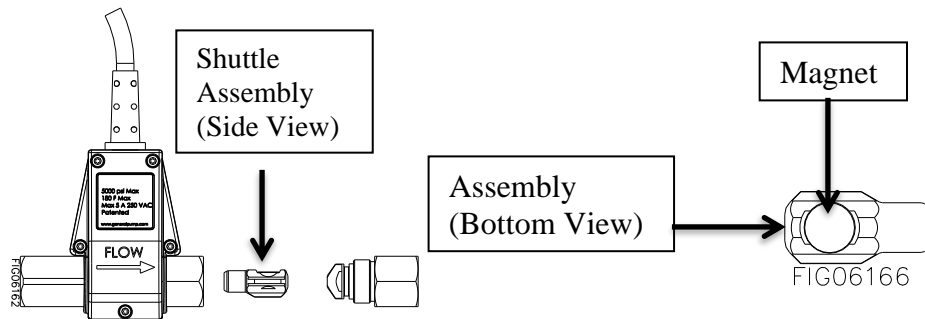

- 4) Observe the “Shuttle Assembly” and internal portion of “Body” for obstructions, hard water deposits and any other foreign debris. Remove the foreign debris with light scraping or compressed air. If no additional cleaning is required continue to Step 7. If additional cleaning is required continue to step 5.

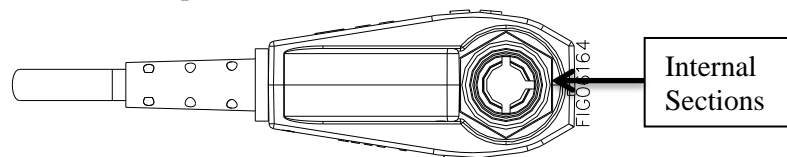

- 5) Remove the “Body” from the plastic “Enclosure” and soak the “Body” in CLR or similar solution to dislodge excess buildup. The screws (QTY 5) in the “Enclosure” are TORX T10.

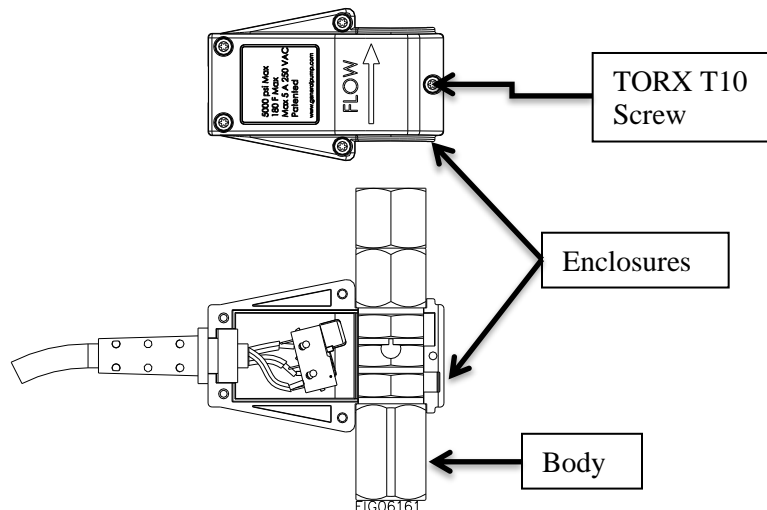

- 6) Rinse “Body”
- 7) When cleaning is complete reinstall the “Body” into the “Enclosures”, taking care not to cause damage. Tighten the “Screws” into the body until they are snug. Do not over-tighten the screws.
- 8) Insert the “Shuttle Assembly” with the rounded end first, into the body. Align with grooves.

Maintenance & Repair

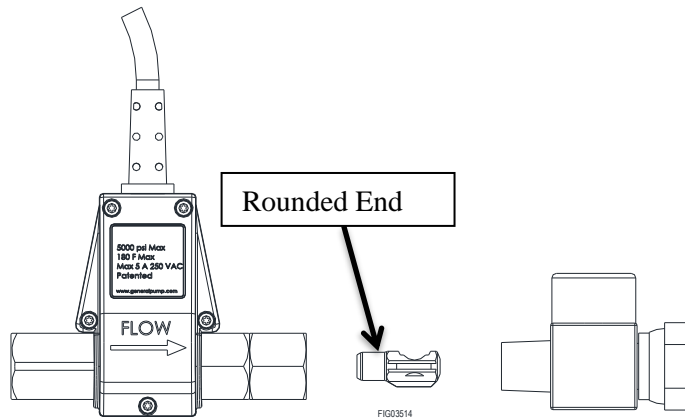
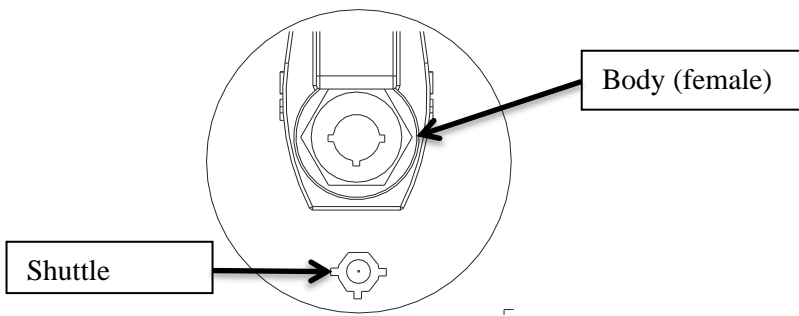

- 9) Inspect the O-ring on the “Cap”, if it is damaged, replace the entire flow switch assembly. To order a replacement flow switch assembly, call Northstar Product Support at **1-800-270-0810**. If the O-ring is not damaged, re-install the “Cap” onto the “Body”. Torque the cap to 100lb-in.

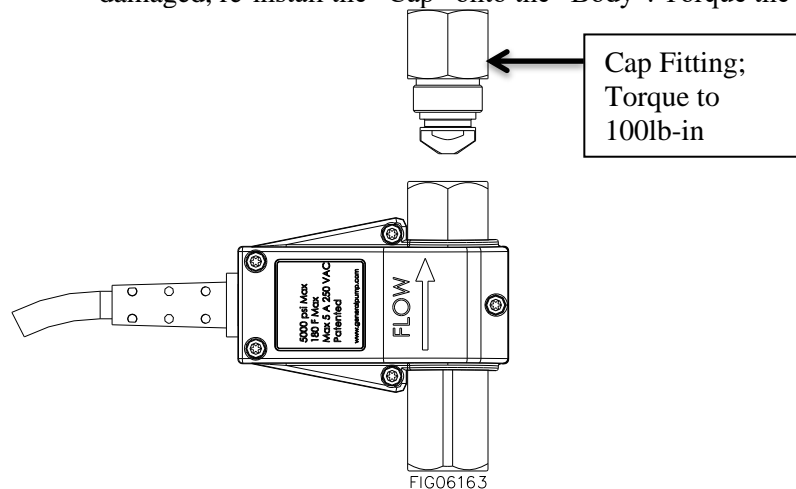

- 10) On the elbow on the inlet of the coil, remove any remaining thread tape/sealant. Re-apply new thread tape/sealant on the elbow. Re-connect the swivel to the elbow. Hand-tighten the swivel onto the elbow, and once snug, using a wrench continue to tighten the swivel two additional revolutions.

Maintenance & Repair

Inspect heating coil and desoot as needed

Inspect and desoot coil annually.

Most coils never require desooting. However, poor grades of fuel oil or inadequate combustion air will cause heavy soot build-up on the outside surface of the heating coil tubing. These deposits will insulate the coil, which then restricts air flow through the heat exchanger and further aggravates the soot build-up. Be sure to wipe the sight glass. See Fig06172 on next page.

If soot has built up on the exterior of the coil tubing, clean as follows:

- 1) Wear protective clothing, goggles, and gloves.
- 2) Disconnect Fuel line from outer cover. Disconnect Flame sensor and High Tension Leads from black box bolted to the guard on side of Outer Wrap.
- 3) Remove (4) 5/16" Bolts from Outer Cover.
- 4) Remove Outer Cover set aside.
- 5) Remove (4) 5/16" bolts and nuts off the hold down brackets on the Outer Wrap.
- 6) Remove all inlet and outlet fittings.
- 7) Remove the (2) 1-1/4" Jam nuts and the 3/8" bolt underneath the base.
- 8) Lift off Outer Wrap, Inner Wrap and Inner Cover. Set aside.
- 9) Using a couple of straps, wrap them around the Coil and attach to a hoist to lift off. You may also use the lifting eyes with hooks to lift with hoist. This coil weighs at least 125 lbs. If no hoist is available, it is recommended that this become a 2-man job each with the ability to lift at least 65 lbs.
- 10) Clean the coil.
- 11) Reassemble the coil and lids to the machine. Make sure the white insulation remains in place.
- 12) Reattach high-pressure hose and thermostat and make sure all fittings are tight before using the machine.

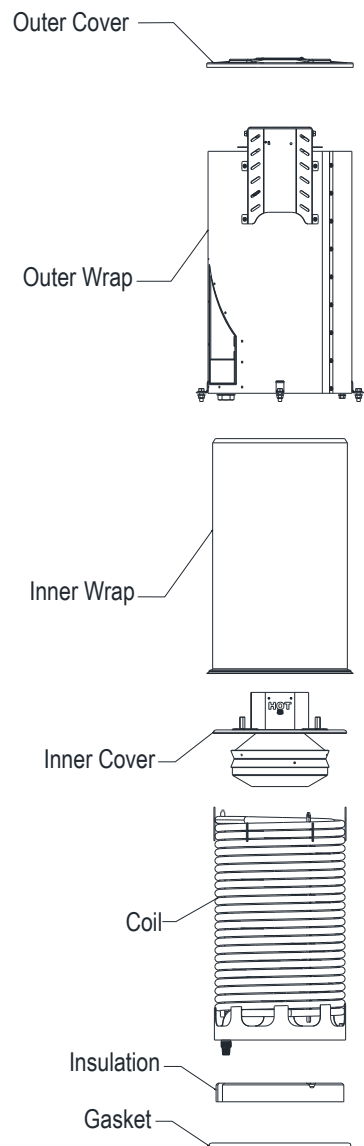

Fig06288

Maintenance & Repair

Inspect electrodes

Inspect electrodes yearly and replace as needed.

- 1) Loosen front (2) bolts using a 1/2" socket. Loosen side (2) bolts using a 1/2" socket and wrench.
- 2) Remove (3) screws using a 5/32" hex key Allen wrench from the combustion head. Lift off combustion head from outer cover.

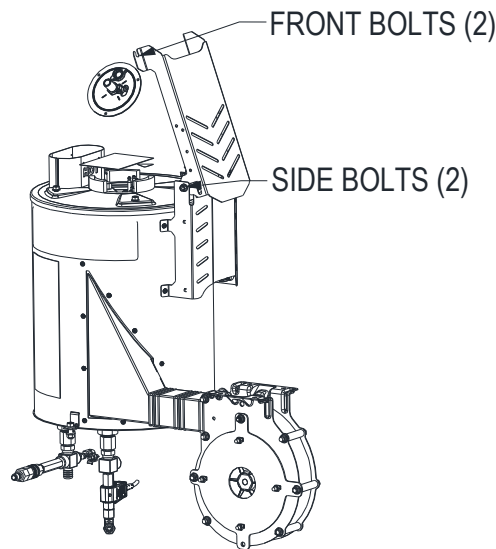

Fig06842

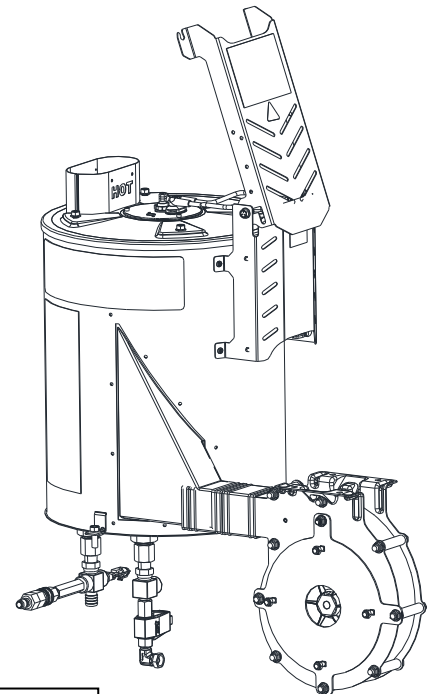

Fig06843

- 3) Disconnect flame sensor and electrode wires. Disconnect fuel line.
- 4) Clean off carbon deposits, which may have accumulated on the tips of the electrodes.
- 5) If electrodes are outside of manufacturing specification, Replace electrodes.

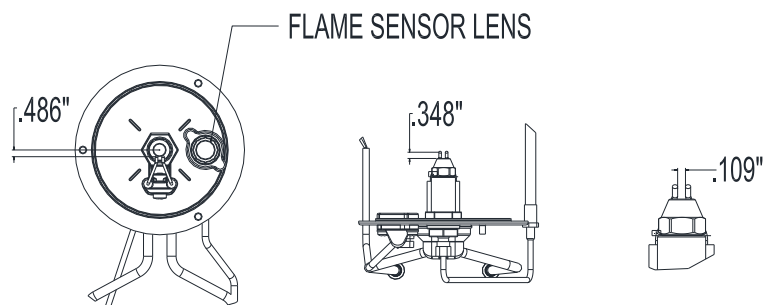
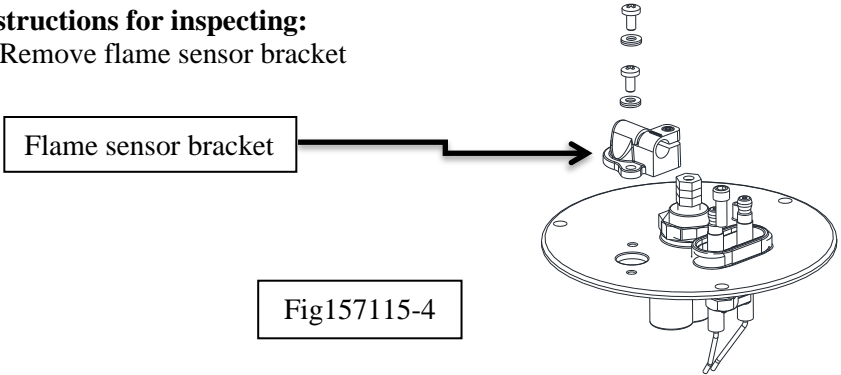

Fig06172

NOTICE: Wipe combustion head flame sensor lens every 100 hours. If the flame sensor lens gets sooted up the flame sensor will be unable to sense a flame and therefore the burner will not fire. Do not contaminate or touch the fuel nozzle tip.

Maintenance & Repair

	<p>Instructions for inspecting:</p> <ol style="list-style-type: none"> 1) Remove flame sensor bracket <div style="text-align: center;">  </div> <ol style="list-style-type: none"> 2) Following normal starting procedure with burner and thermostat off. With unit running look through flame sensor sight glass to observe if there is a spark
<p>Ignition coil</p>	<p>Instructions for setting Gap:</p> <ol style="list-style-type: none"> 1) Disconnect engine spark plug wire. 2) Remove Belt guard. 3) Check gap between pickup arm and magnet to determine if adjustment is needed. 4) If adjustment is needed loosen mount bolts using 9/64 allen wrench. 5) Place a .01" non-magnetic feeler gauge between the ignition coil pickup arm and flywheel to set the air gap. (you may need to partially tighten mount bolts so ignition coil holds its position when setting gap.) 6) Re-tighten mount bolts, torque to 19.5 in-lbs 7) Recheck gap. repeat steps 5 & 6 if needed 8) Slowly pull recoil to rotate flywheel a few revolutions and confirm clearance with flywheel and magnet 9) Replace Guarding and reconnect spark plug.
<p>Air, Fuel, Ignition System Drive belt maintenance</p>	<p>Check drive belt tension after first 24 hours of running and then routinely with each oil change. Tighten or replace belt as needed. Always tighten belt if slipping.</p> <p>⚠ WARNING: Belt slippage can cause static electricity build-up, which may result in sparking. Fire ignition can result.</p> <p><u>Instructions:</u></p> <ol style="list-style-type: none"> 1) Make sure engine is off and spark plug wire is removed. 2) Remove belt guard. See "Parts Breakdown" section of this manual for location. 3) Inspect belt for wear/damage. Replace as needed. 4) Loosen Tension Bracket mounting bolts (3) and lower Fuel Pump mount bolt (1) just enough to allow tension bracket to slide. See Figure A & B. 5) To tension the belt, tighten the tension nut shown in Figure C. This will slide the tension bracket toward heat exchanger and tighten the belt. The Air, Fuel, Ignition drive system requires very little tension to perform optimally, Do not over tension. Typically, an 1/8 inch of adjustment is adequate for re-tensioning a belt that was slipping. See further guidelines Below.

Maintenance & Repair

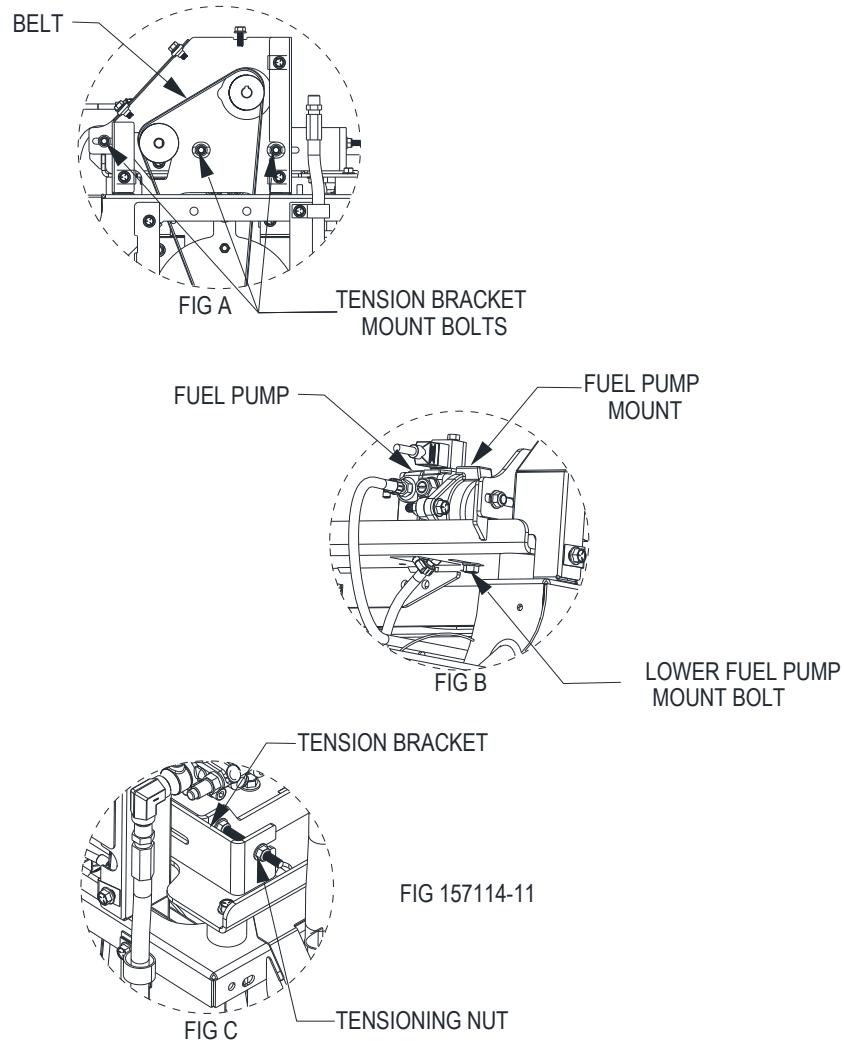

Note: Some general rules of belt tension are:

- The ideal tension is the lowest tension without belt slippage
- Over tightening decreases belt and bearing life.
- Keep belts clean and free of foreign material that may cause slippage
- Do not apply belt dressing, which can cause damage and early belt failure.

- 6) Re-tighten Tension Bracket mounting bolts (3) and Lower fuel pump mount bolt (1).
- 7) Replace belt guard.

⚠ WARNING:

Do not operate unless belt guard is in place to prevent access to rotating parts. Clothing or hair can become rapidly entangled in unguarded rotating parts, resulting in serious injury or death.

NOTE: TO COMMERCIAL USERS:

All mechanical equipment, no matter how well designed, will need maintenance and repairs. A NorthStar pressure washer is no exception. At times, a NorthStar pressure washer may become inoperable because repairs are required.

Maintenance & Repair

NorthStar Product Support will assist in these repairs as needed, but if an inoperable pressure washer creates a major expense to your business, then we strongly recommend the following:

- Have a staff person become familiar with the mechanical operation of the pressure washer and capable of making minor repairs and performing all preventative maintenance procedures.
- Keep a stock of recommended service parts for maintenance and minor repairs.

IMPORTANT:

If a part needs replacement, only use parts that meet the manufacturer's part number specifications. Replacement parts that do not meet specifications may result in a safety hazard or poor operation of the pressure washer.

**Contact NorthStar Product Support at 1-800-270-0810
for any questions, problems, or parts orders.**

Troubleshooting

ENGINE WILL NOT START

<i>Causes</i>	<i>Solutions</i>
Low Oil Shutdown	Fill engine with the adequate amount of oil.
Cold Engine	Choke engine to start.
No Fuel	Add gas to engine; make sure fuel shutoff valve is open.
Spark plug wire not attached	Attach spark plug wire to spark plug.

PRESSURE WASHER RUNS BUT BURNER DOESN'T FIRE

<i>Causes</i>	<i>Solutions</i>
Air	
Belt for Air fuel delivery system is broke or slipping	Replace or tighten belt.
Air intake is blocked or restricted	Inspect & remove any blockages
Air leaking	Inspect rubber boot and connections between the heat exchanger and blower for leaks. Replace boot or tighten connections
Improper air adjustment	See Burner adjustment section of manual
Fuel	
Fuel tank empty	Fill fuel tank with kerosene, diesel or fuel oil.
Fuel filter water separator is clogged or full of water	Drain or replace if needed
Clogged fuel nozzle	Replace
Fuel pump malfunctioning	Fuel solenoid, coupler, or pump itself may need to be replaced. Contact product support.
	Check fuel pressure and replace if needed
Ignition	
Electrodes damaged or worn	Clean, adjust, or replace electrodes. See maintenance and repair section of manual.
Ignition coil failure or improperly gapped	see maintenance and repair section or contact product support
Other	
Heat switch turned OFF	Turn heat switch ON.
Thermostat set too low or off	Set thermostat to desired temp.
Trigger gun is not open	Open Trigger gun to allow flow
Flow switch failed or clogged	Clean or replace flow switch. See Maintenance and repair section of manual
Primary control board malfunctioning	Call Product Support.
Flame sensor	Call Product Support

PRESSURE WASHER RUNS BUT NO PRESSURE

<i>Causes</i>	<i>Solutions</i>
Partially clogged or damaged nozzle	Clean or replace nozzle.
Low water flow	Make sure the water supply is more than 4.8 gpm.
Clogged inlet filter	Clean or replace inlet filter
Easy start valve is stuck open	Clean or replace
Damage or obstructed Pump valves	Clean or replace
Worn pump packings	Replace pump packings
Unloader not working properly	Repair or replace

Troubleshooting

PRESSURE WASHER SURGES OR CYCLES WHILE IN BYPASS

<i>Causes</i>	<i>Solutions</i>
Leak between unloader and gun.	Check all connections between unloader and gun for leaks. Tighten loose components and replace damaged components.
Gun leaking internally	Replace spray gun.

SMOKE FROM HEAT EXCHANGER

<i>Causes</i>	<i>Solutions</i>
Engine not at full throttle	Throttle engine all the way up.
Damper not adjusted properly	Adjust the damper until the burner burns cleanly. See <i>Burner Adjustment</i> .
Poor quality fuel	Use kerosene for the cleanest burn.
Belt broken	Replace belt.

WATER NOT HEATING SUFFICIENTLY

<i>Causes</i>	<i>Solutions</i>
Scale build-up in coil	See <i>Coil Descaling</i> under <i>Maintenance Instructions</i> .
Coil is full of soot	See <i>Coil Desooting</i> under <i>Maintenance Instructions</i> .

POOR OR NO DETERGENT SUPPLY

<i>Causes</i>	<i>Solutions</i>
Inadequate detergent supply	Refill detergent container. Make sure chemical strainer is fully submerged.
High pressure hose too long	Use less hose. Move machine closer to the work.
Chemical strainer or injector clogged	Clean the strainer and injector. Always start with a clean detergent container. Run clean water through the injector after each use.

Major Components

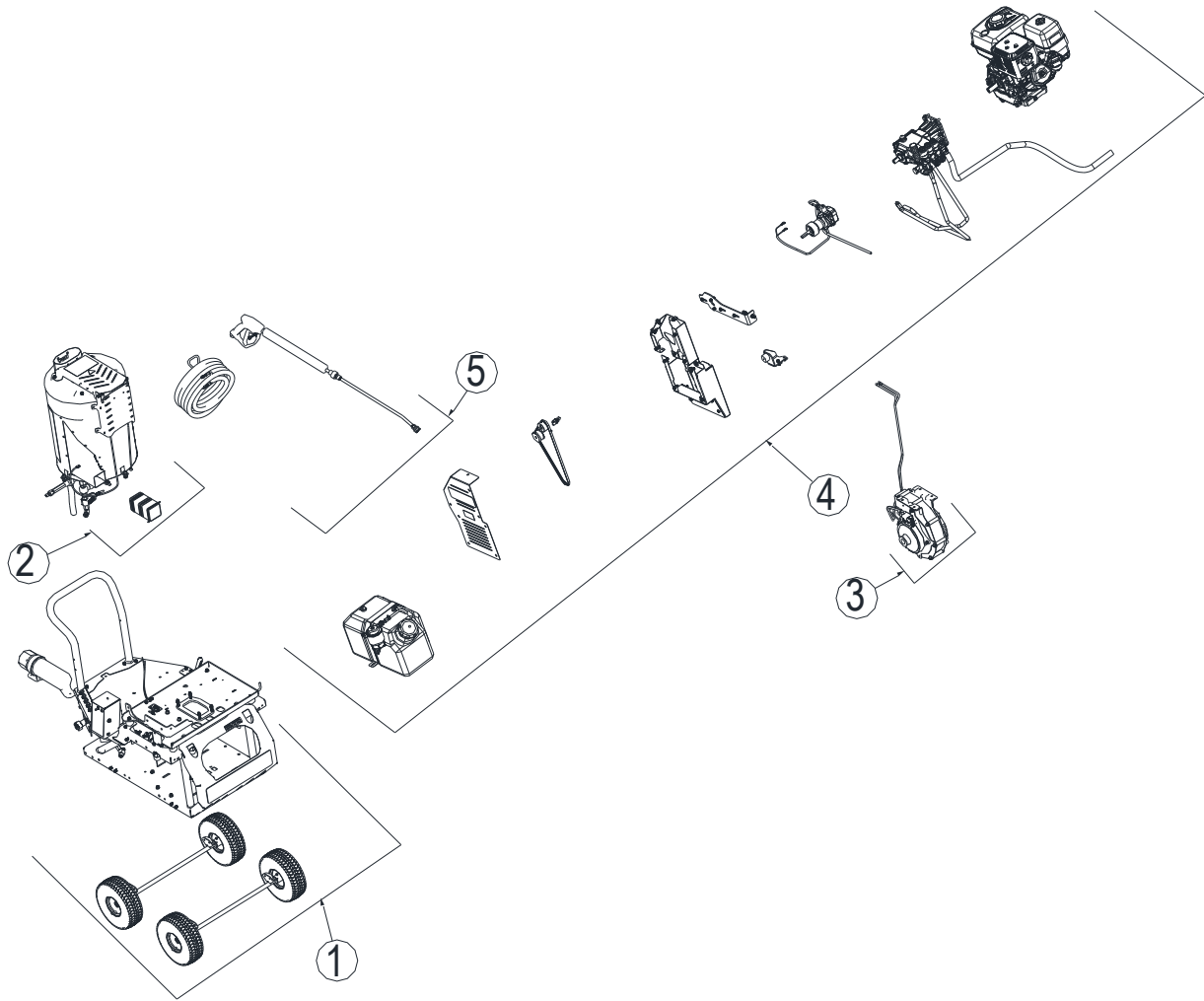

Fig157115_11

MAJOR COMPONENTS		
Ref.#	Description	Page#
1	Frame	51
2	Heat Exchanger	55
3	Blower and ignition flywheel	57
4	Engine, Water pump, Fuel pump and drive parts	59
5	Accessories- Gun, hose, chemical injector	62
These components go into more detail on the following pages.		

Parts Explosion: Frame – Rev N

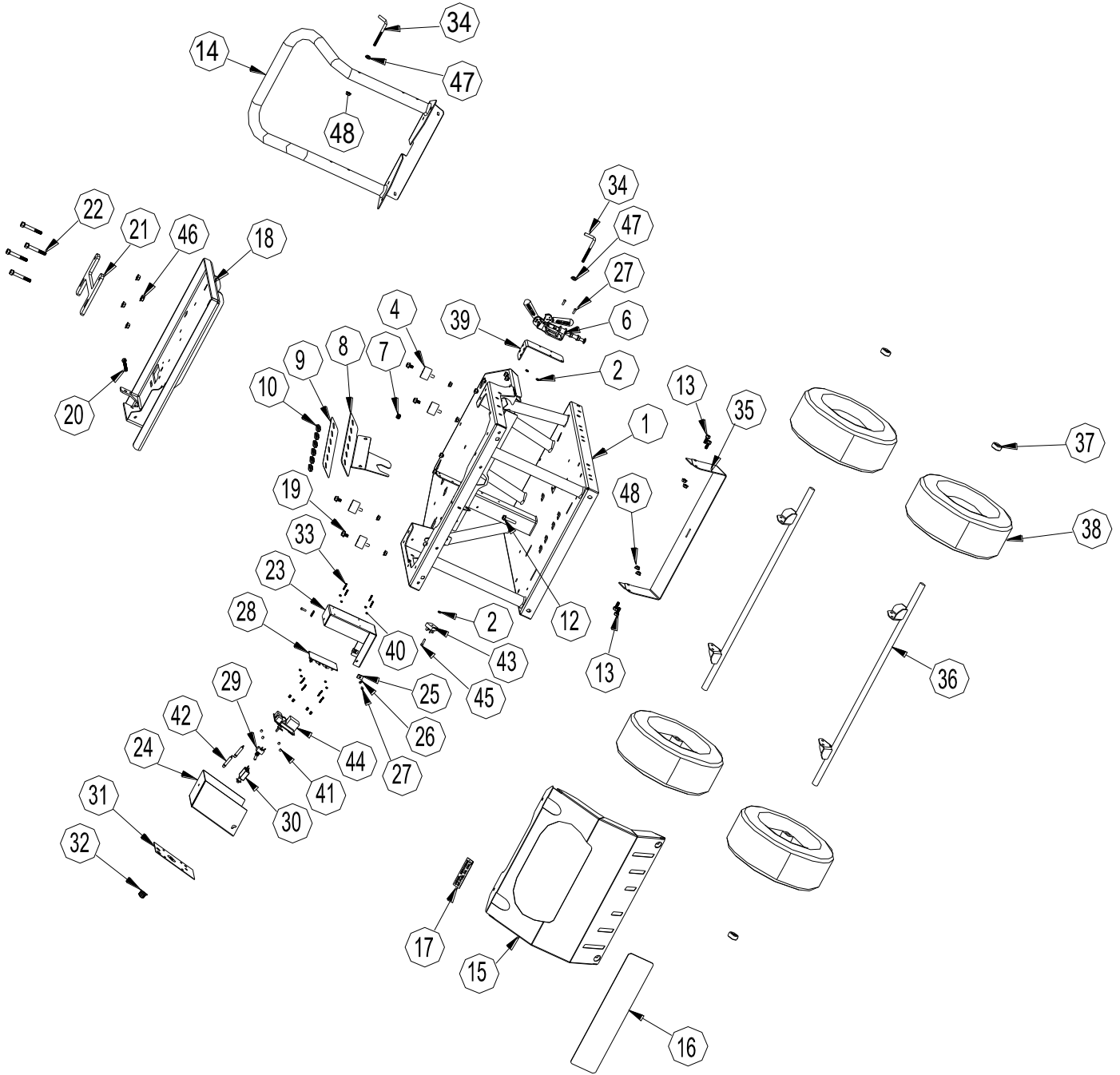

Fig157115_12L

Parts Explosion: Frame – Rev N

<i>ITEM</i>	<i>PART#</i>	<i>DESCRIPTION</i>	<i>QTY</i>
1	799967	CORE WELDMENT	1
2	82008	NUT, 10-32 KEPS	3
4	800619	ISO MOUNT	4
6	799875	BRAKE	1
7	777838	HEX PLUG, 1/4" C.SUNK	1
8	803916	PLATE, NOZZLE HOLDER	1
9	800663	DECAL, NOZZLE OPTIONS	1
10	777111	GROMMET,7/16 ID-.125	6
12	82017	BOLT,5/16-18 X 1.5 HHSF BOLT GR5	1
13	82621	5/16-18 X .75 HHFB	33
14	800080	HANDLE WELDMENT	1
15	800483	BUMPER	1
16	788999	LABEL, AC NORTHSTAR, NARROW	1
17	801056	DECAL, DIESEL ONLY SMALL	1
18	801440	ENGINE FAN PLATE WELDMENT	1
19	82014	5/16"-18 X 1/2" HHSF BOLT	4
20	82096	BOLT, 5/16"-18 X 3.5" HHFB	1
21	800556	PLATE, ENGINE RISER	1
22	82626	BOLT, 3/8"-16 X 2.5" HHFB	4
23	800044	CONTROL BOX BASE	1
24	800062	CONTROL BOX COVER	1
25	82067	CLIP NUT, 10-32	3
26	82068	WASHER, NO 10 FLAT	2
27	82006	BOLT, #10-32 X 1/2" SHCS	5
28	792287	PRIMARY CONTROL BOARD, 12VDC	1
29	777855	SWITCH, TOGGLE	1
30	802307	BREAKER, CIRCUIT, 5 AMP	1
31	800978	DECAL, OP CONTROL BOX	1
32	797052	THERMOSTAT KNOB	1
33	87435	BOLT, 4-40 x 3/4" PHIL PAN ZN	8
34	38509	HOOK, THREADED GUN	2
35	800595	TIP BRACKET	1
36	800432	WELDMENT, AXLE 30"	2
37	305200	RETAINER, WHEEL - PW, TE	4
38	778295	TIRE, TURF	4
39	800593	BRAKE MOUNT	1
40	87961	4-40 NYLON INSERT LOCK NUT	16
41	800186	SPACER, NYLON #4	8

Parts Explosion: Frame – Rev N

<i>ITEM</i>	<i>PART#</i>	<i>DESCRIPTION</i>	<i>QTY</i>
42	777646	LED, RED 12VDC	2
43	799931	RECTIFIER	1
44	802972	CONTROLLER, TEMP. ASSEMBLY	1
45	82007	SCREW, 10-32 X 3/4" SHCS	1
46	82631	NUT, 3/8-16 HEX FLANGE NYLON	1
47	82019	NUT, 5/16-18 SER. FLANGE	2
48	82630	NUT, 5/16-18 FLANGE NYLOC	38

Parts Explosion: Heat Exchanger – Rev N

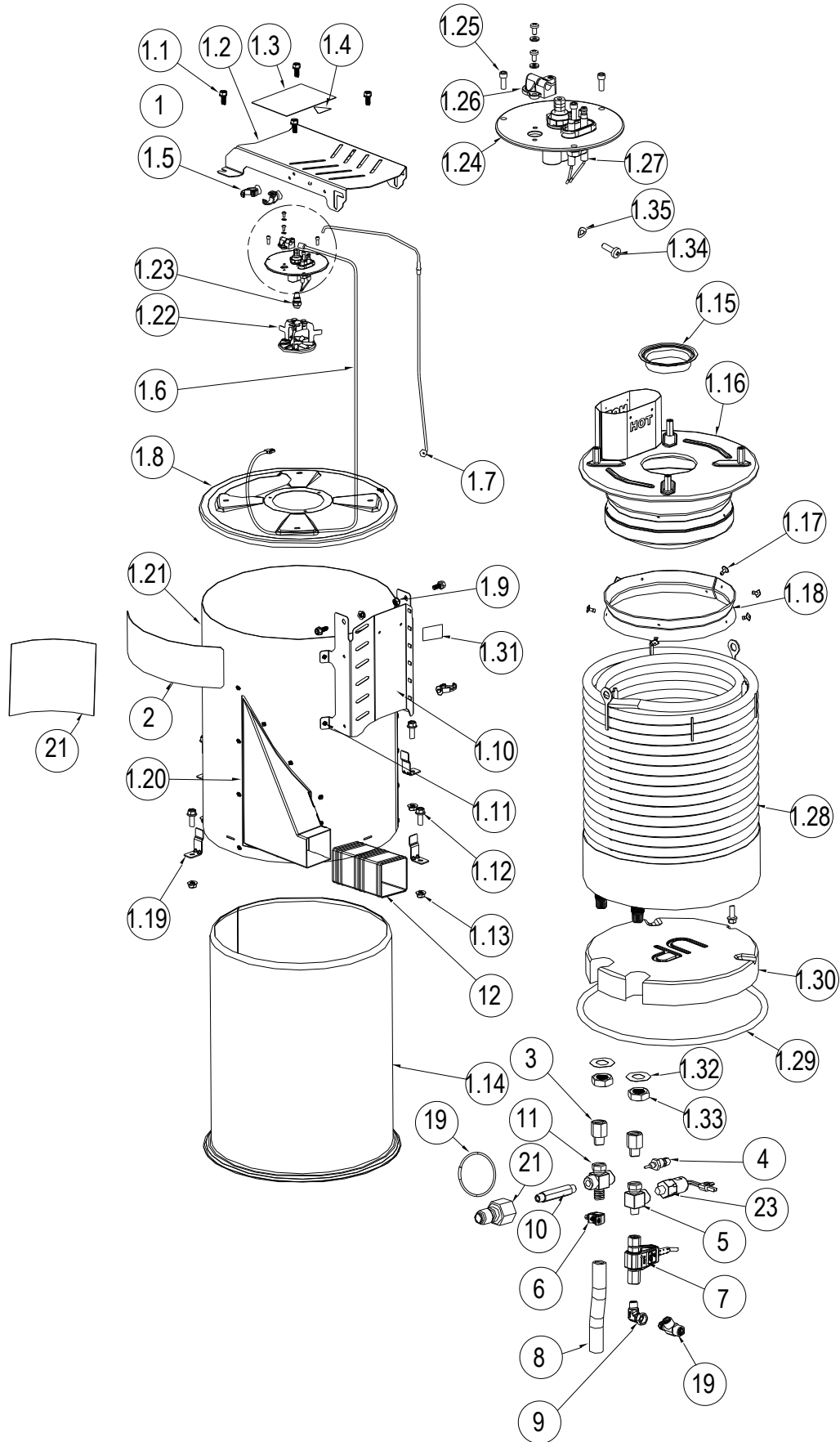
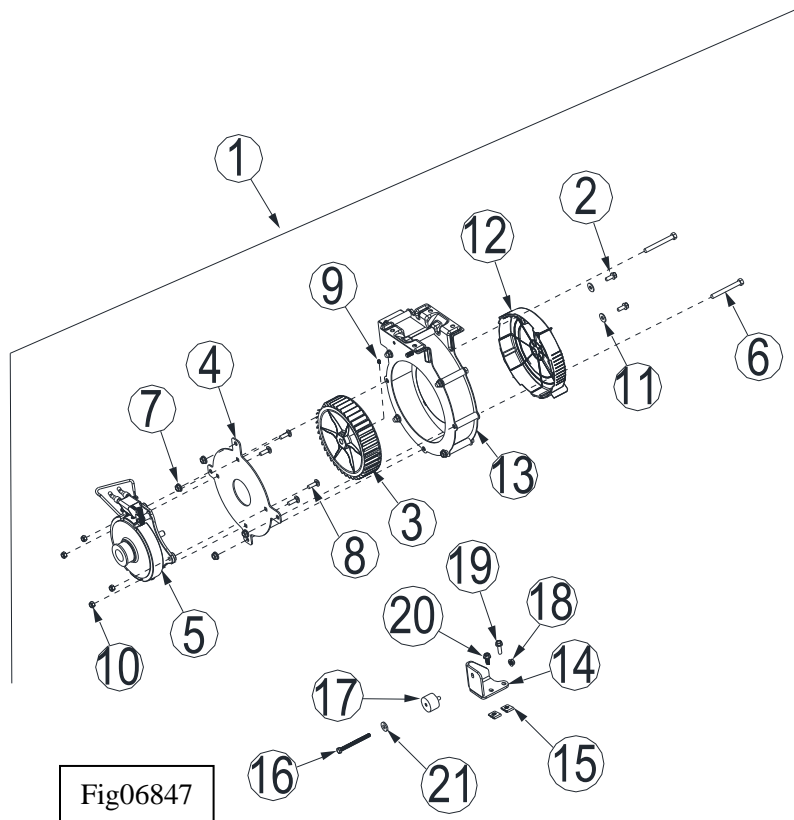

Fig06846

Parts Explosion: Blower & EMF – Rev N

ITEM	PART#	DESCRIPTION	QTY
1	N/A	Medium heat exchanger assembly	1
1.1	82621	Bolt, 5/16-18 x 3/4" hex head flange	6
1.2	797692	Fuel line guard, top	1
1.3	798383	Decal, Flame Sensor Lens Cleaning Instructions	1
1.4	796496	Decal, Electrical Shock Hazard	1
1.5	793645	Clip, hose/wire	14
1.6	800624	Flame sensor	1
1.7	803358	Fuel line	1
1.8	797663	Outer cover weldment, XL vent	1
1.9	82630	Nut, 5/16-18 nylon insert lock	2
1.10	797649	Fuel line guard, side	1
1.11	82649	Blind rivet, 3/16"	21
1.12	82624	Bolt, 3/8-16 x 1" hex head flange, Gr. 5	5
1.13	82631	Nut, 3/8-16 hex flange nylon	4
1.14	792131	Inner wrap,	1
1.15	795764	Ring, air jacket 98mm	1
1.16	798379	Inner cover weldment, XL 7" outlet	1
1.17	82660	Rivet, 3/16 large flange	6
1.18	792248	Gasket	1
1.19	792135	Hold down bracket	4
1.20	797466	Angled intake duct weldment	1
1.21	799830	Outer Wrap, MD, HX+ Painted	1
1.22	796314	Diffuser 9 FIN 3.5 INCH .	1
1.22.1	82005	Nut, 8-32 keps (not shown, sold separately)	1
1.22.2	82004	Bolt, 8-32 x 1/2" BHCS (not shown, sold separately)	1
1.23	799677	Fuel nozzle, 2.00 GPH 90B	1
1.24	803677	Combustion head assembly	1
1.25	82006	Screw, 10-32 x 1/2" button head cap	3
1.26	793595	Flame sensor bracket kit	1
1.27	799294	Electrodes, HX-5.5 GPM	1
1.28	791883	Coil weldment, 105ft	1
1.29	792224	Gasket	1
1.30	792223	Insulation, firebrick	1
1.31	797513	Decal burn hazard	1
1.32	82606	Washer, 1" ID x 2" OD copper	2
1.33	82605	Nut, 1"-14 jam	2
1.34	806326	Screw, M5-0.8 x 16MM PHMS	1
1.35	784489	Washer, M5 Wave	1
2	788999	Label, AC Northstar, narrow	1
3	779847	Adapter, 8MP-8FP - PW	2
4	793966	NTC Thermistor	1
5	799855	Fitting, coil inlet manifold	1
6	17141	Clamp, 3/4" hose	1
7	797121	Switch, flow 12.0 GPM 5000PSI-PW	1
8	800127	Hose, 3/4" rupture disk discharge	1
9	797199	Fitting, 3/8" MPTXSFT elbow	1
10	800096	High pressure 4" nipple	1
11	800126	Fitting, coil outlet manifold w/rupture disk	1
12	800779	Connector, straight rubber	1
19	32821	TFG Lanyard - GN	1
20	800661	Decal, Branding	1
21	777915	Nipple, QC 3/8, 3/8 FNPT-PW	1
23	793964	High pressure Limit Switch	1

Parts Explosion: Blower & EMF – Rev N



<i>ITEM</i>	<i>PART#</i>	<i>DESCRIPTION</i>	<i>QTY</i>
1	N/A	ASSEMBLY FAN & HUB STATOR	1
2	82015	5/16-18 X 3/4 HHSF BOLT	2
3	792268	FAN, 200MM X 47.5MM - PW	1
4	799845	STATOR ADAPTER PLATE, DC	1
5	799693	HUB STATOR ASSY	1
6	82109	3/8-16 X 3.25" HHCS GR5Z	2
7	82026	SERRATED FLANGE NUT	3
8	82090	CARRIAGE BOLT, 5/16 X 1"	4
9	82613	M6-1.0X8MM, SET SCREW KNURL-CUP	1
10	82020	NUT, 5/16-18 NYLON INSERT	4
11	788016	2 MM SPACER	2
12	801874	INLET DAMPER CAP, MEDIUM	1
13	801982	AC HOUSING ASSEMBLY W/ADJUSTABLE DAMPER	1
14	801658	PLATE, ISO MOUNT STIFFENER BRACKET	1
15	82720	CLIP NUT	2
16	82096	BOLT, 5/16"-18 X 3.5"	1
17	800619	MOUNT, ISO HWPG - 40 DURO	1
18	82630	5/16" FLANGE NYLOC NUT	1
19	82624	BOLT 3/8"-16 X 1" HEX HEAD FLANGE	4
20	82631	NUT, 3/8"-16 HEX FLANGE NYLON	4
21	82021	WASHER, 5/16 USS FLAT Z	1

Parts Explosion: Blower & EMF – Rev N

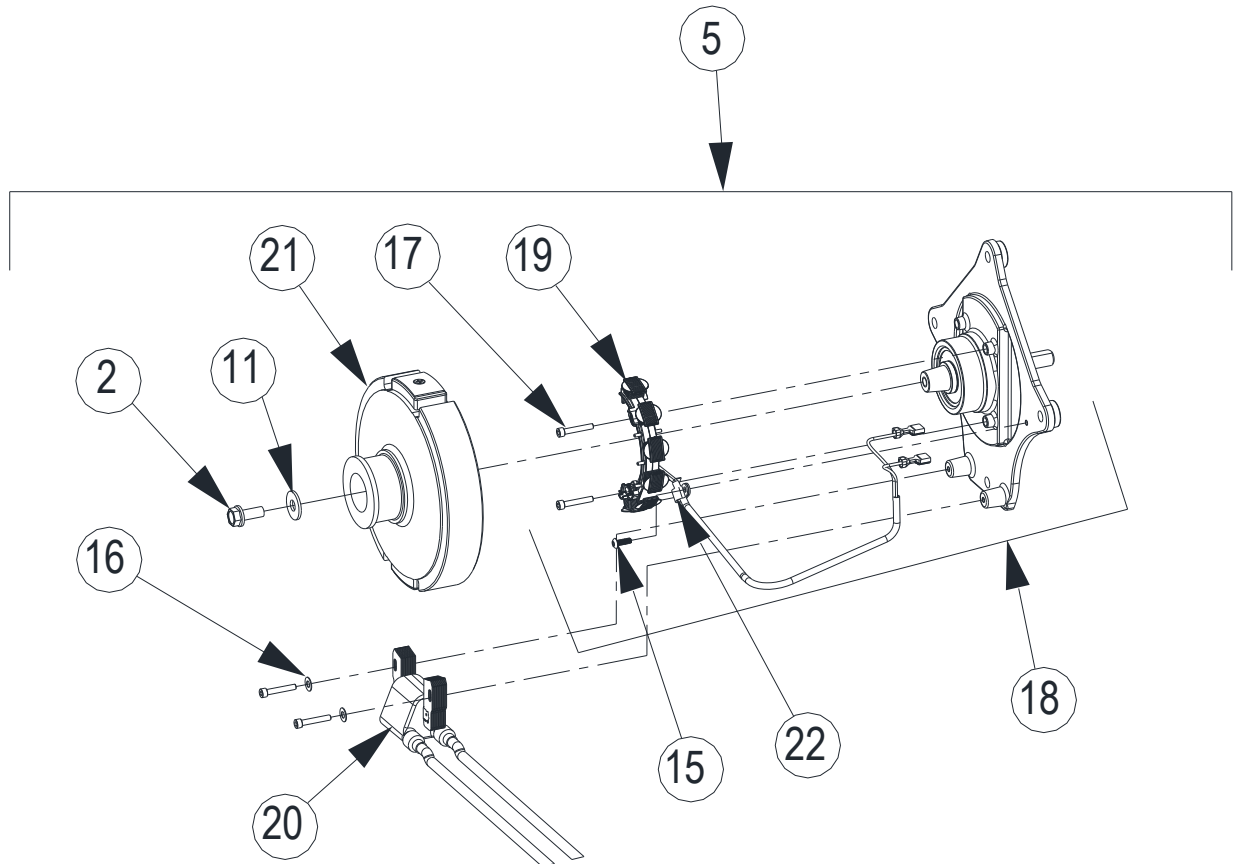

Fig06875

ITEM	PART#	DESCRIPTION	QTY
5		SEE ABOVE TABLE	
2	82015	5/16-18 X 3/4 HHSF BOLT	1
11	788016	2 MM SPACER	1
15	82004	#8-32 x .5 BHCS	1
16	802202	M5 FLAT WASHER	2
17	802343	#8-32 X 1" SHCS	4
18	799538	STATOR ASSY	1
19	799566	STATOR BLADE ASSEMBLY	1
20	800782	IGNITION COIL ASSEMBLY	1
21	799813	FLYWHEEL HUB	1
22	799692	1/4" LOOP CLAMP	1

Parts Explosion: Engine, Water & Fuel Pumps, Drive Parts – Rev N

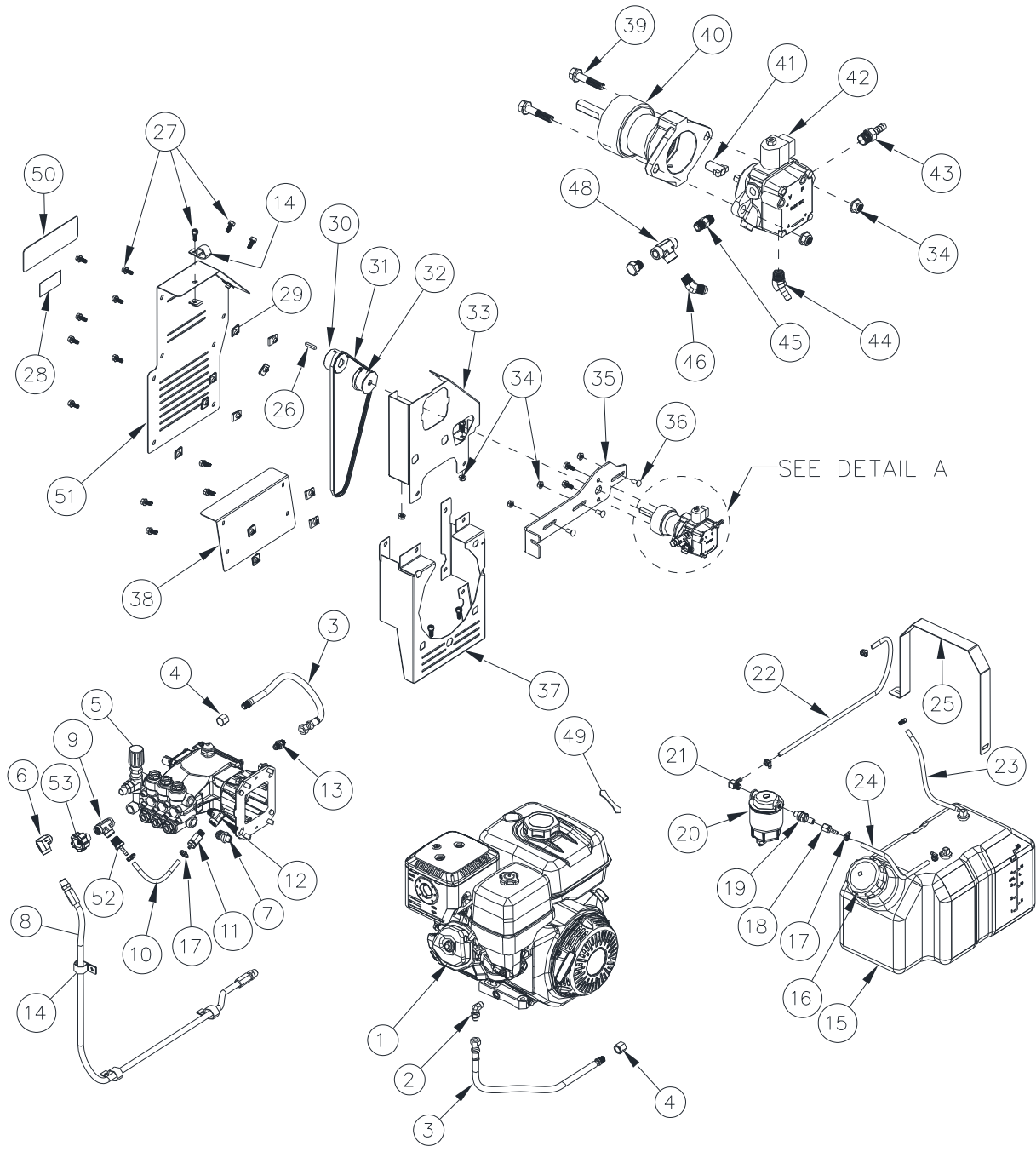

Fig157115_13K

Parts Explosion: Engine, Water & Fuel Pumps, Drive Parts – Rev N

<i>ITEM</i>	<i>PART#</i>	<i>DESCRIPTION</i>	<i>QTY</i>
1	6066	ENGINE, HONDA GX390	1
	HC17210ZE3505	ELEMENT, AIR CLEANER	1
	HC17218ZE3505	FILTER, OUTER	1
	803754	ENGINE, KOHLER CH440	1
2	801096	FITTING MJIC-6 x 12MM	1
3	801089	HOSE, OIL DRAIN	2
4	801097	FITTING, 3/8" FPT CAP	1
5	799630	PUMP, 66DX CAT 4.0@ 3000	1
6	798262	ELBOW, 3/8 FORGED	1
7	777836	PROTECTOR, THERMAL	1
8	799879	HOSE, 3/8X43" 3000 PSI	1
9	777639	TEE, STREET 1/2 STEEL - PW	1
10	777165	CHEMICAL HOSE	0.8"
11	801964	VALVE, EASY START	1
12	777410	ELBOW, 3/8" FORGED- PW	1
13	801447	FITTING, 9/16-18 MALE JIC X 1/4-19 BSPP STRAIGHT	1
14	779666	CLAMP, 1" LOOP	3
15	801494	ASSEMBLY TANK DIESEL 5 GAL	1
16	305206	DIESEL, FUEL CAP	1
17	777834	CLAMP, 1/4" HOSE	6
18	796282	FITTING, 1/4 FPT X 1/4 HB	1
19	795027	FITTING, ELBOW 1/4 NPT BULKHEAD	1
20	799864	FUEL FILTER	1
20.1	799865	FILTER ELEMENT	1
21	783212	1/4" MPT X 1/4" HB ELBOW	2
22	801490	HOSE, 1/4" FUEL LINE (CARB 2020)	1.83'
23	801490	HOSE, 1/4" FUEL LINE (CARB 2020)	.83'
24	801490	HOSE, 1/4" FUEL LINE (CARB 2020)	.67'
25	800512	TANK STRAP	1
26	800144	KEY, M6	1
27	82088	BOLT, 5/16"-18 X .75" CARR	20
28	786632	DECAL, TOTATING MACH. WARN.	1
29	82720	5/16-18 BLACK SHORT EXTRUDED U NUT	19
30	800724	EMF SHEAVE 66DX PUMP	1
31	801477	BELT, 36" MICRO V, J SEC.	1
32	801170	PUMP SHEAVE, 13MM	1
33	801465	PLATE, UPPER BELT GUARD 66DX	1
34	82630	NUT, 5/16-18 FLANGE NYLOC	10
35	801443	BELT TENSION BRACKET	1
36	82088	BOLT, 5/16-18X .75 CARR.	3
37	800048	LOWER BACK GUARD PLATE	1
38	802344	LOWER FRONT GUARD PLATE	1

Parts Explosion: Engine, Water & Fuel Pumps, Drive Parts – Rev N

<i>ITEM</i>	<i>PART#</i>	<i>DESCRIPTION</i>	<i>QTY</i>
39	82622	BOLT, 5/16-18 x 1.5" HHFB	2
40	801636	ASSEMBLY, PUMP MOUNT	1
41	795015	MOTOR/PUMP COUPLER	1
42	792264	FUEL PUMP, 12V	1
42.1	RWB21754U	FUEL SOLENOID COIL, 12V	1
42.2	798628	FUEL SOLENOID STEM	1
43	777340	1/4"MPT X 1/4"HB	1
44	801448	FITTING, 1/4" HB X 1/4" NPT	1
45	801472	FITTING, 1/8" HEX NIPPLE	1
46	794146	FITTING, 1/4 JIC TO 1/8 NPT 45 DEG.	1
48	801471	FITTING, 1/8" TEE	1
49	786501	DECAL, ADD OIL	1
50	800662	DECAL, OP INSTRUCTIONS	1
51	801466	PLATE, BELT GUARD COVER	1
52	799854	FITTING, 1/2" NPT X 1/4" HB	1
53	800783	FILTER, WASHER, 1/2" X 3/4" FGH	1

Parts Explosion: Accessories- Gun, Hose, Chemical Injector – Rev N

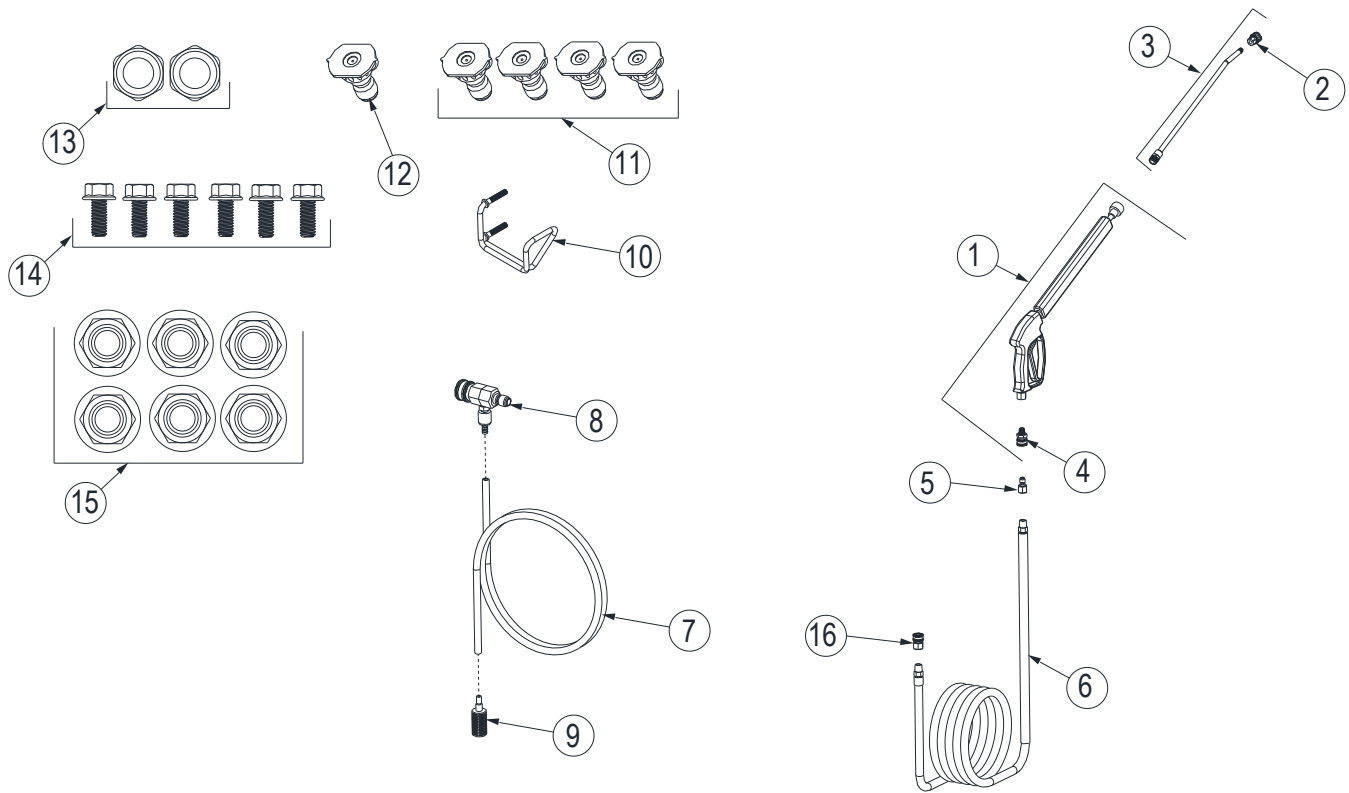
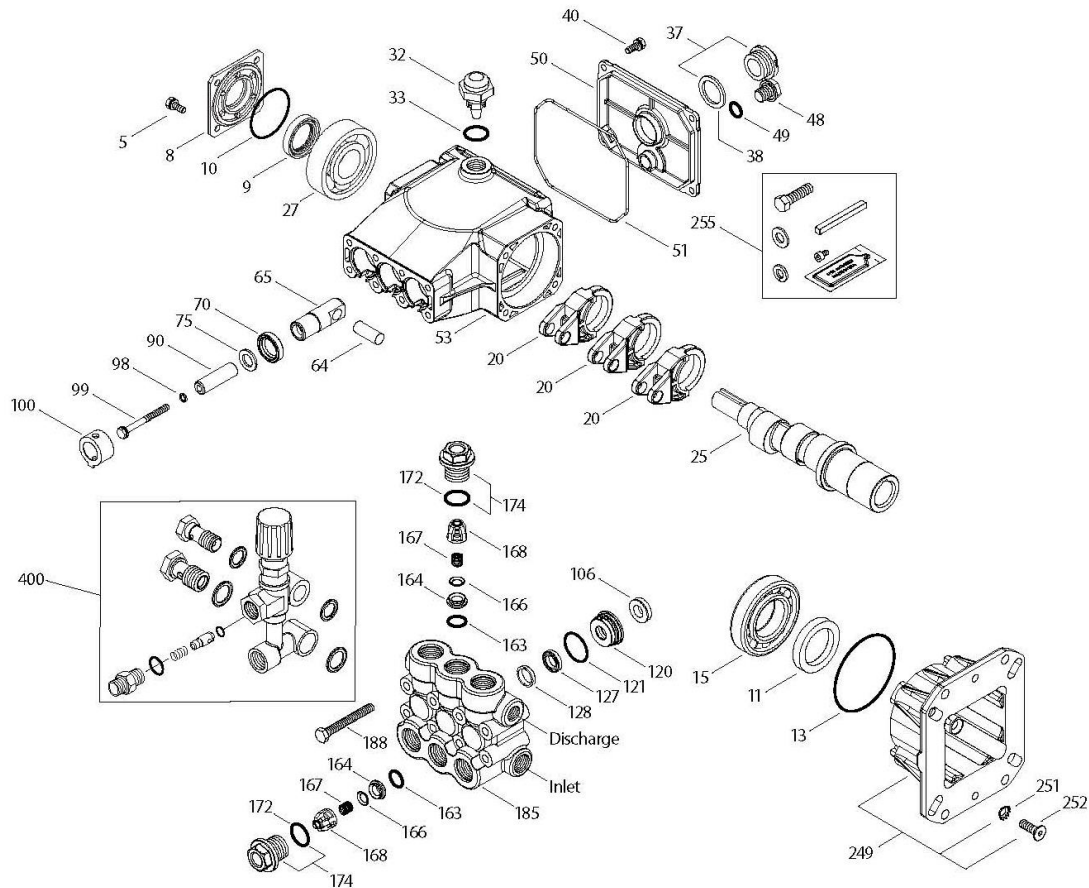

Fig157115-15

ITEM	PART#	DESCRIPTION	QTY
1	779165	GUN WITH LANCE	1
2	791274	1/4 QUICK COUPLER	1
2.1	796379	O-RING (NOT SHOWN)	1
3	791278	LANCE,18.5" W/VITON COUPLER	1
4	780455	3/8" QUICK COUPLE SOCKET X 3/8" MPT	1
4.1	GP2701020	O-RING (NOT SHOWN)	1
5	777915	NIPPLE, 3/8"	1
6	799880	HOSE, 3/8" X 50' HIGH PRESSURE	1
7	777165	CHEMICAL HOSE	4 FT.
8	779614	INJECTOR, QC 3 GPM	1
9	221222	STRAINER, CHEMICAL	1
10	800615	HOSE, HOOK	1
11	803866	NOZZLE 4 PACK, #4.5	1
12	801092	NOZZLE, 15° ORANGE #3.5	1
13	777495	M8-1.25 NYLOCK NUT	2
14	82621	BOLT, 5/16-18 x .75" HEX HEAD FLANGE BOLT	6
15	82630	NUT, 5/16-18 HEX FLANGE NYLOC	6
16	777914	COUPLING, 3/8"	1
16.1	GP2701020	O-RING (NOT SHOWN)	1

Pump Explosion-CAT 66DX- Rev N



REF#	PART#	DESCRIPTION	QTY
5	CA125824	Screw, HHC (M6x16)	4
8	CA46901	Cover, Bearing	1
9	CA43222	Seal, Oil, Crankshaft	1
10	CA14028	O-Ring, Bearing Cover - 70D	1
11	CA125351	Seal, Oil, Crankshaft	1
13	CA14037	O-Ring, Bearing Cover	1
15	CA146421	Bearing, Ball - Inner	1
20	CA48843	Rod, Connecting	3
25	CA134878	Crankshaft 11.4 mm	1
27	CA14480	Bearing, Ball - Outer	1
32	CA46798	Cap, Domed, Oil Filler	1
33	CA14179	O-Ring, Filler Cap - 70D	1
37	CA92241	Gauge, Oil Bubble w/Gasket - 80D	1
38	CA44428	Gasket, Flat, Oil Gauge - 80D	1
40	CA125824	Screw, HHC (M6x16)	4
48	CA25625	Plug, Drain (1/4"x19BSP)	1
49	CA23170	O-Ring, Drain Plug - 70D	1
50	CA48862	Cover, Rear	1
51	CA14048	O-Ring, Rear Cover	1
53	CA48830	Crankcase	1
64	CA46404	Pin, Crosshead	3
65	CA48845	Rod, Plunger	3
70	CA48911	Seal, Oil, Crankcase	3
75	CA48754	Slinger, Barrier	3
90	CA48752	Plunger (M14x47)	3

REF#	PART#	DESCRIPTION	QTY
98	CA46730	Washer Seal, Plunger Retainer - 90D	3
99	CA48201	Retainer, Plunger	3
100	CA48755	Retainer, Seal	3
106	CA45188	Seal, LPS w/S-Spg	3
120	CA48759	Case, Seal	3
121	CA13980	O-Ring, Seal Case - 70D	3
127	CA48758	V-Packing	3
128	CA48757	Adapter, Male	3
163	CA17547	O-Ring, Seat - 85D	6
164	CA45790	Seat	6
166	CA46429	Valve	6
167	CA43750	Spring	6
168	CA44565	Retainer, Spring	6
172	CA17616	O-Ring, Valve Plug - 80D	6
174	CA48760	Plug, Valve w/O-Ring	6
185	CA48846	Head, Manifold	1
188	CA126512	Screw, HSH (M8x65)	8
249	CA48841	Flange, Adapter	1
251	CA126746	Lockwasher, Conical (M8)	4
252	CA46403	Screw, FH (M8x25)	4
255	CA30510	Assy, Bolt Mount	1
300	CA34262	Kit, Seal (Incls: 98,106,121,127,128)	1
310	CA34260	Kit, Valve (Incls: 163,164,166,167, 168,172)	2
400	CA7861	Unloader Assy	1

Pump Explosion-CAT 66DX- Rev N

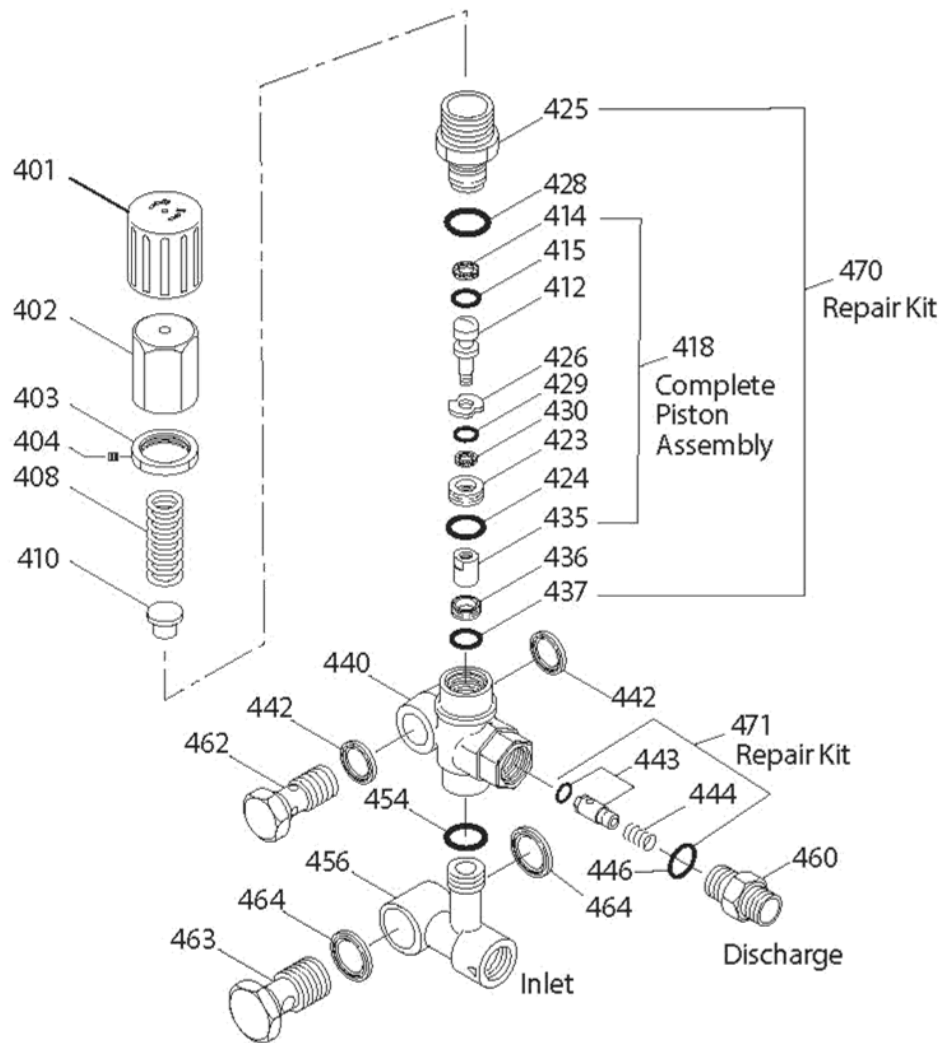

REF#	PART#	DESCRIPTION	QTY
401	CA49100	Handle, Adjusting (Black)	1
402	CA49099	Cap, Adjusting	1
403	CA125521	Nut, Locking (M25x1)	1
404	CA88953	Screw, Set (M4x4)	1
408	CA45198	Spring, Pressure	1
410	CA49101	Retainer, Spring	1
412	—	Stem, Piston	1
414	—	Back-up-Ring, Piston Stem	1
415	—	O-Ring, Piston Stem - 90D	1
418	—	Assy, Piston (Included in Repair Kit)	1
423	CA49105	Retainer, Valve	1
424	—	O-Ring, Valve Retainer - 70D	1
425	—	Retainer, Piston	1
426	—	Washer	1
428	—	O-Ring, Piston Retainer - 80D	1
429	—	O-Ring, Valve Retainer - 70D	1
430	—	Back-up-Ring, Valve Retainer	1

REF#	PART#	DESCRIPTION	QTY
435	—	Valve/Ball Assembly	1
436	—	Seat	1
437	—	O-Ring, Seat - 70D	1
440	—	Valve Body	1
442	CA49121	Washer, Seal (3/8")	2
443	—	Valve, Check w/NBR O-Ring	1
444	—	Spring, Check Valve	1
446	—	O-Ring, Body - 80D	1
454	—	O-Ring, Manifold - 70D	1
456	—	Manifold	1
460	CA126974	Fitting, Discharge [3/8" NPT(M)]	1
462	CA49120	Screw, Flo-Thru [3/8" NPT(M)]	1
463	CA49117	Screw, Flo-Thru [1/2" NPT(M)]	1
464	CA49118	Washer, Seal (1/2")	2
468	CA31708	Kit, O-Ring, (Incls: 414, 415, 424, 428-430, 437, 446, 454)	1
470	CA31556	Kit, Repair (Incls: 418, 425, 428, 436, 437)	1
471	CA76185	Kit, Check Valve (Incls: 443, 444, 446)	1

Wiring Diagram – Rev N

STANDARD CONTROL BOX DIAGRAM (115, 116)

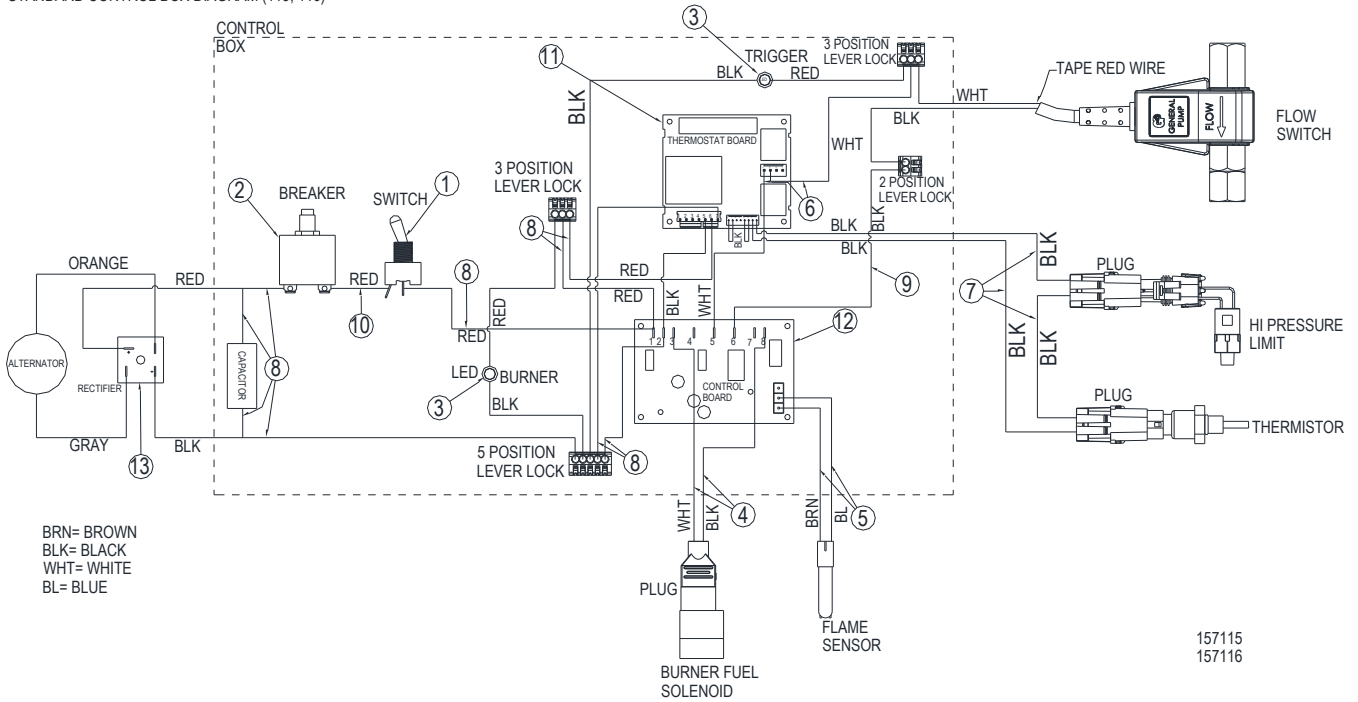

Fig157115_15

Balloon #	Description	Part Number	Qty
1	Switch, Toggle	777855	1
2	Breaker, Circuit, 5 AMP	802307	1
3	LED, Red 12VDC-PW	777646	1
4	Harness, Wire, Fuel Solenoid	800649	1
5	Harness, Wire, Flame Sensor	800624	1
6	Harness, Wire Flow Switch	800594	1
7	Harness, Wire Thermistor /Hi-PSI	799916	1
8	Harness, Wire Power W/Cap	806331	1
9	Harness, Wire Flow Switch To Board	800599	1
10	Harness, Wire Breaker To Switch	800458	1
11	Controller, Temp. Assembly	802972	1
12	Primary Control Board, 12VDC	792287	1
13	Rectifier	799931	1

Summary of Important Safety Information

This section provides a summary of the various safety procedures and measures that have been presented throughout the manual. Keep this summary handy and refer to it to refresh your memory about how to safely use your pressure washer.

WARNING

Carefully read and understand the following safety information before using the pressure washer. Improper use or maintenance of the pressure washer can result in *serious injury or death* to the operator or bystanders from:

- *Carbon monoxide poisoning*
- *Fire/explosion*
- *Chemical exposure*
- *Skin/eye injury from high pressure spray*
- *Burns*
- *Slips/falls*
- *Electric shock*
- *Flying objects/debris*

GENERAL

- **Read all instructions.** Read and understand this Owner's Manual and the engine Owner's Manual completely before attempting to set-up and use the pressure washer. Serious injury or death can result if safety and other instructions are not followed.
- **Instruct all operators.** The pressure washer's owner must instruct all operators and potential renters in safe pressure washer set-up and operation. Do not allow anyone to operate the pressure washer who has not read the Owner's Manual and been instructed on its safe use. Owner's Manuals are available from NorthStar at 1-800-270-0810.
- **Adult control only.** Only trained adults should set up and operate the pressure washer. Do not let children operate. Pressure washers can generate forces greater than children can control and require judgment beyond what can be expected of children.
- **Under the influence.** Never operate, or let anyone else operate, the pressure washer while fatigued or under the influence of alcohol, drugs, or medication.
- **Understand intended use.** Carefully read about and understand the intended use of this pressure washer. Do not use for other purposes, as unforeseen hazards or equipment damage may result.

PROHIBITION AGAINST MODIFICATIONS

Never modify or alter the pressure washer in any way or deactivate any safety device. Modifications can create serious safety hazards and will also void the warranty.

- **Fuel/exhaust system.** Never add to or modify the exhaust system, fuel tank, or fuel lines. Carbon monoxide poisoning, fuel leaks, fire or explosion could result.
- **Unloader valve.** Do not attempt to alter the unloader valve's maximum pressure. Excess pressure could cause serious injury from escaping high-pressure fluids and/or pump damage. Any alteration other than turning the adjustment knob will void your warranty.
- **Guards.** Do not operate pressure washer unless all guards and cover shields are in place.

SAFETY – INSTALLATION & SET-UP

Installation / Initial Set-up

- **Level, heat-resistant surface.** Situate pressure washer on a firm, level, and heat-resistant surface with good drainage. Ensure it sits level and will not slide or shift during operation. Block wheels to prevent movement.
- **Prevent carbon monoxide poisoning – Use outside only!** Exhaust fumes from both the engine and the burner contain carbon monoxide (CO), a poisonous gas you cannot see, smell, or taste. The CO generated by the pressure washer can rapidly accumulate, even in areas that appear to be well ventilated, resulting in dangerous and fatal concentrations within minutes. To prevent dangerous CO build-up:

Summary of Important Safety Information

- ONLY use pressure washer outdoors and at least 20 feet from the home, away from windows, vents, and air intakes, to allow proper ventilation. If you start to feel sick, dizzy, or weak while using the pressure washer, shut off the engine and get to fresh air RIGHT AWAY.
- NEVER run pressure washer in an enclosed or partially enclosed location such as a building, garage, shed, or vehicle. Running a fan or opening windows will not provide adequate ventilation to prevent dangerous CO build-up.
- **Adequate ventilation.** The pressure washer needs adequate, unobstructed flow of air to allow for proper combustion and cooling. Situate so there is adequate clearance around pressure washer to allow for airflow – at least 7' from any non-combustible wall or obstruction. Never place any objects against or on top of pressure washer.
- **CO alarms.** Ensure that working, battery-operated or battery back-up carbon monoxide alarms are used in any dwelling/structure that is in close proximity to the running pressure washer.
- **Hot exhaust - fires.** Exhausts from engine and burner can be extremely hot and cause fire. Position pressure washer so engine and burner exhausts are at least 7' away from combustible objects during operation.
- **Spark arrestor usage.** Equip engine with a spark arrestor if pressure washer will be used near any ignitable forest, brush, or grassy land. See the “Specifications” section of this manual to determine if your pressure washer is already equipped. In such conditions, make sure you comply with applicable local, state and federal codes.

Fuel Safety

Gasoline is highly flammable and explosive; and burner fuels are combustible at warm temperatures. You can be burned or seriously injured when handling fuel. Use extreme care when handling fuel, including these preventative measures:

- **Fuel outdoors.** Fill fuel tank outdoors – never indoors. Fuel vapors can ignite if they collect inside an enclosure. Explosion can result.
- **Use approved container.** Never pump fuel directly into fuel tank at gas station. Static charge can build and ignite fuel. Use an UL approved fuel container to transfer fuel to the engine.
- **Running / hot engine.** A hot engine or burner is hot enough to ignite fuel. Never add fuel or remove fuel cap if engine or burner are running or still hot. Allow engine to cool at least two minutes before adding fuel.
- **Heat / flames / sparks.** Stay away from sources of heat, flame, or sparks while adding fuel.
- **Don't overfill.** DO NOT overfill the fuel tank. Allow at least 1/2" of empty space below the fill neck to allow for fuel expansion.
- **Replace cap.** Replace fuel cap securely before starting engine.
- **Spills.** Clean up fuel spills immediately. Move pressure washer away from spilled fuel on the ground. Wipe fuel off engine and wait 5 minutes for excess fuel to evaporate before starting engine. Fuel soaked rags should be disposed of properly.
- **On skin / clothes.** If fuel is spilled on your skin or clothes, change clothes and wash skin immediately.
- **Inspect fuel system.** Check fuel tanks and fuel system on a regular basis. Look for signs of leaks, deterioration, chafed or spongy fuel hose, loose or missing fuel hose clamps, damaged fuel tank, or a defective fuel shut-off valve. Do not start pressure washer until needed repairs have been completed.
- **Fuel storage.** Store fuel in a cool, dry place in an UL-approved, tightly sealed container.

SAFETY – OPERATION

Pre-start

- **Review safety rules.** Before each use of this pressure washer, review the “Rules for Safe Operation.” Failure to follow these rules may result in serious injury or death.

Summary of Important Safety Information

- **Know how to stop.** Be thoroughly familiar with proper use of the equipment and all controls and connections. Know how to stop the pressure washer and relieve system pressure quickly if needed.
- **Danger: High-pressure fluid injection hazard.** High-pressure fluid spray or discharge from leaks (even pin-sized) or ruptured components can pierce the skin and inject fluid into the body. Injection injury can result in blood poisoning and/or severe tissue damage leading to infection, gangrene and possibly amputation.
- **Check/maintain machine before each use.** Check hoses & fittings for damage and leaks before use. Ensure all components are properly connected. Follow all maintenance instructions specified in pressure washer and engine manuals.
 - Never operate machine with damaged or missing hoses/parts. Never attempt to repair a high-pressure hose or component. Always replace it with a part that is rated at or above the pressure rating of this machine.
 - Never run the machine without sufficient lubrication or sufficient water to cool the pump.
 - Never operate unless all safety guards are in place.
- **Position safely.** Place sprayer on firm, level ground to prevent accidental falls and equipment tip-over.
- **Not in presence of combustibles.** Do not use the pressure washer in the presence of flammable vapors, dust, gases, or other potentially combustible materials. Operate only where open flame or torch is permitted
- **Use backflow preventer.** The use of a back-flow preventer on the water supply hose is recommended and may be required by local code.
- **Clear work area.** Clear work area of all bystanders. Keep children and pets away.
- **Wear protective gear.** High-pressure spray can cause eye/skin injury, hot water can burn, and flying objects/debris can cause injury. Serious injection injury can result if high-pressure spray penetrates the skin. Operators should wear waterproof, thermally insulated gloves, safety glasses with side and top protection, face protection, and protective clothing when operating the machine. If spraying pressure washer specific cleaning chemicals, wear a respirator or mask to avoid inhalation of vapors if directed on the chemical label.
- **Wear non-slip footwear.** Use of pressure washer can create puddles and slippery surfaces. Wear footwear capable of maintaining a good grip on wet surfaces.
- **Check nozzle.** The nozzle can become a projectile and cause serious personal injury or property damage if not properly connected to the spray gun. Check to ensure the nozzle has been properly attached to the spray gun before using the pressure washer.

During use

- **Safety latch locked before starting engine.** Always engage the safety latch on the spray gun trigger before starting the engine.
- **Incoming water supply on.** Do not run the pump without the water supply connected and turned on. Operating the pressure washer without an incoming flow of water will damage the pump.
- **Wait before re-lighting burner.** NEVER attempt to immediately run or re-light the burner if it doesn't ignite the first time. Unburned fuel may have accumulated, causing potential explosion or fire hazard.
- **Use two hands.** Pressure washer spray gun kicks back when triggered. Firmly grasp with two hands.
- **Stay alert.** Watch what you are always doing.
- **Prevent slips / loss of balance.** High-pressure spray could cause you to lose balance from kickback forces, and wet surfaces can be slippery.
 - Always keep good footing and balance.
 - Do not overreach.
 - Do not stand on unstable support when spraying.
 - Use extreme caution when spraying from a ladder or scaffolding, ensure it is firmly anchored from sway or tip-over. Use extreme caution to avoid falling as spray gun kick can propel you off the ladder or scaffolding.

Summary of Important Safety Information

- Be aware of puddles and slippery surfaces. Ensure there is adequate drainage to prevent pooling of water.
- **Keep spray away from people.** Never direct discharge stream at or near any person. Do not allow any part of the body to come in contact with the fluid stream. High-pressure spray will cause serious skin, eye, or falling injuries, and hot water can burn. Injection injury will occur if high-pressure spray pierces the skin, injecting liquid under the skin. Injection injury can result in blood poisoning and/or severe tissue damage leading to infection, gangrene and possibly amputation.
- **Prevent surface damage & flying debris** – Surfaces being sprayed must be strong enough to withstand high-pressure spray, or damage may result. In addition, high-pressure spray will dislodge unsecured objects as well as surface chips and debris, resulting in hazardous flying objects that can cause personal injury or property damage. Do not spray brittle surfaces or breakable, fragile, or unsecured objects such as:
 - stucco or laminar flagstone
 - some painted surfaces
 - windows or glass doors (because they may break)
 - light fixtures, flowerbeds, mailboxes
 - unsecured, lightweight objects
- **Do not lock spray gun trigger in ON position.** To reduce risk of injury, do not attempt to secure the spray gun open by blocking or tying the spray gun in the open position.
- **Keep spray away from electrical wiring.** Spray contact with electrical wiring will likely result in severe electrical shock or electrocution.
- **Use only approved cleaning chemicals.** Only chemicals specifically designed for use in pressure washers may be used. Never spray acids, corrosives, or abrasive or flammable liquids. Breathing hazards, surface burns/corrosion, or fire/explosion could result.
- **Follow cleaning chemical manufacturer's instructions.** Follow the chemical manufacturer's label instructions when handling or spraying chemicals. Understand all safety hazards and first aid for all chemicals being used. Wear protective gear as directed. Always wear protective gloves when handling and cleaning with chemicals. When cleaning filters, check whether dangerous chemicals have been used with the filter and take any precautions that may have been recommended by the supplier of these chemicals. Always dispose of hazardous fluids per local, state, and national guidelines.
- **Do not exceed pressure and or temperature limits.** Do NOT operate this pump with components (such as hose, connections, and spray gun) rated for lower pressure and or temperature limits than the machine's maximum rated pressure and temperature, or component could rupture and cause serious personal injury from escaping high pressure fluids. Do not set the pressure relief device above the rated pressure. **If the high-pressure relief device ever discharges water, turn the engine off and do not use the machine. Call Product Support at 1-800-270-0810.**
- **Never pull by hose.** Do not move this machine by pulling on the hose. Hose or connections could fail and result in catastrophic high-pressure release of fluid as well as hose whipping.
- **Avoid sharp objects.** Keep hose away from sharp objects. Bursting hoses may cause injury.
- **No load bearing.** Do not use the pump to support other items of equipment that impose unacceptable loads on the pump. Do not attempt to use this machine as a prop.
- **Hot exhaust/parts.** Stay clear of engine and burner exhausts. Never touch hot engine muffler, burner/heating coil, or other hot surfaces. All are very hot and will burn you.
- **Hot spray gun metal when using burner.** Never touch the metal screw or any metal parts of the spray gun when the heater is being used – the metal gets very hot and will burn you.
- **Smoking/sparks.** Never smoke near the running engine, and never operate near sources of sparks or flames as flammable fuel vapors are in the vicinity of the pressure washer.
- **Lock trigger safety latch when not spraying.** Spray gun is equipped with a built-in trigger safety latch to guard against accidental trigger release. Rotate safety latch to the locked position when not spraying.

Summary of Important Safety Information

- **Relieve water pressure.** Always stop the product and relieve system pressure before leaving the sprayer unattended, or when disconnecting hoses, removing nozzles, or servicing the pump.
- **Refueling.** Never add gasoline to the engine or fuel to the burner unless unit is off and has cooled.
- **Do not direct spray at this machine.** Do not attempt to clean this machine with its own spray. Engine damage will result. Cleaning should be done with a damp sponge with the engine OFF.
- **Seek medical aid for suspected carbon monoxide poisoning.** The running engine gives off carbon monoxide, a poisonous gas that can kill you. If you start to feel sick, dizzy, or weak while using the pressure washer, shut off the engine and get to fresh air RIGHT AWAY. See a doctor. You may have carbon monoxide poisoning.
- **Seek medical aid for suspected injection injury.** If injured by high-pressure fluid, no matter how small the wound is, see a doctor at once. A typical injection injury may be a small puncture wound that does not look serious. However, severe infection or reaction can result if proper medical treatment is not administered immediately by a doctor who is familiar with injection injuries.
- **Other exhaust dangers.** This product contains or emits chemicals known to the State of California to cause cancer, birth defects or other reproductive harm. Avoid inhalation of exhaust.

After use

- **Cool engine before storing.** Let engine cool for at least five minutes before storing. A hot engine is a fire hazard.
- **Prevent accidental starting.** When pressure washer is not in use, remove spark plug or spark plug wire in order to ensure that pressure washer cannot be started in a storage location or by untrained persons.
- **Storage location.** Store the pressure washer in a dry location away from sources of heat, open flames, sparks or pilot lights – such as water heaters, space heaters, furnaces, clothes dryers, or other gas appliances – EVEN IF the pressure washer's gas tank is empty, residual vapors or fuel could ignite.
- **Periodic maintenance.** Perform periodic maintenance as directed in this manual to keep the pressure washer in safe working condition.

SAFETY - INSPECTION/MAINTENANCE

Inspect and maintain your pressure washer on a regular basis and repair as needed to keep it in safe working condition:

- **Turn off / relieve pressure first.** Turn off pressure washer and relieve system pressure before inspection or maintenance. Remove spark plug or spark plug wire before working on the engine or pressure washer to prevent accidental starting.
- **Fuel valve off.** Turn fuel shut-off valve to OFF position before transporting or servicing the pressure washer.
- **Follow maintenance schedule.** Follow all maintenance instructions in this pressure washer manual and the engine manual.
- **Replace guards / shields.** Make sure all guards and shields are replaced after servicing the pressure washer.
- **Replacement parts.** If a part needs replacement, only use factory approved repair parts. Replacement parts that do not meet specifications may result in a safety hazard or poor operation of the pressure washer and will void the warranty.

Limited Warranty

Dear Valued Customer:

The NorthStar Product you just purchased is built with the finest material and craftsmanship. Use this product properly and enjoy The benefits from its high performance. By purchasing a NorthStar product, you show a desire for quality and durability. Like all mechanical equipment this unit requires a due amount of care. Treat this unit like the high quality piece of machinery it is. Neglect and improper handling may impair its performance. Please thoroughly read the instructions and understand the operation before using your product. Always contact NorthStar Product Support at 1-800-270-0810 prior to having any service or warranty work performed, as some services performed by parties other than NorthStar approved service centers may void this warranty. This warranty is in lieu of any other warranty expressed or implied and NorthStar assumes no other responsibility or liability outside that expressed within this warranty.

Limited Warranty

NorthStar shall warranty any piece of equipment manufactured, or parts of equipment manufactured, to be free from defects in material or workmanship for a period of:

Item	Commercial/Consumer Warranty	Details
Structural Steel Components	2 years from date of purchase	NorthStar shall warrant structural steel components from failure for a period of 2 years from the date of purchase by user. Structural steel parts include but are not limited to, Frame, handle, Roll cage, bumper, and axles.
Heat Exchanger Coil Weldment	5 years from date of purchase	NorthStar shall warrant the Coil from defects in material or workmanship for a period of 5 years from the date of purchase by user. Warranty does not cover damage from freezing, or obstruction due to buildup of scale or soot.
Pump	5 years from date of purchase, Lifetime on pump manifold	NorthStar shall warrant the pressure wash pump to be free of defects in material and workmanship for a period of 5 years.
Engine	3 years from date of purchase	The engine warranty is covered under the terms and conditions as outlined by the engine manufactures warranty and is the sole responsibility of the engine manufacture. Normal engine maintenance such as spark plugs, air filters, adjustments, fuel system cleaning and obstruction due to build up is not covered by this NorthStar warranty.
NorthStar	2 years from date of purchase	The Balance of the machine less the other specific warranties mentioned.
Chemical injector & Unloader	90 days from date of purchase	NorthStar shall warrant the Chemical injector and Unloader valve from defects in material or workmanship for a period of 90 days from the date of purchase by user.
Normal wear items	90 days from date of purchase	In addition to the normal warranty, NorthStar shall warrant any normal wear item from defects in material or workmanship for a period of 90 days from the date of purchase by user. Normal wear items include, but are not limited to, nozzles, quick connect fittings, valves, high and low pressure water seals/packing, high and low pressure hoses, O-rings, filter elements, Electrodes, Gun, Lance, Tires, and Brakes

Limited Warranty

“Consumer use” means personal residential household use by a consumer. “Commercial use” means all other uses, including use for commercial, income producing or rental purposes or when purchased by a business.

This warranty applies to the original purchaser of the equipment (verification of purchase, in the form of a receipt, is the responsibility of the buyer), is non-transferable, and covers parts and labor. Parts will be replaced or repaired at no charge, except when the equipment has failed due to lack of proper maintenance. If a part is no longer available, the part may be replaced with a similar part of equal function. Any misuse, abuse, alteration or improper installation or operations will void warranty. Determining whether a part is to be replaced or repaired is the sole decision of NorthStar. NorthStar will not provide for replacement of complete products due to defective parts. Any costs incurred due to replacement or repair of items outside of a NorthStar approved facility is the responsibility of the buyer and not covered under warranty. Transportation costs to and from service center is the responsibility of the customer.

This warranty specifically excludes the following: failure of parts due to damage caused by accident, fire, flood, windstorm, acts of God, applications not approved by NorthStar in writing, corrosion caused by chemicals, use of replacement parts which do not conform to manufacturer’s specifications, damage related to the use of biodiesel fuel, damage to accessory parts such as starting batteries, damage related to rodent and/or insect infestation, Damage caused by freezing and damage caused by vandalism. Additional exclusions: loss of running time, inconvenience, loss of income, or loss of use, including any implied warranty of merchantability of fitness for a specific use. Also, Outdoor Power Equipment needs periodic parts and service to perform well, and this warranty does not cover instances when normal use has exhausted the life of a component or the engine.

This warranty does not cover any personal injury or damage to surrounding property caused by failure of any part. Repair or replacement of parts does not extend the warranty period.

Normal burner maintenance such as cleaning and adjusting electrodes, descaling the coil, desooting the coil, air adjustments, fuel system cleaning and obstruction due to build up is not covered by this NorthStar warranty.

The engine warranty is covered under the terms and conditions as outlined by the engine manufactures warranty contained herein and is the sole responsibility of the engine manufacture. Normal engine maintenance such as spark plugs, air filters, adjustments, fuel system cleaning and obstruction due to build up is not covered by this NorthStar warranty.

Please fill in the following information and have it on hand when you call in on a warranty claim.

Customer Number: _____

Date of Purchase: _____

NorthStar Serial Number: _____

Item Number: _____

This page is intentionally left blank

▲WARNING: This product can expose you to chemicals including gasoline engine exhaust, which is known to the State of California to cause cancer, and carbon monoxide, which is known to the State of California to cause birth defects or other reproductive harm.

For more information go to www.P65Warnings.ca.gov. **Good**



Manufactured by
Northern Tool + Equipment Co.,
Burnsville, MN 55306
NorthernTool.com