



M1571101L

ITEM NUMBER: 1571101, 1571102, 1571103,
1571104, 1571105

SERIAL NUMBER: _____

Owner's Manual

Pressure Washer: Machine that cleans dirty surfaces with high pressure water.

Instructions for Installation/Set-up, Operation, Maintenance, & Storage

This pressure washer produces cold-water high-pressure spray. Cleaning chemicals may be incorporated into the spray if desired. The pressure pump for this equipment is powered by an electric motor.

⚠ WARNING

SPECIAL HAZARDS

- **Injection Injury:** High-pressure spray can pierce skin and underlying tissues, leading to serious injury and possible amputation. Such an injection injury can result in blood poisoning and/or severe tissue damage.
- **Flying Debris:** High-pressure spray can cause flying debris and possible surface damage.
- **Electric Shock:** Operating equipment in wet conditions or near water can cause electric shock.
- **Chemical Exposure:** Cleaning chemical vapors or contact with skin may be hazardous.
- **Fire/Explosion:** Motor sparking can ignite fuel or other flammable liquids or vapors in the vicinity.
- **Burns:** Pressure washer pump and motor are hot surfaces that can cause burn injuries.

Detailed safety information about these hazards appears throughout this manual.

Equipment Protection Quick Facts

Inspect Upon Delivery: FIRST! Inspect for missing or damaged components. See "Initial Set-Up" section for where to report missing or damaged parts.

Pump: Pump is shipped with oil. Check pump oil level before starting. Remove shipping plug and install vented fill cap.

Water Flow Requirements: Make sure your supply water flow rate is 20% higher than the pressure washer's flow rate (see "Operations" section for detail) and that your water is clean and particle free.

Chemical Spraying: Use only approved pressure washer chemicals designed for high-pressure use.

Storage: Do not allow water to freeze in the pump, hose, or spray gun(s). See "Storage" for more information.

Maintenance Schedule: Motor and pump require periodic inspection and servicing to keep pressure washer functioning efficiently. See "Maintenance Schedule Summary" for frequency of servicing.

Any Questions, Comments, Problems, or Parts Orders
Call NorthStar Product Support 1-800-270-0810

Table of Contents

Equipment Protection Quick Facts	1
TABLE OF CONTENTS	2
ABOUT YOUR PRESSURE WASHER	4
SPECIFICATIONS	6
COMPONENT IDENTIFICATION	7
SAFETY	8
Hazard Signal Word Definitions	8
SAFETY LABELING	9
Safety Decal Locations	9
INITIAL SET-UP	11
Step 1. Inspect & Unpack	11
Step 2. Assembly	13
Handle & Billboard Assembly	13
Spray Gun Assembly	13
Replace Shipping Plug.....	13
Step 3. Select Suitable Location	14
Moving and Handling	14
Step 4. Verify Electrical Connection	14
Grounding	14
Ground Fault Circuit Interrupter Protection	14
Extension Cord.....	15
OPERATION	16
Follow Safety Rules for Operation	16
Preparing for Operation	17
Check/Add Oil to Pump.....	17
Connect Hoses, Water Supply, and Spray Nozzle	18
Prime the Water Supply	19
Set Up for Chemical Spray (if desired)	20
Start-Up Procedures	21
Start the Motor to Power the Pump	21
Apply Cleaning Chemical (if desired)	21
Begin High Pressure Spray	21
Shutdown	22
STORAGE	23
Between Use Storage	23
Prepare Pressure Washer for Freezing Conditions	23
Prepare Pressure Washer for Storage	23
MAINTENANCE & REPAIR	24
MAINTENANCE SCHEDULE SUMMARY	24
DETAILED INSTRUCTIONS – MAINTENANCE & REPAIR	24
Follow Safety Rules	24
Keep Pressure Washer Clean.....	24
Inspect Spray System	24

Clean Inlet Filter	25
Change Pump Oil.....	26
TROUBLESHOOTING	27
PARTS EXPLOSION- MODEL #1571101	28
PARTS LIST - MODEL #1571101.....	29
PARTS EXPLOSION- MODEL #1571102 & 03	30
PARTS LIST - MODEL #1571102 & 03	31
PARTS LIST - MODEL #1571102 & 03	32
PARTS EXPLOSION - MODEL #1571104 & 05	33
PARTS LIST - MODEL #1571104 & 05	34
PARTS LIST - MODEL #1571104 & 05	35
PUMP ASSEMBLIES.....	36
PUMP EXPLODED VIEW – CAT 4DX	37
PUMP PARTS LIST – CAT 4DX.....	38
PUMP EXPLODED VIEW – CAT 4DNX	39
PUMP EXPLODED VIEW – CAT 4DNX	40
PUMP EXPLODED VIEW – GP PUMP	41
PUMP EXPLODED VIEW – GP PUMP	42
PUMP EXPLODED VIEW – GP PUMP	43
PUMP EXPLODED VIEW – GP EP1812 PUMP	44
PUMP PARTS LIST – GP EP1812 PUMP	45
PUMP PARTS LIST – GP EP1812 PUMP	46
WIRING DIAGRAM	47
LIMITED WARRANTY	49
LIMITED WARRANTY CONTINUED	50
CALIFORNIA PROPOSITION 65 INFORMATION	52

About Your Pressure Washer

Thank you for purchasing a NorthStar Pressure Washer! It is designed for long life, dependability, and top performance.

Intended Use. Produce a high-pressure water spray. Incorporate cleaning chemicals into a low-pressure water spray.

Note: Do not use for other purposes, as unforeseen hazards or equipment damage may result.

Power Source. The pressure washer is powered by an electric motor.

Supplies Required. Normal operation will require you to supply:

- Pressure Washer pump oil
- Electric supply
- Personal Protection Equipment

See “*Specifications*” section of this manual for more detail.

Personal Protection. Wear safety apparel during operation, including safety glasses with side and top protection. Ear protection is also recommended if working near any operating machine. Other safety apparel includes waterproof, insulated gloves and non-slip protective footwear. Cleaning chemicals may require the use of respiration mask; refer to the chemical label for further instruction.

Adult Control only. Only trained adults should set up and operate the pressure washer. Do not let children operate the pressure washer.

Under the Influence. Never operate, or let anyone else operate, the pressure washer while fatigued or under the influence of alcohol, drugs, or medication.

Keep this manual for reference and review.

ATTENTION: Rental Companies and Private Owners who loan this equipment to others!

All persons to whom you rent/loan this pressure washer to must have access to and read this manual. Keep this owner's manual with the pressure washer at all times and advise all persons who will operate the pressure washer to read it. You must also provide personal instruction on how to safely set-up and operate the pressure washer and remain available to answer any questions a renter/borrower might have. Owner's Manuals are available from NorthStar at 1-800-270-0810.

Specifications

1571101	
FLOW OUTPUT	
PSI (bar)	1700 (118)
GPM (l/min)	1.5 (5.7)
Max Water Temp	165° F (74°C)
MOTOR	
Motor Horsepower	1.5 HP
Ampere	15A
Voltage	120V
DIMENSIONS/COMPONENTS	
Length	40.25"
Width	26.00"
Height	23.00"
Pump Model	GP EVO
Pump Oil Capacity	4.7 oz
Nozzle orifice Size	#2.0
SUPPLIES REQUIRED (not included)	
Pump Oil (Shipped with oil but refills required)	SAE 30 Non-Detergent Oil or Pressure washer Pump Oil (Part# 4043)
Plug Type	NEMA-5-15R

1571102	
FLOW OUTPUT	
PSI (bar)	2000 (138)
GPM (l/min)	1.5 (5.7)
Max Water Temp	140°F (60°C)
MOTOR	
Motor Horsepower	2.0 HP
Ampere	20A
Voltage	120V
DIMENSIONS/COMPONENTS	
Length	40.25"
Width	26.00"
Height	23.00"
Pump Model	Cat 4DX
Pump Oil Capacity	8.5 oz
Nozzle orifice Size	#2.0
SUPPLIES REQUIRED (not included)	
Pump Oil (Shipped with oil but refills required)	SAE 30 Non-Detergent Oil or Cat Pump Oil (Part# 22158)
Plug Type	NEMA-5-20R

1571103	
FLOW OUTPUT	
PSI (bar)	3000 (207)
GPM (l/min)	2.5 (9.4)
Max Water Temp	140° F (60°C)
MOTOR	
Motor Horsepower	5.0 HP
Ampere	30A
Voltage	240V
DIMENSIONS/COMPONENTS	
Length	40.25"
Width	26.00"
Height	23.00"
Pump Model	Cat 4DNX
Pump Oil Capacity	8.5 oz
Nozzle orifice Size	#3.0
SUPPLIES REQUIRED (not included)	
Pump Oil (Shipped with oil but refills required)	SAE 30 Non-Detergent Oil or Cat Pump Oil (Part# 22158)
Plug Type	NEMA-6-30R

1571104	
FLOW OUTPUT	
PSI (bar)	2000 (138)
GPM (l/min)	4.0 (15.1)
Max Water Temp	165°F (74°C)
MOTOR	
Motor Horsepower	6.2 HP
Ampere	30A
Voltage	240V
DIMENSIONS/COMPONENTS	
Length	40.25"
Width	26.00"
Height	23.00"
Pump Model	GP EP1812
Pump Oil Capacity	15.0 oz
Nozzle orifice Size	#5.5
SUPPLIES REQUIRED (not included)	
Pump Oil (Shipped with oil but refills required)	SAE 30 Non-Detergent Oil or Pressure washer Pump Oil (Part# 4043)
Plug Type	NEMA-6-30R

Specifications

1571105	
FLOW OUTPUT	
PSI (bar)	3000 (207)
GPM (l/min)	4.0 (15.1)
Max Water Temp	165° F (74°C)
MOTOR	
Motor Horsepower	8.2 HP
Ampere	50A
Voltage	240V
DIMENSIONS/COMPONENTS	
Length	40.25"
Width	26.00"
Height	23.75"
Pump Model	GP EP1812
Pump Oil Capacity	15.0 oz
Nozzle orifice Size	#4.5
SUPPLIES REQUIRED (not included)	
Pump Oil (Shipped with oil but refills required)	SAE 30 Non-Detergent Oil or Pressure washer Pump Oil (Part# 4043)
Plug Type	NEMA-6-50R

Component Identification

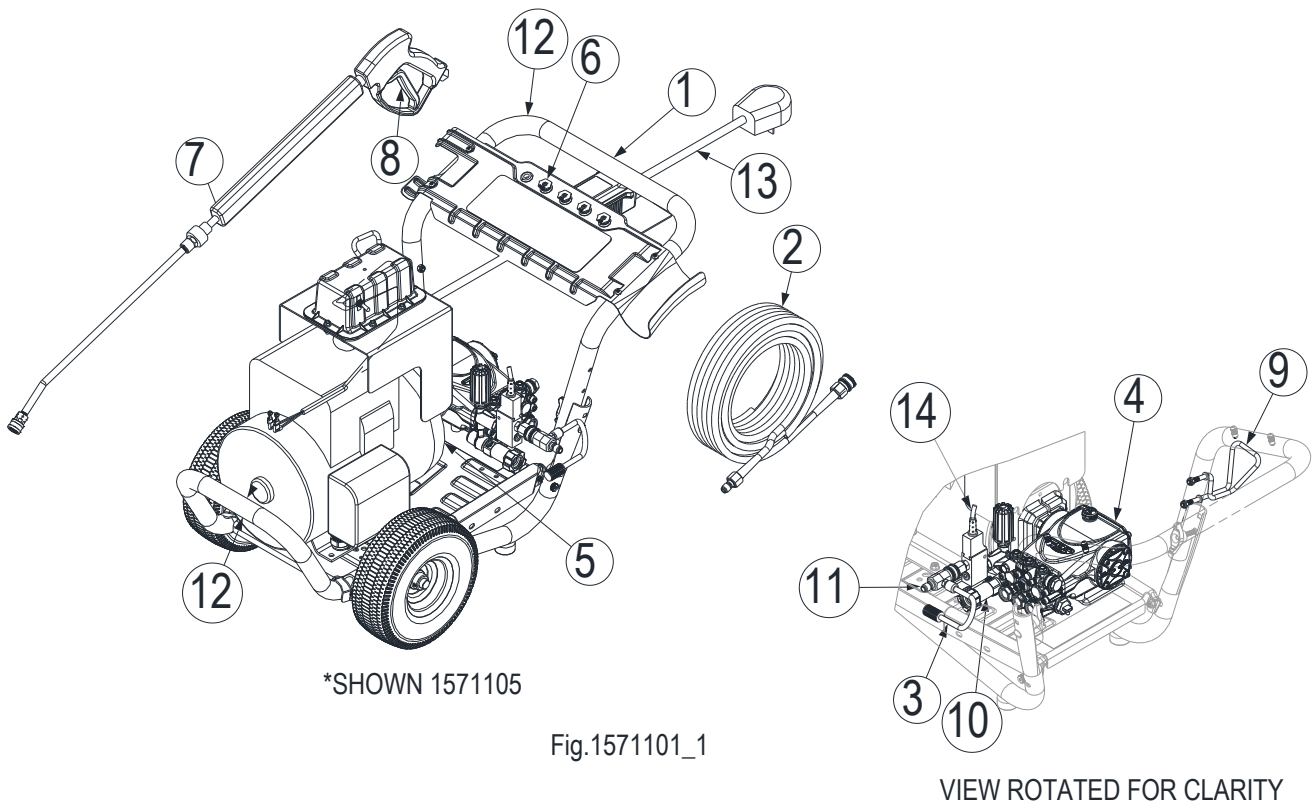

1. **Handle:** Designed for easy cart movement.
2. **High-Pressure Hose:** Attach quick couplers to gun and high-pressure outlet.
3. **Chemical Hose:** Submerge in cleaning solution.
4. **Water Pump:** Inspect for loose/broken parts prior to each use.
5. **Motor:** Motor provides years of reliable use and powers the pump.
6. **Nozzle:** Change nozzles for different spray pattern or cleaning chemical application.
7. **Spray Gun:** Always use two hands for safe operation.
8. **Trigger:** Actuate to allow pressurized water to flow out of spray gun.
9. **Cord Hook:** Store electrical cord on hook.
10. **Garden Hose Inlet:** Connect water supply for pump.
11. **High-Pressure Outlet:** Connect your high-pressure hose.
12. **Lifting Points:** Lift the pressure washer from these points when transporting.
13. **GFCI cord:** For protected power supply.
14. **Total Start/Stop Switch:** Automatically shuts motor off when not spraying.

See "Parts Explosion" for more details

Safety

Hazard Signal Word Definitions



This is the safety alert symbol. It is used to alert you to potential personal injury hazards. Obey all safety messages that follow this symbol to avoid possible injury or death.

DANGER (red) indicates a hazardous situation, which if not avoided, will result in death or serious injury.

WARNING (orange) indicates a hazardous situation, which if not avoided, could result in death or serious injury.

CAUTION (yellow) used with the safety alert symbol, indicates a hazardous situation, which if not avoided, could result in minor or moderate injury.

CAUTION (yellow) without the safety alert symbol, is used to address practices not related to personal injury.

NOTICE is used to address practices not related to personal injury.

Safety Labeling

Safety Decal Locations

WARNING

ALWAYS make sure safety labels are in place and in good condition. If a safety label is missing or not legible, order new labels from NorthStar Product Support at 1-800-270-0810.

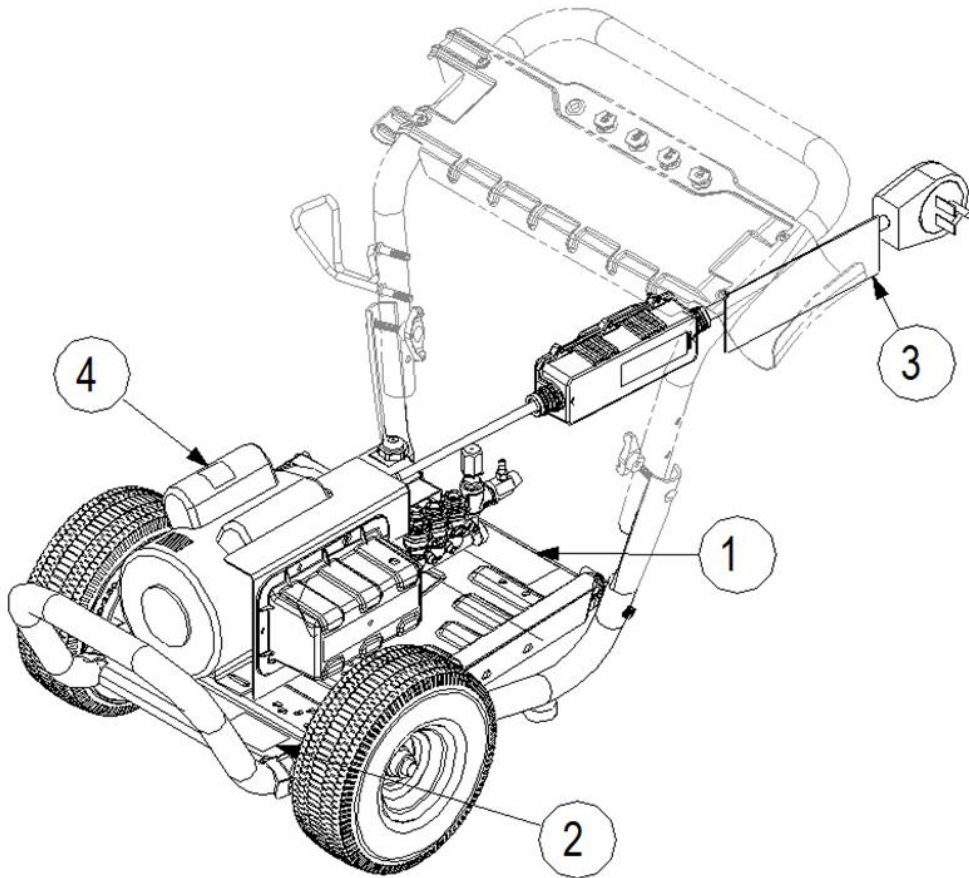

Fig.1571101_2

On-Product Warning Labels		
Location	Part Numbers	Description
1	801049	Instruction Label
2	802940	Decal, High Pressure Spray Hazard
3	778070	Decal, Cord Warning
4	N/A	Serial Number

Safety Labeling

Safety Decals

1

WARNING

OPERATING INSTRUCTIONS:

START UP	SHUT DOWN
1. Attach garden hose.	1. Turn engine/motor OFF.
2. Attach pressure hose.	2. Turn water supply OFF.
3. Attach gun and lance.	3. Squeeze trigger to relieve system pressure.
4. Turn water supply ON.	4. Remove garden hose.
5. Squeeze trigger to purge air from pump.	5. Remove pressure hose.
6. Insert nozzle.	6. Turn fuel valve OFF. (if equipped).
7. Start engine.	

1.) Skin puncture hazard. Do not direct spray at people or animals. Seek IMMEDIATE surgical treatment.
 2.) Risk of fire and explosion. Do not spray flammable liquids.
 3.) Risk of injury. Recoil starter rope (if equipped) can retract rapidly resulting in bodily injury. ALWAYS relieve spray gun pressure before starting. Pull starter rope (if equipped) slowly until resistance is felt, then pull rapidly.
 4.) Risk of electrocution. Keep water away from electric outlets and electric devices.
 5.) Always wear properly rated safety goggles or face shield while spraying.
 6.) Gun kicks back. Hold with both hands.
 7.) Read owner's manual. Serious injury or death can result if safety instructions are not followed.

For questions, replacement parts or labels contact product support at www.northerntool.com or call 1-800-270-0810.

801049

2

WARNING

High Pressure Spray Hazard

- High pressure spray can cause injection injury, eye injury, and loss of balance. Serious injury could result from unintentional release of high-pressure spray from the gun upon engaging the trigger.
- ALWAYS turn Power Switch to OFF position and relieve system pressure when leaving pressure washer unattended.
- Total Start/Stop feature allows temporary motor shut-off (STOP) when the Trigger is disengaged and allows motor turn-on (START) when the Trigger is reengaged. This Feature should NEVER be used to shut-off the pressure washer when not in use.

802940

3

WARNING

RISK OF ELECTROCUTION

1. Connect only to properly grounded outlet. Do not remove ground pin.
2. Inspect cord before using - Do not use if cord is damaged.
3. Keep all connections dry and off the ground.
4. Do not touch plug with wet hands.
5. This product is provided with a Ground Fault Circuit Interrupter built into the power cord plug. If replacement of the plug or cord is needed use only identical replacement parts.
6. Read owner's manual before using.

DO NOT REMOVE THIS TAG

©2005 NT+E Co. 800-270-0810

Part No. 778070

Manufactured by: **NORTH STAR**
Proven Performance
 K-BAR Industries Inc.
 Faribault, MN 55021

PRESSURE WASHER

SERIAL NUMBER: _____
 ENGINE MODEL: _____
 CYLINDER: _____
 PUMP FLOW: _____

ITEM NUMBER: _____
FIG04906

JAW

To order replacement safety labels, call NorthStar Product Support at 1-800-270-0810.

Initial Set-Up

Step 1. Inspect & Unpack

Upon receiving your item check for missing or damaged parts.

See “*Component Identification*” section of this manual for a diagram of the pressure washer and its components.

- For missing or damaged components, contact Product Support at 1-800-270-0810.
- If complete, fill out product serial number information. See “*Limited Warranty*” section of this manual.

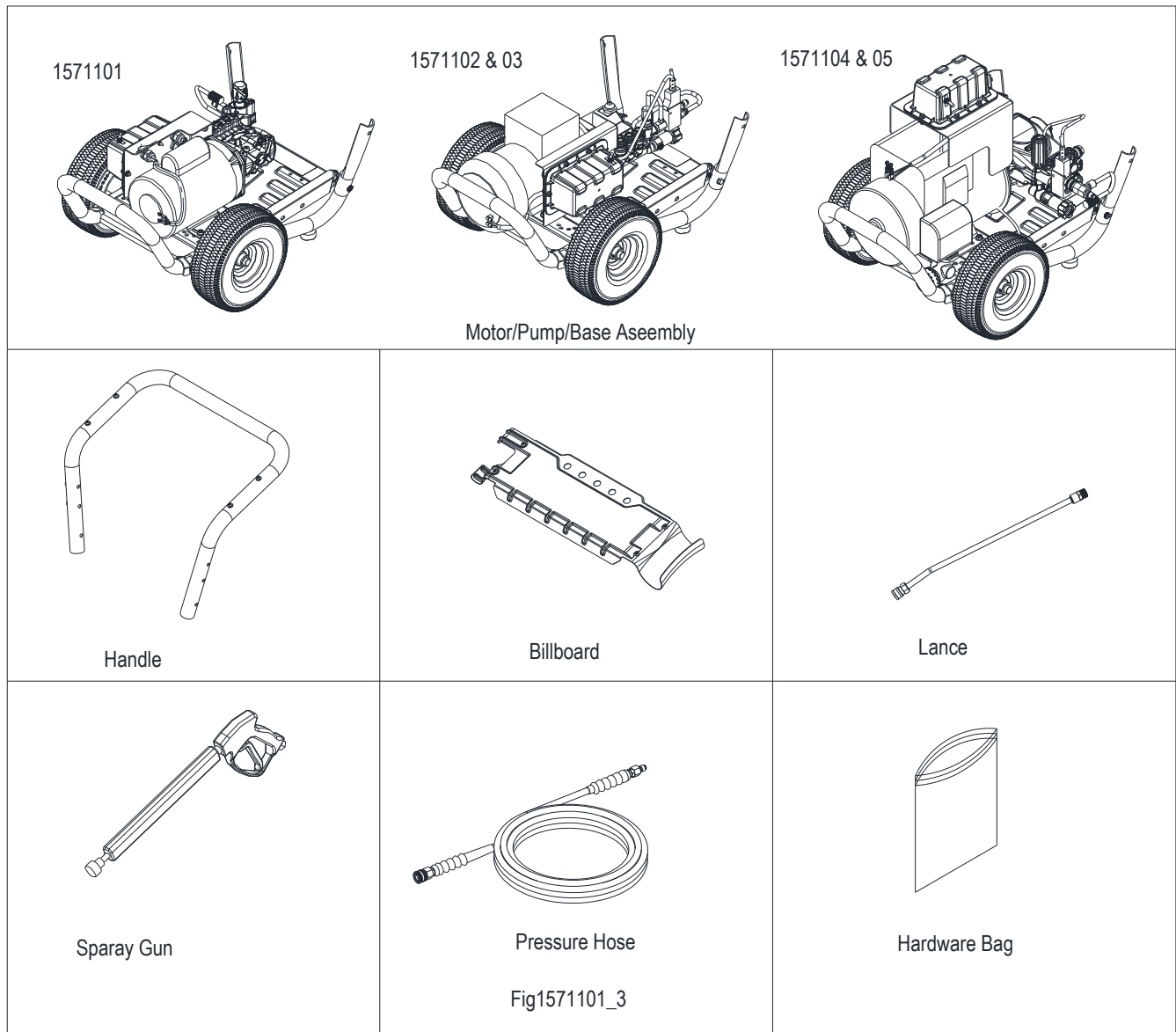

Any Questions, Comments, Problems or Parts Orders call NorthStar Product Support at 1-800-270-0810.

Initial Set-Up

Hardware Bag

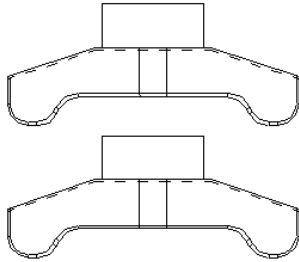

T-HANDLE KNOB
PART# 38578
QTY-2

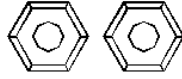

NYLON LOCK NUT
PART# 777495
QTY-2

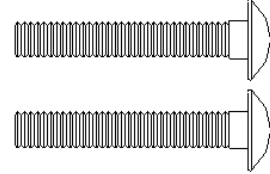

CARRIAGE BOLT
PART# 82233
QTY-2

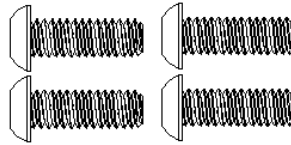

BOLT
PART# 87170
QTY-4

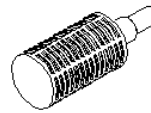

STRAINER
PART# 221222
QTY-1

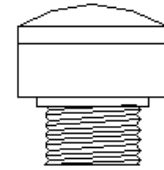

VENTED FILL CAP
(ALL MODEL)
QTY-1

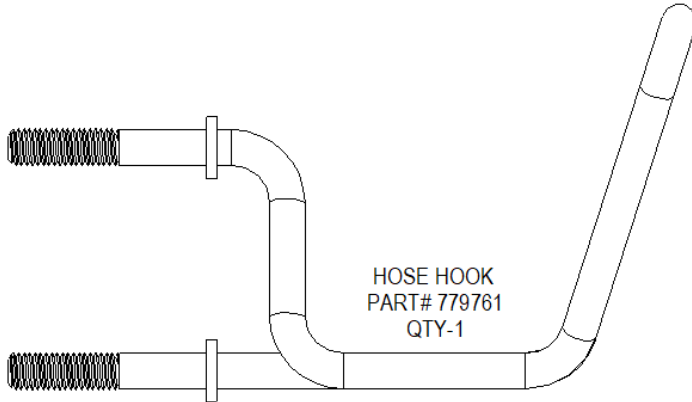

HOSE HOOK
PART# 779761
QTY-1

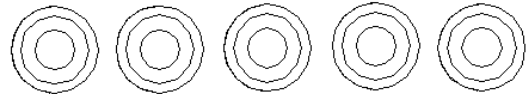

GROMMET
PART# 35198
QTY-5

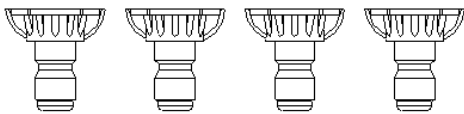

NOZZLE PACK
PART# 802890 (FOR 1571101 & 02)
PART# 800110 (FOR 1571103)
PART# 800425 (FOR 1571104)
PART# 800653 (FOR 1571105)
QTY-1

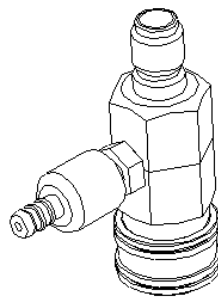

CHEMICAL INJECTOR
PART# 779613 (FOR 1571104 & 05)
QTY-1

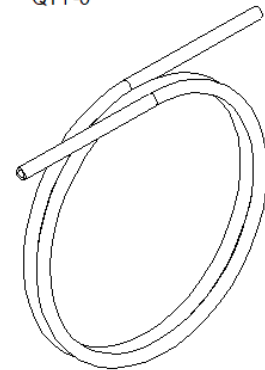

BRAIDED CHEMICAL HOSE
PART# 777165
QTY-3FT

Fig.1571101_4

Initial Set-up

Step 2. Assembly

Note: Remove contents from packaging to begin assembly.

Handle & Billboard Assembly

1. Attach handle to bumper tube using:
 - a. (2) Carriage Bolts (82233)
 - b. (2) T-Handle Knobs (38578)
2. Mount the billboard to the handle using:
(4) bolts (87170).
3. Mount the hose hook onto the handle using:
(2) Nyloc Nuts (777495)
4. Insert grommets into the holes on the handle nameplate.
5. Press nozzles into grommets according to the colors indicated on the billboard decal.

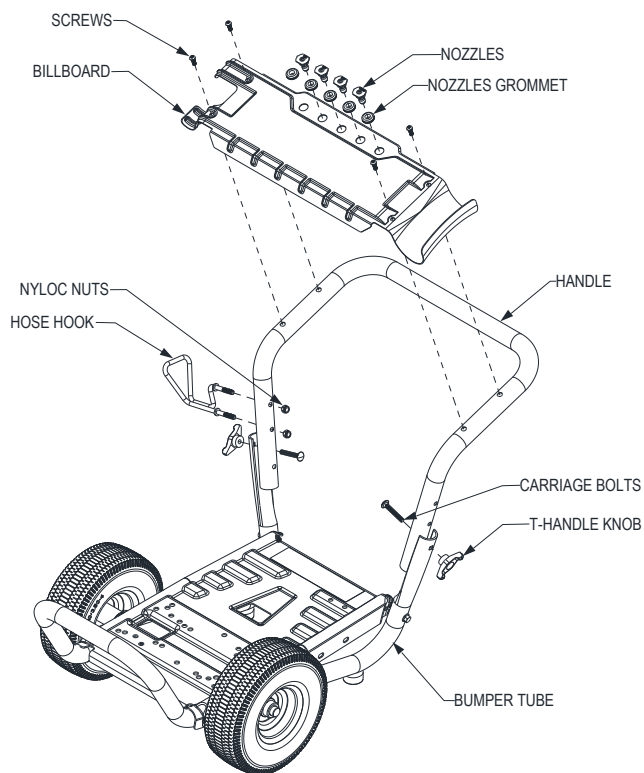

Fig1571101_5

Spray Gun Assembly

Attach the Lance to Spray Gun

Tighten spin-on coupler hand tight.

Note: The O-rings create a seal so there is no need to tighten with a wrench.

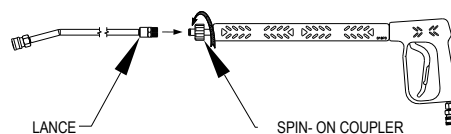

Replace Shipping Plug

Remove non-vented shipping plug from the pump and add vented plug.

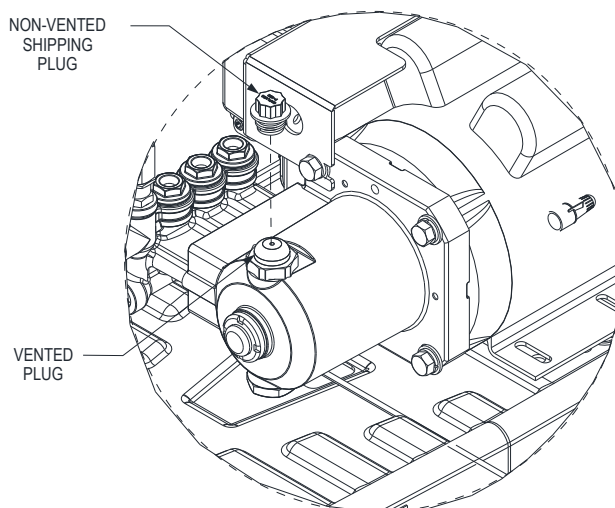

Fig.1571101_15

Initial Set-up

Step 3. Select Suitable Location

Moving and Handling

 **WARNING**

Lifting Hazard

The pressure washer is heavy. It can crush and cause serious injury if it rolls out of control or tips over. Follow the instructions below for safely moving the pressure washer.

Moving your pressure washer around

- Use the handles to manually move the pressure washer.
- Push the pressure washer in front of you as you walk.
- To turn, push down slightly on the handles and pivot the pressure washer on its wheels.

Elevating or lowering your pressure washer

- To reduce risk of injury, it is recommended that two adults lift the pressure washer.
- Only lift the pressure washer by the bumper and Handle. Do not use the pump or motor as lifting point. See component identification for lifting point locations.

Positioning:

1. The pressure washer should be positioned on a firm, level (less than 3-degree slope), heat-resistant surface with good drainage and a nearby water supply.
2. The pressure washer should be placed within garden hose distance of a continuous water supply. Ensure that the pressure washer sits level and will not slide or shift during operation. If applicable, block the pressure washer's wheels to prevent movement.

Airflow:

1. Situate so there is adequate clearance around pressure washer to allow for airflow – at least 7 feet from any non-combustible wall or obstruction.
2. Do not operate with a tarp, blanket, or cover surrounding the pressure washer.
3. Do not place any objects against or on top of the pressure washer.

4. The pressure washer needs adequate, unobstructed flow of air to allow for adequate cooling. Cooling ventilation is required to prevent overheating of the pressure washer and possible fire.
5. Keep a fire extinguisher rated “ABC” nearby.

Step 4. Verify Electrical Connection

Grounding

Product must be grounded. The supply cord is equipped with an equipment-grounding conductor and a grounding plug. This plug must be plugged into an outlet that is properly installed and grounded in accordance with all local codes and ordinances.

Ground Fault Circuit Interrupter Protection

Connecting the pressure washer through some type of ground fault circuit interrupter (GFCI) protector is required to comply with the National Electric Code (NFPA 70) and to provide additional protection from the risk of electric shock.

Note: Before use, your GFCI should be tested at either built-in or receptacle base.

1. This Product is provided with a ground fault circuit interrupter built into the power cord or plug. If replacement of the ground fault circuit interrupter or cord is needed, use only identical replacement parts

 **DANGER: Electrocution hazard**

Improper connection of the equipment or grounding conductor can result in a risk of electrocution. Check with qualified electrician or service personnel if you are in doubt as to whether an outlet is properly grounded. Do not modify the plug provided with the product. If it will not fit the outlet, have a proper outlet installed by a qualified electrician. Do not use any type adapter with this product.

Initial Set-up

Extension Cord

This appliance cord is equipped with a GFCI, do not use extension cords. If the appliance cord is not equipped with a GFCI, the appliance and any extension cord used should be connected only to a GFCI-protected power source.

1. Use only extension cords that have grounding-type plugs and female cord connectors that accept the plug from the product.
2. Use only extension cords that are intended for outdoor use. These extension cords are identified on the packaging or on the cord by a marking "Acceptable for use with outdoor appliances; store indoors while not in use."
3. Use only extension cords having an electrical rating not less than the rating of the product.
4. Do not use a damaged extension cord. Examine extension cord before using and replace if damaged.
5. Do not abuse extension cord and do not yank on a cord to disconnect.
6. Keep cord away from heat and sharp edges.
7. Always disconnect the extension cord from the receptacle before disconnecting the product from the extension cord.



WARNING

To reduce the risk of electrocution, use only a GFCI-protected extension cord or plug into GFCI outlet. Keep all connections dry and off the ground. Do not touch plug with wet hands.

Operation

Follow Safety Rules for Operation

After you have checked the equipment and positioned it in a suitable worksite, it is time to start your pressure washer. The following are the procedures necessary for safe, successful operation of your pressure washer.



WARNING

Failure to follow safety rules may result in serious injury or death to the operator or bystanders.

Instruct Operators. Owner must instruct all operators in safe set-up and operation. Do not allow anyone to operate the pressure washer who has not read the Owner's Manual and been instructed on safe use practices.

Safety Equipment/Controls. Always operate with all safety covers, guards, and barriers in place and in good working order, and all controls properly adjusted for safe operation.

Moving Parts. Keep hands, feet, hair, and apparel away from moving parts. Air vents may cover moving parts and should be avoided as well. Never remove any guards while the pressure washer is operating.

Ear Protection. Hearing can be damaged from prolonged, close-range exposure to the type of noise produced by this pressure washer. The use of ear plugs or other hearing protection devices is recommended for persons working within 15-20 feet of the running pressure washer for an extended period of time.

Eye Protection. Wear ANSI "Z87.1" required safety glasses when operating or servicing the pressure washer. Pressurized spray from this pressure washer can cause severe injury to the eyes. Small objects can become airborne as the spray contacts them.

NOTE!

Before starting the pressure washer, review the following general safety rules for operation:

Conditions for Use

Know How to Stop. Be thoroughly familiar with proper use of the equipment and all controls and connections. Know how to stop the pressure washer and depressurize the system quickly if needed.

Instruct All Operators. The pressure washer's owner must instruct all operators and potential renters in safe

set-up and operation. Do not allow anyone to operate the pressure washer who has not read the Owner's Manual and been instructed on its safe use.

Adult Control only. Only trained adults should set up and operate the pressure washer. Do not let children operate. Pressure washers can generate forces greater than children can control and require judgment beyond what can be expected of children.

Under the Influence. Never operate, or let anyone else operate, the pressure washer while fatigued or under the influence of alcohol, drugs, or medication.

Safety Equipment / Controls in place. Do not operate the pressure washer unless all safety covers, guards, and barriers are in place and in good working order, and all controls are properly adjusted for safe operation.

Damaged. Do not operate the pressure washer with damaged, missing, or broken parts. Never attempt to repair a high-pressure hose or component. Always replace it with a part that is rated at or above the pressure rating of the pressure washer.

Modifications. Do not modify the pressure washer in any way or deactivate any safety device. Fire, explosion, or other serious safety hazards will also void the warranty.

During Use

Stay alert. Watch what you are doing at all times.

Clear work area. Clear the work area of all bystanders.

Keep children and pets away.

Keep spray away from electrical wiring. Spray contact with electrical wiring will likely result in severe electrical shock or electrocution.

Do not point gun at people or animal. It may result in serious injury or death.

Do not direct spray at this pressure washer. Do not attempt to clean this pressure washer with its own spray. Motor damage will result. Cleaning should be done with a damp sponge with the motor OFF.

Operation

Never pull by hose. Do not move this pressure washer by pulling on the hose. Hose or connections could fail and result in catastrophic high-pressure release of fluid as well as hose whipping.

Avoid sharp objects. Keep hose away from sharp objects. Bursting hoses may cause injury.

No load bearing. Do not use the pump to support other items of equipment that impose unacceptable loads on the pump. Do not attempt to use this pressure washer as a prop.

Lock trigger safety latch when not spraying. Spray gun is equipped with a built-in trigger safety latch to guard against accidental trigger release. Rotate safety latch to the locked position when not spraying.

Leaving unattended. Always turn off the pressure washer and relieve system pressure before leaving the sprayer unattended.

Prompt Emergency Response

Seek medical aid for suspected injection injury. If injured by high-pressure fluid, no matter how small the wound is, see a doctor at once. A typical injection injury may be a small puncture wound that does not look serious. However, severe infection or reaction can result if proper medical treatment is not administered immediately by a doctor who is familiar with injection injuries.

Wear Personal Protective Gear

WARNING

Wear personal protective gear to prevent:

- Eye and skin injection injury from high pressure spray
- Eye injury from flying debris

1. Wear waterproof gloves, ANSI Z87.1 compliant safety goggles, face protection, and protective clothing when operating the pressure washer. If spraying pressure washer specific chemicals, wear a respirator mask to avoid inhalation of vapors if directed on the chemical label.
2. Wear non-slip, protective footwear. Use of pressure washer can create puddles and slippery surfaces. Wear footwear capable of maintaining a good grip on wet surfaces.

Preparing for Operation

Make sure that any regular maintenance has been performed as prescribed in “*Maintenance & Repair*” section.

Check/Add Oil to Pump

1. Remove shipping plug and install vented fill cap

CAUTION		
Pump	Model	Oil Type
GP EVO	1571101	SAE 30 Non-Detergent Oil or Pressure washer Pump Oil (Part# 4043)
GP EP1812	1571104	
GP EP1812	1571105	SAE 30 Non-Detergent Oil or Cat Pump Oil part # 22158
CAT 4DX	1571102	
CAT 4DNX	1571103	

Never run the pump without sufficient lubrication!

2. Check oil level. Verify that oil level is halfway up the sight glass.
3. If oil level is low, use the oil type from above table.

Operation

Inspect Spray System

Always inspect spray system for damage and leaks before each use. Do not start pressure washer until all needed repairs have been completed.

⚠ WARNING

High Pressure Fluid Injection Hazard

High-pressure fluid discharge from leaks (even pin-sized) or ruptured components can pierce skin and inject fluid into the body. Injection injury can result in blood poisoning and/or severe tissue damage leading to infection, gangrene, and possibly amputation.

- Never use a finger or skin to check for leaks.
- Never operate pressure washer with damaged or missing hoses/parts.
- Never attempt to repair a high-pressure hose or component – Always replace it with a part that is rated at or above the pressure rating of this pressure washer.

Perform Scheduled Maintenance, As needed

Make sure that any other regular maintenance has been performed as prescribed in this manual in the "Maintenance Schedule Summary" section. Refer to the motor maintenance instructions.

Connect Hoses, Water Supply, and Spray Nozzle

Position Pressure Washer for Use

- For detailed instruction on positioning your pressure washer for use, turn to the "Initial Set-Up" section of this manual and reference "Step 3: Select Suitable Location".
- Where no flammable vapors, dusts, and gases are present.
- Where there is adequate, unobstructed ventilation airflow.
- With adequate clearance from combustible materials.
- On a firm, level, heat-resistant surface with good drainage and nearby access to a continuous water supply.

Attach Garden Hose to Water Inlet

1. Make sure the water supply is clean. Debris can cause excess pump wear and reduce performance.
2. An insufficient water supply will damage your pump. Make sure the water supply is steady and is 20% over the rated flow of your pump. Use a stopwatch to time how long it takes to fill a 5-gallon bucket with

your garden hose. The bucket must fill faster than the times listed in the table below.

Model#	Time to Fill 5 Gallon Bucket
1571101, 1571102	160 sec
1571103	100 sec
1571104, 1571105	60 sec

3. The water supply garden hose must have an inside diameter of at least 5/8". If the hose is more than 100 ft. long, the diameter must be at least 3/4".
4. Never use a reservoir tank as a water source. Drawing water out of a tank may cause pump cavitation and damage to your pump. This pressure washer is designed for a pressurized water source such as a city water faucet. However, the water source pressure must not exceed:

Model#	Max. Inlet psi
1571101	45 psi
1571102, 1571103	60 psi
1571104, 1571105	125 psi

5. Always use a flexible rubber hose for your water supply. Do not use rigid piping.

Attach High Pressure Hose to Spray Gun and Water Outlet

⚠ WARNING

High Pressure

NEVER operate this pump with components (such as hose, connections, and spray gun) rated for lower pressure and/or temperature limits than the pressure washer's maximum rated pressure and temperature, or component could rupture and cause serious personal injury from escaping high pressure fluids.

1. See "Component Identification" section of this manual for location of the pressure washer's water outlet.
2. Your pressure washer hose is equipped with quick couplers. Simply pull the collar back and push the coupler onto the water outlet nipple. The collar should slide over the ball bearings

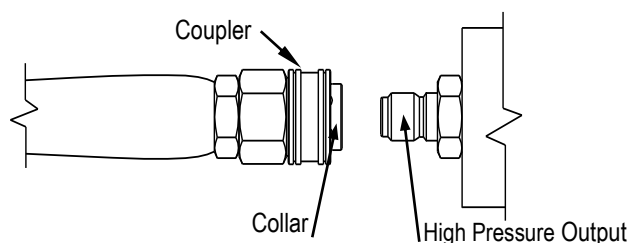

Operation

- Release the collar, making sure it springs back and re-seats to its original (non-retracted) position. *Check the connection by pulling on the hose to ensure a positive connection.*

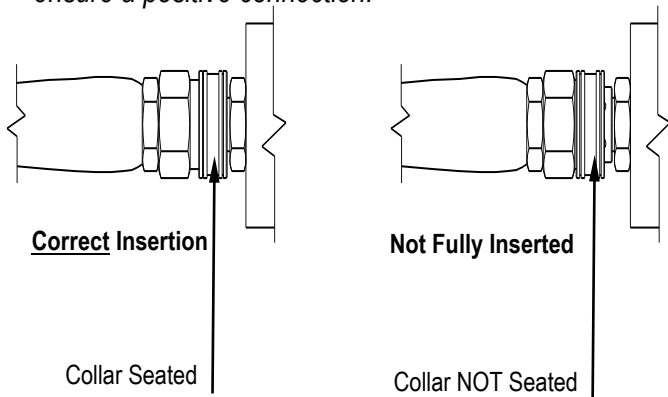

Select Nozzle for Spray Gun

Your pressure washer is equipped with high-pressure nozzles and one low-pressure nozzle. Additional nozzles can be purchased by following the Nozzle Orifice size in the specification. Generally, the wider the spray angle of the nozzle, the lower the spray impact produced. Select the appropriate nozzle for the job based on the following table:

Color of Nozzle:	Spray Angle	Used For
Yellow	15	Tough Stains/Stripping
Green	25	General
White	40	Light Cleaning
Black (Low Pressure)	65	Chemicals

NOTE: You must use the low-pressure black nozzle for spraying chemicals.

Attach Nozzle to Spray Gun

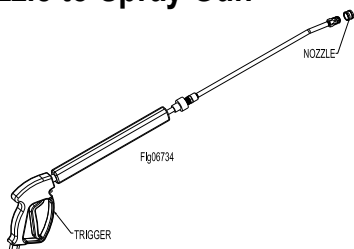

! WARNING

Depressurize First

Any time you remove/install/change a nozzle, you must depressurize hose line by squeezing the spray gun trigger while the motor is off. Even if the motor has been off for a long period of time, the hose may remain dangerously pressurized.

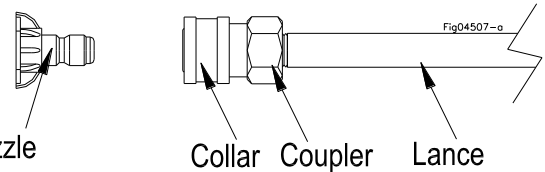

- Make sure the motor is off and the hose line is depressurized.
- To install the nozzle, pull the collar back and twist the nozzle firmly into the coupler on the end of the wand.
- Release the collar, making sure it springs back and re-seats to its original (non-retracted) position. *Check the connection by pulling on the nozzle to ensure a tight connection -- if correctly inserted, nozzle will rotate but not pull out.*

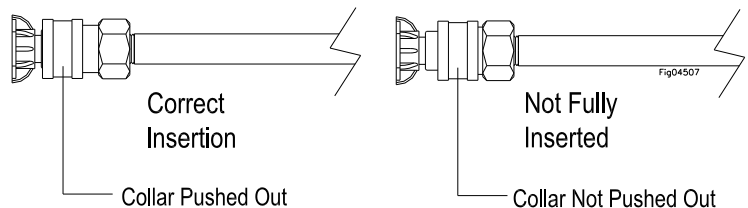

Prime the Water Supply

Turn On Water Supply and Squeeze the Trigger

CAUTION: Water Pressure

Never run the pump without the water supply connected and turned on. Operating the pressure washer without sufficient incoming flow of water will damage the pump.

- Turn on the water supply. Make sure the water supply is steady and flowing at a rate 20% over the rated flow of your pump. (Reference the flow rate table under the "Connect Hoses, Water Supply, and Nozzle" section.)
Purge air from the water supply hose by squeezing the trigger until a steady stream of water flows out of the nozzle at low pressure. (Air in the hoses can cause damage to the pump, so always make sure all the air is out of the hoses before starting the pressure washer motor.)
- Make sure the water supply hose is not kinked. A kinked hose will provide insufficient water supply to the pump and reduce its life. Make sure the hose remains unkinked after moving the pressure washer.

Operation

Set Up for Chemical Spray (if desired)

Prepare for Chemical Spray (if planning to use)

Using the proper cleaning chemical for the application can speed up cleaning jobs tremendously.

Your pressure washer is equipped with a chemical injection point on the downstream side of the pump for introducing cleaning chemicals into the water stream. A braided chemical hose is provided to connect at this point. Suction pressure at this connection automatically draws the chemical solution in through the hose, mixing in 1-part chemical to 15 parts water. Adequate suction pressure is created only when the low pressure (black) spray nozzle is used.

The introduction of cleaning chemicals via the chemical injection point affords the following advantages:

- It protects the pump from damage because no chemical passes through the pump.
- It mixes the cleaning chemical into a low-pressure spray. Cleaning chemicals applied under low pressure adhere better to the surface being cleaned, allowing the formula time to react and remove dirt more effectively.

Note: An external *upstream chemical injector* is not recommended for use with this pressure washer, and if used would obviously alter the 15-to-1 dilution ratio and may cause pump damage.

CAUTION

Chemicals Containing Muriatic Acid

Certain chemicals, such as bleach or those containing muriatic acid, will cause pump damage if introduced upstream through the pump's water inlet. Use of chemicals not intended for pressure washers will void pump warranty.

⚠ WARNING

Chemical Spraying

- Never spray acids, corrosives, or abrasive or flammable liquids. Breathing hazards, surface burns/corrosion, or fire/explosion could result.
- Follow the chemical manufacturer's label instructions for proper use and handling of the chemical. Understand all safety hazards and first aid for all chemicals being used. Always wear protective gloves when handling and cleaning with chemicals, and wear other protective gear as directed by chemical manufacturer. Always dispose of hazardous fluids per local, state, and national guidelines.

Acquire Cleaning Chemical

Use only approved pressure washer chemicals or chemicals specifically formulated for use with pressure washers.

CAUTION

Non-approved Chemicals

Non-approved chemicals can damage pressure washer components (seals, wand, hoses, pump, etc.) and be harmful to the environment.

Prepare for Chemical Spray (If Planning to Use)

Prepare the pressure washer for chemical spraying using the following steps:

1. Prepare (dilute) chemical cleaning solution as required for the job.

Note: the chemical solution will be automatically mixed with the water at a ratio of 15 parts water to 1-part chemical solution.

2. Press the braided chemical hose over the chemical injector on the pump.
3. Submerge the suction strainer connected to the braided chemical hose into a bucket containing the chemical solution.

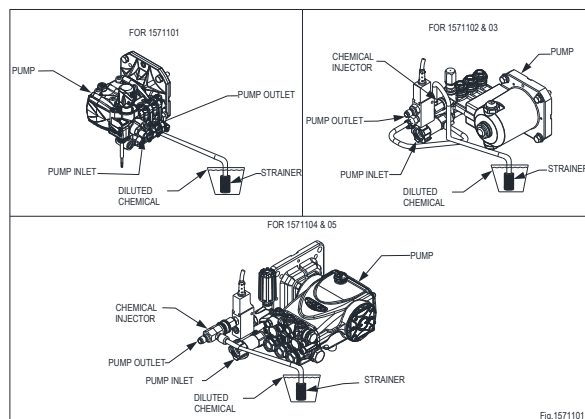

Fig. 1571101_6

Operation

Start-Up Procedures

Start the Motor to Power the Pump

1. Make sure water supply is connected and primed.

CAUTION

Warranty Void

Running the pump dry will cause damage and void the warranty.

2. To prevent accidental spraying, engage the safety latch on spray gun trigger by rotating it to the locked position.

Apply Cleaning Chemical (if desired)

1. Make sure the chemical injector is properly set up according to the instructions. Reference “*Set Up for Chemical Spray*” on the previous page.
2. Make sure the low-pressure BLACK nozzle is attached before beginning to spray chemicals. *Only the low-pressure black nozzle will allow chemicals to be drawn through the chemical injector into the water stream.*
3. Apply chemicals by squeezing the spray gun trigger. The chemical injector will draw the chemical into the water stream.
4. Apply chemicals evenly to the cleaning surface. Never use more chemical than is necessary to clean the surface.
5. Allow the chemicals time to react with the dirt before rinsing.
6. Prepare to rinse by changing to a high-pressure nozzle. Changing the nozzle from the low-pressure black nozzle to a high-pressure nozzle will stop the flow of chemicals into the water stream.

Instructions for selecting a nozzle can be referenced in the “*Connect Hoses, Water Supply, and Spray Nozzle*” section. See the subsection “*Select Nozzle for Spray Gun*”.

7. Rinse with high-pressure spray as instructed below:

Begin High Pressure Spray

⚠ WARNING

High - Pressure Spraying Safety

- **Keep spray away from people.** Never direct discharge stream at or near any person. Do not allow any part of the body to come in contact with the fluid stream. High-pressure spray can cause serious skin, eye, or falling injuries. Injection injury will occur if high-pressure spray pierces the skin, injecting liquid under the skin. Injection injury can result in blood poisoning and/or severe tissue damage leading to infection, gangrene and possibly amputation. Seek medical attention.
- **Do not secure trigger open.** To reduce risk of injury, do not attempt to secure the spray gun open by blocking or tying the spray gun in the open position.
- **Prevent slips / loss of balance.** High-pressure spray could cause you to lose balance from kickback forces, and wet surfaces can be slippery.
 - Keep good footing and balance at all times. Do not overreach.
 - Do not stand on unstable support when spraying.
 - If spraying from an elevated surface, use fall protection because spray gun kickback can propel you off the elevated surface. When spraying from a ladder or scaffolding, ensure it is firmly anchored from sway or tip-over.
 - Be aware of puddles and slippery surfaces. Ensure there is adequate drainage to prevent pooling of water.
- **Prevent surface damage & flying debris.** Surfaces being sprayed must be strong enough to withstand high-pressure spray or damage may result. In addition, high-pressure spray will dislodge unsecured objects as well as surface chips and debris, resulting in hazardous flying objects that can cause personal injury or property damage. Do not spray brittle surfaces or breakable, fragile, or unsecured objects such as:
 - stucco or laminar flagstone
 - some painted surfaces
 - windows or glass doors, or mailboxes they may break)
 - light fixtures, flowerbeds, mailboxes
 - unsecured, lightweight objects

Operation

Procedure:

1. Install the high-pressure spray nozzle (always relieve system pressure first and follow instructions for attaching a nozzle).

! WARNING

High Pressure Spray Hazard

- High pressure spray can cause injection injury, eye injury, and loss of balance. Serious injury could result from unintentional release of high-pressure spray from the gun upon engaging the trigger.
- ALWAYS turn Power Switch to OFF position and relieve system pressure when leaving pressure washer unattended.
- Total Start/Stop feature allows temporary motor shut-off (STOP) when the Trigger is disengaged and allows motor turn-on (START) when the Trigger is reengaged. This Feature should NEVER be used to shut-off the pressure washer when not in use.

2. Clear the cleaning area of all persons. Keep children and pets away.
3. Hold the spray gun firmly with two hands and a sturdy stance -- Gun kicks back when triggered.
4. Wash from the bottom to the top, using side-to-side motions. This washes away heavy dirt and allows the detergent to soak as you work toward the top.
5. Use the width of the spray pattern to wash a wide path. Overlap spray paths for complete coverage.
6. The nozzle should be 12" to 24" from the work, closer for tough areas.
7. Small parts should be washed in a basket, so the pressure does not push them away. Larger, lightweight parts should be clamped down.
8. The pressure washer is set and locked to the maximum rated pressure when it leaves the factory.

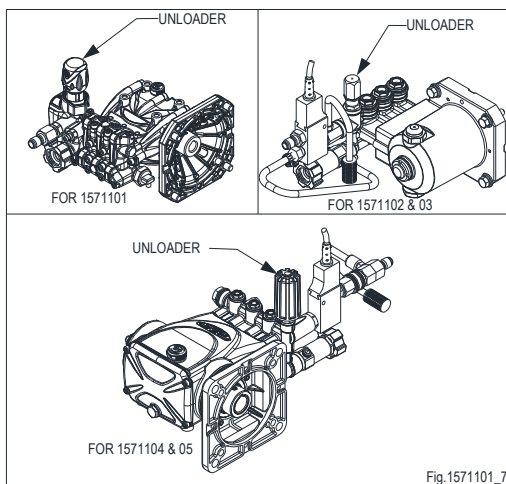

Fig.1571101_7

To reduce the pressure, turn the unloader knob counterclockwise. To return to maximum pressure turn knob clockwise.

9. If temporarily interrupting spraying, rotate trigger safety latch downward to the locked position to guard against accidental trigger release.

! WARNING

Warranty Void

Do not attempt to alter the unloader valve's maximum pressure. Excess pressure could cause serious injury from escaping high-pressure fluids and/or pump damage. Any alteration other than turning the adjustment knob will void your warranty.

Spray Gun Safety Lock

When not spraying, use the spray gun safety lock to prevent accidental high-pressure discharge.

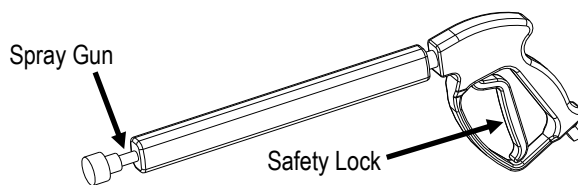

10. Always turn off the motor and activate spray gun trigger to relieve system pressure when:
 - the sprayer is unattended, or
 - disconnecting hoses, installing/cleaning nozzles, or servicing the pump.

! WARNING

Injury

Always turn off the motor and relieve system pressure when finished spraying or when leaving sprayer unattended. Serious injury could result from unintentional release of high-pressure spray.

Shutdown

! WARNING

Injury

Never disconnect the high-pressure hose from the pump or spray gun while the system is pressurized. Relieve pressure by squeezing the spray gun trigger after the motor is turned OFF.

Stop the motor using the following steps:

1. Turn motor OFF.
2. Unplug the power cord.
3. Turn water supply OFF.
4. Squeeze trigger to relieve system pressure.
5. Remove garden hose.
6. Remove pressure hose.

Storage

When you are finished using the pressure washer, you must prepare the pressure washer for storage and store it in a proper location.

Between Use Storage

Perform periodic maintenance as directed in this manual to keep the pressure washer in safe working condition.

Choose a storage location that is:

- Clean and dry.
- Away from sources of heat, open flames, sparks, or pilot lights, even if the pressure washer's motor is off.

Away from extreme high or low temperatures. Do not store the pressure washer in freezing conditions unless it is prepared as directed below for those conditions.

Note:

- **If you will be storing the pressure washer in freezing conditions**, follow the instructions for preparing the sprayer for storage in freezing conditions.
- **If you will not be using the pressure washer again for 30 days or more**, follow the instructions for preparing for long-term storage.

Prepare Pressure Washer for Freezing Conditions

If you will be storing the pressure washer in freezing temperatures, you must properly prepare the pressure washer to prevent water from freezing in the system.

WARNING

Freezing Conditions

Do not allow water to freeze in the pressure washer, high pressure hose, or spray gun. Freezing water can cause damage to the equipment and cause the spray gun to fail in the open position. A spray gun that has failed in the open position can whip around and cause personal injury when the pressure washer is started.

1. Drain the water from the high-pressure hose and spray gun by depressing the trigger on the spray gun until all water drains out.
2. Disconnect the plumbing that connects to the pump outlet.
 1. Obtain the materials you will need:
 - 1579000 NorthStar Pressure Washer Pump Freeze Guard.
 2. Attach bottle of freeze guard to pump inlet.
 3. Squeeze freeze guard bottle until antifreeze comes out of the pump outlet.

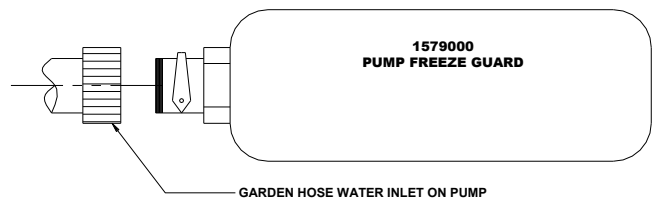

Prepare Pressure Washer for Storage

1. Make sure the motor start switch is OFF.
2. Disconnect the motor power cord if you haven't already done so.
3. Disconnect the high-pressure hose, garden hose, and spray gun.

Move Pressure Washer to Storage Location

Let motor cool for 5 minutes before moving the pressure washer to its storage location.

Maintenance & Repair

WARNING

Maintenance Hazards

ALWAYS shut off water supply, bleed water pressure, and turn off motor before cleaning, adjusting, or servicing the pressure washer. After servicing, make sure all guards and cover shields are replaced before using.

Maintenance Schedule Summary

Item	Frequency
Remove dust/debris accumulation	As needed
Inspect spray system	Each use
Clean inlet filter	Each use
Check pump oil level	Each use
Change pump oil	<ul style="list-style-type: none">• After first 50 hours of use• Every 3 months or 500 hours of use after that

See detailed instructions for each maintenance item below.

(Note: For end-of-the-season storage instructions, see the "Storage" section of this manual.)

Detailed Instructions – Maintenance & Repair

No modifications. Never modify or alter the pressure washer in any way. Modifications can create serious safety hazards and will also void the warranty.

Follow Safety Rules

Read and follow these safety rules whenever you will be servicing the pressure washer:

- **Turn off / relieve pressure first.** Always turn off pressure washer and relieve system pressure before inspection or maintenance.
- **Replace guards.** Make sure all guards and cover shields are replaced after servicing the pressure washer.
- **Major repair.** Major service, including the installation or replacement of parts, should be performed only by a qualified service technician. Obtain factory approved parts from NorthStar Product Support at 1-800-270-0810.
- **Replacement parts.** If a part needs replacement, only use factory approved repair parts. Replacement parts that do not meet specifications may result in a safety hazard or poor operation of the pressure washer and will void the warranty.

Keep Pressure Washer Clean

If dust or debris accumulates on the pressure washer, clean the pressure washer with a damp cloth or soft bristle brush. Do not allow air intakes to become blocked.

CAUTION

Do not spray pressure washer with a garden hose or pressure washer. Water may enter the pressure washer and cause damage.

Inspect Spray System

Inspect spray system for damage and leaks before each use.

Do not start pressure washer until all needed repairs have been completed.

Maintenance & Repair

⚠ WARNING

High Pressure Fluid Injection Hazard

High pressure fluid discharge from leaks (even pin-sized) or ruptured components can pierce skin and inject fluid into the body. Injection injury can result in blood poisoning and/or severe tissue damage leading to infection, gangrene, and possibly amputation.

- Never use a finger or skin to check for leaks.
- Never operate pressure washer with damaged or missing hoses/parts.
- Never attempt to repair a high-pressure hose or component – Always replace it with a part that is rated at or above the pressure rating of this pressure washer.
- Check hoses, fittings, wand, trigger gun and connections for signs of wear, cracks, looseness, or leaks. Replace as required.
- Check and clean the nozzle orifice.

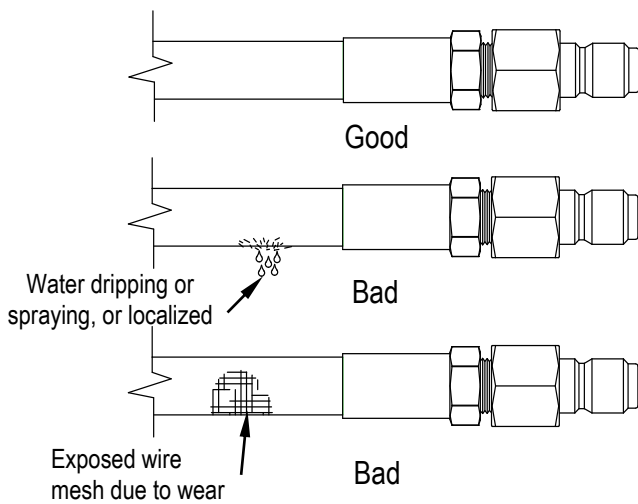

Clean Inlet Filter

Clean the inlet filter before each use.

⚠ WARNING

Filter Disposal

When cleaning filters, check whether dangerous chemicals have been used with the filter and take any precautions that may be recommended by the manufacturer of these chemicals. Always dispose of hazardous fluids per local, state, and national guidelines.

1. Unscrew garden hose from water inlet (if connected).
2. Unscrew inlet filter.
3. Remove filter screen.
4. Run water through filter screen to clean.
5. Reassemble.

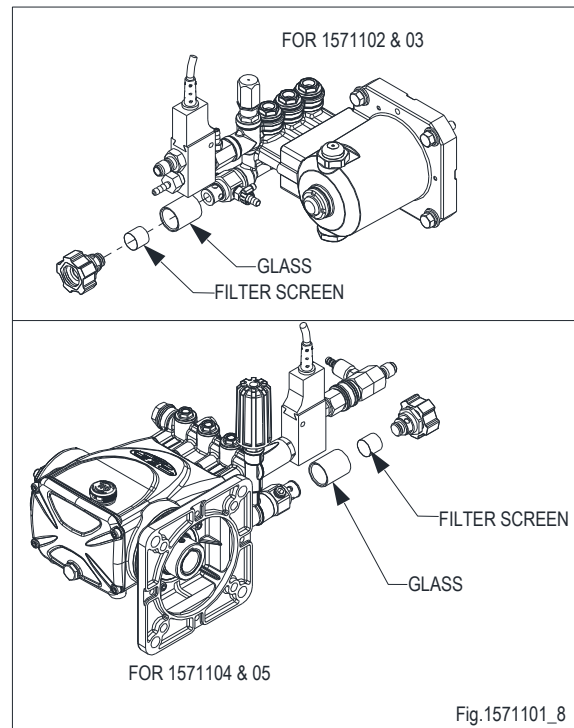

Do not start pressure washer until all needed repairs have been completed.

Maintenance & Repair

Change Pump Oil

Change the pump oil after the first 50 hours of use, and then after every 3 months or 500 hours of use after that.

1. Remove drain plug from pump.
2. Drain pump oil into suitable container and dispose of responsibly.
3. Reinstall oil drain plug.
4. Make sure pressure washer is sitting level.
5. Reference the "Specifications" section of this manual to determine the oil type and quantity needed for your pump model.

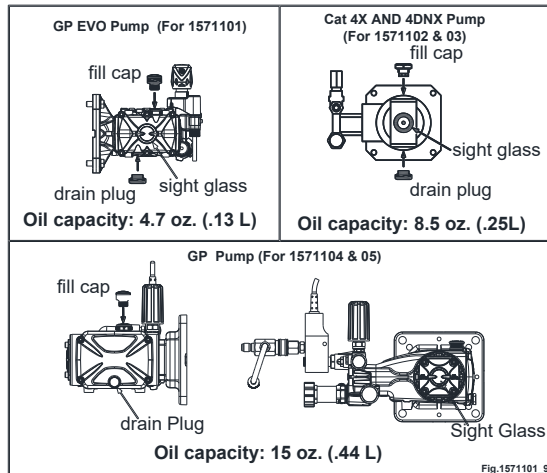

6. Replace oil fill cap

NOTICE:

Dispose of used motor and pump oil in a manner that is compatible with the environment and in accordance with local, state, and federal laws and regulations.

- Take used oil in a sealed container to your local recycling center or service station for reclamation.
- Do not throw it in the trash, pour it on the ground, or pour it down a drain.

NOTE TO COMMERCIAL USERS:

All mechanical equipment, no matter how well designed, will need maintenance and repairs. A NorthStar pressure washer is no exception. At times, a NorthStar pressure washer may become inoperable because repairs are required. NorthStar Product Support will assist in these repairs as needed, but if an inoperable

pressure washer creates a major expense to your business, then we strongly recommend the following:

- Have a staff person become familiar with the mechanical operation of the pressure washer and capable of making minor repairs and performing all preventative maintenance procedures.
- Keep a stock of recommended service parts for maintenance and minor repairs.

IMPORTANT: Replacement Parts

If a part needs replacement, only use parts that meet the manufacturer's part number specifications. Replacement parts that do not meet specifications may result in a safety hazard or poor operation of the pressure washer.

Contact NorthStar Product Support at
1-800-270-0810 for any
questions, problems, or parts orders.

Troubleshooting

The manufacturer reserves the right to make improvements in design and/or changes in specifications at any time without incurring any obligation to install them on units previously sold.

Problem	Solution
Motor will not start	SOLUTION: A, B, M, N, O
Low/Surging pressure or no water flow	SOLUTION: C, D, E, F, G, H
No chemical injection	SOLUTION: I, J, K, L
Cause	Solution
A- Tripped GFCI cord	Reset GFCI cord
B- Tripped motor relay	Reset motor
C- Insufficient water supply	See water supply section of this manual
D- Plugged pump inlet filter	See maintenance section of this manual
E- Wrong nozzle	Make sure high-pressure nozzle is being used
F- Plugged nozzle	Remove nozzle, check for blockage
G- Worn nozzle	Replace nozzle
H- Leak in pressure hose	Replace pressure hose
I- Wrong nozzle	Make sure chemical nozzle is being used
J- Back pressure from extra-long discharge hose	Try shorter hose
K- Leak in chemical siphon hose	Replace hose – use hose clamps if necessary
L- Chemical strainer not submerged	Make sure strainer is completely submerged
M- Tripped circuit breaker	Make sure breaker is rated to 120V/15A for 1571101 & 120V/20A for 1571102 only
	Make sure breaker is rated to 230V/30A for 1571103 & 1571104 and 230V/50A for 1571105 only
N- Extension cord too long	Use extension cord with an appropriate rating for distance
O- Debris in flow switch	Clean flow switch

Parts Explosion- Model #1571101

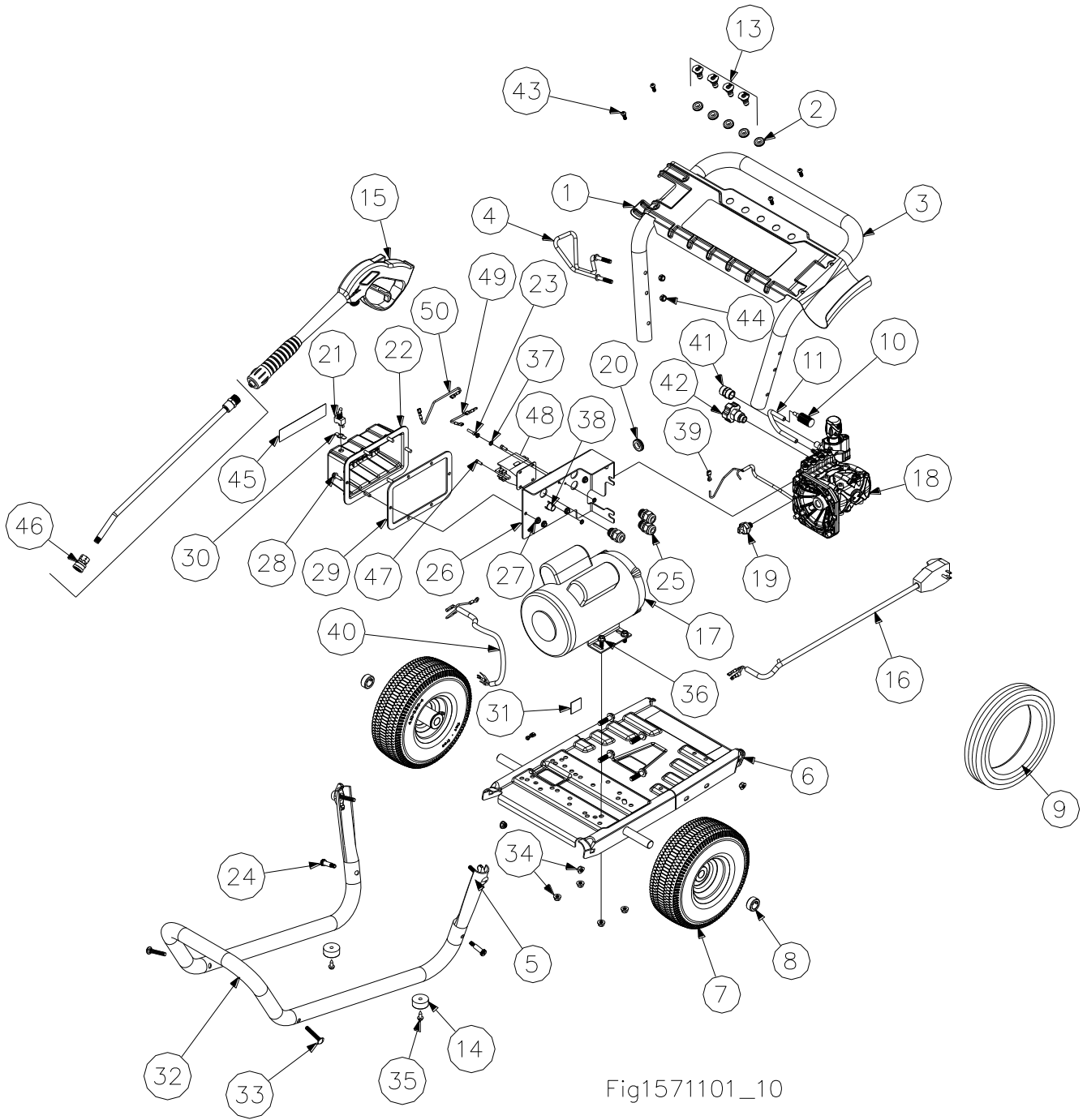

Fig1571101_10

Parts List - Model #1571101

REF#	PART#	DESCRIPTION	QTY
1	802173	Billboard with Decal	1
2	35198	7/16 ID Grommet	5
3	801578	Handle	1
4	779761	Hose/Cord Mount	1
5	38578	T-Handle Knob	2
6	803475	Base Weldment	1
7	800402	Tire Wheel Assembly	2
8	305200	Wheel Retainer	2
9	780841	1/4" x 25' Hose	1
10	221222	Chemical Strainer	1
11	805557	1/4" Braided Chemical Hose – 36"	1
12	803709	18.5" Lance	1
13	803898	Nozzle 4 pack #2.0	1
14	2215	Rubber Feet	2
15	38526	Gun, Consumer, QC	1
16	803214	GFCI Cord 120V/ 15A With Decal	1
17	802301	Motor-1.5HP-WEG-PW	1
18	A1571101	GP EVO Pump Assembly	1
19	35918	Thermal Protector	1
20	787403	Grommet, 5/8 ID SYM	1
21	777855	Toggle Switch	1
22	802781	Electric Control Box Cover	1
23	82007	SHCS, 10-32 X 3/4 YELLOW ZINC	1
24	87164	BOLT, 3/8x1 SHOULDER 5/16-18	2
25	22502	1/2" NPT STRAIN RELIEF	3
26	802858	1.5 HP Control Box Mounting	1
27	82013	Nut, 1/4-20 SER.FLG Z	6
28	82009	Bolt, 1/4-20 X 3/4 HHSF GR5Z	6
29	802782	Gasket	1
30	5260	On-Off Plate	1
31	801058	Decal, Made In USA	1
32	799956	Bumper Tube	1
33	82233	Carriage Bolt, 5/16"-18 X 2"	4
34	82630	Nut, 5/16-18 Nylon Lock Hex Flange	8
35	82232	Screw, Self Tap 1/4 X 3/4	2
36	82621	5/16"-18 x .75" Hex Head Flange Bolt	4
37	82008	Nut, 10-32 KEPS	4
38	35408	Nut, Wire Red – AC 459242	3
39	305276	Insulated Fem Spade	3
40	803067	Wire, Cord 14/3 AWG SJTW	1
41	803135	Fitting	1
42	803134	Filter, Inlet	1
43	87170	Bolt, 1/4-20 X 3/4" SHTS	4
44	777495	Nut, NYLOCK M8-1.25 ZINC - GN	2
45	802769	Decal, NS Branding Portable	1
46	791308	Nozzle Quick Coupler	1
47	82006	Screw, 10-32 X 1/2 SHCS Y/Z	2
48	778151	Contact, DP 120V/25A	1
49	778139	Wire Lead, White, PW	1
50	35383	Wire, 45924 Assembly (B2) -AC	1
51	800401	Billboard Decal	1

Parts Explosion- Model #1571102 & 03

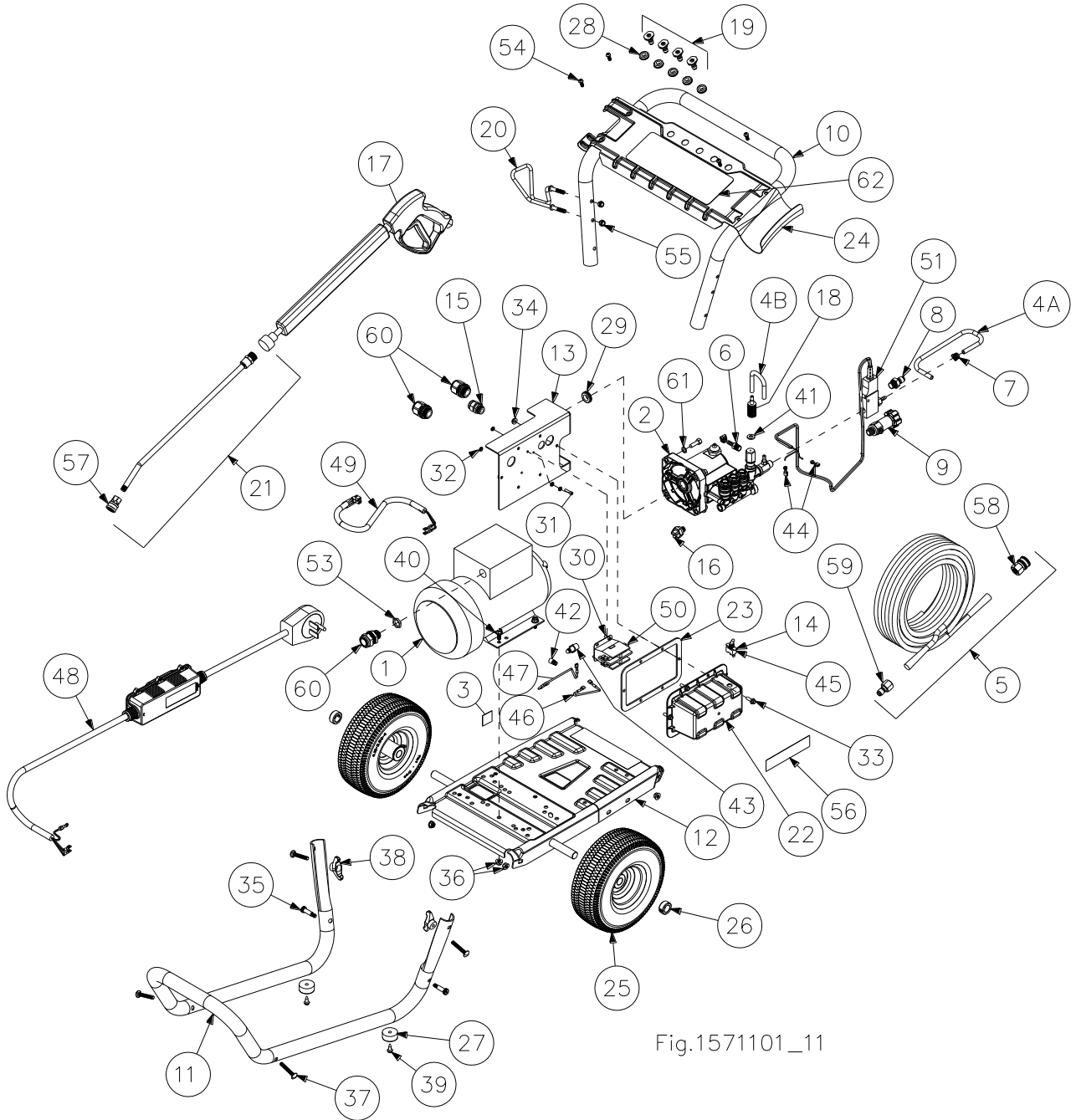

Fig.1571101_11

Parts List - Model #1571102 & 03

REF#	PART#	DESCRIPTION	QTY	MODEL#
1	803226	Motor, 2HP WEG, ODP 16.8A - PW	1	1571102
	803875	Motor, 5HP WEG, ODP-PW	1	1571103
2	A1573011	Cat 4DX Pump Assembly	1	1571102
	A1573021	Cat 4DNX Pump Assembly	1	1571103
3	801058	Decal, Made In USA	1	Both
4A	805555	Hose, 1/4" Braided Chemical – 14"	1	Both
4B	805557	Hose, 1/4" Braided Chemical – 36"	1	
5	800531	Hose Assy, 5/16X25' 4000PSI	1	Both
6	777340	Barb, Hose BR 1/4" MPT X 1/4"	1	Both
7	777834	Clamp, 1/4" Hose	2	Both
8	777913	Nipple, Male O.C. 3/8	1	Both
9	800985	Filter, Inlet, 3/8" NPT X 3/4" FGH	1	Both
10	801578	Handle-Tube- CWPW	1	Both
11	799956	Bumper-Tube- CWPW	1	Both
12	803475	Base Weldment Steel, CWPW	1	Both
13	802859	Plate, Control Bracket - CWPW	1	Both
14	5260	Plate, On-Off	1	Both
15	22502	Strain Relief	1	Both
16	35918	Protector, Thermal, 1/4 NPT	1	Both
17	38527	Gun, Consumer	1	Both
18	221222	Strainer, Chemical	1	Both
19	803898	Nozzle, 4 Pack #2.0 PW	1	1571102
	803862	Nozzle 4 Pack, #3.0 - PW	1	1571103
20	779761	Hose/Cord Mount-PW	1	Both
21	803709	Lance, 18.5" W/EPDM Coupler-PW	1	Both
22	802781	Control Box - CWPW	1	Both
23	802782	Gasket, Control Box - CWPW	1	Both
24	802173	Billboard With Decal, CWPW	1	Both
25	800402	Tire, 10" Welded	2	Both
26	305200	Retainer, Wheel - PW, TE	2	Both
27	2215	Bumper	2	Both
28	35198	Grommet, 7/16 ID-14GA-16A - PW	5	Both
29	787403	Grommet, 5/8 ID SYM - WP	1	Both
30	82006	Screw, 10-32 X 1/2 SHCS Y/Z	2	Both
31	82007	SHCS, 10-32 X 3/4 YELLOW ZINC	1	Both
32	82008	Nut, 10-32 KEPS (Price per 100)	4	Both
33	82009	Bolt, 1/4-20 X 3/4 HHSF GR5Z	6	Both
34	82013	Nut, 1/4-20 SER.FLG Z	6	Both
35	87164	Bolt, 3/8x1 Shoulder 5/16-18	2	Both
36	82630	5/16 Flange Nyloc Nut	8	Both
37	82233	Bolt, Carriage GR5Z 5/16-18X2PW	4	Both
38	38578	Knob, T-Handle - PW	2	Both
39	82232	Tapper, Self 1/4X3/4 TYPAB - PW	2	Both
40	82621	Bolt, 5/16 X .75 HHFB	4	Both
41	82047	Washer	1	1571102
42	5265	Nut, Wire	1	Both
43	35408	Nut, Wire Red - AC 459242	1	Both
44	305276	Insulated Fem Spade	2	Both
45	777855	Switch, Toggle	1	Both
46	778139	Wire Lead, White, PW	1	Both
47	35383	Wire, 45924 Assembly (B2) -AC	1	Both
48	803215	Cord, GFCI, 120V/20A, 36ft With Decal	1	1571102
	799485	Cord, GFCI, 240V, 10AWG, 36ft-PW	1	1571103
49	803477	12/3 AWG SJTW Motor Cord	1	1571102
	803071	Wire, Cord 10/3 AWG SJTW	1	1571103
50	778151	Contact, DP 120V/25A	1	1571102
	778152	Contact, DP 230V/30A	1	1571103

Parts List - Model #1571102 & 03

REF#	PART#	DESCRIPTION	QTY	MODEL#
51	802097	Switch, Flow 12GPM W/ PILOT	1	Both
52	-	-	-	-
54	87170	Bolt, 1/4-20 X 3/4" SHTS	4	Both
55	777495	Nut, Nylock M8-1.25 ZINC - GN	2	Both
56	802769	Decal, NS Branding Portable	1	Both
57	791308	Nozzle Quick Coupler	1	Both
58	777914	Hose Quick Coupler	1	Both
59	777915	Hose Quick Coupler Nipple	1	Both
60	803128	Strain Relief, 3/4" (.276-.511") - PW	2	1571102
	803129	Strain Relief, 3/4" (.492-.709") - PW	3	1571103
61	82049	M10 Rib Washer Z	4	Both
62	800401	Billboard Decal	1	Both

Parts Explosion - Model #1571104 & 05

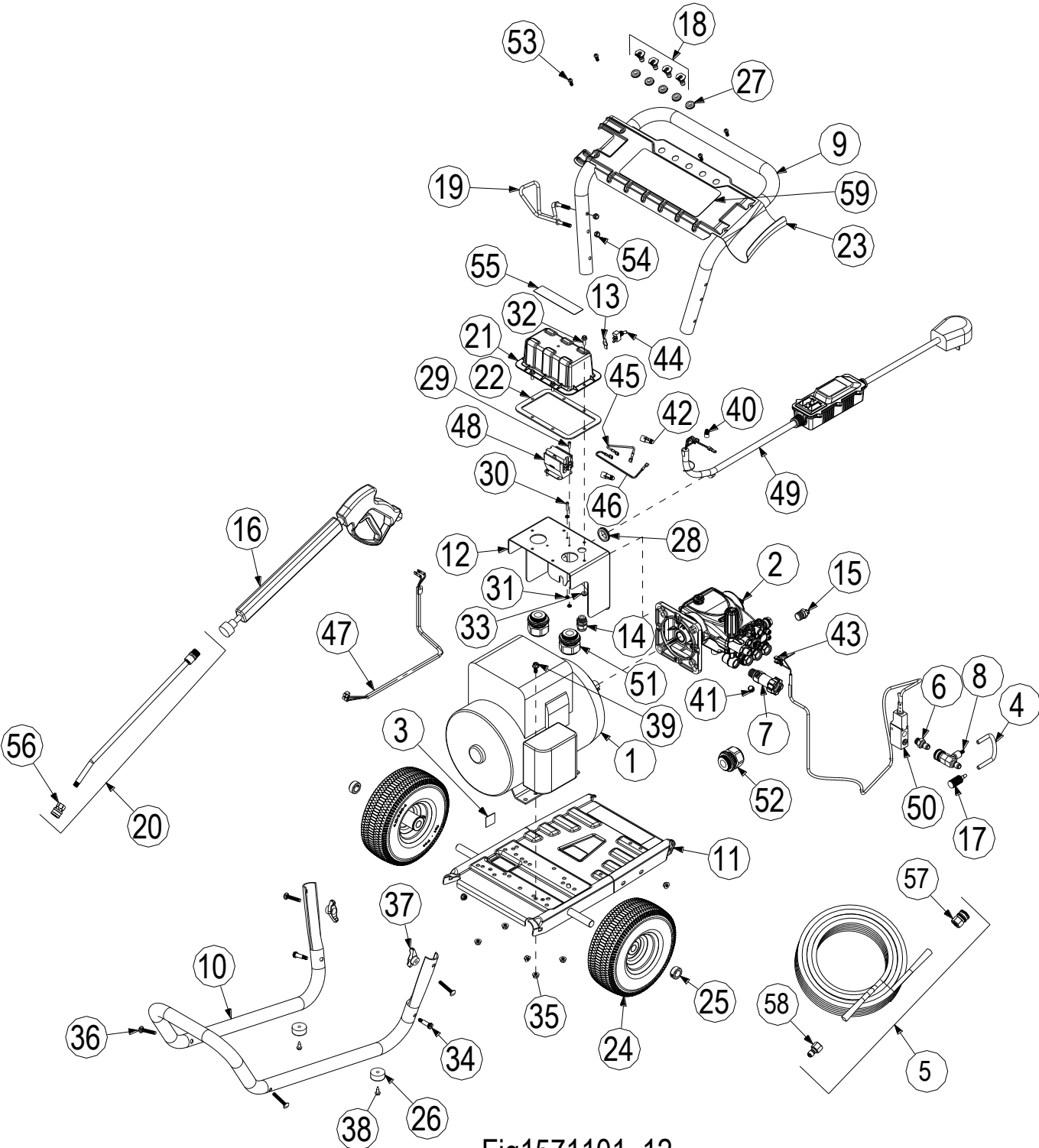

Fig1571101_12

Parts List - Model #1571104 & 05

REF#	PART#	DESCRIPTION	QTY	MODEL#
1	802780	Motor, 6.2HP WEG	1	1571104
	802877	Motor, 8.2HP WEG	1	1571105
2	A1571104	GP EP1812E17U-Pump Assembly	1	Both
3	801058	Decal, Made In USA	1	Both
4	805557	Hose,1/4" Braided Chemical – 36"	1	Both
5	800419	Hose Assy,3/8X50'4000PSI FLEX	1	Both
6	777913	Nipple, Male O.C. 3/8-PW	1	Both
7	800986	Filter, Inlet, 1/2" NPT X 3/4" FGH	1	Both
8	779613	Injector, Quick Connect 3GPM-PW	1	Both
9	801578	Handle-Tube- CWPW	1	Both
10	799956	Bumper-Tube- CWPW	1	Both
11	803475	Base Weldment Steel, CWPW	1	Both
12	802878	Plate, Control Bracket - CWPW	1	1571104
	802886		1	1571105
13	5260	Plate, On-Off	1	Both
14	22502	Strain Relief	1	Both
15	777836	Protector, Thermal -PW	1	Both
16	779165	Gun, QC-PW	1	Both
17	221222	Strainer, Chemical- PW	1	Both
18	803864	Nozzle, 4 Pack, #5.5 - PW	1	1571104
	803866	Nozzle, 4 Pack, #4.5 HWPG	1	1751105
19	779761	Hose/Cord Mount-PW	1	Both
20	803709	Lance,18.5"	1	Both
21	802781	Control Box - CWPW	1	Both
22	802782	Gasket, Control Box - CWPW	1	Both
23	802173	Billboard With Decal, CWPW	1	Both
24	800402	Tire, 10" Welded	2	Both
25	305200	Retainer, Wheel	2	Both
26	2215	Bumper	2	Both
27	35198	Grommet,7/16 ID-14GA-16A - PW	5	Both
28	792433	Grommet,1.25"HOLE X 1"OPENING	1	Both
29	82006	Screw, 10-32 X 1/2 SHCS Y/Z	2	Both
30	82007	SHCS, 10-32 X 3/4 YELLOW ZINC	1	Both
31	82008	Nut, 10-32 KEPS (Price per 100)	4	Both
32	82009	Bolt, 1/4-20 X 3/4 HHSF GR5Z	6	Both
33	82013	Nut, 1/4-20 SER.FLG Z	6	Both
34	87164	Bolt, 3/8x1 Shoulder 5/16-18	2	Both
35	82630	5/16 Flange Nyloc Nut	8	Both
36	82233	Bolt, Carriage GR5Z 5/16-18X2PW	4	Both
37	38578	Knob, T-Handle - PW	2	Both
38	82232	Tapper, Self 1/4X3/4 TYPAB - PW	2	Both
39	82621	Bolt, 5/16 X .75 HHFB	4	Both
40	5265	Nut, Wire	1	Both
41	777838	Plug, HEX 1/4"C. Sunk-PW	1	Both
42	35408	Nut, Wire Red - AC 459242	2	Both
43	305276	Insulated FEM SPADE TERMPW, GN	2	Both
44	777855	Switch, Toggle	1	Both
45	778139	Wire Lead, White, PW	1	Both
46	35383	Wire, 45924 Assembly (B2) -AC	1	Both
47	803071	Wire, Cord 10/3 AWG SJTW	1	1571104
	803072	Wire, Cord 8/3 AWG SJTW	1	1571105
48	778152	Contactor, DP 230V/30A	1	1571104
	802887		1	1571105
49	799485	Cord, GFCI, 240V,10AWG,36ft-PW	1	1571104
	803217	Cord, GFCI, 240V40A, 8AWG, 36" With Decal	1	1571105
50	803068	Switch, Flow 12GPM	1	Both

Parts List - Model #1571104 & 05

REF#	PART#	DESCRIPTION	QTY	MODEL#
51	803129	Strain Relief, 3/4" (.492-.709") - PW	2	1571104
	803097	Strain Relief, 1-1/4" NPT	2	1571105
52	803099	Strain Relief, 1" NPT, 10GA Cord-PW	1	1571104
	803097	Strain Relief, 1-1/4" NPT	1	1571105
53	87170	Bolt, 1/4-20 X 3/4" SHTS	4	Both
54	777495	Nut, Nylock M8-1.25 ZINC - GN	2	Both
55	802769	Decal, NS Branding Portable	1	Both
56	791308	Nozzle Quick Coupler	1	Both
57	777914	Hose Quick Coupler	1	Both
58	777915	Hose Quick Coupler Nipple	1	Both
59	800401	Billboard Decal	1	Both

Pump Assemblies

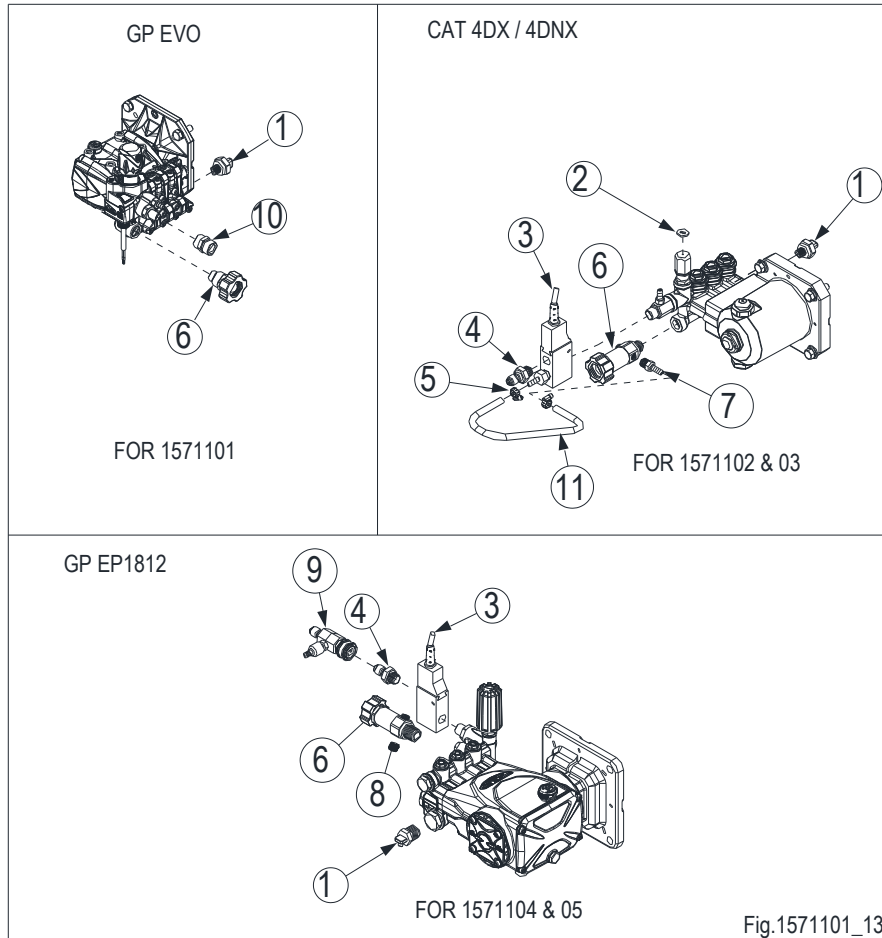
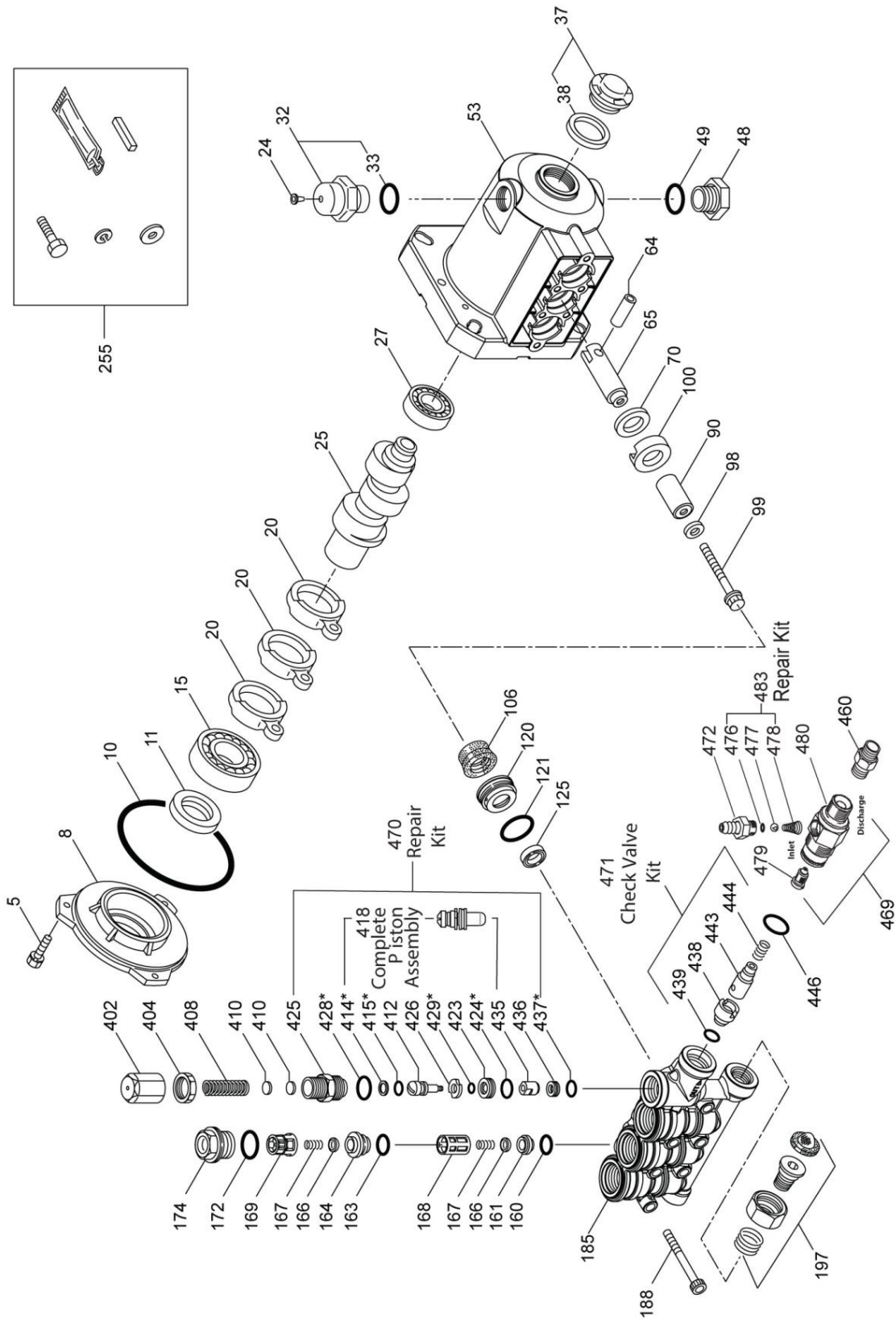

Fig.1571101_13

Ref#	Part#	Description	Qty	Model#
1	35918	Protector, Thermal	1	ALL
2	82047	Washer, M8 Rib	1	1571102
3	802097	Switch, Flow 12gpm W/ Pilot	1	1571102, 03
	803068	Switch, Flow 12gpm W/O Pilot	1	1571104, 05
4	777913	Nipple, Male O.C. 3/8-Pw	1	1571102, 03, 04, 05
5	777834	Clamp, 1/4" Hose	2	1571102, 03
6	803134	Filter, Inlet	1	1571101
	800985	Filter, Inlet, 3/8" Npt X 3/4" Fgh	1	1571102, 03
	800986	Filter, Inlet, 1/2" Npt X 3/4" Fgh	1	1571104, 05
7	777340	Barb, Hose Br 1/4 Mpt X 1/4(Pw)	1	1571102, 03
8	777838	Plug, Hex 1/4"C. Sunk-Pw	1	1571104, 05
9	779613	Injector, Quick Connect	1	1571104, 05
10	803135	Fitting, 3/8" Npt-F To M22-M - Pw	1	1571101
11	805557	Hose, 1/4" Braided Chemical – 36"	1	1571102, 03

Pump Exploded View – Cat 4DX



Pump Parts List – Cat 4DX

Ref#	P/N	DESCRIPTION	QTY
5	<i>Not Available</i>	Screw	3
8	CA547153	Bearing Cover	1
10	CA14041	O-Ring, Bearing Cover	1
11	CA55337	Oil Seal	1
15	CA14488	Inner Ball Bearing	1
20	CA547048	Connecting Rod	3
24	<i>Not Available</i>	Oil Plug Cap	1
25	<i>Not Available</i>	Crankshaft	1
27	CA15710	Ball Bearing	1
32	CA547961	Cap	1
33	CA14179	O-ring for Oil Filter Cap	1
37	CA92241	Gauge, Bubble Oil w/Gasket	1
38	CA44428	Gasket, Flat Flex Oil Gauge	1
48	CA44842	Drain Plug	1
49	CA14179	O-Ring for Drain Plug	1
53	<i>Not Available</i>	Crankcase	1
64	CA46229	Crosshead Pin	3
65	CA132190	Plunger Rod	3
70	CA47215	Oil Seal	3
90	CA542403	Plunger	3
98	CA46730	Washer	3
99	CA542405	Retainer, Plunger	3
100	CA46233	Retainer, Seal	3
106	CA48222	Seal	3
120	CA547357	Seal Case	3
121	CA13976	O-Ring for Seal Case	3
125	CA46240	Seal	3
160	CA13965	O-Ring, Inlet	3
161	CA545177	Seat, Inlet	3
163	CA19285	O-Ring	3
164	CA545178	Seat, Discharge	3
166	CA46764	Valve	6
167	CA46865	Spring	6
168	CA543988	Retainer, Spring, Inlet	3
169	CA49764	Retainer, Spring, Discharge	3
172	CA142807	O-Ring for Plug	3
174	CA547104	Plug, Valve w/O-ring	3
185	<i>Not Available</i>	Head, Manifold w/Unloader Body	1
188	<i>Not Available</i>	Screw	6

Ref#	P/N	DESCRIPTION	QTY
197	CA941516	Inlet Fitting Assembly	1
255	CA30516	Bolt Mount Assembly	1
401	CA32088	Handle Adjustable (Not Shown)	1
402	CA46570	Adjusting Cap	1
404	CA45070	Lock Nut	1
408	CA33394	Pressure Spring	1
410	CA549352	Spring Retainer	1
412	CA46251	Piston Stem	1
414	CA28338	Back Up Ring	1
415	CA22056	O-Ring, Piston Stem	1
418	<i>Not Available</i>	Piston Assy (Included in # 470)	1
423	CA46249	Retainer Valve	1
424	CA13966	O-Ring, Valve Retainer (Outer)	1
425	CA46248	Piston Retainer	1
426	CA46250	Washer	1
428	CA26133	O-Ring	1
429	CA17399	O-Ring, Valve Retainer	1
435	CA548193	Valve	1
436	CA46253	Seat	1
437	CA13963	O-Ring, Seat	1
438	CA46254	Seat, Check Valve	1
439	CA13963	O-Ring, Check Valve Seat	1
443	CA541060	Valve, Check	1
444	CA45924	Spring	1
446	CA26133	O-Ring	1
460	CA107681	Discharge Fitting	1
469	CA7231	Chemical Fixed Injector	1
470	CA76031	Unloader Repair Kit Includes: 418, 428, 436, 437	1
471	CA76146	Check Valve Kit Includes: 438, 439, 443, 444, 446	1
472	CA46630	Barb	1
476	<i>Not Available</i>	Barb O-Ring	1
477	<i>Not Available</i>	Ball	1
478	<i>Not Available</i>	Spring	1
479	<i>Not Available</i>	Orifice	1
480	<i>Not Available</i>	Body	1
483	CA76176	Repair Kit	1
Kit #1	CA33053	Seal Kit Includes: 98, 106, 121, 125	1
Kit #2	CA76978	Valve Kit Includes: 160, 161, 162, 163, 164, 166, 167, 168, 169, 172	1
*	CA76754	O-ring Kit Includes: 414, 415, 424, 428, 429, 437	1

Pump Exploded View – Cat 4DNX

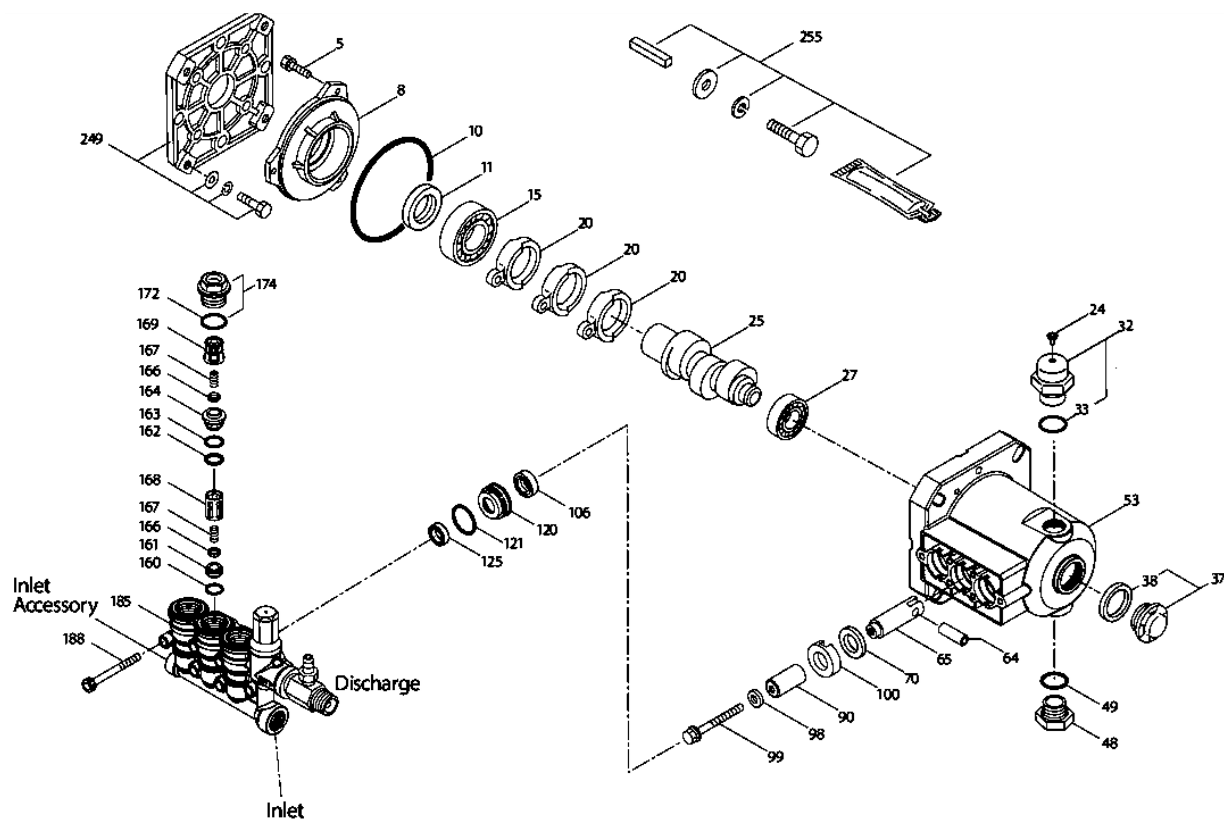

Ref#	P/N	DESCRIPTION	QTY
5	CA549360	Screw	3
8	CA547153	Bearing Cover	1
10	CA14041	O-Ring, Bearing Cover	1
11	CA55337	Oil Seal	1
15	CA14488	Inner Ball Bearing	1
20	CA547048	Connecting Rod	3
24	<i>Not Available</i>	Oil Plug Cap	1
25	CA49883	Crankshaft	1
27	CA15710	Ball Bearing	1
32	CA547961	Cap	1
33	CA14179	O-Ring For Oil Filter Cap	1
37	CA92241	Gauge, Bubble Oil W/Gasket	1
38	CA44428	Gasket, Flat Flex Oil Gauge	1
48	CA44842	Drain Plug	1
49	CA14179	O-Ring For Drain Plug	1
53	<i>Not Available</i>	Crankcase	1
64	CA46229	Crosshead Pin	3
65	CA542402	Plunger Rod	3
70	CA47215	Oil Seal	3
90	CA547091	Plunger	3
98	CA46730	Washer	3
99	CA542405	Retainer, Plunger	3

Ref#	P/N	DESCRIPTION	QTY
100	CA46233	Retainer, Seal	3
106	CA49816	Seal	3
120	<i>Not Available</i>	Seal Case	3
121	CA13976	O-Ring For Seal Case	3
125	CA49824	Seal	3
160	CA17428	O-Ring, Inlet	3
161	CA547077	Seat, Inlet	3
162	CA48361	Back-Up Ring	3
163	CA43358	O-Ring	3
164	CA547076	Seat, Discharge	3
166	CA547098	Valve	6
167	CA46865	Spring	6
168	CA543988	Retainer, Spring, Inlet	3
169	CA49764	Retainer, Spring, Discharge	3
172	CA142807	O-Ring For Plug	3
174	CA547104	Plug, Valve W/O-Ring	3
185	<i>Not Available</i>	Head, Manifold W/Unloader Body	1
188	CA549357	Screw	6
249	CA30520	Adapter Mount Assembly	1
255	CA30516	Bolt Mount Assembly	1
300	CA76975	Seal Kit Includes: 98, 106, 121, 125	1
310	CA76976	Valve Kit Includes: 160, 161, 162, 163, 164, 166, 167, 168, 169, 172	1

Pump Exploded View – Cat 4DNX

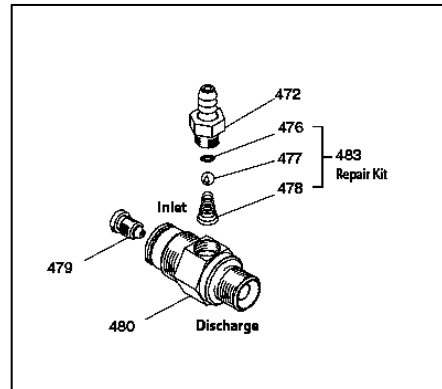
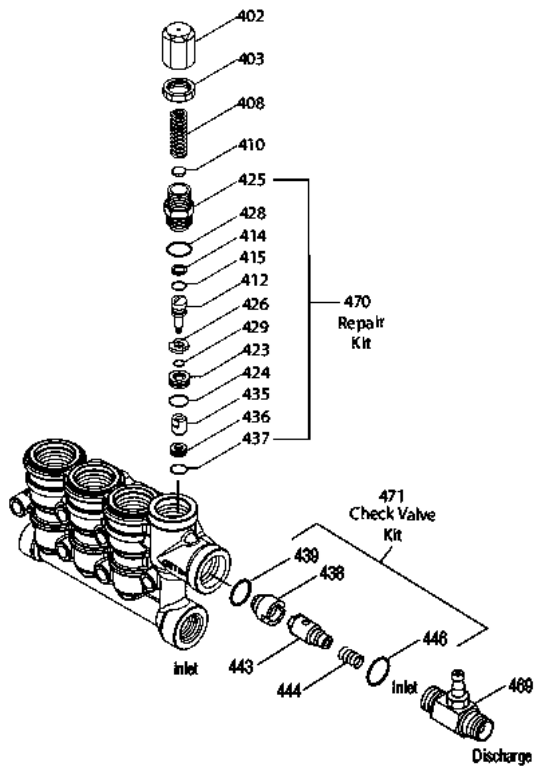

Ref#	P/N	DESCRIPTION	QTY
402	CA547798	Adjusting Cap	1
403	CA45070	Lock Nut	1
408	CA32094	Pressure Spring	1
410	CA549352	Spring Retainer	1
412	CA45694	Piston Stem	1
414	CA20184	Back Up Ring	1
415	CA14190	O-Ring, Piston Stem	1
423	CA46249	Retainer Valve	1
424	CA13966	O-Ring, Valve Retainer (Outer)	1
425	CA547799	Piston Retainer	1
426	CA46250	Washer	1
428	CA26133	O-Ring, Valve Retainer	1
429	CA17399	O-Ring, Piston Retainer (Inner)	1
435	CA547800	Valve	1
436	CA49664	Seat	1
437	CA13963	O-Ring, Seat	1

Ref#	P/N	DESCRIPTION	QTY
438	CA46254	Seat, Check Valve	1
439	CA13963	O-Ring, Check Valve Seat	1
443	CA49765	Valve, Check	1
444	CA45924	Spring	1
446	CA26133	O-Ring, Body	1
468	CA31767	O-Ring Kit Includes: 414, 415, 424, 428, 429, 437, 439, 446	1
469	CA7332	Chemical Fixed Injector	1
470	CA76179	Unloader Repair Kit Includes: 412, 414, 415, 423, 424, 425, 426, 428, 429, 435, 436, 437	1
471	CA76146	Check Valve Kit Includes: 438, 439, 443, 444, 446	1
472	Not Available	Barb	1
476	Not Available	O-Ring, Barb -70d	1
477	Not Available	Ball	1
478	Not Available	Spring	1
479	Not Available	Orifice	1
480	Not Available	Body	1
483	CA76176	Kit, Repair (Includes: 476, 477, 478)	1

Pump Exploded View – GP PUMP

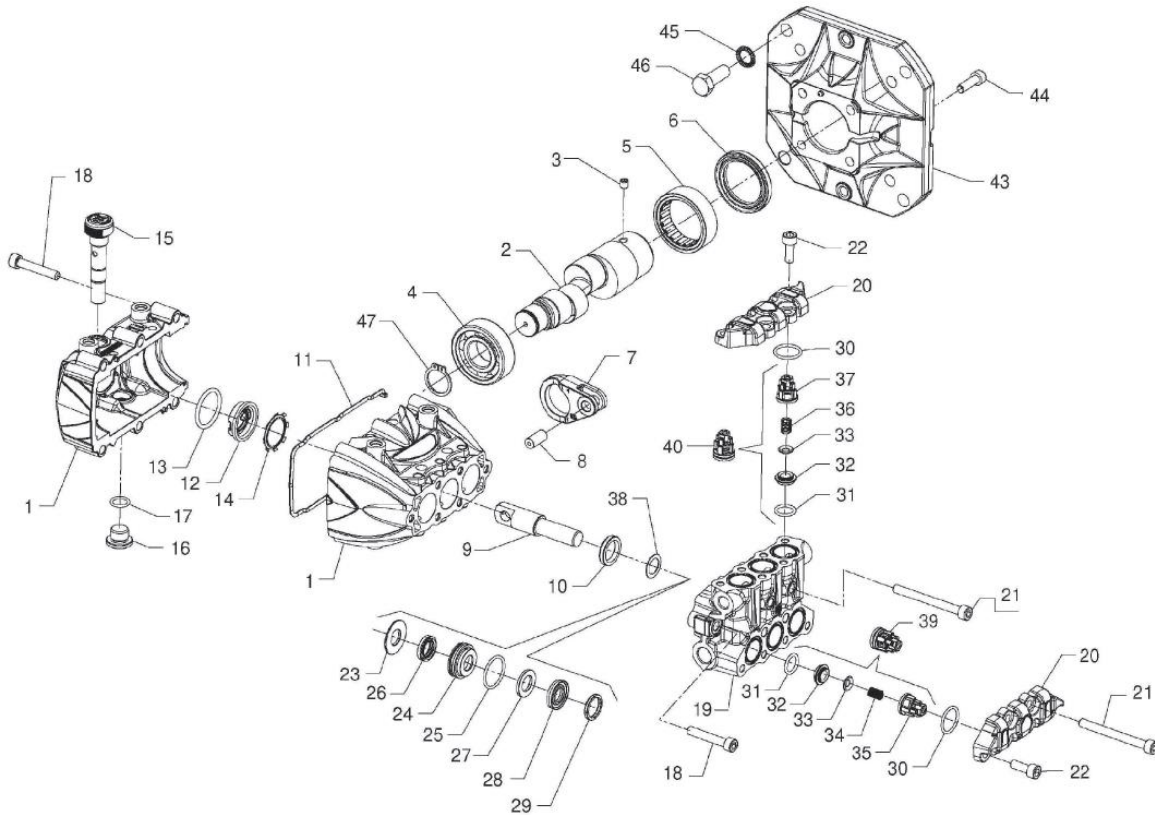

Ref#	P/N	DESCRIPTION	QTY
1	Not Available	Crankcase	4
2	Not Available	Crankshaft (EM12048EUIITS)	1
3	GP 99179000	Screw, M6x06	1
4	GP91822100	Ball Bearing	1
5	GP91846000	Roller Bushing	1
6	GP90166000	Radial Ring, Ø35.0x47.0x6.0	1
7	GP83030022	Connecting Rod	3
8	GP97730500	Pin, Ø8.0x17.0	3
9	GP83040101	Plunger Assy., Ø12	3
10	GP90158000	Radial Ring, Ø6.0x22.0x4.0	3
11	GP83210747	Gasket, Crankcase	1
12	GP53210851	Oil Level Sight Glass	1
13	GP90385900	O-ring, Ø25.07x2.62	1
14	GP90067100	Stop Ring	1
15	GP98204900	Oil Dipstick	1
16	GP98204150	Screw, G 1/4"x9	1
17	GP701013	O-ring, Ø 10.82x1.78	1
18	GP99192600	Screw, M6x35	8
19	Not Available	Manifold, Ø12	1
20	GP83210013	Valve Cover	2
21	GP99199000	Screw, M6x60	4
22	GP99185400	Screw, M6x16	10
23	GP83210370	Seal Ring, Ø 12	3
24	GP83210270	Gasket Support, Ø 12	3

Ref#	P/N	DESCRIPTION	QTY
25	GP90360000	O-ring, Ø 21.95x1.78	3
26	GP90258950	Seal Ring, Ø 12.0x18.5x4.5	3
27	GP90507080	Anti-extrusion Ring	3
28	GP90258900	Seal Ring, Ø 2.0x21.0x4.2	3
29	GP83100051	Head Ring, Ø 12	3
30	GP90359500	O-ring, Ø 17.17x1.78	6
31	GP90367400	O-ring, Ø 12.00x2.00	6
32	GP36211366	Inlet Valve Seat	6
33	GP36211276	Spherical Inlet Valve	3
34	GP94732600	Spring, Inlet, 6.0x12.0	3
35	GP36211951	Valve Guide, Inlet	3
36	GP94733300	Spring, Outlet, 6.7x10.8	3
37	GP36211151	Outlet Valve Guide	3
38	GP83210851	Ring	3
39	GP36722401	Inlet Valve Assembly	3
40	GP36719301	Outlet Valve Assembly	3
41	GP83210113	Valve Cover, G1/8 opt.	1
42	GP98196800	Plug, G1/8 opt.	1
43	GP10098422	Flange, Electric, 56C	1
44	GP99188400	Screw M6x20	4
45	GP96710400	Washer Ø 10.5x16.0x1.0	4
46	GP99334500	Screw, 3/8"-16x1"	4
47	GP90060500	Anti-extrusion Ring	1

Pump Exploded View – GP PUMP

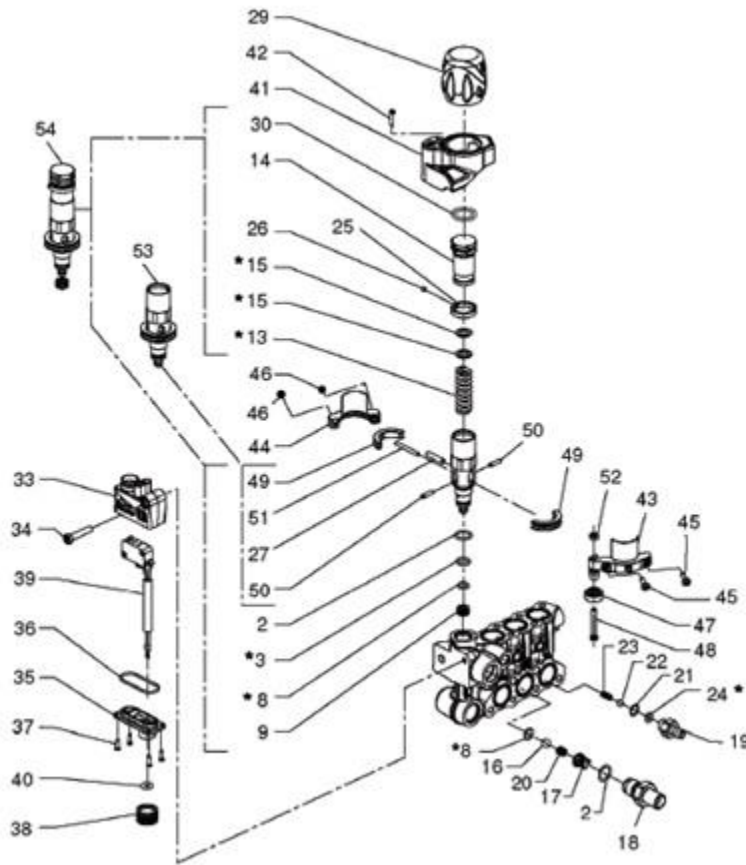

Ref#	P/N	DESCRIPTION	QTY
2	GP90358700	O-ring Ø 1.11x1.78	2
3	GP90358100	O-ring Ø 8.73x1.78	1
8	GP90357600	O-ring, Ø 6.75x1.78	2
9	GP36357100	Valve Seat	1
13	GP94739650	Spring, Ø 11.1x39.5	1
14	GP36356970	Pressure Regulator	1
15	GP36357051	Sliding Washer	2
16	GP97480200	Ball, 9/32"	1
17	GP36356551	Valve Guide	1
18	GP36356870	Nipple, Ø 1.8 G1/4"-M	1
19	GP36357770	Injector	1
20	GP94733250	Spring, 6.2x8.0	1
21	GP90365000	O-ring, Ø 8.00x1.00	1
22	GP97478200	Ball, 7/32"	1
23	GP94730770	Spring, 4.2x13.5	1
24	GP90357300	O-ring, Ø 5.28x1.78	1
25	GP36357670	Maximum Pressure Ring	1
26	GP99070000	Screw, M3x03	1
27	GP97613800	Cylindrical Pin, 4.0m6x20.0	1
28	GP36356770	Nipple, Ø 6.0 G1/4"-M	1
29	GP36356151	Adjustment Knob 1 30	1
30	GP90383700	O-ring, Ø 15.54x2.62	1
31	GP96710000	Washer, Ø 10.0x14.0x1.5	1

Ref#	P/N	DESCRIPTION	QTY
32	GP98196800	Plug, G 1/8"x8	1
33	GP36355951	Box	1
34	GP99159400	Screw, M5x25 7984	1
35	GP36355451	Box Cover	1
36	GP90360800	O-ring, Ø 28.30x1.78	1
37	GP99034400	O-ring, Ø 2.2x9.5 7049	4
38	GP92974100	M14x1.5	1
39	GP10745901	Wiring Switch	1
40	GP90381400	O-ring, Ø 5.23x2.62	1
41	GP36355551	Cover	1
42	GP99072900	Screw, 3x14 9707	1
43	GP36356351	Command Jaw	1
44	GP36356251	Clamping Jaw	1
45	GP99072930	Screw, M3x14	2
46	GP92193000	Nut, Ø M3x2.4	2
47	GP36358847	Bellows	1
48	GP36357465	Regulating Screw	1
49	GP36356651	Semi-disc	2
50	GP97613500	Cylindrical Pin, 3.0m6x12.0	2
51	GP97613700	Cylindrical Pin, 3.0m6x28.0	1
52	GP92192400	Nut, M4x3.2 5588	1
53	GP36607701	Shutter Guide	1
54	GP36607601	Valve Group	1

Pump Exploded View – GP PUMP

REPAIR KITS:

KIT NO.	GPK309	GPK400	GPK401	GPK402
KIT DESCRIPTION	INLET/OUTLET VALVE ASSEMBLY	GASKET, CRANKCASE	PLUNGER SEAL	PLUNGER SEAL WITH GASKET SUPPORT
ITEM NO'S INCLUDED IN KIT	39, 40	10	25, 26, 27, 28, 29	23, 24, 25, 26, 27, 28, 29
NUMBER OF PIECES	39-Qty 3, 40-Qty 3	3	3	1

Pump Exploded View – GP EP1812 PUMP

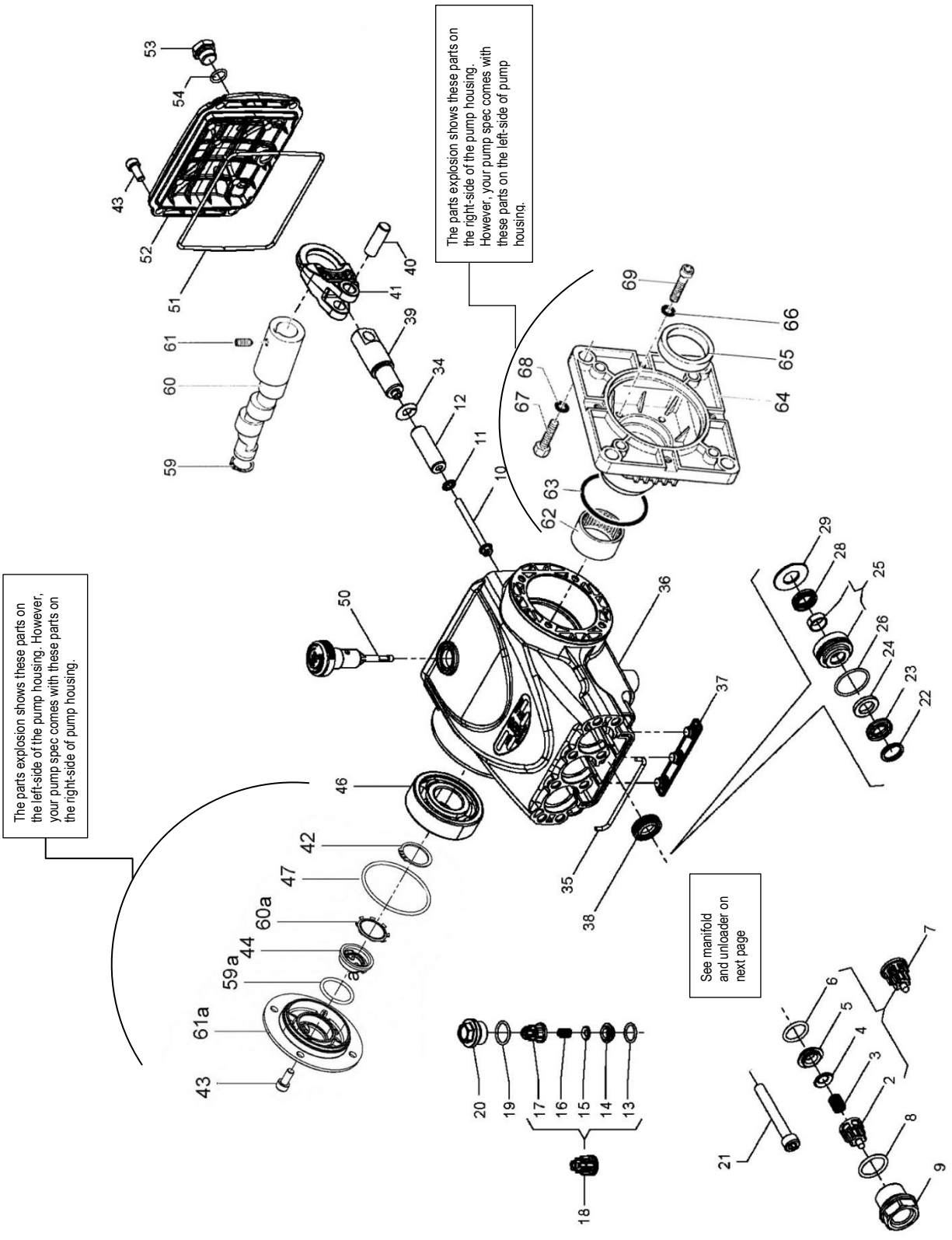

Pump Parts List – GP EP1812 PUMP

Ref#	P/N	DESCRIPTION	QTY
2	GP36202551	Valve Cage	3
3	GP94737600	Spring, Ø 9.4x14.8	3
4	GP36711501	Valve	3
5	GP36200366	Valve Seat	3
6	GP701115	O-Ring, Ø17.13x2.62	3
7	GP36711501	Valve Assembly	3
8	GP701002	O-Ring, Ø20.24x2.62	3
9	GP98222600	Valve Cap, M24x1.5x16.7	3
10	GP99169000	Plunger Bolt, M5x55	3
11	GP96690500	Washer, Ø 5x11.5x0.4	3
12	GP58040209	Plunger, Ø 18x42	3
13	GP701014	O-Ring, Ø 12.42x1.78	3
14	GP36211366	Outlet Valve Seat	3
15	GP36211276	Outlet Valve Poppet	3
16	GP94733300	Spring, Ø 6.2x10.4	3
17	GP36211151	Outlet Valve Cage Guide	3
18	GP36719301	Complete Outlet Valve	3
19	GP701016	O-Ring, Ø 15.6x1.78	3
20	GP98213700	Outlet Valve Cap, M18x1.5x10	3
21	GP99317500	Screw, M8x60	8
22	Not Available	Head Ring, Ø 18	3
23	Not Available	Packing, Ø 18, Hp	3
24	Not Available	Anti-Ext. Ring, Ø 18	3
25	GP58605801	Intermed. Ring, Ø 18	3
26	Not Available	O-Ring, 26.7x1.78	3
28	Not Available	Seal, Ø 18 Lp	3
29	GP58210870	Support Ring, Ø 18	3

Ref#	P/N	DESCRIPTION	QTY
34	GP96698000	Washer, Ø 7.5x15x0.5	3
35	GP58210582	Gasket, Ø 3x94	1
36	Not Available	Crankcase	1
37	GP58210451	Drip Cover	1
38	GP90156550	Oil Seal, Ø 15x24x5.7	3
39	GP58050066	Piston Guide	3
40	GP97734000	Piston Pin, Ø 10x29.5	3
41	GP58030022	Connecting Rod	3
44	GP44211801	Sight Glass	1
47	GP90409700	O-Ring, Ø 55.56x3.53	1
50	GP98210500	Oil Dipstick	1
51	GP90392550	O-Ring, Ø 113.97x2.62	1
52	GP58160022	Rear Cover	1
53	GP98204100	Plug, 1/4"X9	1
54	GP701013	O-Ring, Ø 10.82x1.78	1
59	GP90063500	Circlip	1
60	Not Available	Crankshaft, 12 Mm	1
61	GP99179000	Set Screw, M6x6	1
62	GP91856800	Needle Bearing	1
63	GP90409700	O-Ring, Ø 55.56x3.56	1
64	GP10050422	Electric Flange	1
65	GP90168700	Oil Seal	1
66	GP203510	Washer, Ø 6.4x10x0.7	4
67	GP99460000	Screw, Hex, 1/2"X1-1/4"	4
68	GP96719500	Washer, Ø 13x18x1.1	4
69	GP99191200	Screw, M6x30	4

REPAIR KITS:

KIT NO.	GPK269	GPK270	GPK271	Ø 18	
				GPK274	Not Available
ITEM NO'S INCLUDED IN KIT	7 (2, 3, 4, 5, 6), 18 (13, 14, 15, 16, 17)	8, 9, 19, 20	38	22, 23, 24, 26, 28	22, 23, 24, 25, 26, 28, 29
NUMBER OF ASSY'S IN KIT	6	6	3	3	1
NO. OF CYLINDERS KIT SERVICES	3	3	3	3	1

Pump Parts List – GP EP1812 PUMP

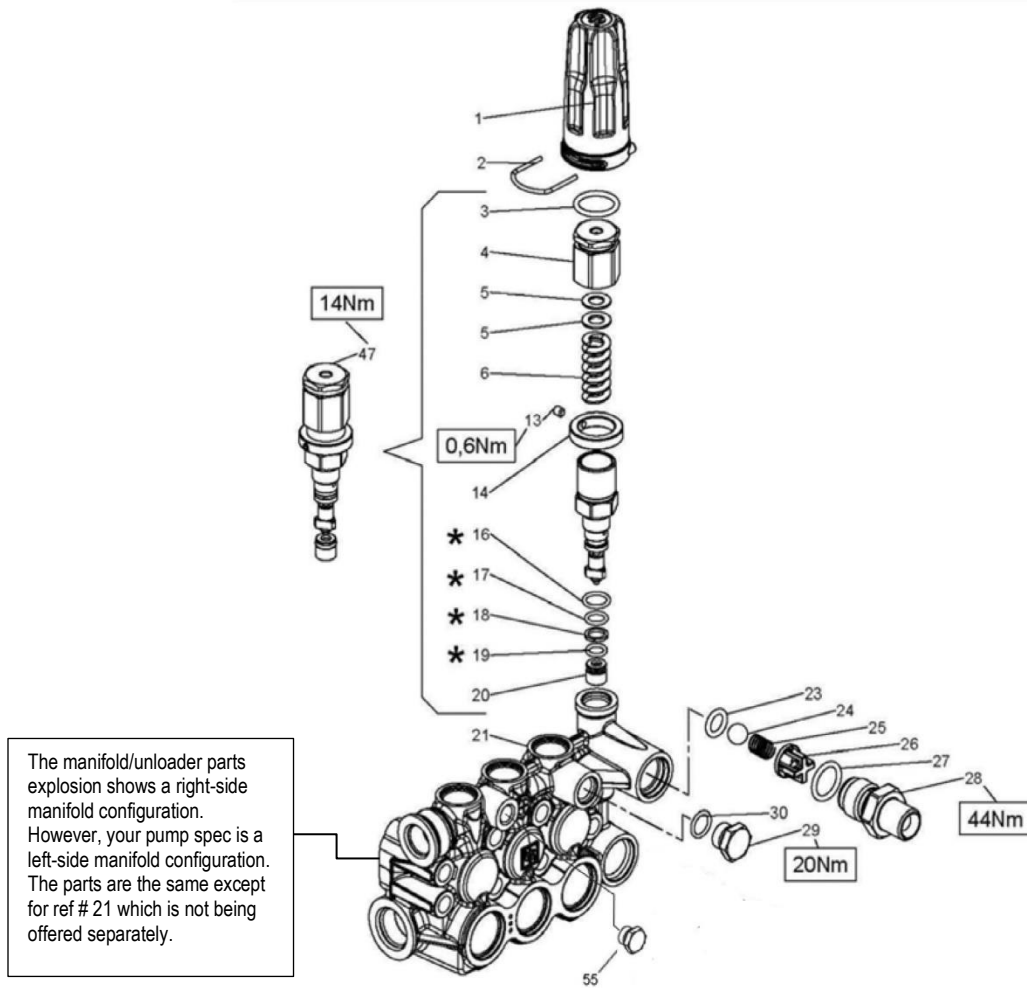

Ref#	P/N	DESCRIPTION	QTY	Ref#	P/N	DESCRIPTION	QTY
1	GP36350651	Adjustment knob	1	20	Not Available	Seat	1
2	GP10084666	Fork for adjustment knob	1	21	Not Available	Manifold, left side unloader	1
3	Not Available	O-ring, Ø18.72x2.62	1	23	GP90382300	O-ring, Ø9.92x2.62	1
4	Not Available	Pressure adjusting nut	1	24	GP97483800	Ball, Ø13/32"	1
5	Not Available	Washer	2	25	GP94735500	Spring, Ø8.2x12	1
6	Not Available	Spring, Ø11.3x34.5	1	26	GP36310451	Valve guide	1
13	Not Available	Screw, M4X5	1	27	GP90383900	O-ring, Ø15.88x2.62	1
14	Not Available	Pressure ring	1	28	GP36348770	Nipple, 3/8" NPT-M	1
16	GP90358700	O-ring, Ø11.11x1.78	1	29	GP98204100	Plug, 1/4"x9 (U)	1
17	GP90358100	O-ring, Ø8.73x1.78	1	30	GP90358500	O-ring, Ø10.82x1.78 (U)	1
18	Not Available	Anti-extrusion ring	1	47	GP36605401	Valve Assembly	1
19	GP90357800	O-ring, Ø7.66x1.78	1	55	GP98196600	Plug, 1/8"x8	1

Wiring Diagram

Model# 1571101

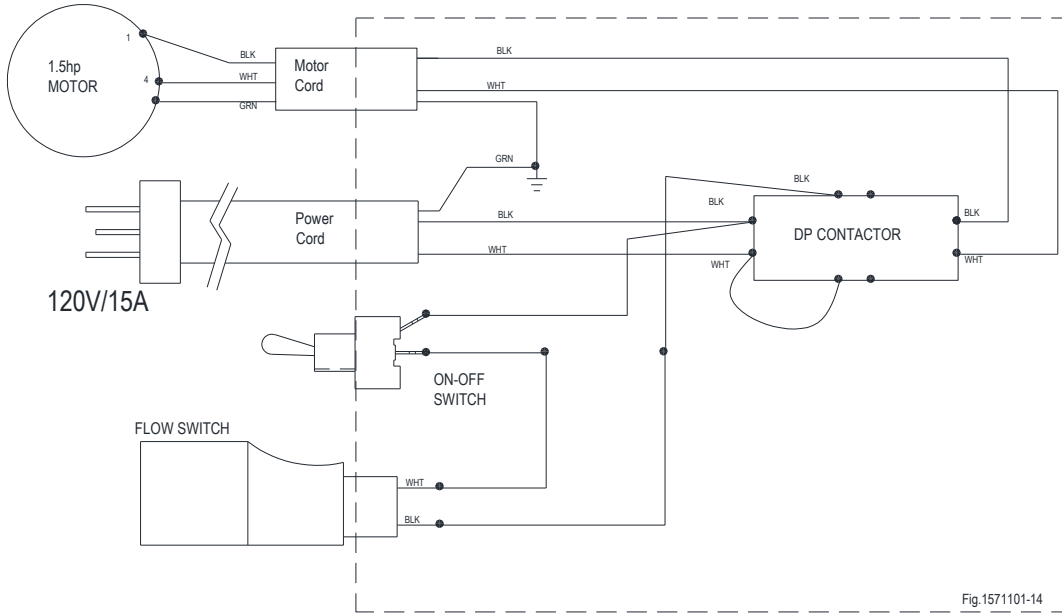

Model# 1571102

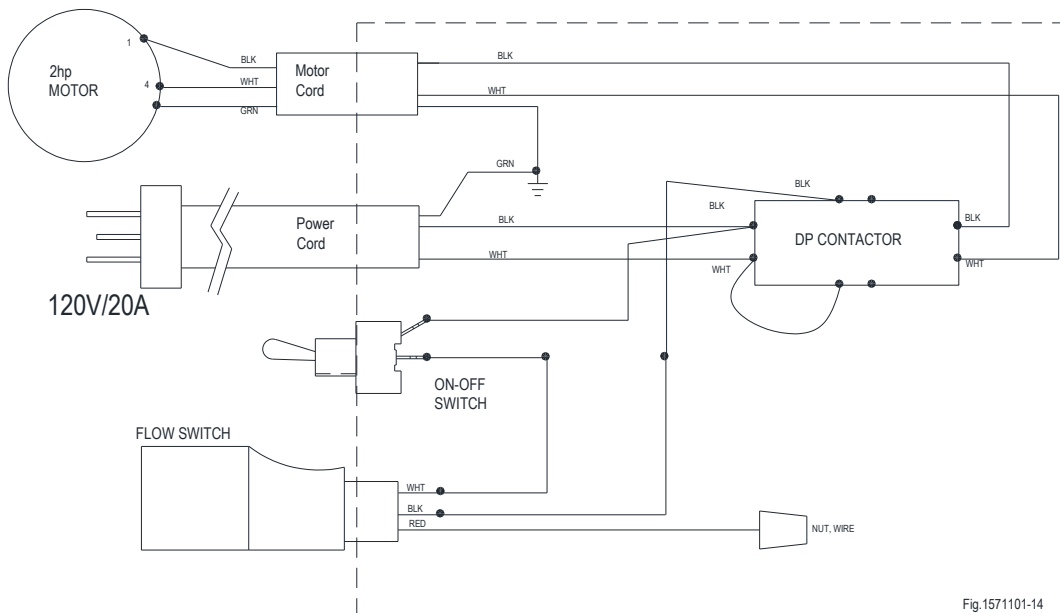

Wiring Diagram

Model# 1571103 & 1571104

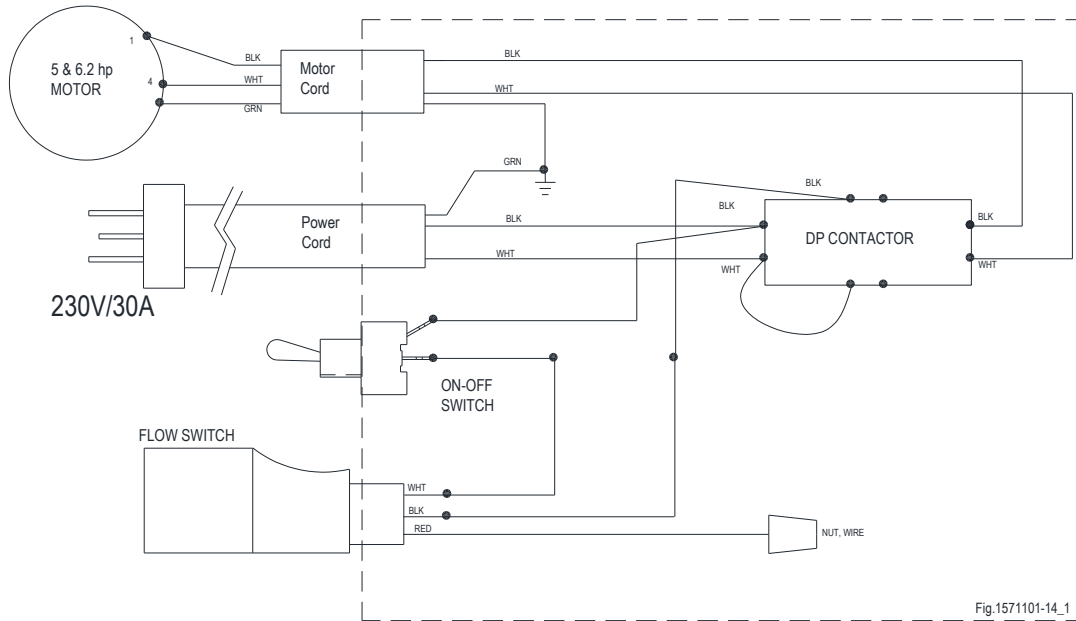

Model# 1571105

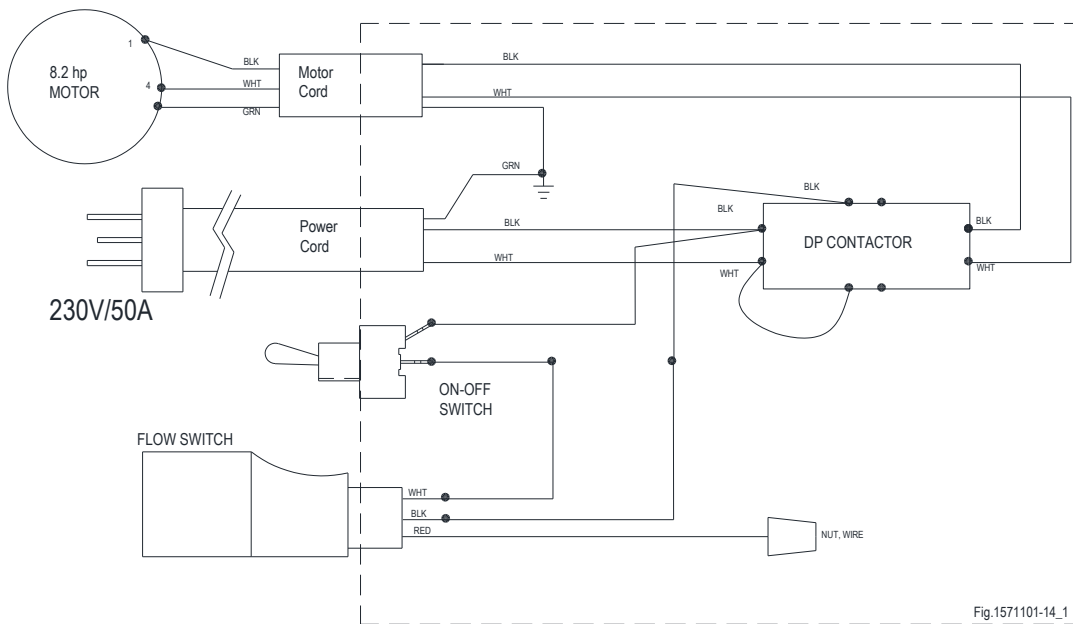

Limited Warranty

Dear Valued Customer:

The NorthStar Product you just purchased is built with the finest material and craftsmanship. Use this product properly and enjoy the benefits from its high performance. By purchasing a NorthStar product, you show a desire for quality and durability. Like all mechanical equipment this unit requires a due amount of care. Treat this unit like the high-quality piece of machinery it is. Neglect and improper handling may impair its performance. Please thoroughly read the instructions and understand the operation before using your product. Always contact NorthStar Product Support at 1-800-270-0810 prior to having any service or warranty work performed, as some services performed by parties other than NorthStar approved service centers may void this warranty. This warranty is in lieu of any other warranty expressed or implied and NorthStar assumes no other responsibility or liability outside that expressed within this warranty.

Limited Warranty

Limited Warranty

NorthStar shall warranty any piece of equipment manufactured, or parts of equipment manufactured, to be free from defects in material or workmanship for a period of:

Item Number	Item Name	Commercial/Consumer Warranty	Details
ALL	NorthStar	10 years from date of purchase	NorthStar shall warrant structural components from failure for a period of 10 years from the date of purchase by user. Structural parts include but are not limited to, cart, handle, billboard and bumper tube
ALL	Pump	5 years from date of purchase, Lifetime on pump manifold	NorthStar shall warrant the pressure washer pump to be free of defects in material and workmanship for a period of 5 years. NorthStar makes no warranty on standard wear items such as, but not limited to, seals, valves, seats, O-rings and pistons.
ALL	Motor	2 years from date of purchase	The motor warranty is covered under the terms and conditions as outlined by the motor manufactures warranty and is the sole responsibility of the motor manufacture. Normal motor maintenance such as system cleaning and obstruction due to build up is not covered by this NorthStar warranty.
ALL	Normal Wear Items	90 days from date of purchase	In addition to the normal warranty, NorthStar shall warrant any normal wear item from defects in material or workmanship for a period of 90 days from the date of purchase by user. Normal wear items include, but are not limited to, nozzles, quick connect fittings, valves, high- pressure hoses, O-rings, filter elements, Gun, Lance, Tires, and unloader valves

“Consumer use” means personal residential household use by a consumer. “Commercial use” means all other uses, including use for commercial, income producing or rental purposes or when purchased by a business.

This warranty applies to the original purchaser of the equipment (verification of purchase, in the form of a receipt, is the responsibility of the buyer), is non-transferable, and covers parts and labor. Parts will be replaced or repaired at no charge, except when the equipment has failed due to lack of proper maintenance. If a part is no longer available, the part may be replaced with a similar part of equal function. Any misuse, abuse, alteration or improper installation or operations will void warranty. Determining whether a part is to be replaced or repaired is the sole decision of NorthStar. NorthStar will not provide for replacement of complete products due to defective parts. Any costs incurred due to replacement or repair of items outside of a NorthStar approved facility is the responsibility of the buyer and not covered under warranty. Transportation costs to and from service center is the responsibility of the customer.

This warranty specifically excludes the following; failure of parts due to damage caused by accident, fire, flood, windstorm, acts of God, applications not approved by NorthStar in writing, corrosion caused by chemicals, use of replacement parts which do not conform to manufacturer’s specifications, damage related to rodent and/or insect infestation and damage caused by vandalism. Additional exclusions: loss of running time, inconvenience, loss of income, or loss of use, including any implied warranty of merchantability of fitness for a specific use. Also, Outdoor Power Equipment needs periodic parts and service to perform well, and this warranty does not cover instances when normal use has exhausted the life of a component or the motor.

This warranty does not cover any personal injury or damage to surrounding property caused by failure of any part. Repair or replacement of parts does not extend the warranty period.

Limited Warranty Continued

The motor warranty is covered under the terms and conditions as outlined by the moto manufactures warranty contained herein and is the sole responsibility of the motor manufacture. Normal motor maintenance such as system cleaning and obstruction due to build up is not covered by this NorthStar warranty.

Please fill in the following information and have it on hand when you call in on a warranty claim.

Customer Number: _____

Date of Purchase: _____

NorthStar Serial Number: _____

Item Number: _____

This page is intentionally left blank.

⚠ WARNING: This product can expose you to soots, tars, and mineral oils (untreated and mildly treated oils and used pump oils), which are known to the state of California to cause cancer.

For more information go to www.P65Warnings.ca.gov.



Assembled by
Northern Tool & Equipment Company, Inc.
Burnsville, MN 55306
NorthernTool.com