



Porto-Power Blackhawk Automotive is a licensed trademark

5 Ton Flat Body Ram Kit

Operating Instructions & Parts Manual

B65139

SFA Companies
10939 N. Pomona Ave. Kansas City, MO 64153
816-891-6390
sales@blackhawk-automotive.com

- Before using this product, read this manual and follow all its Safety Rules and Operating Instructions

Made in Taiwan
B65139-M0 rev 02/05

SAVE THESE INSTRUCTIONS

For your safety, read and understand the information contained within. The owner and operator shall have an understanding of this product and safe operating procedures before attempting to use this product. Make certain that the operator thoroughly understands the inherent dangers associated with the use and misuse of the product. If any doubt exists as to the safe and proper use of this product as outlined in this factory authorized manual, remove from service immediately. **Inspect before each use.** Do not use if leaking, broken, bent, cracked or otherwise damaged parts are noted. If the ram has been or suspected to have been subjected to a shock load, (a load dropped suddenly, unexpectedly upon it), discontinue use until checked out by an authorized factory service center. Owners and operators of this equipment shall be aware that the use and subsequent repair of this equipment may require special training and knowledge. It is recommended that an annual inspection be done by qualified personnel and that any missing or damaged parts, decals, warning / safety labels or signs be replaced with factory authorized replacement parts only. Any ram that appears to be damaged in any way, is worn or operates abnormally shall be removed from service immediately until such time as repairs can be made.

PRODUCT DESCRIPTION

Porto-Power Blackhawk Automotive Flat Body Ram is engineered to meet or exceed ANSI B30.1 Standards for performance and safety. This ram is designed for rated capacity lifting, lowering, pushing, spreading and pressing jobs. Porto-Power Blackhawk Automotive Flat Body Ram Kit consists of a flat body ram, four magnetic adapters, operator's manual and a blow molded case. These four pieces of different height adapters ranges from 0.25 inch to 1.25 inch are provided to extend the working height. A wide variety of applications exist for this category of product. Special skill, knowledge and training may be required for a specific task and the product may not be suitable for all the jobs described above. Unsuitable applications would include applications that call for a device to move, level or support persons, animals, hazardous materials, mobile homes / dwellings in general, mirrors and/or plate glass, and/or to connect/secure hatches, components, etc. between bulkheads. The user must make the decision regarding suitability of the product for any given task and therefore accept responsibility for that decision.

Note: Always check connections before using. Alteration of these products is strictly prohibited.

SPECIFICATIONS

Model Number	Ram Capacity (tons)	Stroke (in)	Ram Effective Area (in ²)	Oil Capacity (in ³)	Collapsed Height (in)	Extended Height (in)	Weight (lbs)	Operating Pressure (psi)
B65139	5	0.24	1.1	0.26	1.26	1.5	5.5	9100

Magnetic adapter's height

Adapter I: 0.25 in

Adapter II: 0.50 in

Adapter III: 1.00 in

Adapter IV: 1.25 in

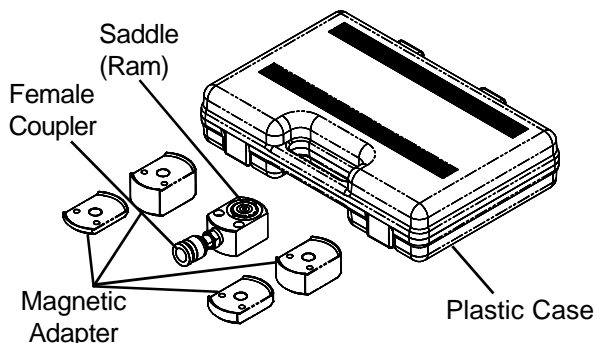
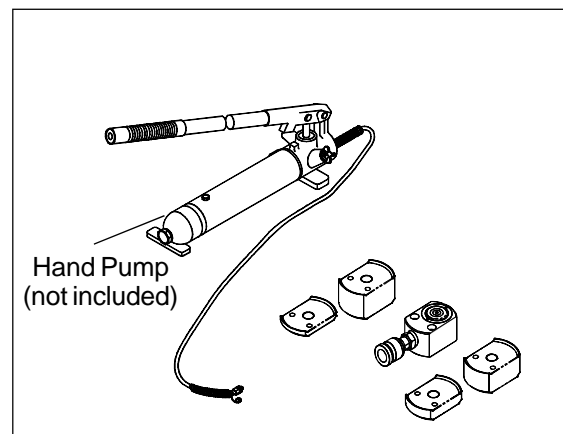

Figure 1 - Model B65139 Components

TYPICAL INSTALLATION



SAFETY INSTRUCTIONS

BEFORE USE

1. Before using this product, read the owner's manual completely and familiarize yourself thoroughly with the product, its components and recognize the hazards associated with its use.
2. Verify that the product and the application are compatible. Inspect before each use. Do not use if bent, broken, leaking or damaged components are noted.
3. Carefully remove the dust cover and plug from hose coupler and ram coupler.
4. Connect hose coupler to ram coupler, ensure that there are no fluid leaks.
5. Check for leaks in system and have repaired by qualified personnel as needed. Before repairs are made, depressurize ram.
6. Replace worn or damaged parts and assemblies with Porto-Power Blackhawk Automotive Authorized Replacement Parts only (See Replacement Parts Section). Lubricate as instructed in Maintenance Section.
7. Use adequate eye protection when operating or near this equipment.
8. Ensure method of confirming load is accurate and working properly. Have gauge or load cell accuracy verified by qualified personnel on a yearly basis.
9. Ram should be stored where protected from the elements, abrasive dust, and damage. This ram should be stored in the vertical position.



! DANGER !

- If oil leakage is detected, discontinue use of the ram immediately and contact your nearest Porto-Power Blackhawk Hydraulics Authorized Service Center. The ram could develop excessive pressure and cause the ram, hose or coupler to burst, which could cause serious injury or death.
- When loading a ram, always insure that coupler, port, and adapter threads have not been damaged. Failure to do so could cause serious injury or death.
- Avoid off-center loads. Loading off center may damage the ram and cause loss of load, which may cause serious injury or death.
- Control the load at all times. Do not drop the load. Threads may shear and cause loss of the load, which may cause serious injury or death.

! WARNING

- **All WARNING** statements must be carefully observed to help prevent personal injury. Do not exceed rated ram capacity. Monitor pressure and load at all times. Always verify load with calibrated load cell and indicator, known good pressure gauge or equivalent devices. Wear protective clothing and safety goggles to reduce the risk of injection. Wear appropriate shoes. Do not wear sandals when operating this equipment. Do not wear jewelry when operating this equipment.

Hydraulic Hoses and Fluid Transmission Lines

- Avoid short runs of straight line tubing. Straight line runs do not provide for expansion and contraction due to pressure and/or temperature changes.
- Reduce stress in tube lines. Long tubing runs should be supported by brackets or clips. Before operating the pump, all hose connections must be tightened with the proper tools. Do not overtighten. Connections should only be tightened securely and leak-free. Overtightening can cause premature thread failure or high pressure fittings to burst.
- Should a hydraulic hose ever rupture, burst or need to be disconnected, immediately shut off the pump and release all pressure. Never attempt to grasp a leaking pressurized hose with your hands. The force of escaping hydraulic fluid can inflict injury.
- Do not subject the hose to potential hazard such as fire, sharp objects, extreme heat or cold, or heavy impact.

WARNING

- Do not allow the hose to kink, twist, curl, crush, cut or bend so tightly that the fluid flow within the hose is blocked or reduced. Periodically inspect the hose for wear, because any of these conditions can damage the hose and possibly result in personal injury.
- Do not pull, position or move setup by the hose. Doing so can damage the hose and possibly cause personal injury.
- Hose material and coupler seals must be compatible with hydraulic fluid used. Hoses also must not come in contact with corrosive materials such as battery acid, creosote-impregnated objects and wet paint. Hose deterioration due to corrosive material can result in personal injury. Never paint a coupler or hose.
- The user must be a qualified operator familiar with the correct operation, maintenance, and use of rams. Lack of knowledge in any of these areas can lead to personal injury.
- Read and understand all safety and warning decals and instructions.
- Use only approved accessories and approved hydraulic fluid. Hoses, seals and all components used in a system must be compatible with the hydraulic fluid used.
- Do not exceed the rated capacities of the rams. Excess pressure can result in personal injury.
- Inspect each ram and coupler before each use to prevent unsafe conditions from developing.
- Do not use rams if they are damaged, altered or in poor condition.
- Do not use ram with bent or damaged coupler.
- Under certain conditions, the use of an extension with a hydraulic ram may not be advisable and could present a dangerous condition.
- Avoid pinch points or crush points that can be created by the load or parts of ram.
- To help prevent material fatigue if the ram is to be used in a continuous application, the load should not exceed 85% of the rated capacity.
- Ram must be on a stable base which is able to support the load while pushing or lifting.
- Ensure ram is fully engaged into/onto adapters, extension accessories.

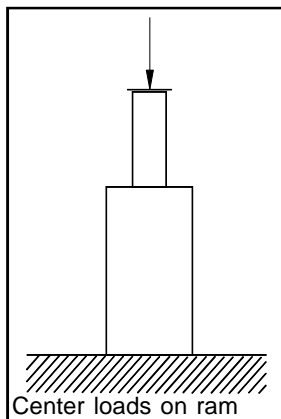

WARNING

- To help prevent personal injury, use shims, friction material or constraints to prevent slippage of the base or load.
- Do not off-center loads on a ram. The load can tip or the ram can "kick out" and cause personal injury.
- If this component is used to lift or lower loads, be certain that the load is under operator control at all times and that others are clear of the load. Do not drop the load.
- As the load is lifted, use blocking and cribbing to guard against a falling load.
- Never allow personnel to work on, under or around a load before it is properly supported by appropriate mechanical means. Never rely on hydraulic pressure alone to support load.
- All personnel must be clear before lowering.
- Never try to disassemble a hydraulic ram. Refer repairs to qualified, authorized personnel.

IMPORTANT

- Keep ram clean at all times.
- When the ram is not in use, keep the piston(s) fully retracted.
- Use an approved, high-grade pipe thread sealant to seal all hydraulic connections. Teflon tape can be used if only one layer of tape is used and it is applied carefully (two threads back) to prevent the tape from being introduced into hydraulic system. A piece of tape could travel through the system and obstruct the flow of fluid and adversely affect function.
- Never attach ANY component not authorized by manufacturer.
- Never use other than factory provided and/or authorized fasteners.

KNOW YOUR SYSTEM

Your ram, hose(s), couplings and pump all must be rated for the same maximum operating pressure, correctly connected and compatible with the hydraulic fluid used. An improperly matched system can cause the system to fail and possibly cause serious injury. If you are in doubt, consult your nearest Porto-Power Blackhawk Automotive Dealer.

SET UP

Remove thread protectors (dust covers) from hydraulic connections/ports. Clean the areas around the fluid ports of the pump and ram. Inspect all threads and fittings for signs of wear or damage, and replace as needed. Clean all threads and fittings. Connect all hose assemblies to the pump and ram. Use an approved, high-grade pipe sealant to seal all hydraulic connections. Tighten securely but do not overtighten.

MAINTENANCE

Due to superior materials and manufacturing processes, there is little maintenance required of this product. This fact does not preclude operator's responsibility to inspect each ram thoroughly before each use.

1. Always use clean, approved hydraulic fluid and change as needed.
2. Any exposed threads (male or female) must be cleaned and lubricated regularly, and protected from damage. Lubricate w/light machine oil.
3. If a ram has been exposed to rain, snow, sand, airborne abrasive, or any corrosive environment it must be cleaned, lubricated, and protected immediately after exposure. Daily clean exposed ram with clean cloth dampened with light machine oil. Protect exposed ram from the elements at all times.

Periodic Cleaning

Keep the hydraulic system as free of dirt as possible. When not in use, couplers must be sealed with dust covers. **All hose connections must be free of dirt and grime.** Any equipment attached to the ram must be kept clean. Use only Hein-Werner HW93291 or equivalent hydraulic fluid and change as recommended or sooner if the fluid becomes contaminated (never exceed 400 hours). Follow pump manufacturers instructions for changing and adding hydraulic fluid.

Storage

Ram should be stored in the plastic case with the ram end down in a dry, protected area, not exposed to corrosive vapor, dust or other harmful elements. When ram has not been used for a period of 4 months it should be connected to a pump and fully extended and then retracted a minimum of 5 times. This cycle will lubricate the cylinder wall, reducing the possibility of corrosion and damage there of.

How to remove faulty coupler

If ram does not retract, secure load by other means. Open release valve of host pump to depressurize pump, hose and coupler. Prevent ram from retracting (do not attempt to grasp with pliers or wrench without first wrapping the jaws of such tool with rags or similar padding). Disconnect and renew or replace coupler.

TROUBLESHOOTING

Symptom	Possible Causes	Corrective Action
Erratic action	<ul style="list-style-type: none"> • Air in system or pump cavitation • External leakage in flat body rams • Ram sticking or binding 	<ul style="list-style-type: none"> • Follow pump instructions for bleeding air • Contact Service Center • Contact Service Center
Ram does not move	<ul style="list-style-type: none"> • Loose couplers • Faulty coupler • Improper valve position • Low or no hydraulic fluid in pump reservoir • Air-locked pump • Pump not operating • Load is above the capacity of the system 	<ul style="list-style-type: none"> • Tighten couplers • Replace both female and male couplers • Close release valve or change pump position • Fill and bleed the system • Prime pump per pump operating instructions • Check pump's operating instructions • Use the correct equipment
Ram extends only partially	<ul style="list-style-type: none"> • Pump reservoir is low on hydraulic fluid • Load is above the capacity of the system • Ram is sticking or binding 	<ul style="list-style-type: none"> • Fill and bleed the system • Use the correct equipment • Contact Service Center
Ram moves slower than normal	<ul style="list-style-type: none"> • Loose connection or coupler • Restricted hydraulic line or fitting • Pump not working correctly • Ram seals leaking 	<ul style="list-style-type: none"> • Tighten connection or coupler • Clean and replace if damaged • Check pump operating instructions • Replace ram
Ram moves but does not maintain pressure	<ul style="list-style-type: none"> • Ram seals leaking • Pump or valve malfunctioning 	<ul style="list-style-type: none"> • Replace ram • Check pump operating instructions
Ram leaks hydraulic fluid	<ul style="list-style-type: none"> • Worn or damaged seals 	<ul style="list-style-type: none"> • Replace ram
Ram will not retract or retracts slower than normal	<ul style="list-style-type: none"> • Pump release valve closed • Loose couplers • Weak or broken retraction springs • Ram damaged internally • Pump reservoir too full 	<ul style="list-style-type: none"> • Open pump release valve • Tighten couplers • Replace ram • Replace ram • Drain hydraulic fluid to correct level

REPLACEMENT PARTS

Available Parts: Please refer to the Parts drawing when ordering parts. Not all components of the cylinders are replacement items, but are illustrated as a convenient reference of location and position in the assembly sequence. When ordering parts, give Model number, serial number and description below. Call or write for current pricing: SFA Companies 10939 N. Pomona Ave. Kansas City, MO 64153, U.S.A.
 Tel:(816)891-6390 Fax:(816)891-6599 E-Mail: sales@blackhawk-automotive.com

Model B65139 Replacement Parts

Item #	Part #	Description	Qty.
1	H23-6-2102-105	Upper Bearing	1
2	N/A	Plunger	1
3	644-1-0040-103	Bolt	1
4	H23-3-2100-103	Return Spring	1
5	H23-3-9901-102	Repair Kit (O-ring, Back-up Ring and Special Washer)	-
6	614-1-0040-109	Bolt	1
7	N/A	Base	1
8	H20-6-6008-102	Bushing	1
9	B69477	Female Coupler Assy. (1/4" NPTF)	1
10	H23-3-1001-106	Magnetic Adapter I (0.25")	1
11	H23-3-1002-108	Magnetic Adapter II (0.5")	1
12	H23-3-1003-100	Magnetic Adapter III (1")	1
13	H23-3-1004-102	Magnetic Adapter IV (1.25")	1
14	H23-6-7101-108	Plastic Case	1
-	B65139-L0	Label (not shown)	-
-	B65139-M0	Manual	-

N/A - Part is not available

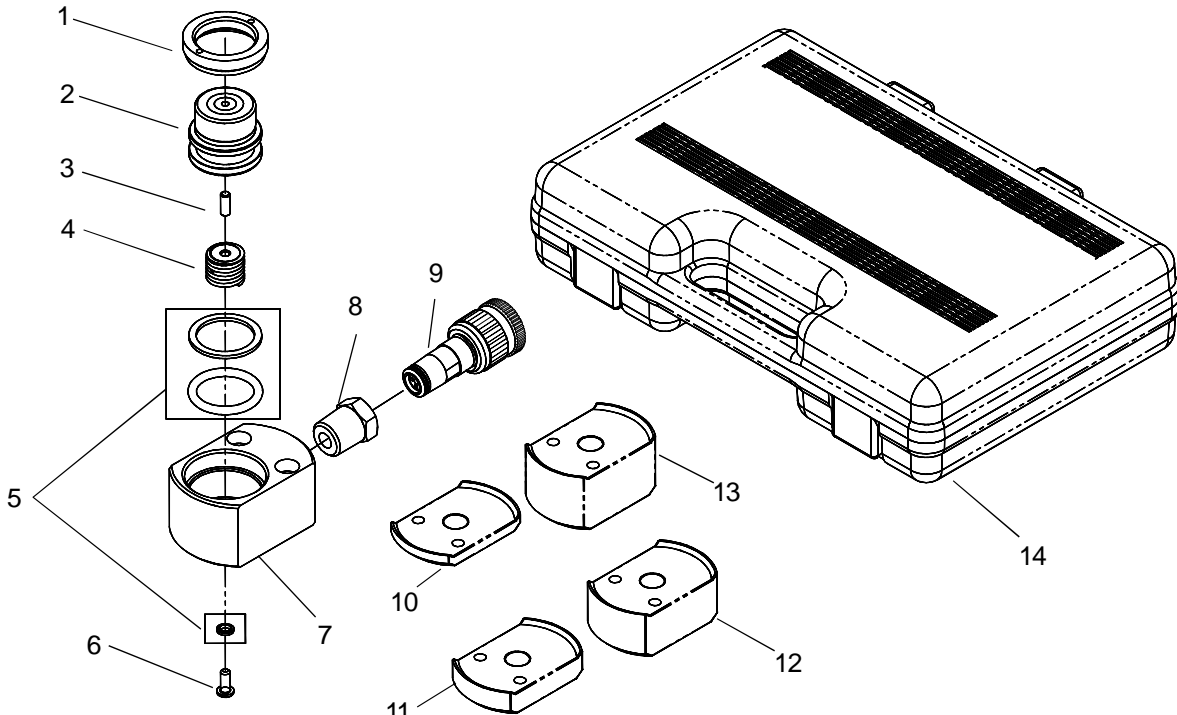

Figure 2 - Replacement Parts Illustration

ONE YEAR LIMITED WARRANTY

For a period of one (1) year from date of purchase, SFA Companies will repair or replace, at its option, without charge, any of its products which fails due to a defect in material or workmanship under normal usage. This limited warranty is a consumer's exclusive remedy.

Performance of any obligation under this warranty may be obtained by returning the warranted product, freight prepaid, to SFA Companies Warranty Service Department, 10939 N. Pomona Ave., Kansas City, MO 64153.

Except where such limitations and exclusions are specifically prohibited by applicable law.

(1) THE CONSUMER'S SOLE AND EXCLUSIVE REMEDY SHALL BE THE REPAIR OR REPLACEMENT OF DEFECTIVE PRODUCTS AS DESCRIBED ABOVE.

(2) SFA COMPANIES SHALL NOT BE LIABLE FOR ANY CONSEQUENTIAL OR INCIDENTAL DAMAGE OR LOSS WHATSOEVER.

(3) ANY IMPLIED WARRANTIES, INCLUDING WITHOUT LIMITATION THE IMPLIED WARRANTIES OF MERCHANTABILITY AND FITNESS FOR A PARTICULAR PURPOSE, SHALL BE LIMITED TO ONE YEAR, OTHERWISE THE REPAIR, REPLACEMENT OR REFUND AS PROVIDED UNDER THIS EXPRESS LIMITED WARRANTY IS THE EXCLUSIVE REMEDY OF THE CONSUMER, AND IS PROVIDED IN LIEU OF ALL OTHER WARRANTIES, EXPRESS OR IMPLIED.

(4) ANY MODIFICATION, ALTERATION, ABUSE, UNAUTHORIZED SERVICE OR ORNAMENTAL DESIGN VOIDS THIS WARRANTY AND IS NOT COVERED BY THIS WARRANTY.

Some states do not allow limitations on how long an implied warranty lasts, so the above limitation may not apply to you. Some states do not allow the exclusion or limitation of incidental or consequential damages, so the above limitation or exclusion may not apply to you. This warranty gives you specific legal rights, and you may also have other rights which vary from state to state.



SFA Companies
10939 N. Pomona Ave. Kansas City, MO 64153
816-891-6390
sales@blackhawk-automotive.com