



Porto-Power Blackhawk Automotive is a licensed trademark

# Pull Rams

## Operating Instructions & Parts Manual

Model Number	Capacity
B65143	2 Ton
B65454	5 Ton

SFA Companies  
10939 N. Pomona Ave. Kansas City, MO 64153  
816-891-6390  
[sales@blackhawk-automotive.com](mailto:sales@blackhawk-automotive.com)

- Before using this product, read this manual and follow all its Safety Rules and Operating Instructions

Made in Taiwan  
B65143-M0 rev 06/07

## ONE YEAR LIMITED WARRANTY

For a period of one (1) year from date of purchase, SFA Companies will repair or replace, at its option, without charge, any of its products which fails due to a defect in material or workmanship under normal usage. This limited warranty is a consumer's exclusive remedy.

Performance of any obligation under this warranty may be obtained by returning the warranted product, freight prepaid, to SFA Companies Warranty Service Department, 10939 N. Pomona Ave., Kansas City, MO 64153.

Except where such limitations and exclusions are specifically prohibited by applicable law.

(1) THE CONSUMER'S SOLE AND EXCLUSIVE REMEDY SHALL BE THE REPAIR OR REPLACEMENT OF DEFECTIVE PRODUCTS AS DESCRIBED ABOVE.

(2) SFA COMPANIES SHALL NOT BE LIABLE FOR ANY CONSEQUENTIAL OR INCIDENTAL DAMAGE OR LOSS WHATSOEVER.

(3) ANY IMPLIED WARRANTIES, INCLUDING WITHOUT LIMITATION THE IMPLIED WARRANTIES OF MERCHANTABILITY AND FITNESS FOR A PARTICULAR PURPOSE, SHALL BE LIMITED TO ONE YEAR, OTHERWISE THE REPAIR, REPLACEMENT OR REFUND AS PROVIDED UNDER THIS EXPRESS LIMITED WARRANTY IS THE EXCLUSIVE REMEDY OF THE CONSUMER, AND IS PROVIDED IN LIEU OF ALL OTHER WARRANTIES, EXPRESS OR IMPLIED.

(4) ANY MODIFICATION, ALTERATION, ABUSE, UNAUTHORIZED SERVICE OR ORNAMENTAL DESIGN VOIDS THIS WARRANTY AND IS NOT COVERED BY THIS WARRANTY.

Some states do not allow limitations on how long an implied warranty lasts, so the above limitation may not apply to you. Some states do not allow the exclusion or limitation of incidental or consequential damages, so the above limitation or exclusion may not apply to you. This warranty gives you specific legal rights, and you may also have other rights which vary from state to state.

## SAVE THESE INSTRUCTIONS

For your safety, read and understand the information contained within. The owner and operator shall have an understanding of this product and safe operating procedures before attempting to use this product. Instructions and safety information shall be conveyed in the operator's native language before use of this product is authorized. Make certain that the operator thoroughly understands the inherent dangers associated with the use and misuse of the product. If any doubt exists as to the safe and proper use of this product as outlined in this factory authorized manual, remove from service immediately. **Inspect before each use.** Do not use if broken, bent, cracked or otherwise damaged parts are noted. If any component of this product has been or suspected to have been subjected to a shock load (a load dropped suddenly, unexpectedly upon it), discontinue use until checked out by a Porto-Power Blackhawk Automotive Authorized Service Center. Owners and operators of this equipment shall be aware that the use and subsequent repair of this equipment may require special training and knowledge. It is recommended that an annual inspection be done by qualified personnel and that any missing or damaged parts, decals, warning / safety labels or signs be replaced with factory authorized replacement parts only. Any ram that appears to be damaged in any way, is worn or operates abnormally shall be removed from service immediately until such time as it can be repaired or replaced.

## PRODUCT DESCRIPTION

Porto-Power Blackhawk Automotive Pull Rams are engineered to meet or exceed ANSI B30.1 Standards for Performance and Safety. These rams are designed for rated capacity pulling jobs. A wide variety of applications exist for this category of product. Special skill, knowledge and training may be required for a specific task and the product may not be suitable for all the jobs described above. Unsuitable applications would include applications that call for a device to move, level or support persons, animals, hazardous materials, mobile homes / dwellings in general, mirrors and/or plate glass, and/or to connect/secure hatches, components, etc. between bulkheads. The user must make the decision regarding suitability of the product for any given task and therefore accept responsibility for that decision.

\* Maximum Operating Pressure 10,000 PSI.

**⚠ WARNING:** To reduce the risk of personal injury and/or property damage, ensure that the rated working pressure of each pressurized attachment be equal to or greater than the rated working pressure developed by the hydraulic pump.

**Note:** Always check connections before using. Alteration of these products is strictly prohibited.

## SPECIFICATIONS

Model Number	Ram Capacity (tons)	Stroke (in)	Ram Effective Area (in <sup>2</sup> )	Oil Capacity (in <sup>3</sup> )	Collapsed Height (in)	Extended Height (in)	Weight (lbs)	Pressure at Rated Cap. (psi)
B65143	2	5	0.56	2.8	10.28	15.28	6.0	7150
B65454	5	5.5	1.14	6.33	11.93	17.48	11.9	8780

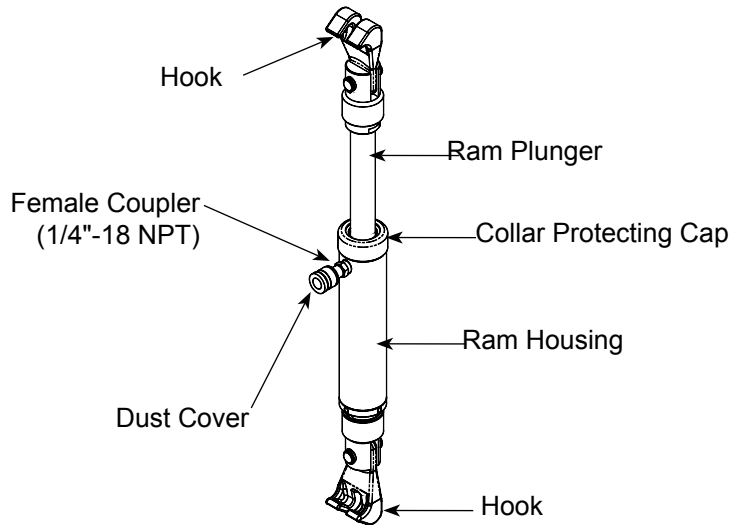

Figure 1- Typical Pull Ram Components (B65454 shown)

## SAFETY INSTRUCTIONS

### BEFORE USE

1. Before using this product, read the owner's manual completely and familiarize yourself thoroughly with the product, its components and recognize the hazards associated with its use.
2. Verify that the product and the application are compatible. Inspect before each use. Do not use if bent, broken, leaking or damaged components are noted.
3. Carefully remove the dust covers and plugs from hose coupler and ram coupler.
4. Connect hose coupler to ram coupler, ensure that there are no fluid leaks.
5. Check for leaks in system and have repaired by qualified personnel as needed. Before repairs are made, depressurize ram.
6. Replace worn or damaged parts and assemblies with Porto-Power Blackhawk Automotive Authorized Replacement Parts only (See Replacement Parts Section). Lubricate as instructed in Maintenance Section.
7. Use adequate eye protection when operating or near this equipment.
8. Ensure method of confirming load is accurate and working properly. Have gauge or load cell accuracy verified by qualified personnel on a yearly basis.
9. Rams should be stored where protected from the elements, abrasive dust, and damage. These rams should be stored in the vertical position.

### SET UP

**IMPORTANT!** Use an approved, high-grade pipe sealant to seal all hydraulic connections.

1. Remove the dust caps and plugs from coupler.
2. Inspect all threads and fittings for signs of wear or damage, and replace as needed.
3. Clean all threads and fittings.
4. Connect hydraulic hose from the hydraulic pump to the ram coupler. Ensure that there are no fluid leaks.
5. Install pressure gauge in-line from the pump for better control and safety purpose.
6. Tighten all connections securely but do not overtighten.
7. Check for leaks in system and have repaired by qualified personnel as needed. Before repairs are made, depressurize ram.

**Note:** The use of ram attachments or extensions reduces the ram capacity by at least 50%

# ⚠ WARNING



- Study, understand, and follow all instructions provided with and on this device before use.
- All WARNING statements must be carefully observed to help prevent personal injury.
- No alteration shall be made to this device.
- Failure to heed these warnings may result in personal injury as well as property damage.
- Always wear protective gear when operating hydraulic equipment.
- Keep hydraulic equipment away from flames and heat. Hydraulic fluid can ignite and burn. Do not operate if leaks are detected.
- **Crush Hazard.** Keep hands and feet away from loading area. Avoid pinch points or crush points that can be created by the load or parts of ram.
- To avoid crushing and related injuries:  
NEVER work on, under or around a lifted load before it is properly supported by appropriate mechanical means. Never rely on hydraulic pressure alone to support load.

## HYDRAULIC RAMS

- The user must be a qualified operator familiar with the correct operation, maintenance, and use of rams. Lack of knowledge in any of these areas can lead to personal injury.
- Do not exceed rated capacity of the ram or any equipment in the system.
- Burst hazard exists if hose or connection pressure exceeds rated pressure.
- Inspect ram, hoses and connections before each use to prevent unsafe conditions from developing. Do not use if they are damaged, altered or in poor condition. Do not use a ram with bent or damaged coupler or damaged threads.
- Use gauge or other load measuring instrument to verify load.
- Do not subject the ram to shock loads.
- Never attempt to disconnect hydraulic connections under pressure.
- Use only approved accessories and approved hydraulic fluid.
- Under certain conditions, the use of an extension with a hydraulic ram may not be advisable and could present a dangerous condition.
- To help prevent material fatigue if the ram is to be used in a continuous application, the load should not exceed 85% of the rated capacity.
- Ram must be on a stable base which is able to support the load while pulling or lifting. Ensure ram is fully engaged into/onto adapters, extension accessories.
- To help prevent personal injury, use shims, friction material or constraints to prevent slippage of the base or load.

- Distribute the load evenly across the entire saddle surface. Do not off-center loads on a ram. The load can tip or the ram can “kick out” and cause personal injury.
- This device is not suitable for use as support device! As the load is lifted, use blocking and cribbing to guard against a falling load.
- All personnel must be clear before lowering.
- Never try to disassemble a hydraulic ram, refer repairs to qualified, authorized personnel.

## HYDRAULIC HOSES & FLUID TRANSMISSION LINES

- Avoid short runs of straight line tubing. Straight line runs do not provide for expansion and contraction due to pressure and/or temperature changes.
- Reduce stress in tube lines. Long tubing runs should be supported by brackets or clips. Before operating the pump, tighten all hose connections with proper tools. Do not overtighten. Connections should only be tightened securely and leak-free. Overtightening can cause premature thread failure or high pressure fittings to burst.
- Should a hydraulic hose ever rupture, burst or need to be disconnected, immediately shut off the pump and release all pressure. Never attempt to grasp a leaking pressurized hose with your hands. The force of escaping hydraulic fluid can inflict injury.
- Do not subject the hose to potential hazard such as fire, sharp objects, extreme heat or cold, or heavy impact.
- Do not allow the hose to kink, twist, curl, crush, cut or bend so tightly that the fluid flow within the hose is blocked or reduced. Periodically inspect the hose for wear, because any of these conditions can damage the hose and possibly result in personal injury.
- Do not pull, position or move setup by the hose. Doing so can damage the hose and possibly cause personal injury.
- Hose material and coupler seals must be compatible with hydraulic fluid used. Hoses also must not come in contact with corrosive materials such as battery acid, creosote-impregnated objects and wet paint. Hose deterioration due to corrosive material can result in personal injury. Never paint a coupler or hose.

## IMPORTANT

- Keep ram clean at all times. When the ram is not in use, keep the plunger fully retracted.
- Use an approved, high-grade pipe thread sealant to seal all hydraulic connections. Teflon tape can be used if only one layer of tape is used and it is applied carefully (two threads back) to prevent the tape from being introduced into hydraulic system. A piece of tape could travel through the system and obstruct the flow of fluid and adversely affect function.
- Never attach ANY component not authorized by manufacturer.
- Never use other than factory provided and/or authorized fasteners.

## KNOW YOUR SYSTEM

Your ram, hose(s), couplings and pump all must be rated for the same maximum operating pressure, correctly connected and compatible with the hydraulic fluid used. An improperly matched system can cause the system to fail and possibly cause serious injury.

## OPERATION

Operate the hydraulic pump to retract and advance the ram.

**Note:** Do not continue pumping when ram is fully retract or extend. Internal pressure will build up and may damage the seal of the ram.

## MAINTENANCE

1. Inspect hoses and connections daily. Replace damaged components immediately with Williams Replacement Parts only.
2. Tighten connections as needed. Use pipe thread sealing compound when servicing connections.
3. Always use clean, approved hydraulic fluid and change as recommended or sooner if the fluid becomes contaminated (never exceed 400 hours). Follow pump manufacturers instructions for changing and adding hydraulic fluid. Use only good quality hydraulic fluid. We recommend Hein-Werner HW93291 or equivalent when using with hand pump or air pump; Mobil DTE 15M or equivalent when using with electric pump. **Never** use brake fluid, transmission fluid, turbine oil, motor oil, alcohol, glycerin etc. Use of other than good quality hydraulic oil will void warranty and damage the cylinder, pump, hose etc.

### Lubrication & Cleaning

1. Any exposed threads (male or female) must be cleaned and lubricated regularly, and protected from damage. Lubricate with light machine oil.
2. If a cylinder or ram has been exposed to rain, snow, sand, airborne abrasive, or any corrosive environment, it must be cleaned, lubricated, and protected immediately after exposure. Daily clean exposed ram with clean cloth dampened with light machine oil. Protect exposed ram from the elements at all times.

### Storage

Cylinders should be store in vertical position in a dry, protected area, not exposed to corrosive vapor, dust or other harmful elements. When a cylinder has not been used for a period of 4 months, it should be connected to a pump and fully retracted and then extended a minimum of 5 times. This cycle will lubricate the cylinder wall, reducing the possibility of corrosion and damage there of.

### How to remove faulty coupler:

If cylinder does not retract, secure load by other means. Depressurize pump and hose. To avoid hydraulic oil from spilling, wrap the grasping tool with rags or similar padding. Remove the cylinder from application. Disconnect and replace with new coupler.

### How to bleed air from system:

Place pump at a higher elevation than the hose and cylinder as shown in figure 2 below. Operate pump to fully retract and advance the cylinder 2 or 3 times. The objective is to "float the air bubbles up hill and back to the pump reservoir. Follow pump instruction manual to bleed the air from pump reservoir. On most pump, pressurized air can be escaped by simply opening the oil filler plug/screw.

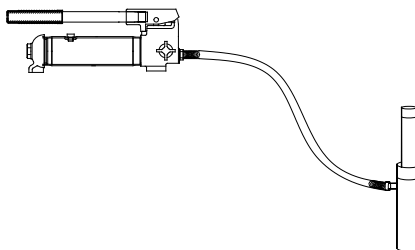

Figure 2 - Illustration to bleed air from system

## TROUBLESHOOTING GUIDE

The following information is intended as an aid in determining if problem exists. For repair service, contact Porto-Power authorized service center in your area.

Symptom	Possible Causes	Corrective Action
Erratic action	<ul style="list-style-type: none"> <li>• Air in system or pump cavitation.</li> <li>• External leakage in ram.</li> <li>• Ram sticking or binding.</li> </ul>	<ul style="list-style-type: none"> <li>• Vent the system. (refer to figure 2)</li> <li>• Contact service center.</li> <li>• Contact service center.</li> </ul>
Ram will not retract, or respond to pressurized fluid	<ul style="list-style-type: none"> <li>• Overload condition.</li> <li>• Loose couplers.</li> <li>• Faulty couplers.</li> <li>• Oil level in pump is low.</li> <li>• Pump not operating.</li> <li>• Air-locked pump.</li> </ul>	<ul style="list-style-type: none"> <li>• Remedy overload condition.</li> <li>• Tighten couplers.</li> <li>• Replace both female and male couplers.</li> <li>• Fill and bleed the system.</li> <li>• Check pump's operating instructions.</li> <li>• Prime pump per pump operating instructions.</li> </ul>
Ram retracts only partially	<ul style="list-style-type: none"> <li>• Oil level in pump is low.</li> <li>• Overload condition.</li> <li>• Ram is sticking or binding</li> </ul>	<ul style="list-style-type: none"> <li>• Fill and bleed the system.</li> <li>• Remedy overload condition.</li> <li>• Contact service center.</li> </ul>
Ram moves slower than normal	<ul style="list-style-type: none"> <li>• Loose connection or coupler.</li> <li>• Restricted hydraulic line or fitting.</li> <li>• Pump not working correctly.</li> <li>• Ram seals leaking.</li> </ul>	<ul style="list-style-type: none"> <li>• Tighten connection or coupler.</li> <li>• Clean and replace if damaged.</li> <li>• Check pump's operating instructions.</li> <li>• Contact service center.</li> </ul>
Ram responds to pressurized fluid, but system does not maintain pressure	<ul style="list-style-type: none"> <li>• Overload condition.</li> <li>• Pump or valve malfunctioning.</li> <li>• Ram seals leaking.</li> </ul>	<ul style="list-style-type: none"> <li>• Remedy overload condition.</li> <li>• Check pump's operating instructions.</li> <li>• Contact service center.</li> </ul>
Oil leaks from ram	<ul style="list-style-type: none"> <li>• Worn or damaged seals.</li> </ul>	<ul style="list-style-type: none"> <li>• Contact service center.</li> </ul>
Ram will not extend or extends slower than normal	<ul style="list-style-type: none"> <li>• Malfunctioning coupler, damaged application.</li> <li>• Pump reservoir overfilled.</li> <li>• Ram damage internally</li> </ul>	<ul style="list-style-type: none"> <li>• <b>Secure load by other means. Depressurize</b> pump and hose, remove application and replace coupler.</li> <li>• <b>Secure load by other means. Depressurize</b> pump and hose, remove application, then drain fluid to proper level.</li> <li>• Contact service center.</li> </ul>
Ram will not fully retract	<ul style="list-style-type: none"> <li>• Oil level in pump is low.</li> </ul>	<ul style="list-style-type: none"> <li>• <b>Secure load by other means. Depressurize</b> pump and hose, remove application, then add fluid to proper level.</li> </ul>
Poor performance	<ul style="list-style-type: none"> <li>• Oil level in pump is low.</li> <li>• Air trapped in system.</li> </ul>	<ul style="list-style-type: none"> <li>• Ensure proper oil level.</li> <li>• Vent the system. (refer to figure 2)</li> </ul>

# REPLACEMENT PARTS

Not all components of the rams are replacement items, but are illustrated as a convenient reference of location and position in the assembly sequence. When ordering parts, give model number, serial number and description below. Call or write for current pricing: SFA Companies 10939 N. Pomona Ave. Kansas City, MO 64153, U.S.A. Tel:(816)891-6390 Fax:(816)891-6599 E-Mail: sales@blackhawk-automotive.com.

## Replacement Parts For Model B65143:

Item#	Part#	Description	Qty.
1	N/A	Plunger	1
2	H29-6-1804-104	Upper Bearing	1
3	*	Dust Seal	1
4	N/A	Cylinder	1
5	*	Back-up Ring	1
6	*	U-cup	1
7	*	U-cup	1
8	*	Back-up Ring	1
9	H05-6-1204-106	Bearing	1
10	H29-3-1403-108	Spring Guide Rod	1
11	511-2-0069-118	Compression spring	1
12	511-2-0125-112	Compression spring	1
13	H29-6-1204-100	Lower Bearing	1
14	B69477	Female Coupler Assy. (1/4" NPT)	1
15	H05-6-2305-107	Protecting Cap	1
16	H29-3-2810-106	Hook Assembly (Top)	1
17	H29-3-1811-108	Hook Assembly (Bottom)	1
(*)	H29-3-9901-104	Repair Kit	-
-	B65143-L0	Label	-
-	B65143-M0	Manual	-

\* - Repair Kit includes item# 3, 5, 6, 7, 8  
 N/A - Part is not available

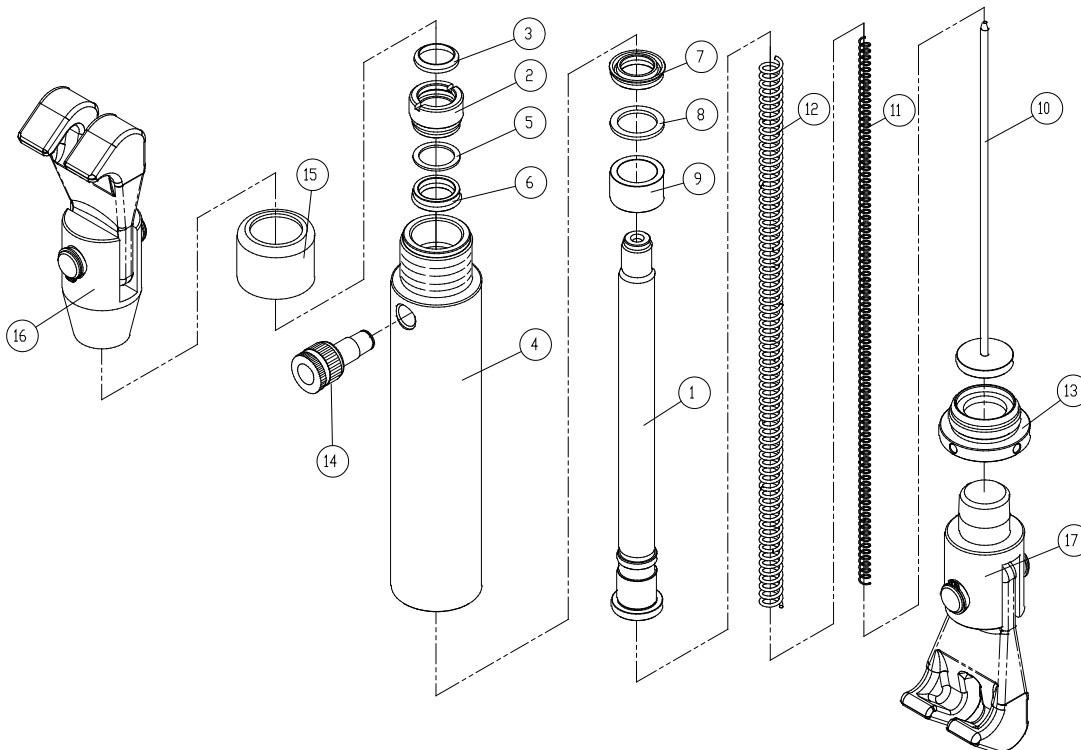

Figure 3 - Replacement Parts Illustration for Model B65143

**Replacement Parts For Model B65454:**

Item#	Part#	Description	Qty.
1	N/A	Cylinder	1
2	N/A	Plunger	1
3	*	Dust Seal	1
4	H21-6-1804-108	Upper Bearing	1
5	*	Back-up ring	1
6	*	U-cup	1
7	*	U-cup	1
8	*	Back-up ring	1
9	H10-5-1204-109	Bearing	1
10	511-2-0125-103	Compression Spring	1
11	511-2-0200-101	Compression Spring	1
12	H21-3-1403-102	Spring Guide Rod	1
13	H21-5-1204-108	Lower Bearing	1
14	H20-6-6008-102	Bushing	1
15	B69477	Female Coupler Assy. (1/4" NPT)	1
16	H21-6-2812-102	Adapter	1
17	H21-5-2305-109	Protecting Cap	1
18	B65535	Connector	1
19	B65649	Hook Assembly	2
(*)	H21-3-9910-109	Repair Kit	-
-	B65454-L0	Label	-
-	B65143-M0	Manual	-

\* - Repair Kit includes item# 3, 5, 6, 7, 8  
 N/A - Part is not available

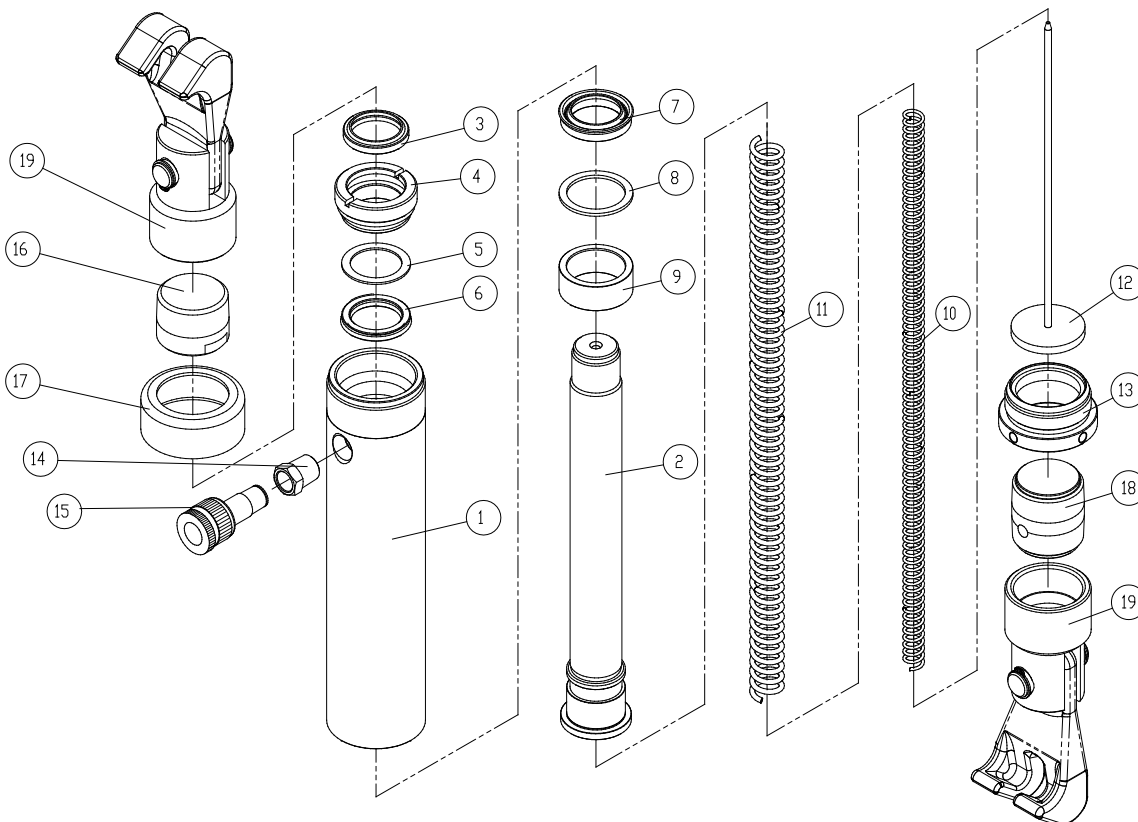

Figure 4 - Replacement Parts Illustration for Model B65454