



**Blackhawk
Automotive™**

Blackhawk Automotive is a Licensed Trade Mark

Made by SFA Companies, Kansas City, MO

Magic Lift™ Long Chassis Service Jacks

Operating Instructions & Parts Manual

Model	Capacity
BH6057	5 Ton
BH6107	10 Ton

SFA Companies
10939 N. Pomona Ave. Kansas City, MO 64153
sales@blackhawk-automotive.com

- Before using this product, read this manual and follow all its Safety Rules and Operating Instructions

Made in PRC
BH6057-M0 rev 05/07

Save these instructions. For your safety, read, understand, and follow the information provided with and on this jack. The owner and operator shall have an understanding of this jack and safe operating procedures before attempting to use. The owner and operator shall be aware that use and repair of this product may require special skills and knowledge. Instructions and safety information shall be conveyed in the operator's native language before use of this jack is authorized. If any doubt exists as to the safe and proper use of this jack, remove from service immediately. **Inspect before each use.** Do not use if broken, bent, cracked, or damaged parts (including labels) are noted. Any jack that appears damaged in any way, operates abnormally or is missing parts, shall be removed from service immediately. If the jack has been or suspected to have been subjected to a shock load (a load dropped suddenly, unexpectedly upon it), immediately discontinue use until jack has been checked by a Blackhawk authorized service center. It is recommended that an annual inspection be done by qualified personnel. Replace worn or damaged parts and assemblies with Blackhawk Authorized Replacement Parts only. Labels and Operator's Manuals are available from manufacturer.

PRODUCT DESCRIPTION

Blackhawk Magic Lift™ Long Chassis Hydraulic Service Jacks are designed to lift, **not** sustain, rated capacity loads. They are designed to be used in conjunction with jack stands. Magic Lift™ service jacks have a unique feature which automatically provide fast, no load lifts to the jacking point. **Intended use:** To lift one axle of a vehicle for the purpose of service and/or repair of vehicle components. After lifting, loads must be immediately supported by appropriately rated jack stands. Check with vehicle owner's manual for proper lift points.

DO NOT USE TO DOLLY OR MOVE VEHICLE. DO NOT USE FOOT PEDAL TO RAISE LOAD!

SPECIFICATIONS

Model	Capacity	Jack Size (L x W x H)	Min. Height	Max. Height	Saddle Dia.	Volume of Hyd Oil
BH6057	5 Ton	52 5/8" x 16 7/8" x 11"	6 1/2"	22 1/4"	6 1/2"	670 mL
BH6107	10 Ton	55 7/8" x 19 5/8" x 9 5/8"	6 7/8"	27"	6 1/2"	900 mL

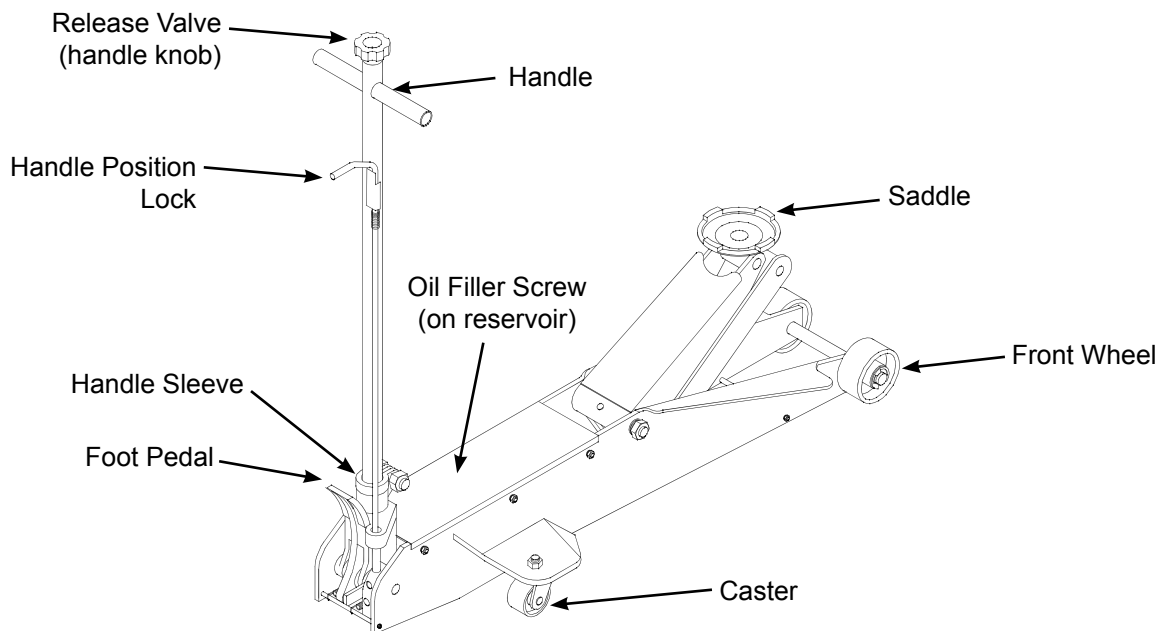



Figure 1 - Service Jack Components (BH6107 shown)

SAFETY INSTRUCTIONS

Before Use



1. Verify that the product and the application are compatible, if in doubt call Blackhawk Technical Service (816)891-6390.
2. Before using this product, read the operator's manual completely and familiarize yourself thoroughly with the product, its components and recognize the hazards associated with its improper use.
3. Always secure the handle into the handle sleeve by means of the bolt and lock washer provided. Tighten securely to prevent accidental removal of handle while in use
4. Open release valve by turning the handle knob counterclockwise (no more than 2 full turns).
4. With saddle fully lowered, locate and remove vent screw. Ensure that the oil level is just below the oil filler hole. Reinstall the ventscrew.
5. Check to ensure that jack rolls freely and the pump operates smoothly before putting into service.

 WARNING	
<ul style="list-style-type: none">• Study, understand, and follow all printed materials provided with/on this product before use.• Do not exceed rated capacity.• This is a lifting device only.• Use only on hard, level surfaces capable of supporting rated capacity loads.• After lifting, immediately transfer the load to appropriately rated vehicle stands.• Never work on, under, or around a load supported by this device only.• On air actuated model, never wire, clamp or otherwise disable the lift control valve to function by other than operator's hand.• Do not move or dolly loads with this device.• No alterations shall be made on this product.• Failure to heed these markings may result in personal injury and/or property damage.	

OPERATION

Lifting

 CAUTION
Always lift only on areas of the vehicle as specified by the vehicle manufacturer. Do not use adapters or accessories that are not provided initially.

 WARNING	
	To avoid crushing and related injuries: NEVER work on, under or around a load supported only by jack. ALWAYS use adequately rated jack stands.

1. Place vehicle in park, with emergency brake on and wheels securely chocked to prevent inadvertent vehicle movement.
2. Close release valve by turning handle knob clockwise firmly. Center jack saddle under lift point.
3. Verify lift point, then use handle pump or foot pedal to contact lift point. To lift, pump handle until load reaches desired height. Never use foot pedal to raise load.
4. Transfer the load immediately to appropriately rated jack stands.

Note: The jack is equipped with a handle position lock. To release lock device pull lever up, then back until lever is locked into place. This will allow full range of handle movement.

Lowering

 WARNING
Be sure all tools and personnel are clear before lowering load.

1. Raise load high enough to clear the jack stands, then carefully remove jack stands (**always** used in pairs).
2. Slowly turn the handle counterclockwise, but no more than 1/2 turn. If the load fails to lower:
 - a. Use another jack to raise the vehicle high enough to reinstall jack stands.
 - b. Remove the affected jack and then the stands.
 - c. Using the other jack, lower the load by turning the operating handle counterclockwise, but no more than 1/2 turn.
3. After removing jack from under the load, push saddle down to reduce ram exposure to rust and contamination.

MAINTENANCE

Important: Use only good grade hydraulic jack oil. Avoid mixing different types of fluid and **Never** use brake fluid, turbine oil, transmission fluid, motor oil or glycerin. Improper fluid can cause failure of the jack and the potential for sudden and immediate loss of load. We recommend Hein-Werner HW93291 or equivalent.

Adding oil

1. With saddle fully lowered set jack in its upright, level position. Locate and remove vent screw.
2. Fill with oil until ~3/16" above the inner cylinder as seen from the oil filler hole. Reinstall the vent screw.

Changing oil

For best performance, replace the complete fluid supply at least once per year.

1. With saddle fully lowered, remove the vent screw and drain the fluid into a suitable container.
2. Fill with oil until ~3/16" above the inner cylinder as seen from the oil filler hole. Reinstall the vent screw.

Note: Dispose of hydraulic fluid in accordance with local regulations.

Lubrication

A periodic coating of light lubricating oil to pivot points, axles and hinges will help to prevent rust and assure that wheels, casters and pump assemblies move freely. To help ensure trouble free operation, an inline air dryer and oiler is recommended on air operated model.

Cleaning

Periodically check the pump piston and ram for signs of rust/corrosion. Clean as needed and wipe with an oily cloth.

Note: Never use sandpaper or abrasive material on these surfaces!

Storage

When not in use, store the jack with saddle fully lowered.

TROUBLESHOOTING

Symptom	Possible Causes	Corrective Action
Jack will not lift load	<ul style="list-style-type: none">• Release valve not tightly closed• Overload condition• Air pressure inadequate	<ul style="list-style-type: none">• Ensure release valve tightly closed• Remedy overload condition• Ensure adequate air pressure
Jack will lift, but not maintain pressure	<ul style="list-style-type: none">• Release valve not tightly closed• Overload condition• Hydraulic unit malfunction	<ul style="list-style-type: none">• Ensure release valve tightly closed• Remedy overload condition• Contact Blackhawk Tech. Service
Jack will not lower after unloading	<ul style="list-style-type: none">• Reservoir overfilled• Linkage binding	<ul style="list-style-type: none">• Ensure load is removed, then drain fluid to proper level• Clean and lubricate moving parts
Poor lift performance	<ul style="list-style-type: none">• Fluid level low	<ul style="list-style-type: none">• Ensure proper fluid level
Will not lift to full extension	<ul style="list-style-type: none">• Fluid level low	<ul style="list-style-type: none">• Ensure proper fluid level

REPLACEMENT PARTS

Not all components of the jack are replacement items, but are illustrated as a convenient reference of location and position in the assembly sequence. When ordering parts, give Model number, serial number and parts description. Call or write for current pricing: SFA Companies, 10939 N. Pomona Ave. Kansas City, MO 64153, U.S.A. Tel:(816)891-6390 Fax:(816)891-6599 E-Mail: sales@blackhawk-automotive.com

Item	Part# for BH6057	Part# for BH6107	Description	Qty
1	G251-00002-000	G661-00012-000	Saddle	1
2	G250-90004-K01	G661-90009-K01	Front Wheel	2
3	G251-00003-000	G150-00005-000	Return Spring	2
4	G62S-03300-200		Vent Screw	1
5	G651-10000-000	G661-40000-000	Hydraulic Unit	1
6	G251-20004-000		Release Valve	1
7	G62S-90009-K01	G661-70000-000	Caster Assembly	2
8	G251-00004-000	G251-00004-000 (2pc.)	Return Spring	1
9	G251-00009-000		Foot Pedal	1
10a	G651-20000-000	N/A	Handle Assembly	1
10b	N/A	G661-90009-K02		
-	G6511S-077	G6610S-121	Repair Kit	-
-	BH6050-L0	BH6011-L0	Label (s)	-
-	BH6050-M0		Manual	-

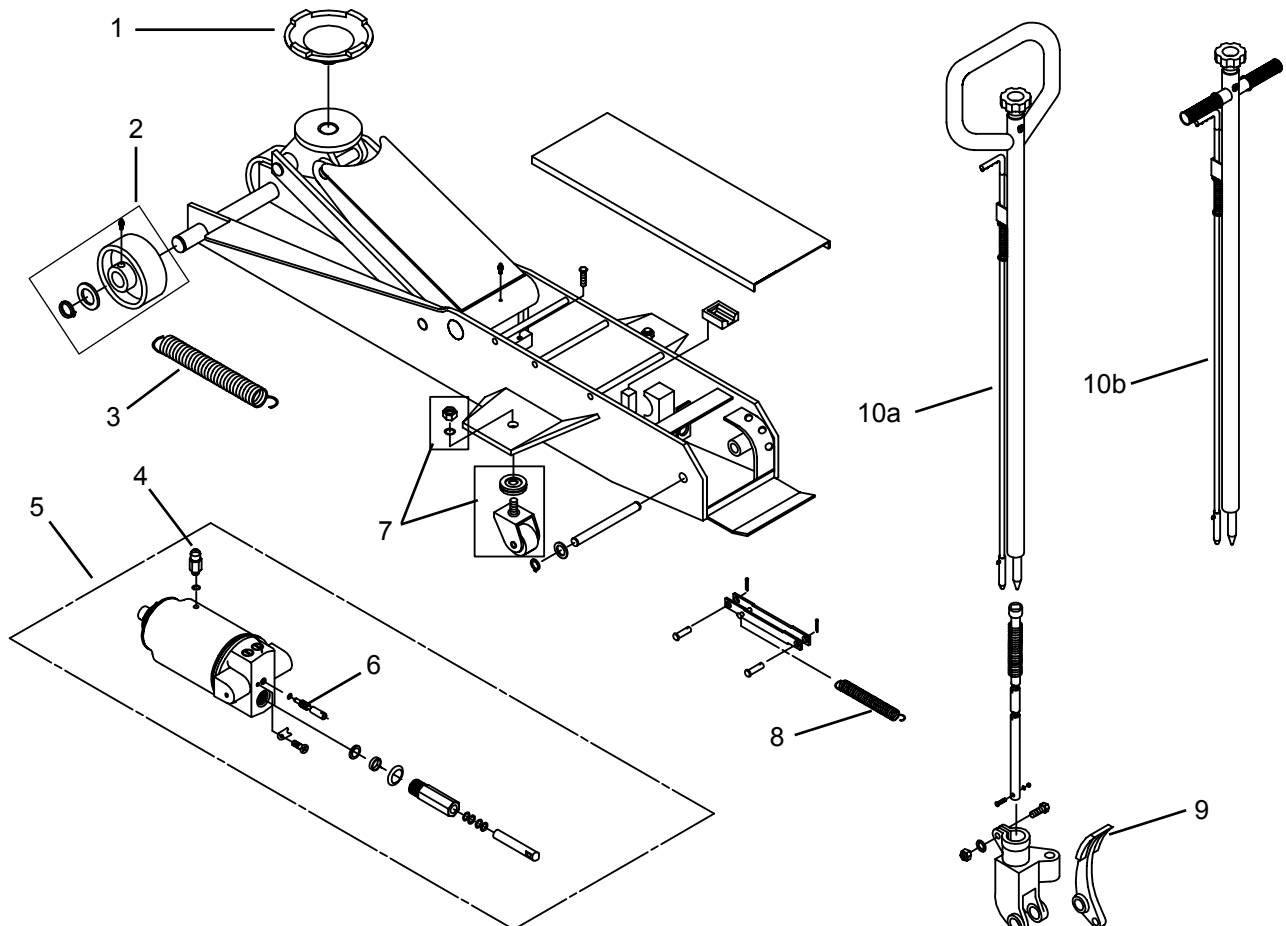

Figure 2 - Replacement Parts Illustration for Model BH6057 & BH6107



ONE YEAR LIMITED WARRANTY

For a period of one (1) year from date of purchase, SFA Companies will repair or replace, at its option, without charge, any of its products which fails due to a defect in material or workmanship under normal usage. This limited warranty is a consumer's exclusive remedy.

Performance of any obligation under this warranty may be obtained by returning the warranted product, freight prepaid, to SFA Companies Warranty Service Department, 10939 N. Pomona Ave., Kansas city, MO 64153. Except where such limitations and exclusions are specifically prohibited by applicable law.

(1) THE CONSUMER'S SOLE AND EXCLUSIVE REMEDY SHALL BE THE REPAIR OR REPLACEMENT OF DEFECTIVE PRODUCTS AS DESCRIBED ABOVE.

(2) SFA COMPANIES SHALL NOT BE LIABLE FOR ANY CONSEQUENTIAL OR INCIDENTAL DAMAGE OR LOSS WHATSOEVER.

(3) ANY IMPLIED WARRANTIES, INCLUDING WITHOUT LIMITATION THE IMPLIED WARRANTIES OF MERCHANTABILITY AND FITNESS FOR A PARTICULAR PURPOSE, SHALL BE LIMITED TO ONE YEAR, OTHERWISE THE REPAIR, REPLACEMENT OR REFUND AS PROVIDED UNDER THIS EXPRESS LIMITED WARRANTY IS THE EXCLUSIVE REMEDY OF THE CONSUMER, AND IS PROVIDED IN LIEU OF ALL OTHER WARRANTIES, EXPRESS OR IMPLIED.

(4) ANY MODIFICATION, ALTERATION, ABUSE, UNAUTHORIZED SERVICE OR ORNAMENTAL DESIGN VOIDS THIS WARRANTY AND IS NOT COVERED BY THIS WARRANTY.

Some states do not allow limitations on how long an implied warranty lasts, so the above limitation may not apply to you. Some states do not allow the exclusion or limitation of incidental or consequential damages, so the above limitation or exclusion may not apply to you. This warranty gives you specific legal rights, and you may also have other rights which vary from state to state.

SFA Companies
10939 N. Pomona Ave. Kansas City, MO 64153
816-891-6390
sales@blackhawk-automotive.com

