

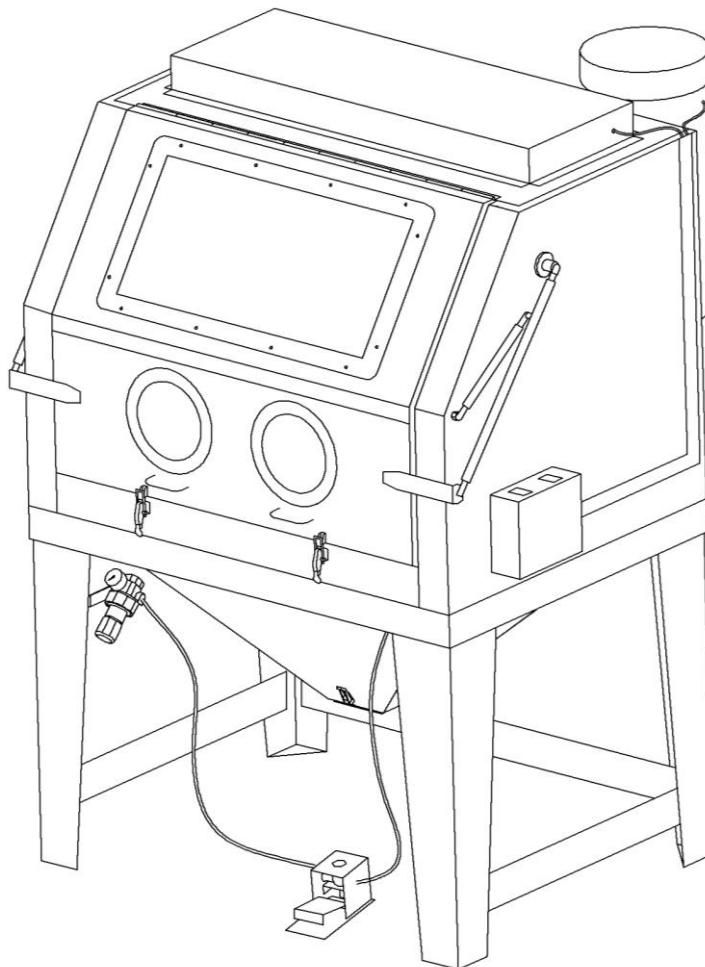

# ABRASIVE BLAST CABINET 41800

OPERATING AND MAINTENANCE INSTRUCTIONS



## CONTENTS

TECHNICAL SPECIFICATIONS	Pg 1
IMPORTANT WARNINGS	Pg 2-3
CABINET BLASTER SAFETY PROCEDURES	Pg 4
IMPORTANT INFORMATION	Pg 5
IMPORTANT NOTICES	Pg 6
ASSEMBLY INSTRUCTIONS	Pg 7-10
OPERATION INSTRUCTIONS	Pg 10
MAINTENANCE INSTRUCTIONS	Pg 10-11
MAINTAIN SUCTION EFFICIENCY WITH SIMPLE STEPS	Pg 11-12
RECOMMENDATIONS	Pg 13
REQUIREMENTS	Pg 14
MEDIA / ABRASIVES	Pg 15
CABINET PARTS DIAGRAM & PARTS LIST	Pg 16-19
DISCLAIMER & LIMITED WARRANTY	Pg 20

## TECHNICAL SPECIFICATIONS

Rating: 110~120V, **60 Hz, 1200W**

Maximum Work Pressure **110PSI**

Air Consumption: 7/32" Nozzle 15CFM at 80 PSI

9/32" Nozzle 20CFM at 80 PSI

Work Light:

Fluorescent Light: 4 Bulbs

Each Rating : 110~120V, **60 Hz, 26W**

Motor Rating: 110~120V, **60 Hz, 1200W**

Overall Dimensions: W52" x D47.2" x H69.3" (133x124x177cm)

Net Weight: 358 lbs.

Gross Weight: 443 lbs.

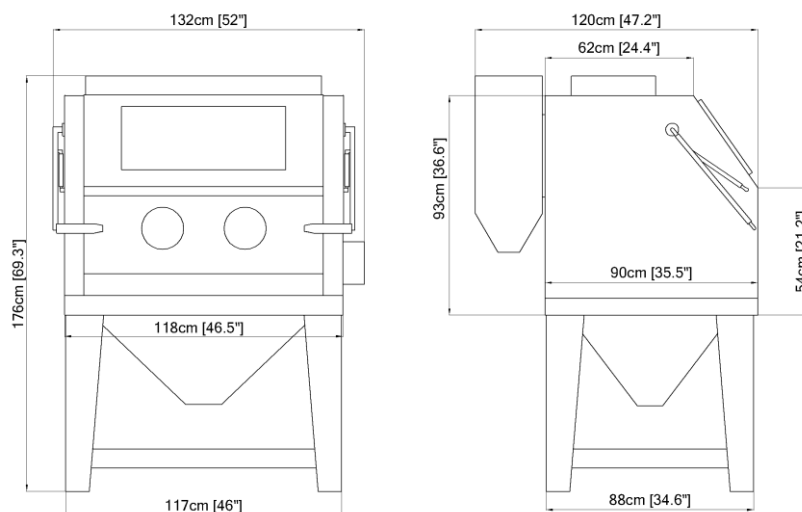

## **WARNING!**

Do not use a Cabinet Blaster until you have read this manual and you understand its contents and warnings. These warnings are included for the health and safety of the operator and those in the immediate vicinity. Keep this manual for future reference.

Dust created by power sanding, sawing, grinding, drilling, and other construction activities may contain chemicals known to cause cancer, birth defects or other reproductive harm and respiratory illnesses. Some examples of the chemicals include:

- Lead from lead based paints
- Crystalline silica from bricks, cement and other masonry products
- Arsenic and chromium from chemically-treated lumber

Your risk from these exposures varies, depending on how often you do this type of work. To reduce your exposure to these chemicals: Work in a ventilated area, and work with approved safety equipment specially designed to filter out microscopic particles.

Abrasive blasting produces harmful dust. Everyone in the blasting area must wear a properly fitted and properly maintained NIOSH approved air supplied respirator.

### **SILICOSIS AND OTHER DUST WARNINGS:**

Breathing dust from silica sand may cause silicosis, a fatal lung disease. Breathing dust during blasting operations may also cause asbestosis and/or other serious or fatal diseases. A NIOSH-approved, well maintained air supplied abrasive blasting respirator must be used by anyone blasting, anyone handling or using media containing toxic substances or media with more than point one percent (.001) free crystalline silica and anyone in the area of the dust. Harmful dust can remain suspended in the air for long periods of time after blasting has ceased, causing serious injury or death.

Before removing respirator, use an air monitoring instrument to determine if atmosphere is safe to breathe. Contact local OSHA or NIOSH office to determine the proper respirator for your particular application.

Air supplied respirators do not remove or protect against carbon monoxide (CO) or any other toxic gas. Use a carbon monoxide removal device and monitoring device with the respirator to ensure grade D quality air. Follow all applicable OSHA standards and OSHA regulation 1910.134 (d).

Do not use this equipment in any area that might be considered hazardous or where flammable gases or liquids are present. Failure to do so may cause an explosion resulting in serious injury.

## WARNING AND SAFETY INFORMATION

Do not operate cabinet or air flow with cabinet door  
Open or with cabinet lens removed.

Do not use fluids or mix fluids with blast media.  
This cabinet is designed for dry blasting only.

Do not exceed maximum operating pressure of **110** PSI.

### WARNING!

Disconnecting hose while Unit is under pressure could cause serious injury or death. Use safety lock pins and safety cables in all coupling connections to help prevent hose couplings from accidental disconnection.

### WARNING!

Failure to observe the following before performing any maintenance could cause serious injury or death from the sudden release of compressed air:

- Disconnect power supply
- Lockout and tagout the compressed air supply
- Bleed the air supply line to the blast gun.

Immediate replacement of worn components is required. Failure to replace worn components could expose the operator or bystanders to high speed media and compressed air could cause death or serious injury.

Leaks around couplings and nozzle holders indicate worn or loose fitting parts. Nozzle holders and couplings that do not fit tightly on hose and nozzles that do not fit tightly in nozzle holders could disconnect while under pressure. Impact from nozzles, couplings, hoses, or abrasive, and parts disconnected while under pressure could cause severe injury.

The threads on the nozzle holder must be inspected each time the nozzle is secured to the holder. Check the threads for wear, and make sure nozzle screw securely grips the nozzle. The nozzle washer must also be inspected for wear. Worn nozzle washers cause erosion. A loose-fitting nozzle may eject from the holder under pressure and could cause severe injury.

## **CABINET BLASTER SAFETY PROCEDURES**

**CAUTION: READ THESE SAFETY PROCEDURES IN THEIR ENTIRETY - PARTS OF THE OPERATING INSTRUCTIONS ARE WITHIN THESE WARNINGS.**

These procedures are not intended to be exhaustive due to the many variables in the abrasive blasting field. Therefore, we **INSIST** that the hands, ears, mouth, nose and eyes be covered with appropriate safety protection at all times.

### **ADDITIONAL WARNINGS! CAUTION MUST BE EXERCISED BY USER AT ALL TIMES**

- 1. Do not exceed maximum working pressure of 110 PSI. Failure to keep maximum working pressure below 110 PSI can cause the blast machine to burst, causing death or serious injury.**
- 2. Everyone in the blast area including the equipment operator should correctly use and maintain a NIOSH approved air supplied respirator, even after blasting has ceased. Harmful dust can remain suspended in the air for long periods of time after blasting has ceased causing injury or death.**
- 3. For safe operation, perform recommended preventive maintenance on blaster cabinet, and accessories. Replace all worn parts before they fail. Immediate replacement of worn components is required. Failure to replace worn components could result in exposing the operator or bystanders to high speed media and compressed air, causing serious injury.**
- 4. Do not use corrosive materials of any type in unit. Use only clean, dry media.**
- 5. Static electricity can be created by the use of this equipment. Don not use within fifty feet of any explosive, potentially explosive substances, or their vapors as an explosion can occur.**

## IMPORTANT INFORMATION

Read all instructions before using this equipment. Save these instructions for future reference.

Remember:

1. Start up preparations:
  - Supply air line should be sized appropriately. See page 14. All hoses should be rated at least **125 PSI** and an isolation valve should be installed so that supply air can be turned off and then disconnected from blast machine for servicing.
  - Supply air should be dry and clean from oil and other contaminants. (i.e. use air dryer, coalescent filter, or moisture separator as needed.)
  - Blast machine must be grounded to avoid shock.
  - Electric extension cords should be three wire grounded, and rated for the amperage of the blaster. Check nameplate for rated amps.
  
2. Operator's responsibilities before starting:
  - Inspect fittings and hoses for damage and wear.  
Check the seal on all doors. Only operate the blast cabinet with all doors securely closed and dust collection system running.
  - Clean dust from dust collector and clean filter as needed.
  
3. Caution:
  - Unless otherwise specified, working pressure of blast machine and related components must not exceed **110 PSI**.
  - Keep blast nozzle controlled and aimed at the work.
  
4. Maintenance:
  - Keep your machine in good repair. Use **ALLSOURCE** parts and do not substitute or modify **ALLSOURCE** supplied items.

## IMPORTANT NOTICE

TO DISTRIBUTORS, PURCHASERS AND END USERS OF **ALLSOURCE** PRODUCTS

The information provided described and illustrated in this material is intended for experienced, knowledgeable users of abrasive blasting equipment and supplies (products).

The products described in this material may be combined as determined solely by the user in a variety of way and purposes. However no representations are made as to intended use, performance standards, engineering suitability, safe practices or compliance with government regulation and laws that apply to these products, products of others, or a combination of various products of third parties, and a combination of various products chosen by the user or others. It is the responsibility of the users of these products, products of third parties, and a combination of various products, to exercise caution and familiarize themselves with all applicable laws, government regulations and safety requirements.

Nor are representations made or intended as to the useful life, maintenance cycles, efficiency or performance of the referenced products or any combination of products.

This material must not be used for estimating purpose. Production rates, labor performance or surface finishes are the sole responsibility of the user based on the user's expertise, experience and knowledge of industry variables.

It is the responsibility of the user to insure that proper and comprehensive training of operators has been performed and all environmental and safety precautions observed.

**ALLSOURCE** provides a variety of excellent products to the surface preparation industry, and we are confident that all proficient users, operators and contractors in this industry will continue to use our products in a safe and knowledge manner.

Before using this product, read all instructions, literature, labels, specifications and warnings sent with and affixed to the unit. If operation of the unit is unclear after reading this manual, contact your supervisor for instructions. It is the responsibility of the employer to read the following instructions to users of this equipment, who are unable to read. Periodic inspection at the work site should be made by supervisory personnel to ensure the blast machine is being properly used and maintained. A copy of this owner's manual must be kept with the blast machine and readily accessible to the blast machine operators at all times.

# ASSEMBLY INSTRUCTIONS

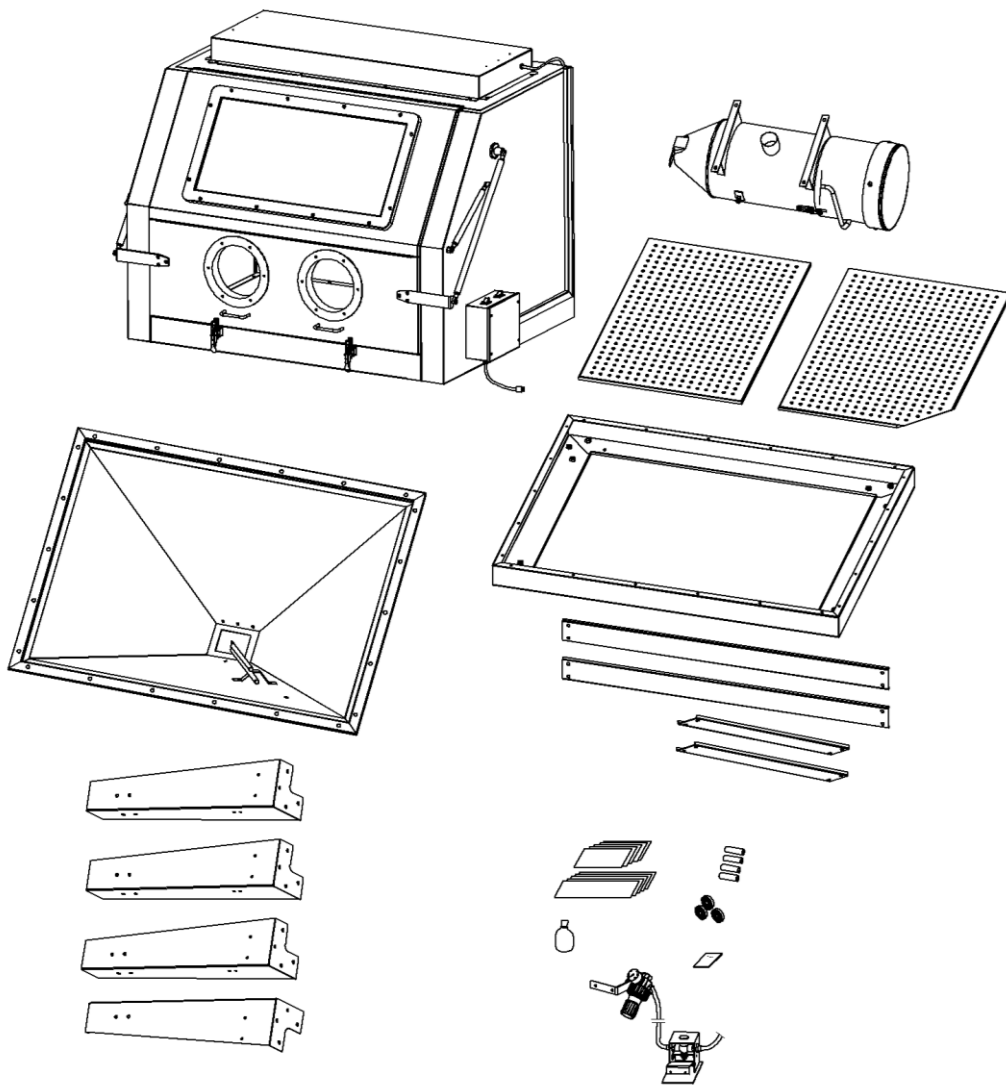

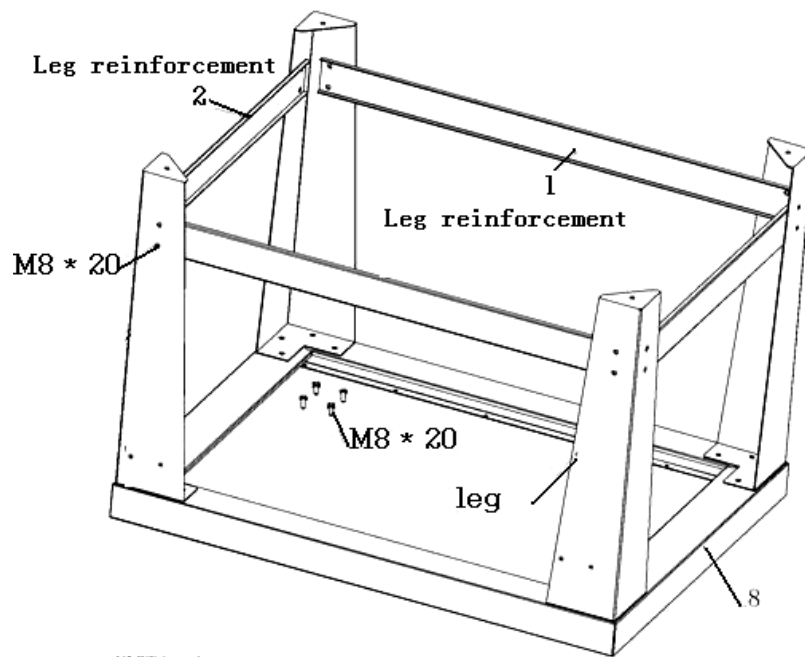

**STEP <1>**

1. Lay bracket face down (#8), use M8\*20 hex bolt (match faced washers, spring washers, to install 4 legs.
2. Use M8\*20 hex bolt and faced washers, spring washers to install leg and reinforcement brackets to legs.

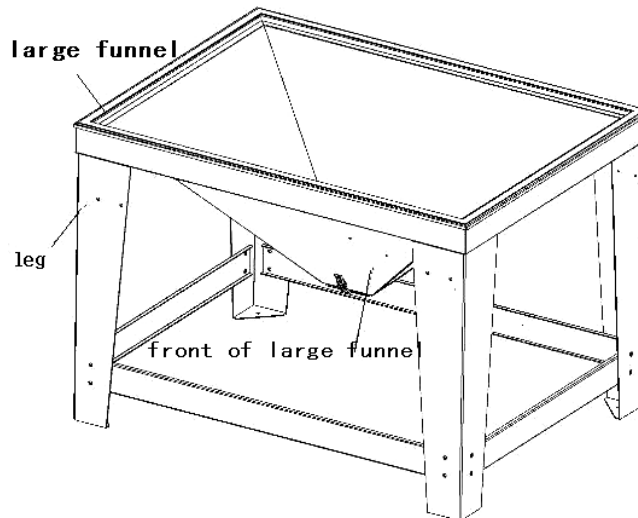

**STEP<2>:**

Please place assembled parts of Step <1> to position as shown in figure, then place the large funnel in the middle.

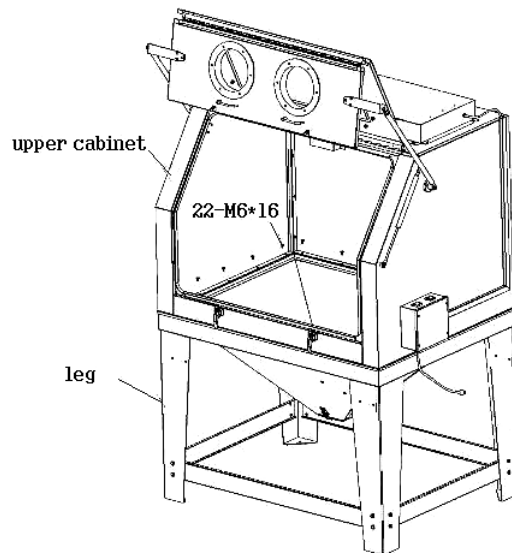

**Step<3>:**

1. Place the upper cabinet on the assembly Step<2> as shown in figure.
2. Opening the double folded door, assemble the upper cabinet, large funnel & bracket using 22pcs M6\*16 round head screws and faced washers.

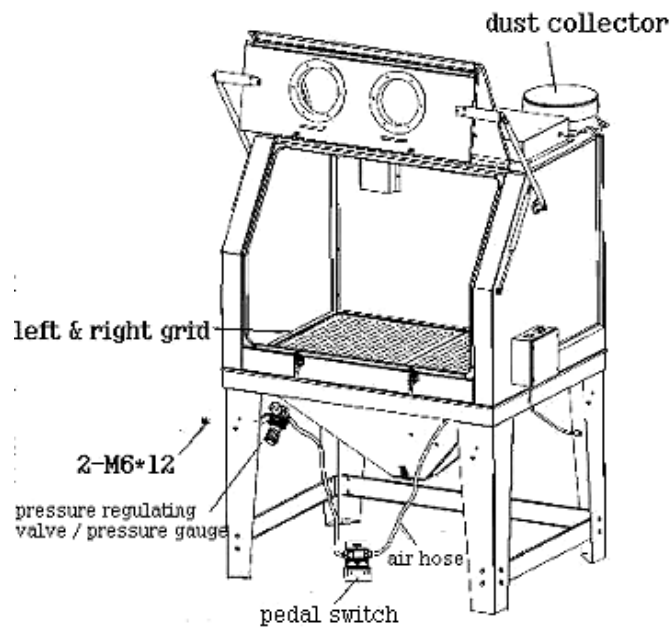

**Step<4>:**

1. Taking 4pcs M6\*12 large head screws, & M6 flange nuts to mount the dust collector to the back panel. Plug in assembled dust collector plug into the socket of switch box through the channel on the right side of cabinet.
2. Mount pressure regulating valve left front leg. Connect the orange air hose of foot valve, then connect it to the blast gun.
3. Place the left / right grid in the upper cabinet.
4. Move the abrasive blast cabinet to the final position by forklift, then remove the front reinforcement bracket.

## OPERATING INSTRUCTIONS

### 1. PREPARING PARTS FOR BLASTING

All parts processed must be free of oil, grease and moisture. Make sure parts are dry before putting into the cabinet for cleaning.

### 2. AIR PRESSURE

Operating pressure: **from 80 to 110 PSI (pounds per square inch) higher pressure, up to 110 PSI can be used, but this breaks down some types of media prematurely.**

- Set air pressure to 80 PSI. Most parts for blast cleaning can be blasted at 80 PSI, for light gauge steel, aluminum, and other more delicate parts, start at lower pressure and gradually increase the pressure until the desired finish is achieved.

#### **WARNING:**

Do not connect to high pressure bottle gas; rupture and explosion can occur.

### 3. GUN ANGLE AND DISTANCE

Direct the blast gun at parts at 45-60 degree angle with ricochet towards the back of the cabinet. Do not hold gun at 90 degree angle to parts being processed. This will cause the media blast to bounce back into the blast stream and slow blasting action. Also 90 degree angle will cause excessive wear on gun and viewing window. Hold gun approximately 6 inches from parts being blasted.

#### **WARNING:**

Gun must always be pointed away from the operator and towards items being processed. Never blast with any of the cabinet doors open, while loading and unloading. No one should be at the operator station, at the front of the blast cabinet.

### 4. MEDIA

- Media should be of good quality and dry. Moisture will cause the media to not flow and will clog metering valve and hopper.

### 5. NOZZLE SIZE

- By changing to the next larger size of nozzle, production can increase significantly. Larger size nozzles produce a large cleaning pattern. This, however, requires more air (your compressor must be able to provide this)

## MAINTENANCE INSTRUCTIONS

### 1. BLASTING GUN

- After 10-12 hours of blasting time, the nozzle should be checked. If it shows uneven wear it should be turned 1/4 turn every 10 hours of use.

### 2. CAKING OF MEDIA

- Media caking is caused by moisture in the air supply from oily and greasy parts. If this is not corrected media will not flow evenly and will plug up in the metering valve and the gun. Check air supply; if water is present install a good moisture trap. If oily or greasy parts are being blasted, you should degrease and dry the parts first.

### **3. REVERSE PRESSURE**

- If media stops flowing occasionally, place cover over nozzle (hold tight) and push foot pedal down for a couple of seconds. This will cause the system to back blast through the gun and up the media hose. This will help loosen any clogs.

### **4. GUN AIR PRESSURE DROP**

- Set the air pressure to 80 PSI on the air gauge at regulator. Push the foot pedal while holding gun and see if the gauge pressure drops significantly. If the pressure drops, this indicates that there is a restriction in the supply line. This could be that hose is too small, a reducer of quick coupler, a plugged filter, or other piping that doesn't allow enough air through. Also if the cabinet is too far from the air compressor, a pressure drop will occur. Air supply line should be ½" or larger.

### **5. POOR VISIBILITY-EXCESSIVE DUST**

- Air inlet at front left above regulator, should be free to allow air into cabinet.
- Dust container full and needs to be cleaned and emptied. (latch at bottom of dust collector)  
Dust cartridge contaminated. (clean or replace filter in dust collector, part#19)
- Media breakdown; eventually the media becomes so small that it is essentially dust. Replace media and clean dust collector.

### **6. POOR VISIBILITY-VIEWING WINDOW**

- Viewing windows come with a clear plastic protector on them. As these become pitted they can be easily replaced to extend the life of the window. The window can also be easily replaced

### **7. POOR MEDIA FLOW**

- Check for moisture as indicated above. Install moisture trap as needed, replace damp media and clean hoses and pump.
- Holes in media hose will cause poor media delivery. Replace hose.
- Debris in media. Replace or screen media.

## **MAINTAIN SUCTION EFFICIENCY WITH SIMPLE STEPS**

The most common problem customers have with their suction (venture) blast cabinets is a decrease in production rates. A properly maintained suction cabinet should provide years of constant service. When production rates fall the operator can usually locate the problem by checking

### **1. AIR SUPPLY**

- If the pressure gauge on the regulator shows an adequate no-load supply (when the blaster is not running), press the foot pedal. If the pressure drops more than a few PSI your air supply is restricted or inadequate. Clean filters and moisture separators all the way back to the air compressor. Straighten any kinky lines. Use a master gauge to check the air pressure or replace existing gauge if you suspect it is giving you false readings.

### **2. BLAST GUN**

- The nozzle will wear out eventually. Replace it if it's measured 1/16" over its original size or if it shows uneven wear. Adjust as needed for different media and conditions. A properly working

gun will pull 13-17 inches of vacuum.

### **3. DUST COLLECTOR**

- Inadequate cabinet ventilation results in reduced cleaning power at the nozzle as well as diminished view of the work in progress. Use the dust collector, shake every 20-30 minutes when the cabinet is turned off, (more often in dusty conditions.) Empty dust collector at least once a day. Remove filter and blow out occasionally to keep the dust collector or vacuum working efficiently. Replace as needed.

### **4. MEDIA**

- Use quality blast media sized to the job. Damp to dirty media can bring blasting to an instant halt. Store media in a dry area and load the appropriate quantity. Add enough media through the flooring to have 6" deep of media on top of the metering valve. If you run out of media as you are blasting add enough so it keeps circulating to the gun. The media will eventually breakdown or get too contaminated to use. The less there is in the system, the less you will have to replace.

### **5. MEDIA DELIVERY**

- Replace any media hose that has soft spots or visible wear. Adjust the metering valve to provide adequate flow. A mixture that is too rich will cause pulsating at the gun. An unusually loud noise while blasting means the mixture is too lean. A rich mixture can result in lower impact velocities. While a lean mixture reduces the number of impacts. Both reduce your cleaning rate.

If everything is adjusted right and you are still not getting the production levels needed, contact your distributor.

## **RECOMMENDATIONS**

### **AIR COMPRESSOR RECOMMENDATION:**

To permit efficient operation of your air compressor, follow these guidelines:

1. Use a smaller size nozzle to control the demand of air.
2. Do not blast continuously. Stop blasting operation periodically to allow the compressor to cool. No compressor is designed to constantly run at full RPM. Use 70% of the rated output.
3. Use a minimum ½" air hose or metal piping from your air compressor to the blaster. If your compressor is creating an excessive amount of moisture, we recommend using a water trap or a moisture separator.
4. The air compressor should be drained at the bottom of the supply tank through a drain valve and should be blown down daily. It is not unusual to drain three or four gallons of water from the supply tank on a high humidity day. An additional supply tank will help.
5. Keep dust and media created by blasting away from the air compressor unit. Observe maximum air pressure requirements for the blaster and either set your compressor to run within these limits or use a pressure regulator valve to reduce the air pressure to the appropriate range.

### **ABRASIVE (MEDIA) USAGE:**

1. If moisture is in the media it will eventually damage the blaster or plug the system. Keep the media and compressor air dry to avoid this problem.
2. If media is moist, screen it and dry it before using.
3. Store media in a dry place; keep media off the ground or concrete floors. Put it on a wooden skid.
4. If the humidity is excessively high, it may not be advisable to blast at that time.
5. Consider using different grades or different types of media to prevent nozzle clogging due to high moisture content.
6. Do not use sand.

## AIR REQUIREMENTS

### SUPPLY AIR PIPE SIZE in inches

Line (cfm)	Volume of air through pipe									
	25	30	35	40	50	60	70	80	100	125
Length	25	30	35	40	50	60	70	80	100	125
25'	.75	.75	.75	.75	1	1	1	1.25	1.25	1.25
50'	.75	.75	.75	1	1	1	1	1.25	1.25	1.25
75'	.75	.75	1	1	1	1	1	1.25	1.25	1.25
100'	.75	.75	1	1	1	1	1.25	1.25	1.25	1.25
150'	.75	1	1	1	1	1.25	1.25	1.5	1.5	1.5
200'	1	1	1	1	1	1.25	1.25	1.5	1.5	1.5
250'	1	1	1	1	1	1.25	1.25	1.5	1.5	1.5
300'	1	1	1	1	1	1.25	1.25	1.5	1.5	1.5

# MEDIA

## Steel Grit

Steel Grit is extremely fast cutting on rusty metal and hard to remove paint. Steel Grit is popular because it leaves a very smooth finish. It is also comparable in price to most other specialty abrasives. Steel Grit is recommended in reclaim systems or cabinets. (25 lbs. container)

## Glass Bead

Glass Bead is used in creating a satin or matte finish. Glass Bead is recommended in reclaim systems or cabinets. (25 lbs. container)

## Aluminum Oxide

Aluminum Oxide is a high quality abrasive that is sharper than sand (not recommended) and cuts twice as fast as sand. It leaves a smooth textured finish with no pits or burrs. Aluminum Oxide is rougher than glass bead and can be used over and over again. It is one of the most economical abrasives you can use in any reclaim systems or cabinets. (25 lbs. container)

## Plastic Grit

Plastic Grit is primarily used to strip aluminum and fiberglass. It is great for stripping paint, light oxidation and surface rust. Plastic Grit is recommended for use in blast cabinets because it creates very little dust. Works quickly, lasts a long time and increases visibility within the cabinet. (10 lbs container)

## Walnut Shells

Walnut Shells are recommended for use on "soft" surfaces such as aluminum, glass, wood, and other areas where no pitting is desired. Walnut Shells leaves a smooth, dull finish. (10 lbs container)

## Corn Cob

Corn Cob abrasive is used on soft applications such as wooden surfaces, aluminum, brass and other surfaces where no pitting is desired. Corn Cob leaves a smooth, dull finish. (50 lbs container)

# PARTS DIAGRAM-1

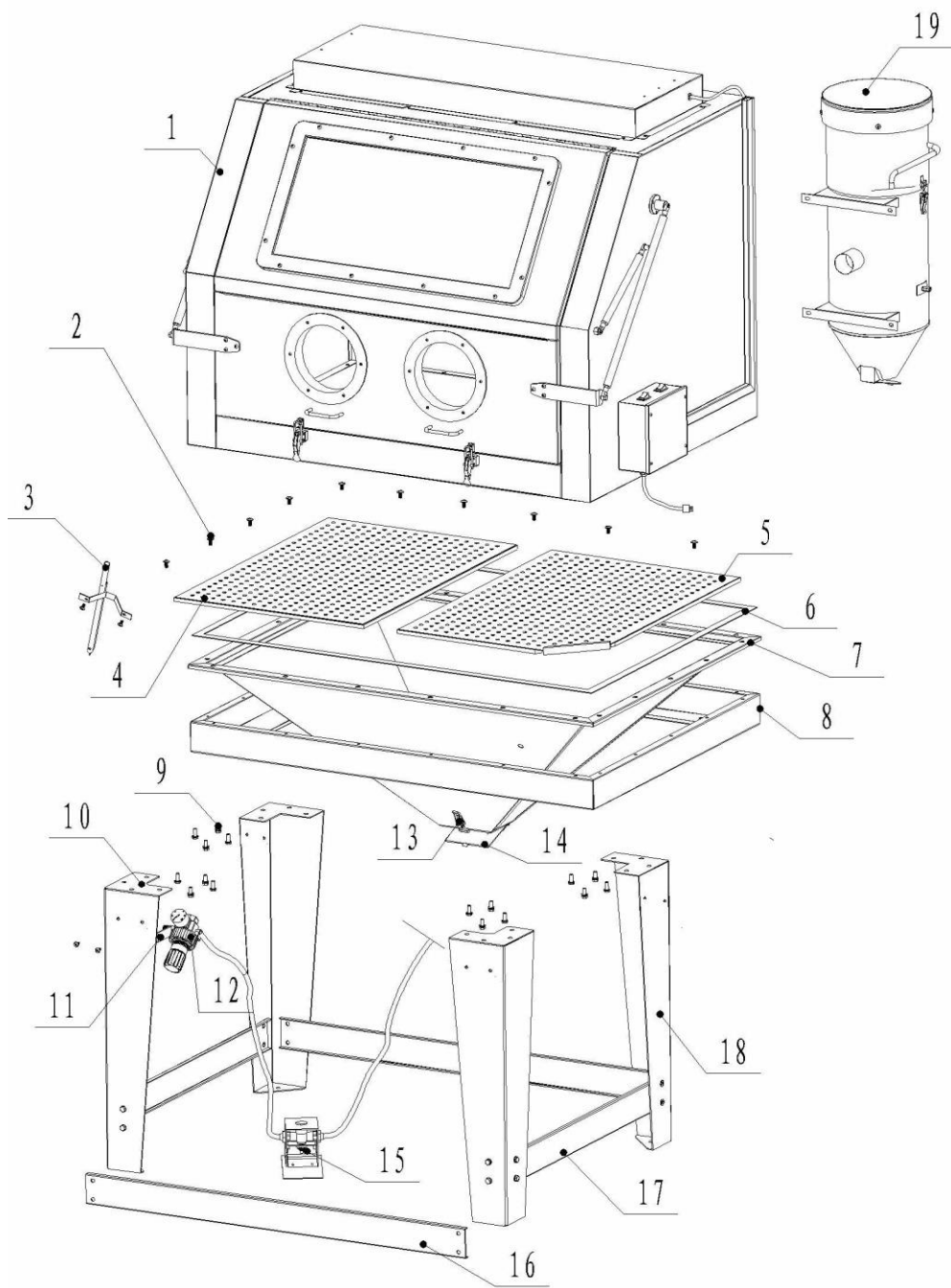

## PARTS DIAGRAM-2

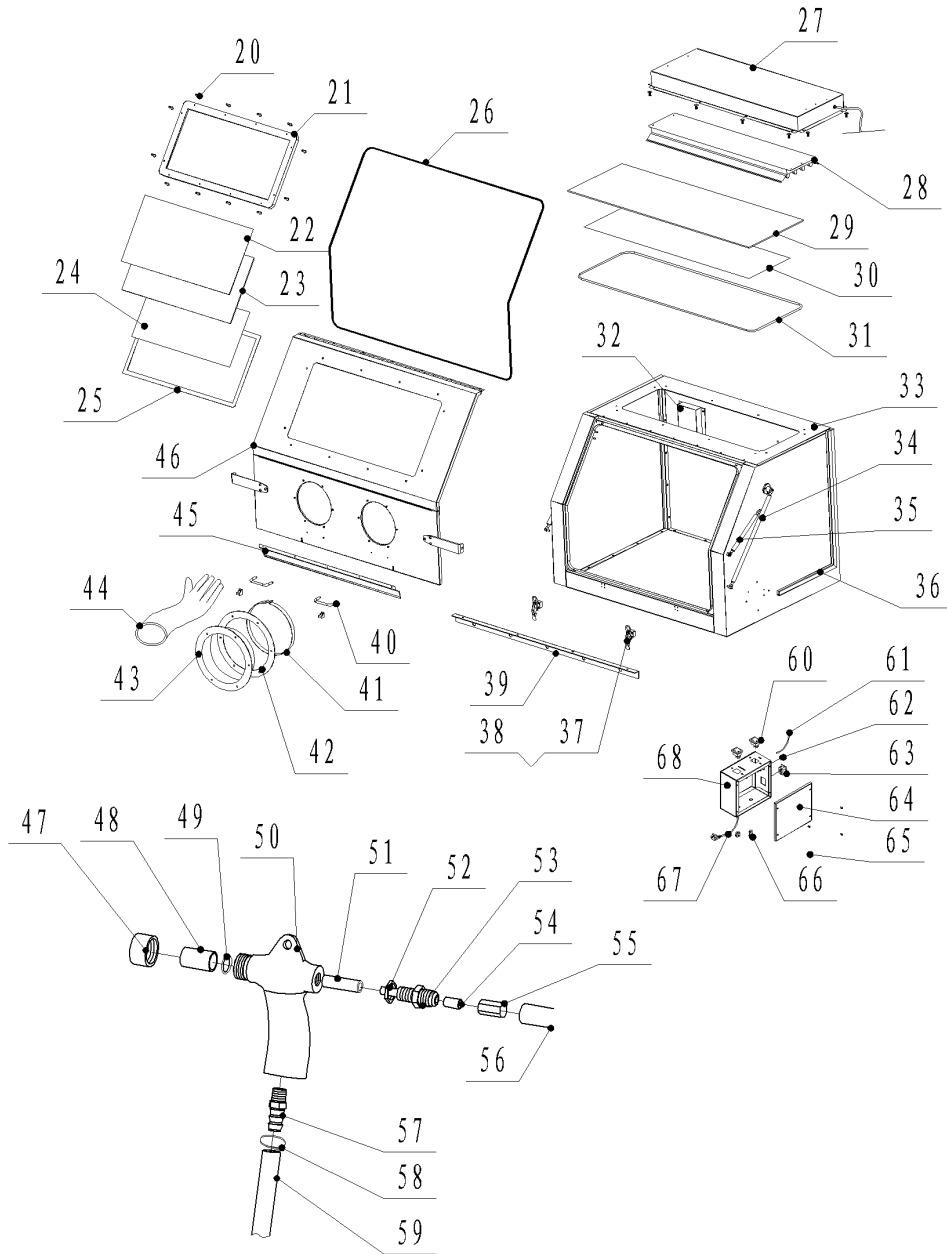

### WIRING DIAGRAM

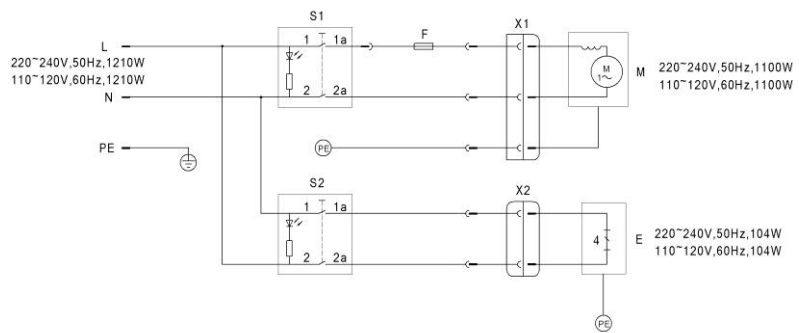

L PHASE WIRE  
 N NEUTRAL WIRE  
 PE GROUND WIRE  
 F FUSE  
 E LIGHT WITH FOUR  
 FLUORESCENT TUBES

X1 CONNECTOR  
 X2 CONNECTOR  
 S1 LIGHT SWITCH  
 S2 MOTOR SWITCH  
 M MOTOR

## PARTS LISTING

ITEM#	DESCRIPTION	QUANTITY
1	Upper cabinet	1
2	Round head cross screws (matched washers)	22
3	Suction abrasive hose	1
4	Left grid – 41804	1
5	Right grid – 41805	1
6	Sealing tape – PSA foam	1
7	Large funnel	1
8	Bracket	1
9	M8*20	32
10	Leg B	1
11	Mounting bracket	1
12	Air regulator with pressure gauge - 4150009	Each 1
13	Assembled latches – 41813	3
14	Welded reflector for falling abrasive - 41814	1
15	Foot pedal – 4150011 (does not include connection fittings)	1
16	Leg reinforcement 1 - 41816	2
17	Leg reinforcement 2 - 41817	2
18	Legs - 41818	3
19	Dust collector - 4150063	1
20	M6*32 round head screws	12
21	Frame for viewing window - 41821	1
22	Outer viewing window - 41822	1
23	Inner viewing window, plexiglass - 41823	1
24	PE film of viewing window - 41824	1
25	Sealing tape of viewing window - 10793 (sold per foot)	1
26	Rubber seal strip of front opening doorframe - 41826	1
27	Bracket of top light - 41827	1
28	Fluorescent fixture, 1 amp 4 bulbs - 41828	1
29	Light window - 41829	1
30	PE film of light window - 41830	1
31	Molded rubber seal strip of light window - 41831	1
32	Cover	2
33	Main body of upper cabinet	1
34	Main support poles - 41834	2
35	Support for main pole - 41835	2
36	Plastic conduit for wire	1
37	Front door latch - 41837	2

38	Latch seats - 41838	2
39	Rack board	1
40	Grips - 41840	2
41	Elements of glove rings	2
42	Mounting ring of gloves – 4150020 (includes #43)	2
43	Glove ring gasket	2
44	Gloves - 4150015	1 pair
45	Front operation reflector	1
46	Elements of front opening door	1
47	Nozzle holding nut - 4150042	1
48	Nozzle – 4150046 (6mm) 4150047 (7mm)	1
49	Nozzle O-ring - 4150048	1
50	Gun body – 4150049 (includes 47, 51, 52 & 53)	1
51	Sleeve of air jet - 4150051	1
52	Lock nut - 4150050	1
53	Air jet with sleeve & nut - 4150052	1
54	12-G1/4" quick straight-pass connector - 41854	1
55	Conversion connector - 41855	1
56	Air hose $\phi$ 12x $\phi$ 8, 51" long orange - 41856	1
57	Quick fitting G3/8" - 4150054	1
58	Hose Clamp - 4150057	2
59	1/2" abrasive hose – 60" long - 41859	1
60	Switches - 4150041	2
61	Power cord	1
62	wire clips	2
63	Socket	1
64	Cover of E-box	1
65	Self tapping screws	4
66	Fuse holder - 41866	1
67	Power cord	1
68	Body of E-box – 41868	1

Dust Collector filter = 4150029

Dust Collector motor = 40287

**Disclaimer of Warranties:** Manufacturer, distributor, and **ALLSOURCE** (“**ALLSOURCE**”) makes no warranties with respect to any goods delivered to Buyer or users except as specifically set forth within this manual. **ALLSOURCE** MAKES NO IMPLIED WARRANTIES OF MERCHANTABILITY OR FITNESS FOR A PARTICULAR PURPOSE WITH RESPECT TO ANY OF THE GOODS, AND Seller EXPRESSLY DISCLAIMS ANY IMPLIED WARRANTIES AGAINST INFRINGEMENT. **ALLSOURCE** WARRANTIES SHALL NOT APPLY TO ANY DAMAGE OR NON-CONFORMITY RESULTING FROM THE NEGLIGENCE OF IMPROPER ASSEMBLY OR USE OF ANY GOODS BY USERS OR BUYER OR ITS EMPLOYEES OR AGENTS, OR FROM ALTERATION OR ATTEMPTED REPAIR BY ANY PERSON OTHER THAN MANUFACTURER. ALL USED, REPAIRED, MODIFIED OR ALTERED ITEMS ARE PURCHASED AS-IS AND WITH ALL FAULTS.

### **LIMITED WARRANTY**

**ALLSOURCE** warrants this product to be free from defects in materials or workmanship for one year after the date of original purchase. This warranty does not include damage resulting from accident, abuse or misuse of the product. Nor does it apply to parts subject to abrasive wear, i.e., nozzles, valves, hose connections and hoses. Implied warranties including those of merchantability and fitness for a particular purpose are excluded to the extent permitted by law, and any and all implied warranties are excluded. Reimbursement of original purchase price is the exclusive remedy and liability for consequential damages under any and all warranties which are also excluded to the extent exclusion is permitted by law.

Contact us at 1-800-253-9726 or [sales@shindustries.com](mailto:sales@shindustries.com)

You can learn more about us at [www.shindustries.com](http://www.shindustries.com)

S&H Industries Inc.  
5200 Richmond Road  
Cleveland, Ohio 44146