

5GALLON

ABRASIVE BLASTER

OPERATING AND MAINTENANCE INSTRUCTIONS

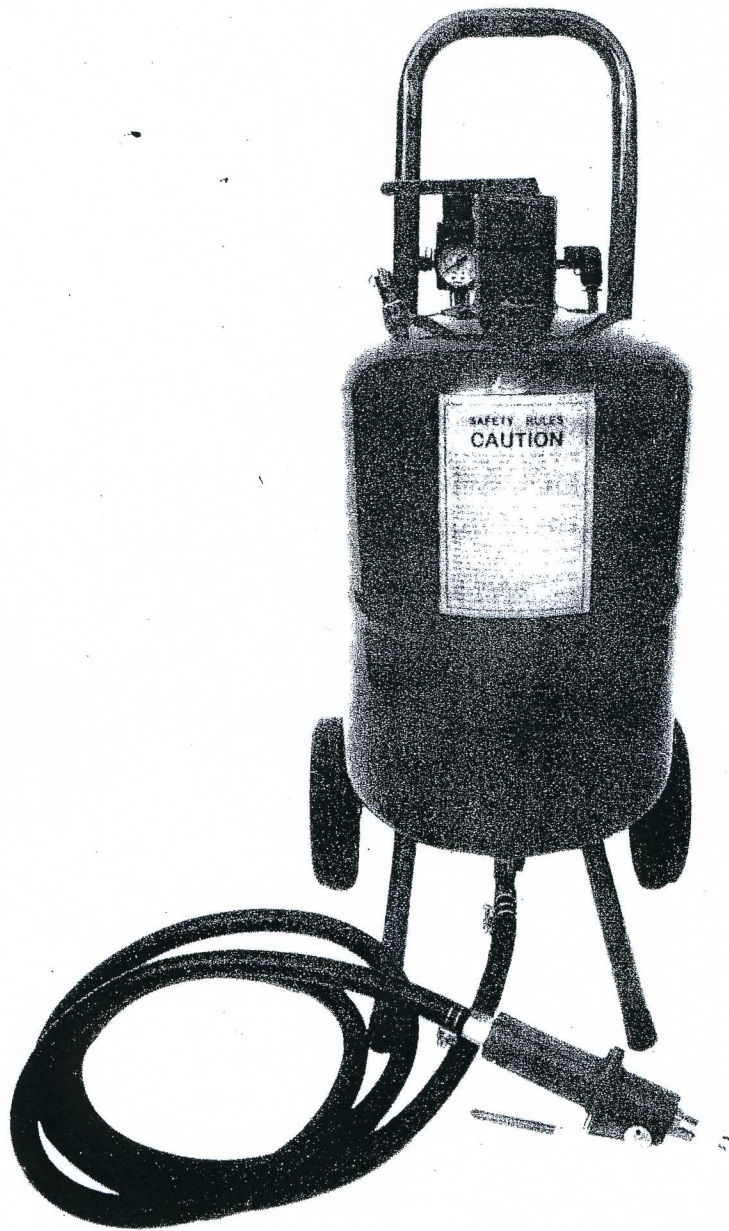

SPECIFICATIONS

Tank Volume	5gallon
Hose Length:	10 feet
Working Pressure	60-110 PSI
Air Consumption:	6-25cfm
Overall Dimensions:	13-3/8"X15-3/4"X30-25/32"
Weight:	27 lbs

SAVE THIS MANUAL

You will need this manual for the safety warnings and cautions, assembly instructions, operating procedures, maintenance procedures, troubleshooting, parts list and diagram. Keep it in a safe, dry place for future reference.

SAFETY WARNING & CAUTIONS

WARNING: When using pneumatic equipment, basic safety precautions should always be followed to reduce the risk of personal injury and hazards due to over pressurization.

READ ALL INSTRUCTIONS BEFORE USING THIS TOOL!

1. **KEEP WORK AREA CLEAN.** Cluttered areas invite injuries.
2. **OBSERVE WORK AREA CONDITIONS.** Do not use tools in damp, wet, or poorly lit locations. Don't expose to rain. Keep work area, well lit. Do not use abrasive blasters in the presence of flammable gases or liquids because an explosion may result. User should not use tools or equipment improperly or tools or equipment that has been abused or badly worn as damage or injury may result.
3. **KEEP CHILDREN AWAY.** Children must never be allowed in the work area. Do not let them handle machines, tools, or hoses.
4. **STORE IDLE EQUIPMENT.** When not in use, tools must be locked

- up in a dry location to inhibit rust. Always lock up tools and keep out of reach of children.
5. **DO NOT FORCE THE TOOL.** It will do the job better and more safely at the rate for which it was intended. Do not use inappropriate attachments in an attempt to exceed the tool's capacities.
 6. **USE THE RIGHT TOOL FOR THE JOB.** Do not attempt to force a small tool or attachment to do the work of a larger industrial tool. Do not use a tool for a purpose for which it was not intended.
 7. **DRESS PROPERLY.** Do not wear loose clothing or jewelry as they can be caught in moving parts. Non-skid footwear is recommended. Wear restrictive hair covering to contain long hair. Always wear the hood (included), an MAHA/NCOSH approved respirator, and heavy-duty gloves.
 8. **USE EYE AND EAR PROTECTION.** Wear full hood when operating an abrasive blaster, a MSHA/NCOSH approved dust mask or respirator when working around metal, wood, and chemical dusts and mists.
 9. **DO NOT OVERREACH.** Keep proper footing and balance at all times. Do not reach over or across running machines.
 10. **MAINTAIN TOOLS WITH CARE.** Follow instructions for changing accessories. Inspect all hoses for leaks prior to use. The handles must be kept clean, dry, and free from oil and grease at all times.
 11. **AVOID UNINTENTIONAL STARTING.** Make sure the air pressure adjuster be set at "Zero" and the shut off valve is in the off position when not in use, and before attaching the air compressor.
 12. **STAY ALERT.** Watch what you are doing, use common sense. Do not operate any tool when you are tired.
 13. **CHECK DAMAGED PARTS.** Before using any tool, any part that appears damaged should be carefully checked to determine that it will operate properly and perform its intended function. Check for

alignment and binding of moving parts; any broken parts or mounting fixtures; and any other condition that may affect proper operation. Any part that is damaged should be properly repaired or replaced by a qualified technician.

14. **REPLACEMENT PARTS AND ACCESSORIES.** When servicing, use only identical replacement parts. Use of any other parts will void the warranty. Only use parts and accessories intended for use with this tool.
15. **DO NOT OPERATE TOOL IF UNDER THE INFLUENCE OF ALCOHOL OR DRUGS.** Read warning labels on prescriptions to determine if your judgment or reflexes are impaired while taking drugs. If there is any doubt, do not operate the tool.
16. **DRAIN WATER TRAPPED IN THE AIR PRESSURE ADJUSTER PERIODICALLY.**
17. **DO NOT ALLOW ABRASIVE BLASTER TO SIT PRESSURIZED WHILE UNATTENDED OR NOT IN USE.**
18. **MAKE SURE ALL EQUIPMENT IS RATED TO THE APPROPRIATE CAPACITY.** Make sure that regulator is set at no higher than 110 PSI.
19. **PERIODICALLY CHECK THE ABRASIVE DELIVERY EQUIPMENT,** Valves, hoses and nozzles that carry the abrasive after it leaves the pressure tank are subjected to the abrasive blasting action so will wear out more quickly than other components.
20. **RELEASE THE AIR PRESSURE OF THE TANK BEFORE OPENING.** Open the shut off valve to release pressure. Make sure pressure gauge reads "0" . Remove compressor air hose from tank.
21. **MAINTAIN CORRECT AIR PRESSURE WHENEVER WORKING.** Do not allow pressure to excess 110 PSI. If the safety valve does not release excess air pressure at 125 PSI, stop all work and open the shut off valve to release pressure in the tank.

22. WARNING: READ BEFORE PURCHASE OR USE OF PRODUCT. THE USE OF SILICA SAND OR ANY SILICA-BASED PRODUCT IS NOT RECOMMENDED IN ANY ABRASIVE BLASTER. USE OF SUCH MATERIALS COULD BE SERIOUSLY HARMFUL TO YOUR HEALTH. SUCH MATERIALS HAVE BEEN KNOWN TO CAUSE CANCER OR OTHER DEADLY DISEASES. READ CAREFULLY THE MSDS (MATERIAL SAFETY DATA SHEET) FOR ANY ABRASIVE USED WITH THIS PRODUCT. CONSULT MSHA/NCOSH OR OTHER SAFETY SOURCES FOR THE PROPER TYPE OF RESPIRATORY EQUIPMENT.

AIR/ABRASIVE SUPPLY REQUIREMENTS

Hose ID	Hose Length	Nozzle ID	CFM@ 110 PSI	Abrasive Use Per Hour
3/8"	50ft.	0.076"	6	30 Lbs
3/8"	25ft.	0.098"	12	80 Lbs
1/2"	50ft.	0.118"	20	120 Lbs
1/2"	15ft.	0.132"	25	150 Lbs

UNPACKING

When unpacking, sort all pieces and check according to the parts list and diagram on page 15 and 16 to make sure all parts are included.

WARNING

The Warning, cautions, and instructions discussed in this instruction manual cannot cover all possible conditions and situations that may occur.

It must be understood by the operator that common sense and caution are factors which cannot be built into this product, but must be supplied by the operator.

ASSEMBLY

NOTE: Use Teflon Pipe Tape on all threaded joints. Make sure all joints are securely tightened.

Legs, Wheels and Handle Bar Assembly (Refer to Figure 1)

Step 1: Get out the two WHEELS (#14), the six COTTER PINS, the two LEGS (#7), the AXLE (#29), the four SCREWS & NUTS (#2), and the tow SELF-TAPPING SCREWS(#31).

Step 2: Attach both the LEFT LEG and the RIGHT LEG to the TANK (# 5) using the four SCREWS & NUTS. The bottom section of the two legs must point outward respectively, and the holes in the bottom of the legs must be parallel to each other.

Step 3: Attach one of the WHEELS to the AXLE using one of the COTTER PINS.

Step 4: Slide the AXLE through the holes in the bottom of the two legs, using four COTTER PINS to fix the position of the AXLE.

Step 5: Attach the other WHEEL to the AXLE using the remaining COTTER PIN.

Step 6: Slide the HANDLE BAR onto the left LEFT LEG and the RIGHT LEG, and secure it using two SELF-TAPPING SCREWS.

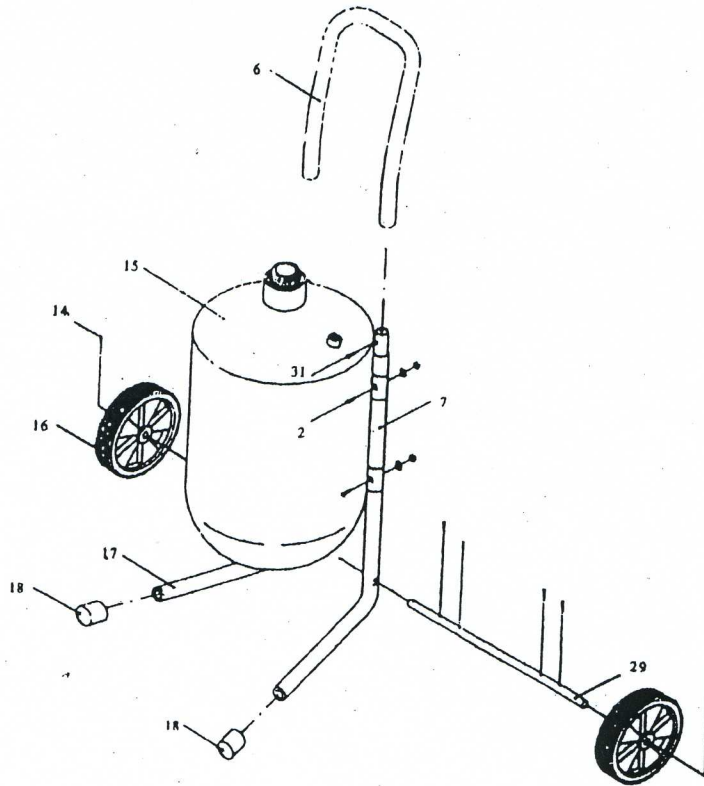

FIGURE 1

Abrasive Metering Valve and Nozzle DEADMAN Valve Assembly (Refer to Figure 2)

- Step 1: Get out all required parts as shown in the Figure 2.
- Step 2: Attach the ABRAISVE METERING VALVE (#30) to the side hole of the INTAKE MANIFOLD (#12); Attach one of the ELBOW CONNECTORS (#13) and one of the HOSE ADAPTOR (#23) to either remaining hole of the INTAKE MANIFOLD (#12).
- Step 3: Attach the other side of the ABRASIVE METERING VALVE (#30) to the bottom of the TANK.
- Step 4: Attach the other HOSE ADAPTOR (#23) to the DEADMAN VALVE CONNECTOR (#33); attach the NIPPLE CONNECTOR

- (#25) to the other end of the DEADMAN VALVE CONNECTOR(#33)
- Step 5: Put the narrow end of the NOZZLE (#27) through the NOZZLE CAP NUT (#28).
- Step 6: Attach the NOZZLE CAP NUT (#28) to the remaining end of the NIPPLE CONNECTOR (#32), with the GASKET (#26) between the NIPPLE CONNECTOR (#25) and the NOZZLE (#27).
- Step 7: Slide the HOSE CLAMPS (#22) over either side of the ABRASIVE HOSE (#21). DO not tighten yet.
- Step 8: Slide the two ends of the ABRASIVE HOSE (#21) onto the two HOSE ADAPTORS (#23) respectively. Tighten the HOSE CLAMPS (#22) very securely.

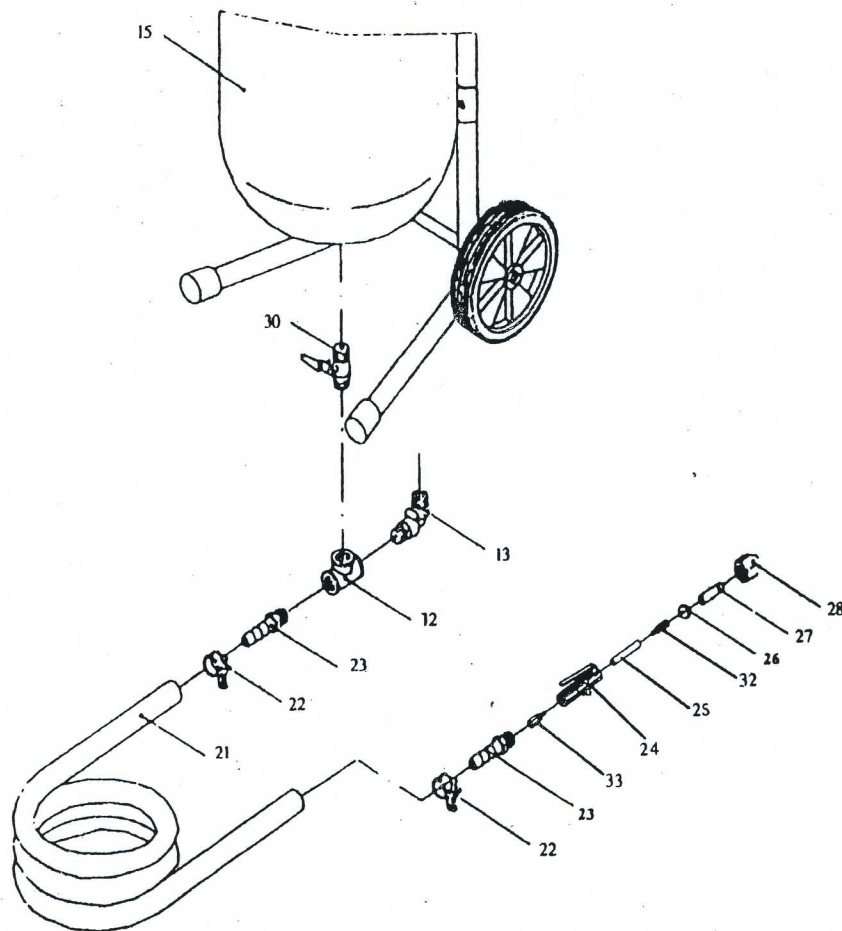

FIGURE 2

Air Pressure Adjuster and Safety Valve Assembly (Refer to Figure 3)

Step 1: Get out all required parts as shown in Figure 3.

Step 2: Attach the CONNECTOR (#8) to one of the side holes of the AIR PRESSURE ADJUSTER (#9); Attach the NIPPLE CONNECTOR (#11) to the other side hold of the AIR PRESSURE ADJUSTOR (#9); attach the INTAKE MANIFOLD (#12) to the other side of the NIPPLE CONNECTOR (#11). Make sure the PRESSURE GAUGE on the AIR PRESSURE ADJUSTER (#9) and the side hole of the INTAKE MANIFOLD (#12) face the same direction.

Step 3: Attach the JOINT PIPE (#10) to the side hole of the INTAKE MANIFOLD (#12); Attach the other side of the JOINT PIPE (#10) to the corresponding opening on the top of the TANK.

Step 4: Attach the SAFETY VALVE (#15) onto the corresponding opening in the TANK.

Step 5: Screw the TANK FILLER CAP (#4) onto the filler opening with O-RING (#3) in between for sealing.

Step 6: Attach the ELBOW CONNECTOR (#13) to the remaining hole of the INTAKE MANIFOLD (#12). Make sure the other end of the ELBOW CONNECTOR (#13) point to the other ELBOW CONNECTOR in the bottom assembly.

Step 7: Attach the two ends of the AIR HOSE (#20) to the two ELBOW CONNECTORS (#13) in the top assembly and the bottom assembly respectively.

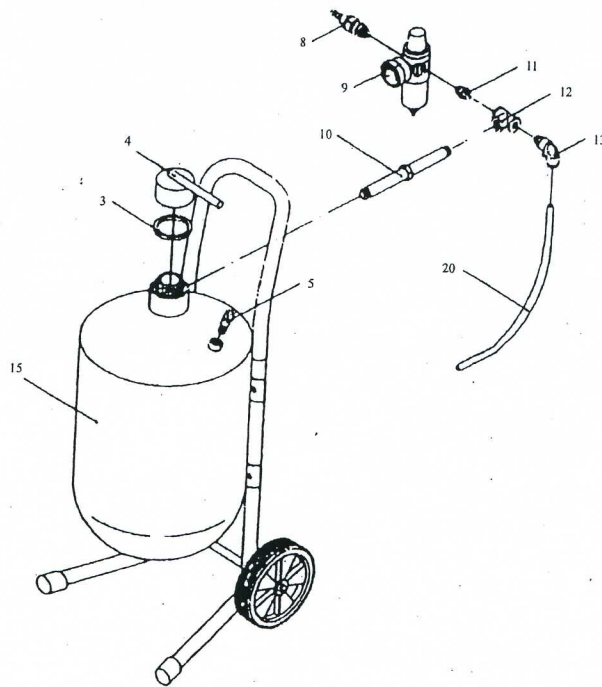

FIGURE 3

Operations:

WARNING: Always wear your hood and a MSHA/MCOSH approved respirator and heavy-duty gloves when operating the abrasive blaster.

Step 1: Close the ABRASIVE METERING VALVE (#30), pour into the TANK about 12KG abrasive medium. Then close the TANK FILLER CAP (#4) securely, assuring that O-RING (#3) is in place.

Step 2: Close the DEADMAN VALVE (#24), turn the AIR PRESSURE ADJUSTER (#9) counter-clockwise holding (pressure down) to the minimum setting; Attach the CONNECTOR (#8) to an air supply hose coming from an air compressor, tighten securely with a hose clamp.

Step 3: Switch on power to start up the air compressor, listen for leaks at the TANK FILLER CAP (#4) and along all hoses and fittings as pressurization begins. Repair any leaks before operating abrasive blaster.

Step 4: Turn the air pressure adjuster (#09) slowly clockwise till the pressure gauge reads a desired value (maximum 110LBS).

Step 5: Open the ABRASIVE METERING VALVE (#30) and push down to open the DEADMAN VALVE (#24) to an appropriate position to gain a desired abrasive flow. The amount of abrasive flow will vary depending on the type of abrasive, air pressure and the desired result. Do not open abrasive metering valve all the way, abrasive hose or nozzle clogging may result.

Step 6: After the work is finished, close the ABRASIVE METERING VALVE (#30) and turn the AIR PRESSURE ADJUSTER (#9) counter-clockwise till the pressure gauge reads "Zero", then push down to open the VALVE (#24) to let out the air pressure.

Step 7: If there is too much water trapped in the AIR PRESSURE ADJUSTER (#9), open the bottom valve to let out the water.

Maintenance

1. Keep your abrasive blaster clean, and protect from damage.
2. De-pressurize after each use.
3. When initially pressurizing, listen for leaks at the tank top and at all hoses and fittings. Repair any leaks before operating abrasive blaster. Leaking joints may be repaired by replacing worn or damaged Teflon tape at joints.
4. Check for worn abrasive hose and fittings. The abrasive metering valve, manifold, and all parts after the abrasive is ejected from the tank are subject to rapid wear, due to the flow of abrasive. Watch especially for leaks, blistering bulging or thinness of the hose. Replace any parts which appear worn.

Abrasive Selection

The kind of abrasive you choose will greatly influence the amount of time needed to clean a given surface area. Abrasive blasting materials include black beauty, steel grit, glass bead and aluminium oxide. Do not use sand or any silica based products. Assure that the abrasive you use is thoroughly dry. Damp abrasive can cause clogging of your abrasive blaster.

While you may reuse abrasive, remember that abrasive does wear out. After use, abrasive becomes smoother and rounder, thus reducing abrasive effectiveness.

Reusing abrasive may also cause clogging due to debris contained in the mixture from prior use.

WARNING: READ BEFORE PURCHASE OR USE OF PRODUCT .THE USE OF SILICA SAND OR ANY SILICA-BASED PRODUCT IS NOT RECOMMENDED IN ANY ABRASIVE BLASTER. USE OF SUCH MATERIALS COULD BE SERIOUSLY HARMFUL TO YOUR HEALTH. SUCH MATERIALS HAVE BEEN KNOWN TO CAUSE CANCER OR OTHER DEADLY DISEASES. READ CAREFULLY THE MSDS (MATERIAL SAFETY DATA SHEET) FOR ANY ABRASIVE USED WITH THIS PRODUCT. CONSULT MSHA/NIOSH OR OTHER SAFETY SOURCES FOR THE PROPER TYPE OF RESPIRATORY EQUIPMENT.

Abrasive Flow Adjustment

Choose a larger nozzle for a broader spray pattern; choose a smaller nozzle for more focused abrasive blasting.

Adjust air pressure with the AIR PRESSURE ADJUSTER (#9). Adjust abrasive flow with ABRASIVE METERING VALVE (#30). The amount of abrasive flow will vary depending on the type of abrasive, the amount of air pressure and the desired result. Do not open abrasive valve all the way, abrasive hose clogging may result.

Watch for abrasive clogging. De-pressurize if necessary and replace the abrasive with drier or cleaner abrasive.

Safety and Health Considerations

Before opening tank assure that it is not pressurized. Be sure that the gauge reads "0". De-pressurize the tank before opening by exhausting pressure through the DEADMAN VALVE (#24).

Disconnect the compressor before opening tank.

Protect yourself and those around you from "over spray". Remember that your portable abrasive blaster is shooting a powerful spray of abrasive material. Do not point it at yourself or anyone around you.

Wear protective clothing including Hood (#1), safety eye covering, MAHA/NCOSH approved respirators and heavy gloves when using this abrasive blaster.

You will create a cloud of abrasive material and debris, which is dangerous to inhale.

Remove, cover, or protect anything around you that might be damaged from direct or indirect contact with the abrasive spray or particles.

Nothing subject to contamination damage or with a fine surface should be near your abrasive blaster.

CAUTION

1. Pay particular attention to the ABRASIVE HOSE (#21), the DEADMAN VALVE (#24), and the NOZZLE (#27) as they will wear out much more quickly than the other pieces.
2. The ABRASIVE HOSE needs replacing when its sidewalls develop leaks or show blisters in the surface. Do not use if any of these problems are present.

Parts list

Part No.	Description	QTY	Part No.	Description	Qty
1	Hood	1	17	Right Leg	1
2	Screw	4	18	Leg End Cap	2
3	O-Ring	1	19	Funnel	1
4	Tank Filler Cap	1	20	Air Hose	1
5	Safety Valve	1	21	Abrasive Hose	1
6	Handle Bar	1	22	Hose Clamp	2
7	Left leg	1	23	Hose Adaptor	2
8	Connector	1	24	Deadman Valve	1
9	Air Pressure Adjuster	1	25	Rubber hose	1
10	Joint Pipe	1	26	Gasket	1
11	Nipple Connector	1	27	Nozzle	1
12	Intake Manifold	2	28	Nozzle Cap Nut	1
13	Elbow Connector	2	29	Axle	1
14	Cotter Pin	6	30	Abrasive Metering Valve	1
15	Tank	1	31	Self-tapping Screw	2
16	Wheel	2	32	Nipple connector	1
			33	Deadman valve adaptor	1

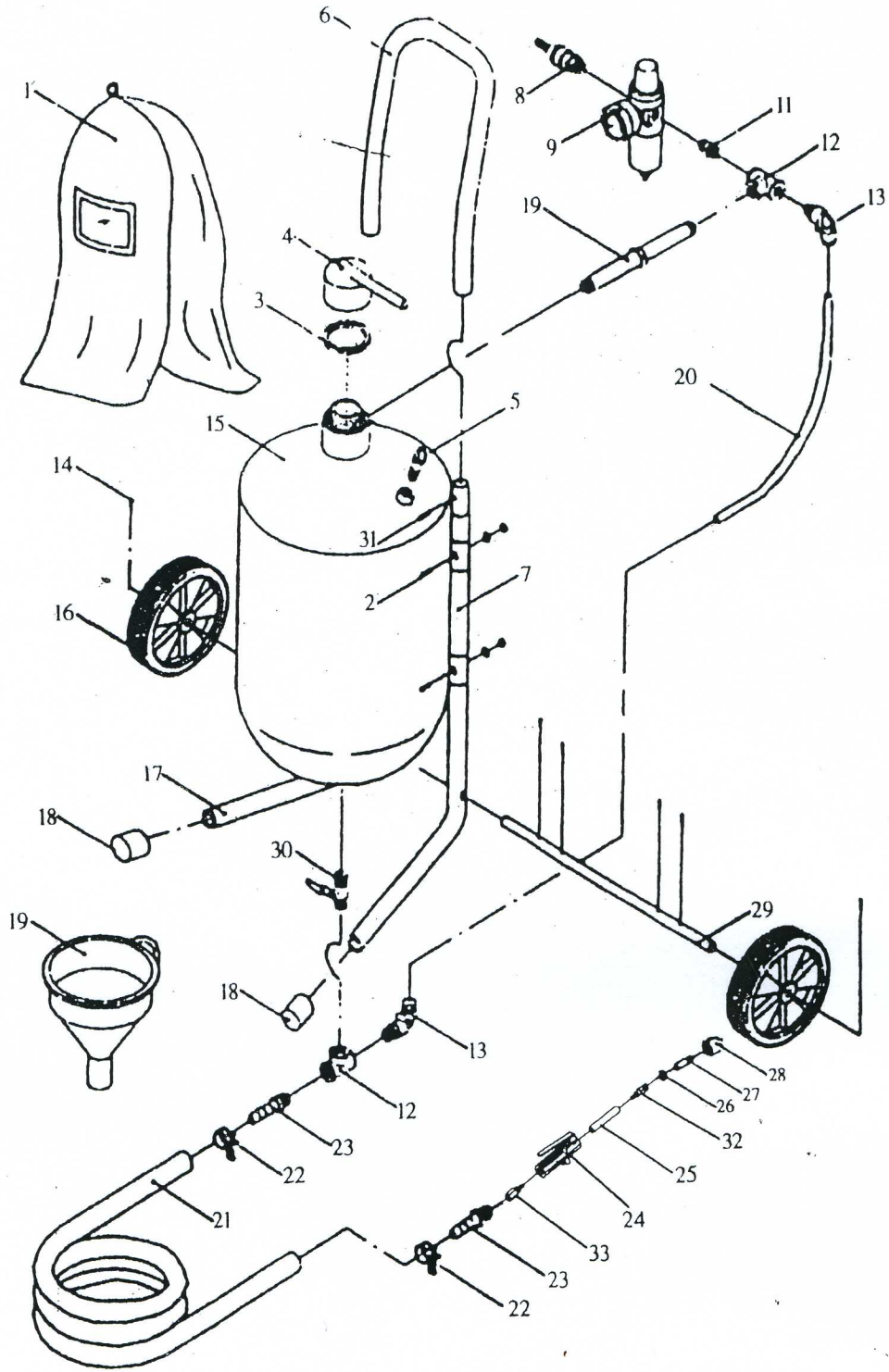

EXPLODED VIEW FOR PARTS LIST