

#12 ELECTRIC MEAT GRINDER

OWNER'S MANUAL



WARNING

Read carefully and understand RULES FOR SAFE OPERATION and instructions before operating. Failure to follow the safety rules and other basic safety precautions may result in serious personal injury.

ITEM# 151342

#12 ELECTRIC MEAT GRINDER

OWNER'S MANUAL

Thank you very much for choosing a Kitchener™ product! For future reference, please complete the owner's record below:

Model: _____ Purchase Date: _____

Save the receipt, warranty and these instructions. It is important that you read the entire manual to become familiar with this product before you begin using it.

This machine is designed for certain applications only. The distributor strongly recommends this machine is not modified and/or used for any application other than that for which it was designed. If you have any questions relative to a particular application, DO NOT use the machine until you have first contacted the distributor to determine if it can or should be performed on the product.

For technical questions and replacement parts, please call 1-800-222-5381.



TECHNICAL SPECIFICATIONS

HP	0.5 HP
Volts	110V
Watts	350W
Neck	#12
Overall Dimensions (L x W x H)	16.5x7.4x14.3in.
Capacity Per Hour	176lbs.
Size of Plate Holes	3/16in. (4.5mm), 5/16in.(8mm), 3/8in. (10mm)

GENERAL SAFETY RULES

WARNING: Read and understand all instructions. Failure to follow all instructions listed below may result in electric shock, fire and/or serious injury.

WARNING: The warnings, cautions, and instructions discussed in this instruction manual cannot cover all possible conditions or situations that could occur. It must be understood by the operator that common sense and caution are factors which cannot be built into this product, but must be supplied by the operator.

SAVE THESE INSTRUCTIONS

WARNING: YOUR SAFETY IS THE MOST IMPORTANT ISSUE WHEN USING ANY ELECTRICAL PRODUCT. BASIC SAFETY PRECAUTIONS MUST ALWAYS BE FOLLOWED!

- **ALWAYS** disconnect unit from power source before servicing unit.
- **NEVER** use this appliance outdoors or in a wet or damp environment. Never allow power cord to be exposed to water or any other liquid. Electrical shock may cause serious injury or even death.
- **ALWAYS** check grinder for any damaged parts prior to using, including power cord.
- **NEVER** modify power cord or plug in any way. **ALWAYS** use the proper outlet with a 3 prong grounded line.
- **ALWAYS** make sure the power switch is in the off position before plugging in or removing the unit's power cord. **NEVER** use the cord to remove the plug from the outlet.
- **NEVER** use the appliance in an area where the cord is exposed to possible entanglement. **ALWAYS** protect the cord from being snagged as this could cause the appliance to be turned over.
- **NEVER** attempt to operate this appliance while under the influence of alcohol, drugs or medications.
- **NEVER** leave your appliance unattended. **ALWAYS** turn off the power switch and disconnect the unit from the power source before leaving the work area.
- **ALWAYS** keep children and inexperienced users a safe distance away from this appliance. Children and inexperienced users should never be allowed to operate this unit.

#12 ELECTRIC MEAT GRINDER

OWNER'S MANUAL

- Trim all excess tendons, cartilage, cords, blood clots and remove meat from bones.
- **NEVER** leave this appliance unattended while it is in operation or while connected to a power source, which would allow anyone unqualified to turn on this unit.
- **ALWAYS** make certain the appliance is seated firmly on a level, stable surface.
- **NEVER** operate this appliance without animal meat in the unit. Severe damage can occur if unit is run for any length of time without product in the unit.
- **ALWAYS** tie back loose hair and clothing before attempting to operate this appliance and roll back any long sleeves you may be wearing.
- **ALWAYS** remove any rings, watches, bracelets or other jewelry before attempting to operate this appliance. Not doing so could cause serious injury and damage the unit.
- **ALWAYS** wear eye protection (safety goggles) when operating this appliance.

⚠ WARNING: **NEVER** use fingers to push meat into hopper intake. Doing so could result in loss of appendages and serious injury. Always use food plunger.

⚠ WARNING: **NEVER** use hands or fingers to pull or scrape meat away from the grinding plate outlet. Doing so could result in loss of appendages and serious injury.

- **NEVER** extend your reach or reach over any object to feed the grinder. Keep a stable balance and firm footing at all times.
- **NEVER** insert any foreign object into this appliance. Always use the accessories that were provided with your unit.
- **ALWAYS** turn off and disconnect the appliance if it becomes jammed. Wait until the unit has come to a complete stop before attempting to remove any jammed matter.
- **NEVER** force this appliance to operate beyond its designed rate. Trying to push the unit will only result in problems. Practice safety and allow the unit to work properly.
- **NEVER** attempt to grind bones, cartilage or tendons. Make sure all metal matter (bullets, shot, etc.) have been removed from all meat.
- **ALWAYS** allow all moving parts to come to a complete stop before using the reverse mode. Reverse mode is designed to run for only a few seconds. Prolonged usage will result in damage to the unit's motor. Hitting the reverse mode while the unit is still running will also damage the motor.
- **NEVER** attempt to remove or attach the hopper tray, grinder head, locking cap or other accessories while the appliance is in operation or plugged into the power outlet.

ASSEMBLY AND OPERATION INSTRUCTIONS

Before Use:

- Disassemble the grinder head and wash each part thoroughly in warm soapy water, removing all food-grade packing grease and oil from the surfaces. Dry all parts before re-assembly.
- Keep packing material for future storage of grinder and grinder parts.

Assembly Instructions:

- Insert grinder head into gear housing; be sure that the hopper tray throat is facing upward. Holding grinder head with one hand, place locking knob into the hole on the side of Motor housing and tighten it clockwise (See Fig 1).

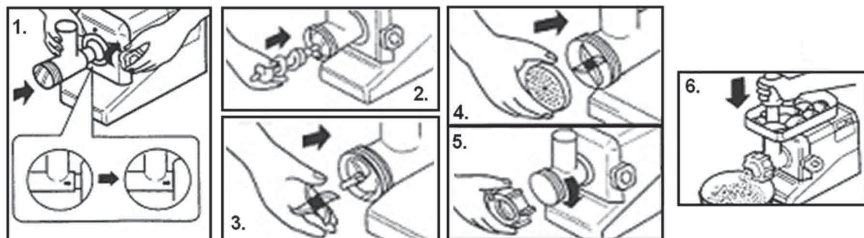

#12 ELECTRIC MEAT GRINDER

OWNER'S MANUAL

- Insert auger into the grinder head. You may need to turn the auger to align it with the drive shaft of the motor (See Fig 2).
- Place cutting knife blade onto Feed Screw shaft of the auger with the Flat edge of blade facing the front (See Fig 3).
- If blade is not seated properly, meat will not be ground.
- Place desired grinding plate next to Cutting Blade. The notch in the plate should align with the protrusion on the grinder head (See Fig 4).
- Firmly screw ring cap onto grinder head. Do not over tighten (See Fig 5).
- Insert the Hopper meat tray onto the throat of the head (See Fig 6).

Grinding Instructions:

- For best results, trim all excess tendons, cartilage, cords and blood clots and remove meat from bones.
- Optimal results occur when meat is chilled to 32-34°F before grinding.
- Cut meat into pieces that will easily fit in throat of grinder head. (Approximately 1in. squares.)
- Place cubed meat into tray. Be sure not to over fill the tray. Make sure the throat opening of the tray remains clear and open.
- Place a dish, bowl or tray under grinder head to catch ground meat.
- Switch grinder to on position. Carefully begin to feed meat down the throat. Use plunger to push meat. **DO NOT use fingers or utensils other than the plunger provided;** bodily injury may occur and you could damage your grinder.

If Jamming Occurs Or Performance Slows:

- ⚠ WARNING:** Shut grinder off immediately and remove power cord from outlet.
- Carefully remove Grinder head ring cap, grinder plate and cutting blade.
 - Carefully clean grinder plate holes thoroughly and remove any tendons from around cutting blade.
 - Replace cutting blade, grinder plate and screw ring cap back onto grinder head.
 - Continue grinding
 - Repeat steps as necessary to enhance grinder performance.

Grinders Reverse Function:

- Switch off the machine.
- Switch CIRCUIT BREAKER to reset.
- Press OFF/REVERSE to clear any materials that are jamming the machine.
- Reverse operation will continue for as long as OFF/REVERSE is pressed.
- Extended use of Reverse is not recommended and will cause damage to motor.
- If performance remains slow or there is still a jam go to steps under "If jamming occurs or Performance slows" above and repeat as needed.

Sausage Stuffing Directions:

- Properly prepare casings as directed on casing packaging. Place artificial or natural intestines onto sausage funnel.
- Load hopper with prepared meat and feed meat into grinder head opening before operating unit. Do not operate grinder without meat in grinder head. Damage to auger and/or motor can occur.
- Plug in and turn switch to on position when ready to start.
- Hold the casing on the sausage tube in one hand and slowly let the meat output pull the casing from the tube. Fill casing as desired by holding casing back on tube.
- Twist or tie the sausage into links as desired. Tie end of casing into a knot.
- It is recommended that 2 people perform sausage stuffing.
- Add small amounts of water to your ground meat when stuffing sausage to improve output of meat through sausage stuffing tube.

#12 ELECTRIC MEAT GRINDER

OWNER'S MANUAL

Kubbe Attachment Instructions (see fig 7, 8 and 9 below):

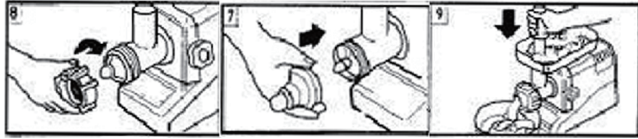

- Be sure grinder is unplugged.
- Attach grinder head to motor and install auger as previously described in the general assembly instructions.
- Place Kubbe flange over the Kubbe attachment and slide them directly onto auger. Grinding blade is not used when stuffing.
- Place the Grinder ring onto grinder head and tighten grinder ring onto. Grinder head firmly seating Kubbe attachment into place.
- Load hopper tray with prepared Kubbe dough.
- Plug in grinder and turn on switch.
- Feed dough into grinder throat and let the dough extrude.
- Once finished cut the dough to desired lengths.
- You now have the finished outer shell for Kubbe.
- By sealing one end you can now stuff the interior of the outer shell with your choice of fillings.

After Use:

- Unplug and disassemble all parts and wash thoroughly in soapy water.
- **NOTE: Do not place parts in a dishwasher; wash all parts by hand.**
- You must remove all foreign material from all appliance parts. (Grinding stale bread may help remove food residue.)
- Dry all surfaces.
- Do not use bleach or chlorine-based chemicals to clean. Discoloration of plastic parts can occur.
- Wipe down all non stainless steel parts with a food grade spray. Alternatively, wipe down with a salad oil to keep from rusting.
- Do not immerse motor housing in water. Damage to motor can occur. Wipe with damp cloth to clean.

TROUBLE SHOOTING

PROBLEMS	SOLUTIONS
Grinder has no power	Check power to outlet. Make sure unit is securely plugged into outlet
Grinder has no power, but outlet does	First, check and reset circuit breaker. Problem may be with switch or power cord. Contact customer service.
Grinder hums or runs in only one direction	Grinder has switch or internal problem. Try resetting circuit breaker. Contact customer service.
Grinder hums or labors to operate	Possible cold gear grease problem. Move grinder to warmer area. If this does not work contact customer service.
Grinder runs slowly and erratically	Possible cold gear grease problem. Move grinder to warmer area. If this does not work contact customer service.
Meat is backing up at the back of the grinder	Auger is not able to handle large portions of meat. Cut meat into smaller pieces so auger can work properly.
Meat is only turning around the auger and compressing against the head	Meat is too warm. Cool meat to a temperature around 40°.
Meat does not flow through grinder	Make sure grinder head is properly assembled. Check sharpness of knife blade.
Meat is backing up at head and will not flow	Meat may be snagging on the auger or other parts. Lubricate internal parts with food-grade silicone spray.

#12 ELECTRIC MEAT GRINDER

OWNER'S MANUAL

DIAGRAM AND PART LIST

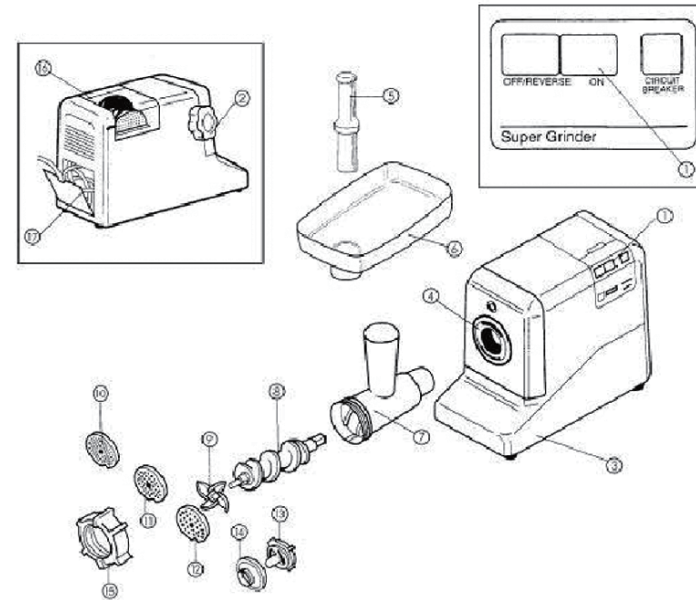

PARTS#	DESCRIPTION	Quantity	PARTS#	DESCRIPTION	Quantity
1	Switch	1	10-14	Attachments	
2	Locking Knob	1	10	Cutting Plate (fine)	1
3	Motor Housing	1	11	Cutting Plate (medium)	1
4	Opening	1	12	Cutting Plate (coarse)	1
5	Food Pusher	1	13	Kubbe attachment (A)	1
6	Hopper Plate	1	14	Kubbe attachment (B)	1
7	Head	1	15	Cap	1
8	Feed Screw	1	16	Cutters	1
9	Cutting Blade	1	17	Cord compartment	1

For technical questions and replacement parts, please call **1-800-222-5381**.

WARRANTY
One-Year Limited Warranty



Distributed by
Northern Tool + Equipment Co., Inc.
Burnsville, MN 55306-6936
Made in China