



**YELLOW
JACKIT**

By



**Air-Operated Hydraulic Pressure Jack
10771
(OPERATION INSTRUCTION)**

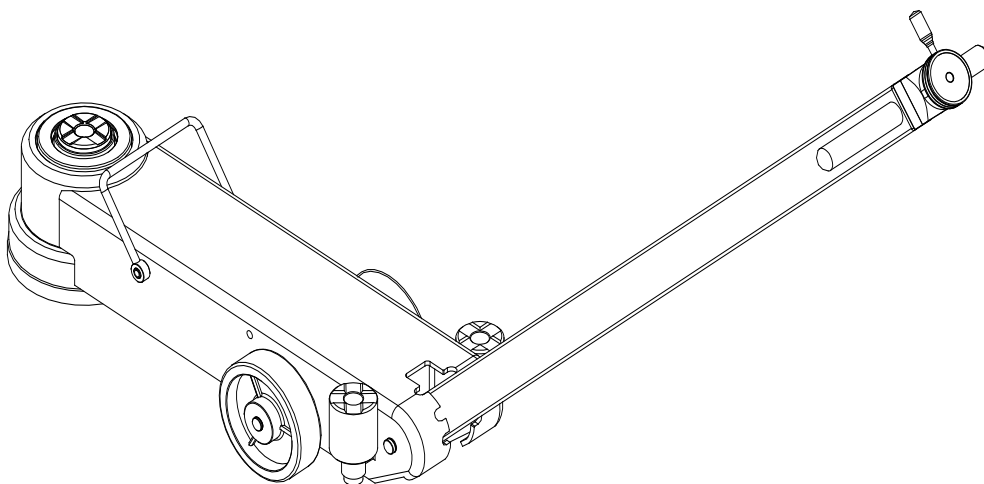



Please read the warnings and instructions carefully in the present manual since they are concerning the important indications and safety of operation and maintenance. The Manufacturer is in no way responsible for eventual damages to persons, animals or equipments caused by improper, erroneous, incorrect and unreasonable application.

1. Application: Air-operated hydraulic pressure jack is a newly-type lifting equipment. It utilizes compressed air to promote booster cylinder, to make the hydraulic oil which is stored in oil tank infuse into oil cylinder to move hydraulic cylinder up & down. It adopts the machinery design combination of hydraulic pressure with great advantages of delicate design, small dimension, convenient moving, wide scope of usage, strong jacking capacity and low lifting part. It is a convenient lifting equipment and low labor intensity of automobile manufacturing, repairing, engineering mechanism or heavy-facility.

2. Specification & Parameter.

Model No.	10771
Jacking Capacity	50T/25T/10T/
Air Pressure	0.62-0.9Mpa
Lowest Height	5.5”
Hoisting Height	50T: 2.2” 25T: 2” 10T: 2.2”
Weight	143 lbs.

3. Safety Notice

- (1) Install the operation rod and host together with fixed axis of operation rod. Place the retaining ring in good order. Insert the air-operated connectors into pipe connectors according to their different outer size. Pull the locked operation rod to carry out 3 different directions: lever direction of operation rod & host, direction of 45 degrees and 90 degrees. (As for operation procedure, please see the label of <Air-operated hydraulic pressure Jack installation instruction> which sticks on the operation rod.)
- (2) Make reasonable choice of clean and dry air pressure (Grease filter much be installed on the air resource), its application scope should be 0.62-0.9Mpa (The MAX. air pressure of safety valve is 0.9 Mpa) and within the rated air pressure scope to guarantee life.
- (3) Connect it with air pipe. (See picture A)
- (4) Place the air-operated hydraulic pressure jack on a stable, flat, resistant, dry surface without drains or holes when using. If necessary, place a wood board under the air-operated hydraulic pressure jack to avoid any deflection. (Please carefully read the label of <Warnings> which sticks on the operation rod.)
- (5) When lifting, place some secured stands or solid supports on the suitable area under raised vehicle to assure security.
- (6) Before lifting, please estimate the weight of object and vehicles to avoid overload. The life of equipment will be affected strongly if it is overloaded.



- (7) The air-operated hydraulic pressure jack uses 32# hydraulic oil. Make sure there is enough filtered & clean hydraulic oil to support the jack, or the jack is unable to reach its rated hoisting height. If it lacks oil, please screw off the bolt of the oil tank's filling opening and fill a suitable amount of oil then screw on.
- (8) Don't shake it sharply when using. To move the air-operated hydraulic pressure jack, please keep the wheels balanced with the operation rod in an intermediate position.
- (9) Don't place the equipment upside down when using.
- (10) Please keep the equipment cleaned & out of the reach of children when not using.
- (11) It is natural & normal to appear a little bit of oil leaking when transporting, loading and using it in the first time.

4. Transport:

The equipment should be packed in a carton. Please see the carrying position as shown in the picture below:

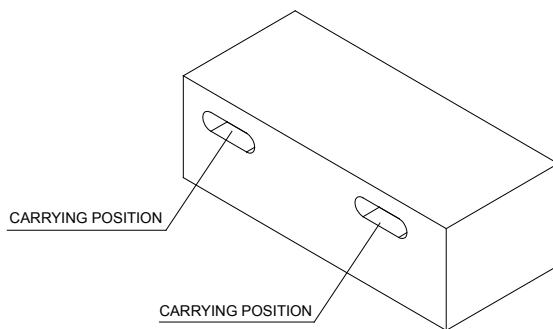

Notice:

1. Carry the equipment with hands in the (carrying position), see picture on the left side.
2. Please operate it according to the relative warning indication which sticks on the carton.
3. The operator can move the equipment to any places with the help of the operation rod and wheels.

5. Equipment Installation, Disassembly and Test.

(1) Equipment installation, when disassembled, please see (pictures A/B/C/D/E/F).

(2) Equipment Test:

- a. When the equipment is off load within the rated air pressure scope, operate the handle of the hand valve clockwise to make the jack move up to the rated hoisting height. After reaching the rated hoisting height, the boosting system stops working automatically (The MAX. air pressure of the safety valve is 0.9Mpa). Operate the handle of the hand valve anticlockwise to make the jack move down. The dustband and sealing of the cylinder work in good order without gas leaking.
- b. Test the equipment with a heavy load by a special testing machine. It is able to reach the rated jacking capacity and hoisting height within the rated air pressure scope. The dustband and sealing of the cylinder work in good order without gas leaking. (The MAX. air pressure of the safety valve is 0.9Mpa)

6. Operation and Maintenance.

(1) Operation of air-operated hydraulic pressure jack.

- a. Operate the handle of the hand valve clockwise to carry out lifting. When the equipment is lifted to the rated height then it will stop lifting automatically by itself with the limitation system.
- b. Operate the handle of the hand valve anticlockwise to carry out moving down. The equipment will move down automatically by itself with a reasonable design principle of air structure.

(2) Equipment maintenance and troubleshooting.



1) Equipment maintenance.

- a. Add a few drops of lubricating oil regularly on the air inlet every 30 days once.
- b. Don't keep it at the acid, alkali and corrosive working place.
- d. Check the oil tank to make sure whether there is enough hydraulic oil or not every 30 days once.
- c. Keep it clean daily after using.

2) The Way of Troubleshooting.

Condition	Possible reason	Troubleshooting
Gas-leak under the host	Connector or air pipe doesn't connect in a right way, or air pipe is broken.	Connect again or replace the air pipe or connector after checking.
Gas-leak on oil cylinder	Dust band or sealing and cylinder are broken	Check and replace the dust band or sealing or spare parts.
A little bit of oil leak	Oil runs into air pipe during the course of transporting.	It is unnecessary to repair if it works in good order
A great deal of oil leak	<ol style="list-style-type: none"> 1. The equipment started under the condition of turnover. 2. Connector of oil inlet or sealing of oil cylinder is broken. 3. Inside wall of cylinder is broken 	<ol style="list-style-type: none"> 1. Starting the equipment under the condition of turnover is strictly prohibited. If it is not in this condition, check and make sure whether there is enough oil in oil tank or not, if not, it should add more. 2. Check and replace spare parts. 3. Check and repair cylinder.
Booster pump does not work	<ol style="list-style-type: none"> 1. One-way valve or spring is broken. (see picture B) 2. Booster piston or booster cylinder is broken 3. Air pressure is not enough, air pipe removed or air inlet is plugged up. 	<ol style="list-style-type: none"> 1. Check and replace the spare part. 2. Check and repair, replace the spare part if necessary. 3. Check the air pressure whether is within 0.62-0.9Mpa and the air way is broken or not.
Booster pump works in good order but cylinder does not move up.	<ol style="list-style-type: none"> 1. Lack of oil. 2. The steel ball of one-way valve is plugged up. 3. Oil Cylinder is broken. 	<ol style="list-style-type: none"> 1. Fill it with hydraulic oil. 2. Take the connector of oil inlet apart and take out the one-way valve and spring to clean it. 3. Check and repair cylinder.



It works with off load but it does not move up or move up slowly with heavy load.	1. Air pressure is not enough, air pipe removed or air inlet is plug up. 2. one-way valve is plugged up. 3. Hydraulic oil became thick	1. Check the air pressure whether is within 0.62-0.9Mpa and the air way is broken or not. 2. Check and Take every one-way valve apart and clean them. 3. Replace the hydraulic oil.
--	---	--

7. Warning:

- (1). Air-operated hydraulic pressure jack is a lifting tool when using. It can not be used as a supporting tool. Without any secured stands or solid supports on the suitable area under raised vehicle to assure security, any operators are strictly prohibited to work after the equipment moved up. (Please carefully read the label of <Warnings> which sticks to the operation rod).
- (2). Use the Air-operated hydraulic pressure jack on a flat and resistant surface away from drains and holes. It is not allowed to use it on a slope floor to avoid lifting objects moving or slipping, especially those vehicle. Make sure to place some supports under the wheel to avoid slip then the equipment can be moved up or down. (Please carefully read the label of <Warnings> which sticks to the operation rod).
- (3). Always respect production requirement and use the equipment within the scope of jacking capacity. Don't be against the operation instruction to use it with overload.
- (4). Use clean and dry air pressure. its application scope should be 0.62-0.9Mpa and at the same time to apply the filtered & clean 32# hydraulic oil. (The MAX. air pressure of safety valve is 0.9 Mpa)

8. Attachment:

- (1). The equipment is with long extension rod and middle extension rod together. Please fix them tightly with rope during the course of transportation to avoid damaging the host.
- (2). The operation rod is packed in another carton. Please take it out and install it in the host according to the installation indication of operation rod.