



**Blackhawk
Automotive**™

Blackhawk Automotive is a Licensed Trade Mark

Made by ©SFA Companies, Kansas City, MO

Hydraulic Bottle Jacks

Operating Instructions & Parts Manual

Model	Capacity
BH2020	2 Ton
BH2040	4 Ton
BH2060	6 Ton
BH2080	8 Ton
BH2120, BH2125	12 Ton
BH2200, BH2205	20 Ton
BH2300	30 Ton



This is the safety alert symbol. It is used to alert you to potential personal injury hazards. Obey all safety messages that follow this symbol to avoid possible injury or death.

ADVERTENCIA

- Leer, comprender, y seguir las instrucciones antes de utilizar el aparato.
- El manual de instrucciones y la información de seguridad deben estar comunicados en lengua del operador antes del uso.
- No seguir estas indicaciones puede causar daños personales o materiales.

WARNING

To avoid **crushing and related injuries**:



NEVER work on, under or around a load supported only by a hydraulic jack. **ALWAYS** use adequately rated jack stands.

SFA Companies
10939 N. Pomona Ave. Kansas City, MO 64153
sales@blackhawk-automotive.com

Read this manual and follow all the Safety Rules and Operating Instructions before using this product.

Made in PRC
BH2020-M0 11/07

SAFETY and GENERAL INFORMATION

Save these instructions. For your safety *read, understand, and follow* the information provided with and on this jack. The owner and operator of this equipment shall have an understanding of this jack and safe operating procedures before attempting to use. The owner and operator shall be aware that use and repair of this product may require special skills and knowledge. Instructions and safety information shall be conveyed in the operator's native language before use of this jack is authorized. If any doubt exists as to the safe and proper use of this jack, remove from service immediately.

Inspect before each use. Do not use if broken, bent, cracked, or damaged parts (including labels) are noted. Any jack that appears damaged in any way, operates abnormally or is missing parts, shall be removed from service immediately and the manufacturer notified. If you suspect that the jack was subjected to a shock load (a load dropped suddenly, unexpectedly upon it), immediately discontinue use until the jack has been checked by a factory authorized service center (contact distributor or manufacturer for list of Authorized Service Centers). It is recommended that an annual inspection be done by qualified personnel. Replace worn or damaged parts with Blackhawk authorized replacement parts only. Labels and owner's manuals are available from manufacturer.

PRODUCT DESCRIPTION

Blackhawk Automotive Hydraulic Bottle Jacks are designed to lift, not support, rated capacity loads consisting of one end of a vehicle. Immediately after lifting, the load must be supported by a pair of appropriately rated jack stands.



Never use hydraulic jack as a stand alone device. After lifting, **immediately** support the lifted load with a pair of appropriately rated jack stands.

SPECIFICATIONS

Model	Capacity	Base Size (L x W)	Min. Height	Max. Height	Extension Screw	Volume Hyd. Oil	Net Weight
BH2020	2 Ton	3 3/4" x 3 5/8"	7 1/4"	13 5/8"	2"	101 mL	5.7 lb
BH2040	4 Ton	4" x 3 7/8"	8"	15 3/8"	2 3/8"	178 mL	8.4 lb
BH2060	6 Ton	4 1/4" x 4"	8 5/8"	16 3/4"	3"	264 mL	10.1 lb
BH2080	8 Ton	4 3/4" x 4 3/4"	8 7/8"	17 5/8"	2 3/4"	250 mL	12.7 lb
BH2120	12 Ton	5 1/4" x 5 1/8"	9 1/2"	18 5/8"	3 1/8"	336 mL	17.5 lb
BH2125			6"	10 5/8"	1 5/8"	185 mL	13.7 lb
BH2200	20 Ton	6 1/4" x 5 7/8"	9 1/2"	18 5/8"	3 1/8"	498 mL	27.5 lb
BH2205			6 1/2"	11 1/4"	1 5/8"	275 mL	20.7 lb
BH2300	30 Ton	8 1/8" x 6 7/8"	11"	18"	N/A	890 mL	53.6 lb

PREPARATION

Before Use

1. Verify that the product and the application are compatible, if in doubt contact Customer Support (816)891-6390.
2. Before using this product, read the operator's manual completely and familiarize yourself thoroughly with the product, its components and recognize the hazards associated with its use.
3. Assemble handle, ensure spring clips align with slots.
4. To familiarize yourself with basic operation, use the notched end of provided handle to engage and turn the release valve:
 - a. Clockwise until firm resistance is felt to further turning. This is the '**CLOSED**' release valve position used to **raise** the ram plunger.
 - b. Counter-clockwise, but no more than 1/2 turn from the closed position. This is the '**OPEN**' release valve position used to **lower** the ram plunger.
5. With ram fully retracted, locate and remove the oil filler plug/screw. Insert the handle into the handle sleeve, then pump 6 to 8 strokes. This will help release any pressurized air, which may be trapped within the reservoir. Ensure the oil level is just below the oil filler hole. Reinstall the oil filler plug/screw.
6. Check that the pump operates smoothly and that the extension screw will thread up/down easily before putting into service. Replace worn or damaged parts and assemblies with Blackhawk Automotive authorized replacement parts only.

Bleeding / Venting Trapped Air

With the release valve in the OPEN position (4b above) and with ram plunger fully lowered, locate and remove the oil filler plug/screw. Insert the handle into the handle sleeve; then pump 6 to 8 full strokes. This will help release any pressurized air which may be trapped within the reservoir. Oil level should be even with the bottom of the oil filler hole. Reinstall the oil filler plug/screw.

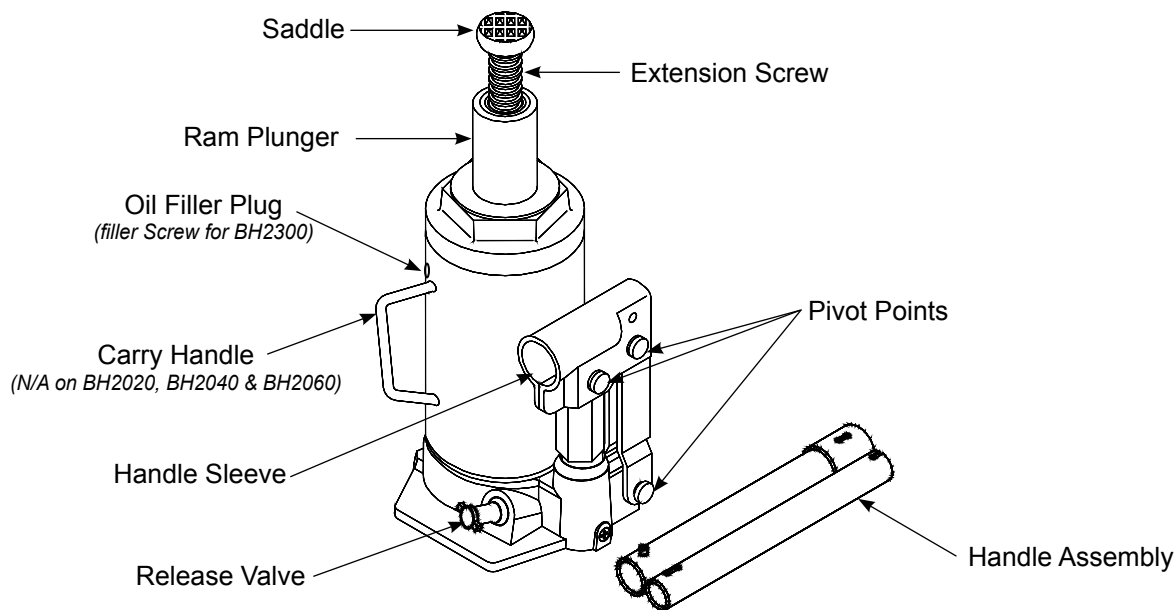
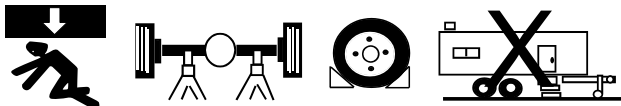

Figure 1 - Typical Bottle Jack Nomenclature (BH2200 shown)

⚠ WARNING

- **Study, understand, and follow** all printed materials provided with/on this product before use.
- **Do not** exceed rated capacity.
- **This is a lifting device only!**
- **Immediately** after lifting, support the load with **a pair** of appropriately rated jack stands.
- Use only on hard, level surface.
- Do not use adapters or accessories that are not provided initially.
- Lift only on areas of the vehicle as specified by the vehicle manufacturer.
- No alterations shall be made to this product.
- Failure to heed these markings may result in personal injury and/or property damage.

⚠ WARNING



To avoid **crushing and related injuries**:

- **Never** work on, under or around a load supported only by hydraulic jack.
- **Always** use adequately rated jack stands.
- Chock each unlifted tire in both directions.
- **Do not** use this device to lift, level, lower, support nor move a house, mobile home, travel trailer, camper or any building structure.
- **Be alert and sober** when using this product. Do not operate under the influence of drugs or alcohol.

⚠ *Only attachments and/or adapters supplied by the manufacturer shall be used. Use **ONLY** on vehicles whose lift points are compatible with the saddle of the jack! Lift only on areas of the vehicle as specified by the vehicle manufacturer.*

OPERATION

Raising the Ram Plunger

1. Assemble handle, ensure that spring clips align with slots.
2. Place vehicle in the park, with emergency brake on and wheel securely chocked to prevent inadvertent vehicle movement.
3. Locate and close release valve by turning handle clockwise until firm resistance is felt to further thread engagement.
4. Verify lift point, center jack saddle under lift point.
5. Insert handle into handle sleeve and pump to contact lift point. To lift, continue pumping until load reaches desired height.
6. **Immediately** transfer the lifted load to a pair of appropriately rated jack stands.

⚠ *Use only handle provided by jack manufacturer. The handle provided with this jack will safely engage the release valve and operate the handle sleeve. If handle is worn, operates abnormally, or will not positively engage the release valve, **STOP**, discontinue use of the jack until a factory replacement handle can be acquired.*

Lowering

⚠ *Make certain that all personnel are clear of the load before lowering. **Control** the rate of descent of the load **at all times**. The **more** you open the release valve, the **faster** the load descends.*

1. Raise load high enough to clear the jack stands, then carefully remove jack stands (**always** used in pairs).
2. Slowly turn the handle counter-clockwise, but no more than 1/2 turn. If the load fails to lower:
 - a. Use another jack to raise the vehicle high enough to reinstall jack stands.
 - b. Remove the affected jack and then the stands.
 - c. Lower the load by turning the release valve counter-clockwise, but no more than 1/2 turn.
3. After removing jack from under the load, push ram and handle sleeve down to reduce exposure to rust and contamination.

MAINTENANCE

Important: Use only a good grade hydraulic jack oil. Avoid mixing different types of fluid and NEVER use brake fluid, turbine oil, transmission fluid, motor oil or glycerin. Improper fluid can cause premature failure of the jack and the potential for sudden and immediate loss of load. We recommend Hein-Werner HW93291 or equivalent.

Adding oil

1. With ram plunger fully lowered and pump piston fully depressed, set jack in its upright, level position. Remove oil filler plug/screw.
2. Fill with oil until just below the rim of the oil filler hole. Reinstall the oil filler plug/screw.

Changing oil

For best performance and longest life, replace the complete fluid supply at least once per year.

1. With ram plunger fully lowered and pump piston fully depressed, remove the oil filler plug/screw.
2. Lay the jack on its side and drain the fluid into a suitable container.

Note: Dispose of hydraulic oil in accordance with local regulations.

3. Fill with oil until just below the rim of the oil filler hole. Reinstall the oil filler plug/screw.

Lubrication

A periodic coating of light lubricating oil to pivot points, axles and hinges will help to prevent rust and assure that pump assemblies move freely.

Cleaning

Periodically check the pump piston and ram for signs of rust or corrosion. Clean as needed and wipe with an oily cloth.

Note: Never use sandpaper or abrasive material on these surfaces!

Storage

When not in use, store the jack with pump piston and ram plunger fully retracted and air supply disconnected.

TROUBLESHOOTING

Symptom	Possible Causes	Corrective Action
Jack will not lift load	<ul style="list-style-type: none">• Release valve not tightly closed• Overload condition	<ul style="list-style-type: none">• Ensure release valve tightly closed• Remedy overload condition
Jack will lift, but not maintain pressure	<ul style="list-style-type: none">• Release valve not tightly closed• Hydraulic unit malfunction	<ul style="list-style-type: none">• Ensure release valve tightly closed• Contact Blackhawk Tech. Service
Jack will not lower after unloading	<ul style="list-style-type: none">• Reservoir overfilled	<ul style="list-style-type: none">• Ensure load is removed, then drain fluid to proper level
Poor lift performance	<ul style="list-style-type: none">• Fluid level low• Air trapped in system	<ul style="list-style-type: none">• Ensure proper fluid level• With ram fully retracted, remove oil filler plug to let pressurized air escape, then reinstall oil filler plug/screw
Will not lift to full extension	<ul style="list-style-type: none">• Fluid level low	<ul style="list-style-type: none">• Ensure proper fluid level

REPLACEMENT PARTS

Not all components of the jack are replacement items. When ordering parts, give Model number, serial number and parts description. Call or write for current pricing: SFA Companies Inc. 10939 N. Pomona Ave. Kansas City, MO 64153, U.S.A. Tel: (816)891-6390 Fax: (816)891-6599 E-Mail: sales@blackhawk-automotive.com

Replacement Parts List for Models BH2020, BH2040, BH2060, BH2080, BH2120, BH2125, BH2200 & BH2205

Item	Part# for Model:		Description	Qty
	BH2020, BH2040 & BH2060	BH2080, BH2120, BH2125, BH2200 & BH2205		
1	F36100-0001		Oil Filler Plug	1
2	B20207-0002	B21207-0002	Handle Assembly	1
3	B80200-0001		Release Valve Assembly	1
-	B20207-0001 (for BH2020) B20407-0001 (for BH2040) B20607-0001 (for BH2060)	B20807-0001 (for BH2080) B21207-0001 (for BH2120 & BH2125) B22007-0000 (for BH2200 & BH2205)	Repair Kit (includes all soft seals, oil filler plug & release valve assembly)	-

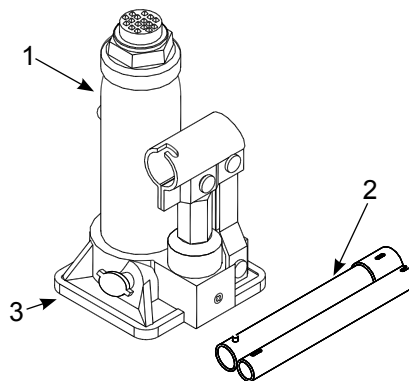

Figure 2 - Illustration for Model BH2020, BH2040 & BH2060

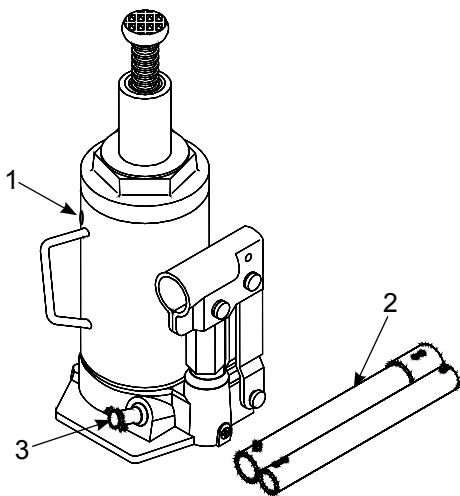

Figure 3 - Illustration for Model BH2080, BH2120 & BH2200

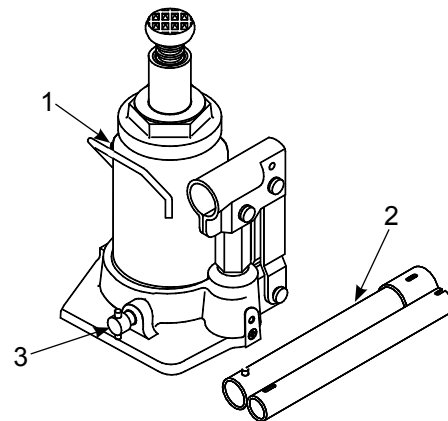

Figure 4 - Illustration for Model BH2125 & BH2205

Replacement Parts List for Model BH2300

Item	Part# for BH2300	Description	Qty
1	G62S-03301-000	Oil Filler Screw	1
2	B300-17000-000	Handle Assembly	1
3	BT02-17100-000	Release Valve	1
-	B3000S-034	Repair Kit (<i>includes all soft seals</i>)	-

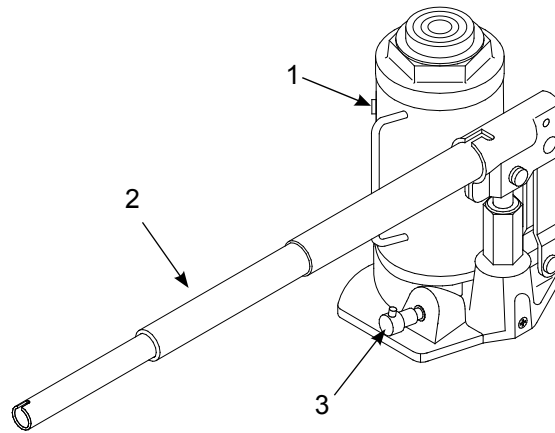

Figure 5 - Illustration for Model BH2300

ONE YEAR LIMITED WARRANTY

For a period of one (1) year from date of purchase, SFA Companies will repair or replace, at its option, without charge, any of its products which fails due to a defect in material or workmanship under normal usage. This limited warranty is a consumer's exclusive remedy.

Performance of any obligation under this warranty may be obtained by returning the warranted product, freight prepaid, to SFA Companies Warranty Service Department, 10939 N. Pomona Ave., Kansas City, MO 64153.

Except where such limitations and exclusions are specifically prohibited by applicable law,

(1) THE CONSUMER'S SOLE AND EXCLUSIVE REMEDY SHALL BE THE REPAIR OR REPLACEMENT OF DEFECTIVE PRODUCTS AS DESCRIBED ABOVE.

(2) SFA Companies SHALL NOT BE LIABLE FOR ANY CONSEQUENTIAL OR INCIDENTAL DAMAGE OR LOSS WHATSOEVER.

(3) ANY IMPLIED WARRANTIES, INCLUDING WITHOUT LIMITATION THE IMPLIED WARRANTIES OF MERCHANTABILITY AND FITNESS FOR A PARTICULAR PURPOSE, SHALL BE LIMITED TO ONE YEAR, OTHERWISE THE REPAIR, REPLACEMENT OR REFUND AS PROVIDED UNDER THIS EXPRESS LIMITED WARRANTY IS THE EXCLUSIVE REMEDY OF THE CONSUMER, AND IS PROVIDED IN LIEU OF ALL OTHER WARRANTIES, EXPRESS OR IMPLIED.

(4) ANY MODIFICATION, ALTERATION, ABUSE, UNAUTHORIZED SERVICE OR ORNAMENTAL DESIGN VOIDS THIS WARRANTY AND IS NOT COVERED BY THIS WARRANTY.

Some states do not allow limitations on how long an implied warranty lasts, so the above limitation may not apply to you. Some states do not allow the exclusion or limitation of incidental or consequential damages, so the above limitation or exclusion may not apply to you. This warranty gives you specific legal rights, and you may also have other rights, which vary from state to state.



SFA Companies
10939 N. Pomona Ave. Kansas City, MO 64153
816-891-6390
sales@blackhawk-automotive.com