

**⚠ WARNING**

Some dust created by power sanding, sawing, grinding, drilling, and other construction activities contains chemicals known to the State of California to cause cancer, birth defects or other reproductive harm. Some examples of these chemicals are:  
lead from lead-based paints,  
crystalline silica from bricks and cement and other masonry products, and  
arsenic and chromium from chemically treated lumber.

Your risk from these exposures varies, depending on how often you do this type of work. To reduce your exposure to these chemicals: work in a well-ventilated area, and work with approved safety equipment, such as those dust masks that are specially designed to filter out microscopic particles.



Distributed by  
Northern Tool + Equipment Co., Inc.  
2800 Southcross Drive West  
Burnsville, MN 5337-0499  
Made in China.



## 1/4in. AIR ANGLE DIE GRINDER USER'S MANUAL



**⚠ WARNING:**  
Read carefully and understand all INSTRUCTIONS before operating. Failure to follow the safety rules and other basic safety precautions may result in serious personal injury.

7. With a firm grip on the Die Grinder, lightly apply the Grinding drum to the workpiece, slowly and steadily moving the grinding drum to the right and left until you have achieved the desired appearance (finish) on the workpiece.
8. Once the work is completed, release hand pressure on the trigger, the safety will automatically return to its locked position to prevent the trigger from accidentally being activated.
9. Turn off the air compressor. Trip the safety with your finger, and slowly squeeze the trigger to release any remaining air pressure from the die grinder. Then disconnect the air hose from the tool.
10. Remove the grinding drum from the Die Grinder. Then store the tool in a clean, dry location out of reach of children and untrained operators.

## INSPECTION, MAINTENANCE AND CLEANING

1. Always make sure the trigger is in its "OFF" position, and disconnect the Die Grinder from its compressed air supply before performing any inspection, adjustments, maintenance, or cleaning.
2. Before each use, inspect the general condition of the Die Grinder. Check for loose screws, misalignment or binding of moving parts, cracked or broken parts, damaged air hose, and any other condition that may affect its safe operation. If abnormal noise or vibration occurs, have the problem corrected before further use. Do not use damaged equipment.
3. Daily: With a clean cloth, remove all dirt, oil, and grease from the Die Grinder. If necessary, you may use a mild detergent. Do not use solvents, as damaged to the Die Grinder may occur. Do not immerse the Die Grinder in any liquids.

## PARTS LIST

Part#	Description	Qty.	Part#	Description	Qty.
1	Air Inlet	1	16	Bearing	1
2	Muffle Cover	1	17	End Plate	1
3	Housing	1	18	Pin	2
4	Valve Plug	1	19	Rotor Blade	4
5	O-ring	1	20	Rotor	1
6	O-ring	1	21	Cylinder	1
7	Air Regulator	1	22	Front Plate	1
8	Spring	1	23	Bearing	1
9	O-ring	1	24	Washer	1
10	Valve Stem	1	25	Collet Holder	1
11	O-ring	1	26	Retainer	1
12	Steel Ball	1	27	Housing Cap	1
13	Valve Busing	1	28	Collet	1
14	Pin	1	29	Cap	1
15	Trigger	1	30	Wrench	2

For technical questions and replacement parts, please call **1-800-222-5381**.

Thank you very much for choosing a Wel-Bilt™, Product! For future reference, please complete the owner's record below:

**Model:** \_\_\_\_\_ **Purchase Date:** \_\_\_\_\_

Save the receipt, warranty and these instructions. It is important that you read the entire manual to become familiar with this product before using it.

This machine is designed for certain applications only. The distributor strongly recommends that this machine is not modified and/or used for any application other than that for which it was designed. If you have any questions relative to a particular application, DO NOT use the machine until you have first contacted Northern Tool + Equipment to determine if it can or should be performed on the product.

Before using this product, please read the following instructions carefully.

## TECHNICAL SPECIFICATIONS

Item	Description	Item	Description
<b>Collet Capacity</b>	1/4in.	<b>Air Inlet Diameter</b>	1/4in.- 18NPT
<b>Rated Speed</b>	22,000 RPM	<b>Min. Hose Size</b>	3/8in.
<b>Max. Air Pressure</b>	90 PSI Recommended	<b>Accessories</b>	Collet nut wrenches (2pcs.)
<b>Air Consumption</b>	5 CFM		

## SAVE THIS MANUAL

You will need this manual for the safety warnings and precautions, assembly, operating, inspection, maintenance and cleaning procedures, parts list and assembly diagram. Keep this manual and invoice in a safe and dry place for future reference.

## GENERAL SAFETY RULES

Read and understand all instructions.

Failure to follow all instructions listed in the following pages may result in electric shock, fire, and/or serious injury.

## WORK AREA

**1. Keep your work area clean and well lit.** Cluttered benches and dark areas invite accidents.

**2. Do not operate pneumatic tools in explosive atmospheres, such as in the presence of flammable liquids, gases, or dust.** Pneumatic tools create sparks which may ignite flammables.

**3. Keep bystanders, children and pets away while operating a pneumatic tool.**

Distractions can cause you to lose control. Protect others in the work area from debris such as metal filings and sparks. Provide barriers or shields as needed.

DIAGRAM

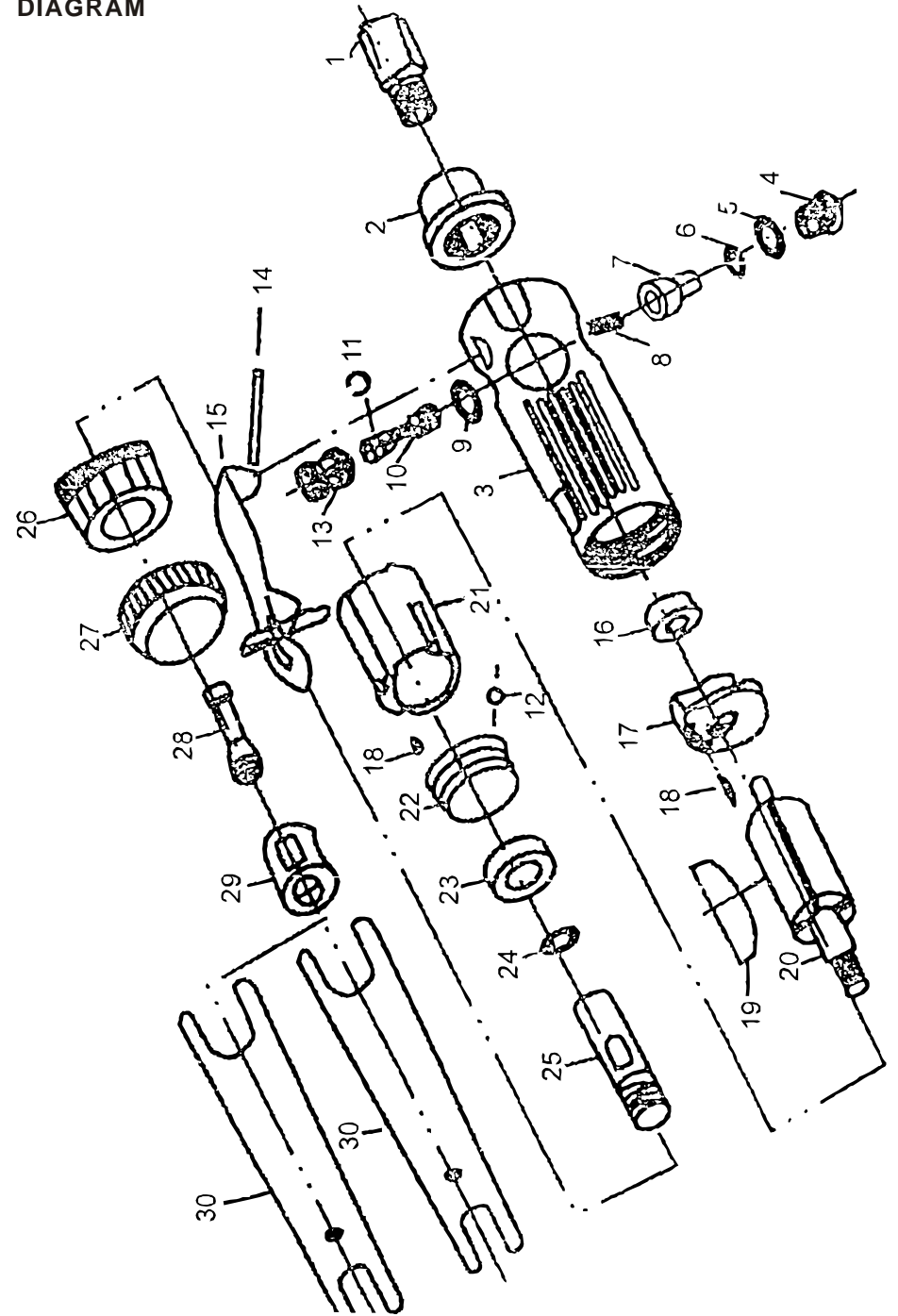

## PERSONAL SAFETY

- 1. Stay alert.** Watch what you are doing, and use commonsense when operating a pneumatic tool. Do not use a pneumatic tool while tired or under the influence of drugs, alcohol, or medication. A moment of inattention while operating pneumatic tools may result in serious personal injury.
- 2. Dress properly.** Do not wear loose clothing or jewelry. Keep your hair, clothing, and gloves away from moving parts. Loose clothes, jewelry, or long hair can be caught in moving parts.
- 3. Avoid accidental starting.** Be sure the trigger is off before connecting to the air supply. Carrying pneumatic tools with your finger on the trigger, or connecting pneumatic tools to the air supply with the trigger on, invites accidents.
- 4. Remove adjusting keys or wrenches before turning on the tool.** A wrench or a key that is left attached to a rotating part of the tool may result in personal injury.
- 5. Do not overreach.** Keep proper footing and balance at all times. Proper footing and balance enables better control of the tool in unexpected situations.
- 6. Use safety equipment.** Always wear ANSI-approved safety glasses underneath a full face shield, and hearing protection.

## USE AND CARE

- Use clamps or other practical ways to secure and support the workpiece to a stable platform. Holding the work by hand is unstable and may lead to loss of control. Only work on a workpiece that is properly secured.
- Do not force the tool. Use the correct tool for your application. The correct tool will do the job better and safer at the rate for which it is designed.
- Do not use the power tool if the trigger does not turn it on or off. Any tool that cannot be controlled with the trigger is dangerous and must be replaced.
- Disconnect the air hose from the tool before making any adjustments, changing accessories, or storing the tool. Such preventive safety measures reduce the risk of starting the tool accidentally.
- Store idle tools out of reach of children and other untrained persons. Tools are dangerous in the hands of untrained users.
- Maintain tools with care. Do not use a damaged tool. Tag damaged tools "Do not use" until repaired.
- Check for misalignment or binding of moving parts, breakages of parts, damaged air hose (not included), and any other condition that may affect the tool's operation. If damaged, have the tool serviced before using. Many accidents are caused by poorly maintained tools.
- Use only accessories that are recommended by the manufacturer for your model. Accessories that may be suitable for one tool may become hazardous when used on another tool.

## SERVICE

- Tool service must be performed only by qualified repair personnel. Service or maintenance performed by unqualified personnel could result in a risk of injury.
- When servicing a tool, use only identical replacement parts. Follow instructions in the "Inspection, Maintenance and Cleaning" section of this manual. Use of unauthorized parts or failure to follow maintenance instructions may create a risk of injury.

## SPECIFIC SAFETY RULES

- To avoid accidental injury, always wear ANSI-approved safety glasses, a full face shield, and hearing protection when operating the Die Grinder.
- Use clean, dry, regulated compressed air at 90 PSI. Do not exceed the recommended 90 PSI. Never use oxygen, carbon dioxide, combustible gases, or any other bottled gas as a power source for this tool.
- When connecting to the air supply: Prior to each use, if an automatic oiler is not used, add two drops of air tool oil (not included) into the air inlet fitting of the Die Grinder.

- Always disconnect the Die Grinder from its compressed air supply source, and squeeze the trigger to release all compressed air in the tool before performing any maintenance or service.
- The warnings, precautions, and instructions discussed in this manual cannot cover all possible conditions and situations that may occur. The operator must understand that common sense and caution are factors which cannot be built into this product, but must be supplied by the operator.

## ASSEMBLY AND OPERATING INSTRUCTIONS TO ATTACH A QUICK CONNECTOR

- ⚠ WARNING!** Prior to performing any assembly and/or adjustment procedures, make sure the air supply hose (not included) is disconnected from the Die Grinder.
- Prior to use, the Die Grinder requires the attachment of a quick-connector into its air inlet. To do so, wrap approximately 3 in. of pipe thread sealer tape (not included) around the male threads of a quick-connector. Then, firmly tighten the quick-connector into the air inlet.

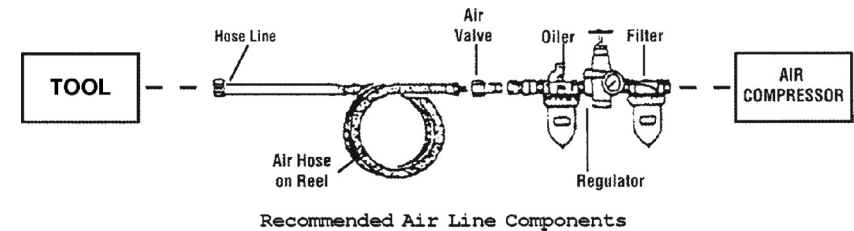

Fig. 1

## TO OPERATE AS A 1/4IN. DIE GRINDER:

- 1. Always wear ANSI-approved safety glasses, a full face shield, and hearing protection when operating the tool.**
- Use the two wrenches provided to loosen the collet nut.
- Insert the 1/4in. diameter shank of a grinding drum (not included) fully into the collet. Then, firmly re-tighten the collet nut to lock both the collet and grinding drum in place.
- Connect the air supply hose to the quick-connector on the Die Grinder. Turn on the air compressor, and set its regulator to the recommended 90 PSI for the Die Grinder.
- 5. IMPORTANT!** Grip the appliance firmly with BOTH hands.
- Trip the safety with your finger. Then slowly apply hand pressure to the trigger until the desired speed is obtained. **NOTE: The tool always turns the Grinding Drum/Drill Chuck clockwise. (See fig. 2)**

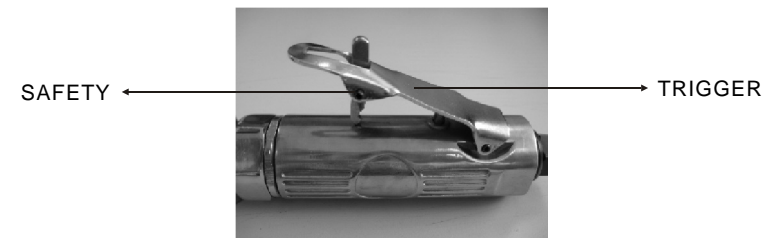

Fig. 2