



INSTRUCTION MANUAL



#14460 AIR HYDRAULIC BOTTLE JACKS



AME INTERNATIONAL

2347 Circuit Way, Brooksville, Florida USA 34604

Phone: (+1) 352.799.1111 • Toll Free: (+1) 877.755.4AME (4263)

Fax: (+1) 352.799.1112 • E-mail: sales@ameintl.net • www.ameintl.net



AME AIR HYDRAULIC BOTTLE JACKS INSTRUCTION MANUAL

Specifications

! WARNING !

FAILURE TO READ THESE WARNINGS MAY RESULT IN PROPERTY DAMAGE AND OR PERSONAL INJURY.

Support load by appropriate means after lifting.

Use as lifting device only.

Do not exceed rated capacity.

Use only on hard, level surface.

Center load on the jack,

Do not modify jack.

Only use attachments and/or adapters supplied with or sold specifically for the jack.

Only lift areas of the vehicle designated by the vehicle manufacturer.

| MODEL | LIFTING CAPACITY | MIN. HEIGHT | 1st STAGE HEIGHT | NET WEIGHT | GROSS WEIGHT | PACKAGE SIZE | AIR PRESSURE |
|-------|------------------|-------------|------------------|------------|--------------|-----------------|--------------|
| 14460 | 20 TON | 245 MM | 475 MM | 16 KG | 18 KG | 31 x 24 x 31 MM | 0.7-1.0 MPa |

Owner/Operator Responsibility

It is the owner/operator responsibility to properly use and maintain this equipment and the legibility of all warnings and instruction labels. Carefully read and understand the instructions and warnings in this manual before operating this equipment. Keep this manual in a safe location for future reference.

Inspection

Prior to each use, visually inspect for leaking hydraulic oil, damaged, loose or missing parts. If jack is worn or damaged remove from service and contact your nearest service center for repair.

Maintenance

Check oil level. With the jack in an upright position and the ram completely retracted, open the release valve (turn counter-clockwise) and remove the filter plug. The oil should be just up to the hole. Fill if necessary with clean hydraulic jack oil.

Lubricate internal components. With the release valve open, manually pump the handle six times.

Purge the hydraulic system of air. During transit the unit may become "air-bound", causing a spongy ram action. To purge the system, close the release valve (turn clockwise). Manually pump the jack to full height. Open the release valve and push down on the ram. Repeat these steps if necessary to completely purge the system.

Keep the jack clean. Occasionally lubricate the handle socket pivot point, extension screw, release screw thread, and air valve to prevent corrosion.



AME AIR HYDRAULIC BOTTLE JACKS INSTRUCTION MANUAL

Operation

1. Jack operation is controlled either manually or by external air pressure. Either insert the handle into the handle socket to manually operate or connect to an external air pressure source (clean connections prior to assembly).
2. To raise the jack, turn the release valve clockwise until tight and either manually pump with the provided handle or while connected to an air supply depress the air valve.

! WARNING !
FOR YOUR SAFETY
USE JACK FOR LIFTING ONLY. LOAD MUST BE
SUPPORTED IMMEDIATELY BY OTHER APPROPRIATE MEANS.

3. To lower the jack turn the release valve counter clockwise slightly and very slowly. Be careful not to turn the valve quickly or more than twice, otherwise, dangerous sudden lowering may occur.



AME AIR HYDRAULIC BOTTLE JACKS INSTRUCTION MANUAL

Trouble Shooting

| PROBLEM | CAUSE | SOLUTION |
|---------------------------------------|--|---|
| Air pump will not operate | Low air pressure Air outlet is frozen Lack of oil Other | Keep air pressure between 0.7-1.0 MPA Stop using and thaw frozen outlet Supply oil to air vavle Contact service center |
| Air pump acts but ram won't rise | Release valve is open Lack of hydraulic oil "Air-bound" system Other | Close valve clockwise Supply hydraulic oil See maintanance Contact service center |
| Ram will not rise to highest position | Lack of hydraulic oil Release valve not fully closed | Supply hydraulic oil Close valve clockwise |
| Ram will lower slowly | Outlet valve dirt or defective Air pump packing defective | Contact service center |
| Ram will rise slowly | Filter is full Air pump packing defective Release valve not fully closed | Contact service center |
| Oil blowing from air pump | Air pump packing defective | Contact service center |
| Ram will not lower | Release valve/crcuit defective | Contact service center |

SERVICE: Contact your nearest authorized service center for repairs and/or replacement parts.



AME INTERNATIONAL

2347 Circuit Way, Brooksville, Florida USA 34604

Phone: (+1) 352.799.1111 • Toll Free: (+1) 877.755.4AME (4263)

Fax: (+1) 352.799.1112 • E-mail: sales@ameintl.net



PARTS BREAKDOWN

Parts List For Air Hydraulic Bottle Jack 14460

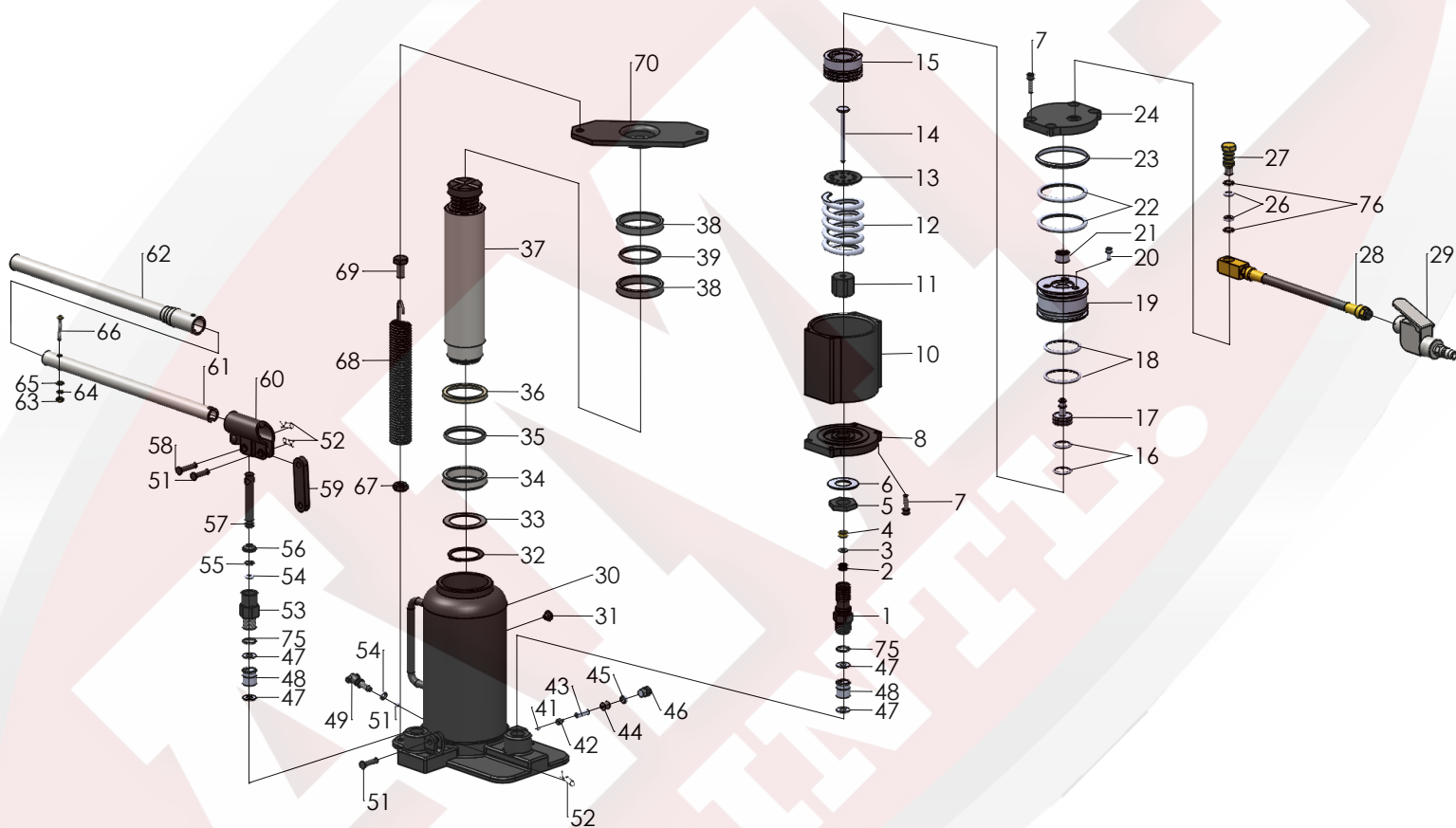



PARTS BREAKDOWN

Parts List For Air Hydraulic Bottle Jack 14460

| ITEM # | DESCRIPTION | Q'TY | ITEM # | DESCRIPTION | Q'TY | ITEM # | DESCRIPTION | Q'TY |
|-----------|-----------------------|------|-----------|------------------------|------|-----------|----------------------------|------|
| 14460-001 | Pump Cylinder | 1 | 14460-031 | Oil Filler Plug * | 1 | 14460-061 | Font Handle | 1 |
| 14460-002 | Y-seal * | 1 | 14460-032 | Snap Ring | 1 | 14460-062 | Rear Handle | 1 |
| 14460-003 | Nylon Gasket * | 1 | 14460-033 | O-ring Retainer | 1 | 14460-063 | Hex Nut | 1 |
| 14460-004 | Copper Washer | 1 | 14460-034 | O-ring * | 1 | 14460-064 | Lock Washer | 1 |
| 14460-005 | Nut | 1 | 14460-035 | Seal Washer | 1 | 14460-065 | Flat Washer | 1 |
| 14460-006 | Butterfly Spring | 1 | 14460-036 | Piston Ring | 1 | 14460-066 | Cross head soket cap screw | 1 |
| 14460-007 | Socket head cap screw | 8 | 14460-037 | Ram Assy | 1 | 14460-067 | Hex Nut (thin) | 2 |
| 14460-008 | Base Cover | 1 | 14460-038 | Bushing | 2 | 14460-068 | Return Spring | 2 |
| 14460-009 | Steel Ball | 4 | 14460-039 | O-ring * | 1 | 14460-069 | Screw | 2 |
| 14460-010 | Air Motor Housing | 1 | 14460-040 | Snap Ring | 1 | 14460-070 | Spring Lid | 1 |
| 14460-011 | Nut | 1 | 14460-041 | Steel Ball | 1 | 14460-071 | Snap Ring | 1 |
| 14460-012 | Spring | 1 | 14460-042 | Safety Vavle Ball Seat | 1 | 14460-072 | Washer | 1 |
| 14460-013 | Washer | 1 | 14460-043 | Safety Vavle Spring | 1 | 14460-073 | Steel Ball | 1 |
| 14460-014 | Air Pump Plunger | 1 | 14460-044 | Safety Valve Adj screw | 1 | 14460-074 | O-ring * | 3 |
| 14460-015 | Air Piston Base | 1 | 14460-045 | O-ring * | 1 | 14460-075 | Nylon Gasket * | 2 |
| 14460-016 | O-ring * | 2 | 14460-046 | Screw | 1 | 14460-076 | Nylon Gasket * | 2 |
| 14460-017 | Air Shuttle Vavle | 1 | 14460-047 | Copper Washer * | 4 | | | |
| 14460-018 | O-ring * | 2 | 14460-048 | Vavle Block Assy | 2 | | | |
| 14460-019 | Air Piston | 1 | 14460-049 | Release Assy | 1 | | | |
| 14460-020 | Socket head cap screw | 3 | 14460-050 | Steel Ball | 1 | | | |
| 14460-021 | Shuttle Valve Seal | 1 | 14460-051 | Link Pin | 2 | | | |
| 14460-022 | O-ring * | 2 | 14460-052 | Pin | 3 | | | |
| 14460-023 | O-ring * | 1 | 14460-053 | Pump Cylinder | 1 | | | |
| 14460-024 | Top Cover | 1 | 14460-054 | O-ring * | 2 | | | |
| 14460-025 | Snap Ring | 1 | 14460-055 | Nylon Gasket * | 1 | | | |
| 14460-026 | O-ring * | 2 | 14460-056 | Dustproof Ring * | 1 | | | |
| 14460-027 | Coupler | 1 | 14460-057 | Pump Plunger | 1 | | | |
| 14460-028 | Air Hose Assy | 1 | 14460-058 | Pump Plunger Pin | 1 | | | |
| 14460-029 | Air Valve Assy | 1 | 14460-059 | Link | 1 | | | |
| 14460-030 | Oil Tank Assy | 1 | 14460-060 | Socket | 1 | | | |

2347 Circuit Way, Brooksville, Florida, USA 34604
 Phone: (+1) 352-799-1111 Toll Phone: (+1) 877-775-4AME (4263)
 Fax: (+1) 352-799-1112 E-mail: sales@ameintl.net www.ameintl.net