

This mini bike has a minimum age requirement of 16 and a maximum weight capacity of 150 lbs. (60 kg). Always wear all necessary and properly fitting protective equipment when operating this mini bike.

**! WARNING:** To reduce the risk of injury, the user must read and understand the operator's manual before using this product.

Obtain, review, and follow provincial/municipal government acts and regulations pertaining to owning and operating an off-road vehicle before using this product.

## SAVE THIS MANUAL FOR FUTURE REFERENCE

El requisito para usar este mini motocicleta es que el usuario tenga, como mínimo, 16 años. La capacidad de peso máxima de este motocicleta mini es de 60 kg (150 lb). Use siempre todo el equipo de protección que sea necesario y que calce correctamente al operar este motocicleta mini.

**! ADVERTENCIA:** Para reducir el riesgo de lesiones, el usuario debe leer y comprender el manual del operador antes de usar este producto.

Obtenga, revise y obedezca todas las leyes y reglamentaciones gubernamentales provinciales y municipales relacionadas con la tenencia y la operación de un vehículo todoterreno antes de usar este producto.

## GUARDE ESTE MANUAL PARA FUTURAS CONSULTAS

# TABLE OF CONTENTS

■ Limited Warranty.....	2
■ Rules for Safe Operation .....	3
■ Symbols.....	4
■ Safety Labels.....	5-6
■ Features .....	7-8
■ Operation.....	9-11
■ Maintenance.....	12-19
■ Troubleshooting.....	20
■ Emissions Warranty.....	21
■ Product Specifications.....	22

## LIMITED WARRANTY

**KEEP YOUR RECEIPT.** Proof of purchase will be required to substantiate any warranty claim.

**WHAT IS COVERED:** Baja, Inc. warrants to the original retail purchaser in the United States of America, or Canada that this product is free of defects in material and workmanship and agrees, at Baja, Inc's discretion, to either repair, provide replacement parts for, or replace (without charge for parts or labor) any product or component with a material defect for a period of 6 months from the date of purchase, except as limited below. Warranty service and replacement parts are warranted only for the duration of the warranty on the original product. All replaced parts and products become the property of Baja, Inc. This product is also covered by an Emissions Control System Warranty which is separate from and in addition to this warranty.

**WHAT IS NOT COVERED:** This warranty does not cover any conditions caused by misuse, neglect, negligence, accident operation in any way contrary to the operating instructions in the operator's manual, normal wear, alteration, modification, improper or inadequate maintenance, use of unauthorized replacement parts, or service provided by anyone other than an Authorized Baja Motorsports® Service Center. This warranty does not cover transportation costs for warranty service. Without limiting the above, this warranty is VOID with respect to any product that has been used for rental or commercial purposes or that sustained the following damage:

- Bent or broken frame due to abuse
- Bent or broken wheel or wheels due to abuse
- Bent or broken fender due to abuse
- Any sign of impact, accident, jumping, spin-outs or roll over not caused by the condition for which the warranty coverage is sought.

**TO GET SERVICE:** Contact Baja, Inc. toll free at 888-863-2252 Monday through Friday between the hours of 7AM and 4 PM, Mountain Time (MST). A copy of the sales receipt will be required as proof of purchase. Any approved warranty service will be referred to an Authorized Baja Motorsports® Service Center. The cost of transporting the product to and from the service center must be paid by the owner.

**BAJA, INC'S OBLIGATION UNDER THIS WARRANTY IS STRICTLY AND EXCLUSIVELY LIMITED TO THE REPAIR OR REPLACEMENT OF DEFECTIVE PARTS AND BAJA, INC. DOES NOT ASSUME OR AUTHORIZE ANYONE TO ASSUME FOR THEM ANY OTHER OBLIGATION. NO DEALER IS AUTHORIZED TO MODIFY THIS WARRANTY.**

**ALL IMPLIED WARRANTIES ARE LIMITED IN DURATION TO THE STATED WARRANTY PERIOD, AND ARE HEREBY EXPRESSLY DISCLAIMED IN THEIR ENTIRETY AFTER THE EXPIRATION OF THE STATED 6 MONTH WARRANTY PERIOD. SOME STATES DO NOT ALLOW LIMITATIONS ON HOW LONG AN IMPLIED WARRANTY LASTS, SO THE ABOVE LIMITATION MAY NOT APPLY TO YOU. BAJA, INC. ASSUMES NO RESPONSIBILITY FOR INCIDENTAL, CONSEQUENTIAL OR OTHER DAMAGES. SOME STATES DO NOT ALLOW THE EXCLUSION OR LIMITATION OF INCIDENTAL OR CONSEQUENTIAL DAMAGES, SO THE ABOVE LIMITATION OR EXCLUSION MAY NOT APPLY TO YOU.**

This warranty gives you specific legal rights, and you may also have other rights which vary from state to state.

### **WARNING:**

This manual should be considered as a permanent part of the vehicle and should remain with the vehicle when resold or otherwise transferred to a new user or operator. The manual contains important safety information and instructions which should be read carefully before operating the vehicle. All operators should obtain, review, and follow provincial and municipal government acts and regulations pertaining to owning and operating an off-road vehicle. Children under the age of 16 should never operate this vehicle.

# RULES FOR SAFE OPERATION

## **WARNING:**

This operator's manual contains important safety and maintenance information. Read it carefully and make sure you understand all included information before riding. Failing to follow the warnings contained in this manual could result in **SERIOUS INJURY** or **DEATH**.

## **NOTICE TO PARENTS**

This mini bike is built for use by persons age 16 and older. Never allow anyone under the age of 16 to operate the mini bike.

It is very important that every person who rides the mini bike complete a training course.

## **READ ALL INSTRUCTIONS**

It is important that this manual remain with the vehicle when you transfer or loan it to another user or owner.

All information, illustrations, photographs and specifications contained in this manual are based on the latest product information available at the time of publication. Due to improvements or other changes, there may be some discrepancies in this manual. We reserve the right to make product changes at any time, without notice and without incurring any obligation to make the same or similar changes to the vehicle previously built or sold.



- Carefully read and understand this manual and all labels and follow the operating procedures described.
- Never operate a mini bike without proper instruction. Take a training course. Beginners should receive training from a certified instructor. Contact an authorized mini bike dealer or call Motorcycle Safety Foundation at 1-800-446-9227 to find out about the training courses nearest you.
- Never carry a passenger on a mini bike.
- Do not operate the engine in a confined space where dangerous carbon monoxide fumes can collect. Carbon monoxide, a colorless, odorless, and extremely dangerous gas, can cause unconsciousness or death.
- Never consume drugs or alcohol before or while operating this mini bike.
- Never operate a mini bike on any paved surfaces, including sidewalks, driveways, parking lots, and streets.
- Never operate a mini bike on any public street, road, or highway, even a dirt or gravel one.
- Never operate the mini bike at night. Night is defined as the period of time 30 minutes before sunset to 30 minutes after sunrise.

- Never operate a mini bike without wearing a DOT or Snell-approved motorcycle helmet that fits properly. You should also wear eye protection (goggles) marked to comply with ANSI Z87.1, gloves, over the ankle boots, long-sleeved shirt or jacket, and long pants.
- Never operate this mini bike at excessive speeds. Always ride at a speed that is proper for the terrain, visibility, operating conditions, and your experience.
- Always keep both hands on the handlebars and both feet on the footrests of the mini bike during operation.
- Always be careful when skidding or sliding. Learn to safely control skidding or sliding by practicing at low speeds and on level, smooth terrain. On extremely slippery surfaces such as ice, go slowly and be very cautious in order to reduce the chance of skidding or sliding out of control.
- Never operate the mini bike on hills too steep for the mini bike or for your abilities. Practice on smaller hills before attempting larger hills.
- Check the terrain carefully before you start up any hill. Never climb hills with excessively slippery or loose surfaces. Shift your weight forward. Never open the throttle suddenly. Never go over the top of any hill at high speed.
- Never attempt wheelies, jumps, or other stunts.
- Never operate a mini bike in water.
- Always inspect your mini bike each time you use it to make sure it is in safe operating condition. Always follow the inspection and maintenance procedures and schedules described in this manual.
- Never modify a mini bike through improper installation or use of accessories.
- Always use the size and type tires specified in this manual. Always maintain proper tire pressure as described in this manual.
- Check the terrain carefully before you start down any hill. Shift your weight backward. Never go down a hill at high speed.
- Never exceed the stated load capacity of 150 lbs. (68 kg).
- Never ride alone. This mini bike can go 15 miles (24.1 km) in an hour, which may be farther than you can walk back in the event of a problem with the mini bike.
- We believe in conservation and protection of the earth's natural resources. We encourage every vehicle owner and operator to do the same by obeying posted signs and riding only in areas designated and approved for off-road recreational use.









**FOR MORE INFORMATION ABOUT MINI BIKE SAFETY,  
CALL BAJA MOTORSPORTS AT 1-866-260-8630.**

# SYMBOLS

The following signal words and meanings are intended to explain the levels of risk associated with this product.

SYMBOL	SIGNAL	MEANING
	<b>DANGER:</b>	Indicates an imminently hazardous situation, which, if not avoided, will result in death or serious injury.
	<b>WARNING:</b>	Indicates a potentially hazardous situation, which, if not avoided, could result in death or serious injury.
	<b>CAUTION:</b>	Indicates a potentially hazardous situation, which, if not avoided, may result in minor or moderate injury.
	<b>CAUTION:</b>	(Without Safety Alert Symbol) Indicates a situation that may result in property damage.

Some of the following symbols may be used on this product. Please study them and learn their meaning for safe operation of this product.

SYMBOL	NAME	EXPLANATION
	Safety Alert	Indicates a potential personal injury hazard.
	Read Operator's Manual	To reduce the risk of injury, user must read and understand operator's manual before using this product.
	Wear Eye Protection	Always wear eye protection with side shields (goggles) marked to comply with ANSI Z87.1.
	Wear Protective Gear	Always use an approved helmet and protective gear.
	Public Roads	Never use this mini bike on public roads.
	Passengers	Never carry passengers on this mini bike.
	Drugs and Alcohol	Never use with drugs or alcohol.
	Age Limit	Never permit children under the age of 16 to operate this mini bike.
	Toxic Fumes	Gas products emit carbon monoxide, an odorless, colorless, poison gas. Breathing carbon monoxide can cause nausea, fainting, or death.

# SAFETY LABELS

The following labels are found on the product. For your safety, please review and understand all of the labels before starting the product. If any of the labels come off the unit or become hard to read, contact an authorized service center for replacement.

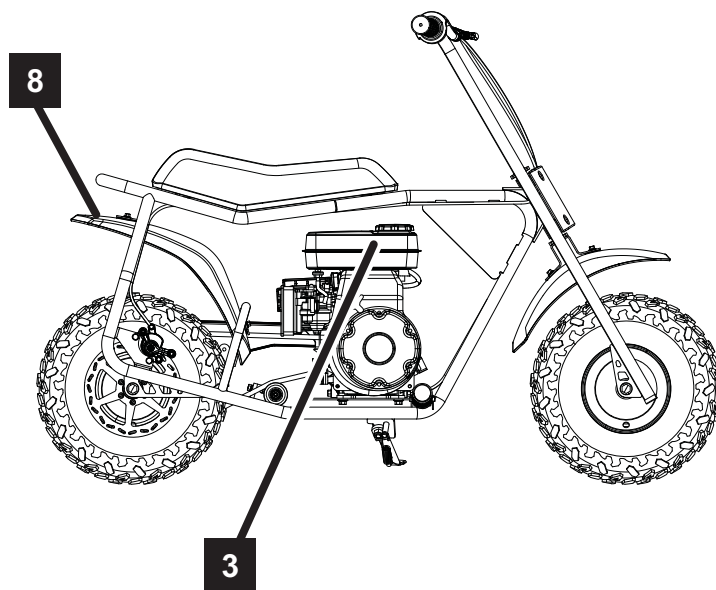
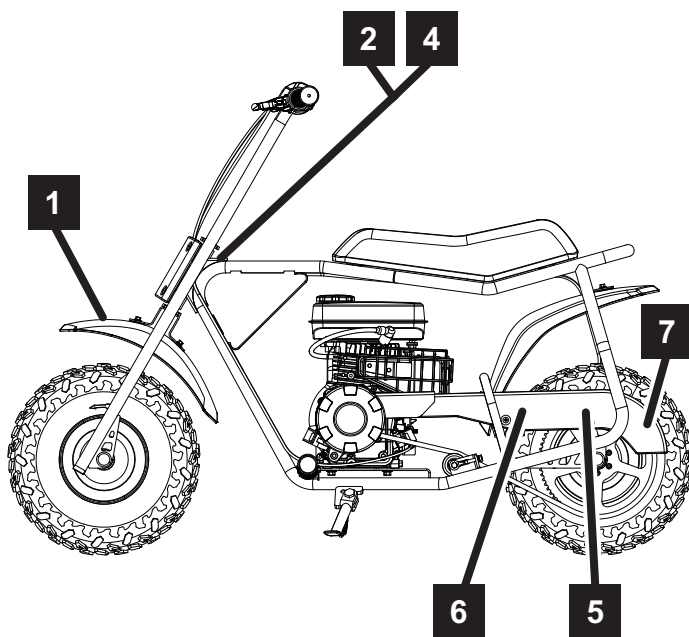

**1**

**⚠ WARNING**

Improper use of this OFF-ROAD MOTORCYCLE can result in SEVERE INJURY or DEATH

Always use an approved helmet and protective gear

Never use on public roads

Never carry passengers

Never use with drugs or alcohol

**NEVER** operate:

- without proper training or instruction.
- at speeds too fast for your skills or the conditions.
- on public roads—a collision can occur with another vehicle.
- with a passenger—passengers affect balance and steering and increase risk of losing control.

The operator must **ALWAYS**:

- use proper riding techniques to avoid vehicle overturns on hills and rough terrain and in turns.
- avoid paved surfaces—pavement may seriously affect handling and control.
- be seated with kickstand up before starting the engine.

**LOCATE AND READ OPERATOR'S MANUAL  
FOLLOW ALL INSTRUCTIONS AND WARNINGS**

989000166-01

**2**

**3**

**⚠ DANGER**

Risk of Fire. Check for any fuel overflow or leaking. Stop the engine before refueling.

Fuel and its vapors are extremely flammable and explosive. Fire can cause severe burns or death.

**4**

**⚠ WARNING**

**This vehicle is an off-road motorcycle and is not intended for use on public highways.**

989000171-01

# SAFETY LABELS

5

**⚠ WARNING**



Operating this vehicle if you are under the age of 16 increases your chance of severe injury or death.

**NEVER permit children under age 16 to operate this vehicle.**

989000168-01

6

**⚠ WARNING**

- Improper tire pressure or overloading can cause loss of control. Loss of control can result in severe injury or death.
- Check pressures on all tires only when tires are cold.

**COLD TIRE PRESSURE:** Recommended: **5 psi (34.5 kpa)**

**LOADING:** Maximum vehicle capacity is: **150 lbs (68 kg)**  
Maximum capacity includes the weight of the operator, cargo, and accessories.

7

**⚠ WARNING**



- Moving parts can crush and cut.
- Keep hands clear.
- Do not operate with guard removed.

8

**For customer service call/  
Pour service à la clientèle téléphoner /  
Para servicio al cliente llame**

**1-888-863-BAJA**  
(2252)

## VEHICLE IDENTIFICATION NUMBER (VIN) AND ENGINE SERIAL NUMBER LOCATION

You need to know the VIN and engine serial numbers to get title documents for the mini bike. You also need these numbers to order parts from your authorized service center or Baja Motorsports.

From a seated position on the mini bike, the VIN is stamped on the right side of the frame neck where the steering attaches. The engine serial number is located on the left side of the engine housing.

Write down the serial numbers here for your future reference:

**VIN:**

**Engine No:**

# FEATURES

**Brake lever** — The brake can be applied by squeezing the brake lever.

**Engine switch** — The engine switch must be placed in the ON position to start the engine. To stop the engine, place the switch in the OFF position.

**Fuel valve** — This vehicle has one manually operated fuel valve featuring 2 positions.

In the ON position, fuel is allowed to flow into the carburetor when the engine is running or being started.

In the OFF position, fuel is shut off from the carburetor. The fuel valve needs to be placed in this position when the mini bike is not in use.

**Fuel tank cap** — To open the fuel tank cap, turn the cap counterclockwise. To close, turn the cap clockwise and tighten it securely.

**Manual choke lever** — When engine is cold, place the choke lever in the ON position. When engine has warmed up, move lever back to the OFF position.

**Pull cord** — Pull the pull cord to start the engine.

**Throttle grip** — Controls engine and mini bike speed. Rotate the throttle grip backward (toward operator) to increase engine and mini bike speed. Rotate the throttle grip forward (away from operator) to decrease engine and mini bike speed.

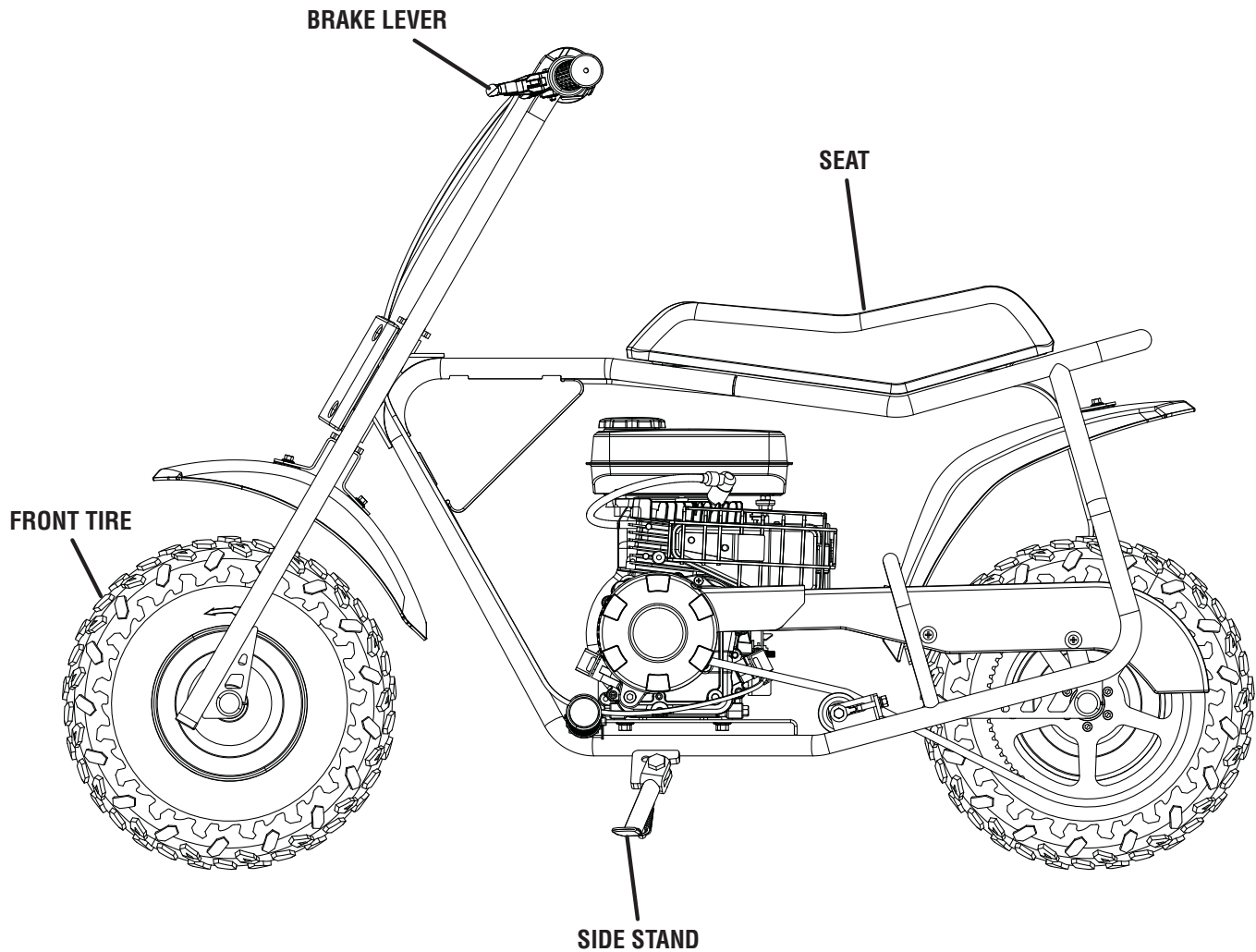

# FEATURES

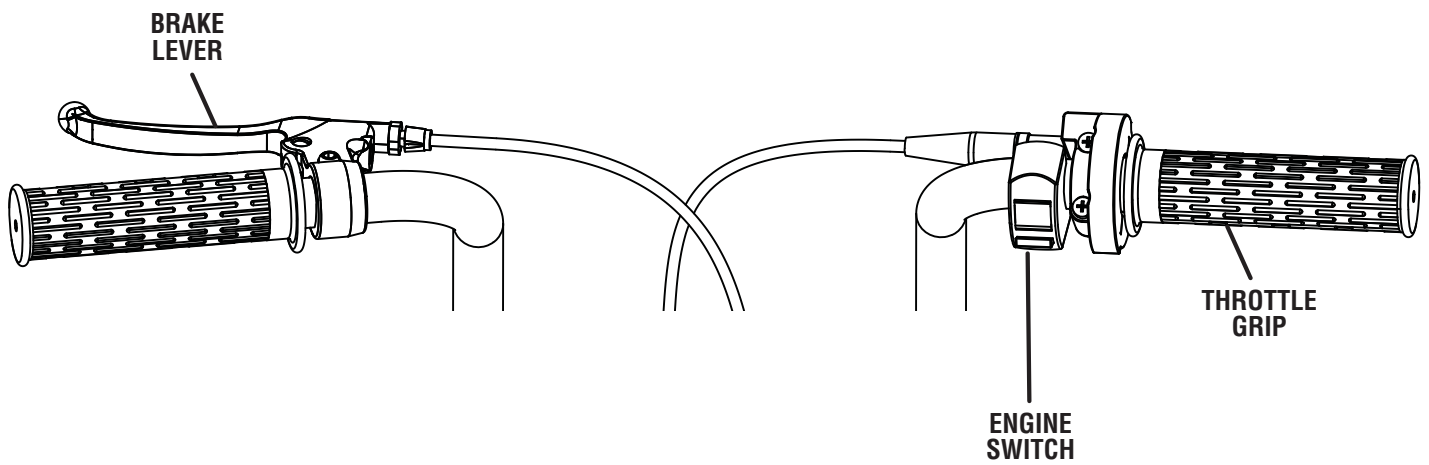
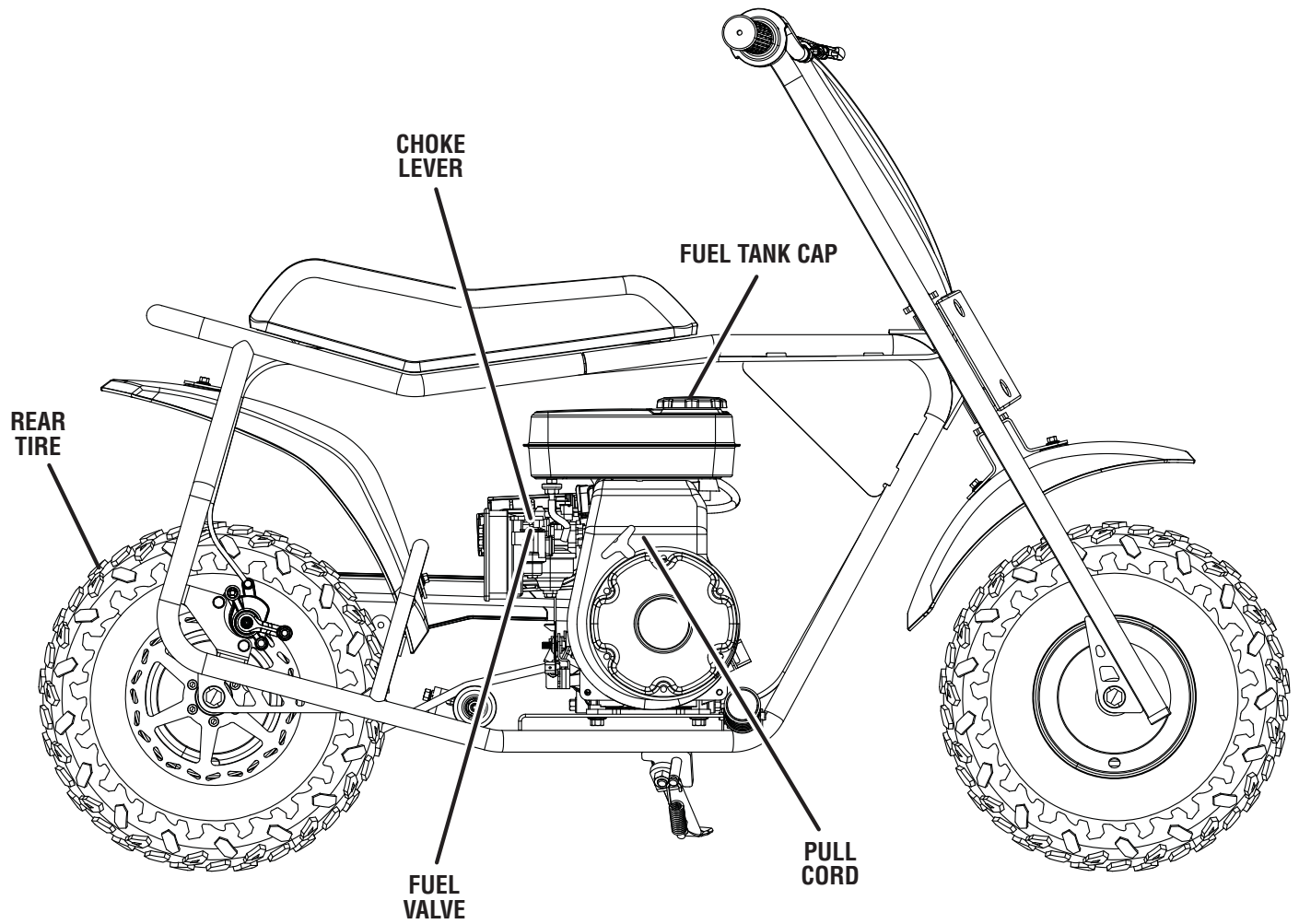

# OPERATION

## **WARNING:**

Always wear appropriate protective clothing and accessories: a properly fitting helmet, eye protection (goggles) marked to comply with ANSI Z87.1, gloves, over the ankle boots, long-sleeved shirt or jacket, chest protector, and long pants.

## **WARNING:**

Always wear eye protection with side shields (goggles) marked to comply with ANSI Z87.1. Failure to do so could result in objects being thrown into your eyes, resulting in possible serious injury.

## **WARNING:**

Do not allow familiarity with product to make you careless. Remember that a careless fraction of a second is sufficient to inflict serious injury.

## SAFETY GEAR

A DOT or Snell-approved motorcycle helmet is the most important part of your safety gear because it can help prevent a serious head injury. Choose a helmet that fits snugly. Retailers can help in selecting a good quality helmet which fits properly.

Always wear eye protection when you ride. If a rock or branch hit your eyes, you could be severely injured. Wear shatterproof goggles that are marked to comply with ANSI Z87.1.

## BREAK-IN

### CAUTION:

Carefully and correctly follow the break-in procedures. Failure to follow the break-in procedures can significantly shorten the life of your mini bike by causing excessive wear and damaging the engine.

The first month is the most important in the life of your vehicle. Proper operating during this break-in period will be helpful for assuring maximum life and performance of your new mini bike. The following guidelines explain proper break-in procedures.

**Vary the engine rotating speed.** Vary the engine rotating speed during the break-in period. This allows the parts to “load” and then “unload” (allowing the parts to cool). Although it is essential to place some stress on the engine components during break-in, you must be careful not to load the engine too much.

**Avoid constant low or high rotating speed.** Operating the engine at constant low rotating speed (light load) can cause parts to glaze and not seal properly. Operating the engine at a constant high rotating speed can cause excessive heat, which can damage internal components. Allow the engine

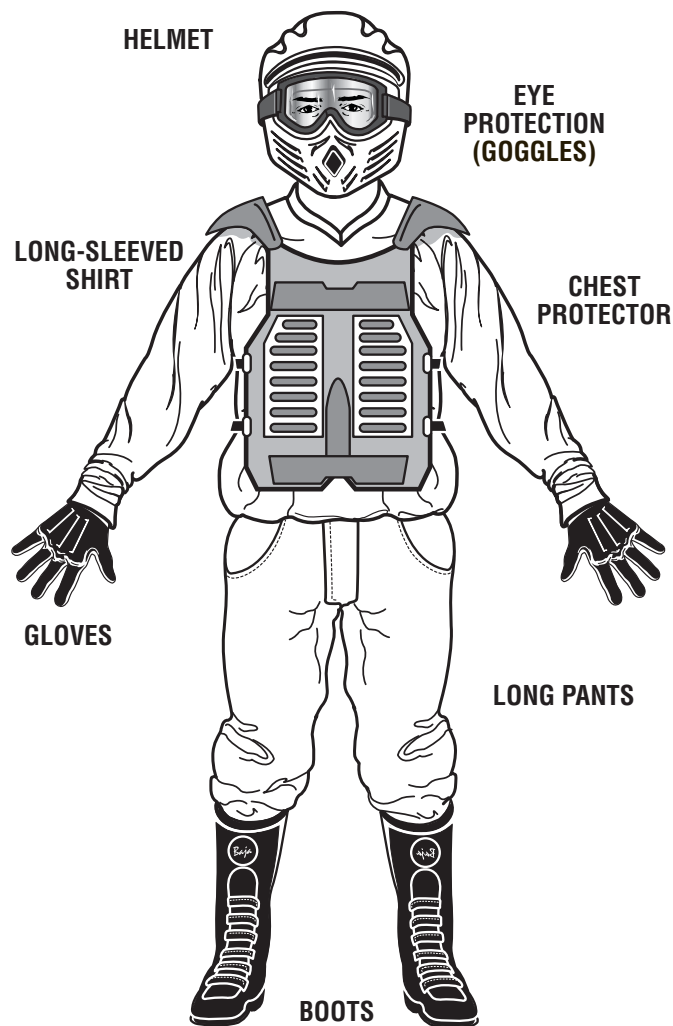

to accelerate freely without exceeding the maximum throttle limit.

**Allow the engine lubricant to circulate before riding.** Allow enough idling time after warm or cold engine starting. This allows the lubricant to reach all critical engine components.

**Observe and document your initial and most critical service.** The initial service (break-in maintenance) is the most important service that your vehicle will receive. Observing a proper break-in operating, will help engine components seal properly. Maintenance required as part of the initial service includes proper adjustments, tightening of all bolts and nuts, and replacement of dirty oil. Timely performance of this service will help you get the best service life and performance of the engine.

## **WARNING:**

Always inspect your mini bike according to the pre-ride inspection checklist each time before riding and make sure it is in a safe operating condition. Failure to inspect the mini bike before operating could increase the chance of an accident, resulting in serious personal injury or equipment damage.

# OPERATION

## **⚠ WARNING:**

Always use the size and type of tires specified in this Operator's Manual. Always maintain proper tire pressure as described in the *Maintenance* section of this manual and on the unit. Operating this mini bike with improper tires, or improper tire air pressure, could be hazardous. If you use improper tires or improper air pressure, you may lose control of the mini bike and cause an accident, which could result in serious personal injury.

## WHAT YOU SHOULD KNOW BEFORE RIDING

Before riding, you should read carefully and understand all the following information, in addition to being thoroughly familiar with the *Rules for Safe Operation* in the front of this manual. If you are properly prepared, you will have a more enjoyable ride.

Before riding, you should find a flat, open area with enough space to practice the skills.

## **⚠ WARNING:**

The risk of an accident is greatly increased if the operator does not know how to operate the mini bike properly in different situations and on different types of terrain. Beginning and inexperienced operators should complete the certified training courses offered by the Motorcycle Safety Foundation ([www.msf-usa.org](http://www.msf-usa.org)). They should then regularly practice the skills learned in the course and the operating techniques described in the Operator's Manual. Failure to follow safe and proper operating techniques could result in serious personal injury.

For more information about the training course, contact an authorized mini bike dealer or call the Motorcycle Safety Foundation at 1-800-446-9227. For more information on mini bike safety, contact the Baja Mini Bike Safety Hotline at: 1-866-260-8630.

Do not operate the mini bike indoors where there is little or no ventilation. Breathing in exhaust gasses from the mini bike could cause severe injury or death. Always run your mini bike outdoors where there is fresh air.

Make sure it is legal to ride in the area you selected; comply with all laws and make sure you are not trespassing. Call the police if you don't know where you can ride.

Protect your riding areas. When you are riding, remember to keep the terrain in good condition. Don't destroy plants, trees, or other vegetation. Don't litter and don't bother wildlife. With your help, your riding area can remain open for use in the future.

After you have found a good place to practice, review the control system on your mini bike before riding. Learn to find these controls without looking for them, because you will not have time to look for them when you are riding.

**NOTE:** Obtain, review, and follow all laws, acts, and regulations pertaining to owning and operating an off-road vehicle.

## **⚠ WARNING:**

Never ride your mini bike on a frozen lake or river. Serious injury or death could occur if the ice breaks.

## FUELING/REFUELING THE MINI BIKE

### **⚠ WARNING:**

Gasoline and its vapors are highly flammable and explosive. To prevent serious personal injury and property damage, handle it with care. Keep away from ignition sources and open flames, handle outdoors only, do not smoke, and wipe up spills immediately.

### **⚠ WARNING:**

Improper fueling of the mini bike could be hazardous. Failing to follow safety precautions when refueling could result in a fire or explosion or let you breathe toxic fumes, causing serious personal injury.

### **⚠ WARNING:**

Always shut off engine before fueling. Never add fuel to a mini bike with a running or hot engine. Do not smoke or allow flame or spark in the vicinity while the unit is being refueled. Always work in a well-ventilated area. Move at least 30 ft. (9,1 m) from refueling site before starting engine. Improper handling of fuel could result in serious personal injury.

- Clean surface around fuel cap to prevent contamination.
- Slowly turn the fuel tank cap counterclockwise and remove.

### **⚠ WARNING:**

If a whistling sound is heard when loosening the fuel tank cap, have the vehicle inspected and repaired before continued operation. Failure to do so could cause the fuel to overheat, resulting in a fire or explosion causing serious personal injury.

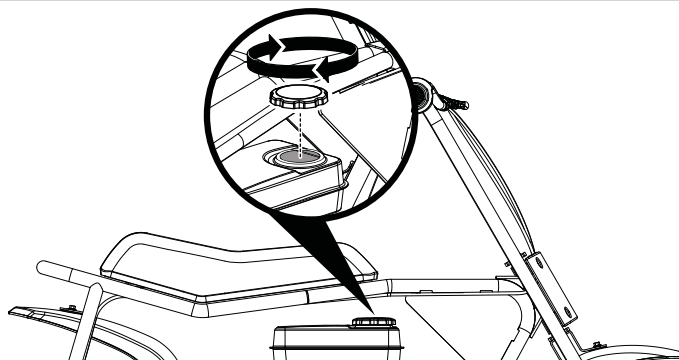

# OPERATION

- Carefully pour fuel into the tank until the level reaches approximately 2 in. below the top of the fuel tank opening. Avoid spillage.
- Replace fuel tank cap and turn clockwise to secure.

## WARNING:

Check for fuel leaks. A leaking fuel cap is a fire hazard and must be replaced with an original manufacturer's replacement cap immediately. If you find any leaks, correct the problem before using the product. Failure to do so could result in a fire that could cause serious personal injury.

## WARNING:

Overfilling the fuel tank could be hazardous. If you overfill the fuel tank, fuel may overflow when it expands due to heat from engine or sun. Spilled fuel could catch fire or explode, resulting in serious personal injury.

## WARNING:

Failure to complete the pre-ride inspection and verify proper performance of the mini bike before riding can result in serious personal injury.

## PRE-RIDE INSPECTION

ITEM TO CHECK	ITEM MUST PERFORM AS FOLLOWS:
Steering	Smoothness; no restriction of movement; no play or looseness.
Brakes	Proper brake lever free play; enough brake force.
Tires	Proper air pressure; enough tread depth; no cracks, rips, or other damages.
Fuel	Enough fuel for the intended trip.
Fuel cap	No damage to fuel tank or cap; fuel tank cap closed securely.
Engine stop switch	Proper operation of switch. Start engine, then press stop switch. Engine should stop.
Engine lubricant	Proper level; check lubricant by inspecting engine oil dip stick. The engine lubricant should be between the minimum and maximum lines.
Throttle	Proper free play of throttle grip; smooth response; quick return to idle position.
General condition	Bolts and nuts are tight; no rattle from any parts of the engine when running; no visible evidence of damage including frame cracks.

## STARTING THE ENGINE

- Place the engine switch in the ON position.
- Turn the fuel valve to the ON position.
- Place the choke lever in the ON position.
- Pull the pull cord sharply until the engine runs. Return the cord gently to the unit. Do not allow it to snap back.
- Allow engine to warm, then move the choke lever to the OFF position.

**NOTE:** The engine may run best with the choke lever between the ON and OFF positions.

## WARNING:

Always open the throttle gradually when you want to accelerate. Opening the throttle suddenly could cause the front wheel to leave the ground and cause loss of control of the mini bike causing serious personal injury.

## WARNING:

Always keep both hands on the handlebars and both feet on the foot rests of your mini bike during operation. Removing even one hand or foot can reduce your ability to control the mini bike or could cause you to lose your balance and fall off the mini bike. If you remove a foot from the footrest, you may come in contact with the mini bike, ground, obstacles, etc., which could cause an accident and result in serious personal injury.

## STOPPING THE ENGINE

- Rotate the throttle grip forward (away from you) to slow down the engine.
- Place the engine switch in the OFF position.
- Place the choke lever in the OFF position.
- Turn the fuel valve to the OFF position.

# MAINTENANCE

## INSPECTION AND MAINTENANCE SCHEDULE

It is very important to inspect and maintain your mini bike regularly. Follow the guidelines in the chart below. The intervals between periodic services in months are shown. At the end of each interval, be sure to perform and document the maintenance listed.

Only an authorized Baja service center may maintain, replace, or repair emission control devices and systems.

### WARNING:

Failing to perform recommended maintenance or performing maintenance improperly can lead to an accident and cause serious personal injury, cause noncompliance to emissions regulations, and may void your warranty. If you are not sure how to perform the maintenance items below, contact your Baja authorized service center or Baja Motorsports.

Item	Each Use	First month or 20 hours	Every 3 months or 50 hours	Every 6 months or 100 hours	Every year or 300 hours
Engine Oil – Check	X				
Engine Oil – Change*		X		X	
Air Filter – Check	X				
Air Filter – Clean*			X	X	
Air Filter – Change*					X
Carburetor Sediment Cup – Clean*			X		
Spark Plug – Check, Adjust				X	
Spark Plug – Replace					X
Idle Speed – Check, Adjust					X
Valve Clearance – Check, Adjust**					X
Fuel Tank and Filter – Clean					X
Fuel Tube – Check					X
Centrifugal Clutch – Clean and Lube	X Every 5 hours				
Nuts and Bolts – Check for Tightness	X				
Chain Tension – Check	X				
Brakes – Check*	X				
Throttle – Check*	X				
Throttle Cable – Check*	X				

\* – This item of maintenance should be carried out at a service center. It may also be done by the user with reference to this manual provided special tools and authorized spare parts are used. The user must also be capable of completing the procedure.

\*\* – In order to ensure safety, this item may only be carried out by an authorized service center.

### CAUTION:

If you operate your mini bike under severe conditions, it will need maintenance more often than shown in the chart above. Severe conditions include operating under frequent full throttle or in dusty, wet, sandy, or muddy areas. If you have questions regarding appropriate maintenance intervals for your mini bike, contact your Baja authorized service center or Baja Motorsports.

# MAINTENANCE

## ⚠ WARNING:

Before inspecting, cleaning, or servicing the mini bike, shut off engine, wait for all moving parts to stop, ensure engine switch is in OFF position and disconnect the spark plug wire. Failure to follow these instructions can result in serious personal injury or property damage.

## SPARK PLUG

Your mini bike is equipped with an NGK BP7HS spark plug. To determine if the standard spark plug is in good condition, check the color of the plug's center electrode insulator after vehicle operation. A brown color indicates that the plug is correct. A white or dark insulator indicates that the engine may need adjustment or another plug type may be needed. Consult your authorized dealer or Baja Motorsports if your plug insulator is not a light brown color.

**NOTE:** This mini bike uses a resistor-type spark plug to avoid jamming electronic parts. Improper spark plug selection may cause electronic interference with your mini bike's ignition system, resulting in the vehicle performance problems. It could also have an incorrect fit or heat range for your engine, which could cause severe engine damage and void the warranty. Use only recommended spark plugs: NGK BP7HS or suitable equivalent.

To install a spark plug, turn it in as far as possible with your fingers, then tighten it with a wrench about 1/2 turn past finger tight (if the spark plug is new) or 1/4 turn past finger tight (if you are reinstalling the old spark plug). Be careful not to cross-thread the spark plug, which could damage the aluminum threads of the cylinder head.

To maintain a proper functioning spark plug, keep the plug free of carbon. Remove carbon from the plug with a wire or pin and adjust the gap to 0.028-0.031 in. (0.7-0.8 mm) for good ignition. Use a thickness gauge to check the gap.

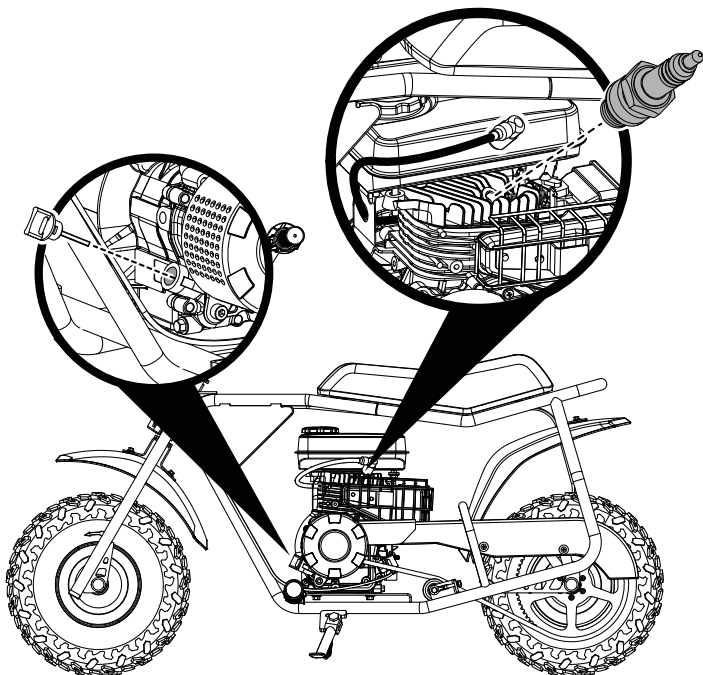

## CAUTION:

Keep the spark plug hole covered while the spark plug is removed so that dirt does not enter the open hole. Dirt entering the spark plug hole in the cylinder could damage engine parts that move.

## CHANGING/ADDING ENGINE LUBRICANT

Engine lubricant has a major influence on engine performance and service life. Engine lubricant level should be checked before each use of the mini bike.

For best engine performance, change the lubricant every 20 to 40 hours of operation. In dirty and dusty areas, the lubricant should be changed more often.

Reference the chart below for the appropriate engine lubricant to use based on the temperature range in your area.

**NOTE:** In very cold weather [below 5°F (15°C)], use SAE10W-50 for good starting and smooth operation.

ENGINE LUBRICANT	SAE 10W-30							
	SAE 20W-40				SAE 10W-50			
	SAE 15W-40							
TEMP. °C	-30	-20	-10	0	10	20	30	40
TEMP. °F	-22	-4	14	32	50	68	86	104

Always use a 4-stroke motor lubricant that meets or exceeds the requirements for API service classification SJ. Check lubricant level before each use.

**NOTE:** Non-detergent or 2-stroke engine lubricants will damage the engine and should not be used.

### To check lubricant level:

- Park vehicle on level ground and lower side stand.
- Unscrew the oil cap/dipstick and remove.
- Wipe dipstick clean and re-seat in hole, but do not re-thread.
- Remove the dipstick and inspect the lubricant level. Level should be between the minimum and maximum marks on the dipstick.
- If lubricant is below minimum mark on dipstick, add lubricant until level falls between minimum and maximum marks on the dipstick.

# MAINTENANCE

## To change engine lubricant:

Lubricant should be changed while the engine lubricant is still warm, but not hot. This allows the lubricant to drain quickly and completely.

- Park vehicle on level ground and lower side stand.
- Remove oil cap/dipstick.
- Place a container underneath the oil drainage bolt to collect used lubricant as it drains.
- Unscrew the oil drainage bolt and remove the bolt and washer.
- Allow lubricant to drain completely.

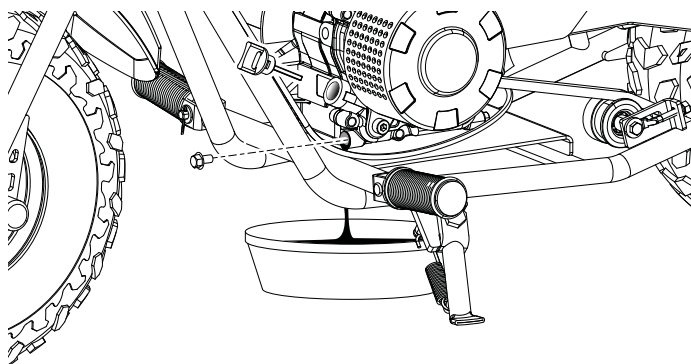

- Reinstall washer and oil drainage bolt. Torque oil drainage bolt to 18 ft.lbs. (24 Nm).
- Fill crankcase with specified lubricant as described in the Operator's Manual.

**NOTE:** Used lubricant should be disposed of at an approved disposal site. See your local oil retailer for more information.

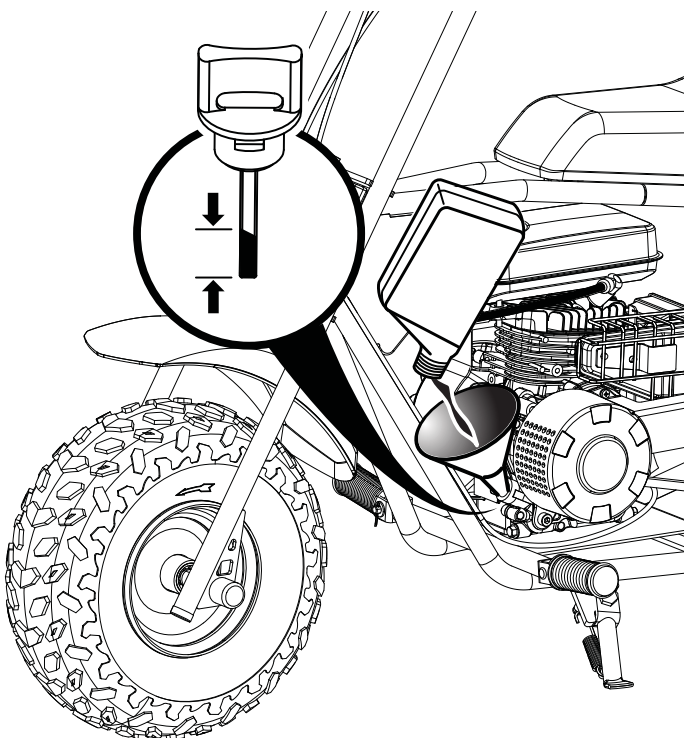

## CHECKING/CLEANING AIR FILTER

The air filter element must be kept clean to provide good engine power. If you use your vehicle under normal, low-tension conditions, you should service the air filter at the intervals specified. If you ride in dusty, wet, or muddy conditions, you will need to inspect the air filter element much more frequently.

### CAUTION:

Always check the air filter element after riding in severe conditions and clean or replace as needed. Operating the mini bike with a clogged air filter could cause engine damage.

### Air filter removal and cleaning:

- Remove the Phillips head screw and set aside.
- Remove the air filter cover and set aside.
- Remove the air filter from the box.
- Wash the element in a mild non-flammable solvent.
- Squeeze out solvent by pressing the element between the palms of both hands. Do not twist or wring the element or it will develop cracks.
- Immerse the element in oil, then squeeze as before to remove excess. The element should be damp with oil but not soaked.
- Replace the air filter element in the box. Make sure the element is securely in position and the air filter is properly sealed.
- Replace the air filter cover. Reinstall screw and tighten securely.

**NOTE:** Do not operate the engine without the air filter elements in place. Rapid engine wear will result.

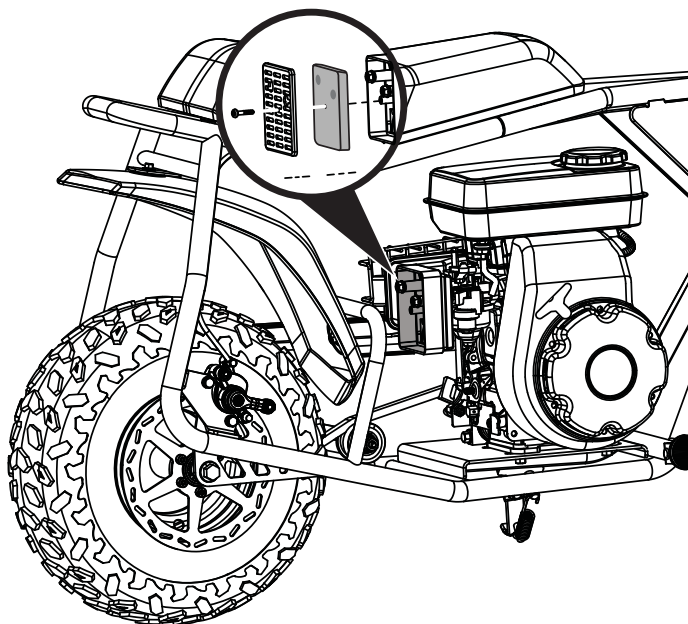

# MAINTENANCE

## THROTTLE GRIP ADJUSTMENT

Inadequate throttle grip free distance could cause the engine speed to rise suddenly when you turn the handlebars. The correct throttle grip free play distance is between 0.078 in. (2 mm) and 0.24 in. (6 mm). If more or less movement is present, adjust the throttle grip as follows:

- Pull back the rubber boot to gain access to the adjustment nut.
- Rotate the adjustment nut in or out to obtain the correct play.
- Recheck the throttle grip free distance. Readjust if it is still not within the correct limits.

### **⚠ WARNING:**

Do not operate the mini bike if the throttle grip free play distance is less than 0.078 in. (2 mm) or more than 0.24 in. (6 mm). Operating the vehicle with an incorrect amount of throttle grip free play could cause the rider to lose control, resulting in serious personal injury.

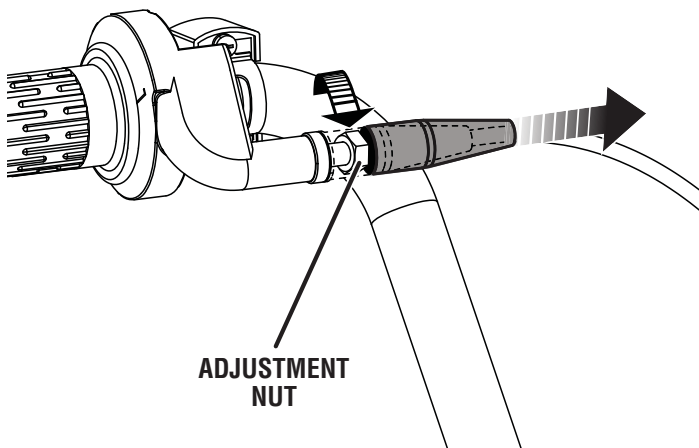

## IDLE SPEED ADJUSTMENT

Excessive engine wear can result when the idle speed is incorrect. An idle speed that is too high could also cause the mini bike to lurch forward when you start the engine.

**NOTE:** You must have a tachometer to adjust the idle speed. If you don't have one, have this service performed by an authorized service center.

### **To adjust idle speed:**

- Start the engine and allow it to warm up.
- Turn the engine idle screw in or out until the engine idle speed is between 1,350 and 1,650 r/min. on the tachometer.

### **CAUTION:**

Make sure the engine is fully warm before adjusting the idle speed. Adjusting the idle speed before the engine is warm could result in excessive engine wear.

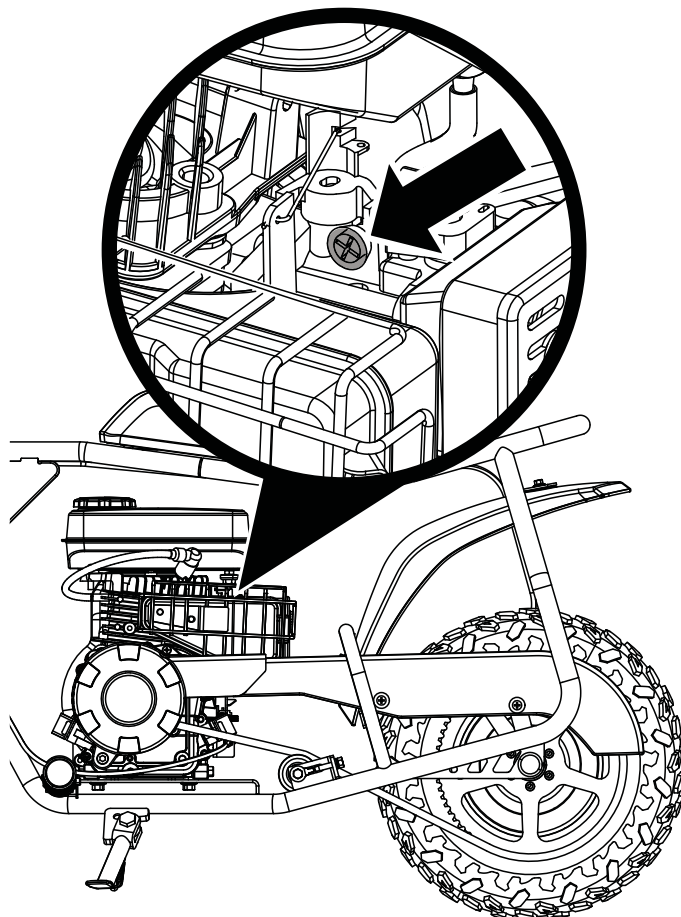

# MAINTENANCE

## **⚠ WARNING:**

Failure to adjust the brakes so they lock the wheels securely could result in serious personal injury.

## ADJUSTING BRAKE

- Measure the amount of free play in the brake lever. The free play should be about 0.2-0.3 in. (5-7 mm).
- Adjust the brakes by turning the adjustment nut clockwise to loosen and counterclockwise to tighten brake tension.
- Recheck the brake lever free distance. Readjust if it is still not within the correct limits.

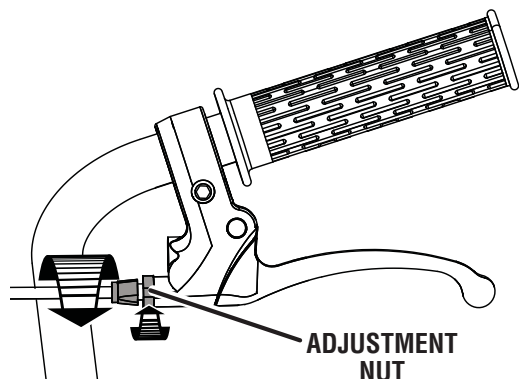

- To make brake pad adjustments, turn the adjusting bolt clockwise to loosen and counterclockwise to tighten brake tension.
- Brake pads should be replaced by a qualified service technician once brake pads are worn.

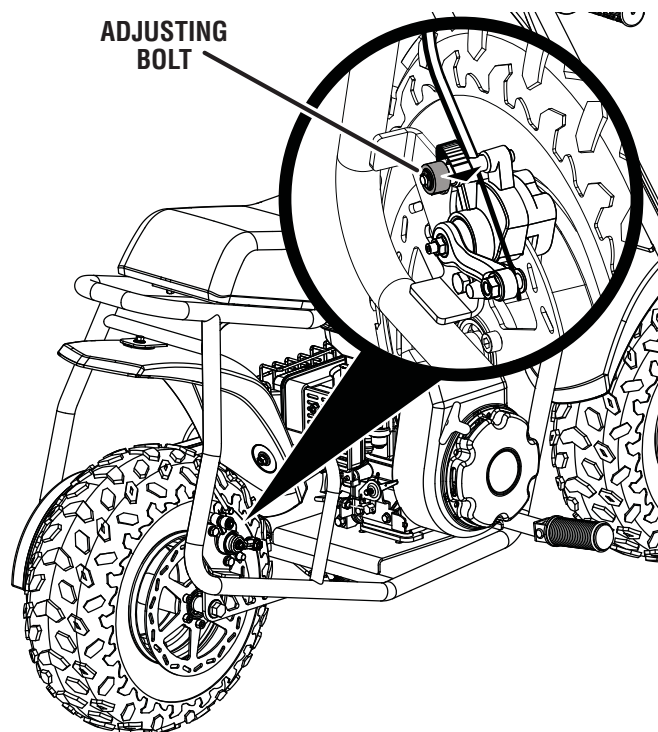

## INSPECTING DRIVE CHAIN/SPROCKETS

The condition and adjustment of the drive chain should be checked before riding. Always follow the guidelines below for inspecting and servicing the chain.

## **⚠ WARNING:**

Always inspect the drive chain before riding the mini bike. Failure to maintain the drive chain properly and/or riding with the chain in poor condition could lead to an accident resulting in serious personal injury.

### Inspecting the drive chain:

When inspecting the drive chain, look for the following:

- Loose pins
- Damaged rollers
- Dry or rusted links
- Kinked or binding links
- Excessive wear

If you find anything wrong with the drive chain, solve the problem by repairing or replacing the chain. If necessary, consult your local authorized service center.

### Inspecting the sprockets:

A worn chain can have an adverse affect on the sprockets, therefore any time you find damage to the drive chain, you should also check the front and rear sprockets. When inspecting the sprockets, look for the following:

- Excessively worn teeth
- Broken or damaged teeth
- Loose sprocket mounting nuts

If you find anything wrong with the sprockets, consult your local authorized service center.

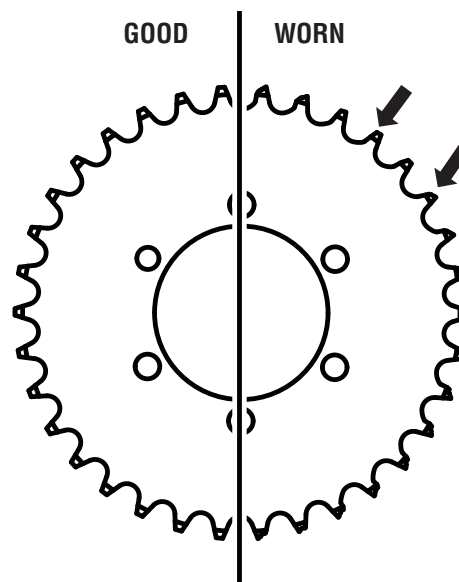

# MAINTENANCE

## CLEANING/ADJUSTING DRIVE CHAIN

The drive chain should be cleaned, lubricated, and inspected every time you ride the mini bike.

### **⚠ WARNING:**

Always inspect the drive chain tension before you ride the mini bike. Too much slack could allow the drive chain to come off the sprockets, which could cause an accident or result in serious damage to the mini bike.

### **Cleaning the drive chain:**

- Wash the drive chain with an approved chain cleaner.
- Dry the chain, then lubricate with chain lubricant or the equivalent.

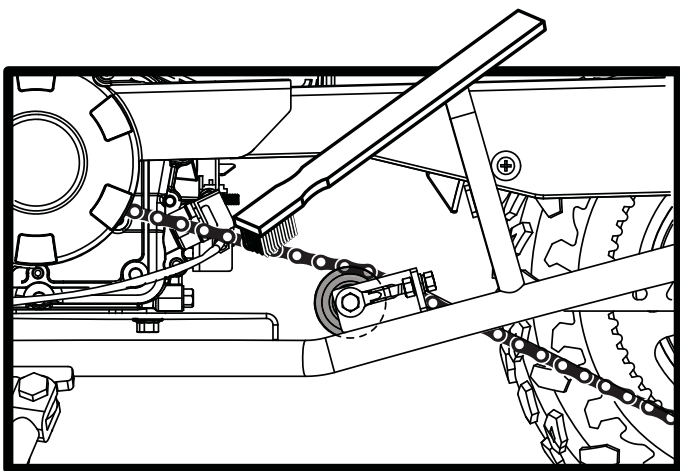

## TIRE MAINTENANCE

This mini bike is equipped with low pressure tubeless tires of the size and type listed below:

	Front	Rear
Size	145x70-6	145x70-6

### **Tire Air Pressure**

Check the air pressure in all tires before riding. Improper air pressure will affect handling, steering response, traction, tire life and rider comfort. Be sure tires are inflated to the pressures shown below.

**NOTE: Tire pressure should only be measured or adjusted when tires are cold.**

Recommended Pressure
5 psi (34.5 kpa)

### **⚠ WARNING:**

Check the tire pressure carefully while inflating. Too much air in the tire could cause the tire to burst, causing serious personal injury.

### **⚠ WARNING:**

Maintaining correct air pressure in the tires is very important. Too little pressure could allow the tire to rotate off the wheel rim. Too much pressure could cause the tire to burst. Failure to maintain correct air pressure in the tires could cause problems with vehicle operation and stability, causing serious personal injury.

## TIRE REPAIR

If a leak or flat tire occurs due to a puncture, the tire may be repaired using a plug-type patch. If the damage is from a cut, or if the puncture cannot be repaired using a plug, the tire should be replaced.

When operating your mini bike in areas where transportation or service facilities are not readily available, keep a plug-type repair kit and tire air pump with you.

## REPLACING TIRES

When tires are worn, the traction of the vehicle will be decreased, which increases the chance of having an accident. Tires should be replaced when the depth on the tread is 0.16 in. (4 mm) or less. Always use identical replacement tires. Using improper tires on the unit could cause loss of control, which could increase your risk of accident.

Have tires replaced by an authorized service center or a qualified tire repair station.

# MAINTENANCE

## CLUTCH MAINTENANCE

After every 5 hours of use, your clutch will need cleaning and lubrication. If the clutch becomes too dirty or lacks lubrication, the clutch will begin to stick, which could cause the mini bike to move without the throttle being applied.

### To clean and lubricate the clutch:

- Turn engine off and allow to cool completely.
- Remove clutch cover.
- Blow through holes in cover using compressed air to remove any dust and/or particles.
- Add a few drops of 30W motor oil to the clutch bearing to lubricate. Do not allow oil to get inside the clutch itself.
- Push mini bike forward without starting to allow oil to flow through bearing surface.
- Replace clutch cover.

### **⚠ WARNING:**

Do not start the mini bike with the clutch cover removed. Starting the engine with the clutch cover removed could allow you to come in contact with moving parts, causing serious personal injury.

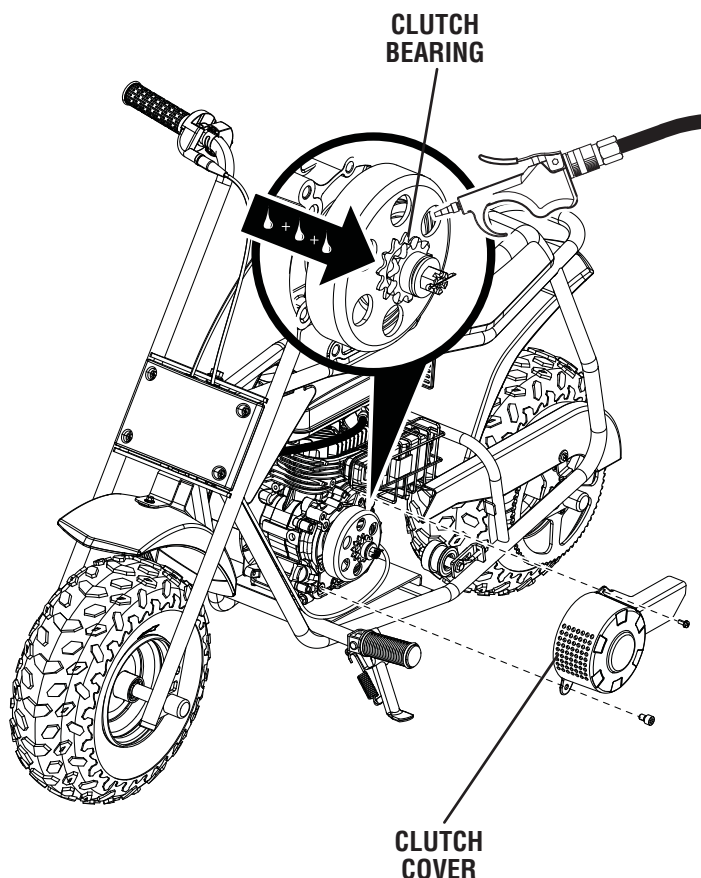

## CLEANING

A thorough cleaning of the mini bike is a necessary part of maintenance. It will help keep the mini bike looking and performing at its best. Proper cleaning can also extend the life of the mini bike.

Clean and inspect the mini bike after every ride, especially if it is used in mud, brush, grass, water, salt water, or very dusty conditions. The build-up of mud, brush, grass, etc., especially on the engine and exhaust system, can reduce engine cooling ability, conceal damage, or increase wear of certain parts. Remove all debris during cleaning.

The mini bike should be washed before any mud dries on the unit. Avoid spraying or allowing water to flow over the ignition switch, spark plug, fuel tank cap, carburetor, drive chain, or air filter.

**NOTE:** Do not use high pressure washers such as those found at car washes. They could cause mechanical, electrical and other damage.

- Hand wash the unit with mild soap or detergent and water. Try to thoroughly remove all dirt and debris without excessive water pressure. Cloth rags, washing mitts, or cleaning brushes can be used, but be careful with brushes as they can scratch plastic or painted surfaces.
- Rinse the unit thoroughly with clean water.
- Dry all areas using a chamois or soft absorbent cloth or allow the unit to air dry.
- Lubricate the chain and run the engine at idling speed for a few minutes.
- Follow the procedures in **Pre-Ride Inspection** to check the unit for any problems that may have occurred during your last ride.
- After washing your mini bike, test your brakes by riding at a slow speed. If necessary, apply brake several times to let the friction dry out the brake linings. Wet brakes may not provide as much stopping power as dry brakes.

### **⚠ WARNING:**

Operating the mini bike at high speeds when the brakes are wet could result in serious personal injury.

# MAINTENANCE

## STORING THE MINI BIKE

If you do not use the mini bike for a long time, it will need special service requiring appropriate materials, equipment, and skill. For this reason, we recommend you trust this maintenance work to an authorized service center. If you wish to service the machine for storage yourself, follow the general guidelines.

### ENGINE LUBRICANT:

- Change the engine lubricant.

### FUEL:

- Drain the fuel from the fuel tank using a hand pump. Spray atomized anti-rust oil onto the inside wall of the tank and then close the tank.
- Drain the fuel from the carburetor by releasing the carburetor drain screw.

**NOTE:** Used fuel should be disposed of properly to comply with local laws and ordinances and not adversely affect the environment.

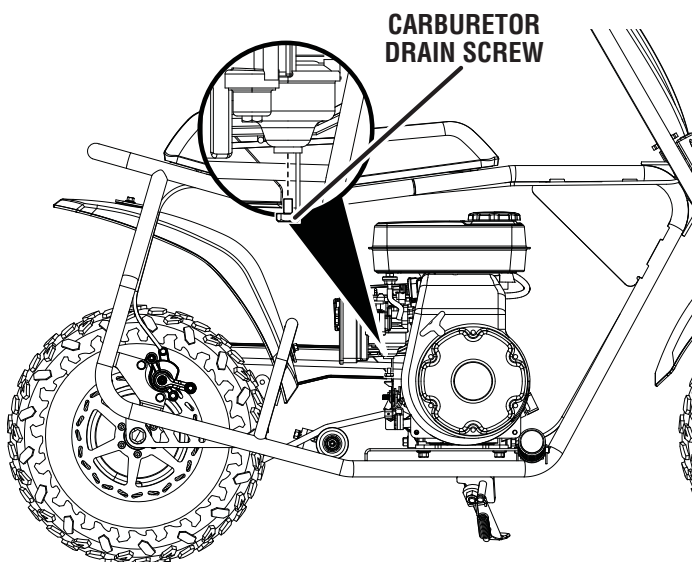

### SPARK PLUG:

- Take out the spark plug.
- Pour approximately 0.5-0.68 oz. (15-20 ml) of clean engine lubricant into the cylinder.
- Pull the pull cord half way several times to distribute the oil through the engine.
- Replace the spark plug.

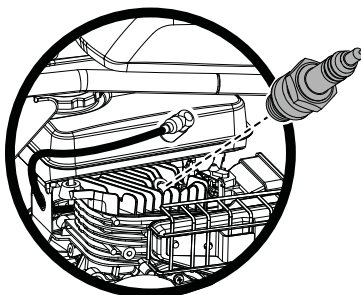

### TIRES:

- Inflate the tires to the normal pressure.

**NOTE:** Tire pressure should only be measured or adjusted when tires are cold.

Recommended Pressure
5 psi (34.5 kpa)

### WARNING:

Check the tire pressure carefully while inflating. Too much air in the tire could cause the tire to burst, causing serious personal injury.

### WARNING:

Maintaining correct air pressure in the tires is very important. Too little pressure could allow the tire to rotate off the wheel rim. Too much pressure could cause the tire to burst. Failure to maintain correct air pressure in the tires could cause problems with vehicle operation and stability, causing serious personal injury.

### VEHICLE:

- Place the vehicle on level ground.
- Wash the vehicle.
- Spray all vinyl and rubber parts with rubber protection.
- Spray unpainted surfaces with rust preventative.
- Coat painted surfaces with car wax.
- Store the mini bike up on wooden blocks with the two wheels clearing the ground. Put the vehicle in a shady and cool place free from humidity and direct sunlight. Cover it properly (not with plastic or painted materials). If possible, store in a garage.

### PROCEDURE FOR RETURNING VEHICLE TO SERVICE:

- Change engine lubricant if unit has been out of service longer than 4 months.
- Drain atomized anti-rust oil from the fuel tank and fill with fresh gasoline.
- Clean the entire vehicle.
- Make sure the vehicle is properly lubricated.
- Perform the **Pre-Ride Inspection** as listed previously.

# TROUBLESHOOTING

This troubleshooting guide is provided to help you find the cause of some common complaints. If these solutions do not solve the problem contact your authorized service dealer.

## **COMPLAINT: Engine is hard to start or does not start at all.**

1. Check that the fuel valve is in the ON position.
2. Check that the choke lever is in the ON position.
3. Make sure there is adequate fuel in the fuel tank.
4. Drain fuel from tank and carburetor. Replenish with fresh gasoline.
5. Remove and inspect the spark plug. Clean, dry, gap, or replace as needed.
6. Take the mini bike to a qualified mechanic to replace or repair faulty components as needed.

## **COMPLAINT: Engine lacks power.**

1. Follow the procedures in **Checking/Cleaning the Air Filter** to be sure the air filter is clean.
2. Check for correct position of choke lever.
3. Drain fuel from tank and carburetor. Replenish with fresh gasoline.
4. Check idle speed and adjust, if necessary, following the procedures in **Idle Speed Adjustment**.
5. Take the mini bike to a qualified mechanic to replace or repair faulty components as needed.

# EMISSIONS WARRANTY

## BAJA, INC. – EMISSION CONTROL SYSTEM WARRANTY

### YOUR WARRANTY RIGHTS AND OBLIGATIONS

This emission control system warranty is part of your purchase agreement and applies to the ultimate purchaser (the first person who in good faith purchases the product for purposes other than resale) and each subsequent purchaser. The emission control system warranty period for this vehicle begins on the date the vehicle is first placed into service by the ultimate purchaser and continues for 30 months after that date, or 5,000km, whichever comes first, provided there has been no abuse, neglect or improper maintenance of your vehicle. This vehicle is designed, built and equipped to meet U.S. EPA emission standards for the full useful life of the vehicle. Where a warrantable condition exists, Baja, Inc. will repair your vehicle at no cost to you, including diagnosis, parts and labor. If an emission-related part on your vehicle is defective, the part will be repaired or replaced by Baja, Inc. This is your emission control defects warranty.

### OWNER'S WARRANTY RESPONSIBILITIES

As the vehicle owner, you are responsible for the performance of the required maintenance. You should maintain a record of all maintenance performed on your vehicle and retain all receipts covering maintenance on your vehicle. You may not be denied a warranty claim solely because of your failure to ensure the performance of all scheduled maintenance or lack of maintenance records or receipts. You are responsible for presenting your vehicle to an authorized dealer as soon as a problem exists. The warranty repairs should be completed in a reasonable amount of time, not to exceed 30 days.

As the vehicle owner, you should be aware that you may be denied your warranty coverage if your vehicle or a part has failed due to abuse, neglect, improper maintenance, or unapproved modifications.

### WARRANTY COVERAGE:

Baja, Inc. warrants that each new 2010 and later vehicle:

- is designed, built, and equipped so as to conform at the time of initial retail purchase with all applicable regulations of the United States Environmental Protection Agency, and the California Air Resources Board; and
- is free from defects in material and workmanship which cause such vehicle to fail to conform with applicable regulations of the United States Environmental Protection Agency or the California Air Resources Board for the periods specified above.

Your emission control system warranty covers components whose failure would increase an engine's emission, including electronic controls, fuel injection system, carburetor, the ignition system, catalytic converter, or any other system utilized in this vehicle to control emission if it is originally equipped. Also included may be hoses, connectors and other emission-related assemblies. Replacing or repairing other components (including parts, labor, and other costs) not covered by this emission control system warranty or the standard warranty is the responsibility of the owner.

Coverage of repairs under this warranty applies only when repairs are completed at an authorized dealer or repair facility. Baja, Inc. will not cover repairs performed outside of an authorized dealer or repair facility, except to correct an unsafe, emergency condition attributable to Baja, Inc. The use of replacement parts not equivalent to the original parts may impair the effectiveness of your vehicle's emission control system. If such a replacement part is used and an authorized dealer determines it is defective or causes a failure of a warranted part, your claim for repair to bring your vehicle into compliance with applicable standards may be denied.

If an unsafe, emergency condition exists attributable to Baja, Inc., repairs may be performed at any available service establishment, or by the owner, using any replacement part, as long as the operator tries to restore the engine/equipment to its proper configuration as soon as possible. Baja, Inc. will reimburse the owner for the expenses,

including diagnostic charges, not to exceed Baja, Inc.'s suggested retail prices for all warranted parts replaced and labor charges based on Baja, Inc.'s recommended time allowance for the warranty repair and the geographically appropriate hourly labor rate. The owner may reasonably be required to keep receipts and failed parts in order to receive compensation.

This Emission Control System Warranty is in addition to the standard Limited Warranty.

### EXCLUSIONS AND LIMITATIONS:

This warranty does not cover the following:

- Failures or malfunctions of the emission control systems caused by abuse, alteration, accident, misuse, the use of leaded gasoline.
- Replacement of expendable maintenance items unless they are original equipment defective in material or workmanship under normal use, and the first required replacement interval for the item has not been reached. Expendable maintenance items include but not limited to spark plugs, filters, coolant, lubricants, gaskets, hoses, and belts.
- Replacements of parts and other services and adjustments for required maintenance.
- Any vehicle equipped with an odometer or hour meter where the reading is altered so that actual mileage cannot be readily determined.
  - Repairs or replacements as a result of accident, misuse, or use of replacement parts or accessories not conforming to the original specifications which adversely affect performance
- Physical damage, corrosion, or defects caused by fire, explosions or similar causes beyond the control of Baja, Inc.
- Failures not caused by a defect in material or workmanship.

Use of the vehicle in any type of competitive racing or related events immediately and completely voids this and all other warranties. Failure to follow the recommended jetting chart/altitude adjustments, if applicable, or other unauthorized modifications, will be considered improper maintenance and use of the vehicle, and may result in the denial of warranty claims.

### LIMITED LIABILITY

The liability of Baja, Inc. under this Emission Control System Warranty is limited solely to the remedying of defects in material workmanship by an authorized dealer at its place of business during customary business hours. This warranty does not cover inconvenience or loss of use of the vehicle or transportation of the vehicle to/from the authorized dealer. Baja, Inc. is not liable to any person for incidental, consequential or special damages of any description, whether arising out of express or implied warranty or any other contract, negligence or other tort or otherwise.

No express emission control system warranty is given by Baja, Inc. except as specifically set forth herein. Any emission control system warranty implied by law, including any warranty of merchantability or fitness for a particular purpose is limited to the express emission control system warranty term stated in this warranty. The foregoing statements of warranty are exclusive and in lieu of all other remedies. All express warranties not stated in this warranty are disclaimed. Some states do not allow limitations on how long an implied warranty lasts, so the above limitations may not apply if it is inconsistent with the controlling state law.

No dealer is authorized to modify this Emission Control System Warranty. If you have any questions regarding your warranty rights and responsibilities, you should contact BAJA, INC., (888) 863-2252, 1428 Pearman Dairy Road, Anderson, SC 29625, or the California Air Resources Board, 9528 Telstar Avenue, El Monte, CA 91731 (for California registered vehicles only).

# PRODUCT SPECIFICATIONS

## DIMENSIONS AND DRY MASS:

Overall length ..... 50 in. (1270 mm)  
Overall width..... 24.2 in. (614.7 mm)  
Overall height ..... 34.6 in. (878.8 mm)  
Wheelbase..... 36 in. (914.4 mm)  
Ground clearance ..... 3.1 in. (78.7 mm)  
Seat height ..... 23.6 in. (599.4 mm)  
Dry weight..... 77 lbs. (34.9 kg)

## ENGINE:

PTO shaft rotation ..... Counterclockwise  
Bore and stroke ..... 52 mm x 46 mm  
Displacement..... 98cc  
Compression ratio ..... 5:6:1  
Rated power ..... 3,600 r/min. (1.8kW)  
Rated torque..... 2,500 r/min. (3.8 Nm)  
Starting method ..... Recoil Pull Start  
Idle speed ..... 1500 ± 150 RPM

## ELECTRICAL:

Ignition type ..... TCI  
Spark plug ..... NGK BP7HS  
Spark plug gap ..... 0.028-0.031 in. (0.7-0.8 mm)

## CAPACITIES:

Engine lubricant..... 0.40 qt. (0.45 l) SAE15W40  
Fuel tank..... 0.36 gal. (1.4 l)  
Payload..... 150 lbs. (68 kg)

## BRAKES:

Brake type ..... Disc

## TIRES:

Front ..... 145x70-6  
Rear..... 145x70-6

## WARNING:

This product contains chemicals known to the State of California to cause cancer, birth defects, or other reproductive harm.

### CALIFORNIA PROPOSITION 65

## BAJA MOTORSPORTS

1428 Pearman Dairy Road  
Anderson, SC 29625  
1-888-863-2252  
[www.bajamotorsports.com](http://www.bajamotorsports.com)