

REVISION HISTORY					
ZONE	REV	DESCRIPTION	DATE	BY	ECO
-	B	INITIAL DRAWING	29AUG13	JPM	15390

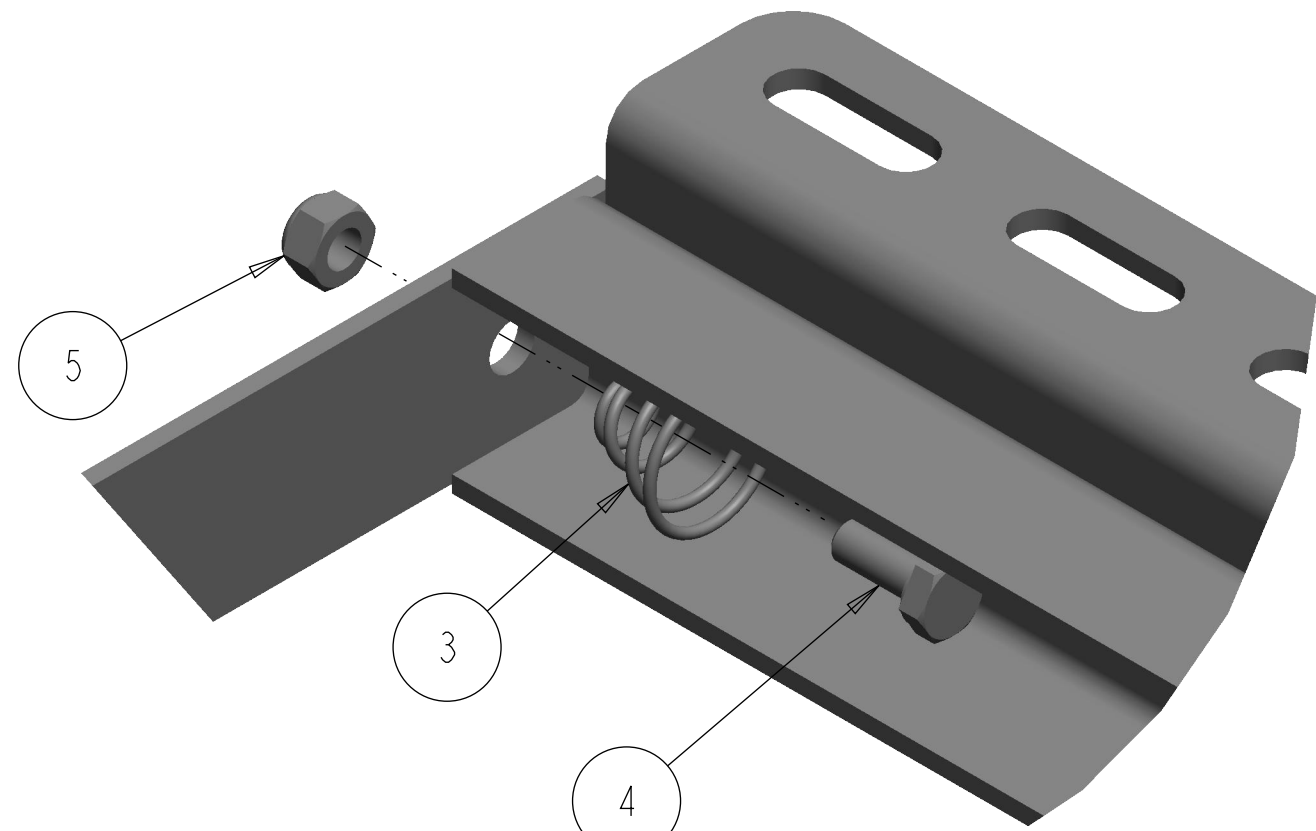

2X SPRING INSTALLATION
DETAIL A
SCALE 1.000

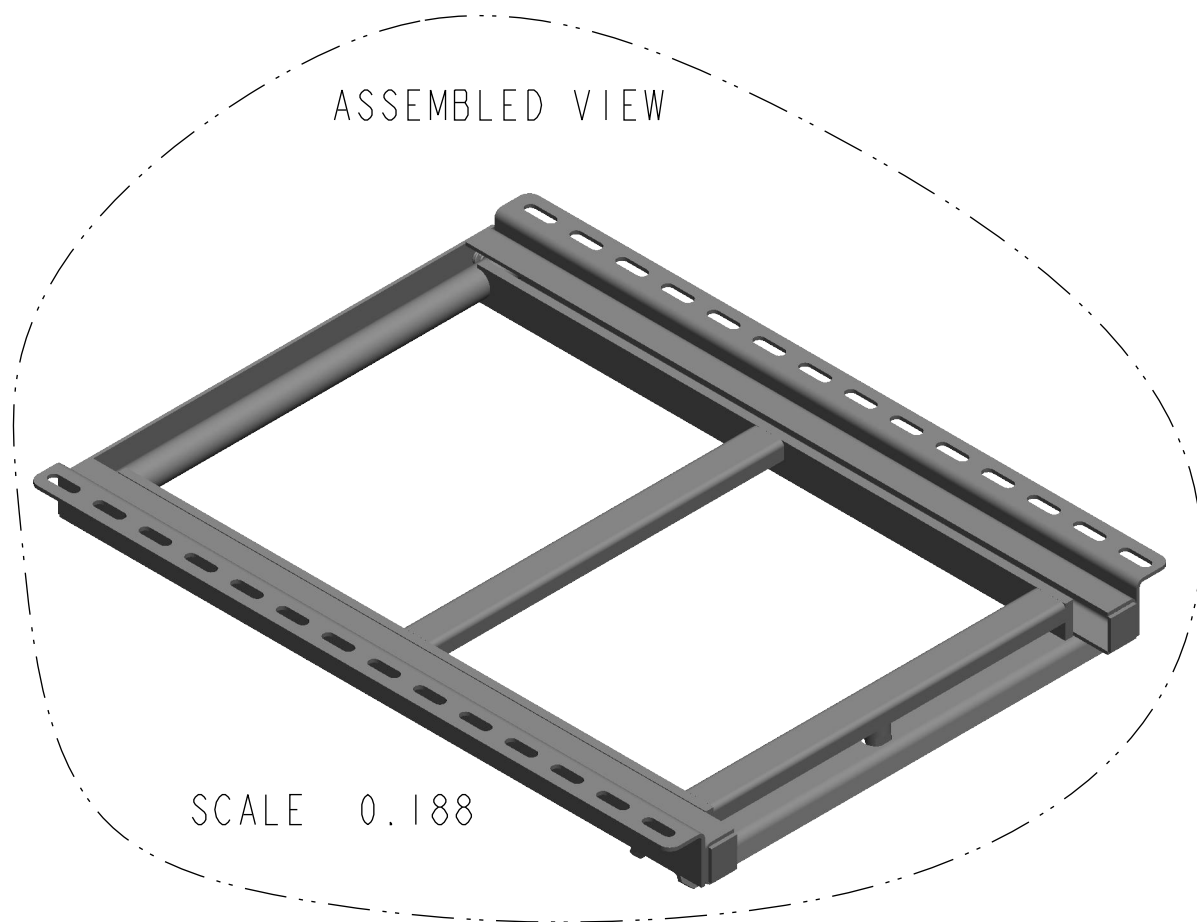
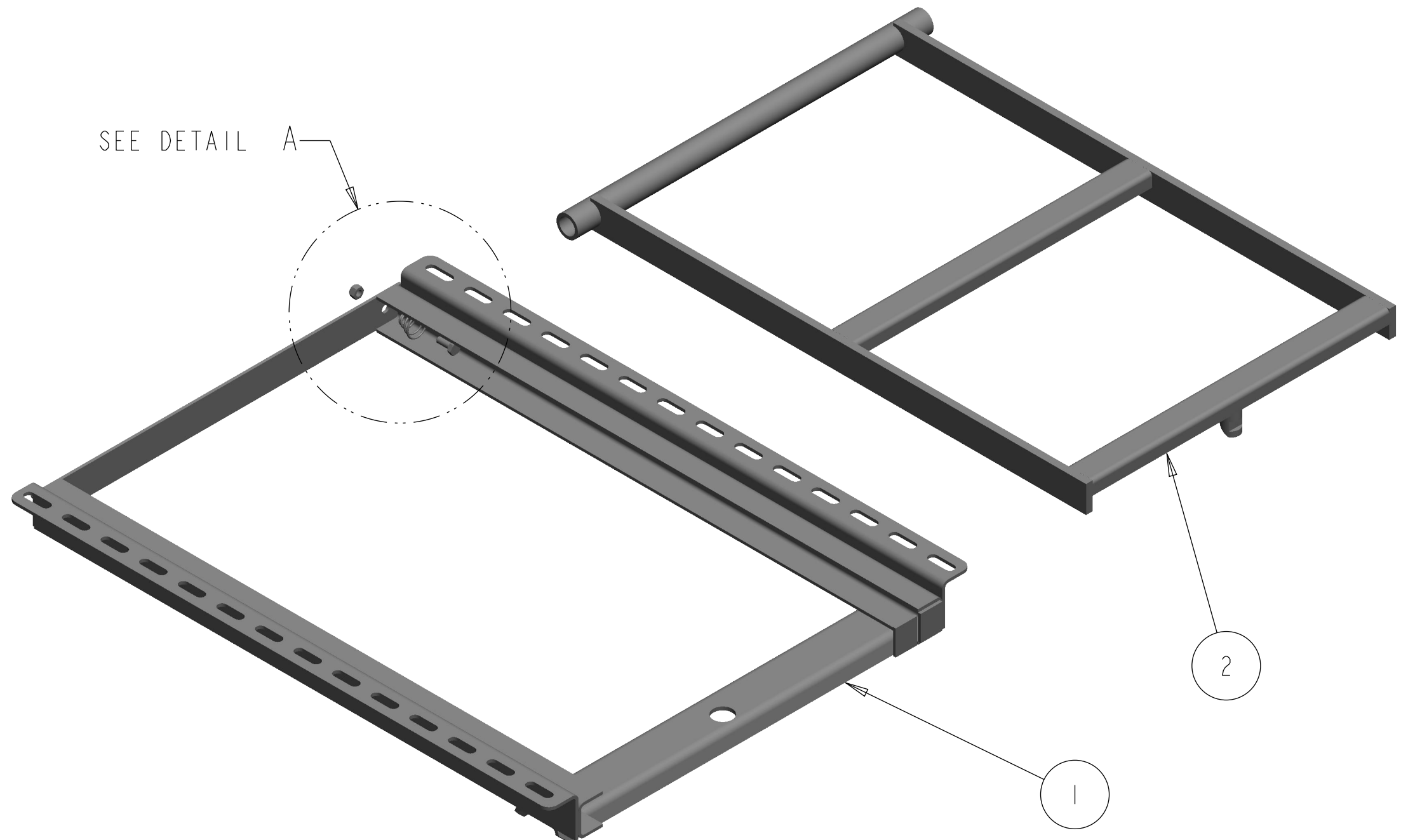

ASSEMBLED VIEW

SCALE 0.188

BILL OF MATERIALS			
ITEM	PART NO.	QTY.	DESCRIPTION
1	3024009	1	MOUNT, FRAME, STEP 2 RUNG SST
2	3024019	1	STEP, WELDMENT, 2 RUNG SST
3	3023999	2	SPRING, CONICAL, RETRACTABLE STEP
4	FCS025020063SS	2	SCREW, CAP 1/4-20 X 5/8" GR 5 SST
5	FNE02502003ISS	2	NUT, NYLON INSERT 1/4-20 SST

- NOTES:
1. SPRINGS TO BE INSTALLED ONTO FRAME WELDMENT USING HARDWARE SHOWN
 2. STEP WELDMENT TO BE INSTALLED INTO MOUNTING FRAME
 3. COMPLETED ASSEMBLY TO BE PACKED WITH PAPER AND BOXED
 4. BOX TO BE LABELED WITH PART NUMBER, DESCRIPTION, AND UPC CODE

MATERIAL	SEE BOM	NAME	JPM	DATE	29AUG13	 PHONE (440) 974-8888 9049 TYLER BLVD, MENTOR, OH 44060 FAX (440) 974-0165
		CHK		DATE		
		APP		DATE		
ALL SHEETS ARE THE SAME REVISION STATUS		UNLESS OTHERWISE SPECIFIED DIMENSIONS ARE IN INCHES		TITLE		TRUCK STEP, RETRACTABLE LADDER, 2 RUNG SST
THIS ITEM IS A PROPRIETARY ITEM OF BUYERS PRODUCTS CO. AND REPRODUCTION OR USE THEREOF IN ANY MANNER WHATSOEVER IS UNAUTHORIZED EXCEPT WITH THE EXPRESS WRITTEN CONSENT OF BUYERS PRODUCTS CO. ANY USE DETRIMENTAL IN ANY WAY TO THE INTERESTS OF BUYERS PRODUCTS CO. IS EXPRESSLY PROHIBITED.		.X ± .1 < ±1°		SIZE		
		.XX ± .03		CAGE CODE		DWG. NO. 5232001 REV B
		.XXX ± .010		SCALE		
		INTERPRET DIM AND TOL PER ASME Y14.5		0.25		WEIGHT
				-		SHEET
						1 of 1