

OWNER'S INSTRUCTIONS DIY TRAILER KIT

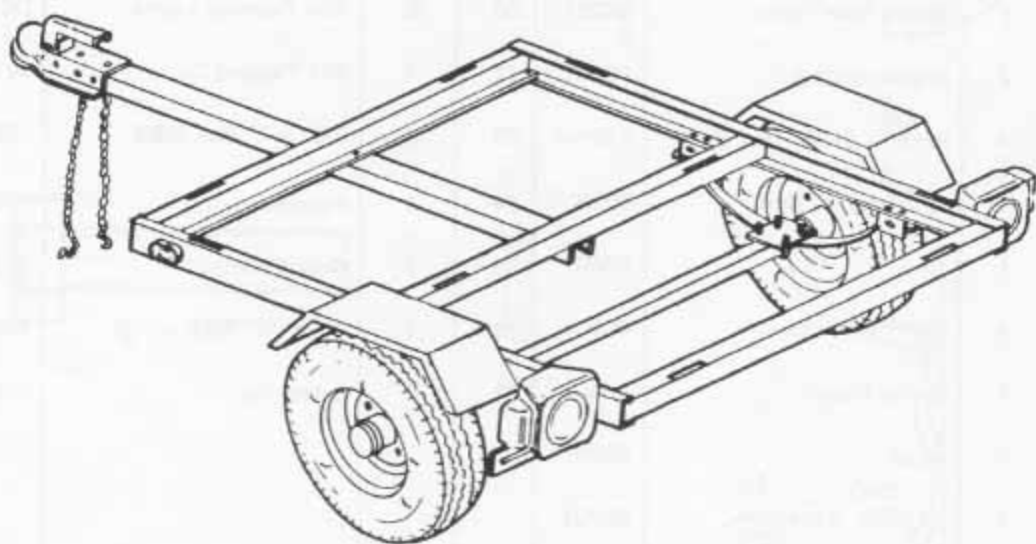

Item No.: LCI-830T
 LCI-830TA

LCI-830T TRAILER PARTS LIST

NO.	QTY.	DESCRIPTION	PARTS NO.	NO.	QTY.	DESCRIPTION	PARTS NO.
1	29	3/8" x 3/4" Hex Bolts	105EH	23	1	Coupler	C0101
2	16	3/8" Spring Washers	302E	24	1	3/8" x 1 1/2" Bolts	111EH
3	46	3/8" Nylon Nuts	202E	25	1	Safety Chain	C0201
4	3	Cross Members	A0201	26	5	3/8" Flat Washer	301E
5	1	Left Side Rail	A0101	27	2	Tail Light Bracket	D0901
5A	1	Right Side Rail	A0102	28	1	License Plate Bracket	D1002
6	1	Towbar	A0501	29	1	Left Tail Light	D1102
7	4	Spring Hangers	B0101	29A	1	Right Tail Light	D1101
8	2	Spring Slide Plates	B0201	30	2	Side Running Lights	D0701
9	2	Slipper Springs	B0301	31	4	Self Tapping Screw	501H1
10	4	9/16" x 3-1/8" Hex Bolts	120HH	32	8	3/8" x 1" Hex Bolts	107EH
11	4	9/16" Nylon Nuts	201H	34	2	Fenders	D0501
12	1	Axle	B0601	35	2	Grease Fitting	B1301
13	4	3/8" "U" Bolts	B0501	36	1	2mm "R" Pin	402D1
14	2	Spring Plates	B0401	37	1	Safety Pin	502C1
15	2	Hubs	B0801				
16	2	Tire/Rim Assembly	B0701				
17	8	Lug Nuts	205G				
18	2	Bearings	B0901				
19	2	3/4" Flat Washers	301J				
20	2	Castle Nuts (on axle)	204J				
21	2	5/32" Cotter Pins	401H1				
22	2	Dust Caps	B1001				

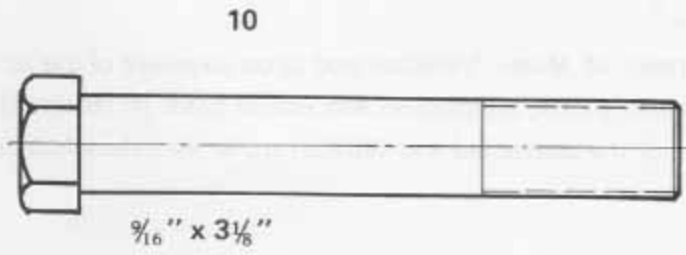
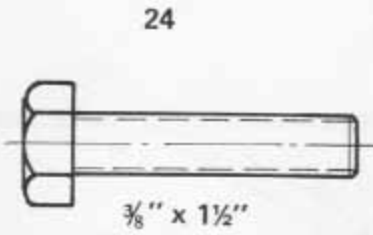
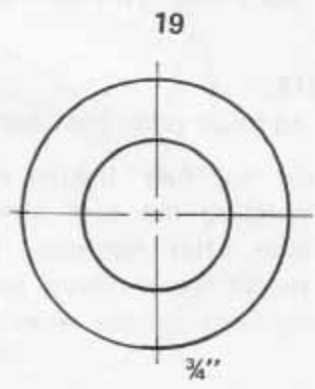
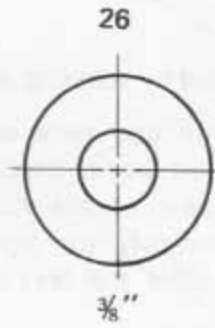
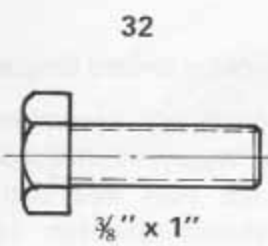
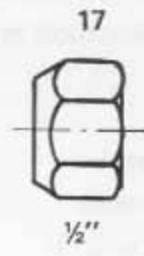
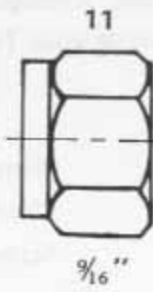
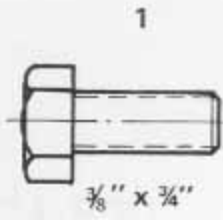

Read the instructions carefully and follow them step-by-step for easy assembly. You'll find a complete parts list on the previous page. Average assembly time is approximately 4 hrs. You'll need the following tools to assemble your Trailer Kit.

TOOLS NEEDED:

9/16" box end wrench
9/16" open end wrench
3/4" socket or lug wrench
Electric Drill or hand drill
(for installing plywood base)

Pliers
Channel lock pliers
Screwdriver

NOTE:

1. All trailer parts are identified by standing at rear of trailer and looking toward tongue.
2. Do not fully tighten bolts and nuts until the trailer is completely assembled. Installing the 3/4" plywood base, which you will have to supply, is the last step after tightening down all the nuts and bolts. All the nuts and bolts should be checked periodically for tightness.... and you should retighten the lug bolts on the wheels after the first 20 miles of use.

TRAILER LICENSING NOTICE

Some states may consider that this trailer kit is a specially constructed or homemade vehicle for registration, licensing and/or titling purposes.

The M.C.O. (Manufacturer's Certificate of Origin) supplied with your trailer should be filled out and signed by the dealer transferring ownership to you.

When licensing your trailer, you will need the signed M.C.O., a purchase invoice, cash register receipt, or bill of sale showing the purchase and retail sales tax or use tax collection by the retailer.

Take these to your local Department of Motor Vehicles and upon payment of the appropriate State fees, you will be issued a title, registration and license plate (if required). Some states will require inspection of the assembled and finished trailer kit before issuing a title registration/license.

If you require additional information or guidance on licensing or titling, please consult your State Department of Motor Vehicles.

ДИАГРАММА ОСНОВНЫХ ЧАСТЕЙ
DIAGRAM OF MAIN PARTS.

LCI-830

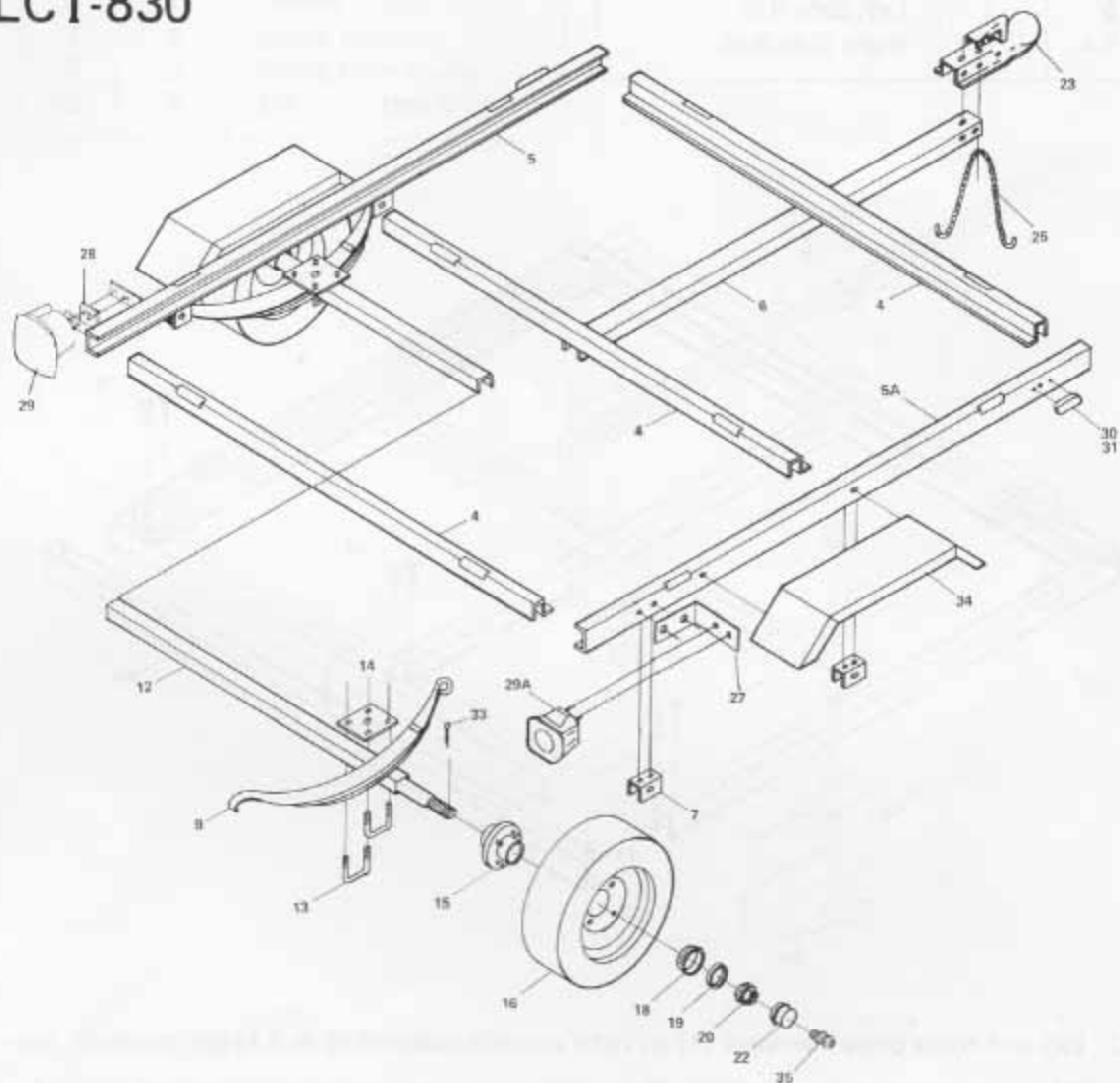

STEP 1

ASSEMBLY INSTRUCTIONS:

PARTS NEEDED		
NO.	QTY.	DESCRIPTION
1	12	3/8" x 3/4" Hex Bolts
3	12	3/8" Nylon Nuts
4	3	Cross Members
5	1	Left Side Rail
5A	1	Right Side Rail

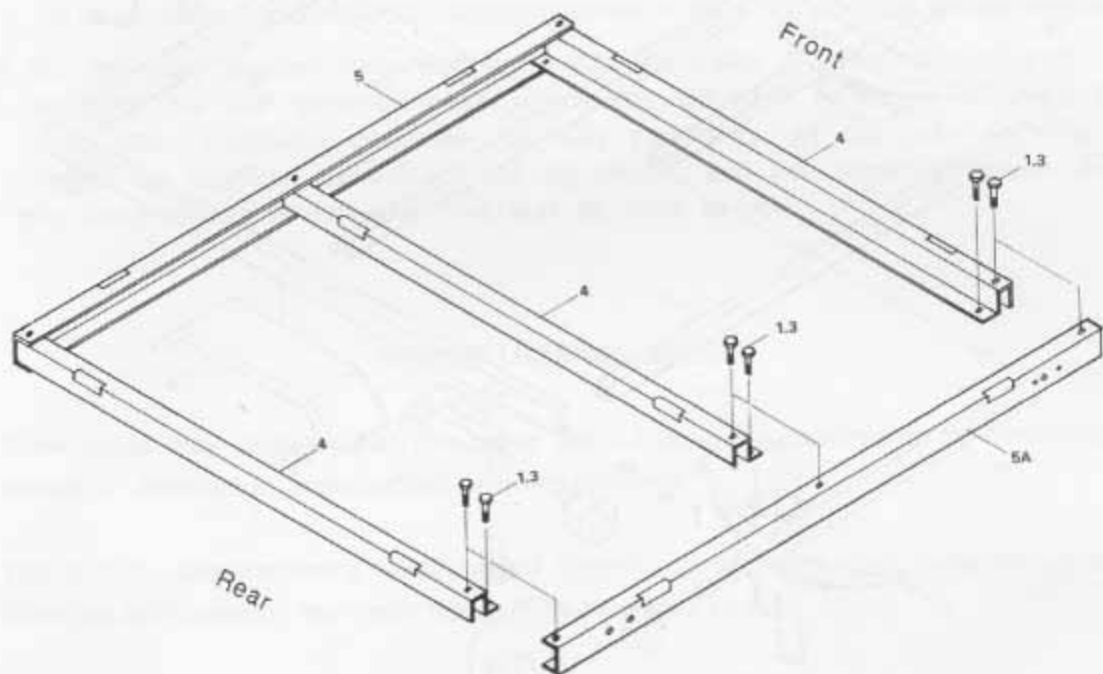

1. Lay out three cross members (4) to right and left side rail (5 & 5A) as shown in diagram.
2. Assemble (4, 5, 5A) by using 3/8" x 3/4" hex bolts (1) and 3/8" nuts (3), with flat flanges of cross member positioned as shown in diagram.
3. Do not tighten nuts until all bolts are positioned in place.

STEP 2

PARTS NEEDED		
NO.	QTY.	DESCRIPTION
1	4	3/8" x 3/4" Hex Bolts
2	8	3/8" Spring Washers
3	12	3/8" Nylon Nuts
6	1	Towbar
7	4	Spring Hangers
8	2	Spring Slide Plates
32	8	3/8" x 1" Hex Bolts

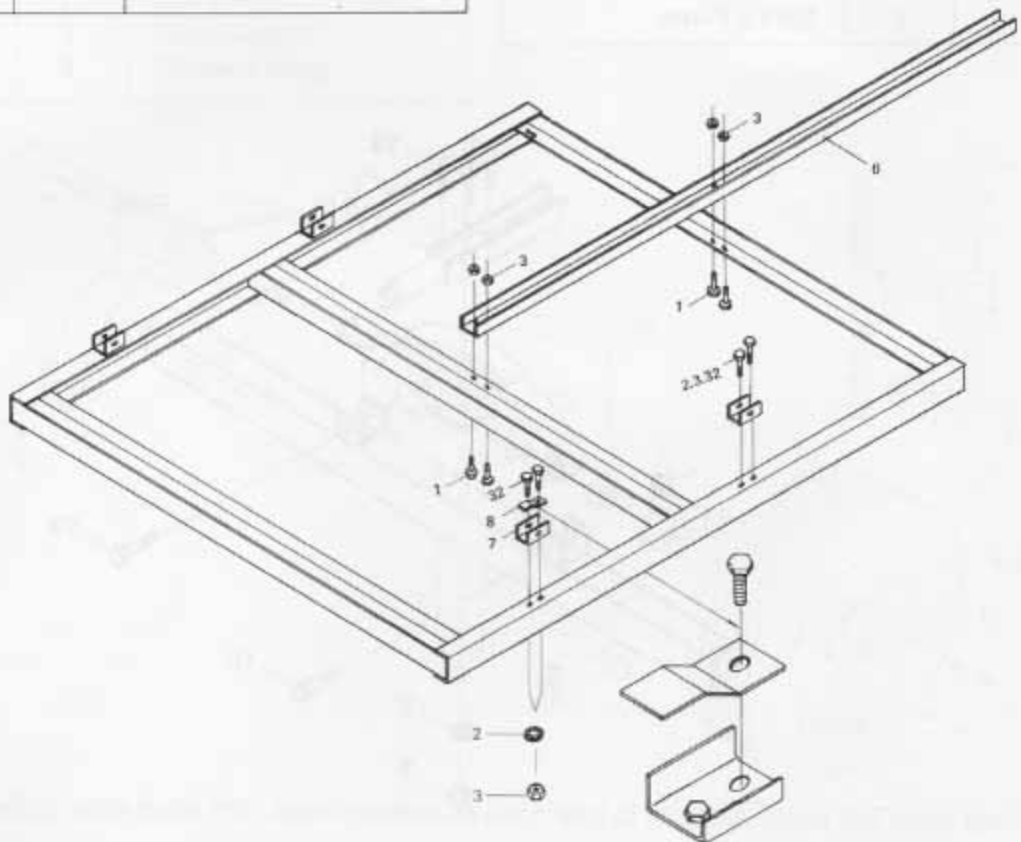

1. Turn the trailer assembly upside down.
2. Bolt towbar (6) with hex bolts and nuts (1, 3). Notice the bolt direction as shown in diagram.
3. Bolt front spring hangers (7) to side rails (5, 5A) with hex bolts, spring washers and nuts (2,3,32). Attach another spring hanger with one bolt in toward rear of trailer, then cover this bolt head with spring slide plate (8) and spring hanger as shown in diagram.

STEP 3

PARTS NEEDED

NO.	QTY.	DESCRIPTION
2	8	3/8" Spring Washers
3	8	3/8" Nylon Nuts
9	2	Slipper Springs
10	4	9/16" x 3-1/8" Bolts
11	4	9/16" Nylon Nuts
12	1	Axle
13	4	3/8" "U" Bolts
14	2	Spring Plates

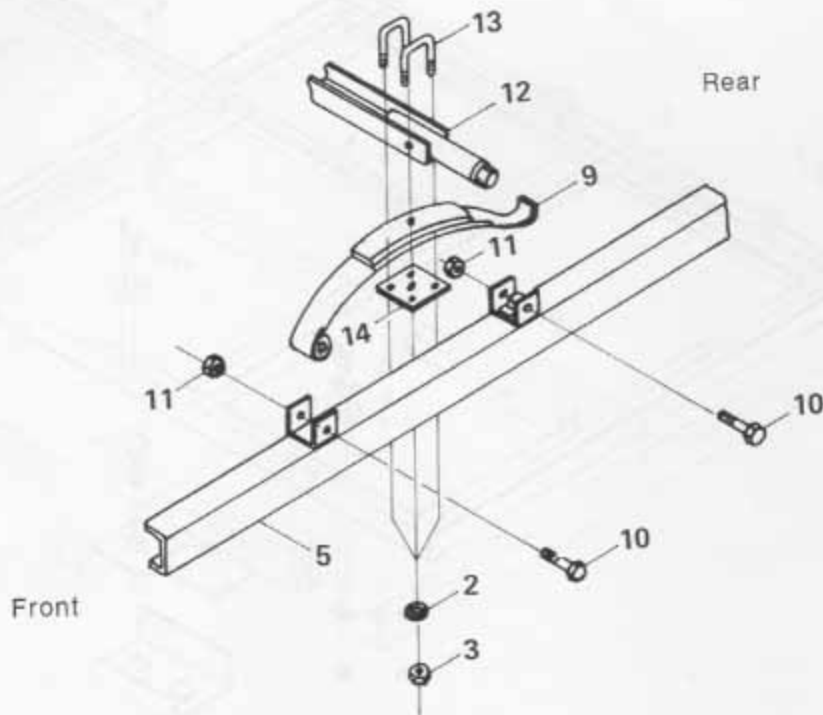

1. Put the slipper springs (9) on the spring hangers (7) with spring eyes forward. Secure with 9/16" x 3-3/8" bolts (10) by going through spring hangers. Lock it with nuts (11).
2. Place axle (12) on top of slipper springs (9). Insert the bolt head of slipper spring into both holes on axle. Place spring plate (14) under slipper spring, using 3/8" U bolt (13) pass through axle, slipper spring and spring plate, then lock with spring washers (2) and 3/8" nuts (3).

STEP 4

PARTS NEEDED		
NO.	QTY.	DESCRIPTION
15	2	Hubs
16	2	Tires
17	8	Lug Nuts
18	2	Bearings
19	2	3/4" Flat Washers
20	2	Castle Nuts
21	2	Cotter Pins
22	2	Dust Caps
35	2	Grease Fitting

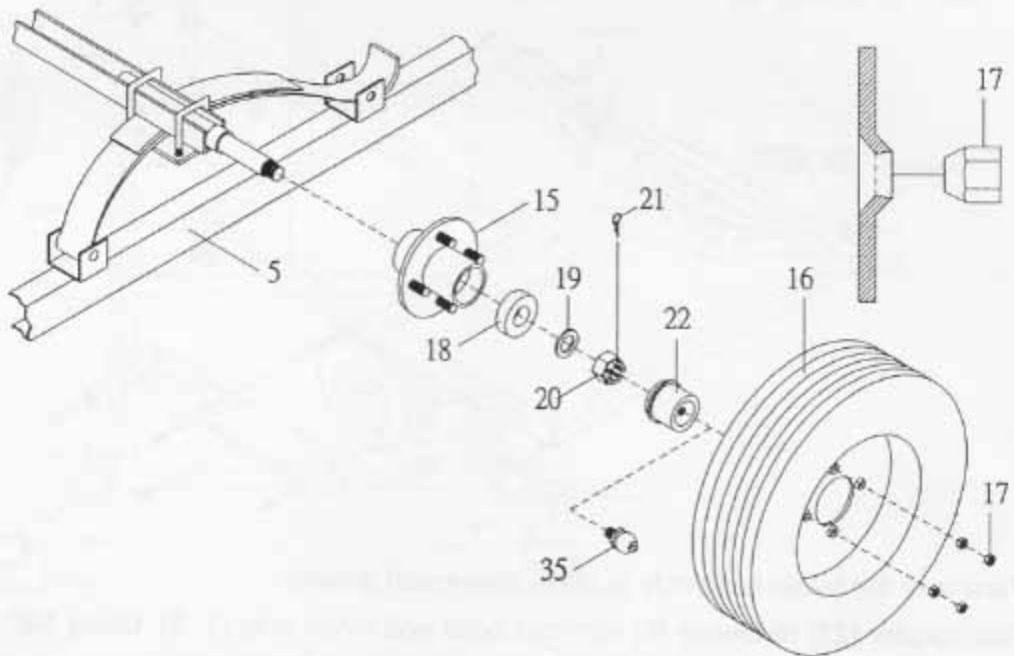

1. Carefully slide hubs (15) over spindles at each end of the axle. Push the outer bearings (18) into each spindle. Place the 3/4" flat washer (19), then castle nuts (20) on each spindle, tightening them snugly. Note: Back castle nut off slightly so that the wheel can spin freely.
2. Push a cotter pin (21) through the hole at the end of the spindle. Spread the cotter pin. Fill the dust cap (22) 1/4 full of automotive grease then press it onto the hub. Attach grease fitting (35) onto dust cap (22).
3. Put tire (16) on hub set. Lock hub in place with lug nuts (17), tightening with socket or lug wrench to 90 ft. lbs. NOTE: Air valve should be on outside of rim. Be sure that axle is perpendicular to side rails and springs are parallel to side rails.

STEP 5

PARTS NEEDED					
NO.	QTY.	DESCRIPTION	NO.	QTY.	DESCRIPTION
1	13	3/8" x 3/4" Hex Bolts	29A	1	Right Tail Light
3	14	Nylon Nuts	30	2	Side Running Lights
23	1	Coupler	31	4	Self Tapping Screw
24	1	3/8" x 1 1/2" Bolt	34	2	Fenders
25	1	Safety Chain	36	1	2mm R Pin
26	5	3/8" Flat Washer	37	1	Safety Pin
27	2	Tail Light Bracket			
28	1	License Plate Bracket			
29	1	Left Tail Light			

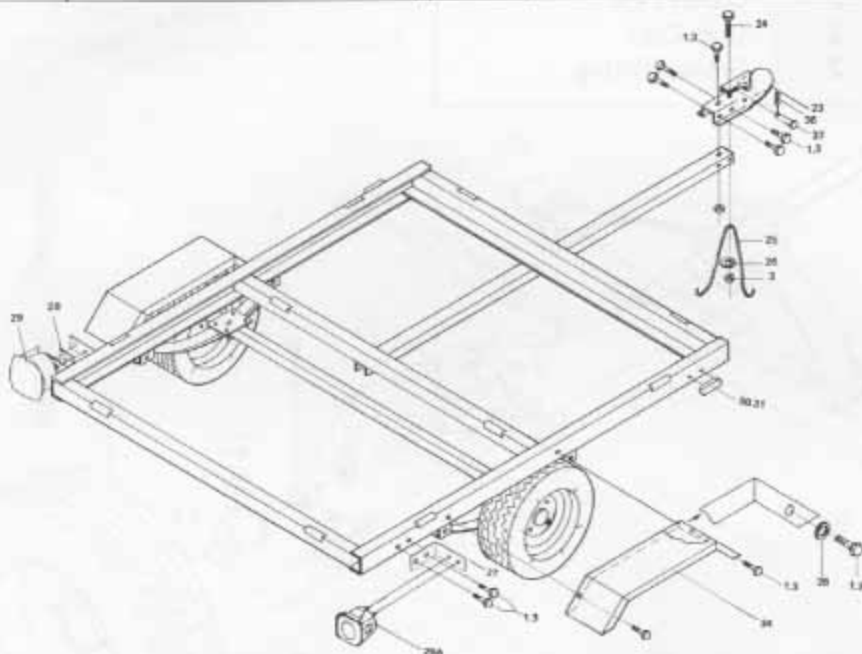

1. Turn over the trailer assembly to make tires touch ground.
2. Bolt coupler (23) to towbar (6) with hex bolts and nylon nuts (1, 3). Using 3/8" x 1-1/2" bolt head (24) outboard, attach safety chain (25) and flat washer (26), then lock it with nut (3). Insert safety pin (37) through the latch hole of coupler (23), then with 2 mm R pin (36) to lock your trailer. NOTE: Make sure safety chain is same length on each side.
3. Attach tail light brackets (27) with bolts and nuts (1, 3), making sure protruding leg of bracket is forward. Install license plate bracket (28) and left tail light (29) (with clear lens for light) with nuts. Install right tail light (29A).
4. Open the lens of side running lights (30). Run wire lead through the center hole and tight to side rails using self tapping screw (31).
5. Bolt fenders (34) to side rails by using 3/8" x 3/4" hex bolts (1), 3/8" flat washers (26) and 3/8" nylon nuts.

TRAILER LIGHT KIT WIRING DIAGRAM AND INSTRUCTION

Check alignment of all parts and install the 4-wire vehicle connector in the trunk area of your car. Locate the connector plug near the hitch ball and lay out wires. Connect the white wire to the frame or body of the car; connect the brown wire to the tail light by stripping, wrapping and taping connector; similarly connect the yellow wire to the left signal and stop light wire and the green wire to the right signal and stop light wire. Some foreign vehicles may require an adaptor to convert their 5 wire system to wire vehicle connector.

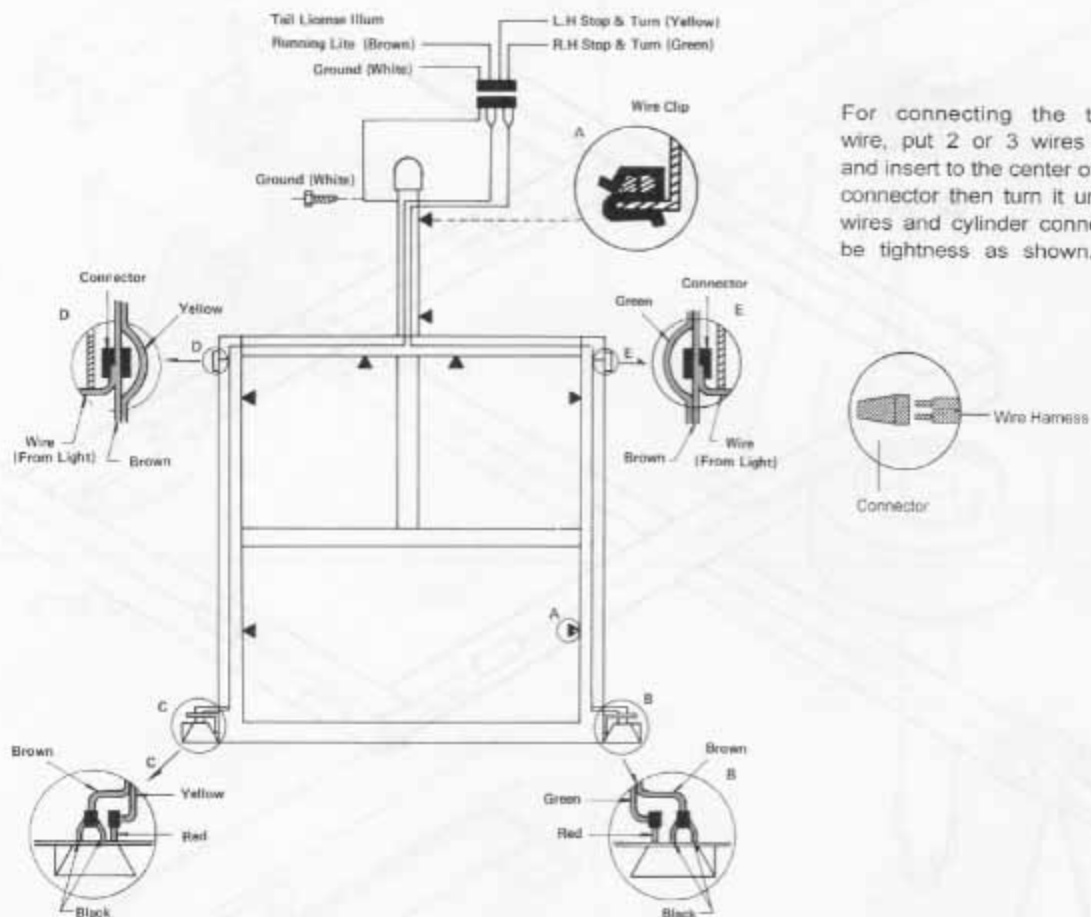

For connecting the tail light wire, put 2 or 3 wires together and insert to the center of cylinder connector then turn it until these wires and cylinder connector will be tightness as shown.

1. Attach white ground wire at plug end of wiring harness to the small hole in towbar with self tapping screw.
2. Leave about 18" of wire beyond the coupler and lay out wire on the inside of towbar and front cross-member as shown in the diagram. Push on the wire clips.
3. Connect the wire lead from the running lights to the brown wire on each side with the wire connector. Use pliers to squeeze the connector closed.
4. Push on wire clips to hold wires down the side rails of the trailer.
5. Cut yellow/brown and green/brown wires to appropriate lengths and strip ends of wires $\frac{3}{4}$ ".
6. Make taillight connections as per color code:

Left side

Trailer wire
Yellow
Brown

Tail Light
Red wire
Two black wires

Right side

Trailer Wire
Green
Brown

Tail Light
Red wire
Two black wires

AVAILABLE ACCESSORIES

- * Spare tire (Not included)
- * Spare tire holder (Not included)

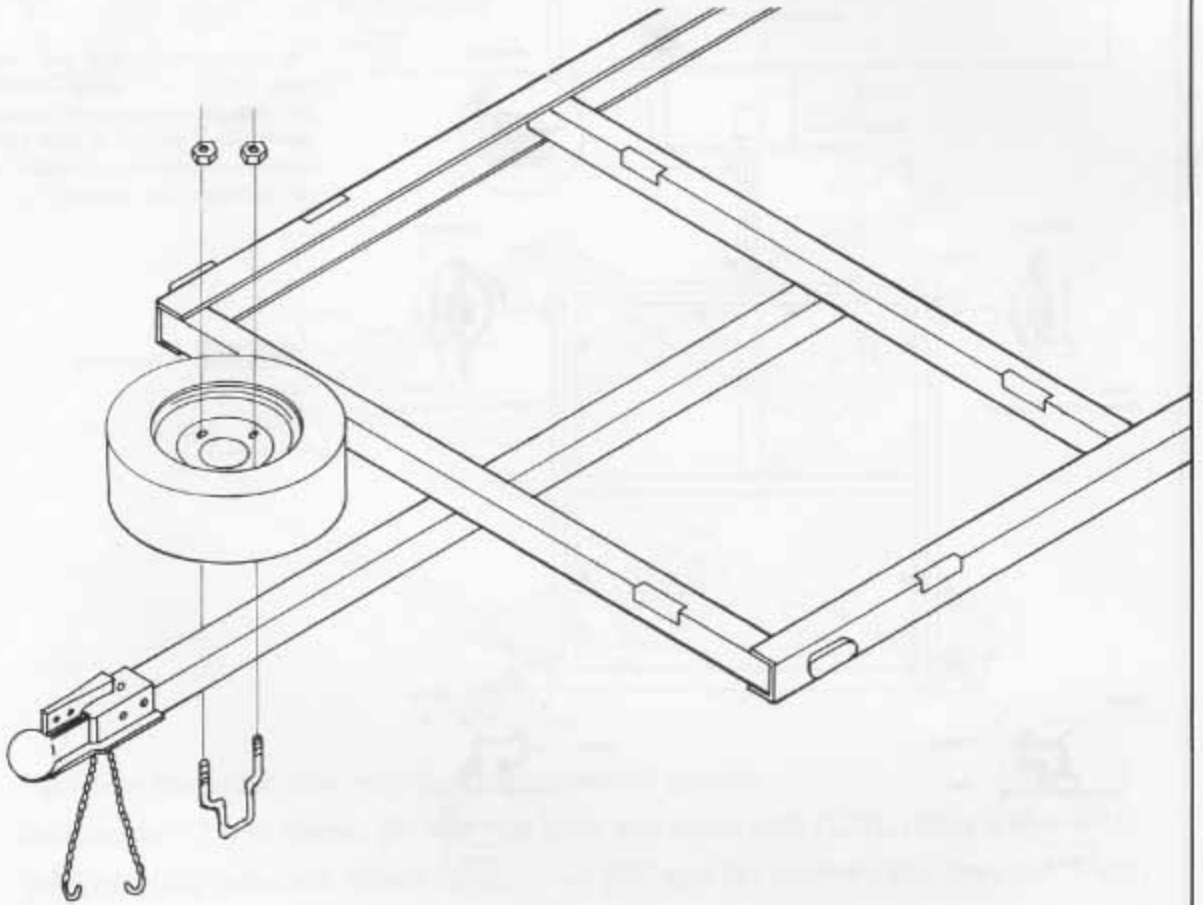

AVAILABLE ACCESSORIES

* Trailer Stand (Not included)

STEP 1

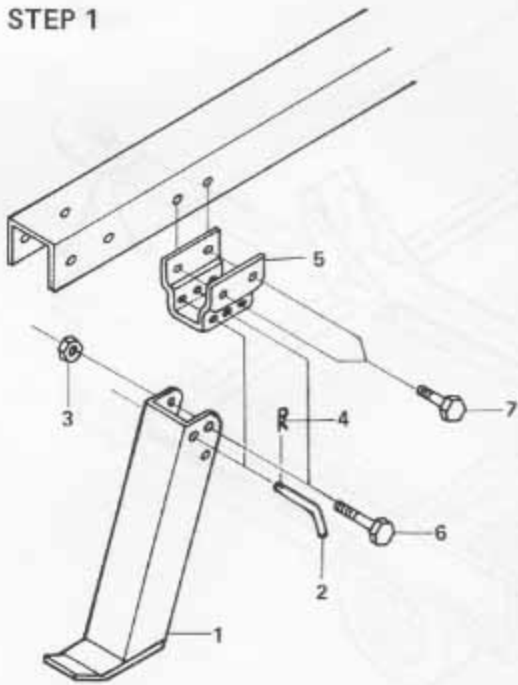

STEP 2

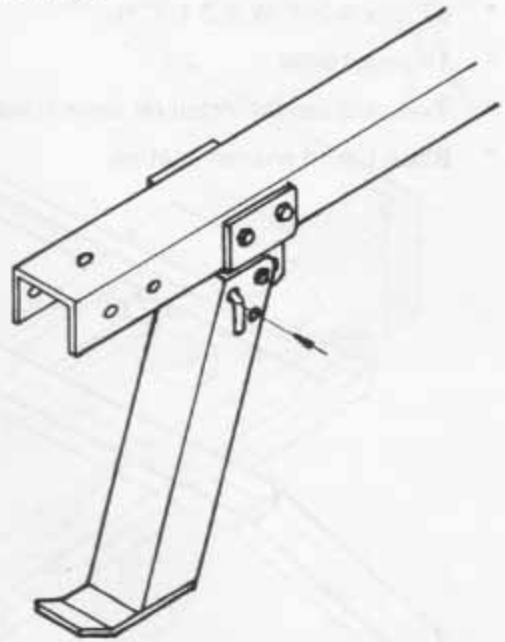

STEP 3

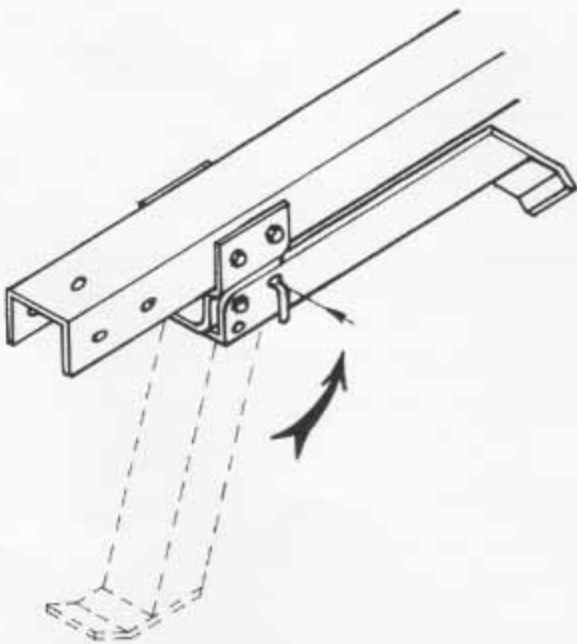

AVAILABLE ACCESSORIES

MOTORCYCLE RAIL (NOT INCLUDED)

- * 67" L x 4-3/4" W x 2-1/4" H.
- * 14 gauge steel.
- * Two rails can be install on basic trailer.
- * Black baked enamel coating.



BOX KIT (NOT INCLUDED)

- * 47''L x 40''W x 10''H.
- * With tail gate.
- * Steel.

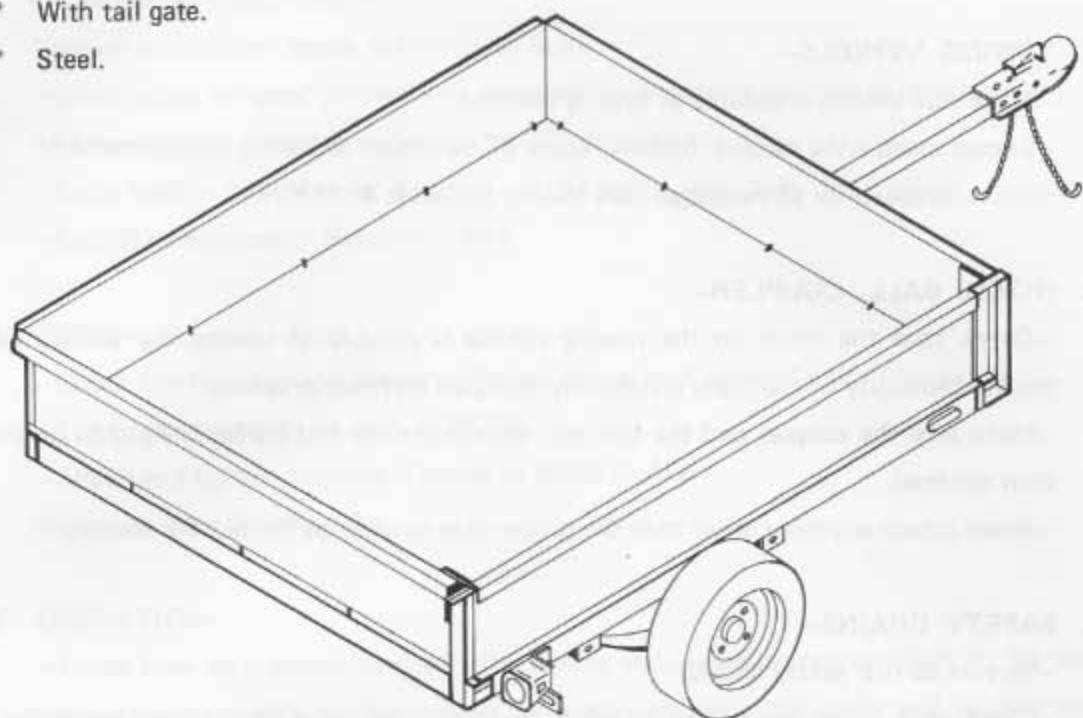

SAFE USE AND OPERATION RULES

1. TOWING VEHICLE—

- Make sure vehicle is capable of towing the load.
- Excess speed is the second highest cause of car-trailer accidents. Recommended maximum speed for all passenger cars towing trailers is 45 M.P.H.

2. HITCH, BALL, COUPLER—

- Check that the hitch on the towing vehicle is capable of towing the trailer. The towing capability of the hitch is normally stamped on hitch drawbar.
- Make sure the coupler and the ball are the same sizes and are rated equal to or greater than the load.
- Never attach anything other than the proper size coupler to the ball for towing.

3. SAFETY CHAINS—

- Be sure to use safety chains.
- Check that safety chains are attached to towing vehicle with the same length for each side.
- Do not allow chains to drag on ground.

4. LOADING—

- Never overload trailer. Maximum load is 1060 pounds.
- Load trailer evenly from side to side with 60% of the load forward of the axle. It is important that the tongue be pressing down on the hitch, but not exceeding a downward force of 106 pounds.
- Reduce weight in car trunk and rear seat areas by amount of tongue weight of your trailer.
- It is against the law to carry passengers in the back of any trailer.

5. LIGHTING—

—Check lighting before each use and every 100 miles to be sure stop, tail and turn signals are working properly.

Replace any broken lenses, reflectors or bulbs.

—Check wires for good connections and possible fraying or wearing of insulation.

—Bulbs supplied with this trailer are for 12 volt system.

—Bulbs used in tail light are: Number — 1157 (Stop and Tail), 1895 (Side).

—Bulb for clearance is: Number — 194.

6. TIRES—

—Check tire for wear and proper inflation before each use and every 100 miles.

—Tire pressure should be kept at 60 PSI.

—Check and tighten lug nuts. Torque to 85-90 ft. lbs.

Retorque after first 50 miles.

7. OPERATION—

—Know how to properly control your towing vehicle-trailer combination on the highway under all conditions. Remember the loaded weight of the trailer will increase your braking and stopping distances appreciably.

—When towing a trailer over long distances, stop and check tightness of all connections lights and running gear every 100 miles.

—Carry emergency flares and fire extinguisher if required for operation in your state.

—It is desirable to carry extra bulbs and fuses if you are towing the trailer at night over any great distances.

8. MAINTENANCE—

—Check and maintain the trailer, coupler, ball and hitch before each use and every 200 miles.

—Inspect hitch and ball for, damage in every day use.

—Ball or hitch can be damaged in parking, hitting curbs, dragging when crossing ditches or railroad tracks.

—Check safety chains for wear, and do not allow safety chains to drag on ground.

—To prevent bearing damage, disassemble and repack wheel bearing with a good grade of wheel bearing grease every 2000-3000 miles or yearly.

—If you don't know how to repack wheel bearing, take your trailer to a garage for advice.

SPECIAL NOTICE FOR COUPLER

Only use a 1-7/8" ball hitch on your towing vehicle. Pull trigger and lift handle. Place coupler over trailer hitch ball and push down on handle until trigger locks in slot.

Pull up and down on the coupler to insure the ball is fitting snug in the coupler. There should be no play between the ball and coupler. If there is play, tighten the adjustment nut until no play is present. If the nut is too tight, the handle will not close.

NOTE: To reduce friction between the ball hitch and coupler, apply a layer of multi-purpose lithium grease over ball hitch. Wipe off excess grease when not in use to avoid staining clothes.

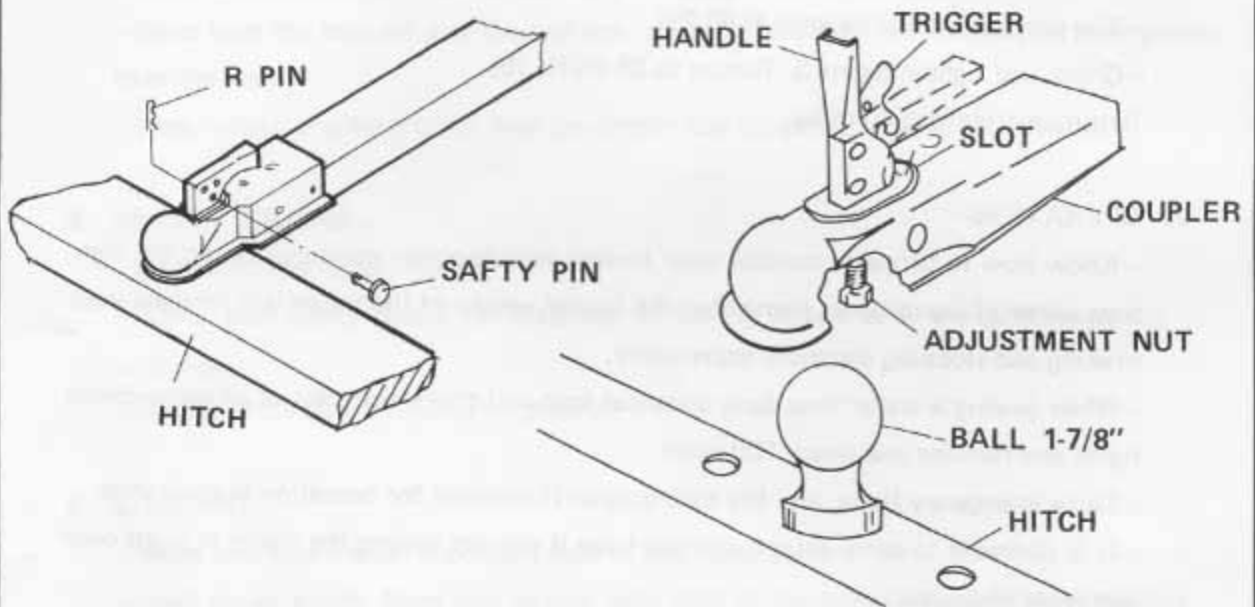

IMPORTANT

Please apply the attached "STICKER NOTICE" to the towbar as shown.

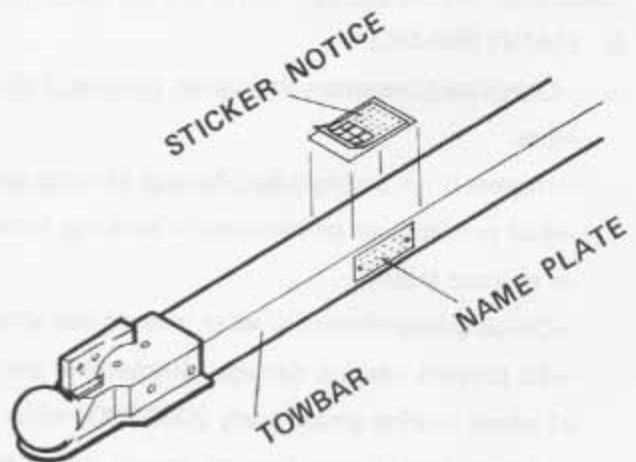

IMPORTANT

The purpose of following notices are to give you tips on safe use and operation of your utility trailer.

1. Please read the instructions carefully and follow them step-by-step for easy assembly. Please maintain these instructions in your files.
2. Please double check the assembling step-by-step, be sure each is followed.
3. Be sure to apply for license as required.
4. Before using, please inspect your trailer.
5. Do not remove the sticker notice from the towbar.

Notice:

- * Re-fill grease on bearing after every 3,000 miles of use.
- * Keep tire pressure at 60 p.s.i. cold.
- * Please insure you comply with the following before using your trailer.
 1. Tighten U-bolt.
 2. Tighten lug nut.
 3. Tighten trigger lock on coupler.
 4. Hook up safety chain.
 5. Trailer load should not exceed its 1060 lbs capacity and should be properly secured.
 6. Trailer load size should not exceed trailer's bed board size.

Correct way to load your trailer

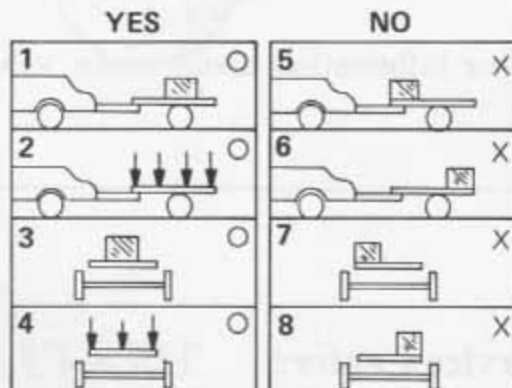

Long Chih Ind. Co., Ltd
P.O. Box 22793, Taipei, Taiwan, R.O.C.

Reporting Safety Defects

If you believe that your vehicle has a defect which could cause a crash or could cause injury or death, you should immediately inform the National Highway Traffic Safety Administration (NHTSA) in addition to notifying Long Chih Ind. Co., Ltd.

If NHTS receives similar complaints, it may open an investigation, and if it finds that a safety defect exists in a group of vehicles, it may order a recall and remedy campaign. However, NHTSA cannot become involved in any individual problems between you, your dealer, or Long Chih Ind. Co., Ltd.

To contact NHTSA you may either call the Auto Safety Hotline toll-free at 1-800-424-9393 (366-0123 in Washington, DC area) or write to:

NHTSA

U.S. DEPARTMENT of TRANSPORTATION

400 7th Street SW. 9NSA-11)

Washington, DC 20590

You can also obtain other information about motor vehicle safety from the hotline.

U.S.A. Customer Service Center:
Toll free: 1-800-576-7888