

# **Electric Drive Machine Operation & Safety Instructions**

## **SPECIFICATIONS**

**Model:** EDM-18  
**Part No:** 59224  
**Motor:** 1/2 Horsepower  
**RPM:** 18  
**Electric:** 115V - 8.8 amps  
**Torque:** 1245 in. lbs.

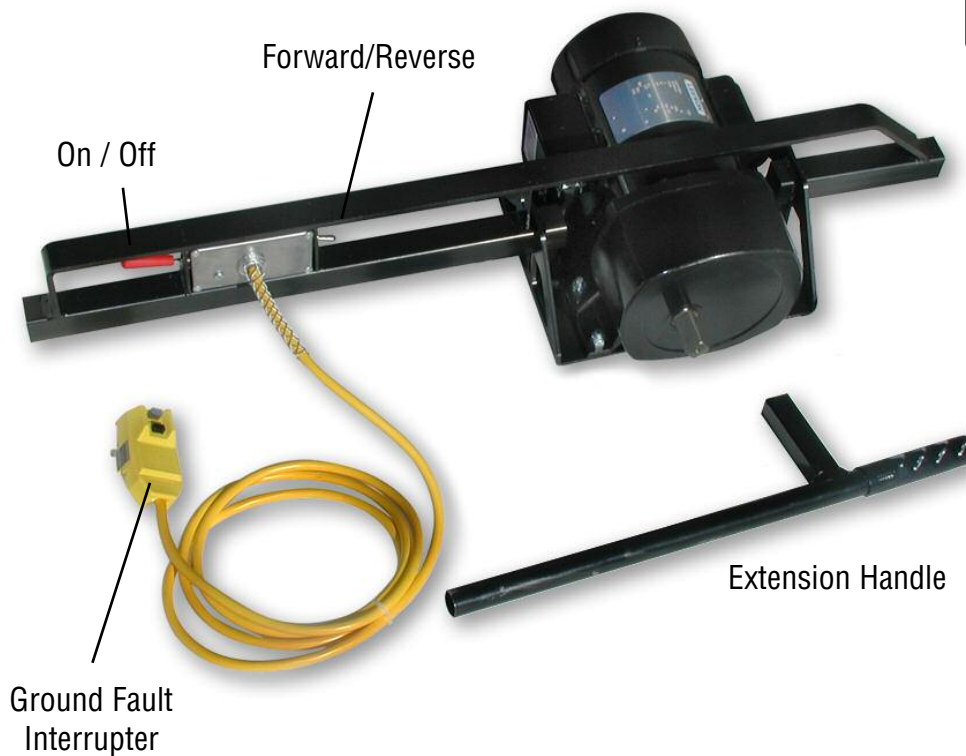

Earth Anchor Adaptor  
(Included)



Eye Anchor Adaptor  
(Optional)

## **Cautions and Warnings:**

- Before installation of any ground anchor, determine that the ground anchors to be installed will not be near any underground electrical cables, phone lines, water lines, sewer pipes, or gas lines. Failure to do so may result in serious injury or death
- The EDM is designed for operation by two people.
- Do not allow the EDM to be wedged against the home or other solid objects, when operating the EDM.
- Electrical cord must be a minimum of 14-2 wire size w/ground up to 25 ft. of cord. Longer cords must be 12-2 wire size w/ground or lower.
- Never operate the EDM in wet or rainy conditions.
- Frayed or patched electrical cords should never be used with the EDM.
- Care should be taken to keep electrical cords away from anchors.
- Never operate drive machine without the GFI power cord. Damage to motor and injury to operator can result from bypassing the GFI.
- The GFI will shut off power when a ground fault is detected. The GFI will also shut off power when it detects low voltage or improper amps required to drive the motor. Many times the problem will be the use of an extension cord that is too long or is too light in gage.

Instructions #15391

**TIE DOWN ENGINEERING • 5901 Wheaton Drive • Atlanta GA, 30336**  
**www.tiedown.com • (404) 344-0000 • FAX (404) 349-0401**

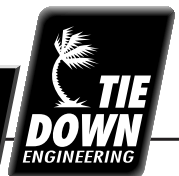

122105, D276

### Operating Instructions:

1. Attach adapter head to shaft of the EDM motor, tighten set screw.
2. Place extension handle in the end of the EDM if needed.
3. Place anchor head into adapter, line up anchor shaft with EDM shaft, for easier installation.
4. Flip forward/reverse switch to forward.
5. Place anchor tip in location where anchor is to be buried. Hold on/off switch to install.

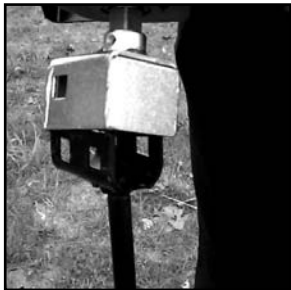

EDM comes complete with adapter head.



Adapter fits anchors and Soil Test Probe



Two man operation makes easy work of anchor installation

### Warranty Information

Extensive testing by TIE DOWN Employees and an outside engineering lab has found that the gear case on the Electric Drive Machine will not crack or break under normal use conditions.

### Normal use conditions are two people holding the drive machine.

Testing has shown that when extremely hard ground is encountered, two average size adults cannot hold the drive machine in place when the anchor ceases to turn. The installers are turned in a circle when the anchor cannot be turned in the ground.

Cracking and breaking of the gear case is usually accomplished by wedging one or both ends of the drive machine against a home or other stationary object. The gear case can also be cracked or broken when the machine is dropped or thrown to the ground.

When the installer encounters difficult ground, follow anchor installation instructions found in our Anchor Installation Manual. This involves pre-digging part of the hole where the anchor will be installed.

Since we now have tests results from an outside testing facility, warranty claims on cracked or broken gear cases will not be honored unless there is an obvious indicator that there was a manufacturing defect in the product. If you do not agree with this policy, please return the drive machine to the place of purchase for a refund before it is used.

Every Model EDM-18 Anchor Drive Machine manufactured by Tie Down Engineering is warranted against all defects in material or workmanship for 90 days from date of purchase. To validate your warranty, complete the card enclosed with the drive machine and return to Tie Down within 10 days of purchase. Should the machine need service within the 90 day period, Please call Tie Down and request a RMA, ship the EDM to Tie Down freight pre-paid, Return freight will be at no charge to you.

# Anchor Drive Machine

## Replacement Parts List

### SPECIFICATIONS

**Model:** EDM-18  
**Part No:** 59224  
**Motor:** 1/2 Horsepower  
**RPM:** 18  
**Electric:** 115V - 8.8 amps  
**Torque:** 1245 in. lbs.

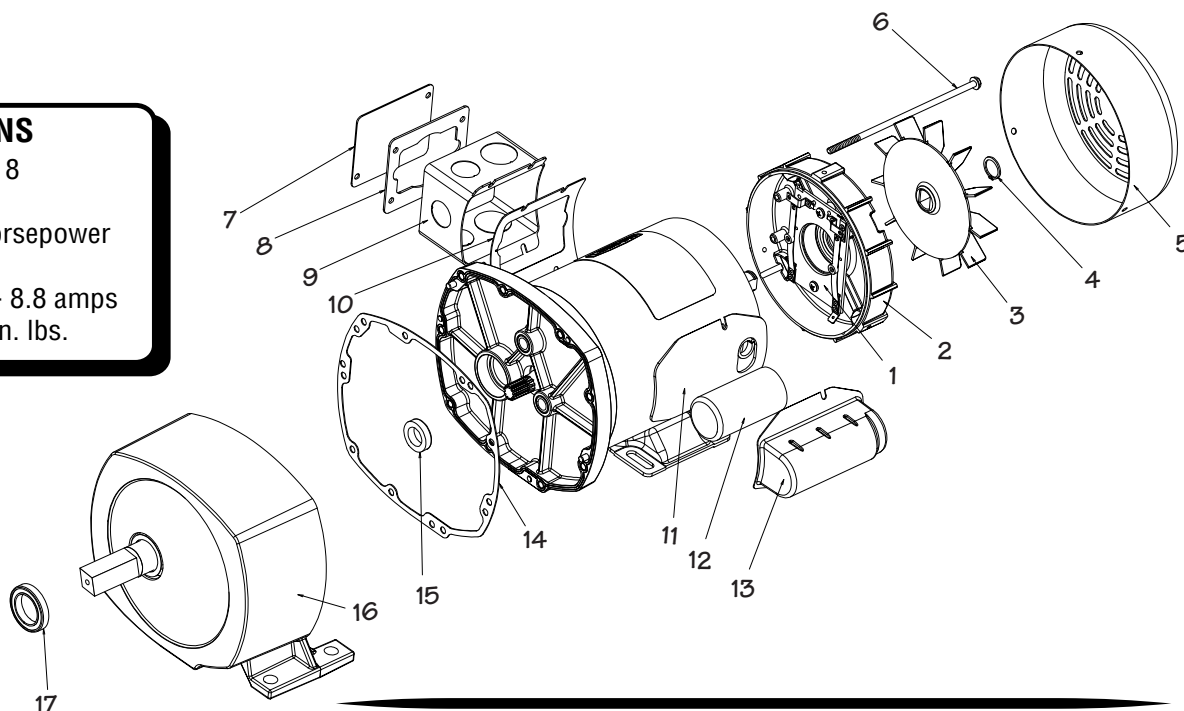

Item #	Part #	Description	Quantity
1	12529	Stationary Switch	1
2	12528	Endbell - TEFC	1
3	12526	External Fan	1
4	12546	Retaining Ring	1
5	12527	Fan Guard	1
6	12538	10-32 T-Bolt	4
7	12536	Conduit Box Cover	1
8	12551	Conduit Box Cover Gasket	1
9	12537	Conduit Box	1
10	12539	Conduit Box Gasket	1
11	12554	Capacitor Case Gasket	1
12	12533	Capacitor	1
13	12534	Capacitor Case	1
14	12553	Gasket	1
15	12548	Input Seal	1
16	12558	Gearbox Assembly	1
17	12549	Output Seal	1
18	12530	Full Motor Assembly (1-17)	1

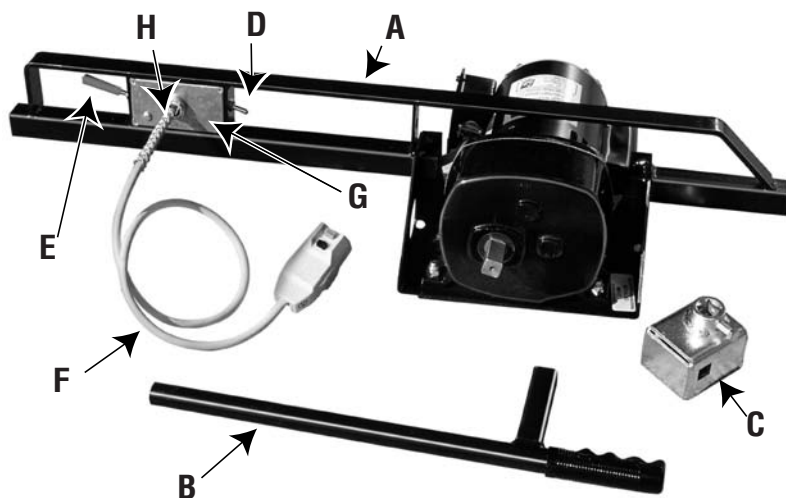

Ref#	Description	Part #	Qty.
A	Drive Machine Frame	59238	1
B	Drive Machine Handle	48911	1
C	Earth Anchor Adaptor	59205	1
	Eye Anchor Adaptor	59206	Optional
D	Forward & Reverse Switch	1DMFR	1
E	On/Off Switch	IDMOF	1
F	GFI Power Cord	12540	1
G	Bus Box	IDBWF	1
H	Cable Protector	IDMCC	1

**TIE DOWN ENGINEERING • 5901 Wheaton Drive • Atlanta GA, 30336**  
**www.tiedown.com • (404) 344-0000 • FAX (404) 349-0401**



101006, D840

## Conduit Box Wiring Diagram

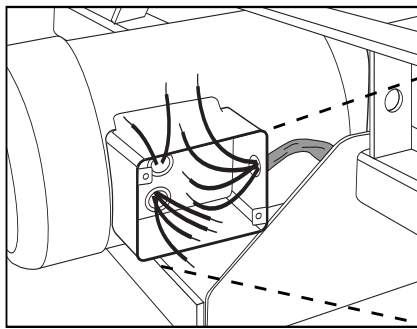

Motor Wiring

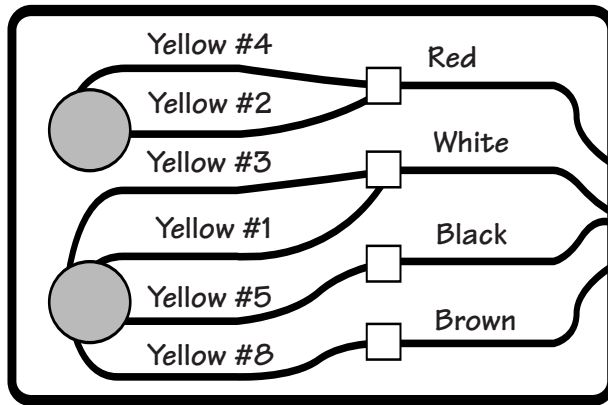

Power Cord Wiring

#4 & 2 (Red) • #3 & #1 (White) • #5 (Black) • #8 (Brown)

## Switch Box Wiring Diagram

