



# 21-GALLON AIR COMPRESSOR OWNER'S MANUAL



 **WARNING**

Read carefully and understand **RULES FOR SAFE OPERATION** and instructions before operating. Failure to follow the safety rules and other basic safety precautions may result in serious personal injury.

ITEM#123012

Thank you very much for choosing a NORTHERN TOOL + EQUIPMENT CO., INC., Product! For future reference, please complete the owner's record below:

Model: \_\_\_\_\_ Purchase Date: \_\_\_\_\_

Save the receipt, warranty and these instructions. It is important that you read the entire manual to become familiar with this product before you begin using it.

This machine is designed for certain applications only. Northern Tool + Equipment strongly recommends this machine is not modified and/or used for any application other than that for which it was designed. If you have any questions relative to a particular application, DO NOT use the machine until you have first contacted Northern Tool + Equipment to determine if it can or should be performed on the product.

For technical questions and replacement parts, please call 1-800-222-5381.

## TECHNICAL SPECIFICATIONS

Working Air Pressure	90 PSI
Maximum Air Pressure	115 PSI with Auto Shut-Off
Air Tank Capacity	21 Gallons
Air Flow Capacity	4.25 CFM at 40 PSI
	3.56 CFM at 90 PSI
Motor	3 HP Working
	120 Volt / 60Hz
Pump Stage	Single
Air Outlet Size	1/4" 18 NPT
Shipping Weight	152 Lbs.

## GENERAL SAFETY RULES

 **WARNING: Read and understand all instructions.** Failure to follow all instructions listed below may result in electric shock, fire and/or serious injury.

 **WARNING: The warnings, cautions, and instructions discussed in this instruction manual cannot cover all possible conditions or situations that could occur. It must be understood by the operator that common sense and caution are factors which cannot be built into this product, but must be supplied by the operator.**

 **WARNING: HIGH PRESSURE AIR.** Bypassing, modifying or removing safety/relief valves can cause serious injury or death. Do not bypass, modify or remove safety/relief valves. Do not direct air stream at body. Rusted tanks can cause explosion and severe injury or death. Drain tank daily or after each use. Drain valve located at bottom of tank.

 **CAUTION: RISK OF BURSTING.** Use only suitable air handling parts acceptable for pressure of not less than the maximum allowable working pressure of the machine.

 **DANGER: RISK TO BREATHING.** The compressed air from your compressor is not safe for breathing. The air stream may contain carbon monoxide, toxic vapors or other contaminants. Never inhale air from the compressor either directly or from a breathing device connected to the compressor.

## SAVE THESE INSTRUCTIONS

### WORK AREA

- **Keep work area clean**, free of clutter and well lit. Cluttered and dark work areas can cause accidents.
- **Do not use your compressor where there is a risk of causing a fire or an explosion;** e.g. in the presence of flammable liquids, gasses, or dust.

- **Keep children and bystanders** away while operating a compressor. Distractions can cause you to lose control, so visitors should remain at a safe distance from the work area.
- **Be aware of all power lines, electrical circuits,** water pipes and other mechanical hazards in your work area, particularly those hazards below the work surface hidden from the operator's view that may be unintentionally contacted and may cause personal harm or property damage.
- **Be alert of your surroundings.** Using compressors in confined work areas may put you dangerously close to cutting tools and rotating parts.

## ELECTRICAL SAFETY

 **WARNING:** Unqualified use and improper maintenance of this air compressor could result in serious personal injury. The following safety instructions should be operated to avoid any risk! Please read all of these instructions carefully and follow them.

 **WARNING!** Always check to ensure the power supply corresponds to the voltage on the rating plate.

- **Do not abuse the cord.** Never move a compressor by its power cord, or yank cord or extension cord from the receptacle. Keep power and extension cords away from heat, oil, sharp edges or moving parts. Replace damaged cords immediately. Damaged cords may cause a fire and increase the risk of electric shock.
- **Grounded tools** must be plugged into an outlet properly installed and grounded in accordance with all codes and ordinances. Never remove the grounding prong or modify the plug in any way. Do not use any adapter plugs. Check with a qualified electrician if you are in doubt as to whether the outlet is properly grounded.
- **Double insulated tools** are equipped with a polarized plug (one blade is wider than the other). This plug will fit in a polarized outlet only one way. If the plug does not fit fully in the outlet, reverse the plug. If it still doesn't fit, contact a qualified electrician to install a polarized outlet. Do not change the plug in any way.
- **Avoid body contact** with grounded surfaces such as pipes, radiators, ranges, and refrigerators. There is an increase risk of electric shock if your body is grounded.
- **Do not expose** compressor to rain or wet conditions. Water entering a motor will increase the risk of electric shock.
- **Do not let your fingers** touch the terminals of plug when installing to or removing from the outlet.
- **Ground fault circuit interrupters.** If work area is not equipped with a permanently installed Ground Fault Circuit Interrupter outlet (GFCI), use a plug-in GFCI between compressor and power receptacle.

## PERSONAL SAFETY

- **Stay alert,** watch what you are doing and use common sense when operating a compressor. Do not use a compressor while you are tired or under the influence of drugs, alcohol or medication. A moment of inattention while operating a compressor may result in serious personal injury.
- **Dress properly.** Do not wear loose clothing, dangling objects, or jewelry. Keep your hair, clothing and gloves away from moving parts. Loose clothes, jewelry or long hair can be caught in moving parts. Air vents often cover moving parts and should be avoided.
- **Use safety apparel and equipment.** Use ANSI-approved safety goggles or safety glasses with side shields which comply with current national standards, or when needed, a face shield. Use a dust mask in dusty work conditions. This applies to all persons in the work area. Also use non-skid safety shoes, hard hat, gloves, dust collection systems, and hearing protection when appropriate.
- **Avoid accidental starting.** Ensure the switch is in the off position before plugging tool into power outlet. In the event of a power failure, while a compressor is being used, turn the switch off to prevent surprise starting when power is restored.
- **Do not overreach.** Keep proper footing and balance at all times.

- **Remove adjusting keys or wrenches** before connecting to the power supply or turning on the tool. A wrench or key that is left attached to a rotating part of the tool may result in personal injury.

## TOOL USE AND CARE

- **Never use a compressor** with a malfunctioning switch. Any **compressor** that cannot be controlled with the switch is dangerous and must be repaired by an authorized service representative before using.
- **Disconnect power** from compressor and place the switch in the locked or off position before servicing, adjusting, installing accessories or attachments, or storing. Such preventive safety measures reduce the risk of starting the **compressor** accidentally.
- **Secure work** with clamps or a vise instead of your hand to hold work when practical. This safety precaution allows for proper tool operation using both hands.
- **Store idle compressor.** When a compressor is not in use, store them in a dry, secure place out of the reach of children. Inspect the compressor for good working condition prior to storage and before re-use.
- **Use only accessories that are recommended** by the manufacturer for your model. Accessories that may be suitable for one compressor may create a risk of injury when used on another compressor.
- **Never leave compressor** running unattended.
- **The motor is thermally protected** and will automatically shut off when it becomes overheated. Turn off the switch and start the compressor again after the motor cools.

## SPECIFIC PRODUCT PRECAUTIONS

**⚠ WARNING:** Make sure to fill the Air Compressor with a premium quality, 30W on-detergent oil before each use. Running the Air Compressor with no oil or low oil will cause damage to the equipment. **Note:** The oil reservoir has an optimal capacity of 30 ounces of oil.

1. **When checking the oil level:** Make sure to unscrew (do not pull) the Dip Stick out.
2. **Make sure all tools and equipment used with the air compressor are rated to appropriate capacity.** Do not use any tool or that does not operate from 0 to 115 PSI.
3. **Drain the compressor every day.** Do not allow moisture to build up inside the Air Compressor. (See "INSPECTION, MAINTENANCE, AND CLEANING" section of this Manual.)
4. **Avoid injuries:** **Never** direct the Air Flow Valve at people or animals.
5. **Do not alter or remove** the factory-sealed pressure release valve.
6. **Open water drain valve** so that not more than four threads are exposed.
7. **An extension cord must never be used with this item.** Connecting this item to an outlet through an extension cord may cause electrical damage to the motor and could present a fire hazard.

**⚠ WARNING:** This compressor may require a dedicated electrical circuit. The amperage draw under a full load combined with use of any other item may overload your circuit

**⚠ WARNING:** People with pacemakers should consult their physician(s) before using this product. Operation of electrical equipment in close proximity to a heart pacemaker could cause interference to or failure of the pacemaker.

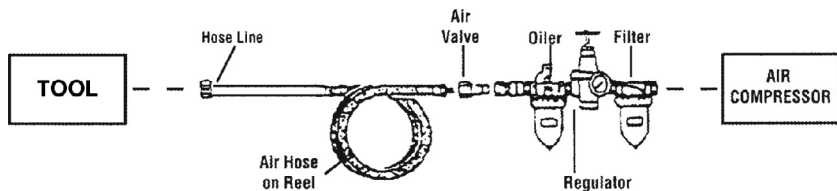

FIG. 1

**NOTE: To extend the life of your air equipment,** it is recommended to install an oiler and water filter in series with the Air Output Line of the Air Compressor (See Figure 1).

## GROUNDING INSTRUCTIONS

This product must be grounded. In the event of an electrical short circuit, grounding reduces the risk of electric shock by providing an escape wire for the electric current. This product is equipped with a cord having a grounding wire for with an appropriate grounding plug. The plug must be plugged into an outlet that is properly installed and grounded in accordance with all local codes and ordinances.

**⚠ WARNING:** Improper installation of the grounding plug is able to result in a risk of electric shock. When repair or replacement of the cord or plug is required, do not connect the grounding wire to either flat blade terminal. The wire with insulation having an outer surface that is green with or without yellow stripes is the grounding wire.

Substitution of the signal word "DANGER" for "WARNING" is not prohibition when the risk associated with the product is such that a situation exists which if not avoided will result in death or serious injury.

Check with a qualified electrician or serviceman when the grounding instruction are not completely understood, or when in doubt as to whether the product is properly grounded. Do not modify the plug provided; if it does not fit the outlet, have the proper outlet installed by a qualified electrician.

This production is for use on a nominal rating more than 120V (or "This product is rated more than 15A and is for use on a circuit having a nominal rating of 120V") and is factory-equipped with a specific electric cord and plug for connection to a proper electric circuit. Only connect the product to an outlet having the same configuration as the plug. Do not use an adapter with this product. When the product must be reconnected for use on a different type of electric circuit, the reconnection shall be made by qualified service personnel.

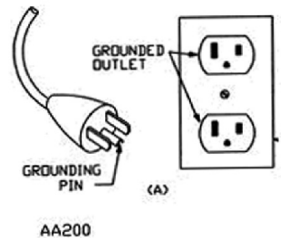

## OPERATING INSTRUCTIONS

### To Check The Oil Level:

1. The Oil Window is used to determine if oil is needed. The oil level should always be at the maximum level (red line on the Oil Window).
2. If necessary, add a *premium quality, 30W, non-detergent oil* into the Oil Fill Hole until the level of oil reaches the maximum level as indicated on the Oil Window (20B). The optimal capacity of the oil reservoir is 30 ounces. **Do not overfill.** Then thread the Dip Stick back into the Oil Fill Hole, being careful not to strip the plastic threads.

### To Turn The Air Compressor On:

1. Check to make sure the Water Drain Valve is fully closed.
2. Turn the Air Flow Valve to its "OFF" position.
3. Connect the air hose (not provided) to the Air Flow Valve of the Air Compressor. Then, connect the other end of the air hose to the pneumatic tool (not provided) that is to be used.
4. **Note:** Always plug the Power Cord of the Air Compressor into a 115 V electrical source (+/-10% maximum variation).
5. Rotate the "ON/OFF" Power Switch to the horizontal position to turn the Air Compressor **on.** (Rotate the "ON/OFF" Power Switch to the vertical position to turn the Air Compressor **off.**)
6. Allow sufficient time for the Tank Pressure Gauge to indicate **80 PSI** before using the Air Compressor.
7. Turn the Air Flow Valve to its "ON" position to allow air to the pneumatic tool.

**NOTE:** With the Air Compressor turned on, the operation is automatic and under the control of the automatic switches inside the box under the Power Switch.

 **WARNING:** Never open the power switch box or adjust the controls within.

***To Adjust The Air Output To The Pneumatic Tool:***

1. When adjusting the air pressure being forwarded to the pneumatic tool, you will need to compare the pressure readings of both the Tank Pressure Gauge and the Tool Pressure Gauge. The reading on the Tank Pressure Gauge dictates the maximum/minimum air pressure at which the Tool Pressure Gauge may also be set.
2. With the Air Compressor running, and the air hose and pneumatic tool hooked up to the Air Compressor, pull up on the Tool Pressure Adjuster. Turn the Tool Pressure Adjuster **clockwise to increase** the air output to the tool, up to the working air pressure (115 PSI) as indicated on the Tank Pressure Gauge.
3. Turn the Tool Pressure Adjuster **counterclockwise to decrease** the air output to the tool, down to the minimum rated pressure (0 PSI) as indicated on the Tank Pressure Gauge.

***To Use The Tank Pressure Relief Valve:***

1. The Tank Pressure Relief Valve Ring is used when decompression is needed quickly and efficiently.
2. To decompress the Air Tank pressure, rotate the "ON/OFF" Power Switch up to the vertical position to turn off the Air Compressor.
3. Pull out on the Tank Pressure Relief Valve Ring to immediately release air pressure in the Air Tank.

***To Empty Air And Condensation From The Tank:***

1. The Water Drain Valve is located underneath the Air Tank, and should be used daily to release all trapped moisture through this valve. The Water Drain Valve will also eliminate condensation that may cause Air Tank corrosion.

 **WARNING:** Do not open the Water Drain Valve so that more than four threads are showing.

2. Rotate the "ON/OFF" Power Switch up to the vertical position to turn off the Air Compressor. Then, unplug the Air Compressor's Power Cord from the electrical outlet.
3. Slowly and carefully unscrew (no more than four threads) the Water Drain Valve until the compressed air and condensation begins to be released from the Air Tank. Allow sufficient time for all of the air and condensation to escape from the Air Tank. Then, firmly retighten the Water Drain Valve.

**INSPECTION, MAINTENANCE AND CLEANING**

 **CAUTION:** Always disconnect the Air Compressor from its electrical supply source before performing any inspection, maintenance, or cleaning.

1. **Before each use**, inspect the general condition of the Air Compressor. Check all air fittings for leaks. Check for loose screws, misalignment or binding of moving parts, cracked or broken parts, damaged power cord and plug, and any other condition that may affect the safe operation of this tool. If abnormal noise or vibration occurs, immediately disconnect the Air Compressor from its electrical supply source and have the problem corrected before further use. **Do not use damaged equipment.**
2. **Daily:** Check the Air Compressor oil level. If necessary, fill with a premium quality, 30W non-detergent oil. **NOTE:** When checking the oil level, make sure to **unscrew** (do not pull) the Dip Stick.
3. Purge the Air Tank of all air and moisture to prevent corrosion.
4. **Every 100 Hours of use:** Clean the Air Filter with a mild solvent. Then, dry and reattach the Air Filter. **NOTE:** Replace the Air Filter if it is too dirty to properly clean.
5. **Every 500 Hours or 12 Months:** Replace the oil with new, high-quality, 30W non-detergent oil.
6. **To clean:** Wipe with a damp cloth, using a mild detergent or mild solvent.
7. **When storing:** Keep the Air Compressor in a clean, dry location.

## DIAGRAM & PARTS LIST

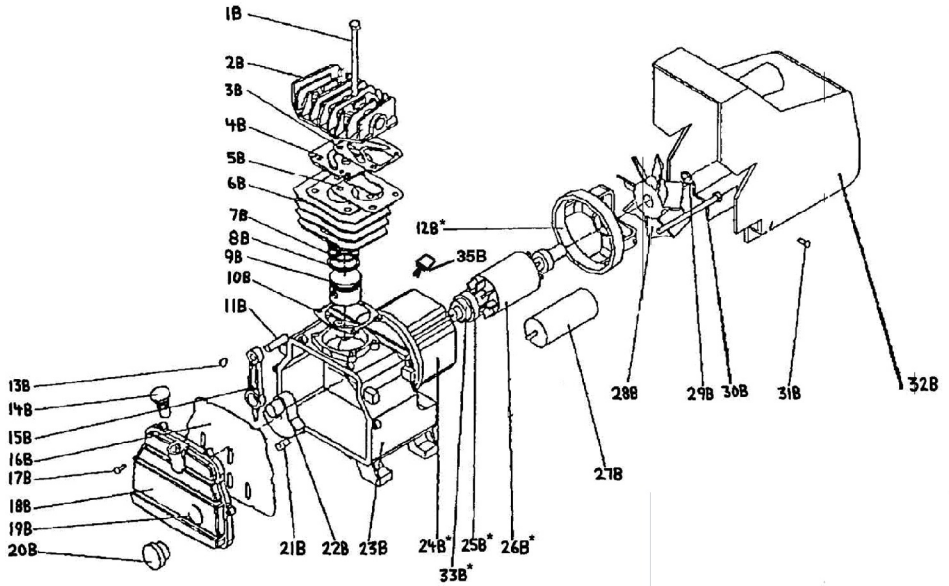

No.	Description	Q'ty
1B	Bolt	4
2B	Cylinder Case	1
3B	Gasket	1
4B	Valve Seat	1
5B	Gasket	1
6B	Cylinder	1
7B	Compression Ring	2
8B	Oil Scraping Ring	1
9B	Piston	1
10B	Gasket	1
11B	Piston Pin	1
12B	End Cover	1
13B	Crank shaft Retainer	2
14B	Dip Stick	1
15B	Connecting Rod	1
16B	Gasket	1
17B	Bolt	6
18B	Front Cover	1

No.	Description	Q'ty
19B	Gasket	1
20B	Oil Window	1
21B	Crankshaft Bolt	1
22B	Crankshaft	1
23B	Crankshaft Case	1
24B	Stator	1
25B	Bearing	2
26B	Armature	1
27B	Star Capacitor	1
28B	Radiating Fan Wheel	1
29B	Retainer Ring	1
30B	Bolt	4
31B	Screw	2
32B	Radiating Cover	1
33B	Seal Washer	1
34B	Motor Assembly	1
35B	Overload Switch	1



## **WARNING**

Some dust created by power sanding, sawing, grinding, drilling, and other construction activities contains chemicals known to the State of California to cause cancer, birth defects or other reproductive harm. Some examples of these chemicals are:

- Lead from lead-based paints
- Crystalline silica from bricks and cement and other masonry products, and arsenic and chromium from chemically-treated lumber.

Your risk from these exposures varies, depending on how often you do this type of work. To reduce your exposure to these chemicals: work in a well ventilated area, and work with approved safety equipment, such as those dust masks that are specially designed to filter out microscopic particles.



Northern Tool + Equipment Co.,  
2800 Southcross Drive West  
P.O. Box 1499 Burnsville, MN 55337-0499  
Made in China