

Minnesota **FATS**[®]

Congratulations on the purchase of your new DMI Sports Billiards table. Our products are designed and manufactured to give you years of game playing enjoyment.

KEEP BOX AND PACKING MATERIAL UNTIL TABLE HAS BEEN COMPLETELY ASSEMBLED.

ALL DAMAGE MUST BE REPORTED TO DMI WITHIN TEN DAYS OF RECEIPT.

If you have any problems with your new product,

PLEASE DO NOT RETURN IT TO THE STORE.

Please contact us:

1.800.399.4402

FAX: 215.283.9573

Please have your model number when inquiring about parts.

Or write to:

DMI Sports

Customer Service

375 Commerce Drive

Fort Washington PA, 19034

Please visit our web site at:

www.dmisports.com

When contacting DMI Sports, please provide your model number and item number (if applicable) if requesting a replacement part. Item numbers can be found inside this owners manual.

Your Model Number **MFT655**

Your model number is also located on the original carton. These instructions are also available online at: www.dmisports.com.

IMPORTANT!

Please Keep Your Instructions! (You will need your Model number should you need to contact us.) Before attempting assembly, please read through this instruction book to familiarize yourself with all the parts and assembly steps. We recommend that two adults assemble this table. Please refer to the Parts Identifier on the following page and be sure that all parts have been included. Although extremely rare, occasionally a part may be missing. If you are missing a part, or if you have any questions, please call our customer service department at 1.800.399.4402 Mon-Fri between the hours of 9:00am and 5:00pm E.S.T; or you can reach us at: www.dmisports.com.

Do not return the game to the store. Please contact us first at: 1.800.399.4402 or on our website at: www.dmisports.com.

TWO ADULTS ARE REQUIRED TO ASSEMBLE THIS BILLIARDS TABLE

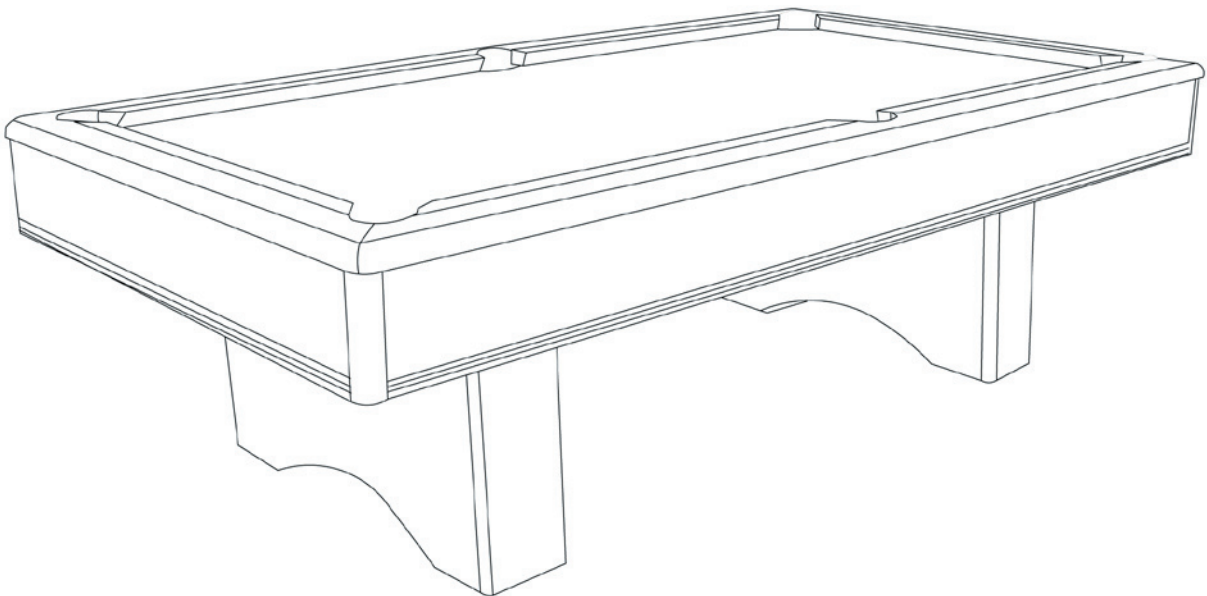





TOOLS REQUIRED FOR ASSEMBLY:



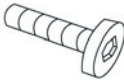

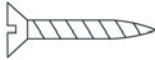

- Multi-Wrench- **Included**
- Phillips Head Screw Driver - **Not Included**
- Level recommended **Not Included**

PARTS IDENTIFIER

HARDWARE PARTS



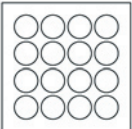



H1	Qty. 16	H2	Qty. 8	H3	Qty. 16	H4	Qty. 16
 1/4x1-1/2" Bolt RPMFT655-HKIT		 3/8x2-3/4" Bolt RPMFT655-HKIT		 1/4" x 15mm Washer RPMFT655-HKIT		 3/8" x 25mm Washer RPMFT655-HKIT	
H5	Qty. 8	H6	Qty. 16				
 3/8" Nut RPMFT655-HKIT		 2-1/2" Screw RPMFT655-HKIT					

ACCESSORY PARTS

A1	Qty. 1	A2	Qty. 1	A3	Qty. 2	A4	Qty. 1
 Wrench RPMFT-MWRENCH		 Allen Wrench RPMFT-AWRENCH		 Chalk MFA42405		 Triangle MFA40993	
A5	Qty. 1	A6	Qty. 1	A7	Qty. 2		
 Brush MFA42205		 Billiard Balls MFA41655		 Billiard Cues MFR40432			

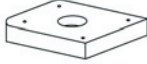
PARTS IDENTIFIER

ASSEMBLY PARTS

P1	Qty. 1	P2	Qty. 4	P3	Qty. 4	P4	Qty. 4
 Main Cabinet		 Leg Panel RPMFT655-LPANEL		 Leg Base A RPMFT655-LBASEA		 Leg Base B RPMFT655-LBASEB	
P5	Qty. 4	P6	Qty. 4				
 Leg RPMFT655-LEG		 Leg Leveler RPMFT655-LEV					

Note:

The assembly of this table is shown up-side-down.
 Please follow instructions based on the illustrations.

ASSEMBLY

STEP 1.

Begin assembly by attaching 2 (P5) Legs to 2 (P2) Leg Panels using Bolt (H1) and Washer (H3) as illustrated below in Fig. 2.

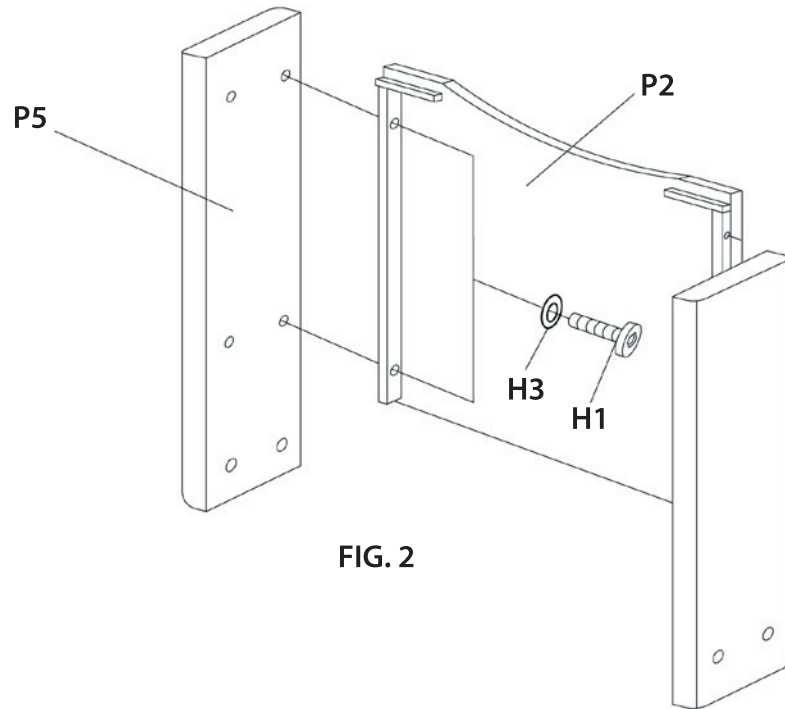

FIG. 2

STEP 2.

Continue the leg assembly by attaching Leg Bases (P3) and (P4) to two recently assembled leg assemblies using Screw (H6) as illustrated in Fig. 3. Once the bases are secured, attach the Leg Levelers (P6).

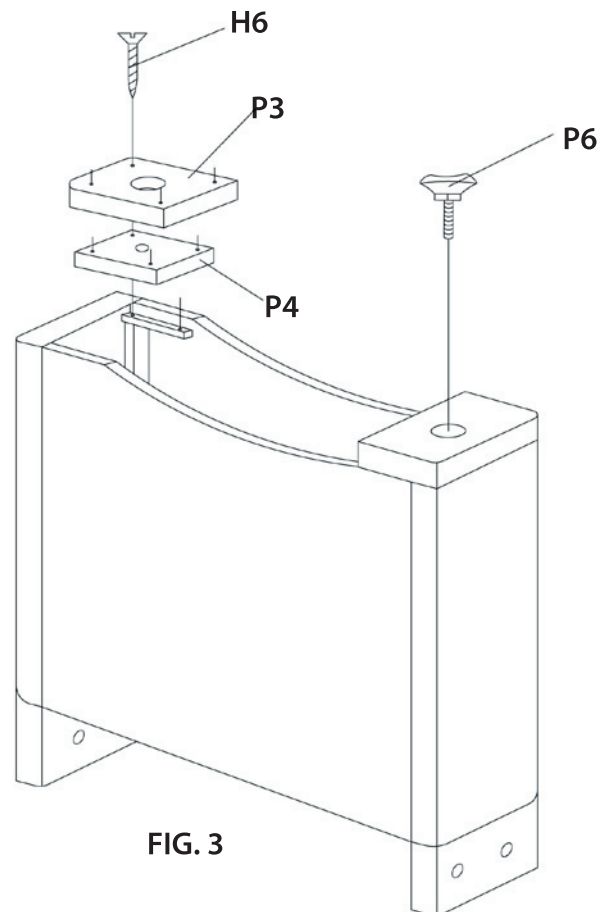

FIG. 3

ASSEMBLY

STEP 3.

Attach the connected leg assembly to the Main Cabinet (P1) as shown in Fig. 4 using Bolt (H2), Washer (H4) and Nut (H5).

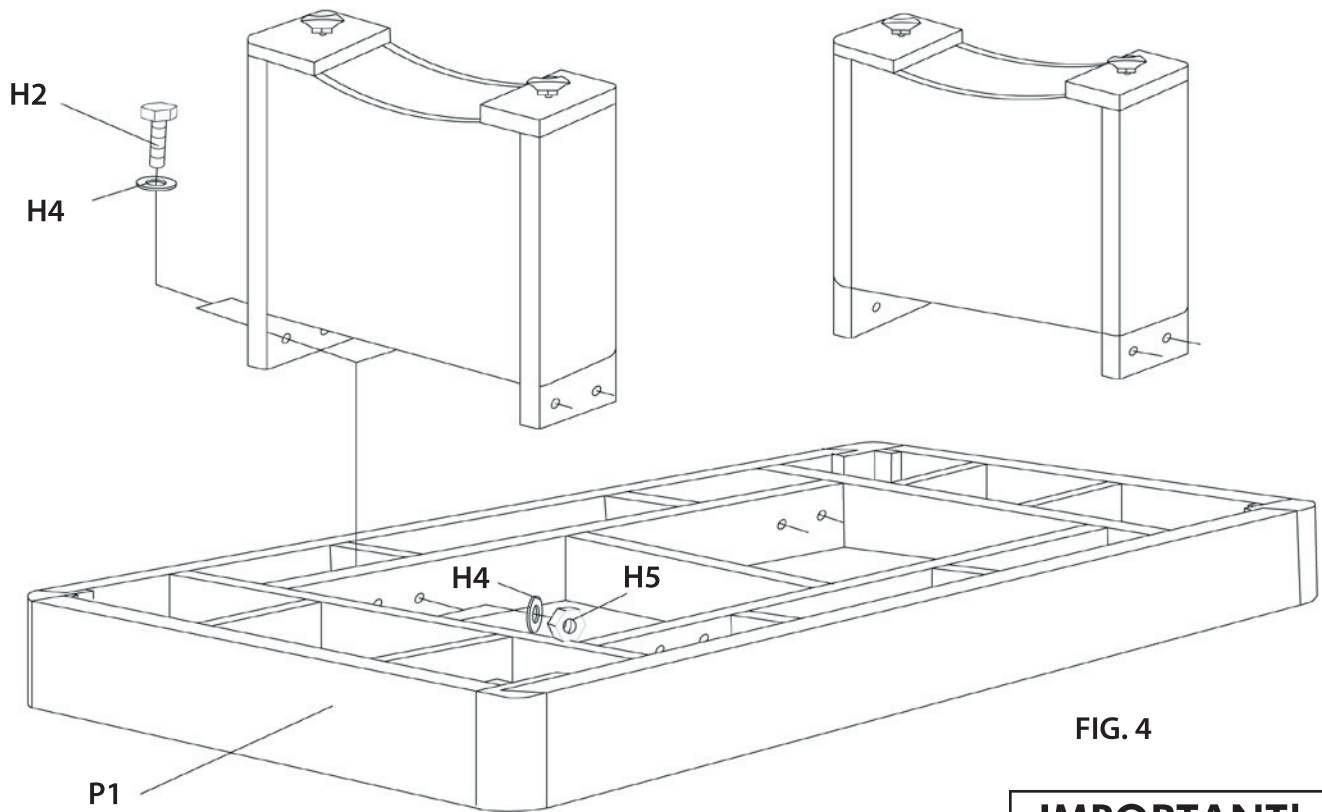
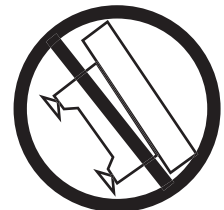

FIG. 4

IMPORTANT!

When turning the table over, be sure not to rest the weight of the table on the side of the legs. This could damage the leg levelers.



INSTRUCTIONS FOR LEVELING A POOL TABLE

- Assemble pool table according to the instructions, making sure levelers are screwed in completely, then turning one full turn out.
- Any type of level would be sufficient to perform this procedure. However, a two-foot level is recommended.
- Before leveling, make sure level is placed on the playing surface, not the rails.
- Level the ends between the corner pockets. Place the level on the playing surface between the two corner pockets and adjust the levelers in or out to position the bubble in the middle of the level.
- Repeat the step above to the opposite corner pockets.
- Next, level the length of the table. Place the level next to the side pocket and adjust the levelers in or out to position the bubble in the middle of the level.
- Repeat the step above to the opposite length of the table.
- Recheck both short ends to ensure bubble is in the middle on the level.
- Depending on the surface the pool table sits, especially deep pile carpeting, the pool table needs to settle for 24 hours. Recheck the level on each side of the table after 24 hours.
- These same instructions may be followed to level hockey and soccer table play surfaces as well.

