



# M11967K

ITEM NUMBER: 11967

SERIAL NUMBER: \_\_\_\_\_

## Owner's Manual

**Instructions for Assembly, Testing, Operation, Servicing, and Storage  
Log Splitter: Outdoor hydraulic machine that splits wood logs.**

### WARNING

**READ and UNDERSTAND this manual completely before using log splitter.**

All operators of this equipment must read and completely understand all safety information, operating instructions, maintenance and storage instructions. Failure to properly operate and maintain the log splitter could result in serious injury to the operator or bystanders from moving parts that can crush or cut, flying objects, burns, fire or explosion, escaping high pressure hydraulic fluid, or carbon monoxide poisoning. In particular, be aware of the following hazards:

#### Crush and Cut Hazards

Moving parts can crush and cut hands and fingers. Keep hands clear of endplate, wedge, and logs while splitting.

#### High Pressure Hydraulic Fluid Hazards

High fluid pressures and temperatures are developed in hydraulic log splitters. Hydraulic fluid escaping through even a pin-size hole opening can puncture skin and cause severe blood poisoning. Inspect hydraulic system regularly for possible leaks. Never check for leaks with your hand while the system is pressurized. Seek medical attention immediately if injured by escaping fluid.

#### Fire Hazards

- If your log splitter is intended for use near any ignitable forest, brush, or grassy covered land, the engine exhaust should be equipped with a spark arrestor. See the "Specifications" section of this manual to determine if your splitter already has a spark arrestor. If not equipped, call NorthStar Product Support for ordering information.
- Keep an ABC fire extinguisher with you that is rated for ordinary combustibles and flammable liquids.

### STOP!

**ADD OIL TO ENGINE BEFORE USING:** The engine is shipped without oil. DO NOT start log splitter without first adding oil. See instructions on p. 8.

**VERIFY HYDRAULIC OIL LEVEL:** Hydraulic reservoir is shipped with oil. Verify oil level is filled to "High" mark on hydraulic tank gauge before using. See instructions on pg. 8.

**PRIME THE PUMP:** The pump on your log splitter needs to be primed before use. Refer to Initial Setup section for instructions.

**Any Questions, Comments, Problems or Parts Orders**

***Call NorthStar Product Support 1-800-270-0810***

## Hazard Signal Word Definitions





	<p>This is the safety alert symbol. It is used to alert you to potential personal injury hazards. Obey all safety messages that follow this symbol to avoid possible injury or death.</p>
	<p>DANGER (red) indicates an imminently hazardous situation which, if not avoided, will result in death or serious injury.</p>
	<p>WARNING (orange) indicates a potentially hazardous situation which, if not avoided, could result in death or serious injury.</p>
	<p>CAUTION (yellow) indicates a potentially hazardous situation which, if not avoided, may result in minor or moderate injury.</p>
	<p>CAUTION (yellow) used without the safety alert symbol indicates a potentially hazardous situation which, if not avoided, may result in property damage.</p>

fig01453

# Table of Contents

About Your Log Splitter.....	4
Attention: All Rental Companies and Private Owners who loan this equipment to others! .....	4
Safety Label Locations .....	5
Machine Component Identification.....	7
Initial Unpacking and Set-Up.....	8
Connecting Battery to Engine .....	9
Moving and Towing to the Job Site .....	10
Before Each Use:	
Step One: Inspection / Maintenance.....	14
Step Two: Fueling .....	16
Step Three: Work Site Selection .....	17
Splitting Operation .....	18
Storage .....	24
Periodic Maintenance .....	25
Troubleshooting .....	26
Specifications .....	27
Parts Breakdown – Exploded View .....	28
Summary of Important Safety Information.....	30
Warranty Registration .....	36
California Proposition 65 Information .....	38

# About Your Log Splitter

Thank you for purchasing your NorthStar log splitter!

## **About Your Log Splitter:**

This log splitter is a machine designed to split wood logs using a hydraulically powered moving ram which pushes the log against a splitting wedge. The log splitter's gasoline engine is used to pressurize the hydraulic system.

This log splitter is designed to split logs *up to 30" long and 24" in diameter, lengthwise with the grain only*. The splitter features 1) a power log lift that assists in loading logs onto the beam for splitting, and 2) a splitting wedge that can be adjusted to split logs into either halves, or for larger logs, quarters.

The technical specifications for your log splitter are provided on p. 27 of this manual.

### **WARNING**

This log splitter uses a high-pressure hydraulic system to generate a very strong splitting force. **Read the manual completely** before using the machine to understand how to safely operate and maintain it.

Follow all safety precautions presented throughout this manual. A summary of important safety information can be found at the end of the manual.

**Contact NorthStar Product Support at 1-800-270-0810 for any questions about the appropriate use of this log splitter and/or optional accessories.**

### **Warranty Registration:**

Please fill out and submit the warranty registration so that we have your contact information for any future product literature or replacement parts you may need.

## **Attention: All Rental Companies and Private Owners who loan this equipment to others!**

*All persons to whom you rent/loan the log splitter must have access to and read this manual. Keep this owner's manual with the splitter at all times and advise all persons who will operate the machine to read it. You must also provide personal instruction on how to safely operate the splitter and remain available to answer any questions a renter/borrower might have.*

## Safety Label Locations

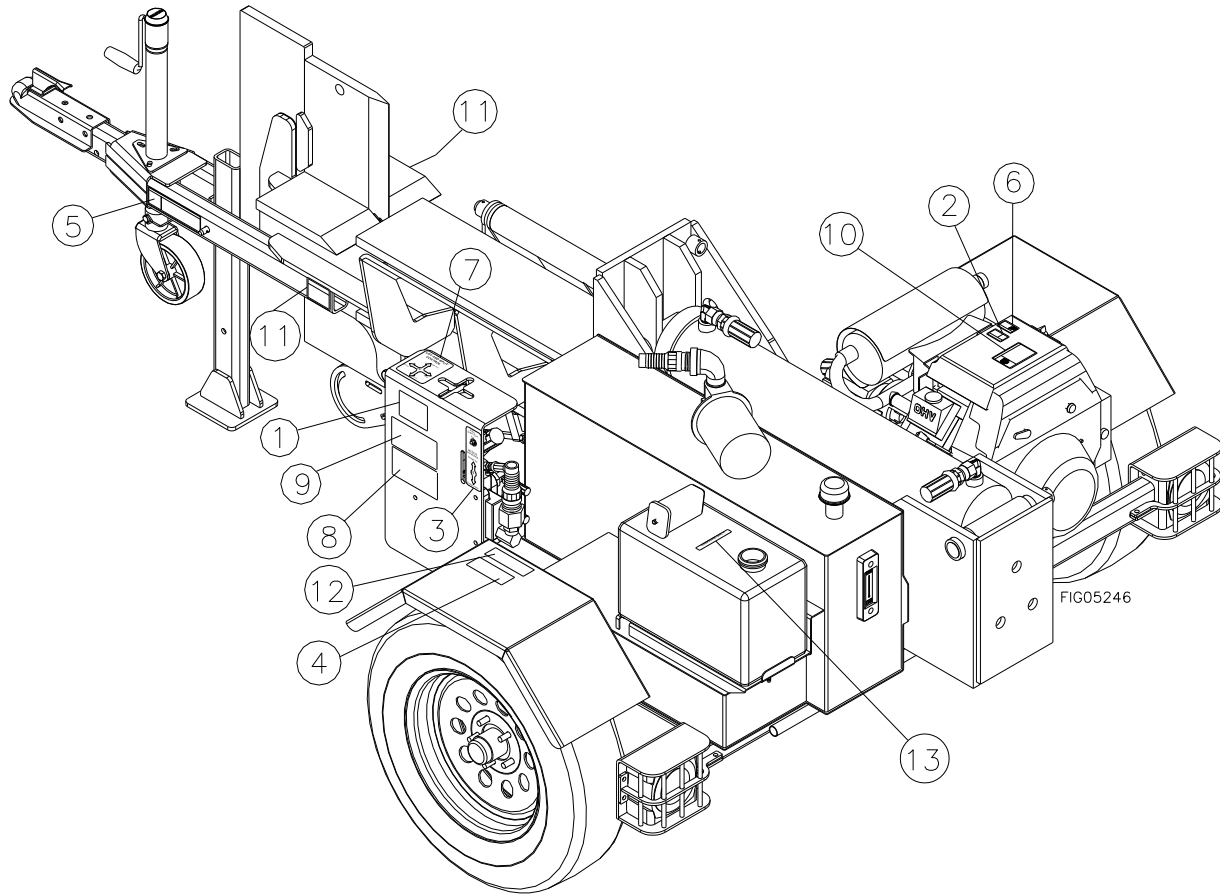

Reference #	Part Number	Description
1	777335	Warning Decal
3		Kill switch/ Wedge Control Decal
7		Lift and Split Control Decal
11		Pinch Point Warning Decal
13		Gasoline Only Decal
2	777890	Fire Hazard Warning Decal
4	777891	Hydraulic Fluid Warning Decal
5	777892	Moving/Towing Decal
6	305546	Hot Muffler Decal
8	777888	Stuck Log Warning Decal
9	777887	Splitter Operating Instruction Decal
10	788937	Decal, Poisonous Gas
12	777898	Log Lift Crush Hazard Decal

**Always make sure safety labels are in place and in good condition.** If a safety label is missing or not legible, order new labels or unsafe operation could result. **To order replacement safety labels,** call NorthStar Product Support at **1-800-270-0810**. See table for title and part number.

# Safety Label Locations

1

**▲ WARNING**

Moving parts can crush and cut. Pieces can fly out while splitting. Follow safety rules for operating the log splitter or serious injury could result.

- READ the Owner's Manual completely before operating.
- Only one person should operate the log splitter. If an assistant is helping to load logs, the operator should not actuate controls until the assistant is at least 10 ft away.
- Stay in the designated OPERATOR POSITION while actuating the controls.
- Split wood in direction of the grain only.
- Hold bark side of logs when loading.
- Keep hands away from wedge, endplate/ram, and partly split logs.
- Never leave log splitter unattended during operation.
- Stay off slopes and slippery surfaces.

See additional safety rules in the Owner's Manual.

©2005 Northern Tool + Equipment Co. 1-800-270-0810 PN 777335

2

**▲ WARNING**

**FIRE HAZARD**



- Hot exhaust can ignite dry brush, trees, or grass.
- Equip engine with a spark arrestor if you will be using near ignitable forest, brush or grassy covered land.
- Keep a fire extinguisher on hand that is rated for ordinary combustibles & flammable liquids.

©2005 Northern Tool + Equipment Co. 1-800-270-0810 PN 777860

3

**KILL SWITCH**

RUN



OFF

**WEDGE CONTROL**

Wedge Up



Wedge Down

PN 777335

5

**MOVING/TOWING INSTRUCTIONS**

<p><b>Moving Log Splitter by Hand:</b></p> <ul style="list-style-type: none"> <li>• Lock beam in horizontal position (tip-up models only).</li> <li>• Lock towbar leg in DOWN position.</li> <li>• Lock support leg in UP position (if equipped).</li> <li>• DO NOT attempt to move log splitter up or down slope by hand.</li> </ul>	<p><b>Towing Log Splitter:</b></p> <ul style="list-style-type: none"> <li>• Latch coupler securely to class 2 or higher hitch with 2" ball.</li> <li>• Lock towbar leg and support leg (if equipped) in the UP position.</li> <li>• Attach safety chains to tow vehicle.</li> <li>• Close fuel shut-off valve on engine (if equipped).</li> <li>• DO NOT tow faster than 45 MPH. Higher speeds can cause loss of control.</li> <li>• Check local, state and federal requirements before towing on public roads.</li> </ul>
---------------------------------------------------------------------------------------------------------------------------------------------------------------------------------------------------------------------------------------------------------------------------------------------------------------------------------------	----------------------------------------------------------------------------------------------------------------------------------------------------------------------------------------------------------------------------------------------------------------------------------------------------------------------------------------------------------------------------------------------------------------------------------------------------------------------------------------------------------------------------

© Northern Tool + Equipment Co. 1-800-270-0810 PN 777892

7

**LIFT AND SPLIT CONTROL**

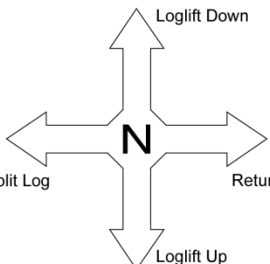

PN 777335

6

**▲ WARNING**

**BURN HAZARD**

Do not touch hot muffler.



©2005 NT+E 1-800-270-0810 PN 305546

8

**▲ WARNING**

**IF LOG BECOMES STUCK ON WEDGE**

A log can become stuck to the wedge if the wedge becomes embedded in the log and the log doesn't split and separate. This can happen if the log is too stringy or tough to split completely. A stuck log will move back with the wedge on the initial attempt to retract the wedge. If this happens, STOP retracting the wedge immediately and follow the directions below. NEVER attempt to remove a stuck log by:

- Using the hydraulic force of the splitter
- Modifying the splitter
- Adding attachments to the splitter.

Personal injury could result from log or metal pieces flying out at high speed toward the operator or bystanders, or the splitter could become damaged.

**ALWAYS remove the log MANUALLY using the following procedure:**

1. If there is already 1" or more of clearance between the log and endplate, go to step 2. Otherwise, retract wedge just enough to remove pressure between the log and endplate - about 1" clearance.
2. Turn engine/motor OFF.
3. Remove stuck log from the wedge manually with a pry bar or sledgehammer.

Important: Be extremely careful as log pieces may fly off as they separate from the wedge. Wear safety goggles and make sure bystanders are clear.

4. Do not attempt to respit a stuck log once it has been removed from the wedge.

PN 777866

9

**OPERATING INSTRUCTIONS**

**GENERAL**

- Stay in the OPERATOR POSITION while actuating controls.
- Never actuate controls until the helper is 10ft away from log splitter, including any helpers assisting to load logs.
- Wear eye protection, hearing protection, snug fitting gloves, and safety shoes or heavy boots. No loose or dangling apparel.

**SETTING UP**

- Place log splitter on dry, level ground.
- Secure splitter for unintended movement.
- Place splitter in horizontal or vertical position.
- Start engine/motor.

**SPLITTING LOG**

- Position log on beam, against endplate.
- Move split control to extend wedge and split log.
- Release split control to stop wedge.
- Move split control to return wedge.
- Remove split wood from work area.



Operator Position - horizontal



Operator Position - vertical

PN 777865

10

**▲ WARNING**

**Poisonous Gas**

This product gives off carbon monoxide, a poisonous gas that can kill you. You CANNOT smell it, see it, or taste it.

- ONLY use outside & far away from windows, doors, & vents.
- NEVER use inside homes, garages, or sheds, EVEN if you run a fan or open doors or windows. See owner's manual for more details.



11

**▲ WARNING**

**PINCH POINT**

Keep hands and feet clear of wedge mechanism.

©2004 Northern Tool + Equipment Co. 1-800-270-0810 PN 777335

12

**▲ WARNING**

**LOG LIFT CRUSH HAZARD**

- Activate log lift control only from designated operator position.
- Keep all other persons at least 10ft. away before activating log lift.
- Keep hands clear while log is rolling into splitting position.
- Activate lift control with hands only.

**LOG LIFT ACCIDENTAL ACTIVATION HAZARD**

- NEVER reach across splitter to pull log off log lift into splitting position. Controls could be accidentally activated. Walk around to log lift side instead.



©2005 Northern Tool + Equipment Co. 1-800-270-0810 PN 777868

13

**GASOLINE ONLY**

Fig. 5247

# Machine Component Identification

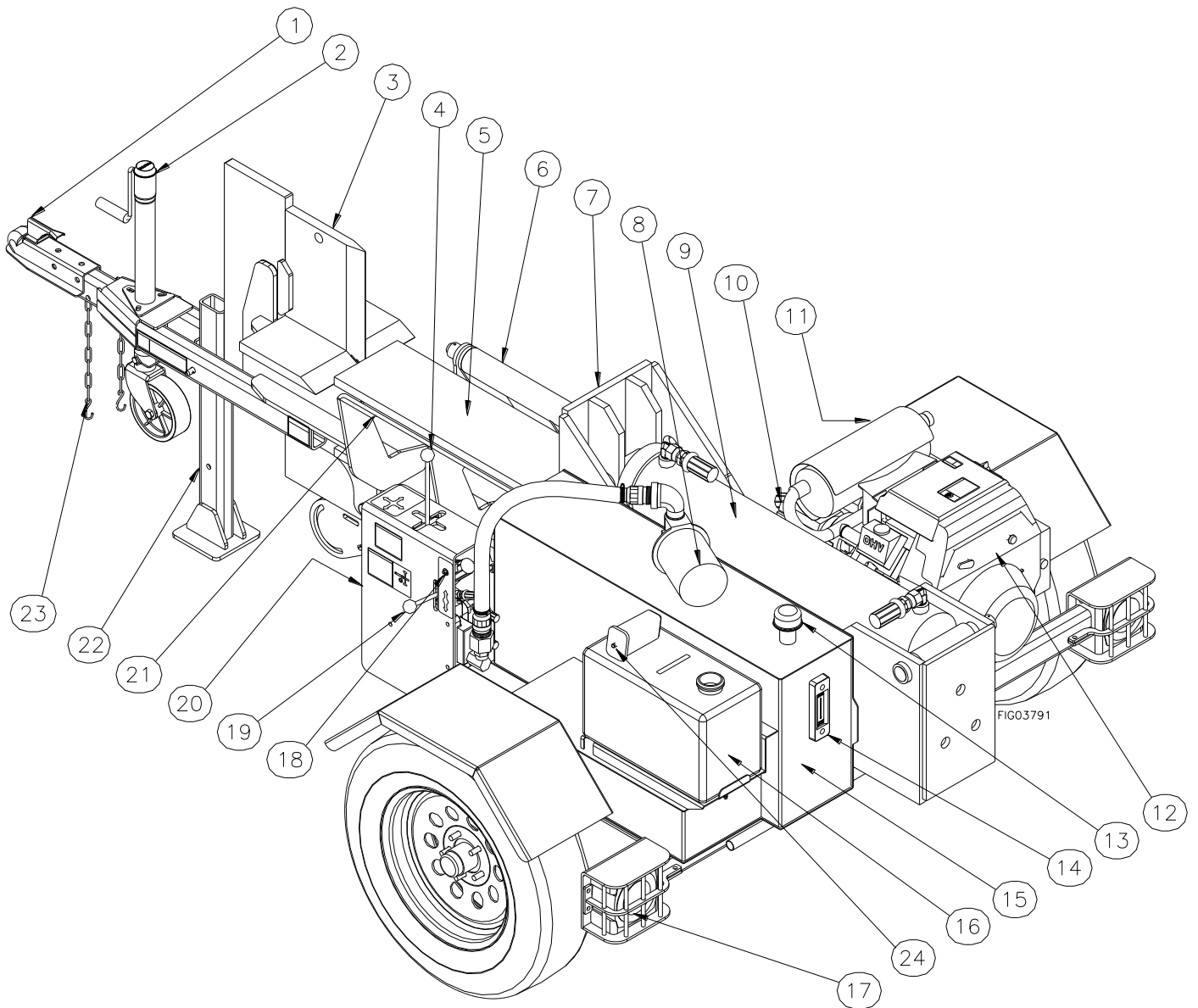

Ref	Description
1	2" Ball Coupler
2	Jack
3	4-Way Wedge
4	Lift and Split Control
5	Beam
6	Log Lifter
7	Ram
8	Return Filter
9	Cylinder
10	Pump
11	Battery Box (next to engine)
12	Engine

Ref	Description
13	Hydraulic Tank Fill Cap
14	Hydraulic Temp Gauge/Oil Level Indicator
15	Hydraulic Tank
16	Engine Fuel Tank
17	Light Kit
18	Engine Kill Switch
19	Wedge Control
20	Control Valve
21	Log Cradle
22	Tow Bar Leg
23	Safety Chains
24	Carbon Canister

# Initial Unpacking and Set-Up

** IMPORTANT!**

**Engine is shipped without oil. DO NOT start the engine before adding oil.**

<b>Step One: Add oil to engine</b>	<p><b>Add oil to the engine.</b> Using a funnel, add SAE 10W-30 oil up to the FULL mark on the dipstick. (See engine owner's manual for oil capacity and location of fill cap.)</p>
<b>Step Two: Inspect log splitter components</b>	<p><b>Closely inspect all log splitter components.</b> (See Machine Components section of this manual on p. 6 for diagram of components.)</p> <ul style="list-style-type: none"> <li>• If you have missing or damaged components, please contact Product Support at 1-800-270-0810.</li> </ul>
<b>Step Three: Verify hydraulic oil level</b>	<p><b>Verify hydraulic oil level.</b> Use following procedures: <u>Note:</u> Hydraulic reservoir is shipped <u>with</u> oil.</p> <ol style="list-style-type: none"> <li>1. Check hydraulic oil level:             <ol style="list-style-type: none"> <li>a) Make sure engine is off and the cylinder is fully retracted.</li> <li>b) Relieve all hydraulic system pressure by moving Split Control Lever back and forth several times.</li> <li>c) Verify hydraulic fluid level is filled to “High” mark on hydraulic tank gauge.</li> </ol> <p style="margin-left: 40px;"><b>WARNING:</b> NEVER remove the hydraulic oil fill cap when the engine is running or hot. Hot oil can escape causing severe burns. Allow log splitter to cool completely before removing hydraulic oil fill cap.</p> </li> <li>2. If hydraulic oil level is low: Add 10 wt. AW32, ASLE H-150, or ISO 32 oil to the “High” mark on tank gauge. <u>Note:</u> The log splitter comes filled with LIGHT 150-ISO 32 hydraulic oil. If the log splitter will be run for long periods of time in outdoor temperatures above 70° F, we recommend changing the hydraulic oil to DEXTRON III.</li> </ol>
<b>Step Four: Prime the Pump</b>	<ol style="list-style-type: none"> <li>1. Remove the spark plug wire from the spark plug</li> <li>2. Pull on the starter grip recoil at least 20 times so that hydraulic fluid has cycled through the pump</li> <li>3. Return the spark plug wire to the spark plug</li> <li>4. Verify the Hydraulic oil Level, if low add fluid as necessary</li> </ol>
<b>Step Five: Lubricate slide rail beam</b>	<p><b>Lubricate the surface of the slide rail beam with engine oil.</b> This will help prevent wear between the slide plates and beam.</p>

## Connecting Battery to Engine

Your log splitter's engine is equipped with an electric starter, which requires the installation of a 12-volt (or 12V) lawn tractor size battery (Group U1-7). The battery should have a minimum rating of 18 Amp-hour (or 18Ah). The battery is to be supplied by the customer and should be installed in the protective battery box located near the engine. Follow the instructions below for connecting and disconnecting the battery.

### WARNING

Batteries are hazardous because they contain caustic acid, can emit explosive gases, and can cause electric shock.

*Caution must be exercised when making connections to a battery to avoid shock and contact with the acid, and to prevent any sparking that could lead to an explosion.*

ALWAYS follow the general safety rules, plus the instructions listed below in exact sequence, when connecting/disconnecting the battery.

### General battery safety rules

- ALWAYS use eye protection
- NEVER smoke or work near sparks or other sources of ignition.
- NEVER touch both battery terminals at the same time with your hand or any non-insulated tools.
- If battery acid contacts skin or clothing, flush immediately with water and neutralize with baking soda.

### Instructions for connecting the battery:

 **WARNING:** Always connect the cables in the following sequence to avoid possible shock.

1. Find the battery cables located inside the battery box.
2. Connect the **red** cable to the **positive** (+) terminal of the battery.
3. Then connect the **black** cable to the **negative** (-) terminal of the battery.

### Instructions for disconnecting the battery:

 **WARNING:** Always disconnect the cables in the following sequence to avoid possible shock.

1. First, disconnect the **black** cable from the **negative** (-) terminal of the battery.
2. Next, disconnect the **red** cable from the **positive** (+) terminal of the battery.

# Moving and Towing to the Job Site

## WARNING

The log splitter is heavy. It can crush and cause serious injury if it rolls out of control or tips over. Follow the instructions below for safely moving and towing the log splitter.

### Moving the log splitter

**1. Lock log lift in UP position**

**Raise the log lift to the full upright (vertical) position.**

Never move log splitter when the log lift is down because the log splitter will be unbalanced and difficult to move, and the lifter is more likely to be damaged.

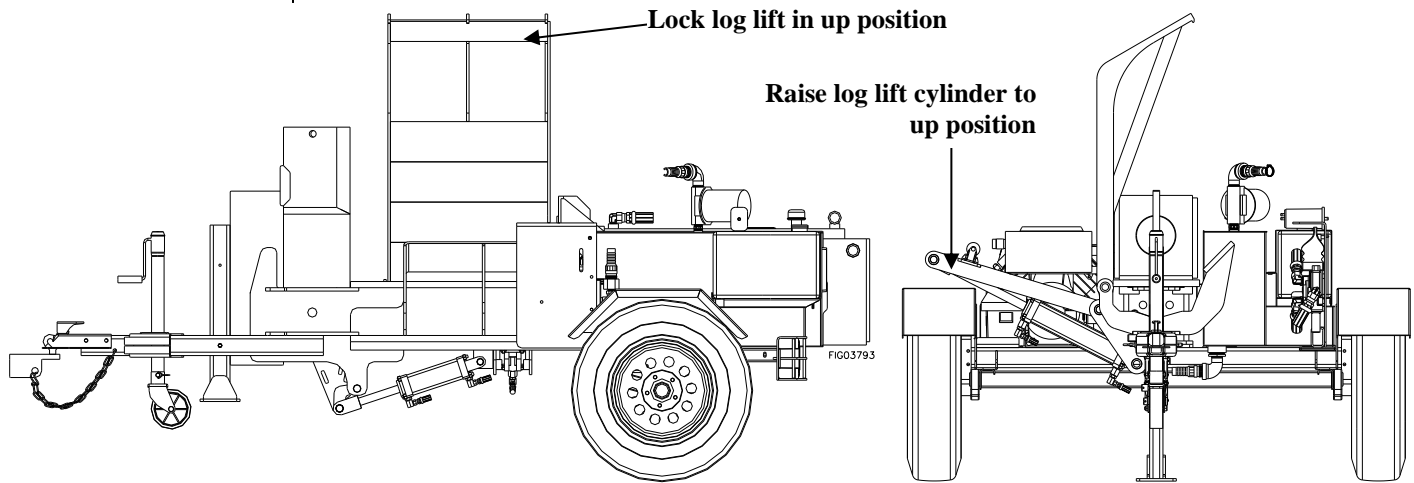

**2. Engine off**

**IMPORTANT: Make sure log splitter engine is off.**

Never move the log splitter with its engine running.

**3. Fuel valve off**

**Turn fuel valve off** to prevent carburetor flooding and reduce the chance of fuel leakage.

**4. Lock leg/crank down**

**Crank the jack all the way down so that it is bearing the tongue weight of the trailer and the jack's wheel can be used to roll the splitter.** (After the weight of the splitter is shifted from the leg to the jack, the leg can either be locked in the up position or left down.)

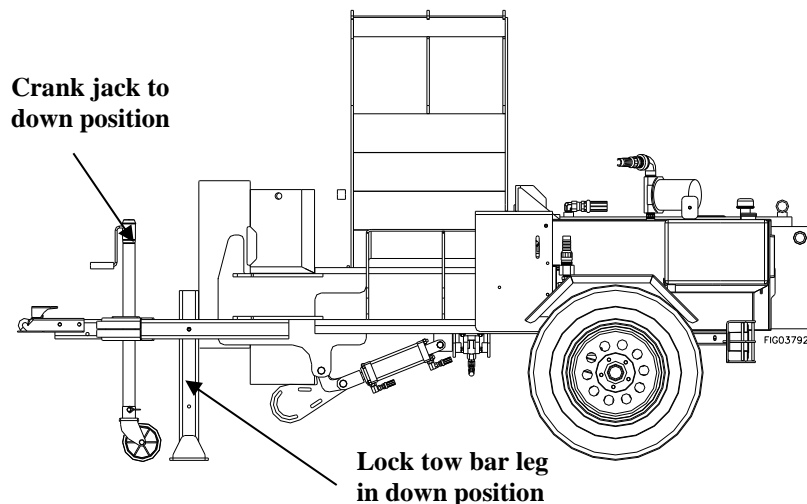

# Moving and Towing to the Job Site

5. Move log splitter to work site or tow hitch

Roll the splitter by hand either directly to chosen work site or to vehicle hitch for towing.

(See instructions on p. 19 on selecting a work site.)

Important Safety Instructions:

- **Hills.** Do not move the log splitter up or down hills by hand - use a towing vehicle.
- **No riding.** Never allow anyone to sit or ride on the log splitter.
- **No cargo.** Never transport cargo or wood on the log splitter.

Towing:

1. Read instructions

Review towing safety instructions in your vehicle manual.

2. Check tires

Make sure tires are fully inflated and in good repair.

See tire sidewall for recommended tire pressure.

**⚠ WARNING:**

- Do not over-inflate tires. Serious injury can occur if tire explodes
- When seating a bead after repair, do not exceed 30 PSI. Pressures higher than 30 PSI can cause the tire and wheel to rupture and explode.

3. Raise 4-way wedge and lock.

Fully raise up the 4-way wedge and secure it in position with travel pin.

1. Turn on the splitter and use the wedge control to raise the wedge to its highest position.
2. Locate the travel pin behind the crank jack and use the pin to secure the wedge's position.

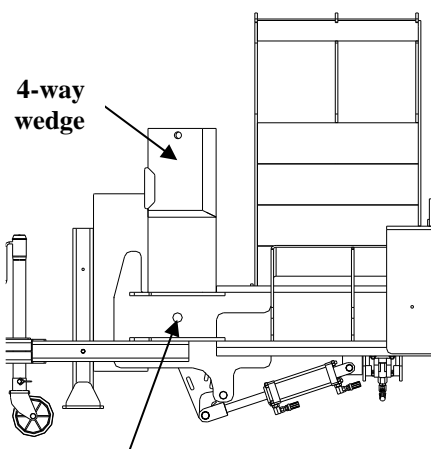

Insert travel pin for 4-way wedge here

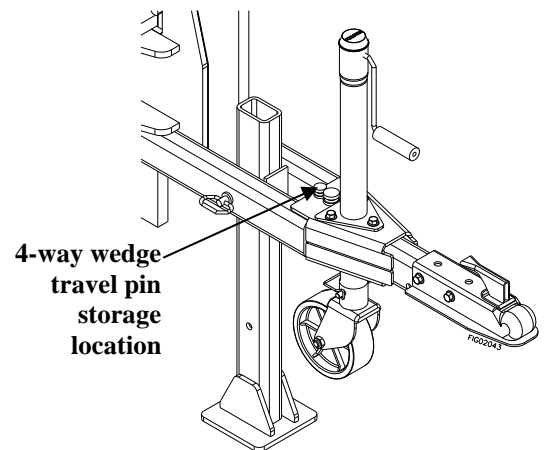

# Moving and Towing to the Job Site

## 4. Lock log lift in UP position

Secure log lift into the UP (vertical) position using the travel pin.  
Locate the travel pin stored behind the crank jack and use it to secure the log lift in the vertical position.

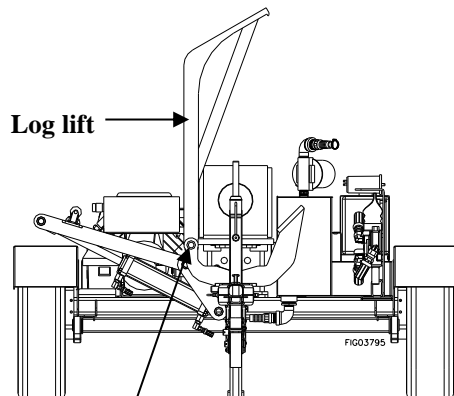

Insert travel pin for log lift here

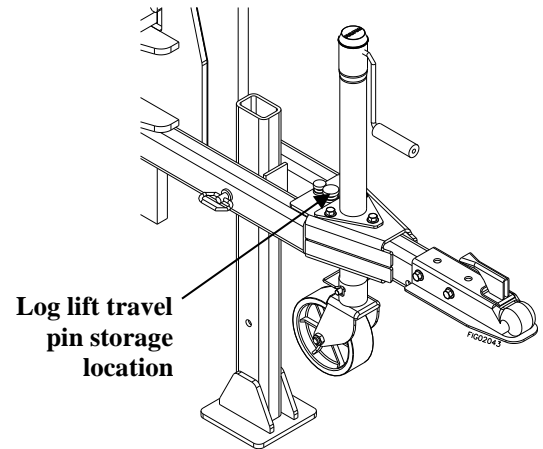

## 5. Turn engine off

**Turn engine off.**  
Never move the log splitter with its engine running.

## 6. Turn fuel valve off

**Turn fuel valve off.**  
This will prevent carburetor flooding and reduce the chance of fuel leakage.

## 7. Attach to hitch ( 2" ball)

**Attach log splitter to vehicle hitch**

1. Attach log splitter's coupler to a class 2 or higher hitch with 2" ball (only).
2. Adjust coupler to ball by raising locking lever and turning lock nut with fingers.
3. Proper adjustment is obtained when coupler is as tight as possible on ball and locking lever can still be opened and closed.
4. Lock lever closed to secure the attachment. An optional locking pin or padlock may be inserted in the locking lever hole for extra security.

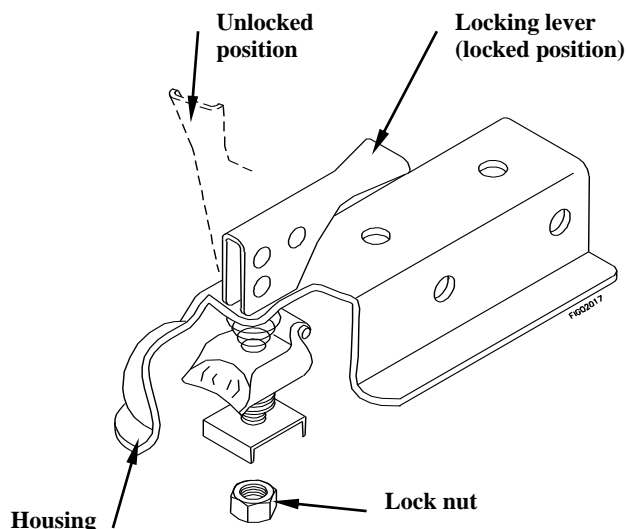

## 8. Attach Safety Chains

**Attach safety chains.**

1. Two safety chains must be used while towing.
2. Cross safety chains under the coupler allowing only enough slack for vehicle turns.

## Moving and Towing to the Job Site

**9. Put jack and tow bar leg UP.**

To provide adequate ground clearance while towing, secure both the jack and tow bar leg in the "UP" position.

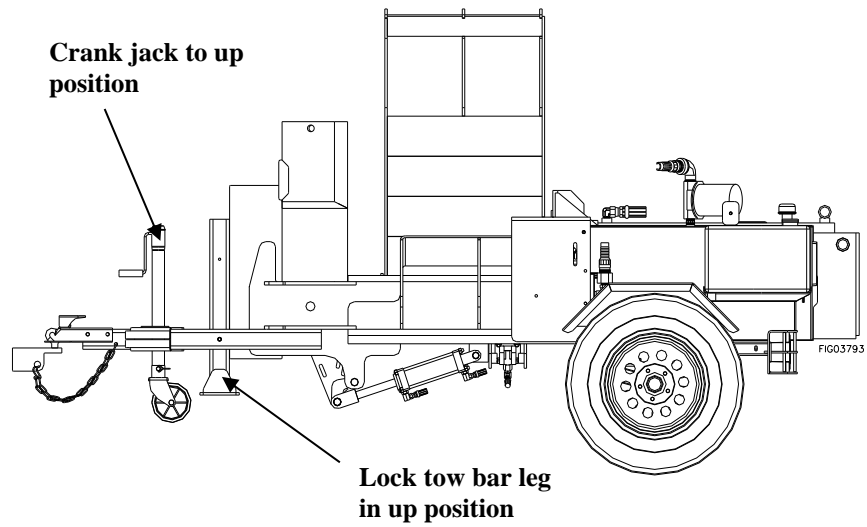

**10. Tow to desired location**

**Tow log splitter carefully to desired work site.**

(See instructions on pg.17 on selecting an appropriate work site.)

**Important safety instructions:**

- **Added length.** Be aware of the added length of the splitter.
- **Speed limit.** Never tow this log splitter over 45 mph. Faster speeds may result in loss of control.
- **Rough terrain.** Drive slowly and take extra caution when traveling over rough terrain.
- **On public roads.** If towing on a public road, make sure to comply with all local, state, and federal towing requirements. It is the sole responsibility of the purchaser to obtain licensing, trailer lights, safety chains or signage, as needed to comply.
- **Unattended.** Turn off the towing vehicle before leaving the splitter unattended.
- **Under the influence.** Never tow or operate this splitter while under the influence of alcohol, drugs, or medication.

**11. Lower jack down and unhitch**

**Lower the jack down and then unhitch from vehicle.**

NEVER operate log splitter while it is attached to the vehicle.

1. Lower the jack and use it to lift the coupler slightly to assist in unhitching.
2. Unhitch from vehicle.

# Before Each Use – Step One: Inspection / Maintenance

## **Step One: Inspect and maintain log splitter before each use.**

If the log splitter has been used previously, it must be inspected and maintained BEFORE EACH SUBSEQUENT USE.

### **⚠ WARNING**

ALWAYS shut off the engine, disconnect the spark plug, and relieve system pressure before inspecting, cleaning, adjusting, or repairing the splitter. Relieve system pressure by moving Split Control Lever back and forth several times.

## **IMPORTANT:**

If a part needs replacement, only use parts that meet the manufacturer's specifications. Replacement parts that do not meet specifications may result in a safety hazard or poor operation of the log splitter.

<b>1. Engine off / relieve pressure</b>	<p><b>Perform all inspections/repairs with the engine off and hydraulic system pressure relieved.</b></p> <ol style="list-style-type: none"> <li>1. Make sure engine is off and cool.</li> <li>2. Disconnect the spark plug.</li> <li>3. Relieve all hydraulic system pressure by moving the Split Control Lever back and forth several times.</li> </ol>
<b>2. Remove debris</b>	<p><b>Remove debris from engine, muffler, and moving parts.</b></p> <ol style="list-style-type: none"> <li>1. <u>Engine debris.</u> Debris on a hot engine can be a fire hazard. Clean debris and chaff from engine cylinder head, cylinder head fins, blower housing rotating screen, and muffler areas. Avoid contact with hot muffler.</li> <li>2. <u>Other debris.</u> Debris on moving parts can cause excess wear. Clear debris from the slide beam, ram, and wedge.</li> </ol>
<b>3. Fuel tank / lines</b>	<p><b>Check fuel tank and fuel lines for leaks.</b> Any fuel leak is a fire hazard. Fix any fuel leaks before starting engine.</p>
<b>4. Mechanical parts</b>	<p><b>Check to be sure all nuts and bolts are tight</b> to make sure the log splitter is in safe working condition.</p>
<b>5. Hydraulic system</b>	<p><b>Check the hydraulic system carefully:</b></p> <ol style="list-style-type: none"> <li>1. Visually inspect all hoses, tubing, clamps/fittings, pump, and cylinder for cracks, fraying, kinks, or other damage.</li> <li>2. Check all components for oily residue, which may indicate a leak.</li> </ol> <p>Do NOT operate the log splitter if there is any indication of damage or oily residue. Small leaks in hydraulic lines can cause severe injuries and can also be an indication of catastrophic failure in the near future. The life of hydraulic hoses may be from a few months to a few years, depending on use and storage patterns.</p> <p><b>⚠ WARNING:</b> High fluid pressures and temperatures are developed in hydraulic log splitters. Hydraulic fluid escaping through a pin hole sized opening can burn or puncture skin, resulting in wounds that could cause blood poisoning, infection, disability, gangrene, amputation, or death. Therefore, the following instructions should be heeded at all times when inspecting or servicing the hydraulic components of the log splitter:</p>

## Before Each Use – Step One: Inspection / Maintenance

	<ul style="list-style-type: none"> <li>• Stop the engine, disconnect the spark plug, and move all control valve handles back and forth to relieve pressure before changing or adjusting hydraulic system components such as hoses, tubing, fittings or other components.</li> <li>• Never check for leaks with your hand. Leaks can be located by holding a piece of cardboard or wood (at least two feet long) with your hand at one end, then passing the other end over the suspected area. Wear eye protection when doing this inspection. Look for discoloration of the cardboard or wood.</li> <li>• Never adjust the pressure setting of the bump or valve.</li> <li>• If injured by escaping fluid, no matter how small the wound is, see a doctor at once. A typical injection injury may be a small puncture wound that does not look serious. However, severe infection or reaction can result if proper medical treatment is not administered immediately by a doctor who is familiar with injection injuries.</li> </ul>
<b>7. Hydraulic oil level</b>	<p><b>Make sure hydraulic oil level is filled to “High” mark on the Hydraulic Temp Gauge/Oil Level Indicator with cylinder retracted.</b> Fill as needed.</p> <p><u>NOTE:</u> The log splitter comes filled with LIGHT 150-ISO 32 hydraulic oil. If the log splitter will be run for long periods of time in outdoor temperatures above 70°F, we recommend changing the hydraulic oil to DEXTRON</p> <p><b>▲WARNING: NEVER remove the hydraulic oil fill cap when the engine is running or hot. Hot oil can escape causing severe burns. Allow log splitter to cool completely before removing hydraulic oil fill cap.</b></p>
<b>8. Engine</b>	<p><b>Inspect and perform engine maintenance as directed in the engine manual.</b></p>
<b>9. Spark arrestor muffler</b>	<p><b>If the engine is equipped with a spark arrestor muffler, clean and inspect it regularly (follow spark arrestor manufacturer's service instructions).</b> Replace if damaged</p>
<b>10. Tires</b>	<p><b>Make sure tires are fully inflated and in good repair if you will be towing the splitter.</b></p> <p>See tire sidewall for recommended tire pressure.</p> <p><b>▲WARNING:</b></p> <ul style="list-style-type: none"> <li>• Do not over-inflate tires. Serious injury can occur if tire explodes.</li> <li>• When seating a bead after repair, do not exceed 30 PSI. Pressures higher than 30 PSI can cause the tire and wheel to rupture and explode.</li> </ul>
<b>11. Shields / guards</b>	<p><b>Replace all guards and shields after servicing the log splitter.</b></p>

## Before Each Use – Step Two: Fueling

### Step Two: Fueling

#### ! WARNING

Gasoline is highly flammable and explosive. You can be burned or seriously injured when handling fuel. Use extreme care when handling gasoline.

<b>1. Engine off / cool</b>	<p><b>The engine must be off and allowed to cool at least two minutes before adding fuel.</b></p> <p><b>! WARNING:</b> A running engine is hot enough to ignite fuel. Never add fuel or remove gas cap if engine is running or still hot.</p>
<b>2. Outdoor location</b>	<p><b>Fill fuel outdoors – never indoors.</b></p> <p><b>! WARNING:</b> Gasoline vapors can ignite if they collect inside an enclosure. Explosion can occur.</p>
<b>3. Remove gas cap</b>	<p><b>Remove engine gasoline cap.</b></p>
<b>4. Add gasoline</b>	<p><b>Add gasoline through fill opening from an UL-listed container.</b></p> <p><b>Important Safety Instructions:</b></p> <ul style="list-style-type: none"> <li><b>Use approved container.</b> NEVER pump fuel directly into engine at gas station. Static charge can build and ignite fuel. Use a UL listed fuel container to transfer gas to the engine.</li> <li><b>Don't overfill.</b> DO NOT overfill the gas tank. Allow at least 1/2" of empty space below the fill neck to allow for fuel expansion.</li> <li><b>Heat / flames / sparks.</b> Stay away from sources of heat, flame, or sparks while adding fuel.</li> </ul> <div style="text-align: center; margin: 10px 0;">  </div>
<b>5. Spills / splashes</b>	<p><b>Clean up fuel spills / splashes immediately.</b></p> <ol style="list-style-type: none"> <li>1. Move log splitter away from spilled fuel on the ground.</li> <li>2. Wipe fuel off engine and wait 5 minutes for excess fuel to evaporate before starting engine.</li> <li>3. Gas-soaked rags are flammable and should be disposed of properly.</li> <li>4. If gasoline is spilled on your skin or clothes, change clothes and wash skin immediately.</li> </ol>
<b>6. Replace gas cap</b>	<p><b>Replace gas cap securely before starting engine.</b></p>
<b>7. Gasoline storage</b>	<p><b>Store extra gasoline in a cool, dry place in an UL listed, tightly sealed container.</b></p>

# Before Each Use – Step Three: Work Site Selection and Setup

## Step Three: Work site selection and log splitter setup.

### ! WARNING

It is important to select an appropriate work site and properly set up the log splitter in order to minimize the risk of slips and falls, equipment rolling or tipping over, carbon monoxide poisoning, and accidental fires.

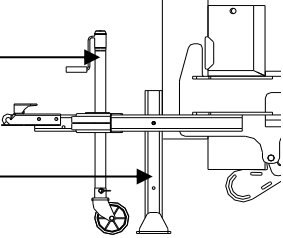
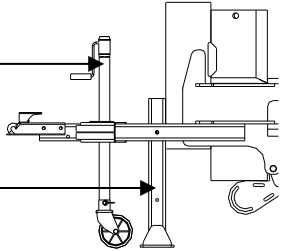
<b>1. Select location</b>	<p><b>Select an appropriate location for operating the log splitter.</b></p> <p><u>Requirements:</u></p> <ol style="list-style-type: none"> <li>1. Dry, level surface with good footing. Stay clear of areas with mud, ice, tall grass, weeds, or brush.</li> <li>2. Outdoors, away from air intakes.</li> </ol> <p><b>!WARNING:</b> The running engine gives off carbon monoxide, a poisonous gas that can kill you. You CANNOT smell it, see it, or taste it.</p> <ul style="list-style-type: none"> <li>• ONLY run log splitter <u>OUTDOORS</u> and at least 20 feet from the home, away from windows, vents and air intakes, to allow proper ventilation. NEVER run log splitter inside homes, garages, sheds, or other buildings or semi-enclosed spaces. These spaces can trap poisonous gases, EVEN if you run a fan or open windows.</li> <li>• If you start to feel sick, dizzy, or weak while using the log splitter, shut off the engine and get to fresh air RIGHT AWAY. See a doctor. You may have carbon monoxide poisoning.</li> </ul>
<b>2. Fire precautions</b>	<p><b>Take the following precautions against fire:</b></p> <ol style="list-style-type: none"> <li>1. <b>IMPORTANT:</b> If your splitter will be used near any unimproved forest, brush, or grassy covered land, then engine must be equipped with a <u>spark arrestor</u>. (See the "Specifications" section of this manual to determine if your splitter already has a spark arrestor. Contact NorthStar Product Support at 1-800-270-0810 for information about obtaining a spark arrestor for your log splitter if it is unequipped.)</li> <li>2. Make sure you comply with applicable local, state and federal codes.</li> <li>3. Keep a fire extinguisher available (classified for both ordinary combustibles and flammable liquids) as a precautionary measure when operating the log splitter in dry areas.</li> </ol>
<b>3. Position 7' from any combustibles or flammable liquids</b>	<p><b>Position splitter at least 7 feet from combustible objects during operation.</b></p> <p>Hot exhaust fumes from tractor engine could cause fire. Also, hydraulic oil leaking or spraying on hot engine can ignite.</p>
<b>4. Lock leg DOWN</b>	<p><b>Lock leg in the "DOWN" position using tow bar leg locking pin. Then raise jack so that log splitter weight is supported on leg.</b></p> <p>In this position, splitter is level for splitting and less likely to roll during operation.</p> <div style="display: flex; justify-content: space-around; align-items: flex-start;"> <div style="text-align: center;"> <p>Crank jack to the down position</p>  <p>Lock tow bar in the down position</p> </div> <div style="text-align: center;"> <p>Crank jack to the down</p>  <p>Lock tow bar in the down position</p> </div> </div>
<b>5. Block wheels</b>	<p><b>Block the wheels to prevent unintended movement of the log splitter.</b></p>

# Splitting Operation

## WARNING

Before starting the log splitter, review the following instructions and safety information for safe operation.

Failure to follow these rules may result in serious injury to the operator or bystanders from moving parts that crush, cut, or entangle; from flying objects, burns, fire, falling or tripping; or from carbon monoxide poisoning.

### General safety information:

- **Read manual.** Do not allow anyone to operate the log splitter who has not read the Owner's Manual or has not been instructed on the safe use of the splitter. The log splitter owner should instruct all operators in safe log splitter operation.
- **Age restrictions.** Never allow anyone under 16 years old to operate the log splitter. Children 16 years and older must be trained and supervised by a trained adult.
- **Intended use.** Log splitters should only be used for splitting wood logs, lengthwise with the grain. Do not use for other purposes as unforeseen hazards may result.
- **Modifications.** Never modify or alter the log splitter in any way. Modifications can create serious safety hazards and will void the warranty:
- **Attachments.** Never add attachments to the splitter, except for authorized accessories supplied by the manufacturer with instructions for safe installation and use.
- **Engine speed.** The maximum engine speed is preset at a safe limit. Never attempt to modify the engine speed setting to run at a higher speed.
- **Fuel/exhaust system.** NEVER modify or add to the exhaust system, fuel tanks, or fuel lines. Fire can result.
- **Remote control.** NEVER attach a rope, cable, or other remote device to the splitting control.
- **Splitting wedge.** NEVER attempt to change the height or speed of the ram.
- **Pressure setting.** NEVER increase the pressure setting of the pump or control valve.
- **Safety equipment/controls.** Always operate the log splitter with all safety equipment in place and in good working order, and all controls properly adjusted for safe operation.
- **Know how to stop the log splitter.** Be thoroughly familiar with all controls and with the proper use of the equipment. Know how to stop the log splitter and relieve system pressures quickly if needed.
- **Operating speed.** Always operate the log splitter at the manufacturer's recommended speed. The maximum speed of the engine, pump and ram are preset within safe limits.
- **Daylight only.** Only use the log splitter in daylight so you can see what you are doing.
- **Smoking/sparks.** Never smoke while operating the log splitter, and never operate near sources of sparks or flames.
- **Under the influence.** Never operate, or let anyone else operate, the log splitter while under the influence of alcohol, drugs, or medication.
- **Unattended.** Never leave the machine unattended while the engine is running.
- **Refueling.** Never refuel the engine until it has cooled at least two minutes.
- **Adjusting/repairing.** Always make sure the engine is off before cleaning, repairing or adjusting the splitter, except as recommended by the manufacturer. In addition, disconnect the spark plug and move all control handles back and forth to relieve system pressure *before changing or adjusting hydraulic system components* such as hoses, tubing, fittings or other components.
- **Replace labels.** Always make sure safety labels are in place and in good condition. If a safety label is missing or not legible, order new labels because unsafe operation can result. Call 1-800-270-0810 to order new safety labels

# Splitting Operation

<p><b>1. Put on protective clothing/gear</b></p>	<p><b>Wear the following protective clothing and safety gear.</b></p> <ol style="list-style-type: none"> <li>1) <b>Eye protection.</b> Always wear safety glasses or goggles when operating the machine. Pieces of log may fly out and serious eye injury can occur.</li> <li>2) <b>Boots.</b> Falling logs can crush feet. Always wear safety shoes or heavy boots when operating or helping to load logs.</li> <li>3) <b>Gloves.</b> Wear snug fitting gloves without draw strings or loose cuffs.</li> <li>4) <b>Hearing protection.</b> The use of ear plugs or other hearing protection device is recommended.</li> <li>5) <b>No Loose/dangling.</b> Loose or dangling apparel can become entangled in moving parts. Never wear jewelry or loose-fitting clothing.</li> </ol>
<p><b>2. Lock and block</b></p>	<p><b>Secure log splitter from unintended movement. Check that:</b></p> <ol style="list-style-type: none"> <li>1) The <u>tow bar leg</u> is locked in the DOWN position AND the <u>jack</u> is RAISED so that the log splitter's weight is supported on the leg. (In this position, the splitter is level for splitting and less likely to roll during operation.)</li> <li>2) The wheels are blocked.</li> </ol>
<p><b>3. Start engine</b></p>	<p><b>Turn the kill switch to the "run" position before starting engine.</b> For location refer to the Machine Component Identification section of your manual.</p> <p><b>Start the engine.</b> See the engine owner's manual for engine starting instructions.</p> <p>Note:</p> <ol style="list-style-type: none"> <li>a) Make sure the hydraulic oil is above 10°F before starting the engine. Cold hydraulic oil can damage the hydraulic pump.</li> <li>b) If outdoor air temperature is below 32°F, allow log splitter to warm up by extending and returning the wedge several times before splitting wood.</li> </ol> <p><b>⚠WARNING:</b></p> <ul style="list-style-type: none"> <li>• <b>Burns.</b> To avoid burns, stay clear of hot muffler if you are starting a warm engine.</li> <li>• <b>Carbon monoxide.</b> The running engine gives off carbon monoxide, a poisonous gas that can kill you. You CANNOT smell it, see it, or taste it. If you start to feel sick, dizzy, or weak while using the log splitter, shut off the engine and get to fresh air RIGHT AWAY. See a doctor. You may have carbon monoxide poisoning.</li> <li>• <b>Other exhaust dangers.</b> Engine exhaust, some of its constituents, and certain vehicle components contain or emit chemicals known to the State of California to cause cancer, birth defects, or other reproductive harm. Avoid inhalation of exhaust.</li> </ul>
<p><b>4. Use power log lift to load log (optional)</b></p>	<p><b>Use the power log lift to load log onto the beam.</b></p> <p><b>NOTE:</b> You can also load logs manually onto the beam. However, note that musculoskeletal injury can result from lifting logs onto the log splitter if proper lifting techniques are not used or the logs are too heavy for a person's size, weight, or strength. In some cases, logs as small as 8" in diameter and 14" in length may be heavier than what some persons should be repeatedly lifting onto the splitter.</p> <p>The use of the power log lift can greatly reduce the need to lift logs. Employers are advised to consider NIOSH lifting guidelines when assigning employees to log splitting tasks for an extended period of time.</p>

# Splitting Operation

## Instructions for operating the power log lift:

### **⚠️WARNING: Crush hazard**

- **Operator position.** Stay in the designated OPERATOR position while operating log lift control.
  - **Second person.** If a helper is assisting in loading logs to be split, do not actuate log lift control until the helper is at least 10 feet away.
  - **Hand activate.** Use only your hand to operate the log lift control. Never use any other body part, or a rope, cable, or other remote device to actuate the control.
- 1) **Lower the log lift** by pushing the Lift and Split Control Lever away from you while standing in the designated OPERATOR position.

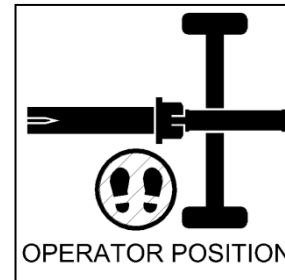
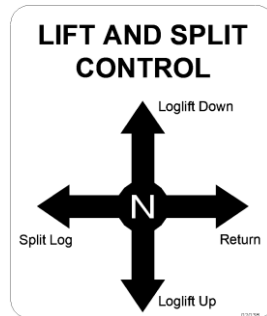

- 2) **Load log onto log lift.**
- 3) **Raise the log lift** by pulling the Lift and Split Control Lever toward you while standing in the designated OPERATOR position.

Important: If a hazardous situation is encountered at any time during the lifting operation, release the Lift and Split Control Lever and the log lift will stop moving

- 4) **Stop lift movement** by releasing the Lift and Split Control Lever.
- 5) **Allow log to roll onto beam.**

If log is oddly shaped, it may not roll down the log lift by itself. If this happens, walk around the log splitter to the log lift side and move the log onto the beam by hand.

### **⚠️WARNING: Crush hazard**

- Keep hands clear while log is rolling onto the beam.
- NEVER reach across the beam to move a log off the log lift onto the beam – the controls could be accidentally activated.

## 5. Load log

**Load log onto beam with a cut end against the wedge – positioned for a lengthwise cut.**

### NOTES:

- a. The log splitter is designed only for cutting lengthwise with the grain, NOT for cutting across the grain.
- b. This log splitter is designed for cutting logs only up to a maximum of 24" in diameter and 30" long. Larger diameter logs could get stuck on the wedge and longer logs will not fit on the beam.

# Splitting Operation

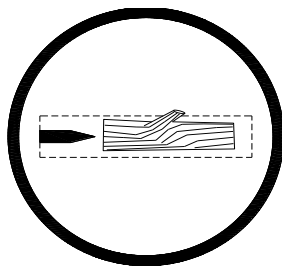

**Correct Log Orientation**

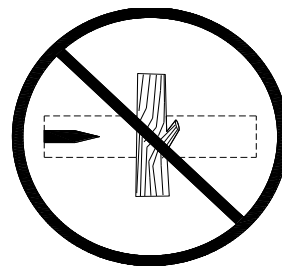

**Incorrect Log Orientation**

**⚠ WARNING:** ALWAYS keep hands and feet away from the ram, wedge, and partially split logs while loading, operating and unloading the log splitter.

**Important safety instructions:**

- **Hold bark side.** Hold the bark side of logs when loading or positioning, never the ends. Never place your hands or any part of your body between a log and any part of the log splitter.
- **Ram moving.** NEVER load or unload while the ram is moving.
- **Straddling / reaching across.** Never straddle, reach across, or step over the beam while the engine is running and the log splitter is in the horizontal position. You could trip, actuate the controls, and get seriously injured.
- **Unsplit log pile.** Do not pile logs to be split in a place that will make you reach across the log splitter in order to load them.
- **Square log ends.** Logs that are not cut square can slide out while splitting and become a safety hazard or cause excessive force to log splitter components. Use a chainsaw to cut logs square on each end before attempting to split them.
- **Single log.** Never attempt to split more than one log at a time. Pieces of log can unexpectedly be thrown from the machine causing serious injury.
- **Split along grain.** Do not use the log splitter to split logs across the grain. Doing so will damage the log splitter and could also cause pieces of log to be thrown, injuring the operator or bystanders.

**6. Position 4-way wedge**

**Position the wedge for a 2-way or 4-way split.**

You can adjust the wedge for a 2-way or 4-way split. When the wedge is raised, it will make a 4-way split. When the wedge is lowered, it will make a 2-way split.

1. Raise the wedge for a 4-way split by pulling the Wedge Control UP.

**Important:** Do not attempt a 4-way split on forked logs. They can be extremely hard to split and can get stuck on the 4-way wedge. Only split-forked logs with the 2-way wedge completely down.

2. Lower the wedge for a 2-way split by pushing the Wedge Control Down.

**⚠ WARNING: Pinch hazard**

The 4-way wedge and cam mechanism can pinch fingers and toes. When lowering wedge, keep hands and feet clear of the wedge, the area directly below wedge, and the cam mechanism.

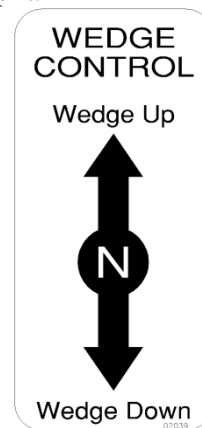

# Splitting Operation

## 7. Extend ram

Move Split Control Lever toward wedge to extend ram and split log.

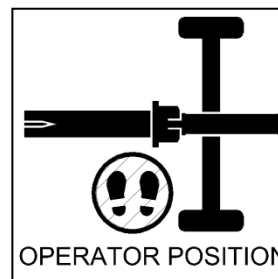
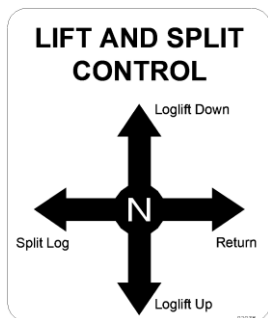

**Important safety instructions:**

- **Operator position.** ALWAYS operate the log splitter from the manufacturer's indicated OPERATOR POSITION. (See diagram above.) Other positions are unsafe because they can increase the risk of injury from crushing, cutting, flying objects, or burns.
- **Remove hands.** Remove both hands from log before activating Split Control Lever.
- **Hand activate.** Use only your hand to operate the Split Control Lever. Never use any other body part, or a rope, cable, or other remote device to actuate the control.
- **Second person.** Many accidents occur when there is more than one person involved in loading and operating the log splitter. Only one person should operate the controls. If a second person is assisting in loading logs, the operator must NEVER actuate the Split Control Lever until the assistant and all bystanders are at least 10 feet away. NEVER allow an assistant to hold the log in place while the operator actuates the Split Control Lever.

## 8. Stop ram

Release Split Control Lever to stop ram movement when log is split.

**⚠WARNING:** Cracks in logs can close quickly and pinch fingers. Keep fingers away from any cracks that open in partially split logs.

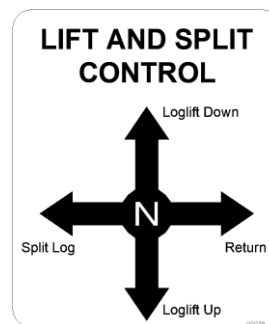

## 9. Important STUCK LOG procedure

**If a log does not split completely and becomes stuck on the wedge, follow the instructions below to remove the log.**

A log can become stuck to the wedge if the wedge becomes embedded in the log and the log doesn't split and separate. This can happen if the log is too stringy or tough to split completely.

If this happens, follow the directions below.

- ⚠WARNING: NEVER** attempt to remove a stuck log by:
- Using the hydraulic force of the splitter.
  - Modifying the splitter.
  - Adding attachments to the splitter.

Personal injury could result from log or metal pieces flying out at high speed toward the operator or bystanders, or the splitter could become damaged.

# Splitting Operation

- 1) Retract ram fully.
- 2) Turn engine OFF.
- 3) Remove stuck log from the wedge **manually** with a pry bar or a sledgehammer.
  - **Important:** Be extremely careful as log pieces may fly off as they separate from the wedge. Make sure bystanders are clear and wear safety goggles.
- 4) Do not attempt to resplit a stuck log once it has been removed from the wedge. Manually split with an axe or cut with a chainsaw.

## 10. Return ram

**Move Split Control Lever away from wedge to return ram.**

Once the control valve is actuated in the return direction, the ram is designed to keep returning by itself completely and then stop automatically.

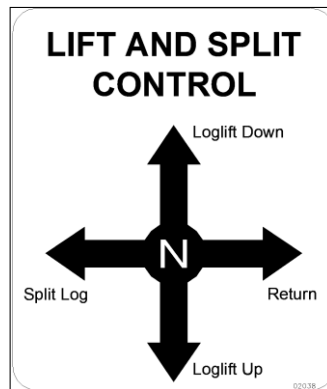

### **⚠WARNING:**

Stay clear while the ram is returning. It is still powerful enough on the return stroke to cause serious injury.

## 11. Remove split wood

**Remove split wood from area.**

Move each log away from log splitter after it is split. Split logs left near the log splitter are a trip hazard.

## 12. After use.

1. **Turn off engine.**
2. **Remove engine debris.**

Debris on a hot engine can be a fire hazard. After the engine is off, clean debris and chaff from engine cylinder head, cylinder head fins, blower housing rotating screen, and muffler areas.



**⚠WARNING:** Avoid contact with hot muffler.

# Storage

## **WARNING**

Gasoline vapors can ignite and cause a fire. Select a well-ventilated storage area away from sources of heat, flame, or sparks.

Follow the instructions below for storing your log splitter between uses.

<b>1. Retract wedge</b>	<b>Retract the wedge completely to keep the rod protected from corrosion.</b>
<b>2. Cool</b>	<p><b>Allow the machine to cool 5 minutes before storing.</b></p> <p><b> WARNING:</b> A hot engine can be a fire hazard.</p>
<b>3. Wipe with oily rag</b>	<b>Wipe the beam and wedge with an oily rag to prevent corrosion.</b>
<b>4. Engine manual</b>	<p><b>Refer to the engine manual for proper engine storage instructions.</b></p> <p><b>CAUTION:</b> Gasoline will oxidize and deteriorate in storage. Old gasoline in the engine will cause hard starting and leave gum deposits that can clog the fuel system. Deterioration problems may occur within a few months, or even less if gasoline was not fresh when you filled the fuel tank.</p> <p><b><u>Short-Term Storage:</u></b></p> <ol style="list-style-type: none"> <li>1. Consider adding a fuel stabilizer to extend fuel storage life.</li> <li>2. Leave the fuel valve lever in the OFF position to reduce the possibility of fuel leakage.</li> </ol> <p><b><u>Long Term Storage:</u></b> (between infrequent uses and at end of season)</p> <p>Drain the fuel tank and carburetor as instructed in the engine owner's manual.</p> <p><b><u>Important Safety Instructions:</u></b></p> <ul style="list-style-type: none"> <li>• Always drain fuel from tank in outdoor, well-ventilated area.</li> <li>• Stay away from sources of heat, flame, or sparks while handling fuel.</li> <li>• Clean up fuel spills/splashes immediately.</li> </ul>
<b>5. Splitter storage location</b>	<p><b>Store the log splitter in a location away from corrosive material, sources of heat, open flames, sparks or pilot lights.</b></p> <p><b> WARNING:</b> Never store log splitter inside where there is a source of heat or an open flame, spark, or pilot light – such as water heaters, space heaters, furnaces, clothes dryers, or other gas appliances. Even if the log splitter's gas tank is empty, residual gasoline vapors could ignite.</p> <p><b>NOTE:</b> Do not store the log splitter near fertilizer or any other corrosive material.</p>
<b>6. Gasoline storage</b>	<p><b>Store gasoline in a cool, dry place in an UL listed, tightly sealed container.</b></p> <p><b> WARNING:</b> Gasoline vapors can ignite if they collect inside an enclosure and explosion can result.</p>

# Periodic Maintenance

In addition to the maintenance performed with each use, periodic maintenance should also be performed according to the following schedule.

## ⚠ WARNING

ALWAYS shut off the engine, disconnect the spark plug, and relieve system pressure before cleaning, adjusting, or repairing the splitter. Relieve system pressure by moving Split Control Lever back and forth several times.

### **IMPORTANT:**

If a part needs replacement, only use parts that meet the manufacturer's specifications. Replacement parts that do not meet specifications may result in a safety hazard or poor operation of the log splitter.

<b>1. Engine maintenance</b>	<b>Perform engine maintenance as specified in the engine owner's manual</b>
<b>2. Hydraulic oil change</b>	<p><b>Change hydraulic oil annually or every 100 hours.</b></p> <p><b>⚠WARNING:</b> High fluid pressures and temperatures are developed in hydraulic log splitters. Hydraulic fluid escaping through a pin hole sized opening can burn or puncture skin, resulting in wounds that could cause blood poisoning, infection, disability, gangrene, amputation, or death. Therefore, the following instructions should be heeded at all times when inspecting or servicing the hydraulic components of the log splitter:</p> <ul style="list-style-type: none"> <li>• NEVER check for leaks with your hand. Leaks can be located by holding a piece of cardboard or wood (at least two feet long) with your hand at one end and passing the other end over the suspected area (wear eye protection). Look for discoloration of the cardboard or wood.</li> <li>• NEVER adjust the pressure setting of the pump or valve.</li> <li>• If injured by escaping fluid, no matter how small the wound is, see a doctor at once. A typical injection injury may be a small puncture wound that does not look serious. However, severe infection or reaction can result if proper medical treatment is not administered immediately by a doctor who is familiar with injection injuries.</li> </ul> <ol style="list-style-type: none"> <li><b>1. Use 10 wt AW32, ASLE H-150, or ISO32 oil.</b></li> <li><b>2. Relieve hydraulic system pressure by moving Split Control Lever back and forth several times.</b></li> <li><b>3. Remove hydraulic oil fill cap.</b> <p style="margin-left: 20px;"><b>⚠WARNING:</b> NEVER remove the hydraulic oil fill cap when the engine is running or hot. Hot oil can escape causing severe burns. Allow log splitter to cool completely before removing hydraulic oil fill cap.</p> </li> <li><b>4. Remove the suction hose from the hydraulic tank to drain the hydraulic oil.</b></li> <li><b>5. Fill to “High” mark on the hydraulic tank gauge.</b></li> <li><b>6. Remove the spark plug wire from the spark plug</b></li> <li><b>7. Pull on the starter grip recoil at least 20 times so that hydraulic fluid has cycled through the pump</b></li> <li><b>8. Return the spark plug wire to the spark plug</b></li> <li><b>9. Dispose of used oil at an oil recycling center. Used hydraulic oil is hazardous waste.\</b></li> </ol>
<b>3. Spark arrestor muffler</b>	<p><b>If the engine is equipped with a spark arrestor muffler, clean and inspect it regularly (follow manufacturer's service instructions).</b></p> <p>Replace if damaged.</p>

# Troubleshooting

## ⚠ WARNING

Before troubleshooting or attempting to service, read the following safety instructions to avoid serious injury to the operator or bystanders from moving parts that can crush or cut, burns, fire or explosion, or escaping high pressure hydraulic fluid.

### **Important Safety Instructions:**

1. **Engine off.** Always make sure the engine is off before cleaning, repairing or adjusting the splitter, except as recommended by the manufacturer.
2. **Hydraulic safety.** High fluid pressures and temperatures are developed in hydraulic log splitters. Hydraulic fluid escaping through a pin hole sized opening can burn or puncture skin, resulting in wounds that could cause blood poisoning, infection, disability, gangrene, amputation, or death. Therefore, the following instructions should be heeded at all times when inspecting or servicing the hydraulic components of the log splitter:
  - Stop the engine, disconnect the spark plug, and move all control valve handles back and forth to relieve pressure before changing or adjusting hydraulic system components such as hoses, tubing, fittings or other components.
  - Do not remove the hydraulic oil fill cap when the engine is running. Hot oil can escape causing severe burns. Allow log splitter to cool completely before removing hydraulic oil fill cap.
  - Do not adjust the pressure setting of the pump or valve
  - NEVER check for leaks with your hand. Leaks can be located by holding a piece of cardboard or wood (at least two feet long) with your hand at one end and passing the other end over the suspected area (wear eye protection). Look for discoloration of the cardboard or wood.
  - If injured by escaping fluid, no matter how small the wound is, see a doctor at once. A typical injection injury may be a small puncture wound that does not look serious. However, severe infection or reaction can result if proper medical treatment is not administered immediately by a doctor who is familiar with injection injuries.

Problem	Solution
Ram will not move	Solution: A,D,E,H,J
Slow ram speed when extending or retracting	Solution: A,B,C,H,I,K
Wood will not split or splits extremely slowly	Solution: A,B,C,F,I,K
Engine bogs down during splitting	Solution: G
Engine stalls under low load condition	Solution: D,E
Engine will not start	Solution: L,M
Cause	Solution
<b>A</b> - Insufficient oil to pump	Check oil level in reservoir
<b>B</b> - Air in oil	Check oil level in reservoir, check for leaks in the suction line
<b>C</b> - Excessive pump inlet vacuum	Check pump inlet hose for blockage or kinks
<b>D</b> - Blocked hydraulic lines	Flush and clean the splitter hydraulic system
<b>E</b> - Blocked control valve	Flush and clean the splitter hydraulic system
<b>F</b> - Low control valve setting	Adjust control valve with a pressure gauge
<b>G</b> - High control valve setting	Adjust control valve with a pressure gauge
<b>H</b> - Damaged control valve	Return control valve for authorized repair
<b>I</b> - Internal control valve leak	Return control valve for authorized repair
<b>J</b> - Damaged cylinder piston	Return cylinder for authorized repair
<b>K</b> - Internally damaged cylinder	Return cylinder for authorized repair
<b>L</b> - Kill switch is in the off position	Turn to the run position
<b>M</b> - Problem with engine	Refer to your Engine Manual

**Any Questions, Comments, Problems, or Parts Orders**

***Call NorthStar Product Support 1-800-270-0810***

## Specifications

Maximum Pressure .....	3000 PSI
Maximum Flow .....	28 gpm
Hydraulic Fluid Capacity.....	28 gallons
Hydraulic Fluid Type.....	10 wt AW32, ASLE H-150, or ISO32
Coupler Size.....	2" Ball
Maximum Towing Speed.....	45 MPH
Maximum Log Length .....	30 in
Maximum Log Diameter.....	24 in
Maximum Log Weight .....	660 lbs.
Pressure Relief Setting .....	3000 PSI
Hydraulic Cylinder Bore .....	6 in
Hydraulic Cylinder Stroke .....	30 in
Spark Arrestor.....	Yes
Fuel Valve.....	No
Battery Requirements.....	12 volt, 18 Amp hour
Overall Dimensions .....	122" L x 76.25" W x 52" H
Dry Weight .....	2,435 LB

The manufacturer reserves the right to make improvements in design and/or changes in specifications at any time without incurring any obligation to install them on units previously sold.

**Any Questions, Comments, Problems or Parts Orders**  
***Call NorthStar Product Support 1-800-270-0810***

# Parts Breakdown – Exploded View 11967 Rev K

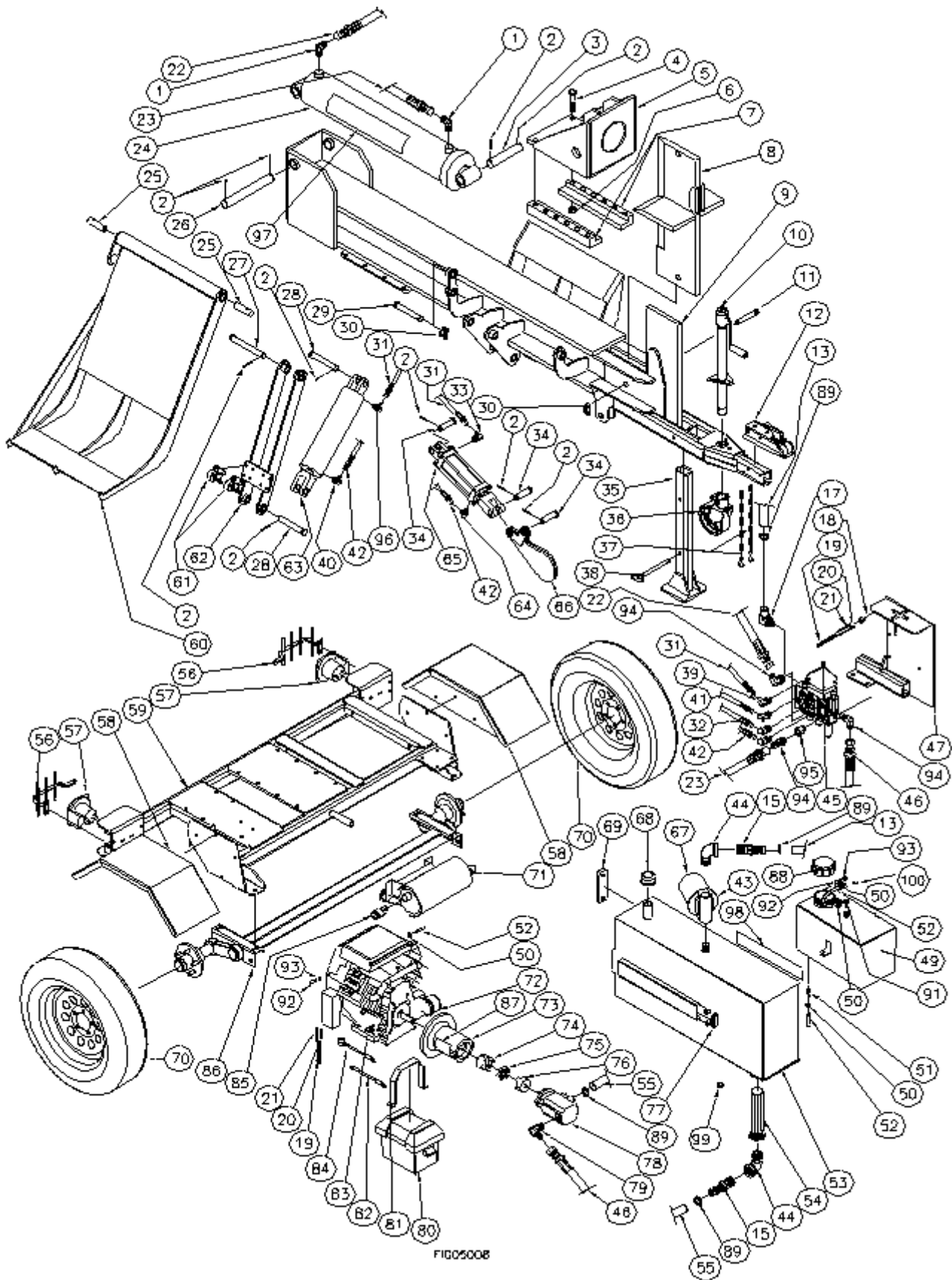

## Parts Breakdown – Exploded View 11967 Rev K

ITEM	PART#	DESCRIPTION	QTY	ITEM	PART#	DESCRIPTION	QTY
1	39164	3/4" NPT x JIC #12 Elbow	2	53	791180	Hydraulic Tank	1
2	82140	1/8"x 2" Cotter Pin	10	54	39188	Suction Strainer	1
3	38981	1-1/2" x 7-3/4" Pin	1	55	36130	1-1/4" Black Hose	1
4	82240	3/4"-10 x 3-3/4" Hex Bolt Gr. 8	12	56	789558	Tail Light Guard	2
5	38891	Beam Slide	1	57	789590	Light w/ Wire Harness	1
6	82247	3/4"-10 Hex Nut Grade 8	12	58	38941	Fender	2
7	38895	Keepers	2	59	789582	Sub Frame	1
8	39093	4 Way Wedge	1	60	38898	Log Lift	1
9	803107	Beam	1	61	189900	Steel Roller	2
10	796875	A-Frame Jack	1	62	38906	Lift Arm	1
11	777919	4 Way Wedge Travel Pin	1	63	788105	3" x 12" Cylinder	1
12	38587	2" Coupler	1	64	50E86	JIC #6 x #8 ORB Elbow	1
13	36130	1-1/4" Black Hose	1	65	39160	2.5" x 6" Cylinder	1
15	777846	1-1/4" King Nipple	2	66	39089	Cam	1
17	791063	16MOR x 1-1/4" HB Elbow	1	67	791248	Replacement Filter	1
18	777855	Engine Kill Switch	1	68	405A	Breather Cap	1
19	30501	1/4" Conduit	78"	69	4066	Hydraulic Oil Level Gauge	1
20	39034	Kill Switch Wire (Black)	1	70	780200	15" White Spoke Wheel	2
21	39033	Kill Switch Wire (White)	1	71	783395	Muffler	1
22	39047	3/4" x 66" Hydraulic Hose	1	72	783394	Honda GX630 Engine	1
23	39046	3/4" x 90" Hydraulic Hose	1	73	779684	Pump Bracket – 3042	1
24	790759	6" x 30" Cylinder	1	74	777798	1" Coupling	1
25	38983	1" x 4" Pin with Hole	2	75	778744	Rubber Insert	1
26	38982	1.5" x 11-7/8" Pin	1	76	778743	5/8" Coupling	1
27	406510	1" x 8" Pin	1	77	35012	Trim Lock	30"
28	37878	1" x 6" Pin	2	78	39156	28 GPM Pump	1
29	777918	Travel Pin	1	79	39172	1" NPT x JIC #12 Elbow	1
30	39159	Lynch Pin	2	80	777352	Battery Box	1
31	39051	3/8" x 105" Hydraulic Hose	2	81	38945	Battery Strap	1
33	781733	Flow Reducer Elbow	1	82	777108	Negative Battery Cable	1
34	406518	1" x 3-1/4" Pin	3	83	777110	1/2" Hose Clip	1
35	803109	Leg	1	84	32839	Positive Battery Cable	1
36	799561	Wheel For Jack	1	85	39169	Spark Arrestor	1
37	1130	Safety Chain	2	86	39166	Torsion Axle	1
38	803106	5/8" x 7" Pin w/ Bridge Pin	1	87	779682	Guard Insert for Pump Bracket	2
39	789050	10MOR x JIC #6 Elbow	4	88	784769	Sealed Fuel Cap	1
40	5018	1/2" x JIC #6 Elbow	1	89	781700	1-3/4" T-bolt Clamp	4
42	777356	3/8" x 116" Hydraulic Hose	2	91	783212	1/4" x 1/4" Hose Barb Elbow	1
43	791245	Return Line Filter Head	1	92	801491	Hose, 3/8" Fuel Line	6"
44	39315	1-1/4" Street Elbow	2	93	30746	3/8" Hose Clamp	2
45	791065	Control Valve	1	94	777366	Fitting, 1-1/16 x 1-1/16	3
46	39047	3/4" x 66" Hydraulic Hose	1	95	791064	12MOR x 12FOR Expander	1
47	38976	Valve Mount	1	96	788080	1/2" x JIC #6 Flow Reducer	1
49	806073	Fuel Assy(Tank includes 88,91)	1	97	790809	Decal, 42 Ton	2
50	777834	1/4" Hose Clamp	4	98	790776	Decal, NorthStar	1
51	777340	1/4" MPT x 1/4" Hose Barb	1	99	790064	Magnetic Drain Plug	1
52	801490	Hose, 1/4" Fuel Line	148.5"	100	785768	Hose Mender 3/8X1/4, Nylon	1

# Summary of Important Safety Information for Operation

## WARNING

Carefully read and make sure you understand the following safety information before using the log splitter.

Improper use or maintenance of the log splitter can result in serious injury to the operator or bystanders from moving parts that can crush or cut, flying objects, escaping high pressure hydraulic fluid, or carbon monoxide poisoning.

### Introduction

- **Read manual.** Read this Operator's Manual and the engine Owner's Manual completely before attempting to use the log splitter. Serious injury or death can result if safety instructions are not followed.
- **Instruct operators.** The log splitter owner should instruct all operators in safe log splitter operation.
- **Intended use.** Log splitters should only be used for splitting wood logs, lengthwise with the grain. Do not use for other purposes, as unforeseen hazards may result.

### Prohibition Against Modifications

Never modify or alter the log splitter in any way. Modifications can create serious safety hazards and will void the warranty.

- **Attachments.** Never add attachments to the splitter, except for authorized accessories supplied by the manufacturer with instructions for safe installation and use.
- **Engine speed.** The maximum engine speed is preset at a safe limit. Never attempt to modify the engine speed setting to run at a higher speed.
- **Fuel/exhaust system.** NEVER modify or add to the exhaust system, fuel tanks, or fuel lines. Fire can result
- **Remote control.** NEVER attach a rope, cable, or other remote device to the splitting control.
- **Splitting wedge.** NEVER attempt to change the height or speed of the splitting wedge.
- **Pressure setting.** NEVER increase the pressure setting of the pump or control valve.

### Operator Restrictions

- **Untrained operators.** Do not allow anyone to operate the log splitter who has not read the Owner's Manual or been instructed on the safe use of the splitter.
- **Minimum operator age.** Never allow anyone under 16 years old to operate the log splitter. Children 16 years and older must be trained and supervised by a trained adult.

### Safety in Moving and Towing the Log Splitter

## WARNING

The log splitter is very heavy. It can crush and cause serious injury if it rolls out of control or tips over.

Follow the instructions below for safely moving and towing the log splitter.

### General Safety While Moving

- **Log lift raised upright.** Make sure the log lift is raised to its full upright (vertical) position before moving the splitter. DO NOT move the log splitter when the log lift is down because it will be unbalanced and difficult to move, and the lifter is more likely to be damaged.
- **Hills.** Do not move the log splitter up or down hills by hand -- use a towing vehicle.
- **Engine off.** Never move the log splitter with its engine running.
- **No riding.** Never allow anyone to sit or ride on the log splitter.
- **No cargo.** Never transport cargo or wood on the log splitter.

# Summary of Important Safety Information for Operation

## Safety During Towing

- **Read instructions.** Review towing safety instructions in your towing vehicle manual.
- **Securely attached.** Be sure the log splitter is securely attached to the towing vehicle before towing.
- **Tires.** Be sure tires are fully inflated and in good repair before towing the splitter. When adding air to tires, do not over-inflate -- serious injury could occur if tire explodes.
- **Added length.** Be aware of the added length of the splitter.
- **Speed limit.** Never tow this log splitter over mph. Faster speeds may result in loss of control.
- **Rough terrain.** Be extra cautious and drive slowly when traveling over rough terrain.
- **Under the influence.** Never tow this splitter while under the influence of alcohol, drugs, or medication.
- **On public roads.** If towing on a public road, make sure to comply with all local, state, and federal towing requirements. It is the sole responsibility of the purchaser to obtain licensing, trailer lights, safety chains or signage, as needed to comply.
- **Unattended.** Turn off the towing vehicle before leaving the splitter unattended.
- **Disconnect before operate.** Do not use the log splitter while it is connected to the towing vehicle.

## Safety – Before Use

### Read/instruct

- **Read manual.** Do not allow anyone to operate the log splitter who has not read the Owner's Manual or has not been instructed on the safe use of the splitter.
- **Review safety rules.** Before starting this log splitter, review the instructions for safe operation. Failure to follow these instructions may result in serious injury to the operator or bystanders.
- **Know how to stop.** Be thoroughly familiar with all controls and with the proper use of the equipment. Know how to stop the log splitter and relieve system pressure quickly if needed.

## Personal protective equipment

- **Eye protection.** Always wear safety glasses or goggles when operating the machine. Pieces of log may fly out and serious eye injury can occur.
- **Boots.** Falling logs can crush feet. Always wear safety shoes or heavy boots when operating or helping to load logs.
- **Loose / dangling.** Loose or dangling apparel can become entangled in moving parts. Never wear jewelry or loose-fitting clothing.
- **Gloves.** Wear snug fitting gloves without drawstrings or loose cuffs.
- **Hearing protection.** The use of earplugs or other hearing protection device is recommended.

Batteries are hazardous because they contain caustic acid, can emit explosive gases, and can cause electric shock. *Caution must be exercised when making connections to a battery to avoid shock and contact with the acid, and to prevent any sparking that could lead to an explosion.* Follow safety rules carefully when connecting battery to log splitter.

- ALWAYS use eye protection when connecting/disconnecting battery.
- NEVER smoke or work near sparks or other sources of ignition.
- NEVER touch both battery terminals at the same time with your hand or any non-insulated tools.
- ALWAYS connect and disconnect cables to the correct battery terminals in the proper sequence:
  - When CONNECTING the battery, connect the RED cable to the POSITIVE terminal FIRST.
  - When DISCONNECTING the battery, disconnect the BLACK cable from the NEGATIVE terminal FIRST.
- If battery acid contacts skin or clothing, flush immediately with water and neutralize with baking soda.

## Safety During Inspection/Maintenance

Always inspect your log splitter before each use, and repair as needed, to keep it in safe working condition:

- **Engine off.** Always make sure the engine is off before cleaning, repairing or adjusting the splitter, except as recommended by the manufacturer.

## Summary of Important Safety Information for Operation

- **Engine debris.** Debris on a hot engine can be a fire hazard. With the engine off, clean debris and chaff from engine cylinder head, cylinder head fins, blower housing rotating screen, and muffler areas. Avoid contact with hot muffler.
- **Other debris.** Debris on moving parts can cause excess wear. With the splitter engine off, clear debris from moving parts.
- **Fuel tank / lines.** Before each use, check fuel tank and fuel lines for leaks. Any fuel leak is a fire hazard. Fix any fuel leaks before starting engine.
- **Mechanical parts.** Check to be sure all nuts and bolts are tight to make sure the log splitter is in safe working condition.
- **Hydraulic system.** Check the hydraulic system (hoses, tubing, clamps/fittings, pump, and cylinder) carefully before each use. Do not operate the log splitter with frayed, kinked, cracked or damaged hydraulic hoses, fittings, or tubing, or if oily residue is observed on any of the components. High fluid pressures and temperatures are developed in the log splitter. Hydraulic fluid escaping through a pin hole sized opening can burn or puncture skin, resulting in wounds that could cause blood poisoning, infection, disability, gangrene, amputation, or death. Therefore, the following instructions should be heeded at all times when inspecting or servicing the hydraulic components of the log splitter:
  - Do not remove the hydraulic oil fill cap when the engine is running. Hot oil can escape causing severe burns. Allow log splitter to cool completely before removing hydraulic oil fill cap.
  - Do not adjust the pressure setting of the pump or valve.
  - Do not check for leaks with your hand. Leaks can be located by holding a piece of cardboard or wood (at least two feet long) with your hand at one end and passing the other end over the suspected area (wear eye protection). Look for discoloration of the cardboard or wood.
  - Stop the engine, disconnect the spark plug, and move all control valve handles back and forth to relieve pressure before changing or adjusting hydraulic system components such as hoses, tubing, fittings or other components.
  - If injured by escaping fluid, no matter how small the wound is, see a doctor at once. A typical injection injury may be a small puncture wound that does not look serious. However, severe infection or reaction can result if proper medical treatment is not administered immediately by a doctor who is familiar with injection injuries.
- **Spark arrestor muffler.** If the engine is equipped with a spark arrestor muffler, clean and inspect it regularly (follow manufacturer's service instructions). Replace if damaged.
- **Tires.** Be sure tires are fully inflated and in good repair before towing the splitter. When adding air to tires, do not over-inflate -- serious injury could occur if tire explodes.
- **Guards / shields.** Make sure all guards and shields are replaced after servicing the log splitter.
- **Replacement parts.** If a part needs replacement, only use parts that meet the manufacturer's specifications. Replacement parts that do not meet specifications may result in a safety hazard or poor operation of the log splitter

### Safety During Fueling

Gasoline is highly flammable and explosive. You can be burned or seriously injured when handling fuel. Use extreme care when handling gasoline:

- **Fuel outdoors.** Fill fuel tank outdoors – never indoors. Gasoline vapors can ignite if they collect inside an enclosure. Explosion can result.
- **Use approved container.** Never pump fuel directly into engine at gas station. Static charge can build and ignite fuel. Use a UL listed fuel container to transfer gas to the engine.
- **Running/hot engine.** A running engine is hot enough to ignite fuel. Never add fuel or remove gas cap if engine is running or still hot. Stop the engine and allow to cool at least two minutes before adding fuel.
- **Heat/flames/sparks.** Stay away from sources of heat, flame, or sparks while adding fuel.
- **Don't overfill.** DO NOT overfill the gas tank. Allow at least 1/2" of empty space below the fill neck to allow for fuel expansion.
- **Replace cap.** Replace gas cap securely before starting engine.
- **Spills.** Clean up fuel spills immediately. Move log splitter away from spilled fuel on the ground. Wipe fuel off engine and wait 5 minutes for excess fuel to evaporate before starting engine. Gas soaked rags should be disposed of properly.

## Summary of Important Safety Information for Operation

- **On skin / clothes.** If gasoline is spilled on your skin or clothes, change clothes and wash skin immediately.
- **Gasoline storage.** Store gasoline in a cool, dry place in an UL listed, tightly sealed container.

### Safety in Work Site Selection / Set-up

- **Spark arrestor.** If your splitter will be used near any unimproved forest, brush, or grassy covered land, then engine should be equipped with a spark arrestor. See the "Specifications" section of this manual to determine if your splitter already has a spark arrestor. Make sure you comply with applicable local, state and federal codes
- **Hot exhaust.** Hot exhaust fumes from engine can cause fire. Position muffler at least 7 feet from combustible objects during operation
- **Fire extinguisher.** Have a Class B fire extinguisher available as a precautionary measure when operating the log splitter in dry areas.
- **Level, dry surface.** To prevent accidental falls and equipment tip over, make sure the splitter is situated on a dry, level surface with good footing. Stay clear of areas with mud, ice, tall grass, weeds, or brush.
- **Block wheels.** Always block the wheels to prevent unintended movement of the log splitter.
- **Carbon monoxide.** The running engine gives off carbon monoxide, a poisonous gas that can kill you. You CANNOT smell it, see it, or taste it. ONLY run log splitter OUTDOORS and at least 20 feet from the home, away from windows, vents and air intakes, to allow proper ventilation. NEVER run log splitter inside homes, garages, sheds, or other semi-enclosed spaces. These spaces can trap poisonous gases, EVEN if you run a fan or open windows. If you start to feel sick, dizzy, or weak while using the log splitter, shut off the engine and get to fresh air RIGHT AWAY. See a doctor. You may have carbon monoxide poisoning.

### Safety – During Use

#### General Safety During Use

**⚠ WARNING:** Before starting this log splitter, review the following rules for safe operation. Failure to follow these rules may result in serious injury to the operator or bystanders.

- **Safety equipment / controls.** Always operate the log splitter with all safety equipment in place and in good working order, and all controls properly adjusted for safe operation.
- **Operating speed.** Always operate the log splitter at the manufacturer's recommended speed. The maximum speed of the engine, pump and ram are preset within safe limits.
- **Know how to stop.** Be thoroughly familiar with all controls and with the proper use of the equipment. Know how to stop the log splitter and relieve system pressures quickly if needed.
- **Daylight only.** Only use the log splitter in daylight so you can see what you are doing.
- **Smoking / sparks.** Never smoke while operating the log splitter, and never operate near sources of sparks or flames.
- **Hot muffler.** If you are starting a warm engine, stay clear of muffler. It may still be hot enough to burn you.
- **Unattended.** Never leave the machine unattended while the engine is running.
- **Under the influence.** Never operate, or let anyone else operate, the log splitter while under the influence of alcohol, drugs, or medication.
- **Adjusting / repairing.** Always make sure the engine is off before cleaning, repairing or adjusting the splitter, except as recommended by the manufacturer. In addition, disconnect the spark plug and move all control handles back and forth to relieve system pressure *before changing or adjusting hydraulic system components* such as hoses, tubing, fittings or other components.
- **Carbon monoxide.** The running engine gives off carbon monoxide, a poisonous gas that can kill you. You CANNOT smell it, see it, or taste it. If you start to feel sick, dizzy, or splitter, shut off the engine and get to fresh air RIGHT AWAY. See a doctor. You may have carbon monoxide poisoning while using the log splitter.
- **Other exhaust dangers.** Engine exhaust, some of its constituents, and certain vehicle components contain or emit chemicals known to the State of California to cause cancer, birth defects, or other reproductive harm. Avoid inhalation of exhaust.

# Summary of Important Safety Information for Operation

## Safety in Loading, Operating, and Unloading

- **Square log ends.** Logs that are not cut square can slide out while splitting and become a safety hazard or cause excessive force to log splitter components. Use a chainsaw to cut logs square on each end before attempting to split them.
- **Single log.** Never attempt to split more than one log at a time. Pieces of log can unexpectedly be thrown from the machine causing serious injury.
- **Split along grain.** Do not use the log splitter to split logs across the grain. Doing so will damage the log splitter and could also cause pieces of log to be thrown, injuring the operator or bystanders.
- **Keep hands clear.** ALWAYS keep hands and feet away from the ram, wedge, and partially split logs while loading, operating and unloading the log splitter.
- **Operator position.** ALWAYS operate the log splitter from the manufacturer's indicated OPERATOR POSITION. Other positions are unsafe because they can increase the risk of injury from crushing, cutting, flying objects, or burns.
- **Straddling / reaching across.** Never straddle, reach across, or step over the beam while the engine is running and the log splitter is in the horizontal position. You could trip, actuate the controls, and get seriously injured.
- **Second person.** Many accidents occur when there is more than one person involved in loading and operating the log splitter. Only one person should operate the controls. *If a second person is assisting in loading logs, the operator must NEVER actuate the Split Control Lever until the assistant and all bystanders are at least 10 feet away. NEVER allow an assistant to hold the log in place while the operator actuates the Split Control Lever.*
- **Loading/Unloading**
- **Unsplit log pile.** Do not pile logs to be split in a place that will make you reach across the log splitter in order to load them.
- **When operating log lift:**
  - Stay in the designated OPERATOR position while operating log lift control.
  - If a helper is assisting in loading logs to be split, do not actuate log lift control until the helper is at least 10 feet away.
  - Use only your hand to operate the log lift control. Never use any other body part, or a rope, cable, or other remote device to actuate the control.
  - Keep hands clear while log is rolling onto the beam.
  - NEVER reach across the beam to move a log off the log lift onto the beam -- the controls could be accidentally be activated. If a log is oddly shaped and does not roll down onto the beam by itself, walk around the log splitter to the log lift side and move the log onto the beam by hand.
- **Hold bark side.** Hold the bark side of logs when loading or positioning, never the ends. Never place your hands or any part of your body between a log and any part of the log splitter.
- **Ram moving. NEVER load or unload logs while the ram is moving.**
- **Cracks.** Cracks in logs can close quickly and pinch fingers. Keep fingers away from any cracks that open in partially split logs.
- **Split log pile.** Move each log away from log splitter after it is split. Split logs left near the log splitter are a trip hazard.
- **Forked logs.** Do not attempt a 4-way split on forked logs. They can be extremely hard to split and can get stuck on the 4-way wedge. Only split forked logs with the 2-way wedge completely down.
- **Keep hands clear when lowering wedge.** The 4-way wedge and cam mechanism can pinch fingers and toes. When lowering the wedge, keep hands and feet clear of the wedge, the area directly below wedge, and the cam mechanism.
- **Remove hands.** Remove both hands from log before activating Split Control Lever.
- **Hand activate.** Use only your hand to operate the Split Control Lever. Never use any other body part, or a rope, cable, or other remote device to actuate the control.
- **Returning ram.** Once the control valve is actuated in the return direction, the ram is designed to keep returning by itself completely and then stop automatically. Stay clear while the ram is returning. It is still powerful enough on the return stroke to cause serious injury.

## Summary of Important Safety Information for Operation

- **Log stuck on wedge.** A log can become stuck to the wedge if the wedge becomes embedded in the log and the log doesn't split and separate. This can happen if the log is too stringy or tough to split completely. If this happens, follow the directions below to manually remove the log:

**IMPORTANT:** NEVER attempt to remove a stuck log by using the hydraulic force of the splitter, or by modifying or adding attachments to splitter. Personal injury could result from log or metal pieces flying out at high speed toward the operator or bystanders, or the splitter could become damaged.

1. Retract ram fully.
  2. Turn engine OFF.
  3. Remove stuck log from the wedge **manually** with a pry bar or a sledgehammer. Be extremely careful, as log pieces may fly off as they separate from the wedge. Wear safety goggles and make sure bystanders are clear.
  4. Do not attempt to resplit a stuck log once it has been removed from the wedge.
- **Refueling.** Never refuel the engine until it has cooled at least two minutes.

### Safety – After use

- **Remove engine debris.** Debris on a hot engine can be a fire hazard. With the engine off, clean debris and chaff from engine cylinder head, cylinder head fins, blower housing rotating screen, and muffler areas. Avoid contact with hot muffler.
- **Let engine cool before storing.** Let engine cool for at least five minutes before storing. A hot engine can be a fire hazard.
- **Storage location.** Store the log splitter in a location away from sources of heat, open flames, sparks or pilot lights – such as water heaters, space heaters, furnaces, clothes dryers, or other gas appliances. Even if the log splitter's gas tank is empty, residual gasoline vapors could ignite.
- **Gasoline storage.** Store extra gasoline in a cool, dry place in an UL approved, tightly sealed container. Gasoline vapors can ignite if they collect inside an enclosure.
- **Periodic maintenance.** Perform periodic maintenance as directed in this manual to keep the log splitter in safe working condition.

# Limited Warranty

Dear Valued Customer:

The NorthStar Product you just purchased is built with the finest material and craftsmanship. Use this product properly and enjoy the benefits from its high performance. By purchasing a NorthStar product, you show a desire for quality and durability. Like all mechanical equipment this unit requires a due amount of care. Treat this unit like the high quality piece of machinery it is. Neglect and improper handling may impair its performance. Please thoroughly read the instructions and understand the operation before using your product. Always contact NorthStar Product Support at 1-800-270-0810 prior to having any service or warranty work performed, as some services performed by parties other than NorthStar approved service centers may void this warranty. This warranty is in lieu of any other warranty expressed or implied and NorthStar assumes no other responsibility or liability outside that expressed within this warranty.

## Limited Warranty

NorthStar shall warranty any piece of equipment manufactured, or parts of equipment manufactured, to be free from defects in material or workmanship for a period of:

<b>NorthStar Warranty</b>		
<b>Item #</b>	<b>Consumer Warranty Period</b>	<b>Commercial Warranty Period</b>
11967	4 years from date of purchase by user	1 year from date of purchase by user

<b>Engine Warranty</b>		
<b>Item #</b>	<b>Consumer Warranty Period</b>	<b>Commercial Warranty Period</b>
11967	3 years from date of purchase by user	3 years from date of purchase by user

“Consumer use” means personal residential household use by a consumer. “Commercial use” means all other uses, including use for commercial, income producing or rental purposes or when purchased by a business.

This warranty applies to the original purchaser of the equipment (verification of purchase, in the form of a receipt, is the responsibility of the buyer), is non-transferable, and covers parts and labor. Parts will be replaced or repaired at no charge, except when the equipment has failed due to lack of proper maintenance. If a part is no longer available, the part may be replaced with a similar part of equal function. Any misuse, abuse, alteration or improper installation or operations will void warranty. Determining whether a part is to be replaced or repaired is the sole decision of NorthStar. NorthStar will not provide for replacement of complete products due to defective parts. Any costs incurred due to replacement or repair of items outside of a NorthStar approved facility is the responsibility of the buyer and not covered under warranty. Transportation costs to and from service center is the responsibility of the customer.

In addition to the normal warranty, NorthStar shall warrant any normal wear item from defects in material or workmanship for a period of 90 days from the date of purchase by user. Normal wear items include, but are not limited to, tires and filter elements.

This warranty specifically excludes the following; failure of parts due to damage caused by accident, fire, flood, windstorm, acts of God, applications not approved by NorthStar in writing, corrosion caused by chemicals, use of replacement parts which do not conform to manufacturer’s specifications, damage related to rodent and/or insect infestation and damage caused by vandalism. Additional exclusions: loss of running time, inconvenience, loss of income, or loss of use, including any implied warranty of merchantability of fitness for a specific use. Also, Outdoor Power Equipment needs periodic parts and service to perform well, and this warranty does not cover instances when normal use has exhausted the life of a component or the engine.

This warranty does not cover any personal injury or damage to surrounding property caused by failure of any part. Repair or replacement of parts does not extend the warranty period.

The engine warranty is covered under the terms and conditions as outlined by the engine manufactures warranty contained herein and is the sole responsibility of the engine manufacture. Normal engine maintenance such as spark plugs, air filters, adjustments, fuel system cleaning and obstruction due to build up is not covered by this NorthStar warranty.

Please fill in the following information and have it on hand when you call in on a warranty claim.

Customer Number: \_\_\_\_\_

Date of Purchase: \_\_\_\_\_

NorthStar Serial Number: \_\_\_\_\_

Item Number: \_\_\_\_\_

*This page has intentionally been left blank.*

**⚠️ WARNING:** This product can expose you to chemicals including gasoline engine exhaust, which is known to the State of California to cause cancer, and carbon monoxide, which is known to the State of California to cause birth defects or other reproductive harm.

For more information go to [www.P65Warnings.ca.gov](http://www.P65Warnings.ca.gov).



Manufactured by  
Northern Tool + Equipment Co., Inc.  
Burnsville, MN 55306  
NorthernTool.com