



POWERHORSE®

Owner's Manual

M11965B.6

ITEM NUMBER: 11965

SERIAL NUMBER: _____

Instructions for Assembly, Testing, Operation, Servicing, & Storage
Log Splitter: Outdoor hydraulic powered machine that splits wood logs.

⚠ WARNING

READ and UNDERSTAND this manual completely before using log splitter.

All operators of this equipment must read and completely understand all safety information, operating instructions, maintenance and storage instructions. Failure to properly operate and maintain the log splitter could result in serious injury to the operator and bystanders from moving parts that can crush or cut, flying objects, burns, fire or explosion, escaping high pressure hydraulic fluid, or carbon monoxide poisoning in particular, be aware of the following hazards.

Crush and Cut Hazards

Moving parts can crush and cut hands and fingers. Keep hands clear of endplate, wedge, logs, and log strippers while splitting.

High Pressure Hydraulic Fluid Hazards

High fluid pressures and temperatures are developed in hydraulic log splitters. Hydraulic fluid escaping through even a pin-size hole opening can puncture skin and cause severe blood poisoning. Inspect hydraulic system regularly for possible leaks. Never check for leaks with your hand while the system is pressurized. Seek medical attention immediately if injured by escaping fluid.

Fire Hazards

- Keep a fire extinguisher rated “ABC” nearby. Keep it properly charged and be familiar with its use.

STOP!

READ YOUR TRACTOR MANUAL TO DETERMINE HOW TO HOOK UP TO TRACTOR

ASSEMBLY REQUIRED: This product requires assembly before use. See “Assembly” section for instructions.

INSPECT COMPONENTS. Closely inspect upon receipt to make sure no components are missing or damaged. See “Assembly” section for instructions on whom to contact to report missing or damaged parts.

HYDRAULICS: There are many variations of auxiliary hydraulic connections on tractors. Read your tractor manual or check with your local dealer to determine how to properly connect the log splitter to your tractor's auxiliary hydraulics.

HYDRAULIC CONNECTION HOSE NOT INCLUDED: You need to provide your own supply and return hoses for connecting the log splitter to your tractor's auxiliary hydraulic connections. See p. 10 for instructions on determining the type and length of hoses you will need.

DETERMINE TRACTOR RPM THAT WILL PRODUCE THE PROPER HYDRAULIC FLOW RATE: Your tractor's engine speed will determine the flow rate, and it is unsafe to operate the log splitter at a flow rate higher than 11 GPM. You should read your tractor manual in advance to know how to keep the flow rate at or below 11 GPM before you operate the log splitter.

Any Questions, Comments, Problems or Parts Orders

Call Powerhorse Product Support 1-866-443-2576

Hazard Signal Word Definitions





	<p>This is the safety alert symbol. It is used to alert you to potential personal injury hazards. Obey all safety messages that follow this symbol to avoid possible injury or death.</p>
	<p>DANGER (red) indicates an imminently hazardous situation which, if not avoided, will result in death or serious injury.</p>
	<p>WARNING (orange) indicates a potentially hazardous situation which, if not avoided, could result in death or serious injury.</p>
	<p>CAUTION (yellow) indicates a potentially hazardous situation which, if not avoided, may result in minor or moderate injury.</p>
	<p>CAUTION (yellow) used without the safety alert symbol indicates a potentially hazardous situation which, if not avoided, may result in property damage.</p>

fig01453

Table of Contents

Hazard Signal Word Definitions	2
Table of Contents	3
About Your Log Splitter.....	4
Safety Label Locations	5
Machine Component Identification.....	7
Initial Set-up	8
Connecting to Tractor & Transporting to Job Site	9
Before Each Use – Work Site Selection and Set Up.....	14
Splitting Operation	16
Storage.....	22
Periodic Maintenance	23
Troubleshooting.....	24
Specifications	25
Parts Breakdown – Exploded View 11965 – Rev B.6	26
Summary of Important Safety Information for Operation	28
Assembly Instructions	33
Limited Warranty	53
California proposition 65 information.....	54

About Your Log Splitter

Thank you for purchasing your Powerhorse log splitter!

About Your Log Splitter:

This log splitter is a machine designed to split wood logs using a hydraulically powered moving wedge. The log splitter is connected to and powered by your tractor's hydraulic system.

This log splitter is designed to split logs *lengthwise with the grain only*.

This log splitter model is capable of splitting logs up to 25" long and 14" in diameter.

Your splitter can be used in either a vertical or horizontal splitting position:

- When the splitter is set up to operate in the horizontal splitting position, a log is placed on the horizontal beam and the wedge moves horizontally into the end of the log to split it.
- When the splitter is set up to operate in the vertical splitting position, the log is placed on the endplate, upright on its end, and the wedge moves down into the top of the log to split it.

The horizontal splitting position is used for lighter logs that can be easily loaded onto the beam. The vertical splitting position is used for heavier logs that are difficult to load onto the beam.

The technical specifications for your log splitter are provided in the Specifications section of this manual.

WARNING

This log splitter uses a high-pressure hydraulic system to generate a very strong splitting force.

Read the manual completely before using the machine to understand how to safely operate and maintain it.

Follow all safety precautions presented throughout this manual. A summary of important safety information can be found at the end of this manual.

Contact Powerhorse Product Support at 1-866-443-2576 for any questions about the appropriate use of this log splitter and/or optional accessories.

Warranty Registration:

Please fill in the warranty registration information in the back of this manual and have it on hand when you call in on a warranty claim or replacement parts.

Attention: All Rental Companies and Private Owners who loan this equipment to others!

All persons to whom you rent/loan the log splitter must have access to and read this manual. Keep this owner's manual with the splitter at all times and advise all persons who will operate the machine to read it. You must provide instruction on how to safely operate the splitter and remain available to answer any questions a renter/borrower might have.

Safety Label Locations

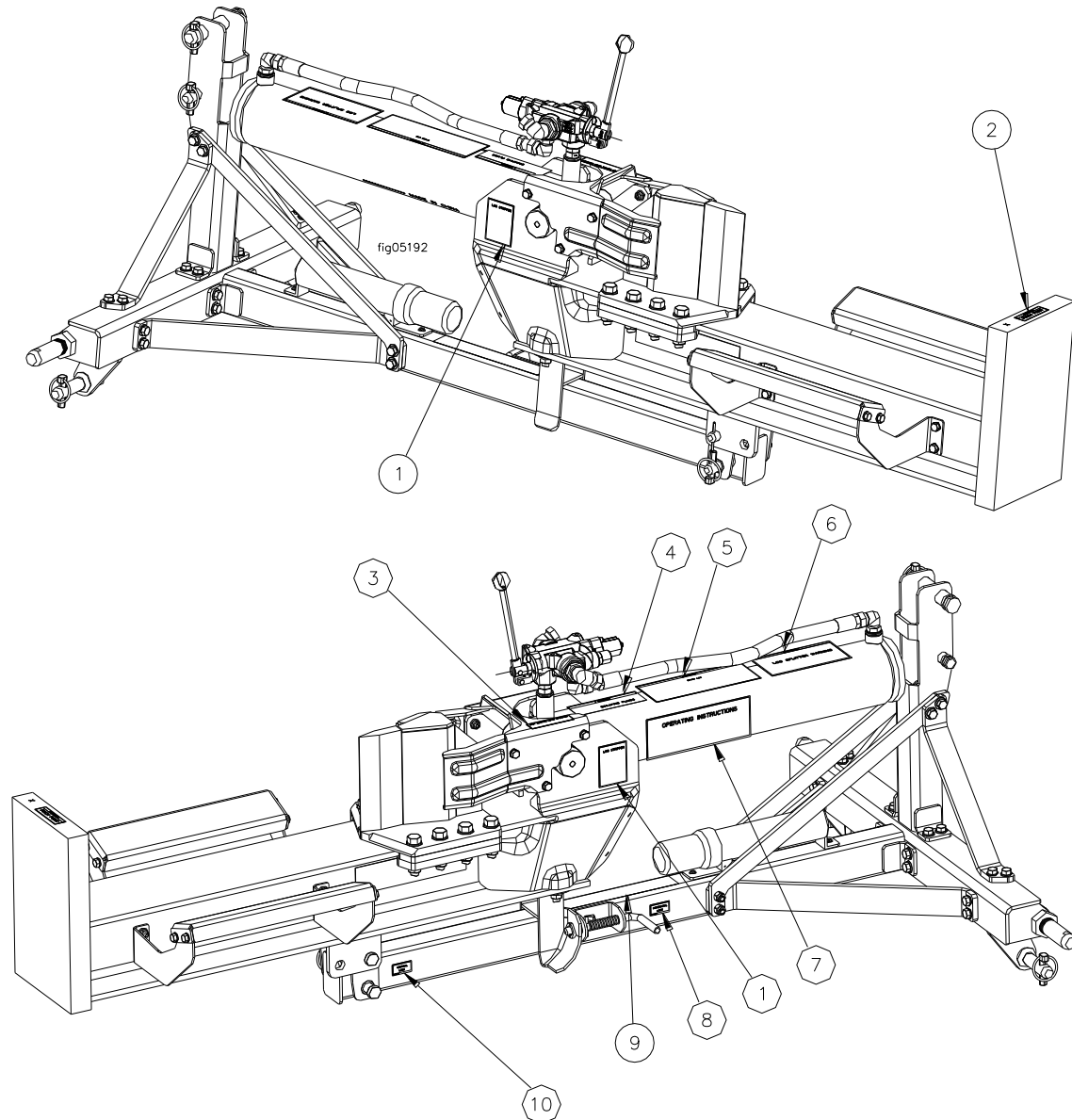

Reference #	Part Number	Description	Qty
1	778717	Decal, Log Stripper	2
2	787944	Decal, Pinch Point	1
3	778609	Decal, Split Control	1
4	777891	Decal, Escaping Fluid	1
5	777889	Decal, Stuck Log	1
6	778610	Decal, Log Splitter Warning	1
7	777887	Decal, Operation Instructions	1
8	778597	Decal, Horizontal Lock	1
9	791352	Decal, Connecting/Driving	1
10	778714	Decal, Vertical Lock	1

Always make sure safety labels are in good condition. If a safety label is missing or not legible, order new labels or unsafe operation could result. Contact Powerhorse Product Support at 1-866-443-2576.

Safety Label Locations

1

**LOG STRIPPER
RETRACT WEDGE
TO REMOVE
STUCK WOOD**

WARNING

PINCH POINT
Keep hands clear
of wedge and
log stripper

787917

2

WARNING

PINCH POINT
Keep hands clear
during operation.

787944

3

SPLIT CONTROL LEVER OPERATION

Split Log Neutral Return

4

WARNING

ESCAPING HIGH PRESSURE HYDRAULIC FLUID HAZARD
High fluid pressures and temperatures are developed in the hydraulic system. Hydraulic fluid escaping through even a pin-hole opening can puncture skin and cause blood poisoning.

- Inspect hydraulic system regularly for leaks
- Never check for leaks with your hand while system is pressurized.
- Seek medical attention immediately if injured by escaping fluid.

5

WARNING

Moving parts can crush and cut. Pieces can fly out while splitting. Follow safety rules for operating the log splitter or serious injury could result.

- READ the Owner's Manual completely before operating.
- Only one person should operate the log splitter. If an assistant is helping to load logs, the operator should not actuate controls until the assistant is at least 10 ft away.
- Stay in the designated OPERATOR POSITION while actuating the controls.
- Split wood in direction of the grain only.
- Hold bark side of logs when loading.
- Keep hands away from wedge, endplate/ram, and partly split logs.
- Never leave log splitter unattended during operation.
- Stay off slopes and slippery surfaces.

See additional safety rules in the Owner's Manual.

PN 77689

6

WARNING

IF LOG BECOMES STUCK ON WEDGE
A log can become stuck to the wedge if the wedge becomes embedded in the log and the log doesn't split and separate. This can happen if the log is too stringy or tough to split completely. A stuck log will move back with the wedge on the initial attempt to retract the wedge. If this happens, STOP retracting the wedge immediately and follow the directions below.

NEVER attempt to remove a stuck log by:

- Using the hydraulic force of the splitter
- Modifying the splitter
- Adding attachments to the splitter.

Personal injury could result from log or metal pieces flying out at high speed toward the operator or bystanders, or the splitter could become damaged.

ALWAYS remove the log **MANUALLY** using the following procedure:

1. If there is already 1" or more of clearance between the log and endplate, go to step 2. Otherwise, retract wedge just enough to remove pressure between the log and endplate - about 1" clearance.
2. Turn engine/motor OFF.
3. Remove stuck log from the wedge manually with a pry bar or sledgehammer.
4. Do not attempt to resplit a stuck log once it has been removed from the wedge.

Important: Be extremely careful as log pieces may fly off as they separate from the wedge. Wear safety goggles and make sure bystanders are clear.

PN77689

8

**HORIZONTAL
LOCK**

PN 778597

10

**VERTICAL
LOCK**

PN 778714

7

OPERATING INSTRUCTIONS

GENERAL

- Stay in the OPERATOR POSITION while actuating controls.
- Never actuate controls until the helper is 10ft away from log splitter, including any helpers assisting to load logs.
- Wear eye protection, hearing protection, snug fitting gloves, and safety shoes or heavy boots. No loose or dangling apparel.

SETTING UP

- Place log splitter on dry, level ground.
- Secure splitter for unintended movement.
- Place splitter in horizontal or vertical position.
- Start engine/motor.

SPLITTING LOG

- Position log on beam, against endplate.
- Move split control to extend wedge and split log.
- Release split control to stop wedge.
- Move split control to return wedge.
- Remove split wood from work area.

Operator Position - horizontal

Operator Position - vertical

PN 777095

9

CONNECTING TO TRACTOR/DRIVING WITH LOG SPLITTER ATTACHED

Connecting to Tractor:

- Engage tractor parking brake.
- Secure lower hitch studs to tractor's lower link with lynch pins.
- Secure upper hitch studs to tractor's upper link with lynch pin.
- Connect hydraulic hose from tractor supply port to connection marked "IN" on splitter control valve.
- Connect second hydraulic hose from tractor return port to connection marked "OUT" on splitter control valve.

Driving with Log Splitter Attached:

- Read tractor manual for instructions on driving with 3-point hitch mounted implement attached.
- Drive slowly and with extra caution, especially on rough or sloped terrain.
- If you will be driving at speeds slower than 25 MPH on public roads, it is recommended that you display a "Slow Moving Vehicle" (SMV) emblem. Between 25 and 40 MPH, a "Speed Identification Symbol" (SIS) is sometimes also required. SMV and SIS signs are generally available at farm equipment dealers.
- Check local, state and federal vehicle requirements before driving on public roads.
- Engage parking brake before operating log splitter.

PN 793352

Machine Component Identification

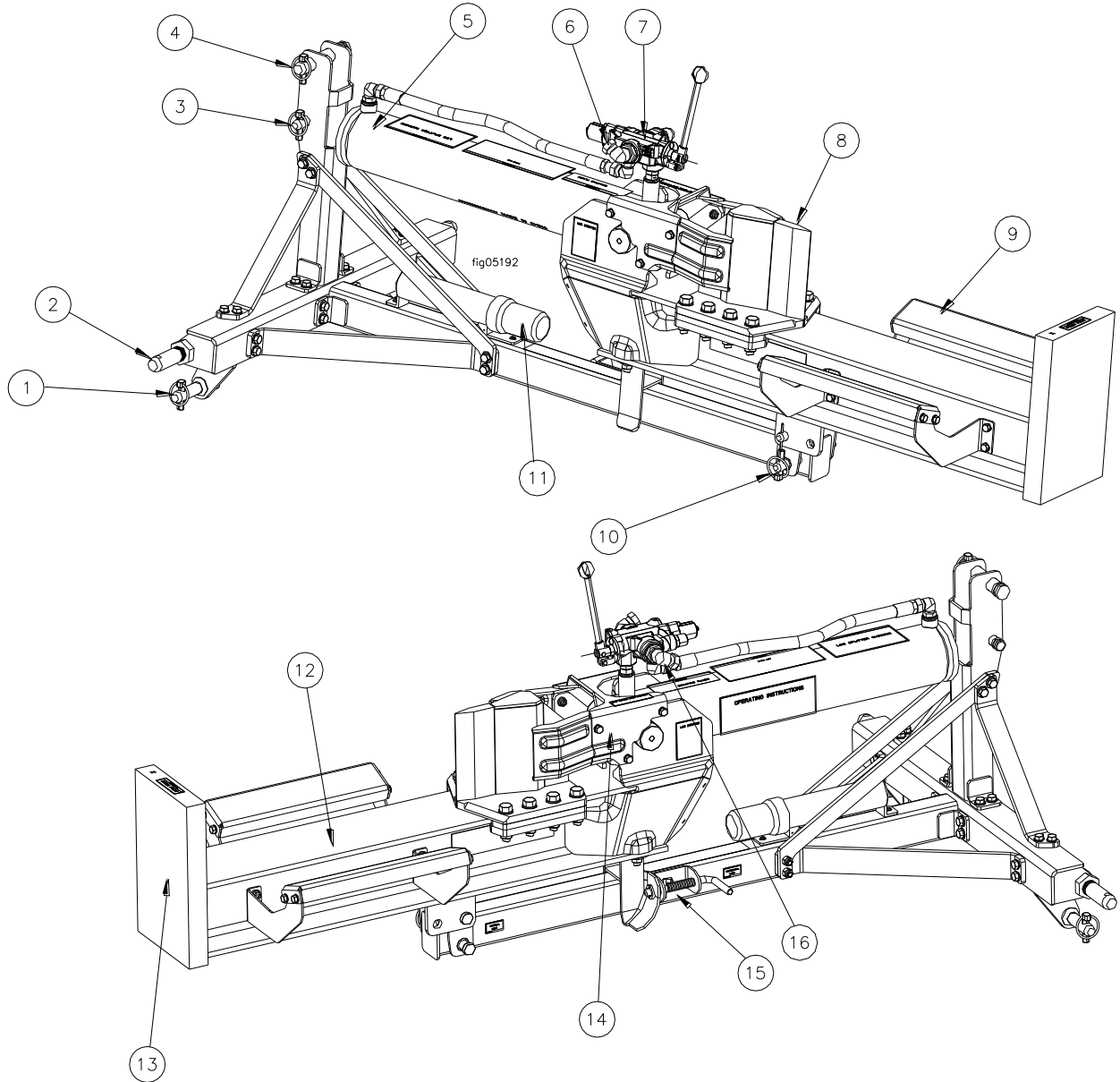

Ref	Description
1	Category 1 Lower Pin
2	Category 2 Lower Pin
3	Category 1 Upper Pin
4	Category 2 Upper Pin
5	Cylinder
6	Hydraulic Return Port
7	Valve
8	Wedge

Ref	Description
9	Log Cradle
10	Vertical Lock Pin
11	Manual Tube
12	Beam
13	Endplate
14	Stripper
15	Horizontal Lock
16	Hydraulic Supply Port

Initial Set-up

IMPORTANT!

Carefully read and follow all instruction for initial assembly and set-up of this log splitter. Failure to properly assembly and set up this equipment could result in serious injury to the user or bystanders, or cause equipment damage.

1. Inspect Log Splitter Components

Closely inspect all log splitter components.

(See Machine Components section of this manual for diagram of components.)

- If you have missing or damaged components, please contact Product Support at 1-866-443-2576.

2. Lubricate Beam

Apply grease to beam. This will help prevent wear between the wedge and beam.

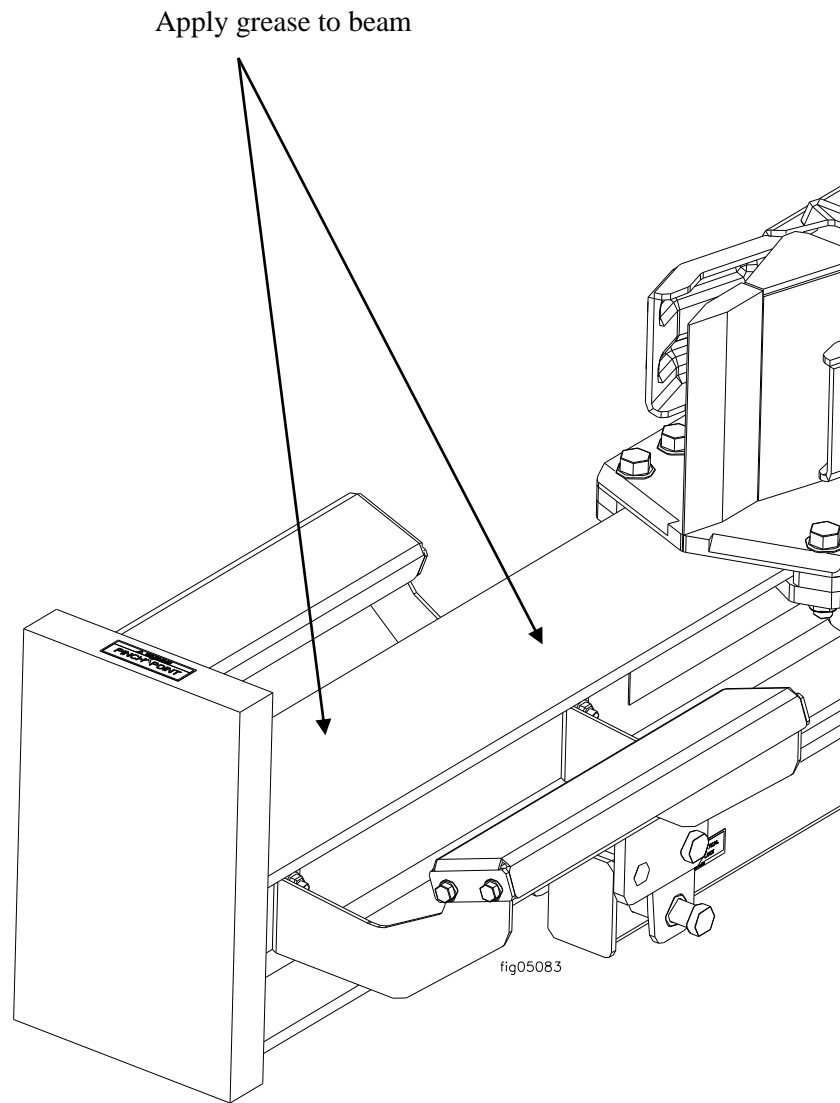

Connecting to Tractor & Transporting to Job Site



WARNING

The log splitter must be correctly mounted and then attached to the tractor hydraulic system for safe operation.

Follow the instructions below for safety mounting and connecting the log splitter.

1. Read instructions

Review your tractor manual or check with your dealer for instructions and safety information about how to properly connect the log splitter to your tractor's hydraulics. Since there are many variations of hydraulic connections on tractors, ensuring a correct hook-up to your tractor is your responsibility.

2. Tractor off & parking brake engaged

Turn off the tractor and engage the parking brake before attaching the log splitter.

3. Attach to tractor 3-point hitch links

Attach log splitter to tractor's 3-point hitch links.

- Connect the tractor's lower link to the lower hitch studs of the log splitter. Secure with lynch pins.
- Connect the tractor's upper link to the upper hitch pin of the log splitter. Secure with lynch pin.

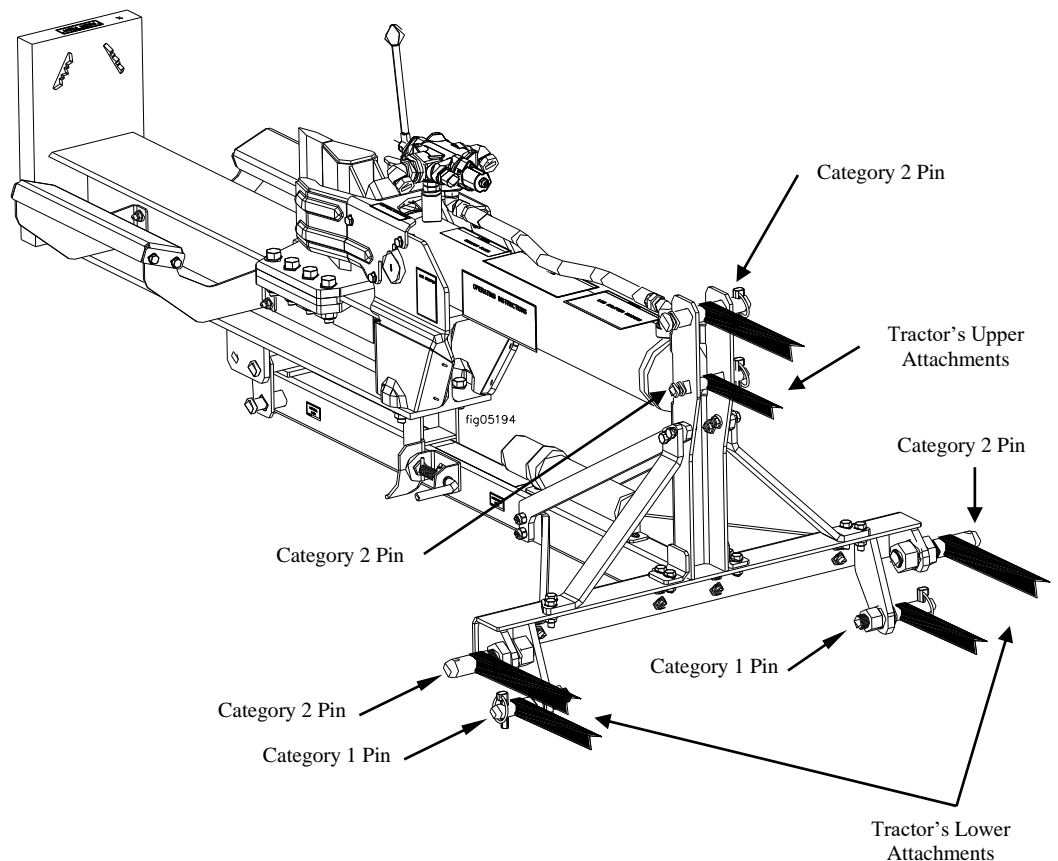

⚠️ WARNING: An improperly attached log splitter could become dislodged during transportation or operation, which could result in serious injury to the operator or bystanders. Do not drive the tractor or operate the log splitter until you are sure the log splitter is properly attached and hitch pins are fully engaged.

Connecting to Tractor & Transporting to Job Site

4. Measure & cut hydraulic hoses to correct length.

Measure & cut hydraulic hoses to the appropriate length for connecting log splitter to tractor hydraulics:

- You will need to supply two 1/2" hydraulic hoses rated for 3000 PSI with male, 1/2" NPT threaded ends.
- Measure the distance from your tractor's hydraulic supply port to the supply inlet port on the log splitter's control valve. Check distance with log splitter in both horizontal and vertical orientations, choose whichever distance is greater.
- Measure the distance from your tractor's hydraulic return port to the return outlet port on the log splitter's control valve. Check distance with log splitter in both horizontal and vertical orientations, choose whichever distance is greater.
- Cut two hydraulic hoses to an appropriate length for making these connections. Make sure there is sufficient, but not excessive length, such that hoses will not stretch, bind, kink, or dangle. Remember: this log splitter is both horizontal and vertical; make sure hoses are long enough for both splitting positions.

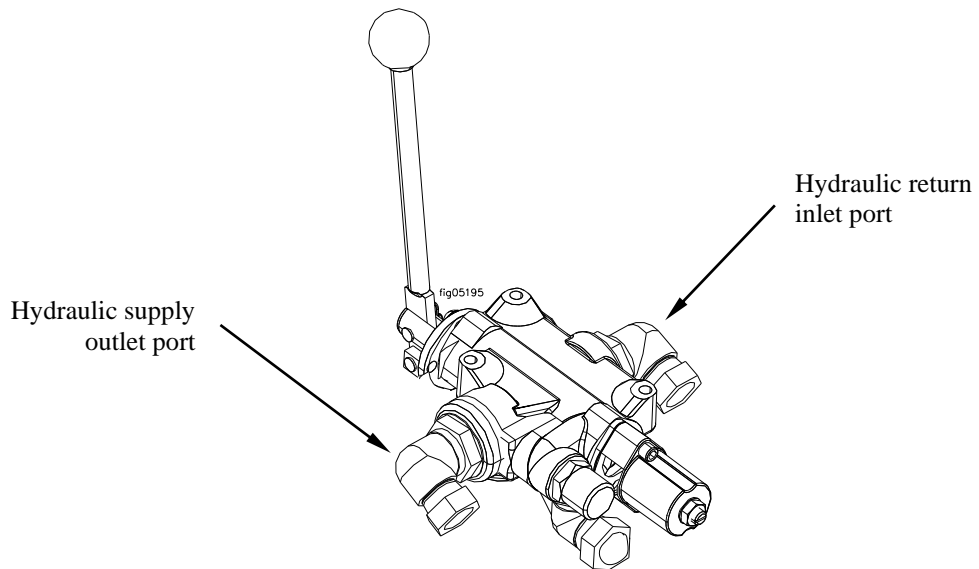

Connecting to Tractor & Transporting to Job Site

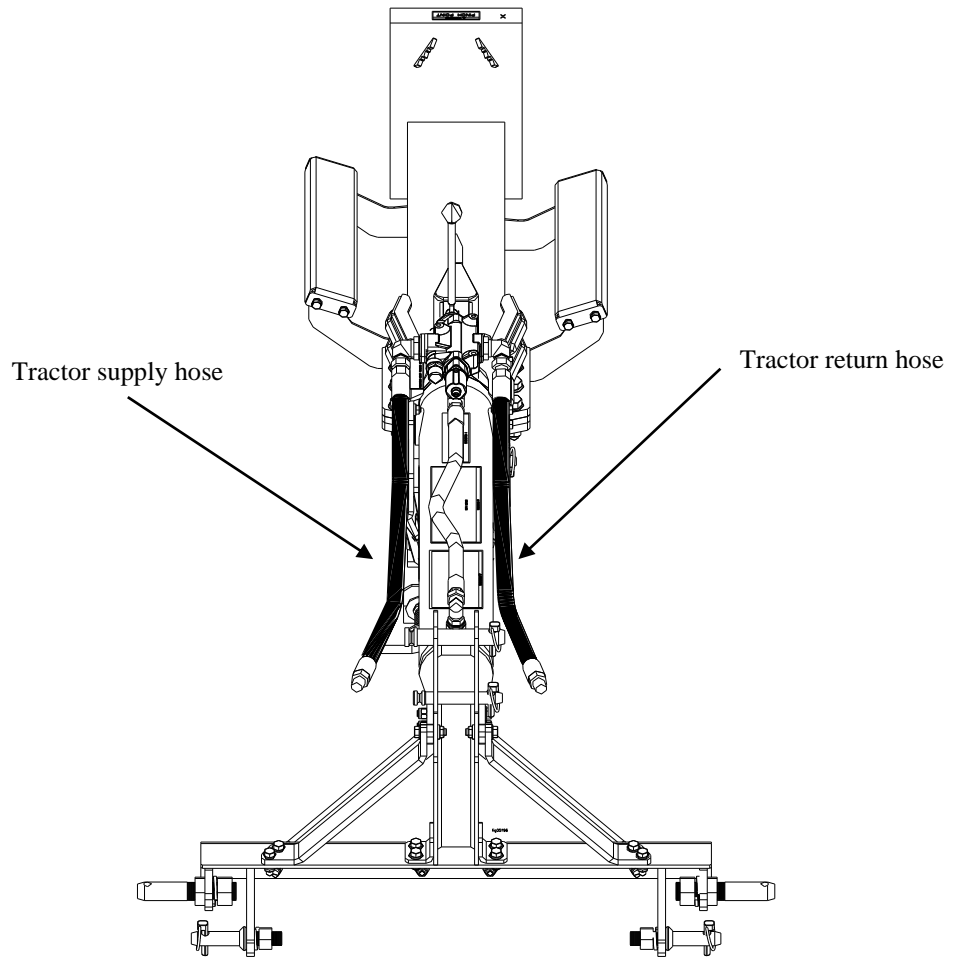

5. Connect hydraulic hoses

Connect the hydraulic hoses:

- Connect one hose from the tractor's hydraulic supply port to the supply inlet port on the log splitter's control valve.
- Connect the second hose from the tractor's return port to the connection at the return outlet port on the log splitter's control valve.
- Check to be sure that all fittings are tight.

⚠ WARNING: Make sure all fittings are tight before applying pressure. High fluid pressures and temperatures are developed in the hydraulic system. Hydraulic fluid escaping through even a tiny opening can burn or puncture skin, resulting in wounds that could cause blood poisoning, infections, disability, gangrene, amputation, or death. If injured by escaping fluid, no matter how small the wound is, see a doctor at once.

6. Add hydraulic oil to reservoir

- Start tractor and use split control lever to extend and retract wedge 5 (five) times to remove air from the high pressure lines.
- With wedge retracted, check tractor oil level again. Fill if necessary. Please refer to Specifications for appropriate oil type.

Connecting to Tractor & Transporting to Job Site

7. Hydraulic components

Check the hydraulic components carefully:

1. Visually inspect all hoses and clamps/fittings for cracks, fraying, kinks, or other damage.
2. Check all components for oily residue, which may indicate a leak.

Do NOT operate the log splitter if there is any indication of damage or oily residue. Small leaks in hydraulic lines can cause severe injuries and can also be an indication of catastrophic failure in the near future. The life of hydraulic hoses may be from a few months to a few years, depending on use and storage patterns.

▲WARNING: High fluid pressures and temperatures are developed in hydraulic log splitters. Hydraulic fluid escaping through a pin hole sized opening can burn or puncture skin, resulting in wounds that could cause blood poisoning, infection, disability, gangrene, amputation, or death. Therefore, the following instructions should be heeded at all times when inspecting or servicing the hydraulic components of the log splitter:

- Stop the tractor and move all split control levers back and forth to relieve pressure before changing or adjusting hydraulic system components such as hoses, tubing, fittings or other components.
- NEVER check for leaks with your hand. Leaks can be located by holding a piece of cardboard or wood (at least two feet long) with your hand at one end and passing the other end over the suspected area (wear eye protection). Look for discoloration of the cardboard or wood.
- NEVER adjust the pressure of the pump or valve.
- If injured by escaping fluid, no matter how small the wound is, see a doctor at once. A typical injection injury may be a small puncture wound that does not look serious. However, severe infection or reaction can result if proper medical treatment is not administered immediately by a doctor who is familiar with injection injuries.

8. Lubricate beam

Apply grease to beam. This will help prevent wear between the wedge and beam.

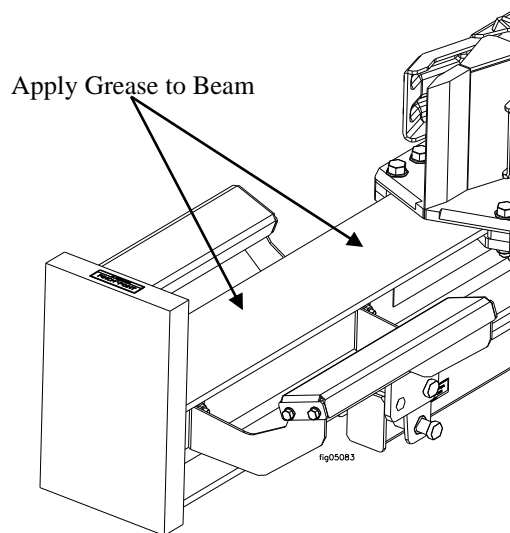

Connecting to Tractor & Transporting to Job Site

Towing:

1. Read instructions	Review towing safety instructions in your vehicle manual.
2. Drive to desired location	<p>Drive tractor and log splitter carefully to desired work site. (See instructions on pg.15 on selecting an appropriate work site)</p> <p><u>Important safety instructions:</u></p> <ul style="list-style-type: none"> • Read tractor instructions. Review safety instructions in your tractor manual with regard to driving with 3-point hitch mounted equipment attached. • Securely attached. Be sure splitter is securely attached before transporting. • Added length. Be aware of the added length of the splitter. • Reduced road stability. Be aware that heavy, 3-point hitch mounted equipment can reduce road stability, regardless of the amount of front-end counterweight added. Drivers should take extra caution when driving with the log splitter attached. Reduce your speed and take extra caution during turns or while driving on rough or sloped terrain. • No riding or cargo on splitter. Never ride or transport cargo on the log splitter. • On public roads. If transporting the log splitter on a public road, make sure to comply with all local, state, and federal requirements. • Unattended. Turn off the tractor before leaving the splitter unattended. • Under the influence. Never transport or operate this splitter while under the influence of alcohol, drugs, or medication.
3. Engage parking break	<p>Make sure the tractor’s parking brake is engaged before operating the log splitter.</p> <p> WARNING: If the parking brake is not engaged, the tractor could roll while you are operating the log splitter. Personal injury could result. Always engage the parking brake before leaving the tractor while the splitter is attached.</p>

Before Each Use – Work Site Selection and Set Up

Step One: Inspect and maintain log splitter before each use

If the log splitter has been used previously, it must be inspected and maintained BEFORE EACH SUBSEQUENT USE.

WARNING

ALWAYS shut off the tractor, disconnect hydraulic lines, and relieve system pressure before inspecting, cleaning, adjusting, or repairing the splitter. Relieve system pressure by moving Split Control Lever back and forth several times.

IMPORTANT:

If a part needs replacement, only use parts that meet the manufacturer’s specifications. Replacement parts that do not meet specifications may result in a safety hazard or poor operation of the log splitter.

1. Tractor off / relieve hydraulic pressure	<p>Perform all inspections/repairs with the tractor off and hydraulic pressure relieved.</p> <ol style="list-style-type: none"> 1. Turn off tractor engine. 2. Relieve all hydraulic system pressure by moving the split control lever and the tractor hydraulic control valve handles back and forth several times. 3. Disconnect the hydraulic lines.
2. Remove debris	<p>Remove debris from moving parts</p> <p>Debris on moving parts can cause excess wear. Clear debris from the slide beam, wedge, and endplate.</p>
3. Lubricate beam	<p>Apply grease to beam. This will help prevent wear between the wedge and beam.</p>
4. Mechanical parts	<p>Check to be sure that all nuts and bolts are tight to make sure the log splitter is in safe working condition.</p>
5. Hydraulic system	<p>Check the hydraulic system carefully:</p> <ol style="list-style-type: none"> 1. Visually inspect all hoses, tubing, clamps/fittings, and cylinder for cracks, fraying, kinks, or other damage. 2. Check all components for oily residue, which may indicate a leak. <p>Do NOT operate the log splitter if there is any indication of damage or oily residue. Small leaks in hydraulic lines can cause severe injuries and can also be an indication of catastrophic failure in the near future. The life of hydraulic hoses may be from a few months to a few years, depending on use and storage patterns.</p> <p> WARNING: High fluid pressures and temperatures are developed in hydraulic log splitters. Hydraulic fluid escaping through a pin hole sized opening can burn or puncture skin, resulting in wounds that could cause blood poisoning, infection, disability, gangrene, amputation, or death. Therefore, the following instructions should be heeded at all times when inspecting or servicing the hydraulic components of the log splitter:</p> <ul style="list-style-type: none"> • Move all control valve handles back and forth to relieve pressure before changing or adjusting hydraulic system components such as hoses, tubing, fittings or other components. • NEVER check for leaks with your hand. Leaks can be located by holding a piece of cardboard or wood (at least two feet long) with your hand at one end and passing the other end over the suspected area (wear eye protection). Look for discoloration of the cardboard or wood.

Before Each Use – Work Site Selection and Set Up



- NEVER adjust the pressure setting of the valve.
- If injured by escaping fluid, no matter how small the wound is, see a doctor at once. A typical injection injury may be a small puncture wound that does not look serious. However, severe infection or reaction can result if proper medical treatment is not administered immediately by a doctor who is familiar with injection injuries.

6. Shields / guards **Replace all guards and shields after servicing the log splitter.**

Step Two: Work site selection and log splitter set-up

WARNING

It is important to select an appropriate work site and properly set up the log splitter in order to minimize the risk of slips and falls, equipment rolling or tipping over, carbon monoxide poisoning, and accidental fires.

1. Select location	<p>Select an appropriate location for operating the log splitter.</p> <p><u>Requirements:</u></p> <ol style="list-style-type: none"> 1. Dry-level surface with good footing. Stay clear of areas with mud, ice, tall grass, weeds, brush, or snow. 2. Outdoors and far away from windows, doors and air intakes. <p style="text-align: center;"> WARNING: The running tractor engine gives off carbon monoxide, a poisonous gas that can kill you. You CANNOT smell it, see it, or taste it.</p> <ul style="list-style-type: none"> • ONLY run log splitter <u>OUTDOORS</u> and away from air intakes. NEVER run log splitter inside homes, garages, sheds, or other buildings or semi-enclosed spaces. These spaces can trap poisonous gases, EVEN if you run a fan or open windows. • If you start to feel sick, dizzy, or weak while using the log splitter, shut off the engine and get to fresh air RIGHT AWAY. See a doctor. You may have carbon monoxide poisoning.
2. Fire precautions	<p>Take the following precautions against fire:</p> <p>Keep a fire extinguisher available (classified for both ordinary combustibles & flammable liquids) as a precautionary measure when operating the log splitter in dry areas.</p>
3. Position splitter 7' from any combustibles or flammable liquids	<p>Position tractor exhaust and other hot elements of the tractor engine at least 7 ft. from combustible objects during operation.</p> <p>Hot exhaust fumes from tractor could cause fire. Also, hydraulic oil leaking or spraying on hot engine can ignite.</p>
4. Engage parking brake	<p>Make sure the tractor's parking brake is engaged before operating the log splitter.</p> <p style="text-align: center;"> WARNING: If the parking brake is not engaged, the tractor could roll while you are operating the log splitter. Personal injury could result.</p>
5. Apply grease	<p>Apply grease to the beam.</p>

Splitting Operation

WARNING

Before starting this log splitter, review the following instructions and safety information for safe operation of the log splitter.

Failure to follow these rules may result in serious injury to the operator or bystanders from moving parts that crush, cut, or entangle from flying objects, burns, fire, falling or tripping, or from carbon monoxide poisoning.

General safety information:

- **Read manual.** Do not allow anyone to operate the log splitter who has not read the Owner's Manual or has not been instructed on the safe use of the splitter. The log splitter owner should instruct all operators in safe log splitter operation.
- **Age restrictions.** Never allow anyone under 16 years old to operate the log splitter. Anyone 16 years and older must be trained and supervised by a trained adult.
- **Intended use.** Log splitters should only be used for splitting wood logs, lengthwise with the grain. Do not use for other purposes as unforeseen hazards may result.
- **Modifications.** Never modify or alter the log splitter in any way. Modifications can create serious safety hazards and will void the warranty:
- **Attachments.** Never add attachments to the splitter, except for authorized accessories supplied by the manufacturer with instructions for safe installation and use.
- **Remote control.** NEVER attach a rope, cable, or other remote device to the splitting control.
- **Splitting wedge.** NEVER attempt to change the height or speed of the splitting wedge.
- **Pressure setting.** NEVER increase the pressure setting of the pump or control valve.
- **Safety equipment / controls.** Always operate the log splitter with all safety equipment in place and in good working order, and all controls properly adjusted for safe operation.
- **Know how to stop.** Be thoroughly familiar with all controls and with the proper use of the equipment. Know how to stop the log splitter and relieve system pressures quickly if needed.
- **Operating speed.** Always operate the log splitter at the manufacturer's recommended speed. Adjust the tractor speed so the flow rate does not exceed 11 GPM. Make sure to see the tractor specification for determining relationship between flow rate and engine speed since a higher flow rate makes the wedge move dangerously fast.
- **Daylight only.** Only use the log splitter in daylight so you can see what you are doing.
- **Smoking / sparks.** Never smoke while operating the log splitter, and never operate near sources of sparks or flames.
- **Under the influence.** Never operate, or let anyone else operate, the log splitter while under the influence of alcohol, drugs, or medication.
- **Unattended.** Never leave the machine unattended while the engine is running.
- **Adjusting / repairing.** Always make sure the engine is off before cleaning, repairing or adjusting the splitter, except as recommended by the manufacturer. In addition, move all control handles back and forth to relieve system pressure *before changing or adjusting hydraulic system components* such as hoses, tubing, fittings or other components.
- **Replace labels.** Always make sure safety labels are in place and in good condition. If a safety label is missing or not legible, order new labels because unsafe operation can result. Call 1-866-443-2576 to order new safety labels.

Splitting Operation

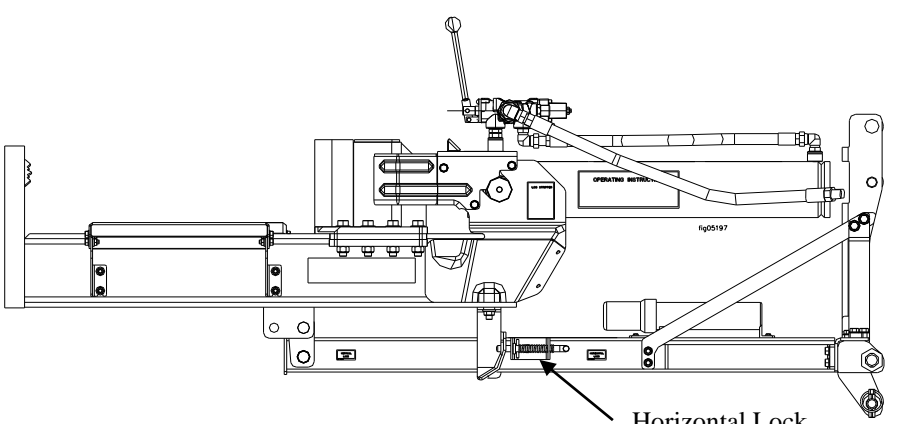
<p>1. Put on protective clothing / gear</p>	<p>Wear the following protective clothing and safety gear:</p> <ol style="list-style-type: none"> 1. Eye protection. Always wear safety glasses or goggles when operating the machine. Pieces of log may fly out and serious eye injury can occur. 2. Boots. Falling logs can crush feet. Always wear safety shoes or heavy boots when operating or helping to load logs. 3. Gloves. Wear snug fitting gloves without drawstrings or loose cuffs. 4. Hearing protection. The use of earplugs or other hearing protection device is recommended. 5. No Loose / dangling. Loose or dangling apparel can become entangled in moving parts. Never wear jewelry or loose-fitting clothing.
<p>2. Engage parking brake</p>	<p>Secure log splitter from unintended movement—make sure the tractor’s parking brake is engaged before operating the log splitter.</p> <p>⚠️WARNING: If the parking brake is not engaged, the tractor could roll while you are operating the log splitter. Personal injury could result.</p>
<p>3. Set to horizontal or vertical</p> <p>a) Set to Horizontal position</p>	<p>Set log splitter into either the horizontal or vertical splitting position.</p> <p><i>The <u>HORIZONTAL</u> splitting position is used for lighter logs that can be easily loaded onto the beam. The <u>VERTICAL</u> splitting position is used for light logs as well as heavy logs that are difficult to load onto the beam.</i></p> <p>⚠️CAUTION: Musculoskeletal injury can result from lifting logs onto the log splitter if proper lifting techniques are not used or the logs are too heavy for a person’s size, weight, or strength. In some cases, logs as small as 8” in diameter and 14” in length may be heavier than what some persons should be repeatedly lifting onto the splitter. The use of the vertical splitting position can greatly reduce the need to lift logs onto the splitter. Employers are advised to consider NIOSH lifting guidelines when assigning employees to log splitting tasks for an extended period of time.</p> <p>Horizontal Splitting Position.</p> <p>Make sure beam is locked securely in the horizontal position by checking the horizontal lock.</p> 

Splitting Operation

b) Set to Vertical position

Vertical Splitting Position

Pull out horizontal lock latch rod, grasp and lift beam until it rotates into vertical position.

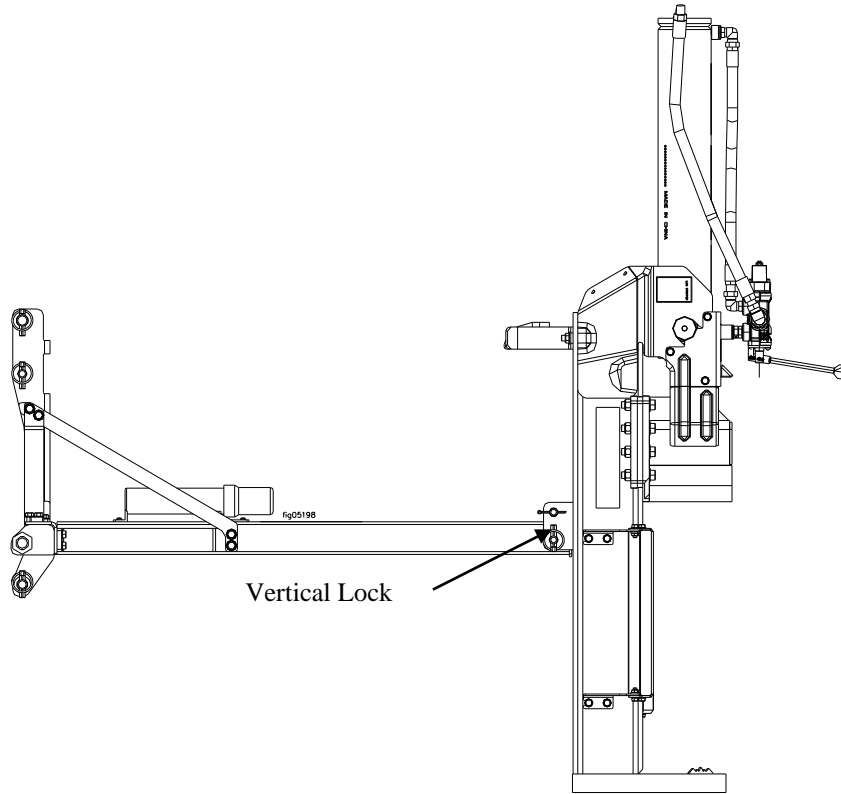

⚠ WARNING: Crush hazard. The beam is heavy – do not let it just drop. It could crush fingers or cause damage to the splitter.

1. Remove lynch pin and vertical lock pin and pivot beam to vertical position.
2. Lock in vertical position using vertical lock pin and lynch pin through the vertical lock.
3. To return to horizontal position, remove lynch pin and pull out vertical lock pin, grasp and lower beam carefully in a controlled manner until it rests on the tow bar, lock beam in the horizontal position with latch rod. Insert vertical lock pin into vertical lock on tow bar, secure with lynch pin.

Splitting Operation

4. Load log

Load log onto beam with a cut end against the endplate – positioned for a lengthwise cut.

Notes:

- The log splitter is designed only for cutting lengthwise with the grain, NOT for cutting across the grain.
- This log splitter is designed for cutting logs only up to a maximum of 14” in diameter and 25” long. Larger diameter logs could get stuck on the wedge and longer logs will not fit on the beam.

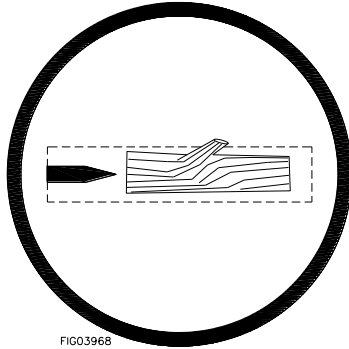

Correct Log Orientation

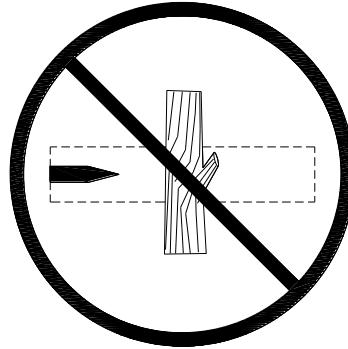

Incorrect Log Orientation

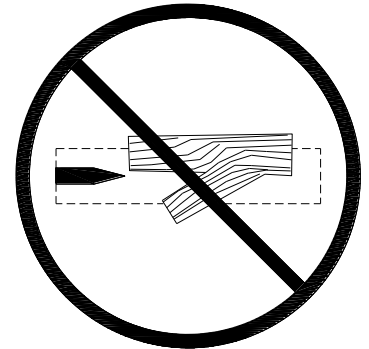

⚠ WARNING: ALWAYS keep hands and feet away from the endplate, wedge, and partially split logs while loading, operating and unloading the log splitter.

Important safety instructions:

- **Hold bark side.** Hold the bark side of logs when loading or positioning, never the ends. Never place your hands or any part of your body between a log and any part of the log splitter.

NOTE for vertical position loading: Place the log on the endplate and turn it until it leans against the beam and is stable. If the log is too big or oddly shaped, stabilize the log with wooden shims between the log and endplate or ground. **DO NOT** use your leg or knee to stabilize the log. **NEVER** stabilize the log by placing your hand on top of the log.

- **Wedge moving.** NEVER load or unload logs while the wedge is moving.
- **Straddling / reaching across.** Never straddle, reach across, or step over the beam while the engine is running and the log splitter is in the horizontal position. You could trip, actuate the controls, and get seriously injured.
- **Unsplit log pile.** Do not pile logs to be split in a place that will make you reach across the log splitter in order to load them.
- **Square log ends.** Logs that are not cut square can slide out while splitting and become a safety hazard or cause excessive force to log splitter components. Use a chainsaw to cut logs square on each end before attempting to split them.
- **Single log.** Never attempt to split more than one log at a time. Pieces of log can unexpectedly be thrown from the machine causing serious injury.
- **Split along grain.** Do not use the log splitter to split logs across the grain. Doing so will damage the log splitter and could also cause pieces of log to be thrown, injuring the operator or bystanders.

Splitting Operation

5. Extend wedge

Move Split Control Lever toward endplate to extend wedge and split log.

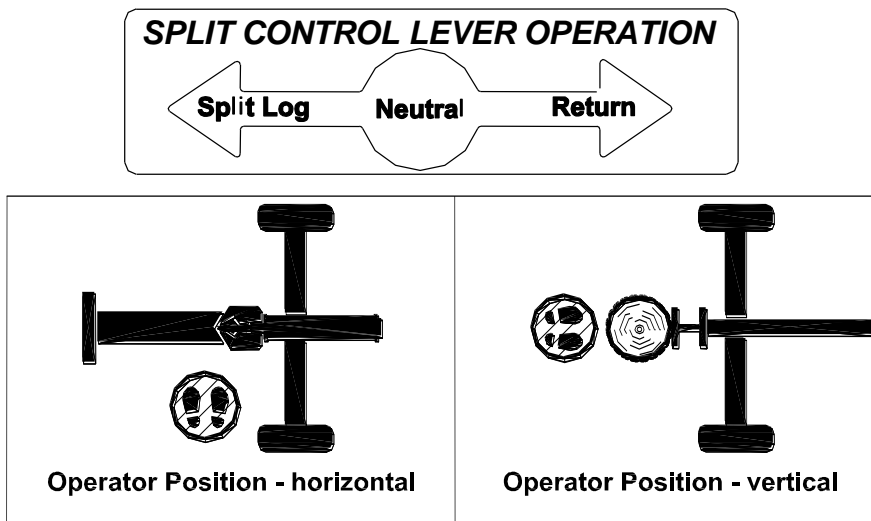

Important safety instructions:

- **Operator position.** ALWAYS operate the log splitter from the manufacturer’s indicated OPERATOR POSITION. (See diagram above.) Other positions are unsafe because they can increase the risk of injury from crushing, cutting, flying objects, or burns.
- **Remove hands.** Remove both hands from log before activating Split Control Lever.
- **Hand activate.** Use only your hand to operate the Split Control Lever. Never use any other body part, or a rope, cable, or other remote device to actuate the control.
- **Second person.** Many accidents occur when there is more than one person involved in loading and operating the log splitter. Only one person should operate the controls. *If a second person is assisting in loading logs, the operator must NEVER actuate the Split Control Lever until the assistant and all bystanders are at least 10 feet away. NEVER allow an assistant to hold the log in place while the operator actuates the Split Control Lever.*

6. Stop wedge

Release Split Control Lever to stop wedge movement when log is split.

⚠WARNING: Cracks in logs can close quickly and pinch fingers. Keep fingers away from any cracks that open in partially split logs.

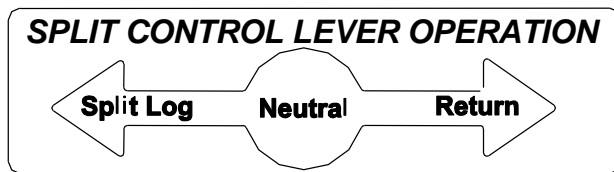

7. Important STUCK LOG procedure

If a log does not split completely and becomes stuck on the wedge, follow the instructions below to remove the log. A log can become stuck to the wedge if the wedge becomes embedded in the log and the log doesn’t split and separate. This can happen if the log is too stringy or tough to split completely. A stuck log will move back with the wedge on the initial attempt to retract the wedge. If this happens, retract the wedge completely to allow the splitter to strip the log from the wedge. Keep hands clear of log and wedge while wedge is retracting.

Splitting Operation

⚠ WARNING: NEVER attempt to remove a stuck log by:

- Modifying the splitter.
- Adding attachments to the splitter.

Personal injury could result from log or metal pieces flying out at high speed toward the operator or bystanders, or the splitter could become damaged.

8. Return wedge

Move Split Control Lever away from end plate to return wedge.

Once the control valve is actuated in the return direction, the wedge is designed to keep returning by itself completely and then stop automatically.

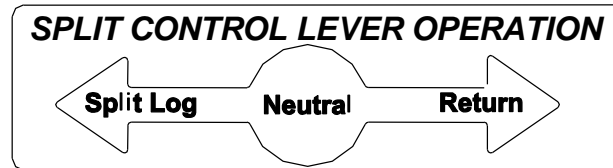

⚠ WARNING: Stay clear while the wedge is returning. It is still powerful enough on the return stroke to cause serious injury.

9. Remove split wood

Remove split wood from area.

Move each log away from log splitter after it is split. Split logs left near the log splitter are a trip hazard.

10. After use

Return to horizontal position.

If in the vertical position, return log splitter to the horizontal position for greater stability and to prepare for transportation.

Storage

Follow the instructions below for storing your log splitter between uses.

1. Retract wedge	Retract the wedge completely to keep the rod protected from corrosion.
2. Wipe with oily rag	Wipe the beam and wedge with an oily rag to prevent corrosion.
3. Splitter storage location	Store the log splitter in a location away from corrosive material. <u>NOTE:</u> Do not store the log splitter near fertilizer or any other corrosive material.

Periodic Maintenance

In addition to the maintenance performed with each use, periodic maintenance should also be performed according to the following schedule.

WARNING

ALWAYS shut off the tractor engine and relieve system pressure before cleaning, adjusting, or repairing the splitter. Relieve system pressure by moving Split Control Lever back and forth several times.

IMPORTANT:

If a part needs replacement only use parts that meet the manufacturer's specifications. Replacement parts that do not meet specifications may result in a safety hazard or poor operation of the log splitter.

Hydraulic Components

 **WARNING:** High fluid pressures and temperatures are developed in hydraulic log splitters. Hydraulic fluid escaping through a pin hole sized opening can burn or puncture skin, resulting in wounds that could cause blood poisoning, infection, disability, gangrene, amputation, or death. Therefore, the following instructions should be heeded at all times when inspecting or servicing the hydraulic components of the log splitter.

- NEVER check for leaks with your hand. Leaks can be located by holding a piece of cardboard or wood (at least two feet long) with your hand at one end and passing the other end over the suspected area (wear eye protection). Look for discoloration of the cardboard or wood.
- NEVER adjust the pressure of the pump or valve.

If injured by escaping fluid, no matter how small the wound is, see a doctor at once. A typical injection injury may be a small wound that does not look serious. However, severe infection or reaction can result if proper medical treatment is not administered immediately by a doctor who is familiar with injection injuries.

1. **Refer to your tractor's manual for proper hydraulic component maintenance.**
2. **Use only hydraulic oil approved by tractor manufacturer.**
3. **After following your tractor's manual for proper hydraulic component maintenance, check hydraulic oil reservoir level.**
4. **Start tractor and use split control lever to extend and retract wedge 5 (five) times to remove air from the high pressure lines.**
5. **With wedge retracted, check oil level again. If necessary, fill according to tractor manufacturer's specifications.**

Troubleshooting

WARNING

Before troubleshooting or attempting to service, read the following safety instructions to avoid serious injury to the operator or bystanders from moving parts that can crush or cut, burns, fire or explosion, or escaping high pressure hydraulic fluid.

Important Safety Instructions:

1. **Tractor off.** Always make sure the tractor engine is off before cleaning, repairing or adjusting the splitter, except as recommended by the manufacturer.
2. **Hydraulic safety.** High fluid pressures and temperatures are developed in hydraulic log splitters. Hydraulic fluid escaping through a pin hole sized opening can burn or puncture skin, resulting in wounds that could cause blood poisoning, infection, disability, gangrene, amputation, or death. Therefore, the following instructions should be heeded at all times when inspecting or servicing the hydraulic components of the log splitter:
 - Turn off tractor engine, move all split control levers back and forth to relieve pressure, and disconnect hydraulic lines before changing or adjusting hydraulic system components such as hoses, tubing, fittings or other components.
 - NEVER check for leaks with your hand. Leaks can be located by holding a piece of cardboard or wood (at least two feet long) with your hand at one end and passing the other end over the suspected area (wear eye protection). Look for discoloration of the cardboard or wood.
 - If injured by escaping fluid, no matter how small the wound is, see a doctor at once. A typical injection injury may be a small puncture wound that does not look serious. However, severe infection or reaction can result if proper medical treatment is not administered immediately by a doctor who is familiar with injection injuries.

Problem	
Wedge will not move	Solution: A,D,E,H,J
Slow wedge speed when extending or retracting	Solution: A,B,C,H,I,K
Wood will not split or splits extremely slow	Solution: A,B,C,F,I,K
Tractor engine bogs down during splitting	Solution: G
Tractor engine stalls under low load condition	Solution: D,E
Cause	Solution
A- Insufficient oil to pump	Check oil level in reservoir
B- Air in oil	Check oil level in reservoir, check for leaks in the suction line
C- Excessive pump inlet vacuum	Check pump inlet hose for blockage or kinks
D- Blocked hydraulic lines	Flush and clean the splitter hydraulic system
E- Blocked control valve	Flush and clean the splitter hydraulic system
F- Low control valve setting	Adjust control valve with a pressure gauge
G- High control valve setting	Adjust control valve with a pressure gauge
H- Damaged control valve	Return control valve for authorized repair
I- Internal control valve leak	Return control valve for authorized repair
J- Damaged cylinder piston	Return cylinder for authorized repair
K- Internally damaged cylinder	Return cylinder for authorized repair

Any Questions, Comments, Problems or Parts Orders
Call Powerhorse Product Support 1-866-443-2576

Specifications

Item #	11965
Tonnage.....	22 TON
Max Pressure.....	3000 PSI
Max Flow.....	11 GPM
Hydraulic Cylinder Bore....	4”
Hydraulic Cylinder Stroke ..	24 in
Maximum Log Diameter....	14”
Maximum Log Length	25”
Hydraulic Fluid Type.....	Depends on Tractor
Hydraulic Oil Capacity.....	Depends on Tractor
Control Valve Type.....	Open Center
Overall Dimensions	40”L x 31”W x 25”H
Dry Weight.....	340 lb

The manufacturer reserves the right to make improvements in design and/or changes in specifications at any time without incurring any obligation to install them on units previously sold.

Any Questions, Comments, Problems or Parts Orders
Call Powerhorse Product Support 1-866-443-2576

Parts Breakdown – Exploded View 11965 – Rev B.6

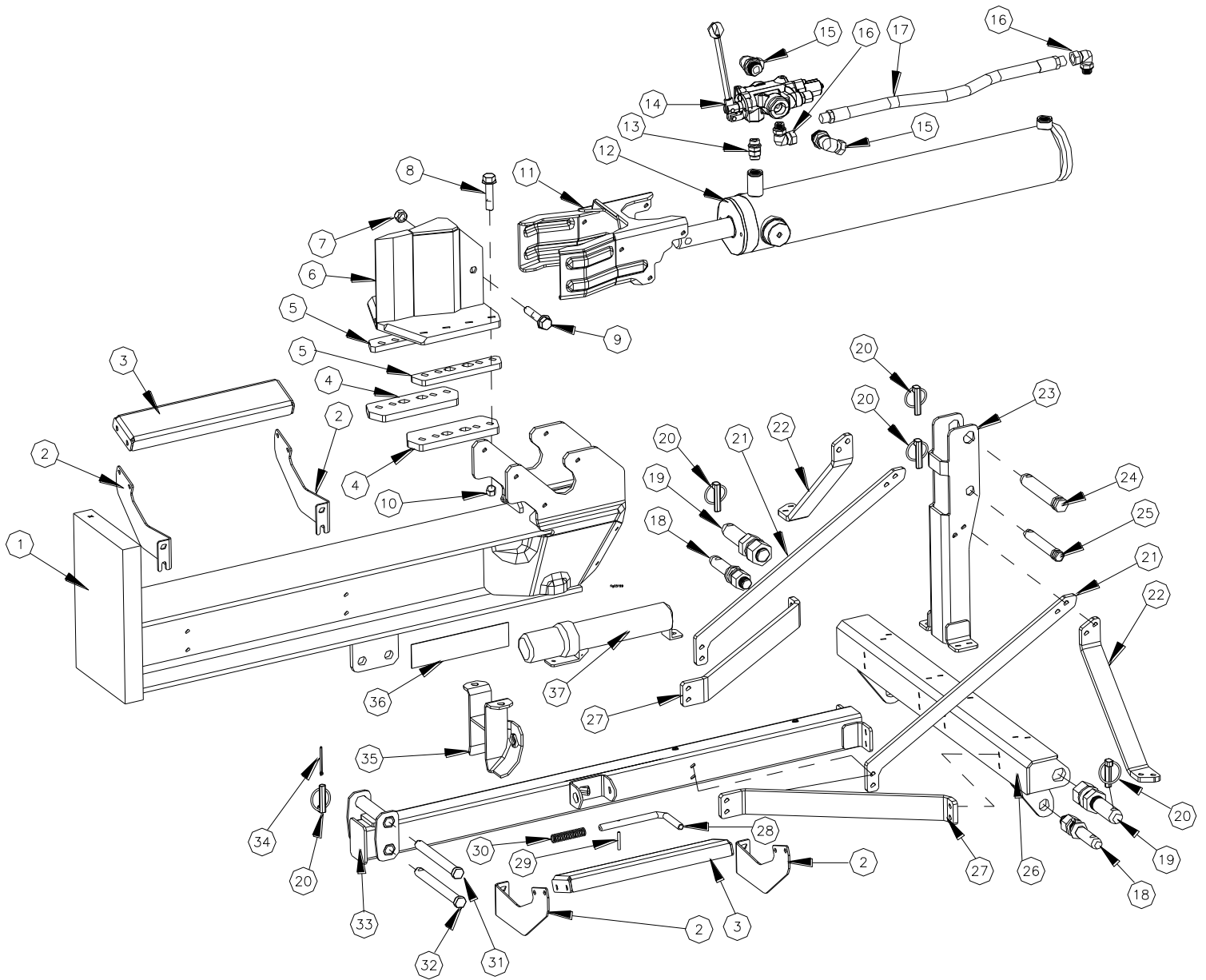

Parts Breakdown – Exploded View 11965 – Rev B.6

Item	Part No.	Description	Qty.
1	790510	Beam	1
2	790533	Log Cradle Mount	4
3	790540	Log Cradle Face Plate	2
4	790359	Keeper	2
5	790861	Spacer	2
6	790514	Wedge	1
7	82570	Wedge Nut	1
8	82525	Keeper Bolt	8
9	82554	Wedge Bolt	1
10	82570	Keeper Nut	8
11	790560	Log Stripper	1
12	790420	Cylinder 4" x 24"	1
13	790488	Valve Fitting	1
14	791867	Control Valve	1
15	778831	Large Swivel Fitting	2
16	778827	Small Swivel Fitting	2
17	778619	Cylinder Extension Hose	1
18	791136	Category 1 Lift Arm Pin	2
19	791137	Category 2 Lift Arm Pin	2
20	39159	Lynch Pin	5
21	791118	Vertical Bracket	2
22	791120	End Bracket	2
23	791115	Mast Weldment	1
24	791139	Category 2 Top Link Pin	1
25	791138	Category 1 Top Link Pin	1
26	791113	Lower Pivot Weldment	1
27	791119	Horizontal Bracket	2
28	788243	Latch Rod	1
29	788244	Latch Rod Pin	1
30	788245	Latch Spring	1
31	790472	Beam Pivot Pin	1
32	791183	Vertical Latch Pin	1
33	791108	Tow Bar Weldment	1
34	778674	Cotter Pin	1
35	790522	Horizontal Beam Lock	1
36	791355	Powerhorse Beam Decal	2
37	790471	Manual Tube	1

Summary of Important Safety Information for Operation



WARNING

Carefully read and make sure you understand the following safety information before using the log splitter. Improper use or maintenance of the log splitter can result in serious injury to the operator or bystanders from moving parts that can crush or cut, flying objects, burns, fire or explosion, escaping high pressure hydraulic fluid, or carbon monoxide poisoning.

Introduction

- **Read Manual.** Read this operator's manual and the engine Owner's Manual completely before attempting to use the log splitter. Serious injury or death can result if safety instructions are not followed.
- **Instruct operators.** The log splitter owner should instruct all operators in safe log splitter operation.
- **Intended use.** Log splitters should only be used for splitting wood logs, lengthwise with the grain. Do not use for other purposes, as unforeseen hazards may result.

Prohibition Against Modifications

Never modify or alter the log splitter in any way. Modifications can create serious safety hazards and will void the warranty.

- **Attachments.** Never add attachments to the splitter, except for authorized accessories supplied by the manufacturer with instructions for safe installation and use.
- **Remote Control.** NEVER attach a rope, cable, or other remote device to the splitting control.
- **Splitting Wedge.** NEVER attempt to change the height or speed of the splitting wedge.
- **Pressure Setting.** NEVER increase the pressure setting of the pump or control valve.

Operator Restrictions

- **Untrained Operators.** Do not allow anyone to operate the log splitter who has not read the owner's manual or been instructed on the safe use of the splitter.
- **Minimum Operator Age.** Never allow anyone under age 16 to operate the log splitter. Anyone 16 years of age and older must be trained and supervised by a trained adult.

Safety in Connecting to Tractor & Transporting



WARNING

The log splitter must be correctly mounted and then attached to the tractor hydraulic system for safe operation. Follow the instructions below for safely moving and towing the log splitter.

Safety in Connecting Log Splitter to Tractor

- **Read tractor instructions.** Review tractor manual or get instructions from your tractor dealer about how to properly connect the log splitter to your tractor's auxiliary hydraulics.
- **Engage tractor brake.** Make sure the tractor's parking brake is engaged while you are attaching the log splitter.
- **Tractor off.** The tractor engine must be off while mounting the log splitter and making connections to the tractor's hydraulics.
- **Check mounting.** An improperly mounted log splitter could become dislodged during transportation or operation, which could result in serious injury to the operator or bystanders. Do not drive the tractor or operate the log splitter until you are sure the log splitter is properly mounted and hitch pins are fully engaged.
- **Check hydraulic connections/fittings.** Make sure all hydraulic line fittings are tight before applying pressure. High fluid pressures and temperatures are developed in the hydraulic system. Hydraulic fluid escaping through even a tiny opening can burn or puncture skin, resulting in wounds that could cause blood poisoning, infection, amputation or death. If injured by escaping hydraulic fluid, no matter how small the wound is, see a doctor at once.

Summary of Important Safety Information for Operation

Safety in Transporting to Job Site

- **Read tractor instructions.** Review safety instructions in your tractor manual with regard to driving with 3-point hitch mounted equipment attached.
- **Securely attached.** Be sure the log splitter is securely attached before transporting.
- **Added length.** Be aware of the added length of the splitter.
- **Reduced road stability.** Be aware that heavy, 3-point hitch mounted equipment can reduce road stability, regardless of the amount of front-end counterweight added. Drivers should take extra caution when driving with the log splitter attached. Reduce your speed and take extra caution during turns or while driving on rough or sloped terrain.
- **Rough terrain.** Be extra cautious and drive slowly when traveling over rough terrain.
- **No riding or cargo on splitter.** Never ride or transport cargo on the log splitter.
- **Under the influence.** Never tow or operate this splitter while under the influence of alcohol, drugs, or medication.
- **On public roads.** If transporting the log splitter on a public road, make sure to comply with all local, state, and federal towing requirements. It is the sole responsibility of the purchaser to obtain licensing, trailer lights, safety chains or signage, as needed to comply.
- **Unattended.** Turn off the tractor and engage parking brake before leaving the splitter unattended.
- **Engage brake before operation.** Engage tractor's parking brake before operating log splitter.

Safety – Before Use

Read/instruct

- **Read manual.** Do not allow anyone to operate the log splitter who has not read the owner's manual or has not been instructed on the safe use of the splitter.
- **Review safety rules.** Before starting this log splitter, review the "Rules for Safe operation." Failure to follow these rules may result in serious injury to the operator or bystanders.
- **Know how to stop.** Be thoroughly familiar with all controls and proper use of the equipment. Know how to stop the splitter and relieve system pressures quickly if needed.

Personal protective equipment

- **Eye protection.** Always wear safety glasses or goggles when operating the machine. Pieces of log may fly out and serious eye injury can occur.
- **Boots.** Falling logs can crush feet. Always wear safety shoes or heavy boots when operating or helping to load logs.
- **Loose/dangling.** Loose or dangling apparel can become entangled in moving parts. Never wear jewelry or loose-fitting clothing.
- **Gloves.** Wear snug fitting gloves without drawstrings or loose cuffs.
- **Hearing Protection.** The use of earplugs or other hearing protection device is recommended.

Safety During Inspection/Maintenance

Always inspect your log splitter before each use, and repair as needed, to keep it in safe working condition:

- **Engine off.** Always make sure the tractor engine is off before cleaning, repairing or adjusting the splitter, except as recommended by the manufacturer.
- **Other debris.** Debris on moving parts can cause excess wear. With the tractor engine off, clear debris from moving parts.
- **Mechanical parts.** Check to be sure that all nuts and bolts are tight to make sure the log splitter is in safe working condition.

Summary of Important Safety Information for Operation

- **Hydraulic system.** Check the hydraulic system (hoses, tubing, clamps/fittings, pump, and cylinder) carefully before each use. Do not operate the log splitter with frayed, kinked, cracked or damaged hydraulic hoses, fittings, or tubing, or if oily residue is observed on any of the components. High fluid pressures and temperatures are developed in the log splitter. Hydraulic fluid escaping through a pin hole sized opening can burn or puncture skin, resulting in wounds that could cause blood poisoning, infection, disability, gangrene, amputation, or death. Therefore, the following instructions should be heeded at all times when inspecting or servicing the hydraulic components of the log splitter:
 - Do not remove the hydraulic oil fill/vent cap when the engine is running. Hot oil can escape causing severe burns. Allow log splitter to cool completely before removing hydraulic oil fill/vent cap.
 - Do not adjust the pressure setting of the pump or valve.
 - Do not check for leaks with your hand. Leaks can be located by holding a piece of cardboard or wood (at least two feet long) with your hand at one end and passing the other end over the suspected area (wear eye protection). Look for discoloration of the cardboard or wood.
 - Stop the tractor engine and move all control valve handles back and forth to relieve pressure before changing or adjusting hydraulic system components such as hoses, tubing, fittings or other components.
 - If injured by escaping fluid, no matter how small the wound is, see a doctor at once. A typical injection injury may be a small puncture wound that does not look serious. However, severe infection or reaction can result if proper medical treatment is not administered immediately by a doctor who is familiar with injection injuries
- **Guards / shields.** Make sure all guards and shields are replaced after servicing the log splitter.
- **Replacement parts.** If a part needs replacement, only use parts that meet the manufacturer's specifications. Replacement parts that do not meet specifications may result in a safety hazard or poor operation of the log splitter.

Safety in Work Site Selection

- **Hot exhaust.** Hot exhaust fumes from the tractor engine can cause fire. Position exhaust and other hot elements of engine at least 7' from combustible objects during operation.
- **Fire extinguisher.** Have a Class B fire extinguisher available as a precautionary measure when operating the log splitter in dry areas.
- **Level, dry surface.** To prevent accidental falls and equipment tip over, make sure the splitter is situated on a dry, level surface with good footing. Stay clear of areas with mud, ice, tall grass, weeds, brush, or snow.
- **Engage parking brake.** Always engage the tractor's parking brake before operating the splitter to prevent unintended movement.
- **Carbon monoxide.** The running tractor engine gives off carbon monoxide, a poisonous gas that can kill you. You CANNOT smell it, see it, or taste it. ONLY run log splitter OUTDOORS and away from air intakes. NEVER run log splitter inside homes, garages, sheds, or other semi-enclosed spaces. These spaces can trap poisonous gases, EVEN if you run a fan or open windows. If you start to feel sick, dizzy, or weak while using the log splitter, shut off the tractor engine and get to fresh air RIGHT AWAY. See a doctor. You may have carbon monoxide poisoning.

Safety – During Use

 **WARNING:** Before starting this log splitter, review the following rules for safe operation. Failure to follow these rules may result in serious injury to the operator or bystanders.

General Safety During Use

- **Safety equipment / controls.** Always operate the log splitter with all safety equipment in place and in good working order, and all controls properly adjusted for safe operation.
- **Operating speed.** Always operate the log splitter at the manufacturer's recommended speed. You must adjust the tractor engine speed so the flow rate does not exceed 11 GPM. Make sure to see the tractor specification for determining relationship between flow rate and engine speed since a higher flow rate makes the wedge move dangerously fast.

Summary of Important Safety Information for Operation

- **Know how to stop.** Be thoroughly familiar with all controls and with the proper use of the equipment. Know how to stop the log splitter and relieve system pressures quickly if needed.
- **Daylight only.** Only use the log splitter in daylight so you can see what you are doing.
- **Smoking / sparks.** Never smoke while operating the log splitter, and never operate near sources of sparks or flames.
- **Unattended.** Never leave the machine unattended while the tractor engine is running.
- **Under the influence.** Never operate, or let anyone else operate, the log splitter while under the influence of alcohol, drugs, or medication.
- **Adjusting / repairing.** Always make sure the tractor engine is off before cleaning, repairing or adjusting the splitter, except as recommended by the manufacturer. In addition, move all control handles back and forth to relieve system pressure *before changing or adjusting hydraulic system components* such as hoses, tubing, fittings or other components.
- **Carbon monoxide.** The running tractor engine gives off carbon monoxide, a poisonous gas that can kill you. You CANNOT smell it, see it, or taste it. If you start to feel sick, dizzy, or weak while using the log splitter, shut off the tractor engine and get to fresh air RIGHT AWAY. See a doctor. You may have carbon monoxide poisoning.
- **Other exhaust dangers.** Engine exhaust, some of its constituents, and certain vehicle components contain or emit chemicals known to the State of California to cause cancer, birth defects, or other reproductive harm. Avoid inhalation of exhaust.

Safety in Loading, Operating, and Unloading

- **Square log ends.** Logs that are not cut square can slide out while splitting and become a safety hazard or cause excessive force to log splitter components. Use a chainsaw to cut logs square on each end before attempting to split them.
- **Single log.** Never attempt to split more than one log at a time. Pieces of log can unexpectedly be thrown from the machine causing serious injury.
- **Split along grain.** Do not use the log splitter to split logs across the grain. Doing so will damage the log splitter and could also cause pieces of log to be thrown, injuring the operator or bystanders.
- **Keep hands clear.** ALWAYS keep hands and feet away from the endplate, wedge, and partially split logs while loading, operating and unloading the log splitter.
- **Operator position.** ALWAYS operate the log splitter from the manufacturer's indicated OPERATOR POSITION. Other positions are unsafe because they can increase the risk of injury from crushing, cutting, flying objects, or burns.
- **Straddling / reaching across.** Never straddle, reach across, or step over the beam while the engine is running and the log splitter is in the horizontal position. You could trip, actuate the controls, and get seriously injured.
- **Second person.** Many accidents occur when there is more than one person involved in loading and operating the log splitter. Only one person should operate the controls. *If a second person is assisting in loading logs, the operator must NEVER actuate the Split Control Lever until the assistant and all bystanders are at least 10 feet away. NEVER allow an assistant to hold the log in place while the operator actuates the Split Control Lever.*
- **Loading/Unloading**
 - **Unsplit log pile.** Do not pile logs to be split in a place that will make you reach across the log splitter in order to load them.
 - **Hold bark side.** Hold the bark side of logs when loading or positioning, never the ends. Never place your hands or any part of your body between a log and any part of the log splitter.
 - **NOTE for vertical position loading:** Place the log on the endplate and turn it until it leans against the beam and is stable. If the log is too big or oddly shaped, stabilize the log with wooden shims between the log and endplate or ground. DO NOT use your leg or knee to stabilize the log. NEVER stabilize the log by placing your hand on top of the log.
 - **Wedge moving.** NEVER load or unload logs while the wedge is moving.
 - **Cracks.** Cracks in logs can close quickly and pinch fingers. Keep fingers away from any cracks that open in partially split logs.

Summary of Important Safety Information for Operation

- **Split log pile.** Move each log away from log splitter after it is split. Split logs left near the log splitter are a trip hazard.
- **Remove hands.** Remove both hands from log before activating Split Control Lever.
- **Hand activate.** Use only your hand to operate the Split Control Lever. Never use any other body part, or a rope, cable, or other remote device to actuate the control.
- **Returning wedge.** Once the control valve is actuated in the return direction, the wedge is designed to keep returning by itself completely and then stop automatically. Stay clear while the wedge is returning. It is still powerful enough on the return stroke to cause serious injury.
- **Log stuck on wedge.** If a log does not split completely and becomes stuck on the wedge, follow the instructions below to remove the log. A log can become stuck to the wedge if the wedge becomes embedded in the log and the log doesn't split and separate. This can happen if the log is too stringy or tough to split completely. A stuck log will move back with the wedge on the initial attempt to retract the wedge. If this happens, retract the wedge completely to allow the splitter to strip the log from the wedge. Keep hands clear of log and wedge while wedge is retracting.

⚠ WARNING: NEVER attempt to remove a stuck log by:

- Modifying the splitter.
- Adding attachments to the splitter.

Personal injury could result from log or metal pieces flying out at high speed toward the operator or bystanders, or the splitter could become damaged.

Safety – After use

- **Return to horizontal.** If in the vertical position, return log splitter to the horizontal position for greater stability and to prepare for transportation.
- **Storage location.** Store the log splitter in a location away from corrosive material.
- **Periodic maintenance.** Perform periodic maintenance as directed in this manual to keep the log splitter in safe working condition.

Assembly Instructions

Closely inspect all log splitter components.

If you have missing or damaged components, please contact Powerhorse Product Support at 1-866-443-2576.



CAUTION

Heavy lifting required. Some of the components in these assembly instructions are heavy and cannot be lifted by one person safely. Please plan on assembling this product when another person can be available to help out.



CAUTION

Remove the cylinder from the beam assembly before assembling. The cylinder is locked in place for shipping purposes in a backwards orientation.



CAUTION

Ensure work area is safe, level and free of any live wires or machinery.



CAUTION

Hose clamp orientation: When assembling hose clamps, orient the runout-tab so that it is out of the way of any interaction points on the log splitter

Tools needed: Adjustable Wrenches, Torque Wrench, Pliers

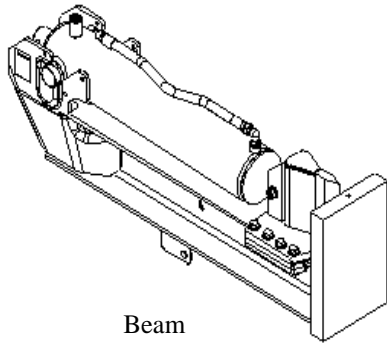

Beam
Assembly

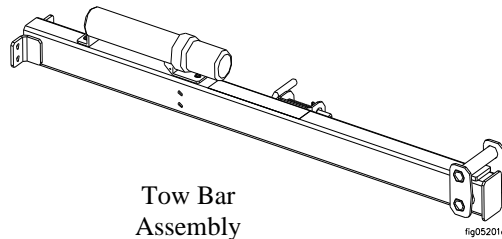

Tow Bar
Assembly

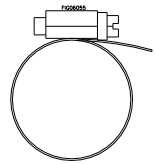

Runout-
Tab

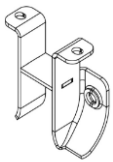

Horizontal
Latch
Bracket

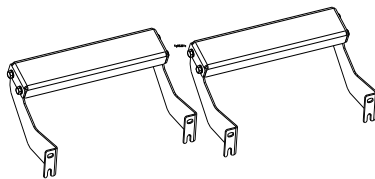

Log
Cradles

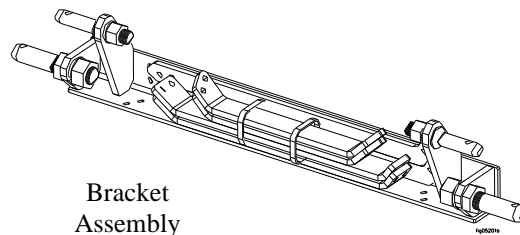

Bracket
Assembly

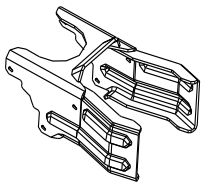

Log
Stripper

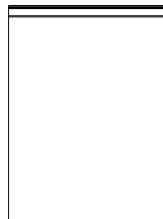

Manual
Bag

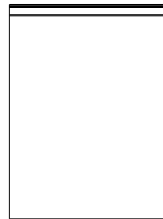

Parts Bag

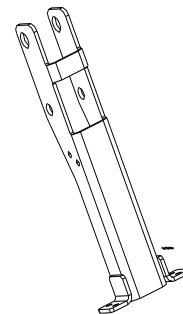

Mast

Assembly Instructions

Bracket Assembly Contents:

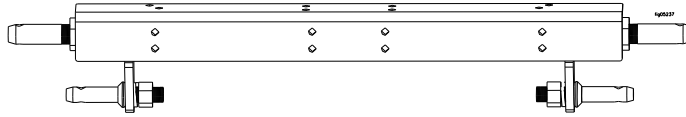

Lower Pivot
Assembly

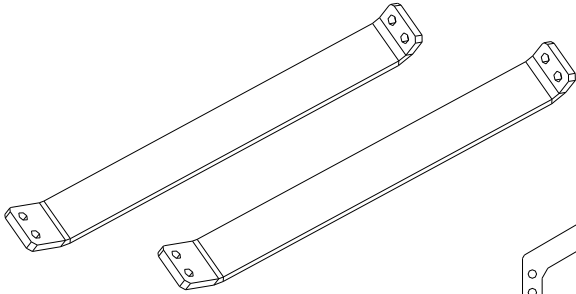

Horizontal
Brackets

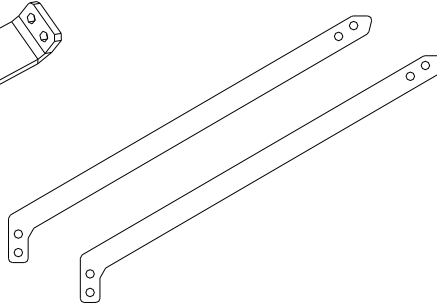

Vertical
Brackets

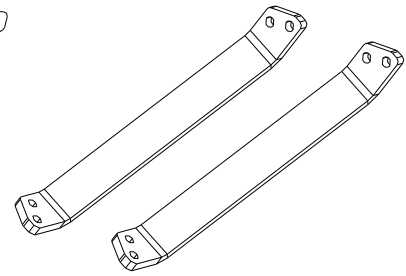

Side Brackets

Manual Bag Contents:

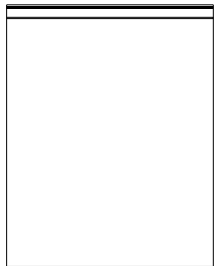

Owner's
Manual

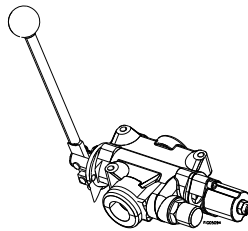

Hydraulic
Valve

Assembly Instructions

Fastener Bag Contents: Actual fastener size shown in the assembly steps

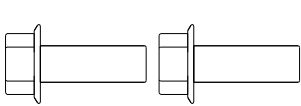

Horizontal Latch to Beam
M12-1.75 X 35 HHSF
Part # 82551
Qty: 2

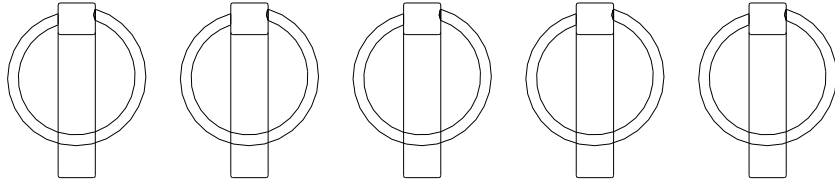

Lynch Pin
Part # 39159
Qty: 5



Cotter Pin
Part # 778674
Qty: 1

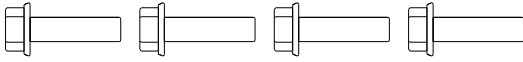

Cradles to Beam
M8-1.25 X 30 HHSF
Part # 82545
Qty: 4

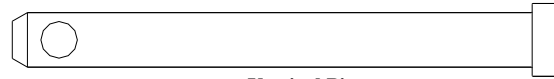

Vertical Pin
Part # 791183
Qty: 1

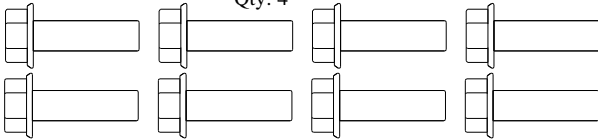

Bracket Assembly
M10-1.5 X 35 HHSF
Part # 82535
Qty: 8

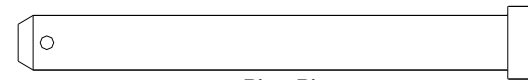

Pivot Pin
Part # 790472
Qty: 1

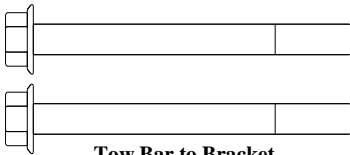

Tow Bar to Bracket
M10-1.5 X 105 HHSF
Part # 82558
Qty: 2

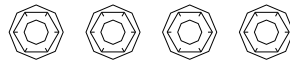

Log Cradles to Beam
M8-1.25 Nut
Part # 82281
Qty: 4



Cat 2 Top Link Pin
Part # 791139
Qty: 1

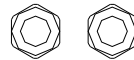

Tow Bar to Bracket
M10-1.5 Nyloc Nut
Part # 82270
Qty: 2



Cat 1 Top Link Pin
Part # 791138
Qty: 1

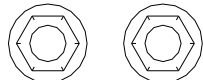

Horizontal Bracket to Beam
M12-1.75 Nut
Part # 82273
Qty: 2

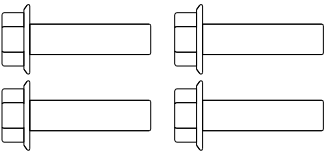

Bracket Assembly
M10-1.5 X 40 HHSF
Part # 82568
Qty: 4

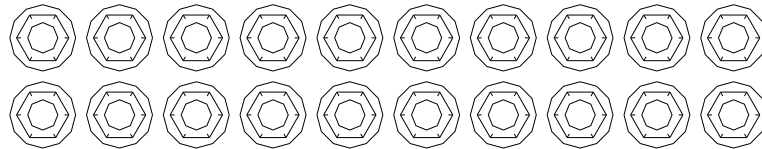

Bracket Assembly
M10-1.5 Nut
Part # 82271
Qty: 20

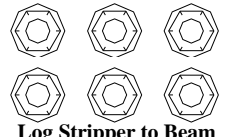

Log Stripper to Beam
M8-1.25 Nut
Part # 82281
Qty: 6

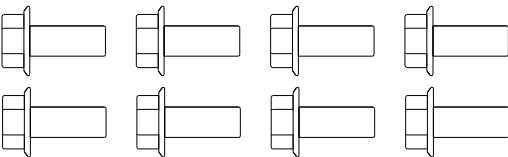

Bracket Assembly
M10-1.5 X 25 HHSF
Part # 82262
Qty: 8

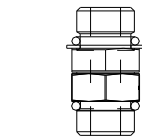

Valve to Cylinder Fitting
Part # 790488
Qty: 1

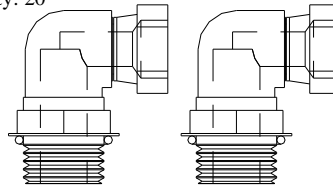

Valve to Hose Fitting
Part # 778831
Qty: 2

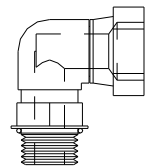

Valve to Cylinder Hose Fitting
Part # 778827
Qty: 1

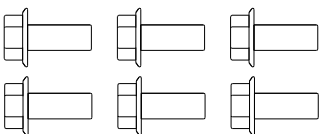

Log Stripper to Beam
M8-1.25 X 25 HHSF
Part # 777494
Qty: 6

Assembly Instructions

Step 1 – Beam Assembly

- Rotate cylinder 180° and place cylinder in trunnion mounts on beam (see Step 2 image for the correct orientation)

Tools Needed

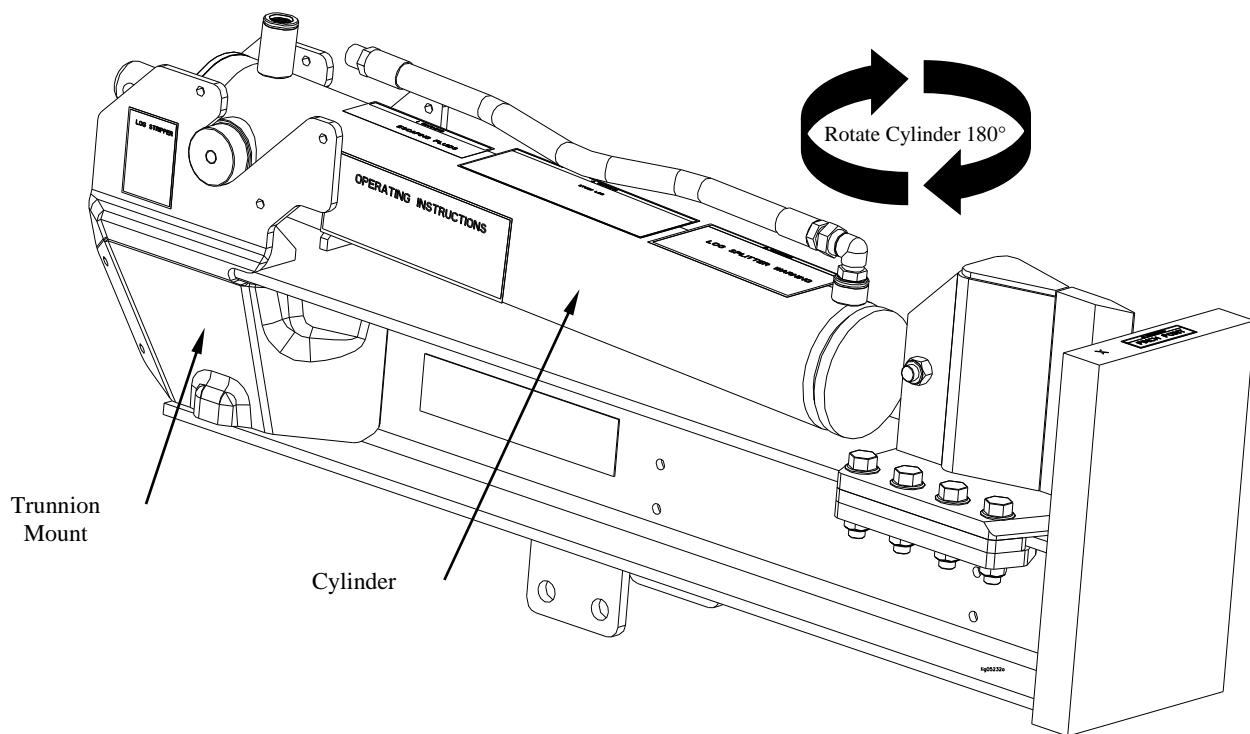

Assembly Instructions

Step 2 – Beam Assembly

- Support the end of the cylinder until connected to the wedge
- Ensure the ports on the cylinder are facing up
- Remove the existing bolt and nut from the wedge
- Slide wedge towards the cylinder rod

Tools Needed

- 22mm Wrench
(2 needed)

Fasteners Needed from Parts Bag:

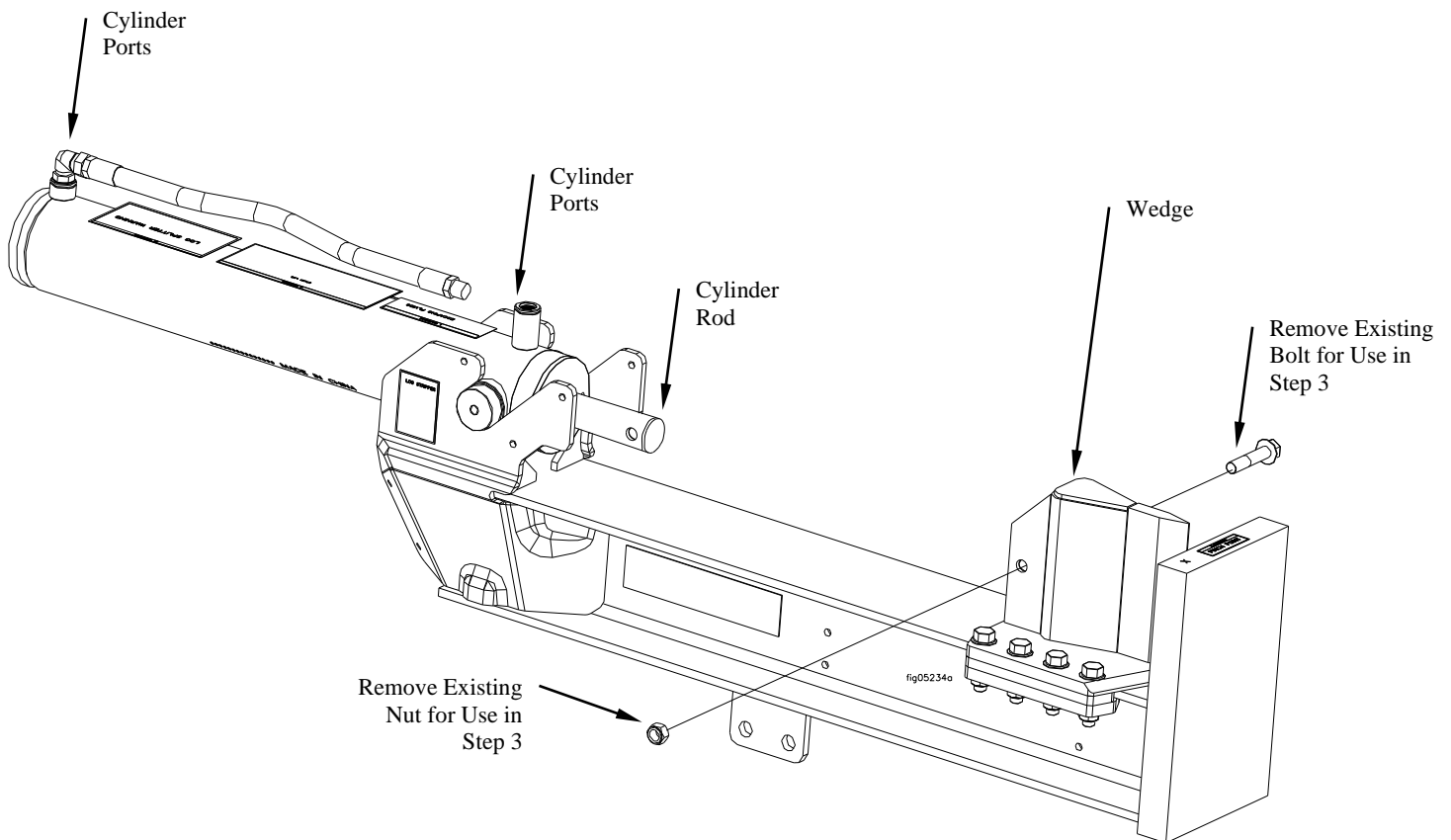

Assembly Instructions

Step 3 – Beam Assembly

- Align hole in wedge with the hole in the cylinder rod
- Install the existing bolt and nut to connect the wedge to the cylinder.
- Torque to 114 ft.-lb.

Tools Needed

- 22mm Wrench (2 Needed)
- Torque Wrench

Fasteners Needed from Parts Bag:

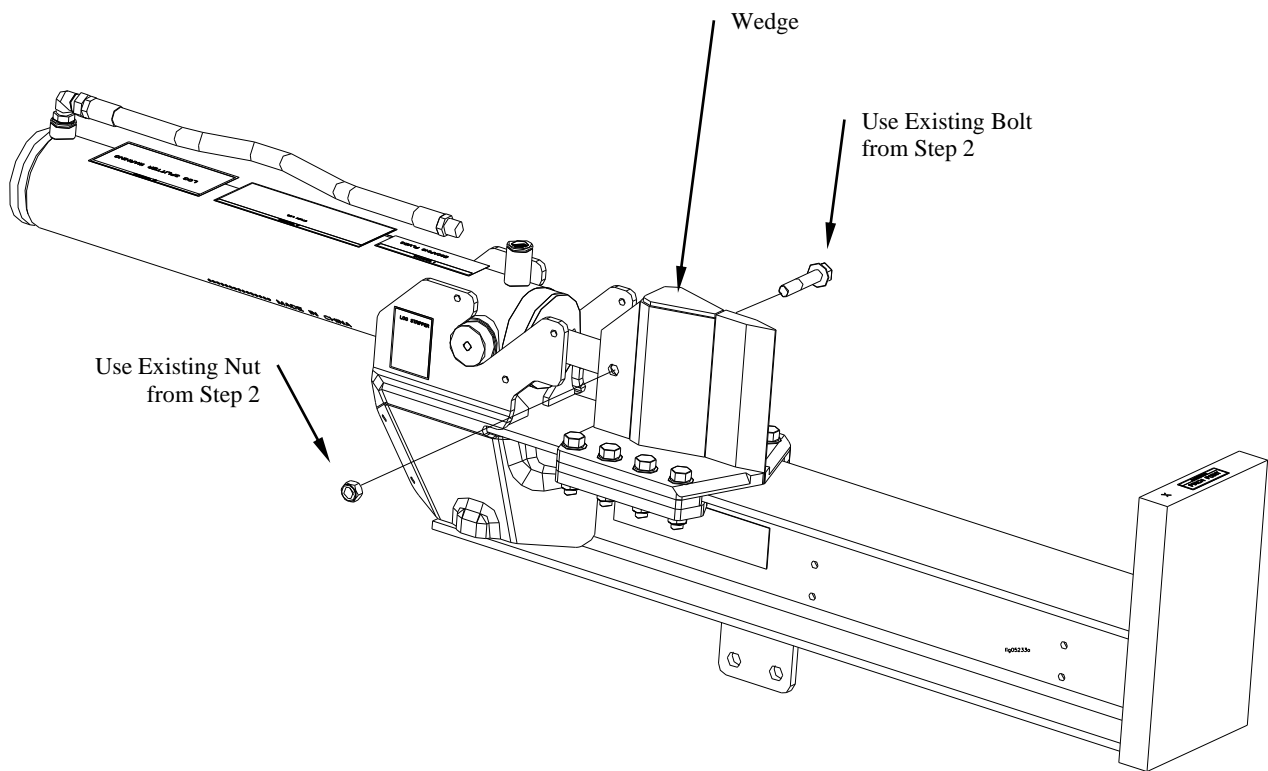

Assembly Instructions

Step 4 – Log Stripper Assembly

- Align holes in the log stripper with the holes in the trunnion mount
- Attach the log stripper to beam using the nuts and bolts from Parts Bag. Torque to 21 ft.-lb.
- Stand assembled beam onto the end plate in the vertical position and move to the side.

Tools Needed

- 13mm Wrench
- Torque Wrench

Fasteners Needed from Parts Bag:

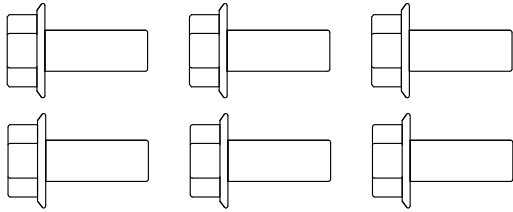

Log Stripper to Beam
M8-1.25 X 25mm Bolt
Qty: 6

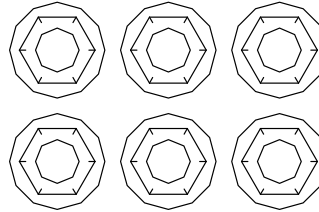

Log Stripper to Beam
M8-1.25 Nut
Qty: 6

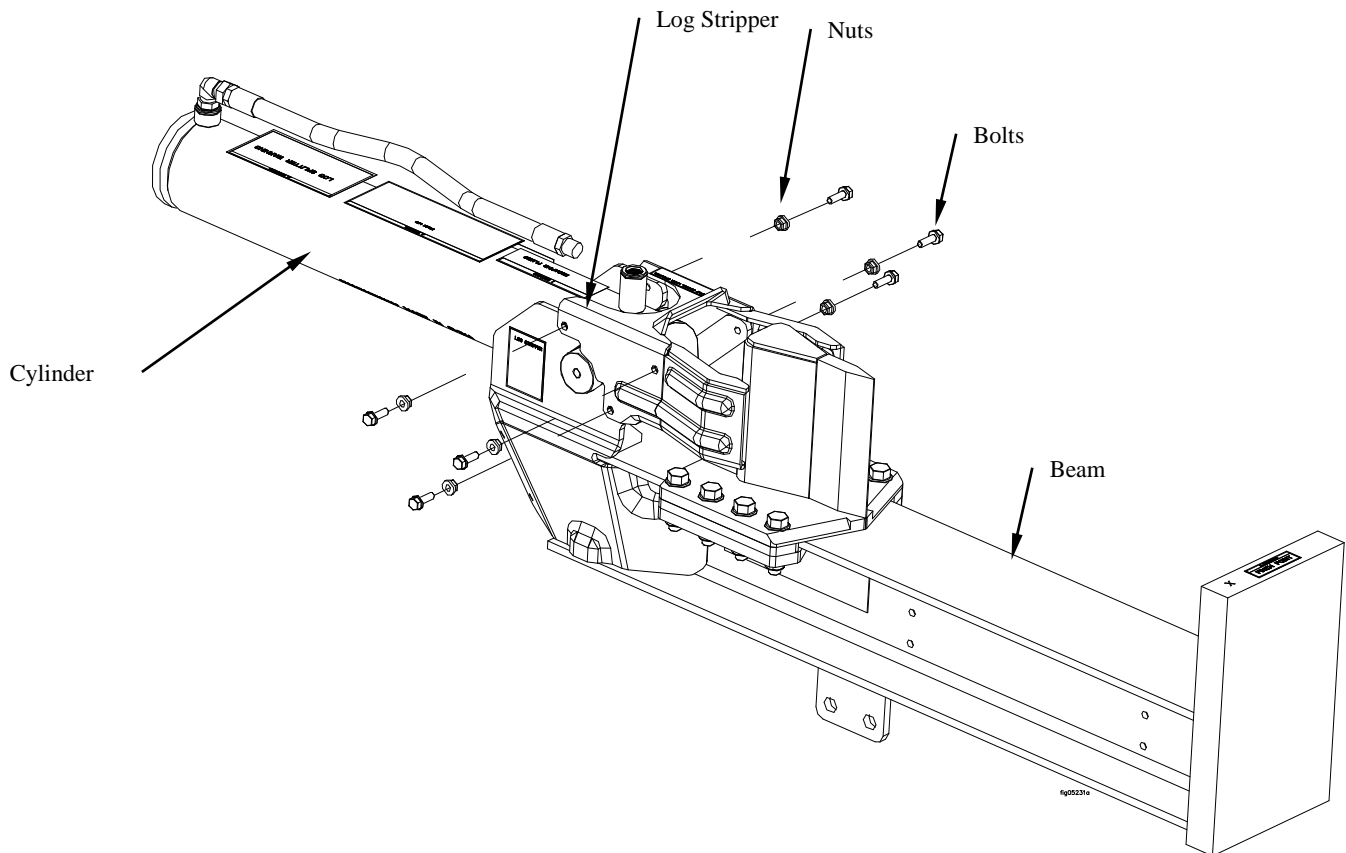

Assembly Instructions

Step 5 – Tow Bar Assembly

- Align holes on the tow bar to the lower pivot assembly.
- Install (4) bolts and (4) nuts and hand tighten to allow for adjustment.
- Fasteners will be torqued to 41 ft.-lb. in Step 7.

Tools Needed

- 15mm Wrench
- Torque Wrench

Fasteners Needed from Parts Bag:

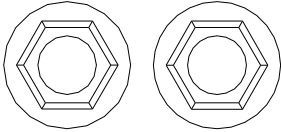

Bracket Assembly
M10-1.5 Nut
Qty: 4

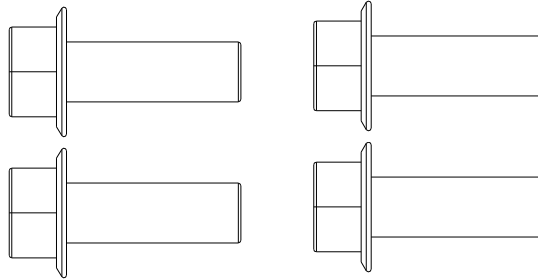

Bracket Assembly
M10-1.5 X 25mm Bolt
Qty: 4

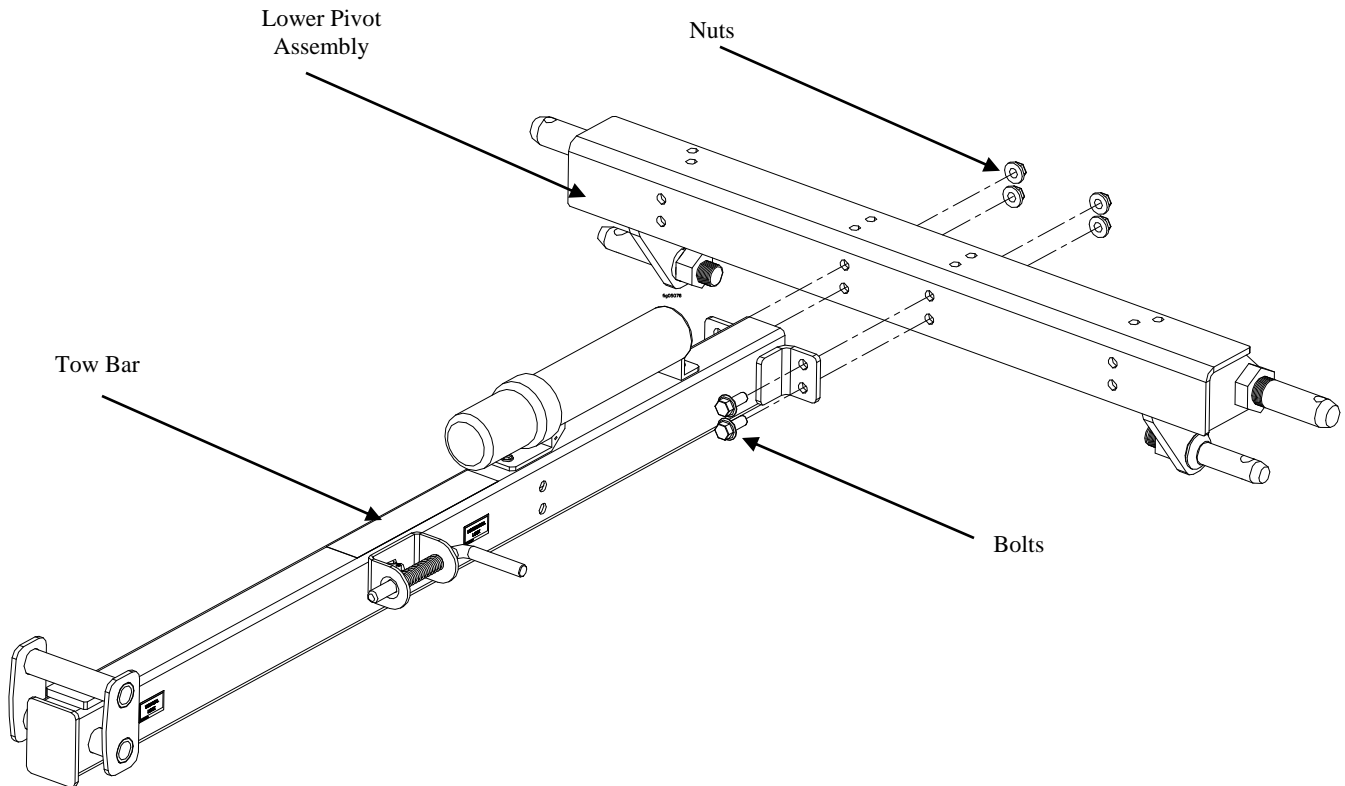

Assembly Instructions

Step 6 – Tow Bar Assembly

- Align holes in mast with the holes in the lower pivot assembly.
- Install (4) bolts and (4) nuts and hand tighten to allow for adjustment.
- Fasteners will be torqued to 41 ft.-lb. in Step 7.

Tools Needed

- 15mm Wrench
- Torque Wrench

Fasteners Needed from Parts Bag:

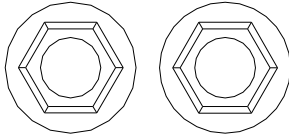

Bracket Assembly
M10-1.5 Nut
Qty: 4

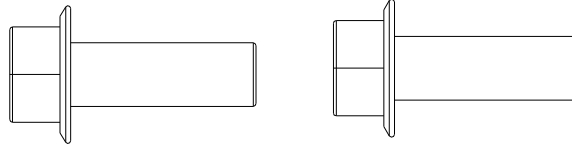

Bracket Assembly
M10-1.5 X 25mm Bolt
Qty: 4

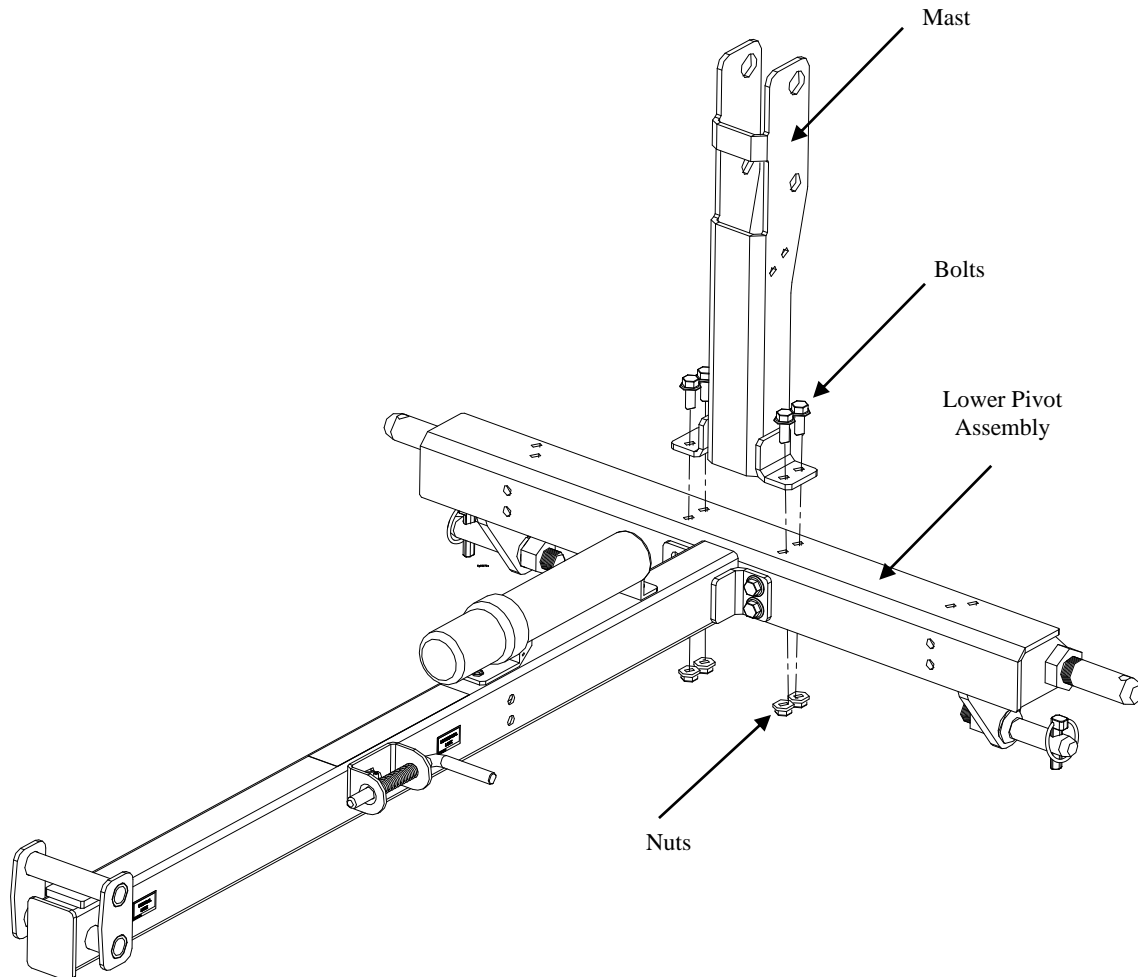

Assembly Instructions

Step 7 – Tow Bar Assembly

- Align horizontal, vertical and side brackets as shown below. Hand tighten bolts initially to allow for movement during bracket assembly.
- Once all pieces are assembled using bolts and nuts from parts bag, torque to 41 ft.-lb.

Tools Needed

- 15mm Wrench
- 16mm Wrench
- Torque Wrench

Fasteners Needed from Parts Bag:

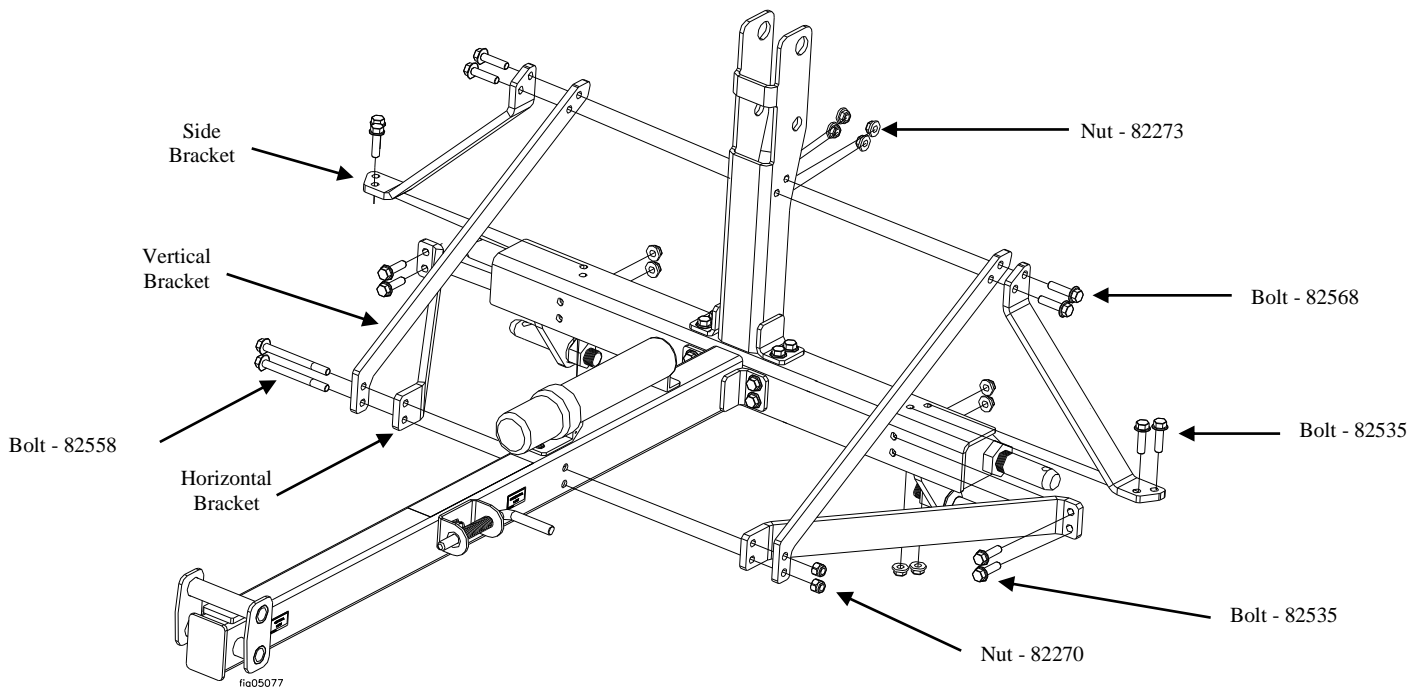
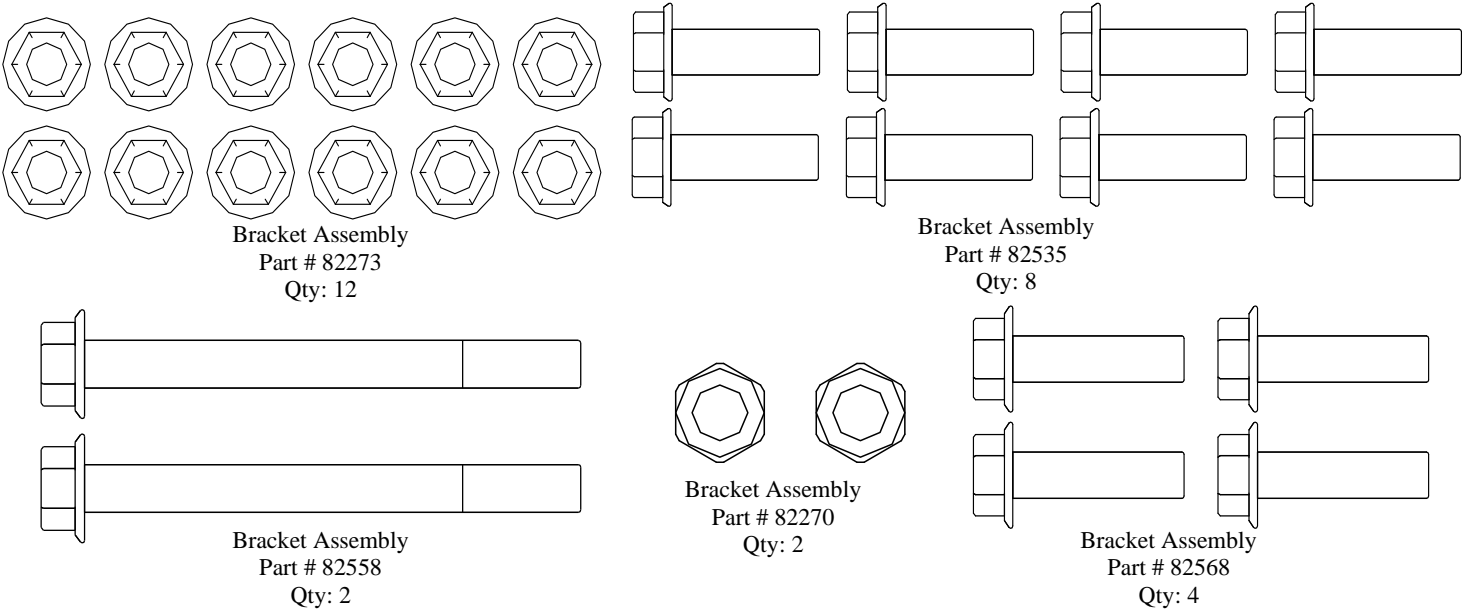

Assembly Instructions

Step 8 – Tow Bar Assembly

- Place tow bar assembly on flat surface and orient as shown below. Make sure a helper holds onto the top of the beam assembly during the remainder of this step. The beam is very heavy and dangerous if it tips over.
- Align the pivot hole on the beam assembly to the pivot hole on the tow bar assembly and insert pivot pin.
- Insert cotter pin through hole in pivot pin. Use pliers to spread and bend prongs in opposite directions to secure.

Tools Needed

- Pliers

Fasteners Needed from Parts Bag:

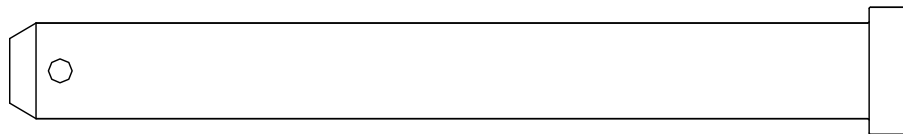

Pivot Pin
Part # 790472
Qty: 1



Cotter Pin
Part # 778674
Qty: 1

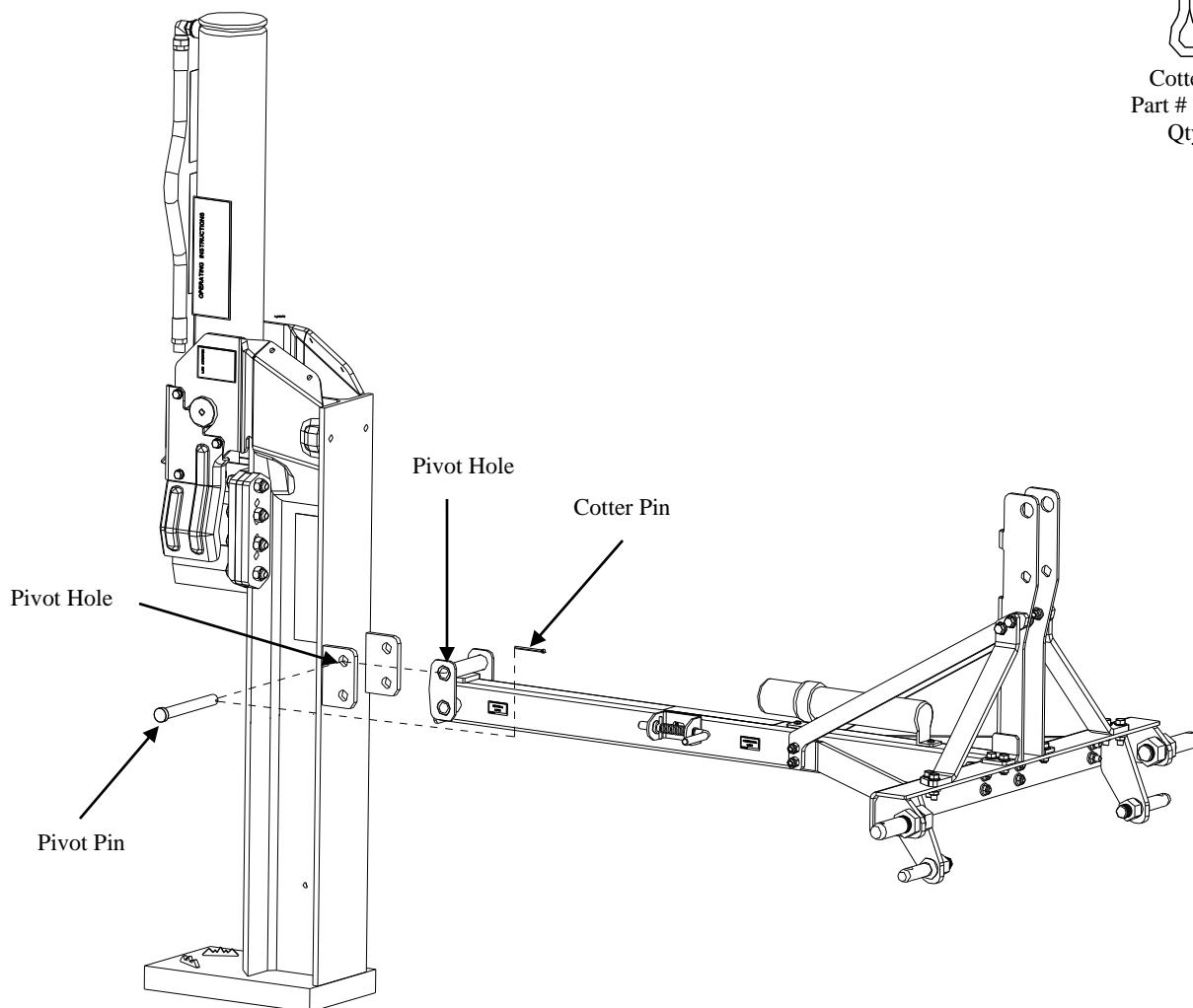

Assembly Instructions

Step 9 – Tow Bar Assembly

- Insert vertical pin through vertical pin hole in tow bar assembly and beam assembly.
- Insert lynch pin through hole in vertical pin to secure.

Tools Needed

Fasteners Needed from Parts Bag:

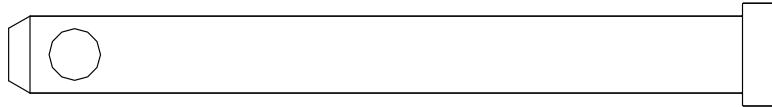

Vertical Pin
Part #: 791183
Qty: 1

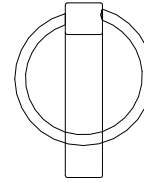

Lynch Pin
Part #: 39159
Qty: 1

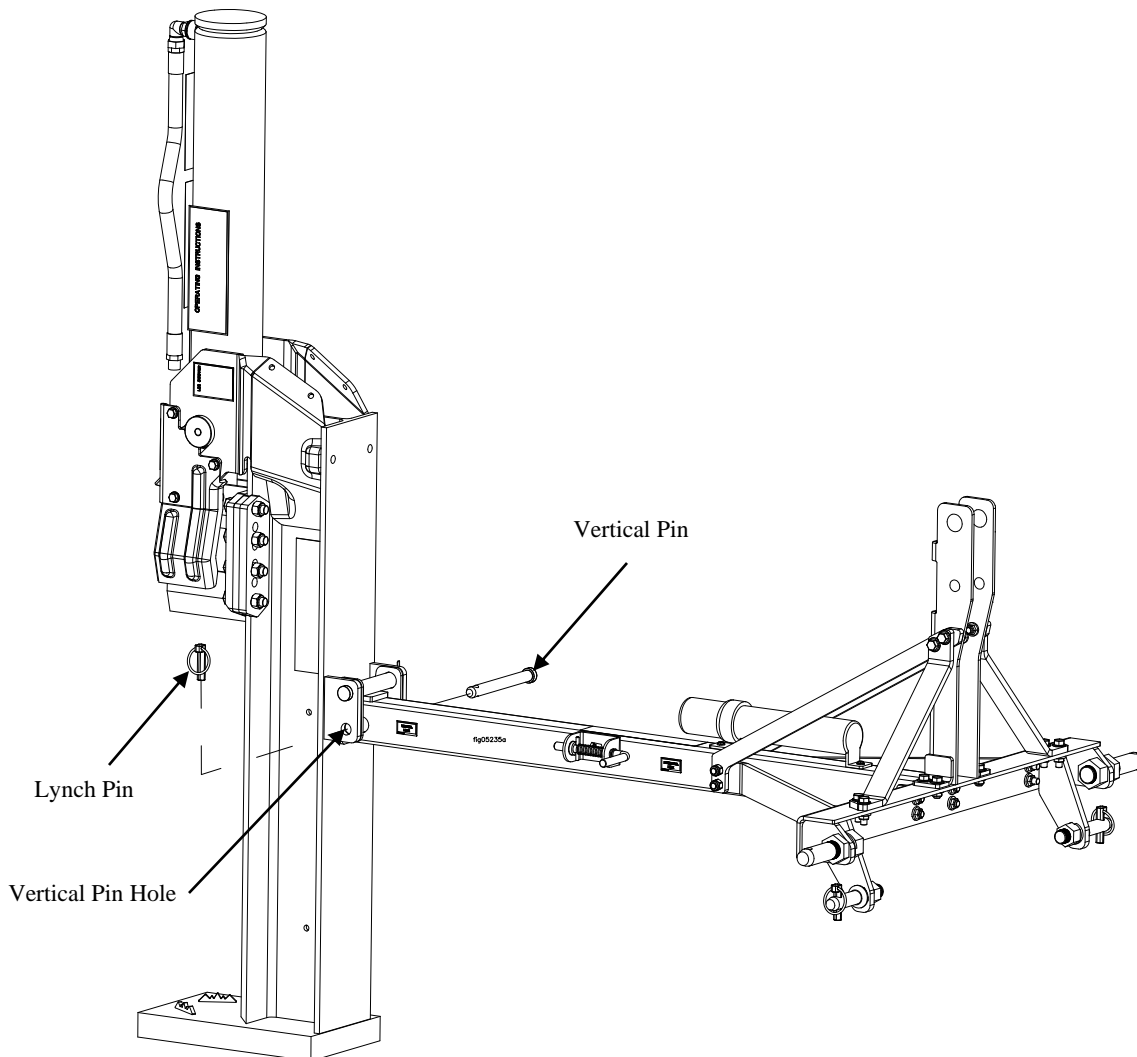

Assembly Instructions

Step 10 – Horizontal Latch Bracket Assembly

- Install the horizontal latch bracket to the beam assembly in orientation shown below, using (2) bolts and (2) nuts.
- Torque to 71 ft.-lb.
- Remove lynch pin from vertical pin and pull out vertical pin.
- Pivot beam to horizontal position, ensure horizontal latch pin locks into the horizontal latch bracket.
- Note: If latch pin does not properly lock into horizontal latch bracket, loosen bolts and adjust until latch pin locks. Torque bolts after adjustment.
- Insert vertical pin and secure with lynch pin.

Tools Needed

- 18mm Wrench
- Torque Wrench

Fasteners Needed from Parts Bag:

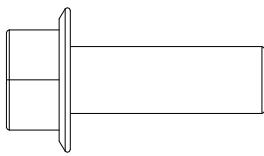

Horizontal Latch to Beam
M12-1.75 X 35mm Bolt
Qty: 2

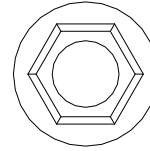
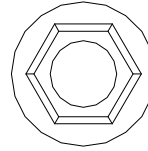
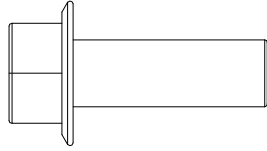

Horizontal Latch to Beam
M12-1.75 Nut
Qty: 2

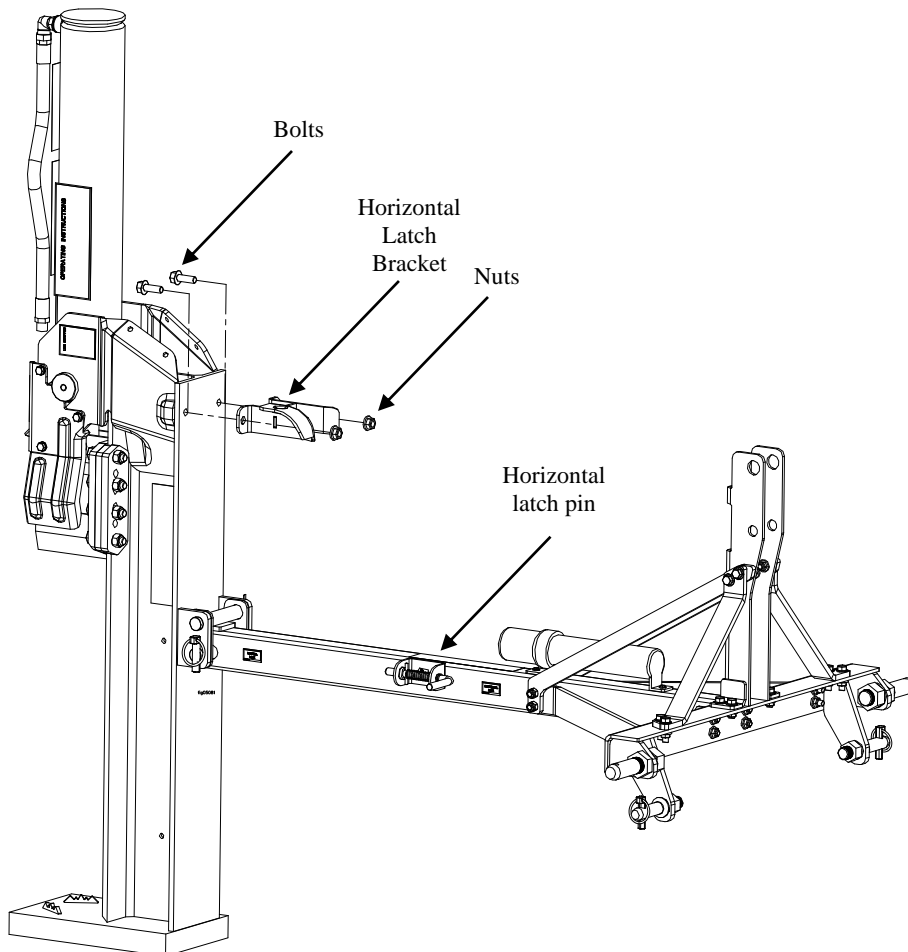

Assembly Instructions

Step 11 – Log Cradle Assembly

- Install (2) bolts and (2) nut into the bottom holes of the beam.
- Using the slots in the bottom of each log cradle arm, rest the log cradle arms on the installed bolts and nuts.
- Install the remaining (2) bolts and (2) nuts into the top holes of the beam and log cradle arms.
- Torque to 21 ft.-lb.

Tools Needed

- 13mm Wrench
- Torque Wrench

Fasteners Needed from Parts Bag:

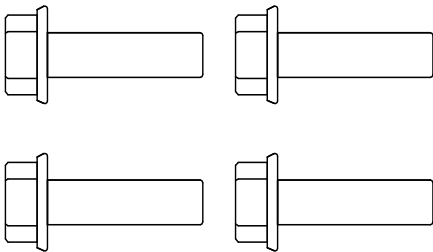

Cradles to Beam
M8-1.25 x 30mm Bolt
Qty: 4

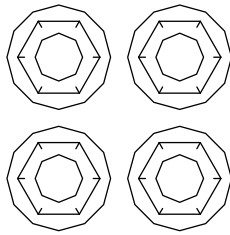

Cradles to Beam
M8-1.25 Nut
Qty: 4

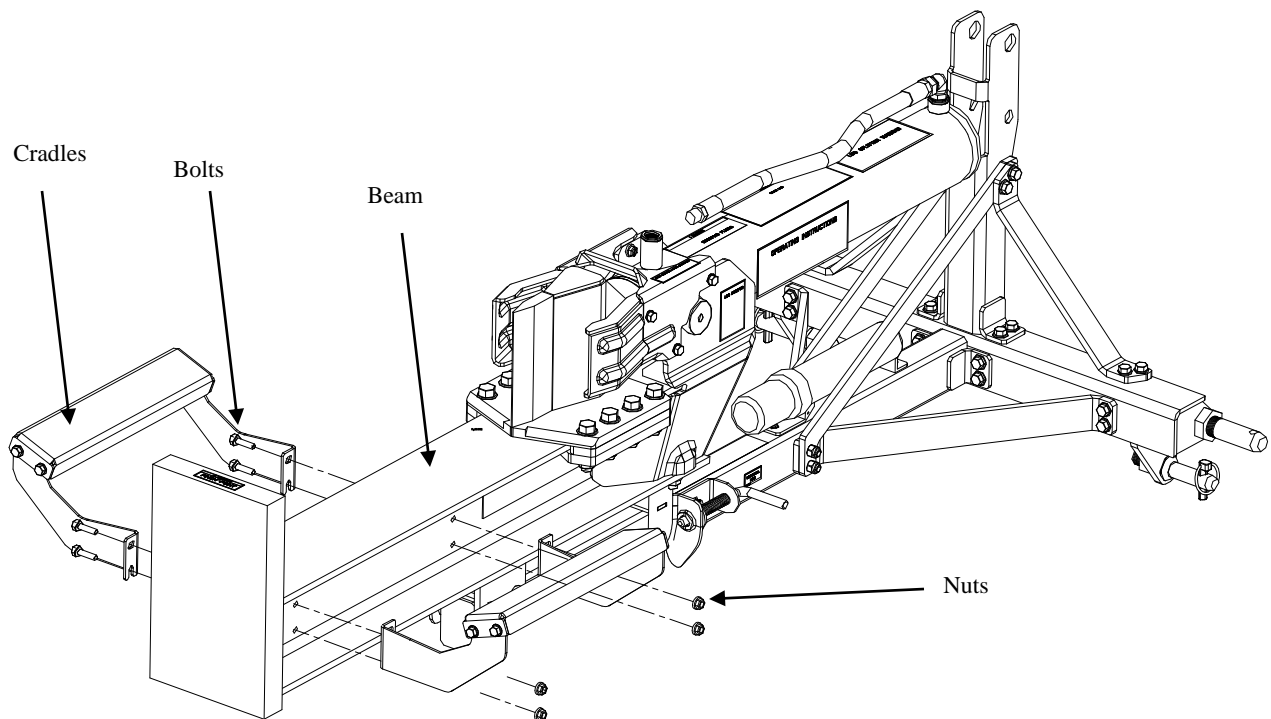

Assembly Instructions

Step 12 – Top Link Pins

- Install Category 1 and Category 2 top link pins into their respective holes.
- Insert (2) lynch pins into top link pins to secure.
- Insert remaining (2) lynch pins into lower link pins according to which Category Link you have.

Tools Needed

Fasteners Needed from Parts Bag:

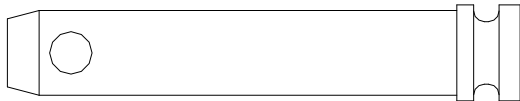

Cat. 2 Top Link Pin
Part #: 791139
Qty: 1

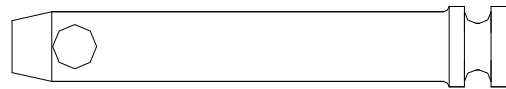

Cat. 1 Top Link Pin
Part #: 791138
Qty: 1

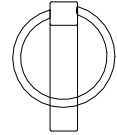

Lynch Pin
Part #: 39159
Qty: 4

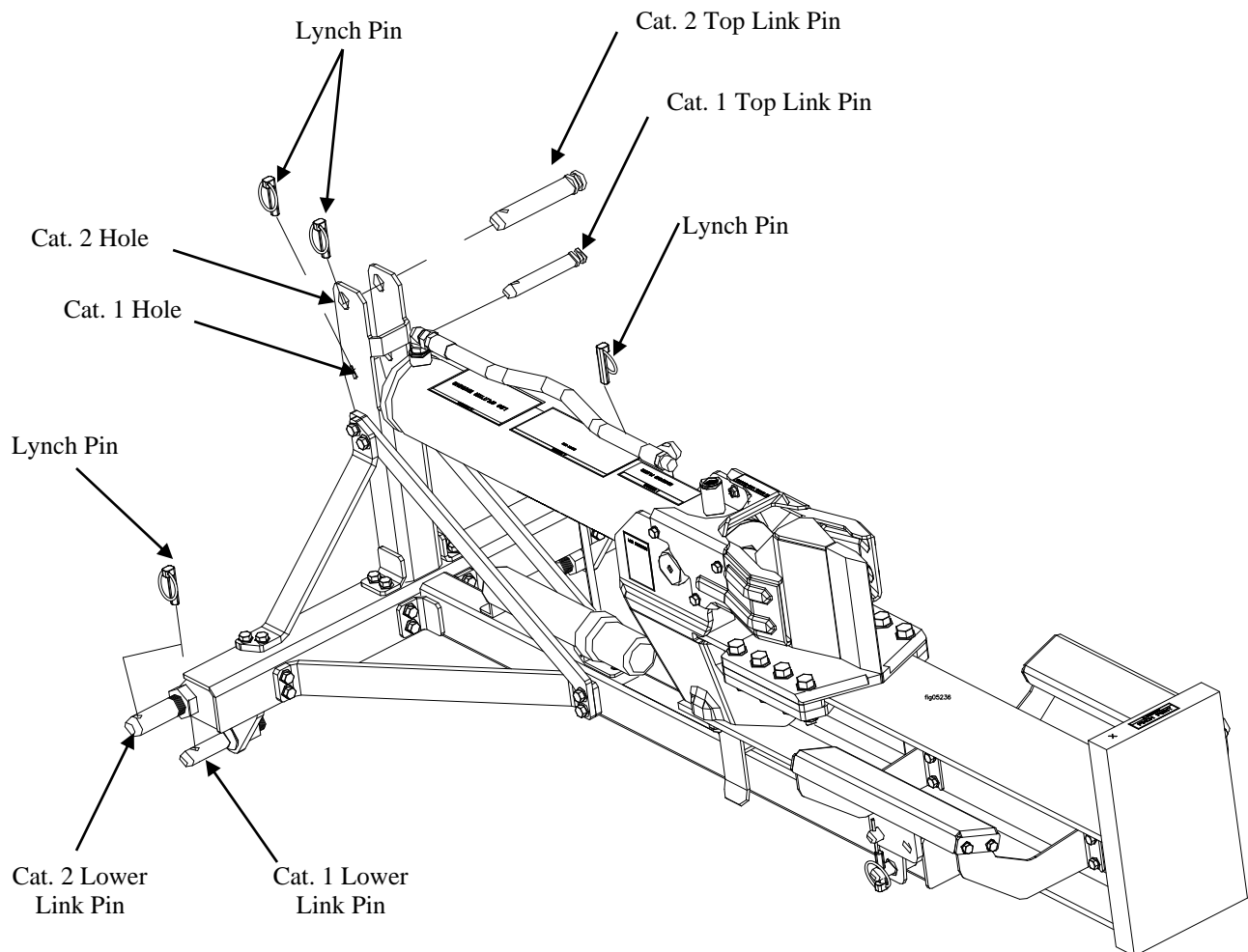

Assembly Instructions

Step 13 – Control Valve

- Slide control valve handle into the clevis slots on the control valve.
- Align holes in handle with clevis holes.
- Insert the supplied pins through holes and secure with supplied bridge clips.

Tools Needed

- Pliers

Parts Needed from Valve Box:

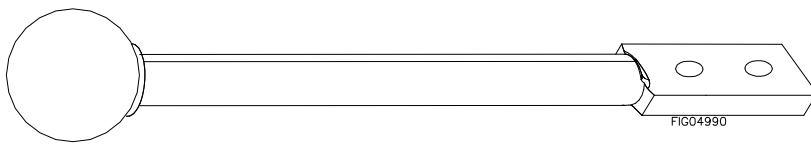

Control Valve Handle
Qty: 1



Bridge Clip
Qty: 2

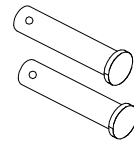

Pin
Qty: 2

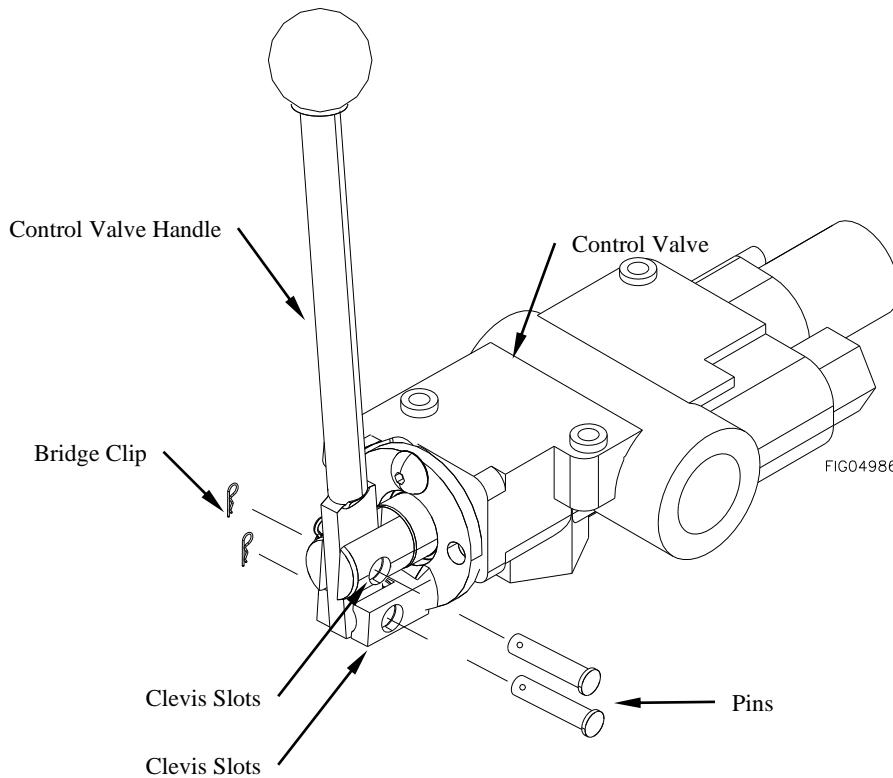

Assembly Instructions

Step 14 -Fittings

- Remove plug from cylinder port and discard
- Lubricate O-ring and threads on fitting with clean oil
- Orientate (1) Valve Fitting so that nut/washer/O-ring assembly is facing up. Turn fitting into cylinder port until finger-tight
- Torque to 27-43 ft.-lb.
- Looking at fitting from end with nut/washer/O-ring assembly, turn nut clockwise as far as possible
- Use valve port marked “A” to thread the control valve onto the fitting until control valve touches washer
- Hold control valve in orientation shown below and torque nut to 37-46 ft.-lb.

Tools Needed

- 7/8” Wrench
(2 needed)
OR
- Crescent Wrench
(2 needed)
- Torque Wrench

Fittings Needed from Parts Bag:

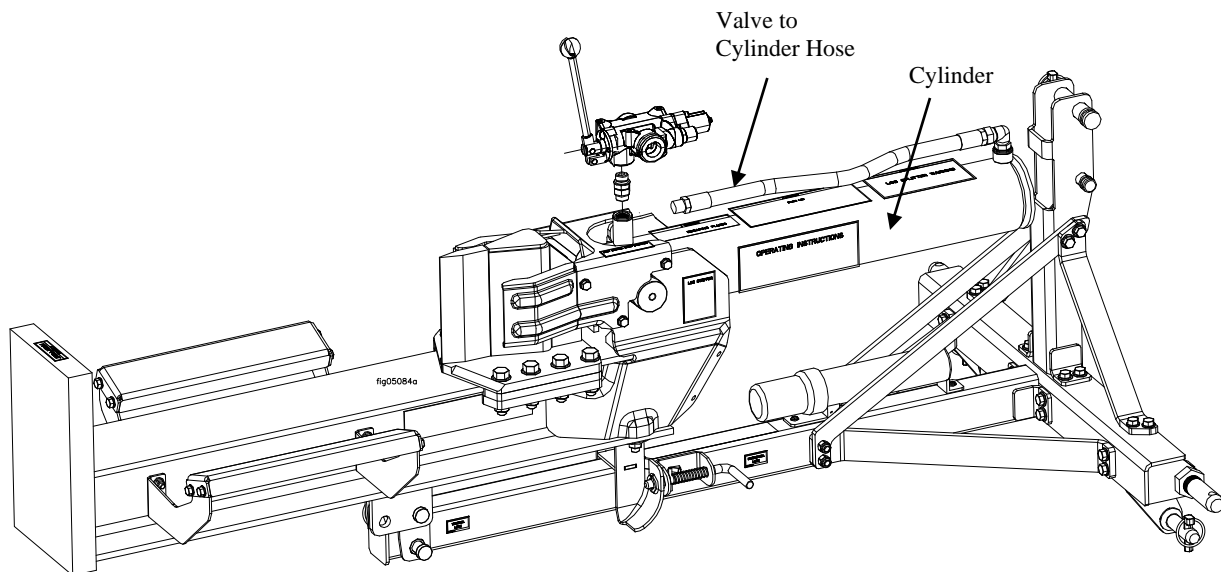
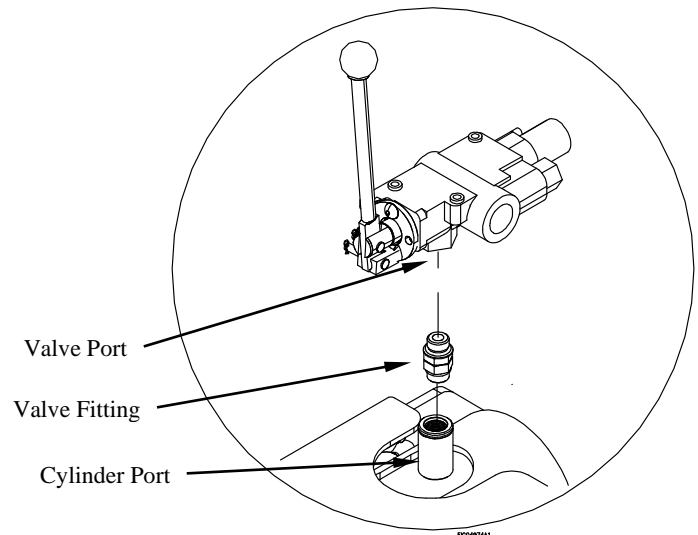
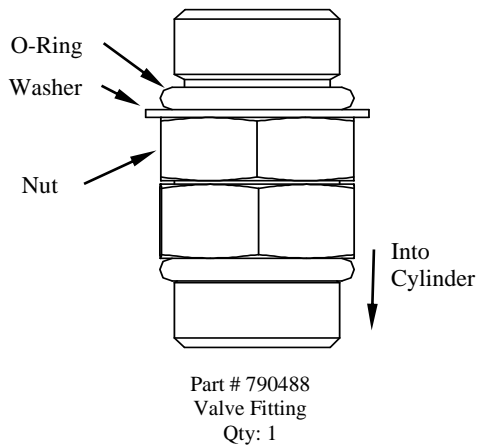

Assembly Instructions

Step 15 - Fittings

- Remove plugs from ports in control valve
- Lubricate O-ring and threads on fitting with clean oil
- Looking at fitting from end with nut/washer/O-ring assembly, turn nut clockwise as far as possible
- Using wrench, turn (1) Valve to Cylinder Hose Fitting into valve port marked "B" until washer touches control valve. Continue turning until washer touches thread nearest wrench pad
- Back off fitting counterclockwise not exceeding one revolution until it is oriented in the correct position
- Place wrench on the wrench pad of fitting to prevent fitting from turning and torque nut to 37-46 ft.-lb.
- Thread Valve to Cylinder Hose Fitting Nut on to Valve to Cylinder Hose.
- Place wrench on hose end fitting to prevent from turning and torque Valve to Cylinder Hose Fitting Nut to 27-34 ft.-lb.

Tools Needed

- 7/8" Wrench
- 3/4" Wrench
- 1" Wrench
- OR
- Crescent Wrench (2 needed)
- Torque Wrench

Fittings Needed from Parts Bag:

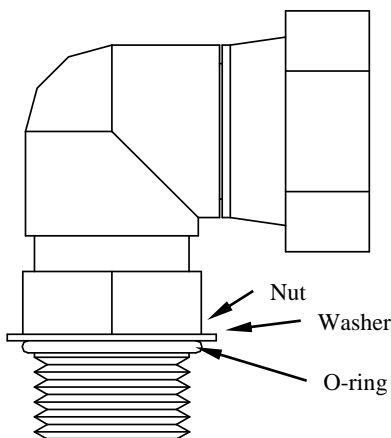

Part # 778827
Valve to Cylinder Hose Fitting
Qty: 1

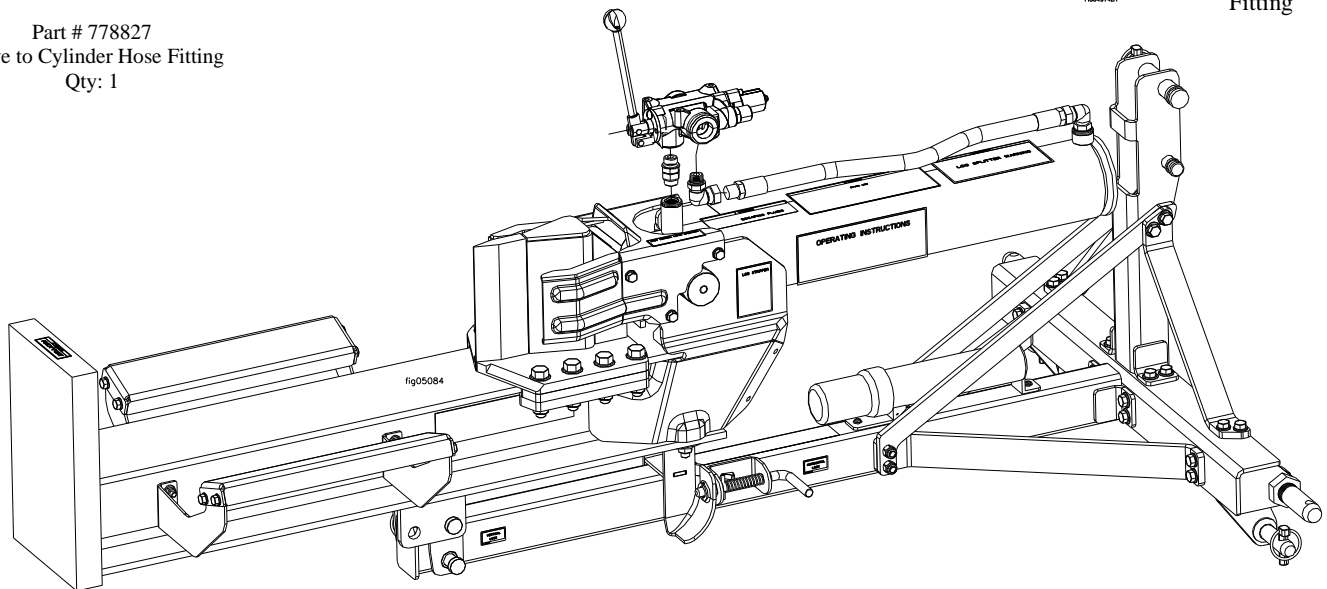
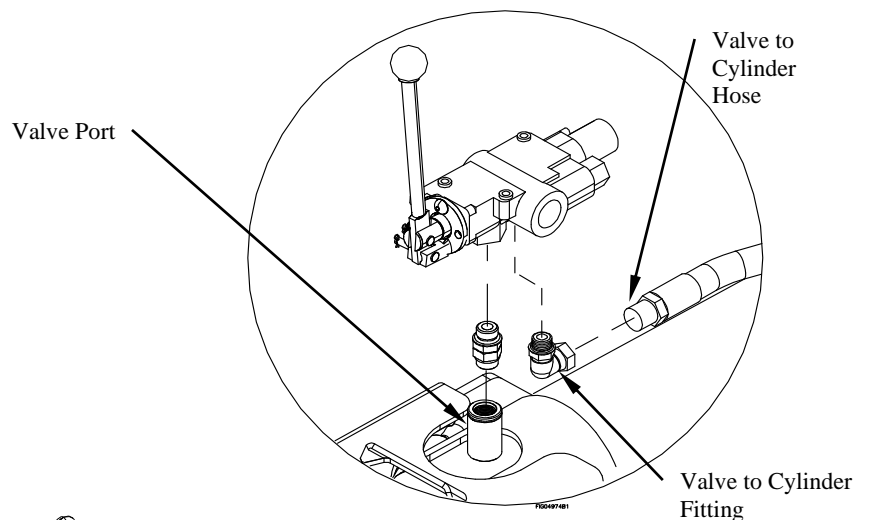

Assembly Instructions

Step 16 - Fittings

- Remove plugs from ports in control valve
- Lubricate O-ring and threads on fitting with clean oil
- Looking at fitting from end with nut/washer/O-ring assembly, turn nut clockwise as far as possible
- Using wrench, turn (1) Valve to Hose Fitting into valve port marked “OUT” until washer touches control valve. Continue turning until washer touches thread nearest wrench pad
- Back off fitting counterclockwise not exceeding one revolution until it is oriented in the correct position
- Place wrench on the wrench pad of fitting to prevent fitting from turning and torque nut to 70-87 ft.-lb.
- Repeat installation process for second Valve to Hose Fitting into valve port marked “IN”.

Tools Needed

- 1 1/4” Wrench
- 1 1/16” Wrench
- OR
- Crescent Wrench (2 Needed)
- Torque Wrench

Fittings Needed from Parts Bag:

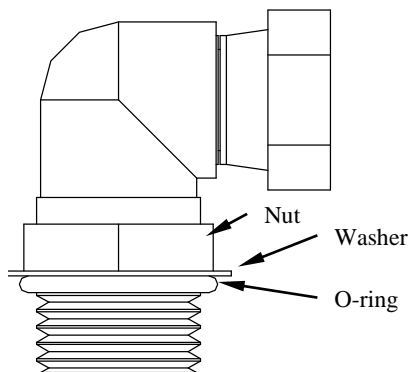

Part # 778831
Valve to Hose Fitting
Qty: 2

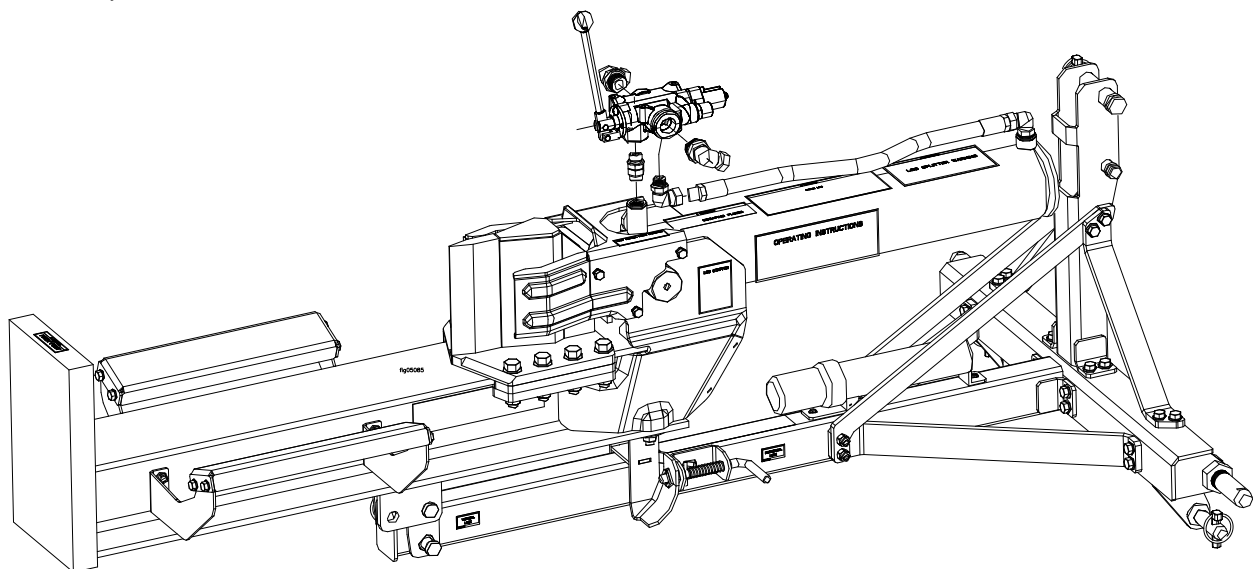
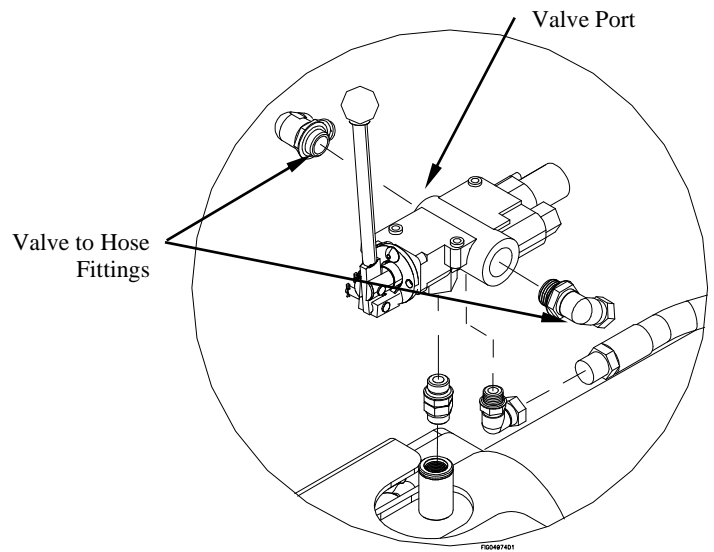

Assembly Instructions

Step 17 – Tractor Hoses

- Route high pressures hoses from tractor to Valve to Hose Fittings as shown below.
- Screw finger-tight high pressure hoses to Valve to Hose Fittings.
- Wrench tighten 1.5-3.0 Turns Past Finger Tight
- Connect remaining ends of high pressure hoses to tractor.

Tools Needed

- Crescent Wrench (2 needed)

Hoses Supplied by Customer:

Horizontal:

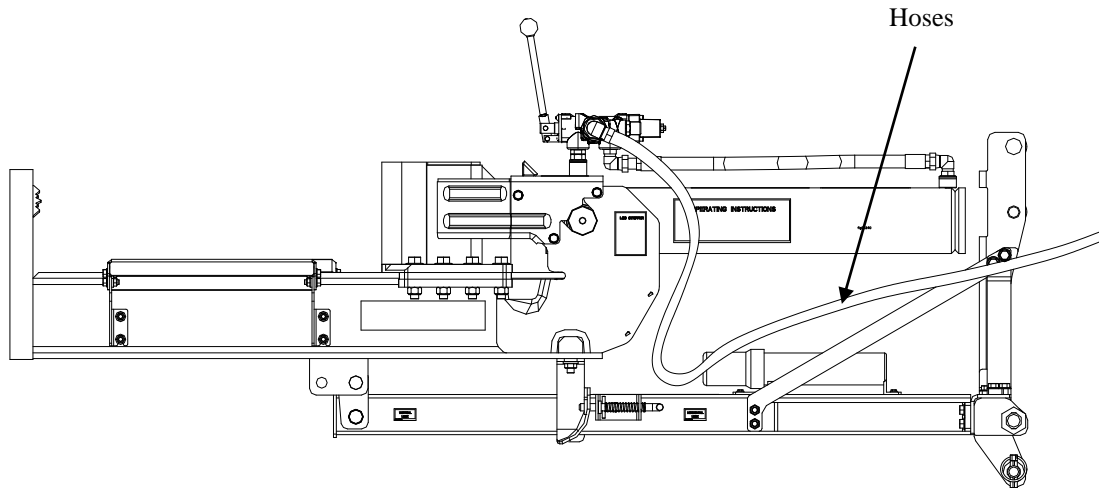

Vertical:

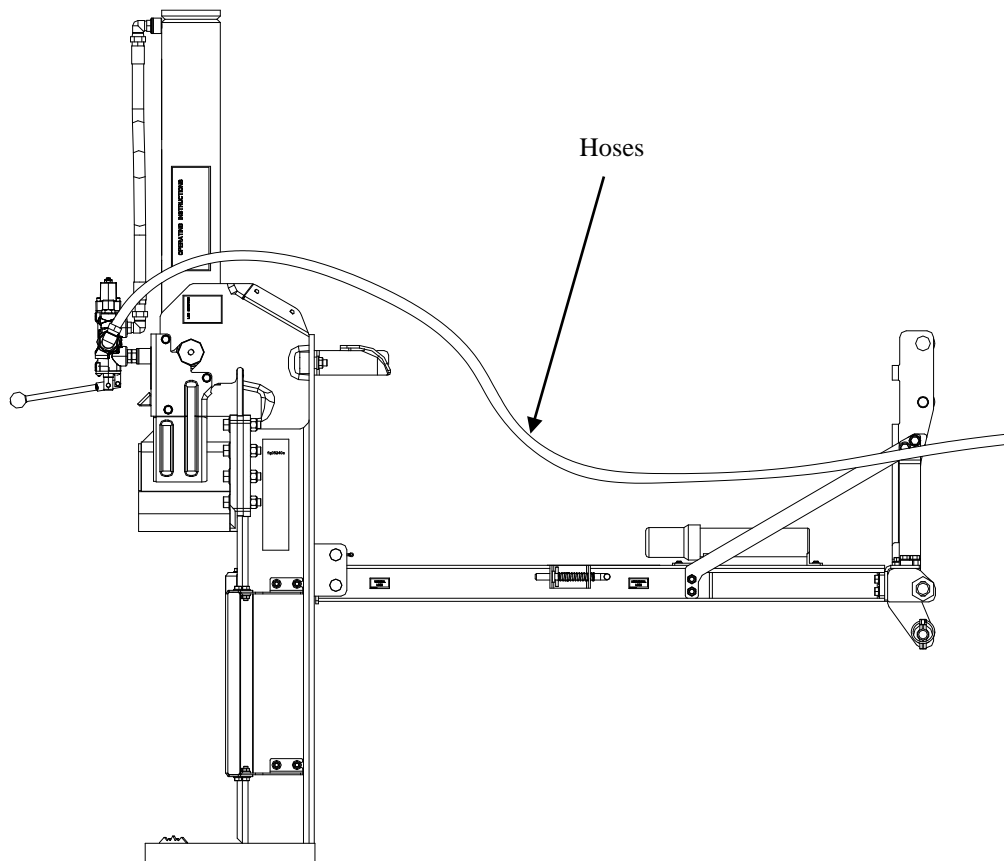

Limited Warranty

Dear Valued Customer:

The Powerhorse Product you just purchased is built with the finest material and craftsmanship. Use this product properly and enjoy the benefits from its high performance. By purchasing a Powerhorse product, you show a desire for quality and durability. Like all mechanical equipment this unit requires a due amount of care. Treat this unit like the high quality piece of machinery it is. Neglect and improper handling may impair its performance. Please thoroughly read the instructions and understand the operation before using your product. Always contact Powerhorse Product Support at 1-866-443-2576 prior to having any service or warranty work performed, as some services performed by parties other than Powerhorse approved service centers may void this warranty. This warranty is in lieu of any other warranty expressed or implied and Powerhorse assumes no other responsibility or liability outside that expressed within this warranty.

Limited Warranty

Powerhorse shall warrant any piece of equipment manufactured, or parts of equipment manufactured, to be free from defects in material or workmanship for a period of:

Powerhorse Warranty		
Item #	Consumer Warranty Period	Commercial Warranty Period
11965	3 years from date of purchase by user	N/A

“Consumer use” means personal residential household use by a consumer. “Commercial use” means all other uses, including use for commercial, income producing or rental purposes or when purchased by a business.

This warranty applies to the original purchaser of the equipment (verification of purchase, in the form of a receipt, is the responsibility of the buyer), is non-transferable, and covers parts and labor. Parts will be replaced or repaired at no charge, except when the equipment has failed due to lack of proper maintenance. If a part is no longer available, the part may be replaced with a similar part of equal function. Any misuse, abuse, alteration or improper installation or operations will void warranty. Determining whether a part is to be replaced or repaired is the sole decision of Powerhorse. Powerhorse will not provide for replacement of complete products due to defective parts. Any costs incurred due to replacement or repair of items outside of a Powerhorse approved facility is the responsibility of the buyer and not covered under warranty. Transportation costs to and from service center is the responsibility of the customer.

In addition to the normal warranty, Powerhorse shall warrant any normal wear item from defects in material or workmanship for a period of 90 days from the date of purchase by user. Normal wear items include, but are not limited to, filter elements.

This warranty specifically excludes the following; failure of parts due to damage caused by accident, fire, flood, windstorm, acts of God, applications not approved by Powerhorse in writing, corrosion caused by chemicals, use of replacement parts which do not conform to manufacturer’s specifications, damage related to rodent and/or insect infestation and damage caused by vandalism. Additional exclusions: loss of running time, inconvenience, loss of income, or loss of use, including any implied warranty of merchantability of fitness for a specific use. Also, Outdoor Power Equipment needs periodic parts and service to perform well, and this warranty does not cover instances when normal use has exhausted the life of a component or the engine.

This warranty does not cover any personal injury or damage to surrounding property caused by failure of any part. Repair or replacement of parts does not extend the warranty period.

The engine warranty is covered under the same terms and conditions as outlined above. Normal engine maintenance such as spark plugs, air filters, adjustments, fuel system cleaning and obstruction due to build up is not covered by this Powerhorse warranty.

Please fill in the following information and have it on hand when you call in on a warranty claim.

Customer Number: _____

Date of Purchase: _____

Powerhorse Serial Number: _____

Item Number: _____

▲WARNING: This product can expose you to soots, tars, and mineral oils (untreated and mildly treated oils and used engine oils), which are known to the State of California to cause cancer.

For more information go to www.P65Warnings.ca.gov.



POWERHORSE®

Manufactured by
Northern Tool + Equipment Co.,
2800 Southcross Drive West
P.O. Box 1499 Burnsville, MN 55337-0499