



POWERHORSE®

Owner's Manual

M1169H

ITEM NUMBER: 1169

SERIAL NUMBER: _____

Instructions for Assembly, Testing, Operation, Servicing, & Storage

Log Splitter: Outdoor hydraulic powered machine that splits wood logs.

WARNING

READ and UNDERSTAND this manual completely before using log splitter.

All operators of this equipment must read and completely understand all safety information, operating instructions, maintenance and storage instructions. Failure to properly operate and maintain the log splitter could result in serious injury to the operator and bystanders from moving parts that can crush or cut, flying objects, burns, fire or explosion, escaping high pressure hydraulic fluid, or carbon monoxide poisoning in particular, be aware of the following hazards.

Crush and Cut Hazards

Moving parts can crush and cut hands and fingers. Keep hands clear of end plate, wedge, logs, and log strippers while splitting.

High Pressure Hydraulic Fluid Hazards

High fluid pressures and temperatures are developed in hydraulic log splitters. Hydraulic fluid escaping through even a pin-size hole opening can puncture skin and cause severe blood poisoning. Inspect hydraulic system regularly for possible leaks. Never check for leaks with your hand while the system is pressurized. Seek medical attention immediately if injured by escaping fluid.

Fire Hazards

- If your log splitter is intended for use near an ignitable forest, brush, or grassy covered land, the engine exhaust should be equipped with a spark arrestor. See the "Specifications" section of this manual to determine if your splitter already has a spark arrestor. If not equipped, call Powerhorse Product Support for ordering information.
- Keep a fire extinguisher rated "ABC" nearby.

STOP!

ADD OIL TO ENGINE BEFORE USING: Engine is shipped without oil. DO NOT start log splitter without first adding oil.

ADD HYDRAULIC OIL: Your log splitter was shipped without hydraulic oil. Refer to Periodic Maintenance section of this manual for instructions on filling the hydraulic reservoir

INSPECT COMPONENTS: Closely inspect to make sure no components are missing or damaged.

See Initial Unpacking & Set-up for instructions and for whom to contact to report missing or damaged parts.

Prime the Pump: The pump on your log splitter needs to be primed before use. Refer to initial setup for instructions.

Any Questions, Comments, Problems or Parts Orders
Call Powerhorse Product Support 1-866-443-2576

Hazard Signal Word Definitions





	<p>This is the safety alert symbol. It is used to alert you to potential personal injury hazards. Obey all safety messages that follow this symbol to avoid possible injury or death.</p>
	<p>DANGER (red) indicates an imminently hazardous situation which, if not avoided, will result in death or serious injury.</p>
	<p>WARNING (orange) indicates a potentially hazardous situation which, if not avoided, could result in death or serious injury.</p>
	<p>CAUTION (yellow) indicates a potentially hazardous situation which, if not avoided, may result in minor or moderate injury.</p>
	<p>CAUTION (yellow) used without the safety alert symbol indicates a potentially hazardous situation which, if not avoided, may result in property damage.</p>

fig01453

Table of Contents

Hazard Signal Word Definitions	2
Table of Contents.....	3
About Your Log Splitter.....	4
Safety Label Locations	5
Machine Component Identification	7
Initial Set-up	8
Moving and Towing to the Job Site	10
Before Each Use-Inspection/Maintenance	13
Before Each Use - Fueling	15
Before Each Use – Work Site Selection and Setup.....	16
Splitting Operation	17
Storage.....	23
Periodic Maintenance	24
Troubleshooting.....	25
Specifications	26
Parts Breakdown – Exploded View 1169	27
Summary of Important Safety Information for Operation.....	30
Assembly Instructions.....	35
798736 Engine Exploded View	65
798736 Engine Parts List.....	66
798736 Engine Kits	67
Engine	68
Limited Warranty.....	74

About Your Log Splitter

Thank you for purchasing your Powerhorse log splitter!

About Your Log Splitter:

This log splitter is a machine designed to split wood logs using a hydraulically powered moving wedge. The log splitter's gasoline engine is used to pressurize the hydraulic system.

This log splitter is designed to split logs *lengthwise with the grain only*.

This log splitter model is capable of splitting logs up to 25" long and 14" in diameter.

Your splitter can be used in either a vertical or horizontal splitting position:

- When the splitter is set up to operate in the horizontal splitting position, a log is placed on the horizontal beam and the wedge moves horizontally into the end of the log to split it.
- When the splitter is set up to operate in the vertical splitting position, the log is placed on the end plate, upright on its end, and the wedge moves down into the top of the log to split it.

The horizontal splitting position is used for lighter logs that can be easily loaded onto the beam. The vertical splitting position is used for heavier logs that are difficult to load onto the beam.

The technical specifications for your log splitter are provided in the Specifications section of this manual.

WARNING

This log splitter uses a high-pressure hydraulic system to generate a very strong splitting force.

Read the manual completely before using the machine to understand how to safely operate and maintain it.

Follow all safety precautions presented throughout this manual. A summary of important safety information can be found at the end of this manual.

Contact Powerhorse Product Support at 1-866-443-2576 for any questions about the appropriate use of this log splitter and/or optional accessories.

Warranty Registration:

Please fill in the warranty registration information in the back of this manual and have it on hand when you call in on a warranty claim or replacement parts.

Attention: All Rental Companies and Private Owners who loan this equipment to others!

All persons to whom you rent/loan the log splitter must have access to and read this manual. Keep this owner's manual with the splitter at all times and advise all persons who will operate the machine to read it. You must provide instruction on how to safely operate the splitter and remain available to answer any questions a renter/borrower might have.

Safety Label Locations

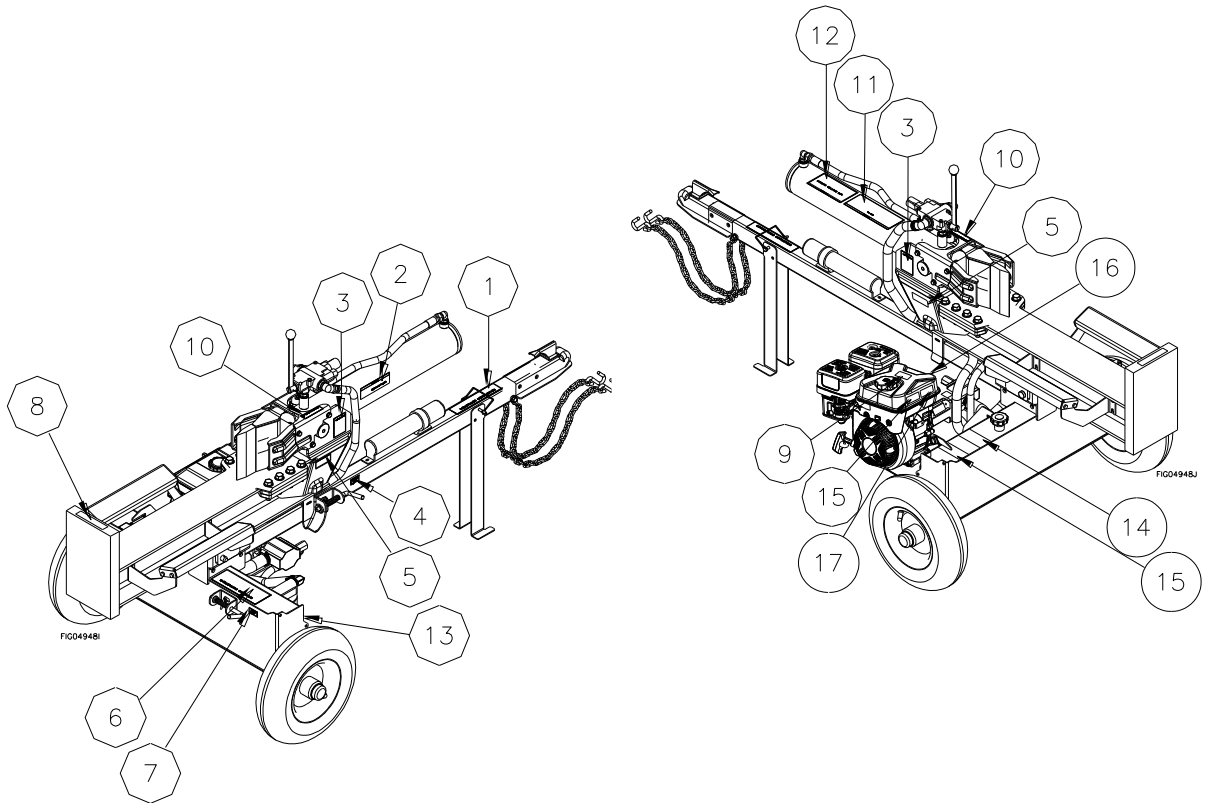

Reference #	Part Number	Description	Qty
1	791105	Decal, Moving/Towing Instructions	1
2	777891	Decal, Escaping Fluid	1
3	778717	Decal, Log Stripper	2
4	778597	Decal, Horizontal Lock	1
5	777890	Decal, Fire Hazard Warning	2
6	777887	Decal, Operation Instructions	1
7	778714	Decal, Vertical Lock	1
8	787944	Decal, Pinch Point	1
9	790852	Decal, Burn Hazard Warning	1
10	778609	Decal, Split Control	1
11	778610	Decal, Log Splitter Warning	1
12	777889	Decal, Stuck Log	1
13	791123	Decal, 45 mph	1
14	788937	Decal, Poisonous Gas	1
15	788935	Decal, Fuel Fire, Explosion Hazard	2
16	795124	Decal, E85 Caution	1
17	795346	Decal, Poisonous Gas (Engine Tank)	1

Always make sure safety labels are in good condition. If a safety label is missing or not legible, order new labels or unsafe operation could result. Contact Powerhorse Product Support at 1-866-443-2576.

Safety Label Locations

1 MOVING/TOWING INSTRUCTIONS

Moving log splitter by hand:

- Lock beam in horizontal position (tip-up models only).
- Lock towbar leg or jack stand in DOWN position.
- Lock support leg in UP position (if equipped).
- Do not attempt to move log splitter up or down slope by hand.

Towing log splitter:

- Latch coupler securely to class 2 or higher hitch with 2" ball.
- Lock towbar leg/jack stand or support leg (if equipped) in the UP position.
- Attach safety chains to tow vehicle.
- Close fuel shut-off valve on engine (if equipped).
- Do not tow faster than 45 mph. Higher speeds can cause loss of control.
- Check local, state, and federal requirements before towing on public roads.

PN 751102

10 SPLIT CONTROL LEVER OPERATION

Split Log Neutral Return

2 WARNING

ESCAPING HIGH PRESSURE HYDRAULIC FLUID HAZARD

High fluid pressures and temperatures are developed in the hydraulic system. Hydraulic fluid escaping through even a pin-size hole opening can puncture skin and cause blood poisoning.

- Inspect hydraulic system regularly for leaks.
- Never check for leaks with your hand while system is pressurized.
- Seek medical attention immediately if injured by escaping fluid.

PN 770202

11 WARNING

Moving parts can crush and cut. Pieces can fly out while splitting. Follow safety rules for operating the log splitter or serious injury could result.

- READ the Owner's Manual completely before operating.
- Only one person should operate the log splitter. If an assistant is helping to load logs, the operator should not actuate controls until the assistant is at least 10 ft away.
- Stay in the designated OPERATOR POSITION while actuating the controls.
- Split wood in direction of the grain only.
- Hold bark side of logs when loading.
- Keep hands away from wedge, endplate/ram, and partly split logs.
- Never leave log splitter unattended during operation.
- Stay off slopes and slippery surfaces.

See additional safety rules in the Owner's Manual.

PN 770202

3 LOG STRIPPER

RETRACT WEDGE TO REMOVE STUCK WOOD

WARNING

PINCH POINT

Keep hands clear of wedge and log stripper

778717

4 HORIZONTAL LOCK

PN 778597

12 WARNING

IF LOG BECOMES STUCK ON WEDGE

A log can become stuck to the wedge if the wedge becomes embedded in the log and the log doesn't split and separate. This can happen if the log is too stringy or tough to split completely.

A stuck log will move back with the wedge on the initial attempt to retract the wedge. If this happens, STOP retracting the wedge immediately and follow the directions below. NEVER attempt to remove a stuck log by:

- Using the hydraulic force of the splitter
- Modifying the splitter
- Adding attachments to the splitter

Personal injury could result from log or metal pieces flying out at high speed toward the operator or bystanders, or the splitter could become damaged.

PN 770202

ALWAYS remove the log MANUALLY using the following procedure:

1. If there is already 1" or more of clearance between the log and endplate, go to step 2. Otherwise, retract wedge just enough to remove pressure between the log and endplate - about 1" clearance.
2. Turn engine OFF.
3. Remove stuck log from the wedge manually with a pry bar or sledgehammer. Important: Be extremely careful as log pieces may fly off as they separate from the wedge. Wear safety goggles and make sure bystanders are clear.
4. Do not attempt to respit a stuck log once it has been removed from the wedge.

PN 770202

5 WARNING

FIRE HAZARD

Hot exhaust can ignite dry brush, trees, or grass.

- Equip engine with a spark arrestor if you will be using near ignitable forest, brush or grassy covered land.
- Keep a fire extinguisher on hand that is rated for ordinary combustibles & flammable liquids.

PN 770202

13 MAX TOWING SPEED

45 MPH

6 OPERATING INSTRUCTIONS

GENERAL

- Stay in the OPERATOR POSITION while actuating controls.
- Never actuate controls until the helper is 10ft away from log splitter, including any helpers assisting to load logs.
- Wear eye protection, hearing protection, snug fitting gloves, and safety shoes or heavy boots. No loose or dangling apparel.

SETTING UP

- Place log splitter on dry, level ground.
- Secure splitter for unintended movement.
- Place splitter in horizontal or vertical position.
- Start engine

SPLITTING LOG

- Position log on beam, against endplate.
- Move split control to extend wedge and split log.
- Release split control to stop wedge.
- Move split control to return wedge.
- Remove split wood from work area.

Operator Position - horizontal Operator Position - vertical

PN 770202

14 WARNING

Poisonous Gas

This product gives off carbon monoxide, a poisonous gas that can kill you. You CANNOT smell it, see it, or taste it.

- ONLY use outside & far away from windows, doors, & vents.
- NEVER use inside homes, garages, or sheds. EVEN if you run a fan or open doors or windows. See owner's manual for more details.

7 VERTICAL LOCK

PN 778714

8 WARNING

PINCH POINT

Keep hands clear during operation.

787944

15 WARNING

Fuel Fire/Explosion Hazard

Fuel is flammable and explosive.

- Never fuel a running or hot engine.
- Clean up fuel spills immediately.
- Ensure there are no fuel leaks before starting.
- Keep sources of sparks and flames away.
- Hot exhaust may also ignite spilled fuel.
- No Smoking.
- Keep a fire extinguisher nearby.

9 WARNING

Burn Hazard

Do not touch hot muffler. Muffler may be hot even if the unit is stopped.

Allow unit to cool before servicing.

787944

16 CAUTION

E0 E10 E15 E85

DO NOT USE FUEL CONTAINING MORE THAN 10% ETHANOL; IT IS A VIOLATION OF U.S. FEDERAL LAW, WILL DAMAGE YOUR PRODUCT AND VOID THE WARRANTY.

17 WARNING

Poisonous Gas

This product gives off carbon monoxide, a poisonous gas that can kill you. You CANNOT smell it, see it, or taste it.

- ONLY use outside & far away from windows, doors, & vents.
- NEVER use inside homes, garages, or sheds. EVEN if you run a fan or open doors or windows. See owner's manual for more details.

Machine Component Identification

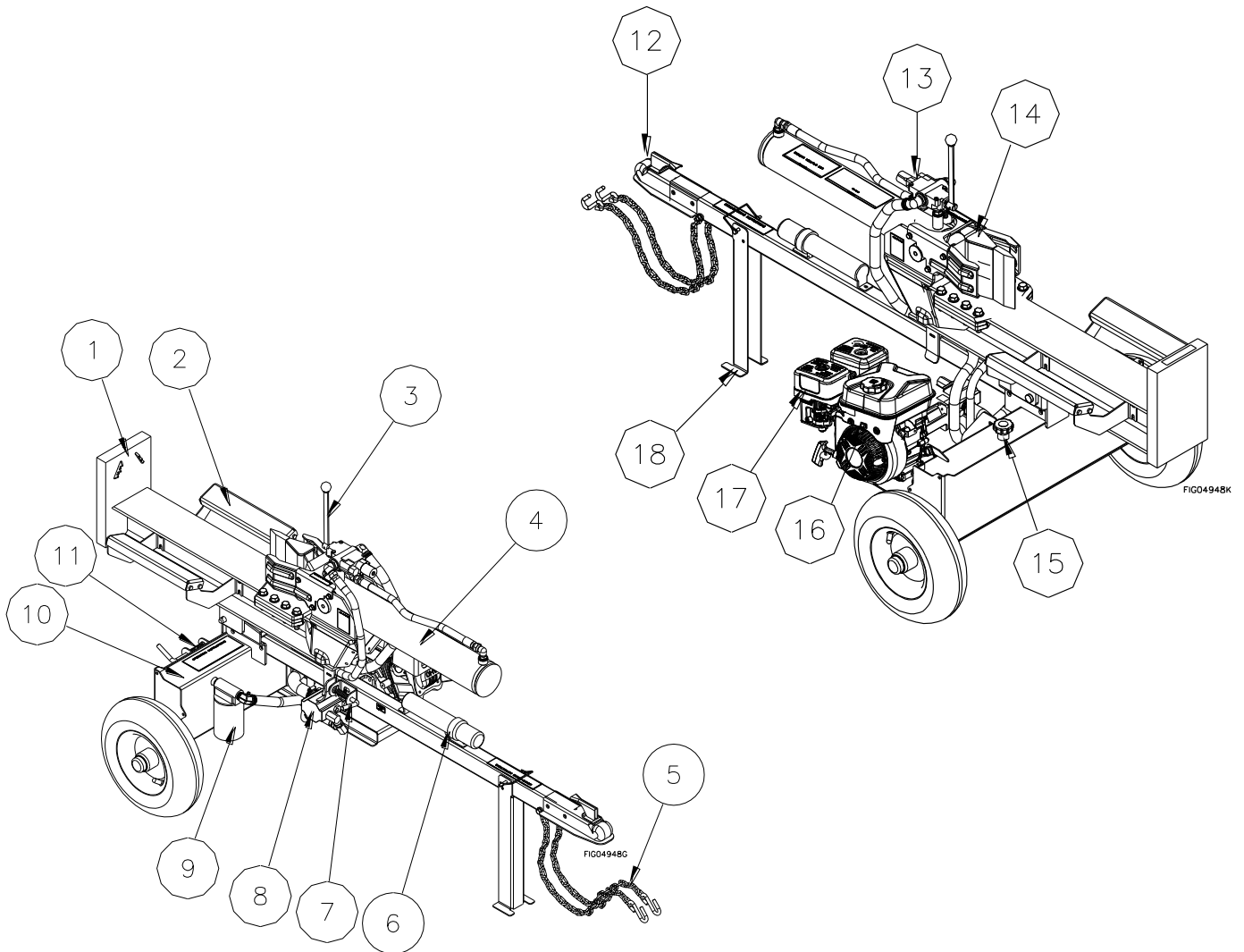

Ref	Description
1	End Plate
2	Log Cradles
3	Split Control Lever
4	Cylinder
5	Safety Chains
6	Manual Tube
7	Horizontal Lock
8	Hydraulic Pump
9	Return Line Filter

Ref	Description
10	Axle/Hydraulic Tank
11	Vertical Lock
12	2" Ball Coupler
13	Control Valve
14	Wedge
15	Hydraulic Breather/Dipstick
16	Engine On/Off Switch
17	Engine
18	Support Leg

Initial Set-up

IMPORTANT!

Engine is shipped without oil. DO NOT start the engine before adding oil.

See Assembly Instructions section of this manual to assemble the log splitter before setup.

Step One:

Inspect Log Splitter Components.

Closely inspect all log splitter components.

(See Machine Components section of this manual for diagram of components.)

- If you have missing or damaged components, please contact Product Support at 1-866-443-2576.

Step Two:

Add Oil to Engine

Step Three:

Add Hydraulic Oil to Reservoir and Prime the Pump

Add oil to the engine. Using a funnel, add SAE 10W-30 oil up to the FULL mark on the dipstick. (See engine Owner's Manual for oil capacity and location of fill cap.)

⚠ WARNING: High fluid pressures and temperatures are developed in hydraulic log splitters. Hydraulic fluid escaping through a pinhole sized opening can burn or puncture skin, resulting in wounds that could cause blood poisoning, infection, disability, gangrene, amputation, or death. Therefore, the following instructions should be heeded at all times when inspecting or servicing the hydraulic components of the log splitter.

- NEVER check for leaks with your hand. Leaks can be located by holding a piece of cardboard or wood (at least two feet long) with your hand at one end and passing the other end over the suspected area (wear eye protection). Look for discoloration of the cardboard or wood.
- NEVER adjust the pressure of the pump or valve.
- If injured by escaping fluid, no matter how small the wound is, see a doctor at once. A typical injection injury may be a small wound that does not look serious. However, severe infection or reaction can result if proper medical treatment is not administered immediately by a doctor who is familiar with injection injuries.

1. Remove hydraulic oil dipstick.
2. Refer to the **Specifications** section for approximate hydraulic oil capacity.
3. Fill reservoir with 10 wt. AW32, ASLE H-150, or ISO 32 oil. Use a funnel
4. Replace hydraulic oil dipstick and check that oil level reads full. Note: Do not thread in dipstick when checking oil level.
5. Disconnect the spark plug wire from the spark plug
6. Pull on the starter grip recoil at least 20 times so that hydraulic fluid has cycled through the pump
7. Reconnect the spark plug wire to the spark plug
8. Start engine and use control valve handle to extend and retract wedge 5 (five) times to remove air from the high pressure lines.
9. With wedge retracted, check oil level again.

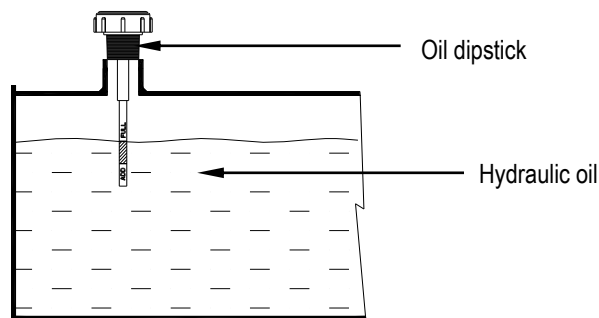

Initial Set-up

10. Replace hydraulic oil fill/vent cap.
11. Start engine and use control valve handle to extend and retract wedge five (5) times to remove air from the high-pressure lines.
12. With wedge retracted, check oil level again. Fill if necessary.

⚠ WARNING: NEVER remove the hydraulic oil dipstick when the engine is running or hot. Hot oil can escape causing severe burns. Allow log splitter to cool completely before removing hydraulic oil dipstick.

Note: If the log splitter will be run for long periods of time in outdoor temperatures above 70°F, we recommend changing the hydraulic oil to DEXRON III.

Step Four: Lubricate Beam

Apply grease to beam. This will help prevent wear between the wedge and beam.

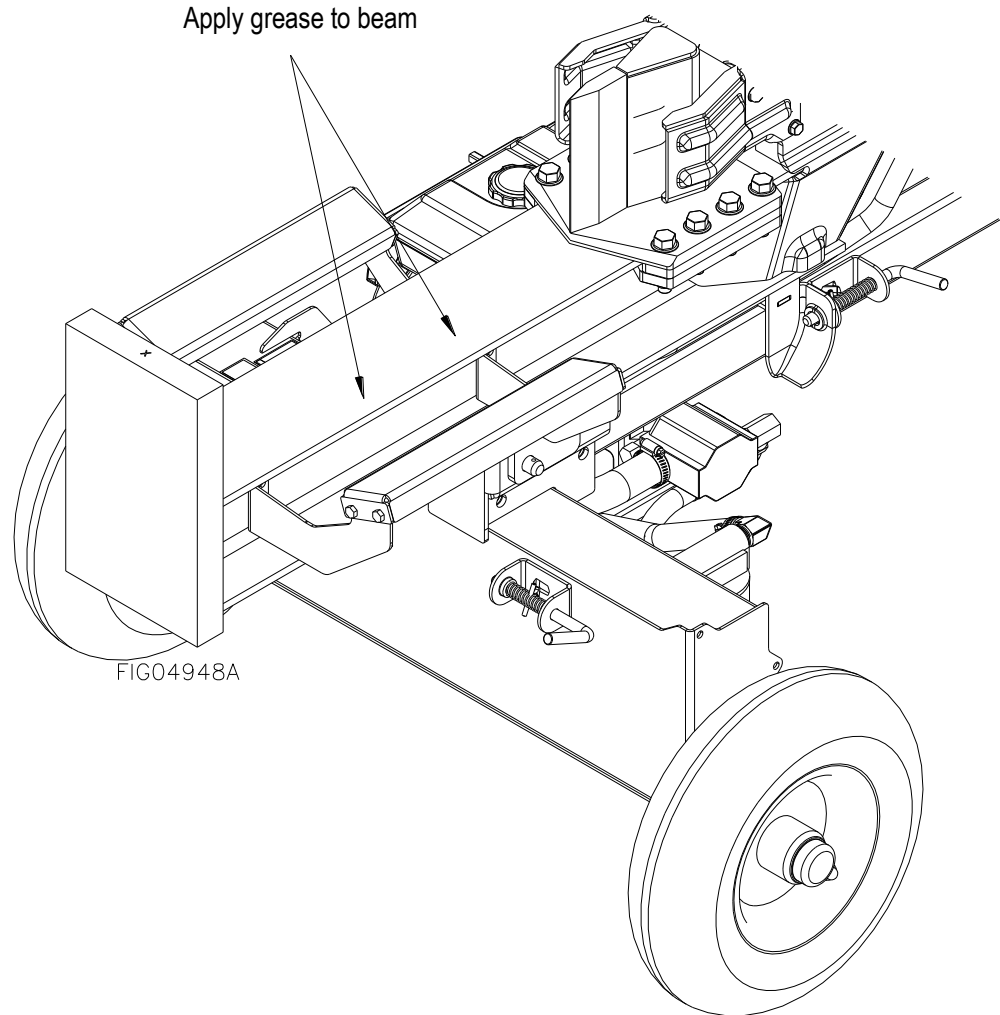

Moving and Towing to the Job Site



WARNING

The log splitter is heavy. It can crush and cause serious injury if it rolls out of control or tips over. Follow the instructions below for safely moving and towing the log splitter.

Moving the log splitter:

<p>1. Place in Horizontal position</p>	<p>Make sure the log splitter is locked in the horizontal position with latch rod before moving.</p> <p>NEVER move log splitter when it is in vertical configuration because it will be unstable and could tip.</p>
<p>2. Engine off.</p>	<p>IMPORTANT: Make sure log splitter engine is off.</p> <p>Never move the log splitter with its engine running.</p>
<p>3. Fuel valve off (if equipped)</p>	<p>Turn fuel valve off to prevent carburetor flooding and reduce the chance of fuel leakage. Refer to Engine owner's manual for fuel valve location.</p>
<p>4. Lock: Support leg DOWN</p>	<p>Lock the support leg in the "DOWN" position before you move the log splitter.</p> <div data-bbox="495 877 1421 1402" data-label="Image"> </div>
<p>5. Move log splitter to work site or tow hitch</p>	<p>Move log splitter by hand either directly to chosen work site or to vehicle hitch for towing. (See Before Each Use: Step Three: instructions on selecting a work site)</p> <p><u>Important Safety Instructions:</u></p> <ul style="list-style-type: none"> • Hills. Do not move the log splitter up or down hills by hand - use a towing vehicle. • No riding. Never allow anyone to sit or ride on the log splitter. • No cargo. Never transport cargo or wood on the log splitter.

Moving and Towing to the Job Site

Towing:

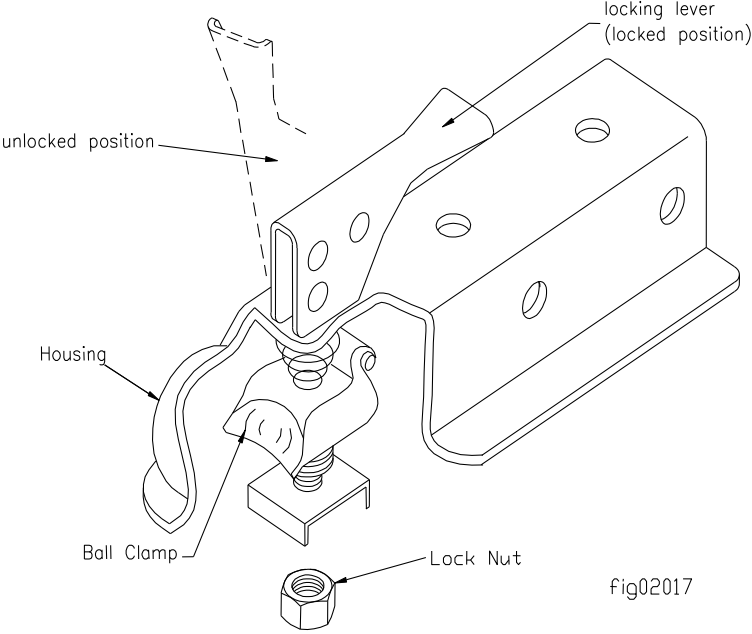
1. Read instructions	Review towing safety instructions in your vehicle manual.
2. Check tires	<p>Make sure tires are fully inflated and in good repair.</p> <p>⚠️ WARNING:</p> <ul style="list-style-type: none"> • Do not over-inflate tires. Serious injury can occur if tire explodes. • When seating a bead after repair, do not exceed 30 PSI. Pressures higher than 30 PSI can cause the tire and wheel to rupture and explode.
3. Attach to hitch (2" ball)	<p>Attach log splitter to vehicle hitch</p> <ol style="list-style-type: none"> 1. Attach log splitter's coupler to a class 2 or higher hitch with 2" ball (only). 2. Adjust coupler to ball by raising locking lever and turning lock nut with fingers. 3. Proper adjustment is obtained when coupler is as tight as possible on ball and locking lever can still be opened and closed. 4. Lock lever closed to secure the attachment. An optional locking pin or padlock may be inserted in the locking lever hole for extra security. 
4. Attach safety chains	<p>Attach safety chains.</p> <ol style="list-style-type: none"> 1. Two safety chains must be used while towing. 2. Cross safety chains under the coupler, allowing only enough slack for vehicle turns.

Moving and Towing to the Job Site

5. Put support leg UP

Move the support leg to the “UP” position and lock.

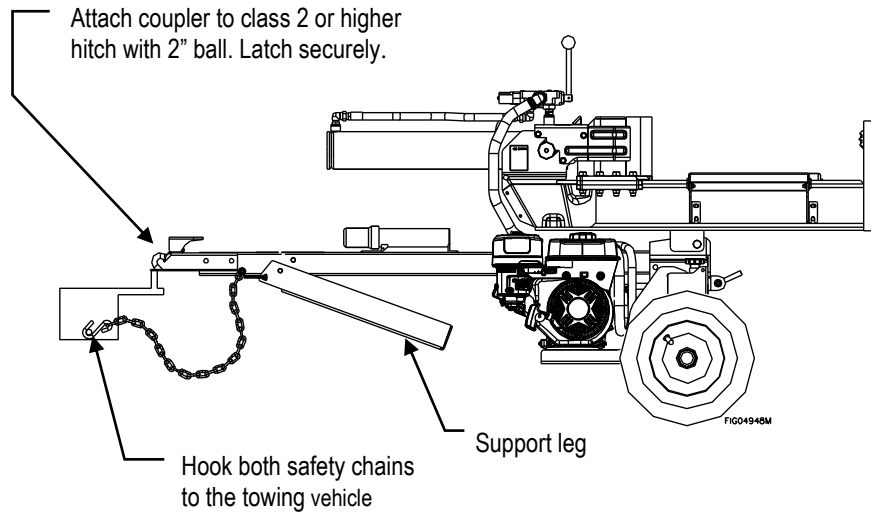

6. Tow to desired location

Tow log splitter carefully to desired work site.

(See Before Each Use section on selecting an appropriate work site)

Important safety instructions:

- **Added length.** Be aware of the added length of the splitter.
- **Speed limit.** Never tow this log splitter over 45 mph. Faster speeds may result in loss of control.
- **Rough terrain.** Drive slowly and take extra caution when traveling over rough terrain.
- **On public roads.** If towing on a public road, make sure to comply with all local, state, and federal towing requirements. It is the sole responsibility of the purchaser to obtain licensing, trailer lights, safety chains or signage as needed to comply.
- **Unattended.** Turn off the towing vehicle before leaving the splitter unattended.
- **Under the influence.** Never tow or operate this splitter while under the influence of alcohol, drugs, or medication.

7. Lock support leg down & unhitch

Lock support leg in the DOWN position and disconnect from vehicle.

NEVER operate log splitter while it is attached to the vehicle.

Before Each Use-Inspection/Maintenance

Step One: Inspect and maintain log splitter before each use

If the log splitter has been used previously, it must be inspected and maintained BEFORE EACH SUBSEQUENT USE.

WARNING

ALWAYS shut off the engine, disconnect the spark plug, and relieve system pressure before inspecting, cleaning, adjusting, or repairing the splitter. Relieve system pressure by moving Split Control Lever back and forth several times.

IMPORTANT:

If a part needs replacement, only use parts that meet the manufacturer's specifications. Replacement parts that do not meet specifications may result in a safety hazard or poor operation of the log splitter.

1. Engine off / relieve pressure	<p>Perform all inspections/repairs with the engine off and hydraulic system pressure relieved.</p> <ol style="list-style-type: none"> 1. Make sure engine is off and cool. 2. Disconnect the spark plug 3. Relieve all hydraulic system pressure by moving the Split Control Lever back and forth several times.
2. Remove debris	<p>Remove debris from engine, muffler, and moving parts.</p> <ol style="list-style-type: none"> 1. <u>Engine debris.</u> Debris on a hot engine can be a fire hazard. Clean debris and chaff from engine cylinder head, cylinder head fins, blower housing rotating screen, and muffler areas. Avoid contact with hot muffler. 2. <u>Other debris.</u> Debris on moving parts can cause excess wear. Clear debris from the slide beam, wedge, and endplate.
3. Fuel tank/lines	<p>Check fuel tank and fuel lines for leaks.</p> <p>Any fuel leak is a fire hazard. Fix any fuel leaks before starting engine.</p>
4. Mechanical parts	<p>Check to be sure that all nuts and bolts are tight to make sure the log splitter is in safe working condition.</p>
5. Hydraulic system	<p>Check the hydraulic system carefully:</p> <ol style="list-style-type: none"> 1. Visually inspect all hoses, tubing, clamps/fittings, pump, and cylinder for cracks, fraying, kinks, or other damage. 2. Check all components for oily residue, which may indicate a leak. <p>Do NOT operate the log splitter if there is any indication of damage or oily residue. Small leaks in hydraulic lines can cause severe injuries and can also be an indication of catastrophic failure in the near future. The life of hydraulic hoses may be from a few months to a few years, depending on use and storage patterns.</p> <p> WARNING: High fluid pressures and temperatures are developed in hydraulic log splitters. Hydraulic fluid escaping through a pin hole sized opening can burn or puncture skin, resulting in wounds that could cause blood poisoning, infection, disability, gangrene, amputation, or death. Therefore, the following instructions should be heeded at all times when inspecting or servicing the hydraulic components of the log splitter:</p>

Before Each Use-Inspection/Maintenance

- Stop the engine, disconnect the spark plug, and move all control valve handles back and forth to relieve pressure before changing or adjusting hydraulic system components such as hoses, tubing, fittings or other components.
- NEVER check for leaks with your hand. Leaks can be located by holding a piece of cardboard or wood (at least two feet long) with your hand at one end and passing the other end over the suspected area (wear eye protection). Look for discoloration of the cardboard or wood.
- NEVER adjust the pressure setting of the pump or valve.
- If injured by escaping fluid, no matter how small the wound is, see a doctor at once. A typical injection injury may be a small puncture wound that does not look serious. However, severe infection or reaction can result if proper medical treatment is not administered immediately by a doctor who is familiar with injection injuries.

6. Hydraulic oil level

Check the hydraulic oil level. Fill as needed. Note: Do not thread in the oil dipstick when checking hydraulic oil level.

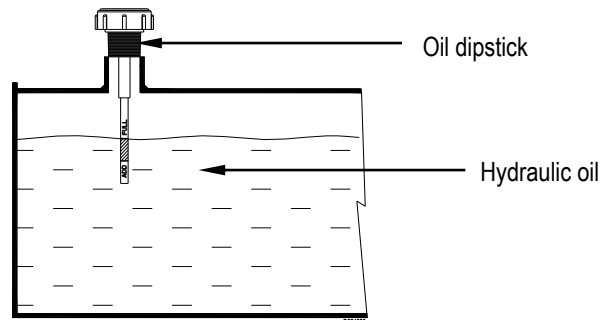

⚠ WARNING: NEVER remove the hydraulic oil dipstick when the engine is running or hot. Hot oil can escape causing severe burns. Allow log splitter to cool completely before removing hydraulic dipstick.

7. Engine

Inspect and perform engine maintenance as directed in the engine section of this manual.

8. Spark arrestor muffler

If the engine is equipped with a spark arrestor muffler, clean and inspect it regularly (follow spark arrestor service instructions found in the engine section of this manual).

Replace if damaged.

9. Tires

Make sure tires are fully inflated and in good repair if you will be towing the splitter.

See tire sidewall for recommended tire pressure.

⚠ WARNING:

- Do not over-inflate tires. Serious injury can occur if tire explodes.
- When seating a bead after repair, do not exceed 30 PSI. Pressures higher than 30 PSI can cause the tire and wheel to rupture and explode.

10. Shields/guards

Replace all guards and shields after servicing the log splitter.

Before Each Use - Fueling

Step Two: Fueling

⚠️ WARNING

Gasoline is highly flammable and explosive. You can be burned or seriously injured when handling fuel. Use extreme care when handling gasoline.

1. Engine off/cool	<p>The engine must be off and allowed to cool at least two minutes before adding fuel.</p> <p>⚠️ WARNING: A running engine is hot enough to ignite fuel. Never add fuel or remove gas cap if engine is running or still hot.</p>
2. Outdoor location	<p>Fill fuel tank outdoors – never indoors.</p> <p>⚠️ WARNING: Gasoline vapors can ignite if they collect inside an enclosure. Explosion can result.</p>
3. Remove gas cap	<p>Remove engine gas cap.</p>
4. Add gasoline	<p>Add gasoline through fill opening from a UL-listed container.</p> <p><u>Important Safety Instructions:</u></p> <ul style="list-style-type: none"> • Use approved container. NEVER pump fuel directly into engine at gas station. Static charge can build and ignite fuel. Use a UL listed fuel container to transfer gas to the engine. • Don't overfill. DO NOT overfill the gas tank. Allow at least 1/2" of empty space below the fill neck to allow for fuel expansion • Heat/flames/sparks. Stay away from sources of heat, flame, or sparks while adding fuel. <div style="text-align: center; margin-top: 20px;">  <p>CAUTION</p> <p>E0 E10 E15 E85</p> <p>DO NOT USE FUEL CONTAINING MORE THAN 10% ETHANOL; IT IS A VIOLATION OF U.S. FEDERAL LAW, WILL DAMAGE YOUR PRODUCT AND VOID THE WARRANTY.</p> </div>
5. Spills/splashes	<p>Clean up fuel spills /splashes immediately.</p> <ol style="list-style-type: none"> 1. Move the log splitter away from spilled fuel on the ground. 2. Wipe fuel off engine and wait 5 minutes for excess fuel to evaporate before starting engine. 3. Gas soaked rags are flammable and should be disposed of properly. 4. If gasoline is spilled on your skin or clothes, change clothes and wash skin immediately.
6. Replace gas cap	<p>Replace gas cap securely before starting engine.</p>
7. Gasoline storage	<p>Store extra gasoline in a cool, dry place in a UL listed, tightly sealed container.</p>

Before Each Use – Work Site Selection and Setup

Step Three: Work site selection and log splitter setup

⚠ WARNING

It is important to select an appropriate work site and properly set up the log splitter in order to minimize the risk of slips and falls, equipment rolling or tipping over, carbon monoxide poisoning, and accidental fires.

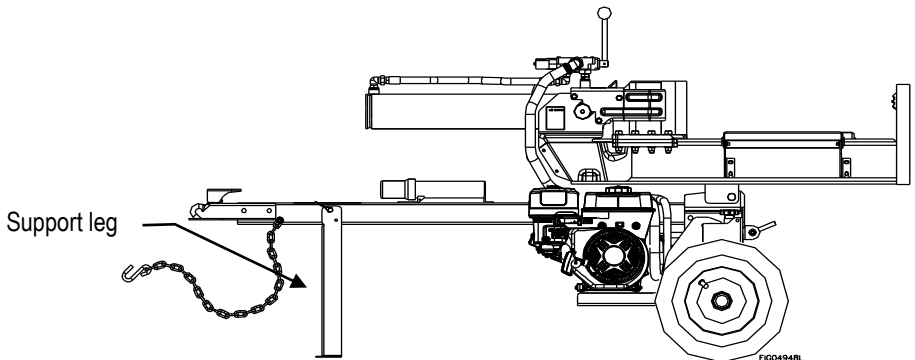
1. Select location	<p>Select an appropriate location for operating the log splitter.</p> <p><u>Requirements:</u></p> <ol style="list-style-type: none"> 1. Dry, with a level surface with good footing. Stay clear of areas with mud, ice, tall grass, weeds, brush, or snow. 2. Outdoors, away from air intakes. <p>⚠ WARNING: The running engine gives off carbon monoxide, a poisonous gas that can kill you. You CANNOT smell it, see it, or taste it.</p> <ul style="list-style-type: none"> • ONLY run log splitter <u>OUTDOORS</u> and away from air intakes. NEVER run log splitter inside homes, garages, sheds, or other buildings or semi-enclosed spaces. These spaces can trap poisonous gases, EVEN if you run a fan or open windows. • If you start to feel sick, dizzy, or weak while using the log splitter, shut off the engine and get to fresh air RIGHT AWAY. See a doctor. You may have carbon monoxide poisoning.
2. Fire precautions	<p>Take the following precautions against fire:</p> <ol style="list-style-type: none"> 1. <u>IMPORTANT:</u> If your splitter will be used near any unimproved forest, brush, or grassy covered land, <i>then engine must be equipped with a <u>spark arrestor</u>.</i> <p>(See the “Specifications” section of this manual to determine if your splitter already has a spark arrestor. Contact Powerhorse Product Support at 1-866-443-2576 for information about obtaining a spark arrestor for your log splitter if it is unequipped.)</p> <ol style="list-style-type: none"> 2. Make sure you comply with applicable local, state and federal codes. 3. Keep a fire extinguisher available (rated “ABC”) as a precautionary measure when operating the log splitter in dry areas.
3. Position splitter 7’ from any combustibles or flammable liquids	<p>Position muffler at least 7 feet from combustible objects during operation.</p> <p>Hot exhaust fumes from engine could cause fire. Also, hydraulic oil leaking or spraying on hot engine can ignite.</p>
4. Lock support leg DOWN	<p>Lock the <u>support leg</u> in the “DOWN” position.</p> <div style="text-align: center;">  </div>
5. Block wheels	<p>Block the wheels to prevent unintended movement of the log splitter.</p>
6. Apply grease	<p>Apply grease to the beam.</p>

Splitting Operation



WARNING

Before starting this log splitter, review the following instructions and safety information for safe operation of the log splitter.

Failure to follow these rules may result in serious injury to the operator or bystanders from moving parts that crush, cut, or entangle from flying objects, burns, fire, falling or tripping, or from carbon monoxide poisoning.

General safety information:

- **Read manual.** Do not allow anyone to operate the log splitter who has not read the Owner's Manual or has not been instructed on the safe use of the splitter. The log splitter owner should instruct all operators in safe log splitter operation.
- **Age restrictions.** Never allow anyone under 16 years old to operate the log splitter. Anyone 16 years and older must be trained and supervised by a trained adult.
- **Intended use.** Log splitters should only be used for splitting wood logs, lengthwise with the grain. Do not use for other purposes as unforeseen hazards may result.
- **Modifications.** Never modify or alter the log splitter in any way. Modifications can create serious safety hazards and will void the warranty:
- **Attachments.** Never add attachments to the splitter, except for authorized accessories supplied by the manufacturer with instructions for safe installation and use.
- **Engine speed.** The maximum engine speed is preset at a safe limit. Never attempt to modify the engine speed setting to run at a higher speed.
- **Fuel/exhaust system.** NEVER modify or add to the exhaust system, fuel tanks, or fuel lines. Fire can result.
- **Remote control.** NEVER attach a rope, cable, or other remote device to the splitting control.
- **Splitting wedge.** NEVER attempt to change the height or speed of the splitting wedge.
- **Pressure setting.** NEVER increase the pressure setting of the pump or control valve.
- **Safety equipment/controls.** Always operate the log splitter with all safety equipment in place and in good working order, and all controls properly adjusted for safe operation.
- **Know how to stop.** Be thoroughly familiar with all controls and with the proper use of the equipment. Know how to stop the log splitter and relieve system pressures quickly if needed.
- **Operating speed.** Always operate the log splitter at the manufacturer's recommended speed. The maximum speed of the engine pump and wedge are preset within safe limits.
- **Daylight only.** Only use the log splitter in daylight so you can see what you are doing.
- **Smoking/sparks.** Never smoke while operating the log splitter, and never operate near sources of sparks or flames.
- **Under the influence.** Never operate, or let anyone else operate, the log splitter while under the influence of alcohol, drugs, or medication.
- **Unattended.** Never leave the machine unattended while the engine is running.
- **Refueling.** Never refuel the engine until it has cooled at least two minutes.
- **Adjusting/repairing.** Always make sure the engine is off before cleaning, repairing or adjusting the splitter, except as recommended by the manufacturer. In addition, disconnect the spark plug and move all control handles back and forth to relieve system pressure *before changing or adjusting hydraulic system components* such as hoses, tubing, fittings or other components.
- **Replace labels.** Always make sure safety labels are in place and in good condition. If a safety label is missing or not legible, order new labels because unsafe operation can result. Call 1-866-443-2576 to order new safety labels.

Splitting Operation

1. Put on protective clothing / gear

Wear the following protective clothing and safety gear:

- 1) **Eye protection.** Always wear safety glasses or goggles when operating the machine. Pieces of log may fly out and serious eye injury can occur.
- 2) **Boots.** Falling logs can crush feet. Always wear safety shoes or heavy boots when operating or helping to load logs.
- 3) **Gloves.** Wear snug fitting gloves without drawstrings or loose cuffs.
- 4) **Hearing protection.** The use of earplugs or other hearing protection device is recommended.
- 5) **No Loose/dangling apparel.** Loose or dangling apparel can become entangled in moving parts. Never wear jewelry or loose-fitting clothing.

2. Block wheels

Block the wheels to prevent unintended movement of the log splitter.

3. Set to horizontal or vertical:

Set log splitter into either the horizontal or vertical splitting position

The HORIZONTAL splitting position is used for lighter logs that can be easily loaded onto the beam. The VERTICAL splitting position is used for light logs as well as heavy logs that are difficult to load onto the beam.

Note:

Musculoskeletal injury can result from lifting logs onto the log splitter if proper lifting techniques are not used or the logs are too heavy for a person's size, weight, or strength. In some cases, logs as small as 8" in diameter and 14" in length may be heavier than what some persons should be repeatedly lifting onto the splitter.

The use of the vertical splitting position can greatly reduce the need to lift logs onto the splitter. Employers are advised to consider NIOSH lifting guidelines when assigning employees to log splitting tasks for an extended period of time.

⚠ WARNING: NEVER change splitting positions with the engine running. You may contact the muffler and receive serious burns.

Horizontal Splitting Position.

Make sure beam is locked securely in the horizontal position by checking the horizontal lock.

a) Set to Horizontal position

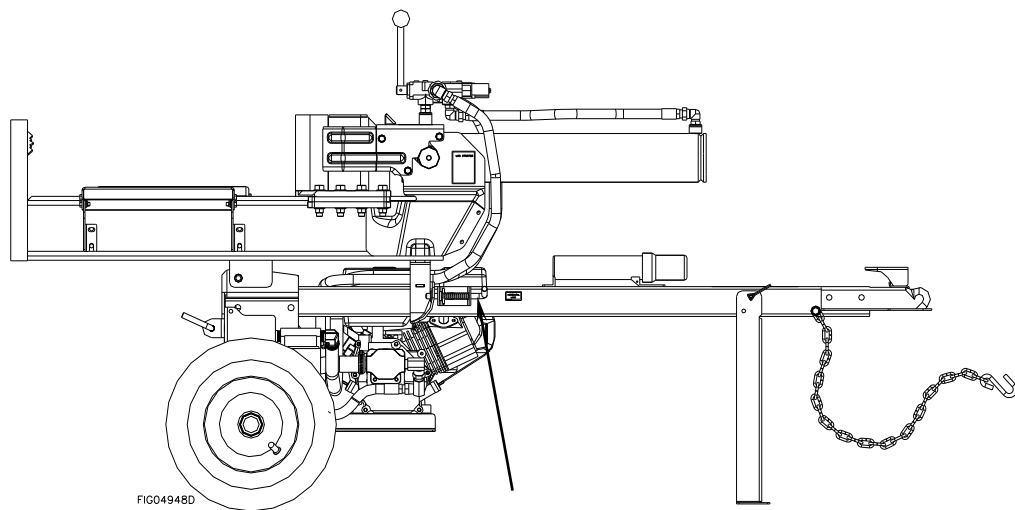

Horizontal Lock

Splitting Operation

b) Set to Vertical position

Vertical Splitting Position

Pull out horizontal lock latch rod, grasp and lift beam until it rotates into vertical position.

⚠ WARNING: Crush hazard. The beam is heavy – do not let it just drop. It could crush fingers or cause damage to the splitter.

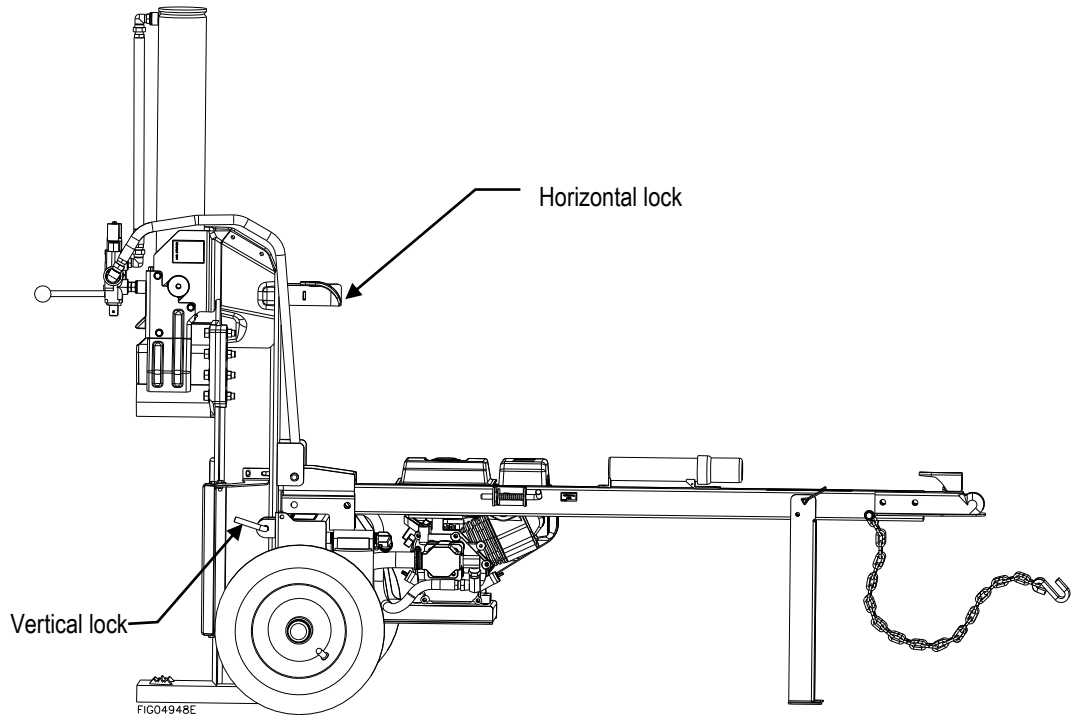

- 1) Lock in vertical position using latch rod through the vertical lock.
- 2) To return to horizontal position, unlock vertical latch rod, grasp and lower beam carefully in a controlled manner until it rests on the tow bar then lock beam in the horizontal position with latch rod.

4. Start engine

Start the engine.

See the engine owner's manual for engine starting instructions.

NOTE:

- a) Make sure the hydraulic oil is above 10°F before starting the engine. Cold hydraulic oil can damage the hydraulic pump.
- b) If outdoor air temperature is below 32°F, allow log splitter to warm up by extending and returning the wedge several times before splitting wood.

⚠ WARNING:

- **Burns.** To avoid burns, stay clear of hot muffler if you are starting a warm engine.
- **Carbon monoxide.** The running engine gives off carbon monoxide, a poisonous gas that can kill you. You CANNOT smell it, see it, or taste it. If you start to feel sick, dizzy, or weak while using the log splitter, shut off the engine and get to fresh air RIGHT AWAY. See a doctor. You may have carbon monoxide poisoning.
- **Other exhaust dangers.** Engine exhaust, some of its constituents, and certain vehicle components contain or emit chemicals known to the State of California to cause cancer, birth defects, or other reproductive harm. Avoid inhalation of exhaust.

Splitting Operation

5. Load log

Load log onto beam with a cut end against the end plate – positioned for a lengthwise cut.

Notes:

- a) The log splitter is designed only for cutting lengthwise with the grain, NOT for cutting across the grain.
- b) This log splitter is designed for cutting logs only up to a maximum of 14" in diameter and 25" long. Larger diameter logs could get stuck on the wedge and longer logs will not fit on the beam.

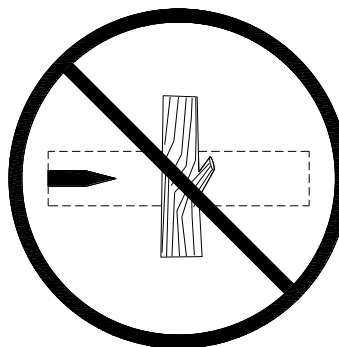
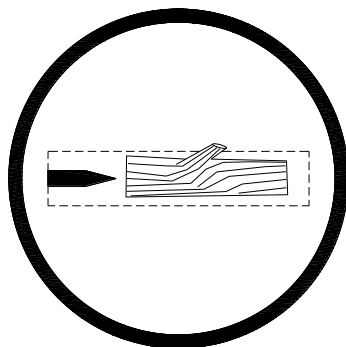

FIG00218

Correct Log Orientation

⚠️ WARNING: ALWAYS keep hands and feet away from the end plate, wedge, and partially split logs while loading, operating and unloading the log splitter.

Incorrect Log Orientation

Important safety instructions:

- **Hold bark side.** Hold the bark side of logs when loading or positioning, never the ends. Never place your hands or any part of your body between a log and any part of the log splitter.
NOTE for vertical position loading: Place the log on the endplate and turn it until it leans against the beam and is stable. If the log is too big or oddly shaped, stabilize the log with wooden shims between the log and endplate or ground. DO NOT use your leg or knee to stabilize the log. NEVER stabilize the log by placing your hand on top of the log.
- **Wedge moving.** NEVER load or unload logs while the wedge is moving.
- **Straddling/reaching across.** Never straddle, reach across, or step over the beam while the engine is running and the log splitter is in the horizontal position. You could trip, actuate the controls, and get seriously injured.
- **Unsplit log pile.** Do not pile logs to be split in a place that will make you reach across the log splitter in order to load them.
- **Square log ends.** Logs that are not cut square can slide out while splitting and become a safety hazard or cause excessive force to log splitter components. Use a chain saw to cut logs square on each end before attempting to split them.
- **Single log.** Never attempt to split more than one log at a time. Pieces of log can unexpectedly be thrown from the machine, causing serious injury.
- **Split along grain.** Do not use the log splitter to split logs across the grain. Doing so will damage the log splitter and could also cause pieces of log to be thrown, injuring the operator or bystanders.
- **Changing splitting position.** Do not change splitting positions (horizontal/vertical) with the engine running. You may contact the muffler and receive serious burns. Be careful to avoid contact with hot muffler even after the engine is turned off.

Splitting Operation

6. Extend wedge

Move Split Control Lever toward end plate to extend wedge and split log.

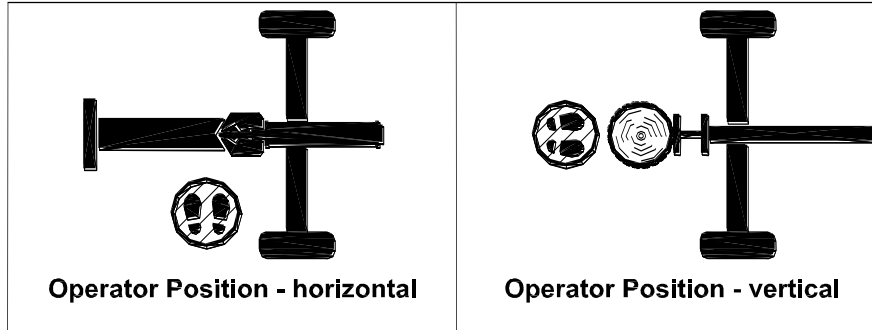
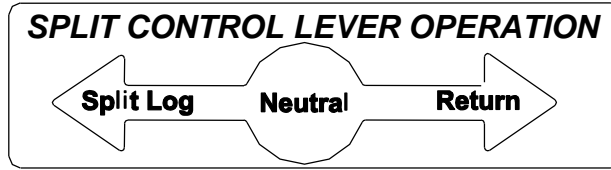

Important safety instructions:

- **Operator position.** ALWAYS operate the log splitter from the manufacturer's indicated OPERATOR POSITION. (See diagram above.) Other positions are unsafe because they can increase the risk of injury from crushing, cutting, flying objects, or burns.
- **Remove hands.** Remove both hands from log before activating Split Control Lever.
- **Hand activate.** Use only your hand to operate the Split Control Lever. Never use any other body part, or a rope, cable, or other remote device to actuate the control.
- **Second person.** Many accidents occur when there is more than one person involved in loading and operating the log splitter. Only one person should operate the controls. If a second person is assisting in loading logs, the operator must NEVER actuate the Split Control Lever until the assistant and all bystanders are at least 10 feet away. NEVER allow an assistant to hold the log in place while the operator actuates the Split Control Lever.

7. Stop wedge

Release Split Control Lever to stop wedge movement when log is split.

⚠WARNING: Cracks in logs can close quickly and pinch fingers. Keep fingers away from any cracks that open in partially split logs.

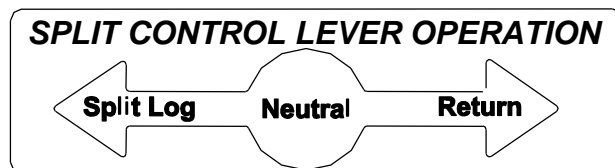

8. Important STUCK LOG procedure

If a log does not split completely and becomes stuck on the wedge, follow the instructions below to remove the log.

A log can become stuck to the wedge if the wedge becomes embedded in the log and the log doesn't split and separate. This can happen if the log is too stringy or tough to split completely.

A stuck log will move back with the wedge on the initial attempt to retract the wedge. If this happens, retract the wedge completely to allow the splitter to strip the log from the wedge. Keep hands clear of log and wedge while wedge is retracting.

Splitting Operation

- ⚠ WARNING: NEVER** attempt to remove a stuck log by:
- Modifying the splitter.
 - Adding attachments to the splitter.

Personal injury could result from log or metal pieces flying out at high speed toward the operator or bystanders, or the splitter could become damaged.

9. Return wedge

Move Split Control Lever away from end plate to return wedge.

Once the control valve is actuated in the return direction, the wedge is designed to keep returning by itself completely and then stop automatically.

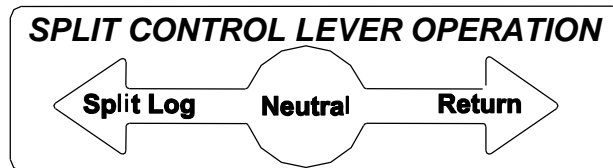

⚠ WARNING:

Stay clear while the wedge is returning. It is still powerful enough on the return stroke to cause serious injury.

10. Remove split wood

Remove split wood from area.

Move each log away from log splitter after it is split. Split logs left near the log splitter are a trip hazard.

11. After use

1. **Turn off engine.**
2. **Remove engine debris.**
Debris on a hot engine can be a fire hazard. After the engine is off, clean debris and chaff from engine cylinder head, cylinder head fins, blower housing rotating screen, and muffler areas.

⚠ WARNING: Avoid contact with hot muffler.

3. **Return to horizontal position.**

If in the vertical position, return log splitter to the horizontal position for greater stability and to prepare for transportation. Avoid contact with hot muffler.

Storage



WARNING

Gasoline vapors can ignite and cause a fire. Select a well-ventilated storage away from sources of heat, flame, or sparks.

Follow the instructions below for storing your log splitter between uses.

1. Retract wedge	Retract the wedge completely to keep the rod protected from corrosion.
2. Cool	<p>Allow the machine to cool 5 minutes before storing.</p> <p>⚠ WARNING: A hot engine can be a fire hazard.</p>
3. Wipe with oily rag	Wipe the beam and wedge with an oily rag to prevent corrosion.
4. Engine manual	<p>Refer to the engine manual for proper engine storage instructions.</p> <p>CAUTION: Gasoline will oxidize and deteriorate in storage. Old gasoline in the engine will cause hard starting and leave gum deposits that can clog the fuel systems. Deterioration problems may occur within a few months, or even less if gasoline was not fresh when you filled the tank.</p> <p><u>Short-Term Storage:</u></p> <ol style="list-style-type: none"> 1. Consider adding a fuel stabilizer to extend fuel storage life. 2. Leave the fuel valve lever in the OFF position to reduce the possibility of fuel leakage. <p><u>Long-Term Storage:</u> (between infrequent uses and at end of season) Drain the fuel tank and carburetor as instructed in the engine owner's manual.</p> <p><u>Important Safety Instructions</u></p> <ul style="list-style-type: none"> • Always drain fuel from tank in outdoor, well-ventilated area. • Stay away from sources of heat, flame, or sparks while handling fuel. • Clean up fuel spills/splashes immediately.
5. Splitter storage location	<p>Store the log splitter in a location away from corrosive material, sources of heat, open flames, sparks or pilot lights.</p> <p>⚠ WARNING: Never store log splitter inside where there is a source of heat or an open flame, spark or pilot light – such as water heaters, space heaters, furnaces, clothes dryers, or other gas appliances – EVEN IF the log splitter's gas tank is empty, residual gasoline vapors could ignite.</p> <p>NOTE: Do not store the log splitter near fertilizer or any other corrosive material.</p>
6. Gasoline storage	<p>Store gasoline in a cool, dry place in an UL listed tightly sealed container.</p> <p>⚠ WARNING: Gasoline vapors can ignite if they collect inside an enclosure and explosion can result.</p>

Periodic Maintenance



In addition to the maintenance performed with each use, periodic maintenance should also be performed according to the following schedule.

 **WARNING**

ALWAYS shut off the engine, disconnect the spark plug, and relieve system pressure before cleaning, adjusting, or repairing the splitter. Relieve system pressure by moving Split Control Lever back and forth several times.

IMPORTANT:

If a part needs replacement only use parts that meet the manufacturer's specifications. Replacement parts that do not meet specifications may result in a safety hazard or poor operation of the log splitter.

1. Engine maintenance	Perform engine maintenance as specified in engine owner's manual.
2. Hydraulic Oil Change	<p>Change Hydraulic Oil Annually or Every 100 Hours.</p> <p> WARNING: High fluid pressures and temperatures are developed in hydraulic log splitters. Hydraulic fluid escaping through a pin hole sized opening can burn or puncture skin, resulting in wounds that could cause blood poisoning, infection, disability, gangrene, amputation, or death. Therefore, the following instructions should be heeded at all times when inspecting or servicing the hydraulic components of the log splitter.</p> <ul style="list-style-type: none"> • NEVER check for leaks with your hand. Leaks can be located by holding a piece of cardboard or wood (at least two feet long) with your hand at one end and passing the other end over the suspected area (wear eye protection). Look for discoloration of the cardboard or wood. • NEVER adjust the pressure of the pump or valve. • If injured by escaping fluid, no matter how small the wound is, see a doctor at once. A typical injection injury may be a small wound that does not look serious. However, severe infection or reaction can result if proper medical treatment is not administered immediately by a doctor who is familiar with injection injuries. <ol style="list-style-type: none"> 1. Use 10wt AW32, ASLE H-150, or ISO32 oil. 2. Relieve hydraulic system pressure by moving Split Control Lever back and forth several times. 3. Remove hydraulic oil fill/vent cap. <p> WARNING: NEVER remove the hydraulic oil fill/vent cap when the engine is running or hot. Hot oil can escape causing severe burns. Allow the log splitter to cool completely before removing hydraulic oil fill/vent cap.</p> <ol style="list-style-type: none"> 4. Remove the suction strainer from the hydraulic tank to drain the hydraulic oil into a 10-gallon pan. 5. Clean suction strainer and wipe off debris with a dry cloth. 6. Fill the hydraulic tank with wedge retracted. 7. Dispose of used oil at an oil-recycling center. Used hydraulic oil is hazardous waste. 8. Extend and retract wedge five (5) times to purge air from the system. 9. Check hydraulic oil level and fill if necessary.
3. Spark arrestor muffler	If the engine is equipped with a spark arrestor muffler, clean and inspect it regularly (follow manufacturer's service instructions). Replace if damaged.

Troubleshooting

WARNING

Before troubleshooting or attempting to service, read the following safety instructions to avoid serious injury to the operator or bystanders from moving parts that can crush or cut, burns, fire or explosion, or escaping high pressure hydraulic fluid.

Important Safety Instructions:

1. **Engine off.** Always make sure the engine is off before cleaning, repairing or adjusting the splitter, except as recommended by the manufacturer.
2. **Hydraulic safety.** High fluid pressures and temperatures are developed in the hydraulic log splitters. Hydraulic fluid escaping through a pin hole sized opening can burn or puncture skin, resulting in wounds that could cause blood poisoning, infection, disability, gangrene, amputation, or death. Therefore, the following instructions should be heeded at all times when inspecting or servicing the hydraulic components of the log splitter:
 - Stop the engine, disconnect the spark plug, and move all control valve handles back and forth to relieve pressure before changing or adjusting hydraulic components such as hoses, tubing, fittings, or other components.
 - Do not remove the hydraulic oil fill cap when the engine is running. Hot oil can escape causing severe burns. Allow the log splitter to cool completely before removing the hydraulic oil fill cap.
 - Do not adjust the pressure setting to the pump or valve.
 - Do not check for leaks with your hands. Leaks can be located by holding a piece of cardboard or wood (at least 2 feet long) with your hand at one end and passing the other end suspected area (wear eye protection). Look for discoloration of the cardboard or wood.
 - If injured by escaping fluid, no matter how small the wound is, see a doctor at once. A typical injection injury may be a small puncture that does not look serious. However, severe infection or reaction can result if proper medical treatment is not administered immediately by a doctor who is familiar with injection injuries.

Problem	
Wedge will not move	Solution: A,D,E,H,J
Slow wedge speed when extending or retracting	Solution: A,B,C,H,I,K
Wood will not split or splits extremely slow	Solution: A,B,C,F,I,K
Engine bogs down during splitting	Solution: G
Engine stalls under low load condition	Solution: D,E
Cause	Solution
A- Insufficient oil to pump	Check oil level in reservoir
B- Air in oil	Check oil level in reservoir, check for leaks in the suction line
C- Excessive pump inlet vacuum	Check pump inlet hose for blockage or kinks
D- Blocked hydraulic lines	Flush and clean the splitter hydraulic system
E- Blocked control valve	Flush and clean the splitter hydraulic system
F- Low control valve setting	Adjust control valve with a pressure gauge
G- High control valve setting	Adjust control valve with a pressure gauge
H- Damaged control valve	Return control valve for authorized repair
I- Internal control valve leak	Return control valve for authorized repair
J- Damaged cylinder piston	Return cylinder for authorized repair
K- Internally damaged cylinder	Return cylinder for authorized repair

Any Questions, Comments, Problems or Parts Orders
Call Powerhorse Product Support 1-866-443-2576

Specifications

Item #	1169
Tonnage.....	35 TON
Pressure.....	3350 PSI
Flow.....	16 GPM
Engine cc.....	420cc
Hydraulic Cylinder Bore....	5"
Hydraulic Cylinder Stroke ..	24 in
Maximum Log Diameter....	14"
Maximum Log Length	25"
Hydraulic Fluid Type.....	10wt AW32, ASLE H-150, or ISO32
Hydraulic Oil Capacity.....	6.6 gallons
Maximum Towing Speed...	45 MPH
Coupler Size.....	2" Ball
Spark Arrestor.....	No
Fuel Valve.....	Yes
Overall Dimensions	86.5"L x 43"W x 15.5"H
Dry Weight.....	596 lb.

The manufacturer reserves the right to make improvements in design and/or changes in specifications at any time without incurring any obligation to install them on units previously sold.

Any Questions, Comments, Problems or Parts Orders
Call Powerhorse Product Support 1-866-443-2576

Parts Breakdown – Exploded View 1169 – Rev H

Item	Part No.	Description	Qty.
1	124A	Dust cap	2
2	777124	Axle nut	2
3	778674	1/8" x 2" Cotter pin	3
4	778844	Wheel washer	2
5	791875	Wheel	2
6	788243	Latch rod	1
7	788245	Latch spring	2
8	788244	Latch rod pin	2
9	790805	Powerhorse tank decal	1
10	790181	Tank weldment	1
11	790472	Pivot pin	1
12	790470	Suction strainer	1
13	788504	Suction elbow fitting	1
14	777835	Hose clamp	2
15	790483	Suction hose 1" x 18"	1
16	777911	Engine coupler	1
17	777912	Coupler insert	1
18	777909	Pump coupler	1
19	779683	Pump Mount	1
20	799394	16 GPM Pump	1
21	790485	3/4" x 59" Return hose	1
22	799399	Hose clamp, 3/4"	2
23	778829	Return Line Fitting	1
24	791244	Return Line Filter Head	1
25	791246	Return Line Filter Canister	1
26	790489	Supply hose 1/2" x 56"	1
27	50RAS8	Pump Fitting	1
28	798736	Powerhorse Engine 420cc	1
29	790533	Log cradle mount	4
30	790540	Log cradle face plate	2
31	790359	Keeper	2
32	790357	Spacer	2
33	790515	Wedge	1
34	82570	Wedge Nut	1
35	82525	Keeper Bolt	12
36	790405	Log stripper weldment	1
37	778827	Small swivel fitting	2
38	790488	Valve fitting	1
39	791869	Control valve	1
40	778642	Hose barb fitting	1
41	778831	Large swivel fitting	1
42	778619	Cylinder extension hose	1

Parts Breakdown – Exploded View 1169 – Rev H

Item	Part No.	Description	Qty.
43	790228	Cylinder 5" x 24"	1
44	790813	35 Ton Decal	2
45	82573	Wedge bolt	1
46	82570	Keeper Nut	12
47	790511	Beam weldment	1
48	790522	Horizontal beam lock	1
49	790471	Manual tube, mini	1
50	791066	Powerhorse beam decal	2
51	790204	Tow bar weldment	1
52	778423	Coupler	1
53	1130	Safety chains	2
54	778916	Pin catch, 5/16" x 3 1/2"	1
55	790344	Support leg	1
56	788243	Latch rod	1
57	780599	Dust cap tool	1
58	784470	Breather/Dipstick	1
59	N/A	Serial Number Decal	1
60	791545	Spacer	2

Summary of Important Safety Information for Operation



WARNING

Carefully read and make sure you understand the following safety information before using the log splitter.

Improper use or maintenance of the log splitter can result in serious injury to the operator or bystanders from moving parts that can crush or cut, flying objects, burns, fire or explosion, escaping high pressure hydraulic fluid, or carbon monoxide poisoning.

Introduction

- **Read Manual.** Read this operator's manual and the engine Owner's Manual completely before attempting to use the log splitter. Serious injury or death can result if safety instructions are not followed.
- **Instruct operators.** The log splitter owner should instruct all operators in safe log splitter operation.
- **Intended use.** Log splitters should only be used for splitting wood logs, lengthwise with the grain. Do not use for other purposes, as unforeseen hazards may result.

Prohibition Against Modifications

Never modify or alter the log splitter in any way. Modifications can create serious safety hazards and will void the warranty.

- **Attachments.** Never add attachments to the splitter, except for authorized accessories supplied by the manufacturer with instructions for safe installation and use.
- **Engine Speed.** The maximum engine speed is preset at a safe limit. Never attempt to modify the engine speed setting to run at a higher speed.
- **Fuel/Exhaust system.** NEVER modify or add to the exhaust system, fuel tanks, or fuel lines. Fire can result.
- **Remote Control.** NEVER attach a rope, cable, or other remote device to the splitting control.
- **Splitting Wedge.** NEVER attempt to change the height or speed of the splitting wedge.
- **Pressure Setting.** NEVER increase the pressure setting of the pump or control valve.

Operator Restrictions

- **Untrained Operators.** Do not allow anyone to operate the log splitter who has not read the owner's manual or been instructed on the safe use of the splitter.
- **Minimum Operator Age.** Never allow anyone under age 16 to operate the log splitter. Anyone 16 years of age and older must be trained and supervised by a trained adult.

Safety in Moving and Towing the Log Splitter



WARNING

The log splitter is very heavy. It can cause serious injury if it rolls out of control or tips over.

Follow the safety instructions below for safely moving the log splitter.

General Safety while Moving

- **Horizontal position.** Make sure the log splitter is secured in the horizontal position before moving the log splitter. DO NOT move the log splitter when it is in the vertical position because it will be unstable and could tip.
- **Hills.** Do not move the log splitter up or down hills by hand – use a towing vehicle.
- **Engine off.** Never move the log splitter with its engine running.
- **No riding.** Never allow anyone to sit or ride on the log splitter.
- **No cargo.** Never transport cargo or wood on the log splitter.

Safety During Towing

- **Read instructions.** Review towing safety instructions in your towing vehicle manual.
- **Securely attached.** Be sure the log splitter is securely attached to the towing vehicle before towing.

Summary of Important Safety Information for Operation

- **Tires.** Be sure the tires are fully inflated and in good repair before towing the log splitter. When adding air to the tires, do not over-inflate – serious injury could occur if tire explodes.
- **Added length.** Be aware of the added length of the splitter.
- **Speed limit.** Never tow this log splitter over 45 mph. Faster speeds may result in loss of control.
- **Rough terrain.** Be extra cautious and drive slowly when traveling over rough terrain.
- **Under the influence.** Never tow this splitter while under the influence of alcohol, drugs, or medication.
- **On public roads.** If towing on a public road, make sure to comply with all local, state, and federal towing requirements. It is the sole responsibility of the purchaser to obtain licensing, trailer lights, safety chains or signage, as needed to comply.
- **Unattended.** Turn off the towing vehicle before leaving the splitter unattended.
- **Disconnect before operating.** Do not use the log splitter while it is connected to the towing vehicle.

Safety – Before Use

Read/instruct

- **Read manual.** Do not allow anyone to operate the log splitter who has not read the owner's manual or has not been instructed on the safe use of the splitter.
- **Review safety rules.** Before starting this log splitter, review the "Rules for Safe operation." Failure to follow these rules may result in serious injury to the operator or bystanders.
- **Know how to stop.** Be thoroughly familiar with all controls and proper use of the equipment. Know how to stop the splitter and relieve system pressures quickly if needed.

Personal protective equipment

- **Eye protection.** Always wear safety glasses or goggles when operating the machine. Pieces of log may fly out and serious eye injury can occur.
- **Boots.** Falling logs can crush feet. Always wear safety shoes or heavy boots when operating or helping to load logs.
- **Loose/dangling apparel.** Loose or dangling apparel can become entangled in moving parts. Never wear jewelry or loose-fitting clothing.
- **Gloves.** Wear snug fitting gloves without drawstrings or loose cuffs.
- **Hearing protection.** The use of earplugs or other hearing protection device is recommended.

Safety During Inspection/Maintenance

Always inspect your log splitter before each use, and repair as needed, to keep it in safe working condition:

- **Engine off.** Always make sure the engine is off before cleaning, repairing or adjusting the splitter, except as recommended by the manufacturer.
- **Engine debris.** Debris on a hot engine can be a fire hazard. With the engine off, clean debris and chaff from engine cylinder head, cylinder head fins, blower housing rotating screen, and muffler areas. Avoid contact with hot muffler.
- **Other debris.** Debris on moving parts can cause excess wear. With the splitter engine off, clear debris from moving parts.
- **Fuel tank/lines.** Before each use, check fuel tank and fuel lines for leaks. Any fuel leak is a fire hazard. Fix any fuel leaks before starting engine.
- **Mechanical parts.** Check to be sure that all nuts and bolts are tight to make sure the log splitter is in safe working condition.
- **Hydraulic system.** Check the hydraulic system (hoses, tubing, clamps/fittings, pump, and cylinder) carefully before each use. Do not operate the log splitter with frayed, kinked, cracked or damaged hydraulic hoses, fittings, or tubing, or if oily residue is observed on any of the components. High fluid pressures and temperatures are developed in the log splitter. Hydraulic fluid escaping through a pin hole sized opening can burn or puncture skin, resulting in wounds that could cause blood poisoning, infection, disability, gangrene, amputation, or death. Therefore, the following instructions should be heeded at all times when inspecting or servicing the hydraulic components of the log splitter:
 - Do not remove the hydraulic oil fill/vent cap when the engine is running. Hot oil can escape causing severe burns. Allow log splitter to cool completely before removing hydraulic oil fill/vent cap.
 - Do not adjust the pressure setting of the pump or valve.

Summary of Important Safety Information for Operation

- Do not check for leaks with your hand. Leaks can be located by holding a piece of cardboard or wood (at least two feet long) with your hand at one end and passing the other end over the suspected area (wear eye protection). Look for discoloration of the cardboard or wood.
- Stop the engine, disconnect the spark plug, and move all control valve handles back and forth to relieve pressure before changing or adjusting hydraulic system components such as hoses, tubing, fittings or other components.
- If injured by escaping fluid, no matter how small the wound is, see a doctor at once. A typical injection injury may be a small puncture wound that does not look serious. However, severe infection or reaction can result if proper medical treatment is not administered immediately by a doctor who is familiar with injection injuries
- **Spark arrestor muffler.** If the engine is equipped with a spark arrestor muffler, clean and inspect it regularly (follow manufacturer's service instructions). Replace if damaged.
- **Tires.** Be sure tires are fully inflated and in good repair before towing the splitter. When adding air to tires, do not over-inflate -- serious injury could occur if tire explodes.
- **Guards/shields.** Make sure all guards and shields are replaced after servicing the log splitter.
- **Replacement parts.** If a part needs replacement, only use parts that meet the manufacturer's specifications. Replacement parts that do not meet specifications may result in a safety hazard or poor operation of the log splitter.

Safety During Fueling

- Gasoline is highly flammable and explosive. You can be burned or seriously injured when handling fuel. Use extreme care when handling gasoline:
- **Fuel outdoors.** Fill fuel tank outdoors – never indoors. Gasoline vapors can ignite if they collect inside an enclosure. Explosion can result.
- **Use approved container.** Never pump fuel directly into engine at gas station. Static charge can build and ignite fuel. Use an UL listed fuel container to transfer gas to the engine.
- **Running/hot engine.** A running engine is hot enough to ignite fuel. Never add fuel or remove gas cap if engine is running or still hot. Stop the engine and allow to cool at least two minutes before adding fuel.
- **Heat/flames/sparks.** Stay away from sources of heat, flame, or sparks while adding fuel.
- **Don't overfill.** DO NOT overfill the gas tank. Allow at least 1/2" of empty space below the fill neck to allow for fuel expansion.
- **Replace cap.** Replace gas cap securely before starting engine.
- **Spills.** Clean up fuel spills immediately. Move log splitter away from spilled fuel on the ground. Wipe fuel off engine and wait 5 minutes for excess fuel to evaporate before starting engine. Gas soaked rags should be disposed of properly.
- **On skin/clothes.** If gasoline is spilled on your skin or clothes, change clothes and wash skin immediately.
- **Gasoline storage.** Store gasoline in a cool, dry place in an UL listed, tightly sealed container.

Safety in Work Site Selection

- **Spark arrestor.** If your splitter will be used near any unimproved forest, brush, or grassy covered land, then engine should be equipped with a spark arrestor. See the "Specifications" section of this manual to determine if your splitter already has a spark arrestor. Make sure you comply with applicable local, state and federal codes.
- **Hot exhaust.** Hot exhaust fumes from engine can cause fire. Position muffler at least 7' from combustible objects during operation.
- **Fire extinguisher.** Have an "ABC" rated fire extinguisher available as a precautionary measure when operating the log splitter in dry areas.
- **Level, dry surface.** To prevent accidental falls and equipment tip over, make sure the splitter is situated on a dry, level surface with good footing. Stay clear of areas with mud, ice, tall grass, weeds, brush, or snow.
- **Block wheels.** Always block the wheels to prevent unintended movement of the log splitter.
- **Carbon monoxide.** The running engine gives off carbon monoxide, a poisonous gas that can kill you. You CANNOT smell it, see it, or taste it. ONLY run log splitter OUTDOORS and away from air intakes. NEVER run log splitter inside homes, garages, sheds, or other semi-enclosed spaces. These spaces can trap poisonous gases, EVEN if you run a fan or open windows. If you start to feel sick, dizzy, or weak while using the log splitter, shut off the engine and get to fresh air RIGHT AWAY. See a doctor. You may have carbon monoxide poisoning.

Summary of Important Safety Information for Operation

Safety – During Use General Safety During Use

 **WARNING:** Before starting this log splitter, review the following rules for safe operation. Failure to follow these rules may result in serious injury to the operator or bystanders.

- **Safety equipment / controls.** Always operate the log splitter with all safety equipment in place and in good working order, and all controls properly adjusted for safe operation.
- **Operating speed.** Always operate the log splitter at the manufacturer's recommended speed. The maximum speed of the engine, pump and wedge are preset within safe limits.
- **Know how to stop.** Be thoroughly familiar with all controls and with the proper use of the equipment. Know how to stop the log splitter and relieve system pressures quickly if needed.
- **Daylight only.** Only use the log splitter in daylight so you can see what you are doing.
- **Smoking/sparks.** Never smoke while operating the log splitter, and never operate near sources of sparks or flames.
- **Hot muffler.** If you are starting a warm engine, stay clear of muffler. It may still be hot enough to burn you.
- **Unattended.** Never leave the machine unattended while the engine is running.
- **Under the influence.** Never operate, or let anyone else operate, the log splitter while under the influence of alcohol, drugs, or medication.
- **Adjusting/repairing.** Always make sure the engine is off before cleaning, repairing or adjusting the splitter, except as recommended by the manufacturer. In addition, disconnect the spark plug and move all control handles back and forth to relieve system pressure *before changing or adjusting hydraulic system components* such as hoses, tubing, fittings or other components.
- **Carbon monoxide.** The running engine gives off carbon monoxide, a poisonous gas that can kill you. You CANNOT smell it, see it, or taste it. If you start to feel sick, dizzy, or weak while using the log splitter, shut off the engine and get to fresh air RIGHT AWAY. See a doctor. You may have carbon monoxide poisoning.
- **Other exhaust dangers.** Engine exhaust, some of its constituents, and certain vehicle components contain or emit chemicals known to the State of California to cause cancer, birth defects, or other reproductive harm. Avoid inhalation of exhaust.

Safety in Loading, Operating, and Unloading

- **Square log ends.** Logs that are not cut square can slide out while splitting and become a safety hazard or cause excessive force to log splitter components. Use a chainsaw to cut logs square on each end before attempting to split them.
- **Single log.** Never attempt to split more than one log at a time. Pieces of log can unexpectedly be thrown from the machine causing serious injury.
- **Split along grain.** Do not use the log splitter to split logs across the grain. Doing so will damage the log splitter and could also cause pieces of log to be thrown, injuring the operator or bystanders.
- **Keep hands clear.** ALWAYS keep hands and feet away from the endplate, wedge, and partially split logs while loading, operating and unloading the log splitter.
- **Operator position.** ALWAYS operate the log splitter from the manufacturer's indicated OPERATOR POSITION. Other positions are unsafe because they can increase the risk of injury from crushing, cutting, flying objects, or burns.
- **Straddling/reaching across.** Never straddle, reach across, or step over the beam while the engine is running and the log splitter is in the horizontal position. You could trip, actuate the controls, and get seriously injured.
- **Second person.** Many accidents occur when there is more than one person involved in loading and operating the log splitter. Only one person should operate the controls. *If a second person is assisting in loading logs, the operator must NEVER actuate the Split Control Lever until the assistant and all bystanders are at least 10 feet away. NEVER allow an assistant to hold the log in place while the operator actuates the Split Control Lever.*
- **Loading/Unloading**
- **Unsplit log pile.** Do not pile logs to be split in a place that will make you reach across the log splitter in order to load them.
- **Hold bark side.** Hold the bark side of logs when loading or positioning, never the ends. Never place your hands or any part of your body between a log and any part of the log splitter.

Summary of Important Safety Information for Operation

- **NOTE for vertical position loading:** Place the log on the endplate and turn it until it leans against the beam and is stable. If the log is too big or oddly shaped, stabilize the log with wooden shims between the log and endplate or ground. DO NOT use your leg or knee to stabilize the log. NEVER stabilize the log by placing your hand on top of the log.
- **Wedge moving.** NEVER load or unload logs while the wedge is moving.
- **Cracks.** Cracks in logs can close quickly and pinch fingers. Keep fingers away from any cracks that open in partially split logs.
- **Split log pile.** Move each log away from log splitter after it is split. Split logs left near the log splitter are a trip hazard.
- **Remove hands.** Remove both hands from log before activating Split Control Lever.
- **Hand activate.** Use only your hand to operate the Split Control Lever. Never use any other body part, or a rope, cable, or other remote device to actuate the control.
- **Returning wedge.** Once the control valve is actuated in the return direction, the wedge is designed to keep returning by itself completely and then stop automatically. Stay clear while the wedge is returning. It is still powerful enough on the return stroke to cause serious injury.
- **Log stuck on wedge.** If a log does not split completely and becomes stuck on the wedge, follow the instructions below to remove the log. A log can become stuck to the wedge if the wedge becomes embedded in the log and the log doesn't split and separate. This can happen if the log is too stringy or tough to split completely. A stuck log will move back with the wedge on the initial attempt to retract the wedge. If this happens, retract the wedge completely to allow the splitter to strip the log from the wedge. Keep hands clear of log and wedge while wedge is retracting.

⚠WARNING: NEVER attempt to remove a stuck log by:

- Modifying the splitter.
- Adding attachments to the splitter.

Personal injury could result from log or metal pieces flying out at high speed toward the operator or bystanders, or the splitter could become damaged.

- **Changing splitting position.** Do not change splitting positions (horizontal/vertical) with the engine running. You may contact the muffler and receive serious burns. Be careful to avoid contact with hot muffler even after the engine is turned off.
- **Refueling.** Never refuel the engine until it has cooled at least two minutes.

Safety – After use

- **Return to horizontal.** If in the vertical position, turn off engine and return log splitter to the horizontal position for greater stability and to prepare for transportation. Avoid contact with hot muffler.
- **Remove engine debris.** Debris on a hot engine can be a fire hazard. With the engine off, clean debris and chaff from engine cylinder head, cylinder head fins, blower housing rotating screen, and muffler areas. Avoid contact with hot muffler.
- **Let engine cool before storing.** Let engine cool for at least five minutes before storing. A hot engine can be a fire hazard.
- **Storage location.** Store the log splitter in a location away from sources of heat, open flames, sparks or pilot lights – such as water heaters, space heaters, furnaces, clothes dryers, or other gas appliances. Even if the log splitter's gas tank is empty, residual gasoline vapors could ignite.
- **Gasoline storage.** Store extra gasoline in a cool, dry place in an UL listed, tightly sealed container. Gasoline vapors can ignite if they collect inside an enclosure.
- **Periodic maintenance.** Perform periodic maintenance as directed in this manual to keep the log splitter in safe working condition.

Assembly Instructions

Closely inspect all log splitter components.

If you have missing or damaged components, please contact Powerhorse Product Support at 1-866-443-2576.

⚠CAUTION! Heavy lifting required. Some of the components in these assembly instructions are heavy and cannot be lifted by one person safely. Please plan on assembling this product when another person can be available to help out.

CAUTION! Remove the cylinder from the beam/tank assembly before assembling. The cylinder is locked in place for shipping purposes in a backwards orientation.

⚠CAUTION! Hose clamp orientation: When assembling hose clamps, orient the runout-tab so that it is out of the way of any interaction points on the log splitter.

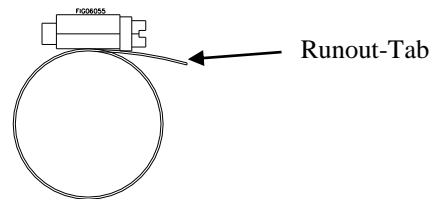

Tools needed: Adjustable Wrenches, Torque Wrench, Soft Faced Mallet, Flat Blade Screw Driver, Socket Wrench

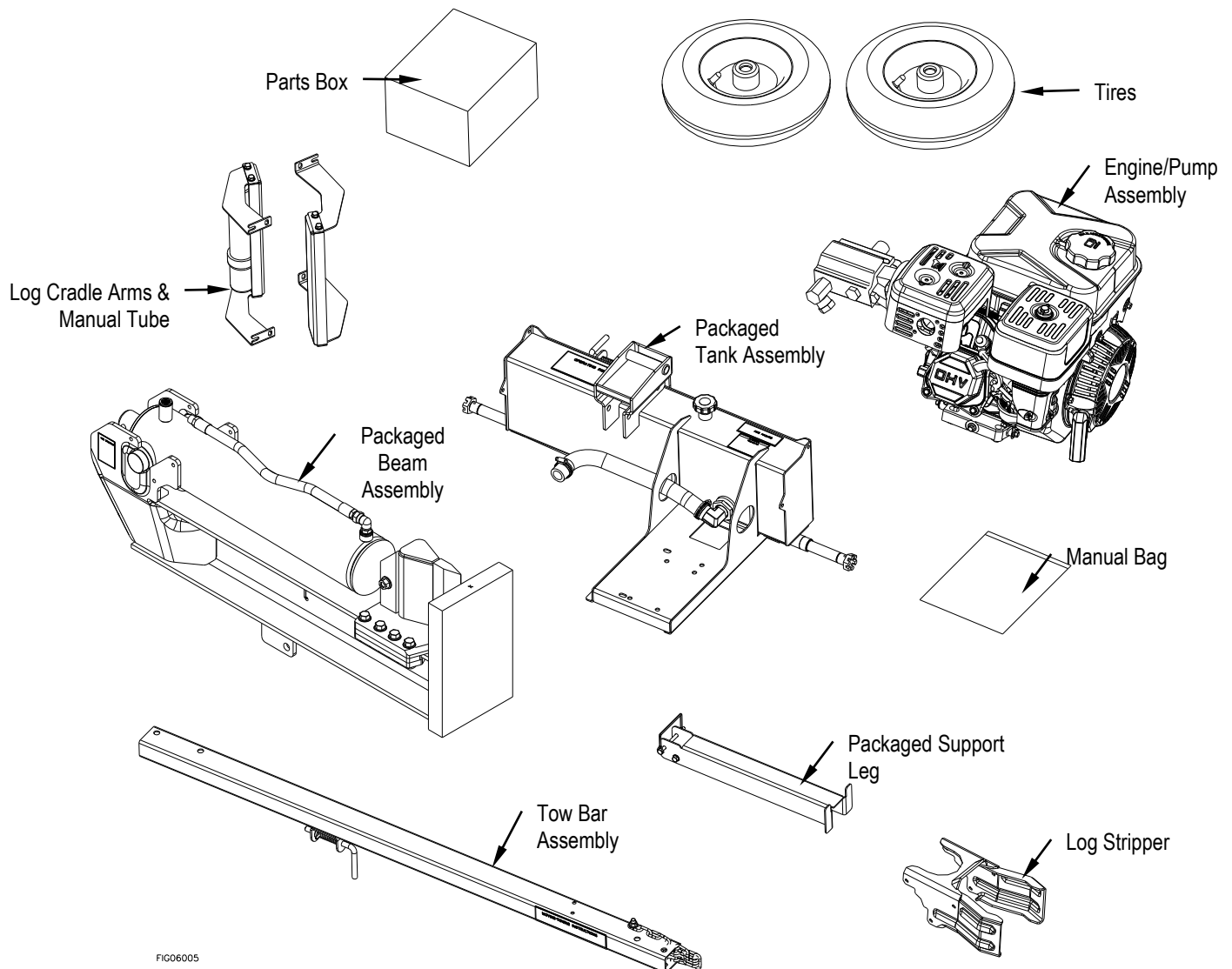

Assembly Instructions

Manual Bag Contents

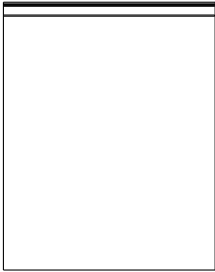

Manual

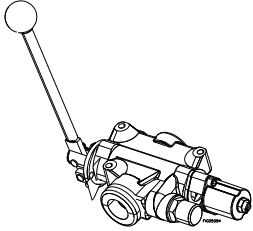

Valve

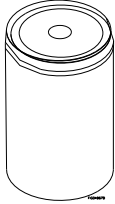

Filter Canister

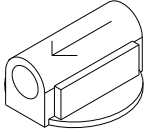

Filter Head

Parts Box Contents

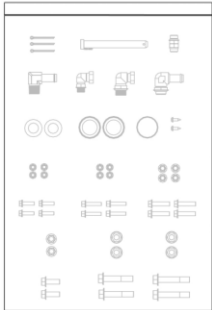

Parts Bag

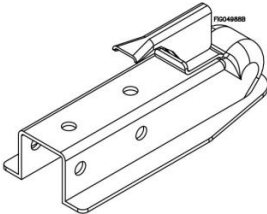

Coupler

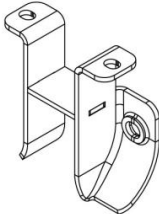

Horizontal Latch Bracket

Assembly Instructions

Fastener Bag Contents:

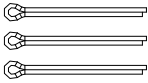

Part # 778674
Cotter Pin
Qty: 3

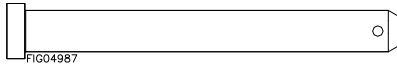

Part # 790472
Beam Pivot Pin
Qty: 1



Part # 790488
Valve Fitting
Qty: 1

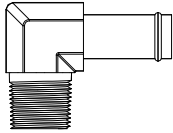

Part # 778829
Return Line Fitting
Qty: 1

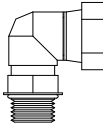

Part # 778827
Small Swivel Fitting
Qty: 1

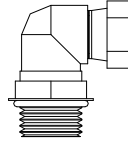

Part # 778831
Large Swivel Fitting
Qty: 1

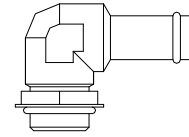

Part # 778642
Hose Barb Fitting
Qty: 1

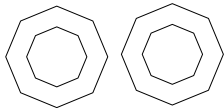

Part # 778844
Wheel Washer
Qty: 2

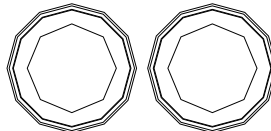

Part # 124A
Dust Cap
Qty: 2

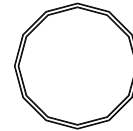

Part # 780599
Dust Cap Tool
Qty: 1



Part # 82529
Manual Tube to Tow Bar
Dust Cap Tool
Qty: 2

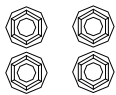

Part # 82281
Log Cradles to Beam
M8-1.25 HHSF Nut
Qty: 4

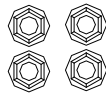

Part # 82281
Engine to Tank (1175)
M8-1.25 HHSF Nut
Qty: 4

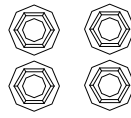

Part # 82271
Engine to Tank (1169)
M10-1.5 HHSF Nut
Qty: 4



Part # 82273
Horz. Latch to Beam
M12-1.75 HHSF Nut
Qty: 2

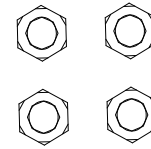

Part # 82272
M12-1.75 Nyloc Nut
Tow Bar to Tank and
Coupler to Tow Bar
Qty: 4

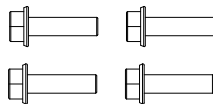

Part # 82545
Log Cradle to Beam
M8-1.25 x 30mm HHSF Bolt
Qty: 4

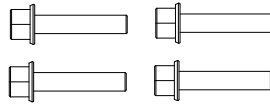

Part # 82280
Engine to Tank (1175)
M8-1.25 x 40mm HHSF Bolt
Qty: 4

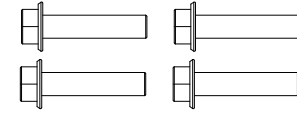

Part # 82536
Engine to Tank (1169)
M10-1.5 x 45mm HHSF Bolt
Qty: 4

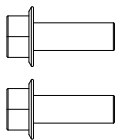

Part # 82551
Horz. Latch to Beam
M12-1.75 x 35mm HHSF Bolt
Qty: 2

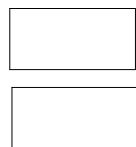

Part # 791545
Tow Bar Spacer
Qty: 2

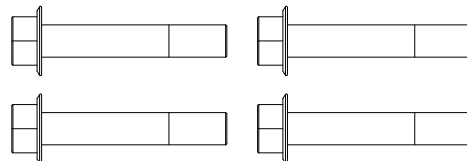

Part # 82528
Tow Bar to Tank
M12-1.75 x 8mm HHSF
Bolt
Qty: 4



Part # 791168
Hoses to Beam
Small Zip Tie
Qty: 4



Part # 791167
Hoses
Large Zip Tie
Qty: 1

Fastener Bag Contents Cont.:

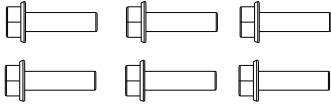

Part # 82545
Log Stripper to Beam (1169)
M8-1.25 x 30mm HHSF Bolt
Qty: 6

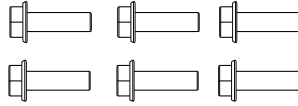

Part # 82561
Log Stripper to Beam (1175)
M8-1.25 x 25mm HHSF Bolt
Qty: 6

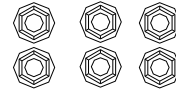

Part # 82281
Log Stripper to Beam
M8-1.25 HHSF Nut
Qty: 6

Assembly Instructions

Step 1 – Beam Assembly

- Rotate cylinder 180° and place cylinder in trunnion mounts on beam (see Step 2 image for the correct orientation)

Tools Needed

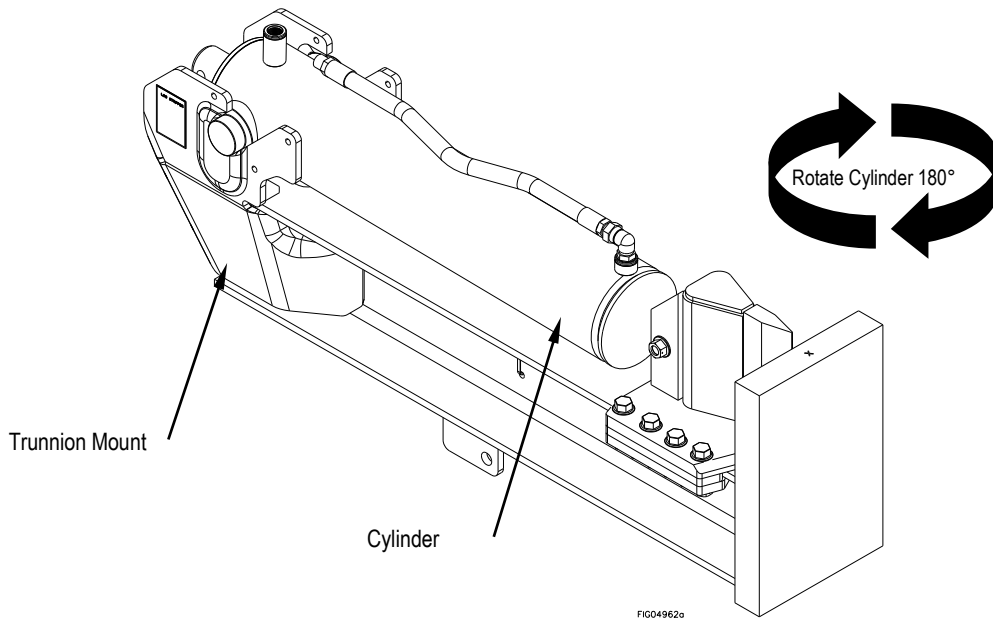

Assembly Instructions

Step 2 – Beam Assembly

- Support the end of the cylinder until connected to the wedge
- Ensure the ports on the cylinder are facing up
- Remove the existing bolt and nut from the wedge
- Slide wedge towards the cylinder rod

Tools Needed

- 22mm Wrench
(2 needed)

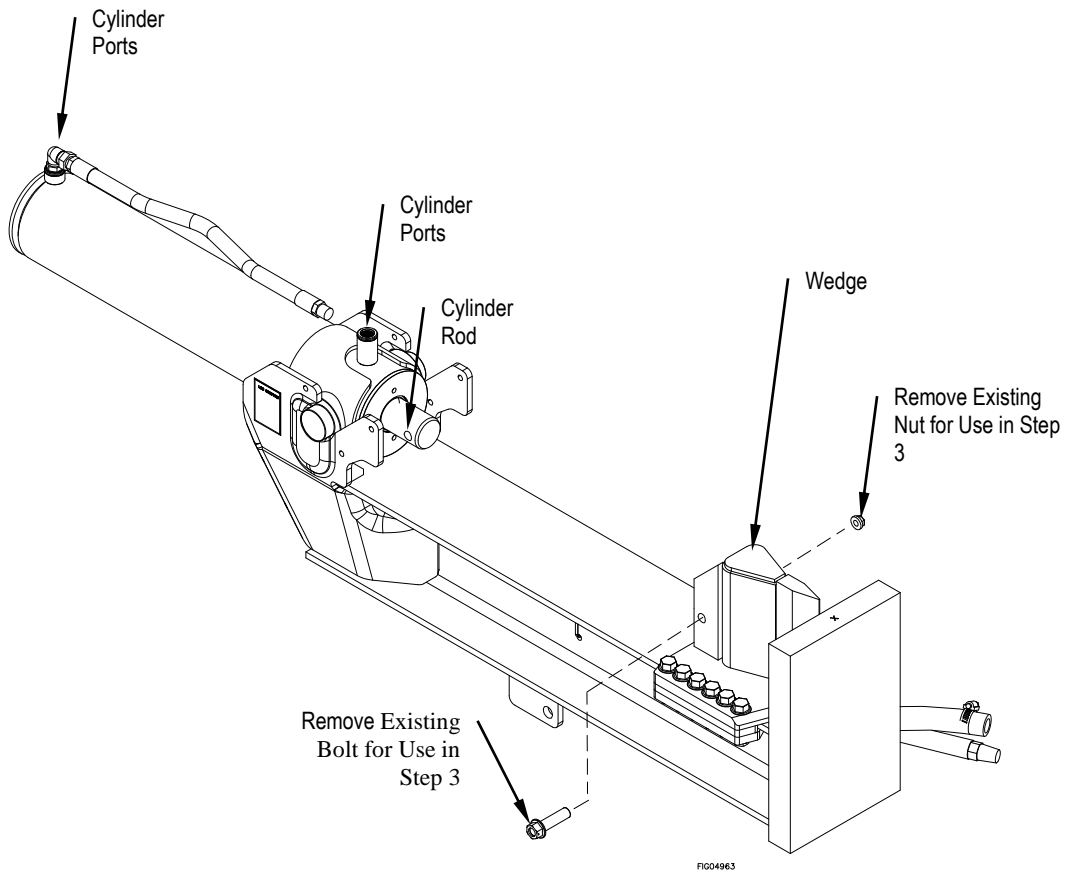

Assembly Instructions

Step 3 – Beam Assembly

- Align hole in wedge with the hole in the cylinder rod
- Install the existing bolt and nut to connect the wedge to the cylinder.
- Torque to 114 ft.-lb.

Tools Needed

- 22mm Wrench
(2 needed)

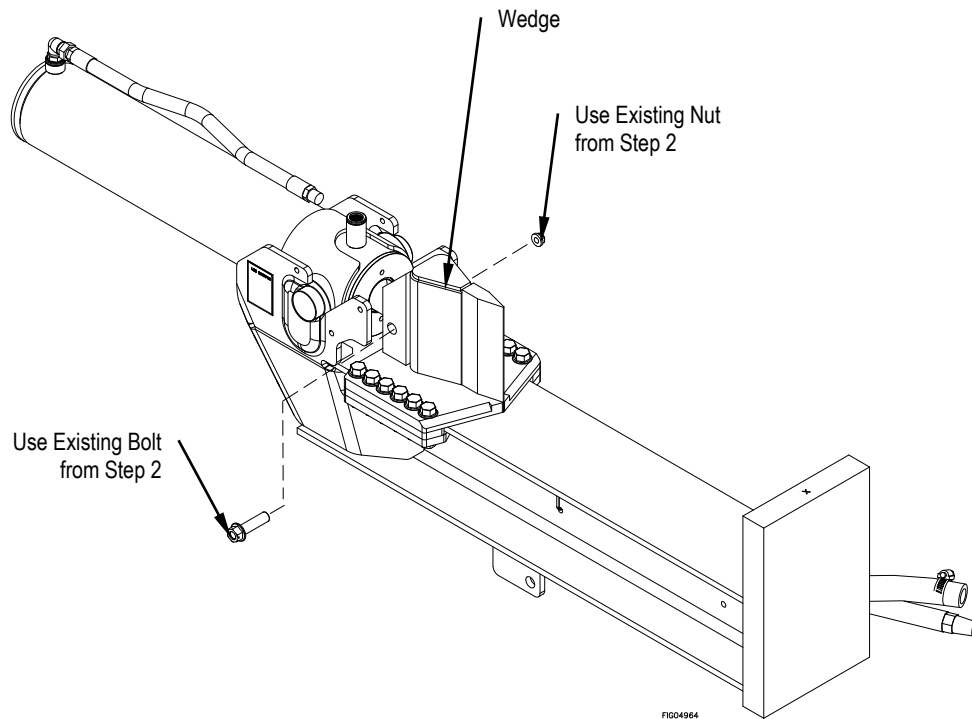

Assembly Instructions

Step 4 – Beam Assembly

- Align holes in the log stripper with the holes in the trunnion mount
- Attach the log stripper to beam using (6) nuts and (6) bolts.
- Torque to 21 ft.-lb.
- Remove the low pressure return hose and high pressure supply hose.
- Remove lag bolts (2) located inside trunnion mounts and stand assembled beam onto the end plate in the vertical position. Carefully move beam off to side, clear of work area.

Tools Needed

- 13mm Wrench

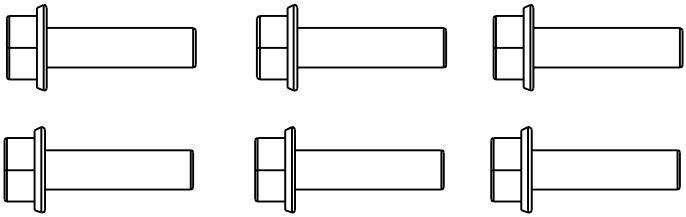

Log Stripper to Beam Bolt
Qty: 6

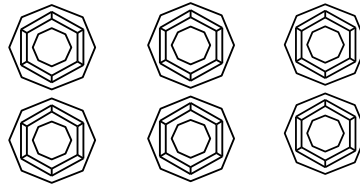

Log Stripper to Beam Nut
Qty: 6

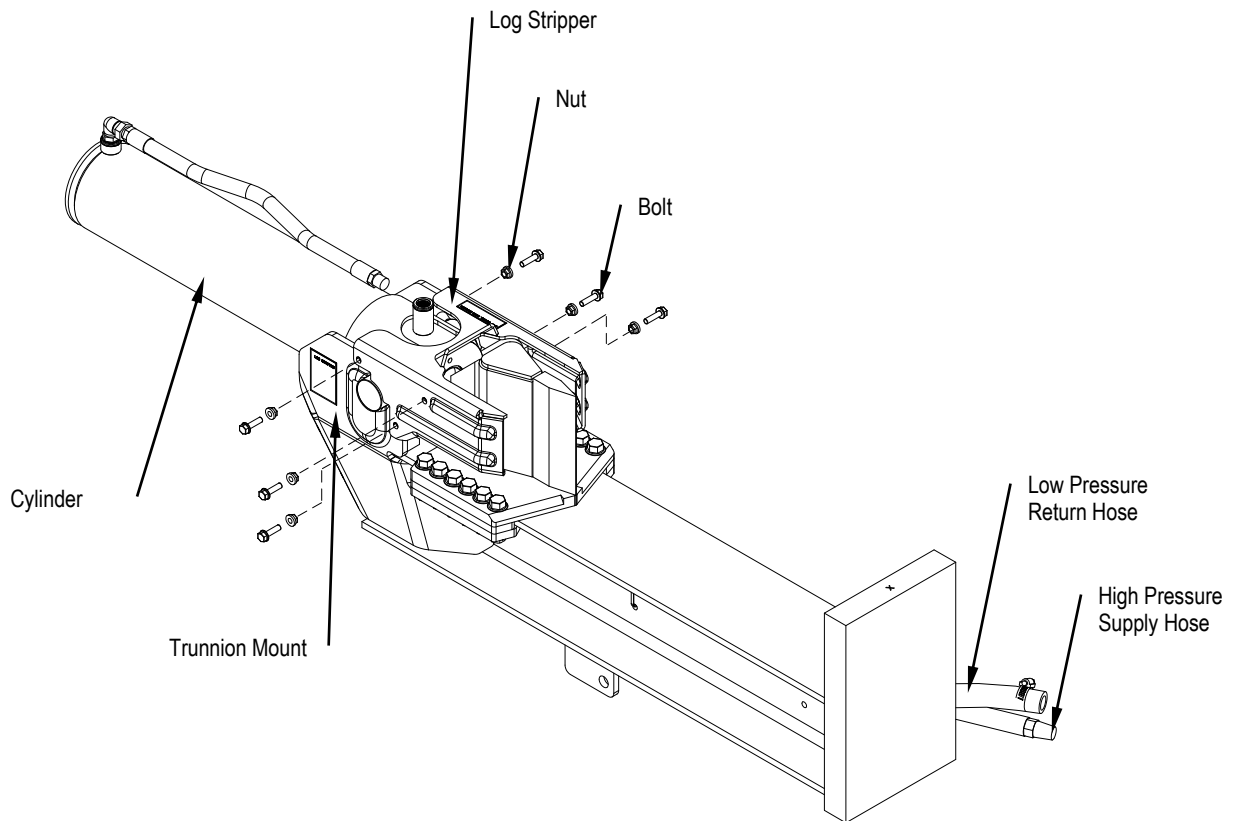

FIG04983

Assembly Instructions

Step 5 – Tank Weldment

- Screw finger-tight (1) Return Line Filter Head onto hydraulic tank return port.
NOTE: the arrow on filter head should point towards the tank.
- Wrench-tighten the fitting to 1.5-3.0 turns past “finger tight” position. Consider final orientation position as to not exceed the recommended TPFT. Properly assembled fittings total thread engagement should be 3.5-6 turns.
- **CAUTION:** Never back off an installed pipe fitting to achieve proper alignment. Loosening installed pipe fittings will corrupt the seal and contribute to leakage and failure.
- Screw finger-tight (1) Return Line Filter Canister onto bottom of return line filter head until gasket makes contact. Tighten filter an additional 1/2 turn.

Tools Needed

- Pipe Wrench
OR
- Crescent Wrench

Parts Needed from Manual Bag:

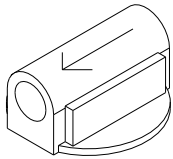

Return Line Filter Head
Qty: 1

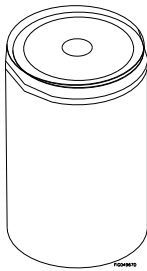

Return Line Filter Canister
Qty: 1

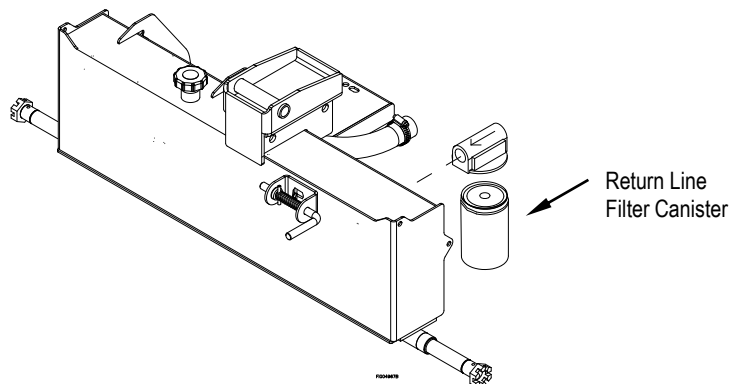
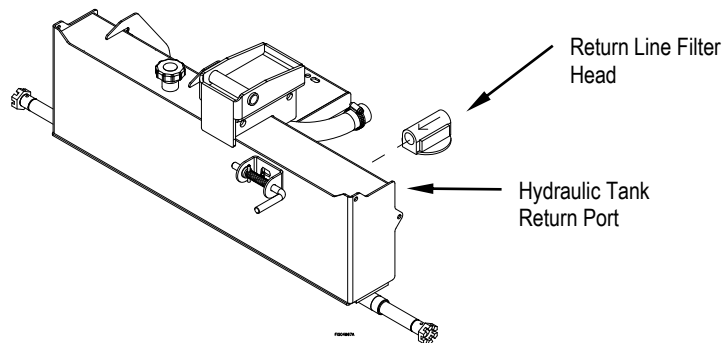

Assembly Instructions

Step 6 – Tank Weldment

- Remove axle nuts from axles

Tools Needed

- None

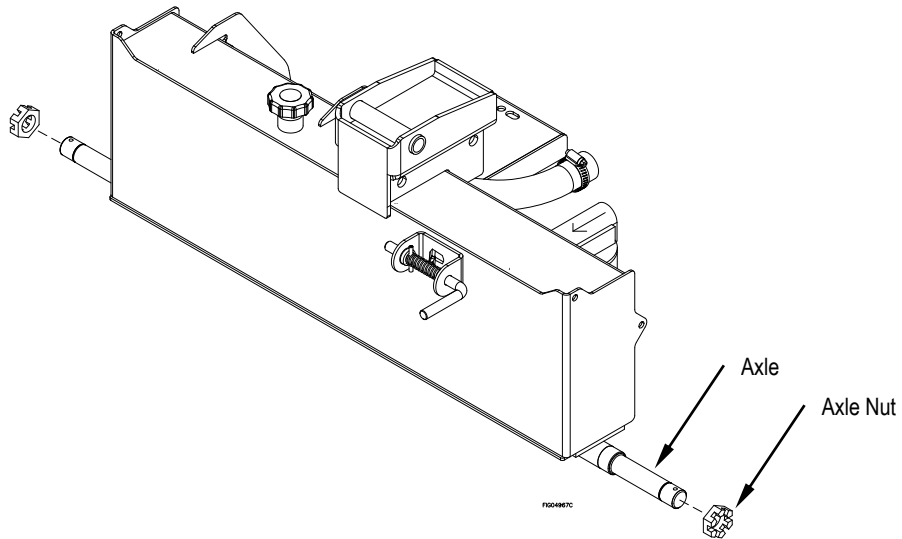

Assembly Instructions

Step 7 – Tank Weldment

- Slide tire onto axle with valve stem facing out
- Slide wheel washer up against the wheel bearing
- Using a torque wrench, tighten the axle nut to 30-40 ft.-lb.
Turn hub to ensure proper bearing seating.
- Loosen the axle nut until loose enough to turn the axle nut with your fingers.
- Re-tighten the axle nut until “finger tight”.
- Insert cotter pin through hole in axle nut and axle. Bend and spread prongs in opposite directions so the axle nut will not come off (make sure the tire spins freely)

Tools Needed

- Pliers

Fasteners Needed from Parts Bag:

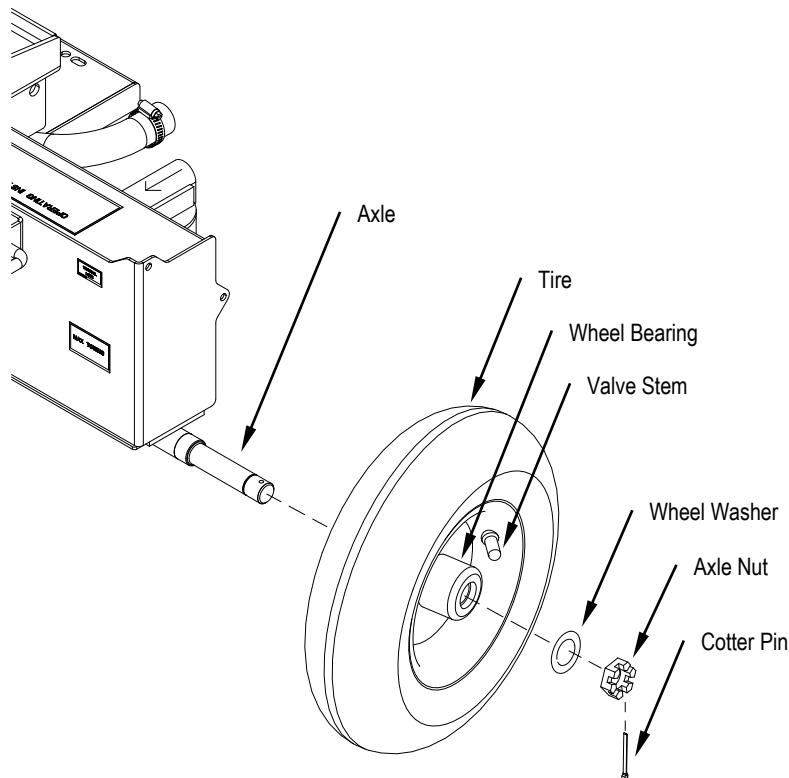
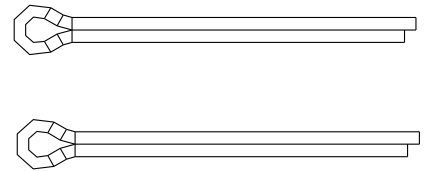
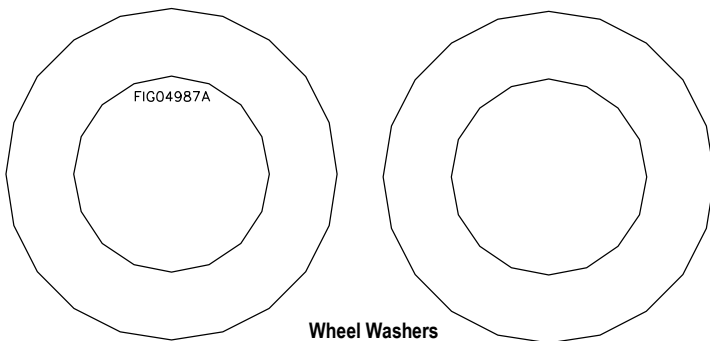

FIG04988A

Assembly Instructions

Step 8 – Tank Weldment

- Align the dust cap against the wheel hub
- Position the dust cap tool evenly onto the surface of the dust cap
- Place a piece of wood over the dust cap tool
- Using a soft faced mallet tap the piece of wood against the dust cap tool to install dust cap onto the wheel hub
- Repeat Steps 7 & Step 8 for the other wheel. Discard hub cap tool.

Tools Needed

- Soft Faced Mallet

Fasteners Needed from Parts Bag:

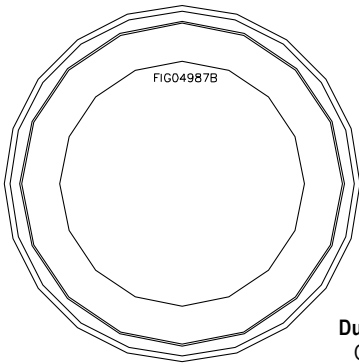

Dust Cap
Qty: 2

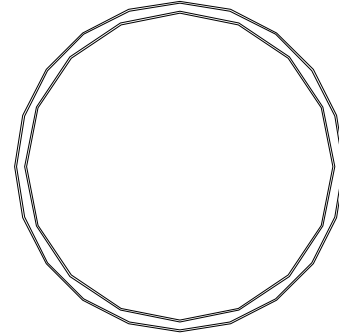
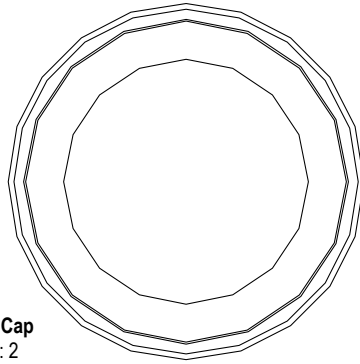

Dust Cap Tool
Qty: 1

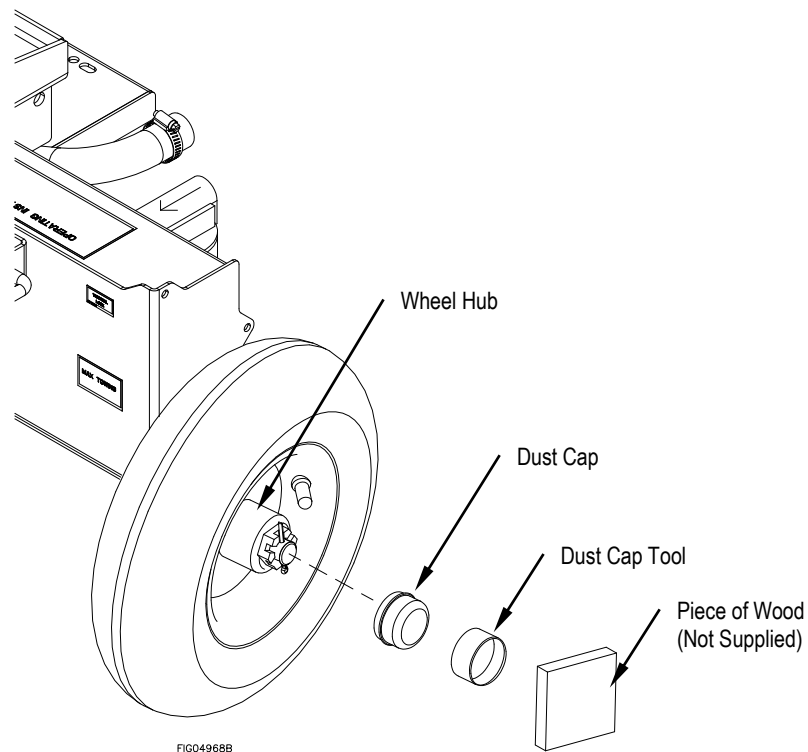

Assembly Instructions

Step 9 – Coupler Assembly

- Place tow bar on level surface as shown below.
- Insert (2) tow bar spacers into tow bar. Align with bolt holes.
- Place coupler on to tow bar and align with holes used to align spacers.
- Secure coupler and tow bar spacers using (2) nuts and (2) bolts.
- Torque to 71 ft.-lb.

Tools Needed

- 18mm Wrench
(2 Needed)

Fasteners Needed from Parts Bag:

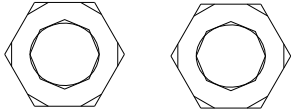

Coupler to Tow Bar Nut
Qty: 2

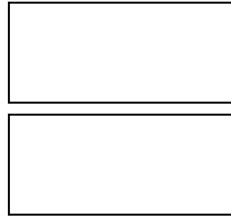

Tow Bar Spacer
Qty: 2

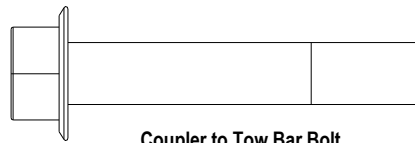

Coupler to Tow Bar Bolt
Qty: 2

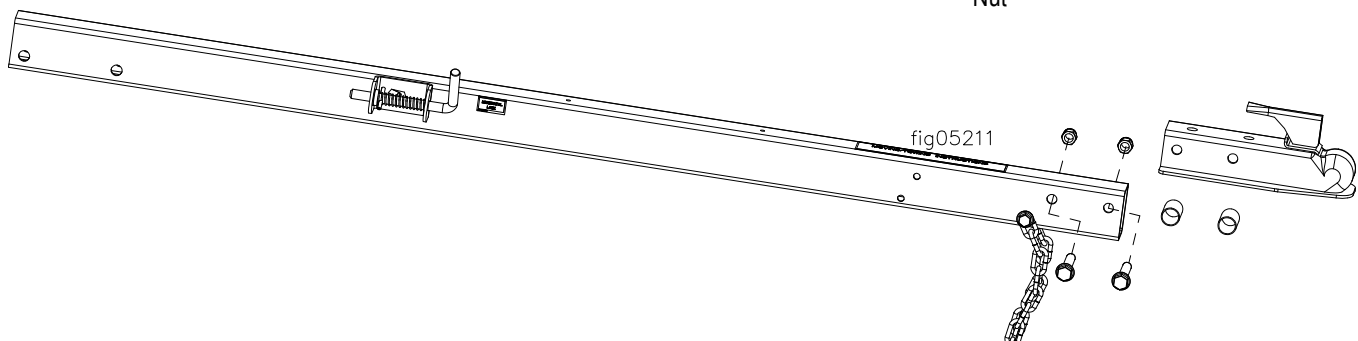
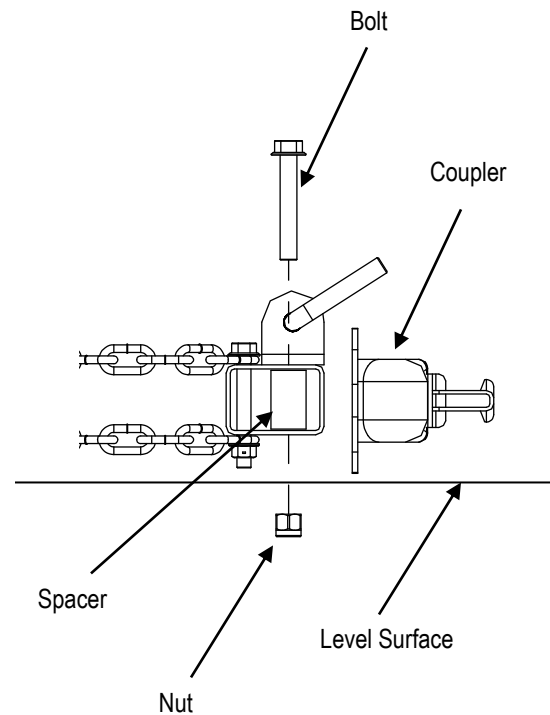

Assembly Instructions

Step 10 – Tow Bar Assembly

- Insert tow bar into the tank pivot mount.
- Align holes in tow bar with holes in tank pivot mount.
- Connect the towbar to the tank using (2) Tow Bar Bolts and (2) Tow Bar Locknuts
- Torque to 71 ft.-lb.

Tools Needed

- 18mm Wrench
(2 Needed)

Fasteners Needed from Parts Bag:

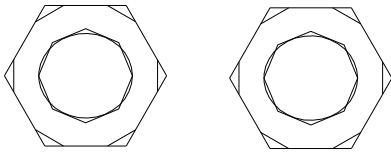

Tow Bar to Tank Nut
Qty: 2

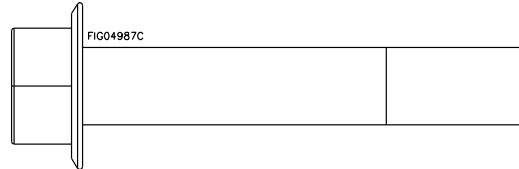

Tow Bar to Tank Bolt
Qty: 2

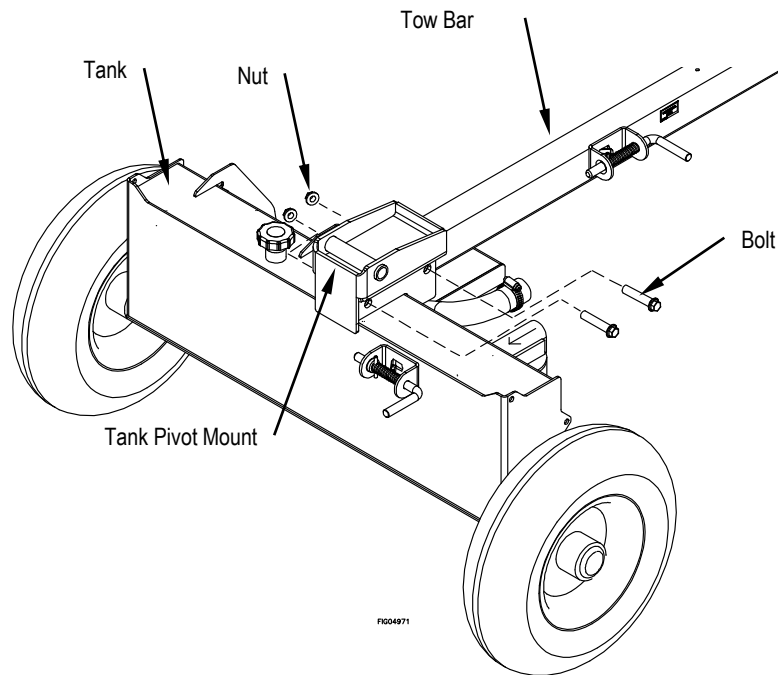

Assembly Instructions

Step 11 – Tow Bar Assembly

- Remove existing support leg bolt, washer, nut and catch pin from support leg.
- Position the support leg to the front of the tow bar.
- Insert catch pin to lock support leg in vertical position.
- Secure leg using existing support leg bolt, washer and nut.
- Tighten nut until snug then back off 1/2 turn.

Tools Needed

- 13mm Wrench
(2 needed)

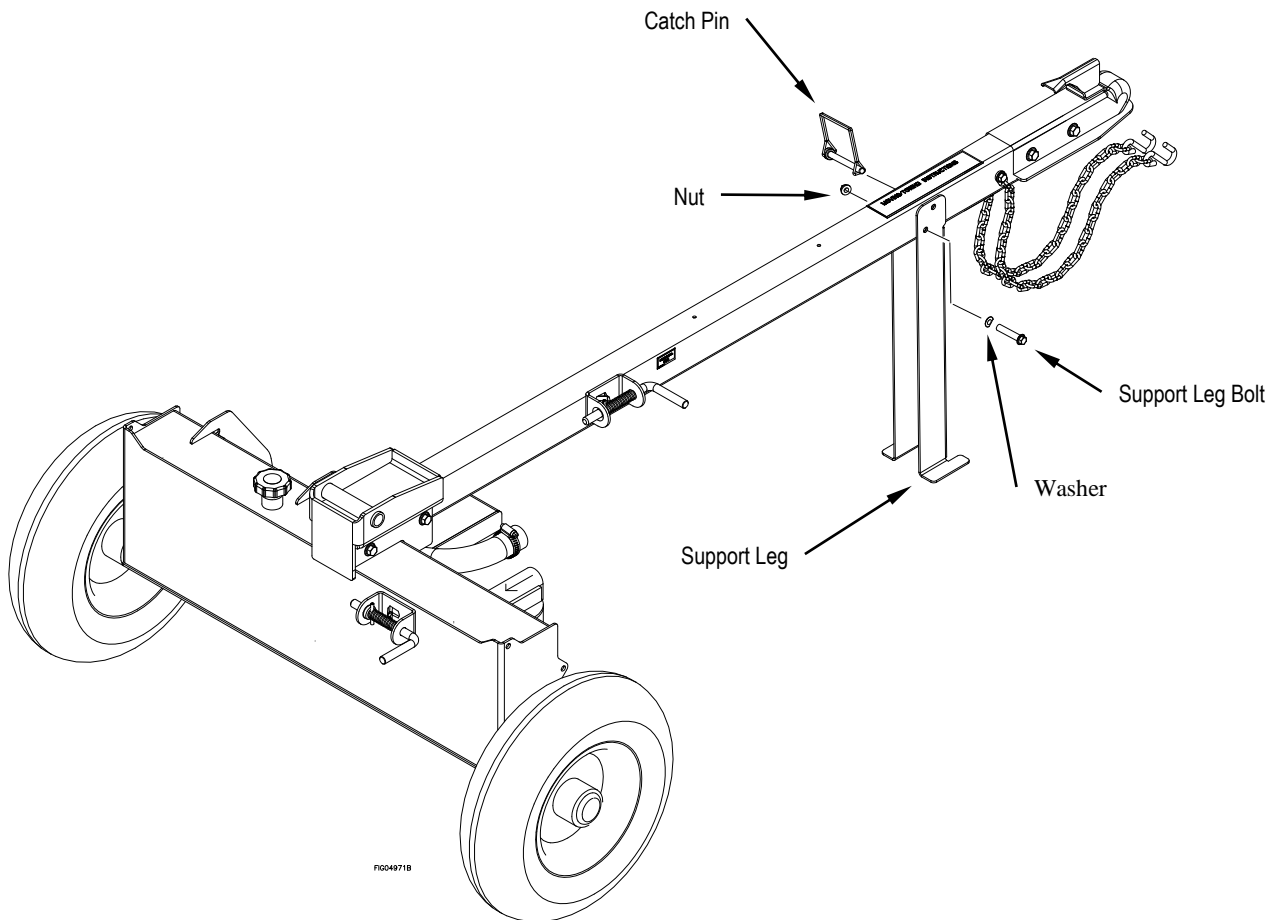

Assembly Instructions

Step 12 – Engine

- Install Engine/Pump Assembly using engine mounting pattern shown below.
- Install Engine/Pump Assembly to tank mount plate using (4) 1169 Engine Bolts and (4) 1169 Engine Flange Nuts
- Torque to 41 ft.-lb.

Tools Needed

- 16mm Wrench

Fasteners Needed from Parts Bag:

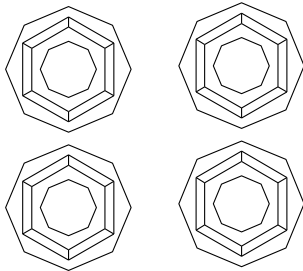

Engine to Tank Nut (1169)
Qty: 4

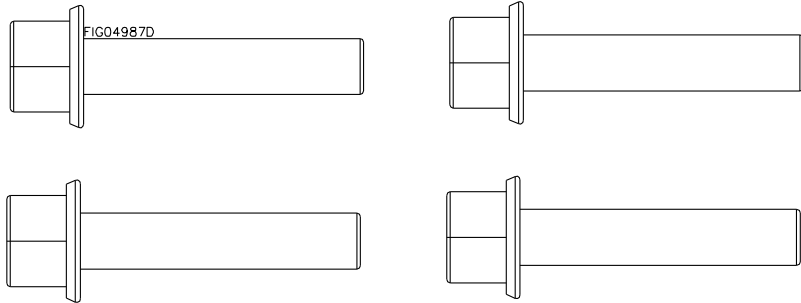

Engine to Tank Bolt (1169)
Qty: 4

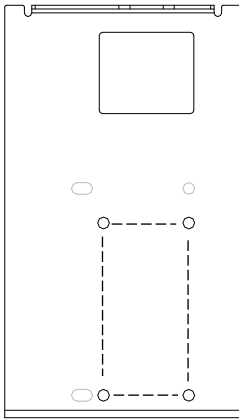

Engine Mounting Pattern



Assembly Instructions

Step 13 – Beam to Tank

- Stand assembled beam onto the end plate in the vertical position.
- Orient the beam assembly and tank weldment as shown. Make sure a helper holds onto the top of the beam assembly during the remainder of this step. The beam is very heavy and dangerous if it tips over
- Align the pivot bracket on beam assembly to the pivot mount on the tank weldment and insert (1) beam pivot pin
- Insert (1) cotter pin through hole in beam pivot pin and spread and bend prongs in opposite directions to secure

Tools Needed

- Pliers

Fasteners Needed from Parts Bag:

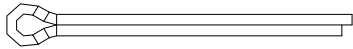

Cotter Pin
Qty: 1

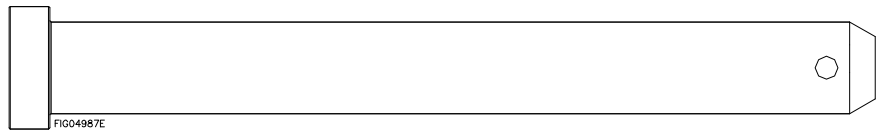

Beam Pivot Pin
Qty: 1

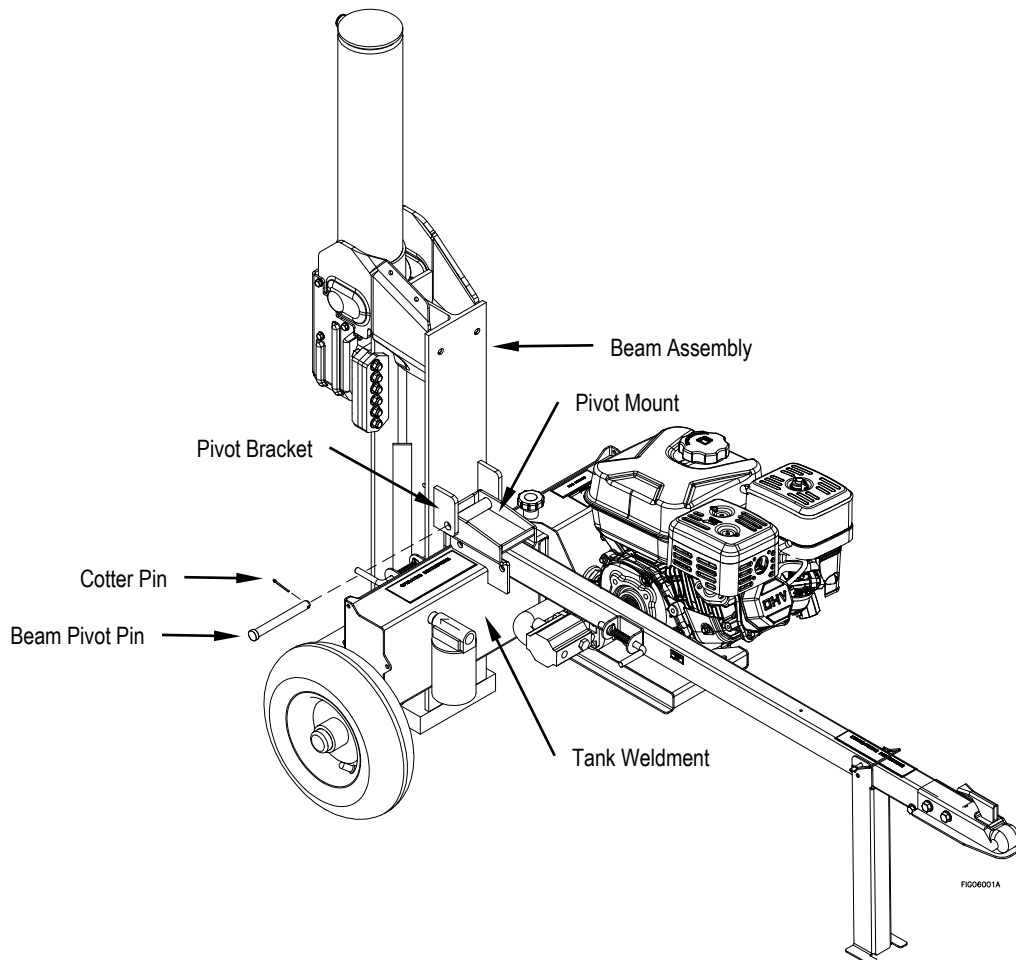

Assembly Instructions

Step 14 – Beam to Tank

- Install the horizontal beam lock to the beam assembly using (2) Beam Lock Bolts and (2) Beam Lock Flange Nuts
- Torque to 71 ft.-lb.

Tools Needed

- 18mm Wrench

Fasteners Needed from Parts Bag:

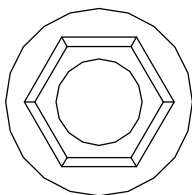

Horz. Latch to Beam Nut
Qty: 2

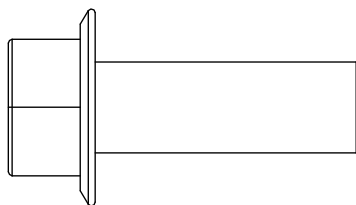
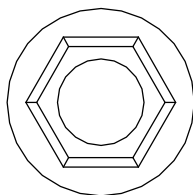

Horz. Latch to Beam Bolt
Qty: 2

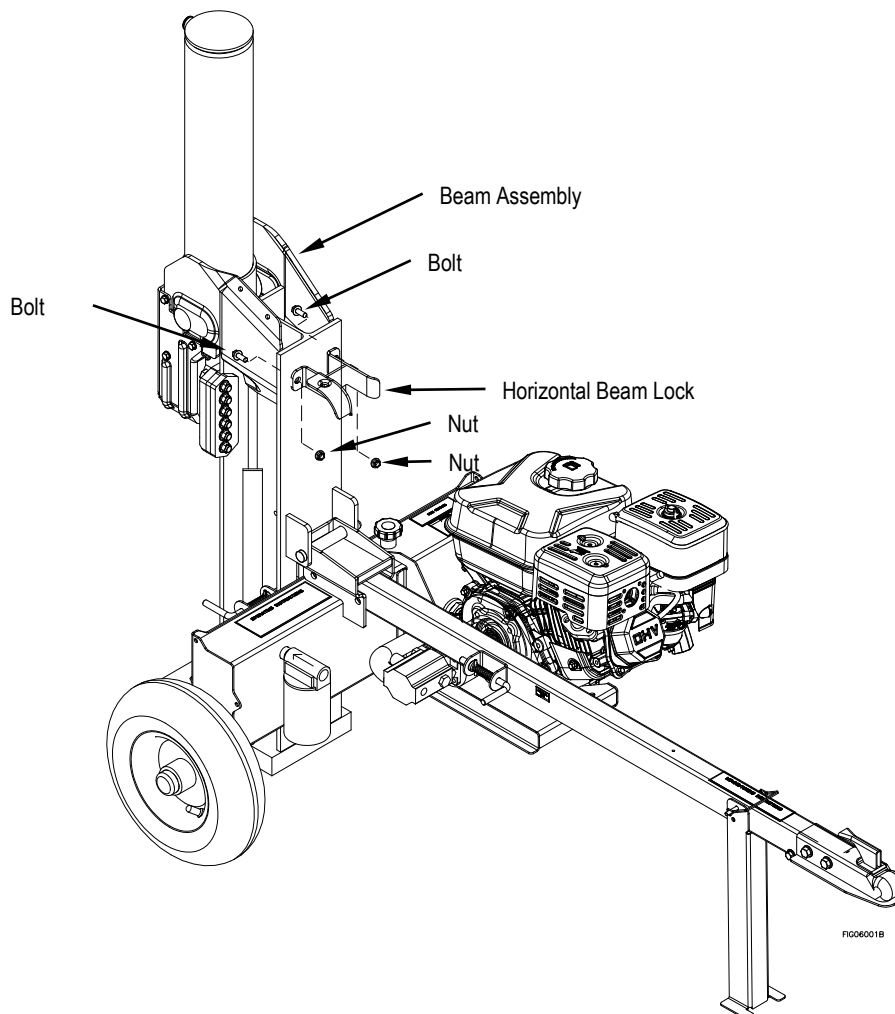
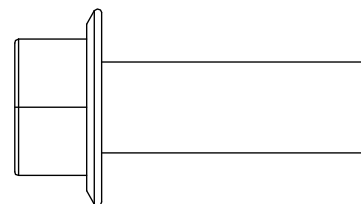

Assembly Instructions

Step 15 – Control Valve

- Slide control valve handle into the clevis slots on the control valve.
- Align holes in handle with clevis holes.
- Insert the supplied pins through holes and secure with supplied bridge clips.

Tools Needed

- Pliers

Parts Needed from Parts Bag:

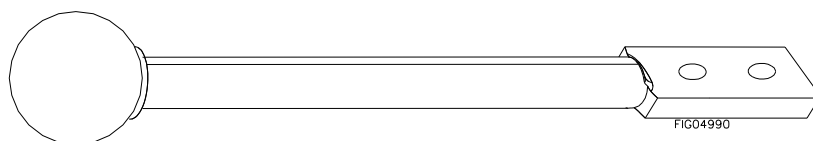

Control Valve Handle
Qty: 1



Bridge Clip
Qty: 2

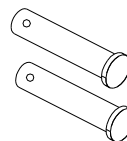

Pin
Qty: 2

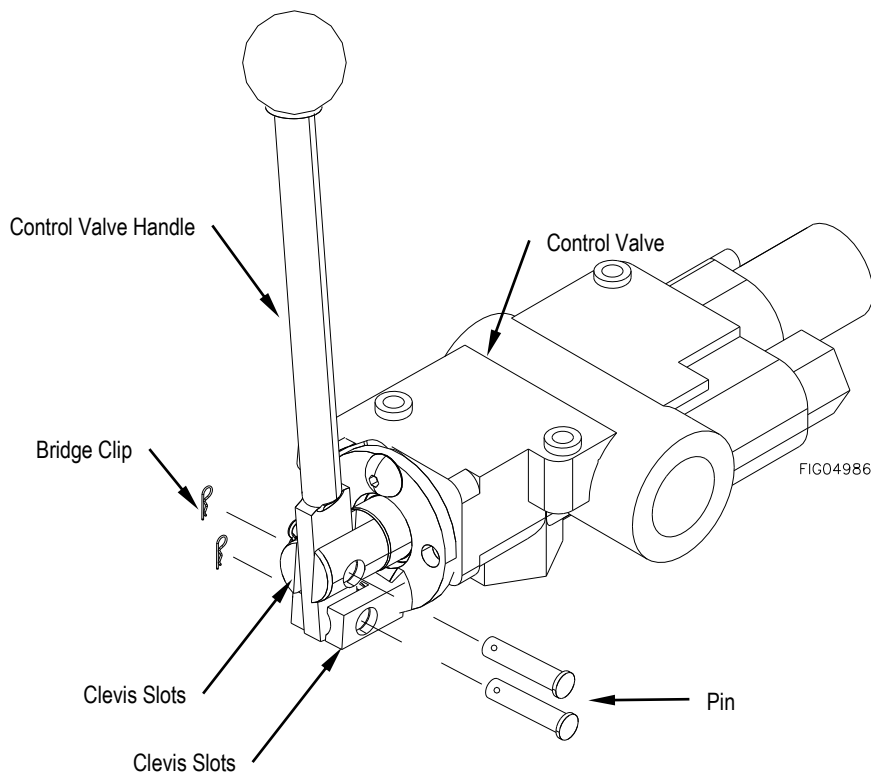

Assembly Instructions

Step 16 -Fittings

- Lubricate O-ring and threads on fitting with clean oil
- Orientate (1) Valve Fitting so that nut/washer/O-ring assembly is facing up. Turn fitting into cylinder port until finger-tight
- Torque to 37-46 ft.-lb.
- Looking at fitting from end with nut/washer O-ring assembly, turn nut clockwise as far as possible
- Use valve port marked "A " to thread the control valve onto the fitting until control valve touches washer
- Hold control valve in orientation shown below and torque nut to 37-46 ft.-lb.

Tools Needed

- 7/8" Wrench (2 needed)
OR
- Crescent Wrench (2 needed)

Fastener Needed from Parts Bag:

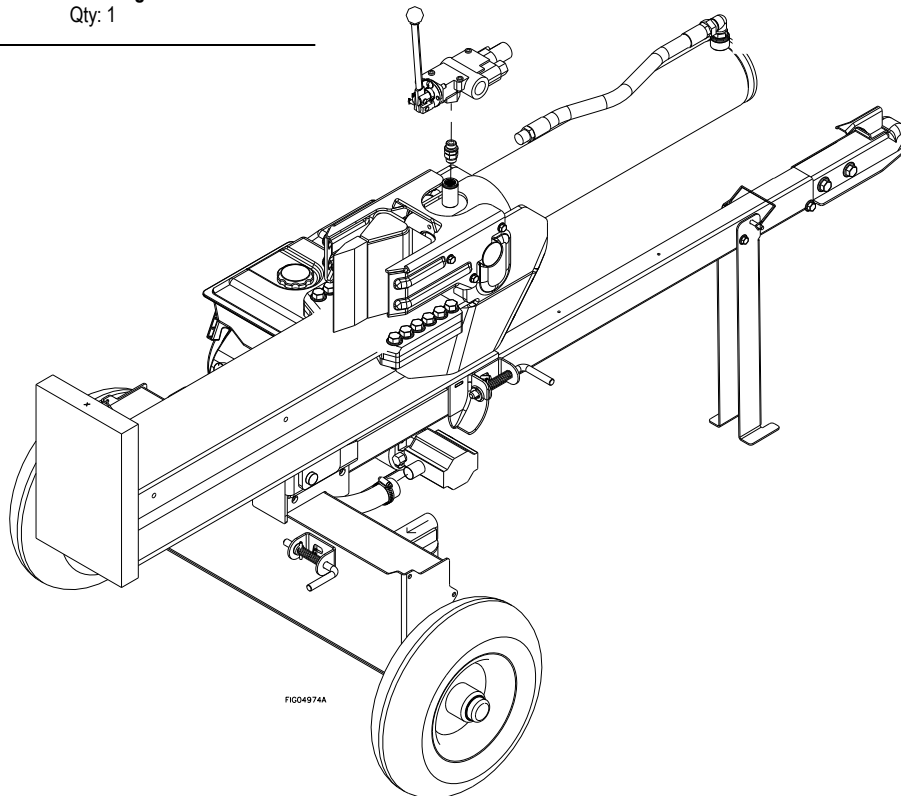
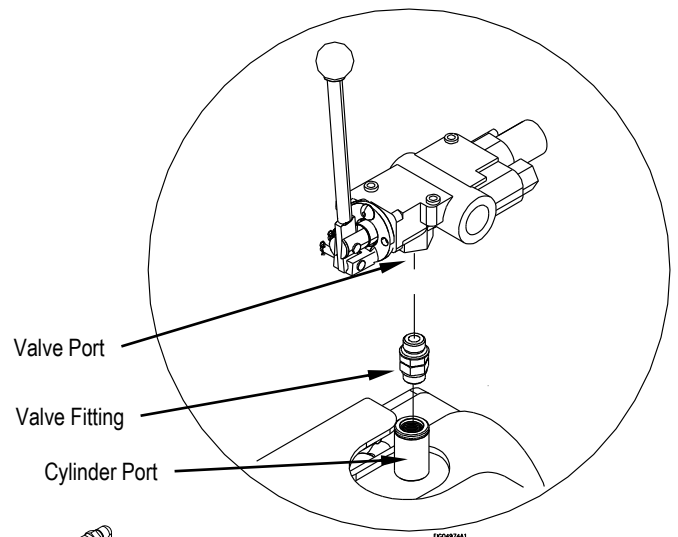
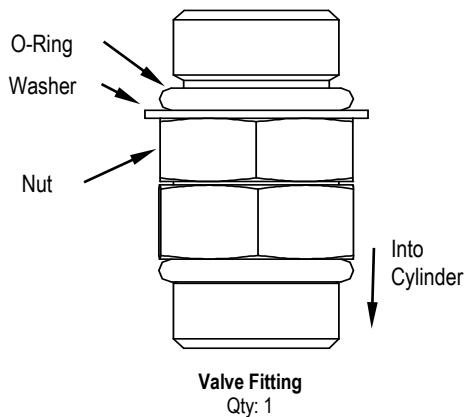

Assembly Instructions

Step 17 - Fittings

- Lubricate O-ring and threads on fitting with clean oil
- Looking at fitting from end with nut/washer/O-ring assembly, turn nut clockwise as far as possible
- Using wrench, turn (1) Small Swivel Fitting into valve port marked "B" until washer touches control valve. Continue turning until washer touches thread nearest wrench pad
- Back off fitting counterclockwise not exceeding one revolution until it is oriented in the correct position
- Place wrench on the wrench pad of fitting to prevent fitting from turning and torque nut to 37-46 ft.-lb.
- Thread Small Swivel Fitting nut onto Cylinder Hose until hand tight.
- Wrench tighten 2-3 Turns past Finger Tight

Tools Needed

- 7/8" Wrench
- 3/4" Wrench
- 1" Wrench
OR
- Crescent Wrench
(2 needed)

Fastener Needed from Parts Bag:

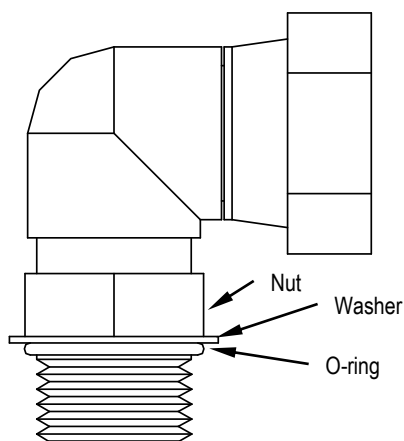

Small Swivel Fitting
Qty: 1

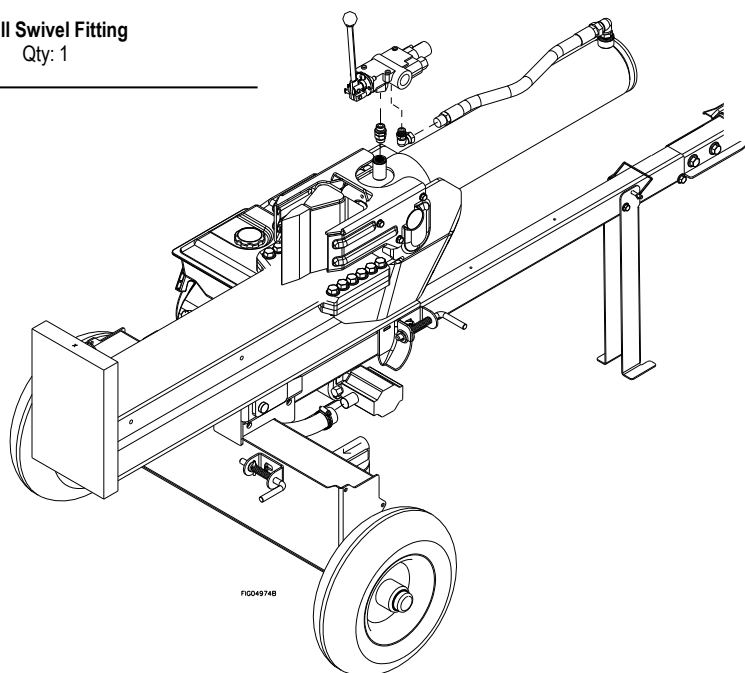
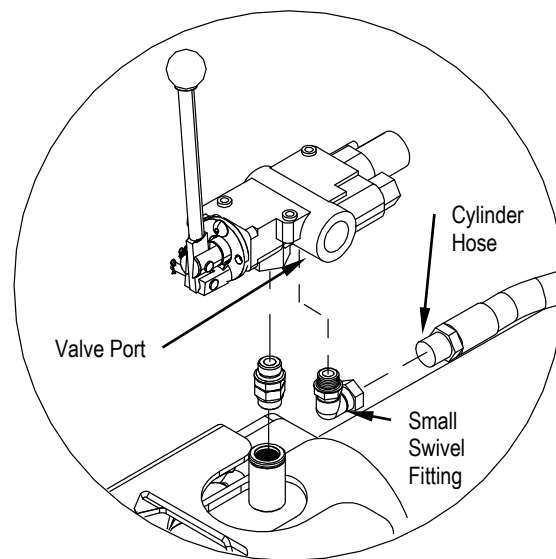

Assembly Instructions

Step 18 - Fittings

- Lubricate O-ring and threads on fitting with clean oil
- Looking at fitting from end with nut/washer/O-ring assembly, turn nut clockwise as far as possible
- Using wrench, turn (1) Large Swivel Fitting into the valve port marked "In" until washer touches control valve. Continue turning until washer touches thread nearest wrench pad
- Back off fitting counterclockwise not exceeding one revolution until it is orientated in the correct position
- Place wrench on the wrench pad of fitting to prevent fitting from turning and torque nut to 70-87 ft.-lb.

Tools Needed

- 1 1/4" Wrench
- 1 1/16" Wrench
- OR
- Crescent Wrench (2 Needed)

Fasteners Needed from Parts Bag:

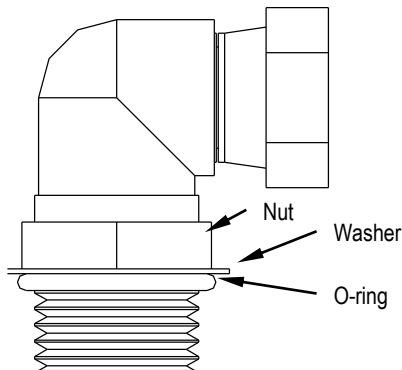

Large Swivel Fitting
Qty: 1

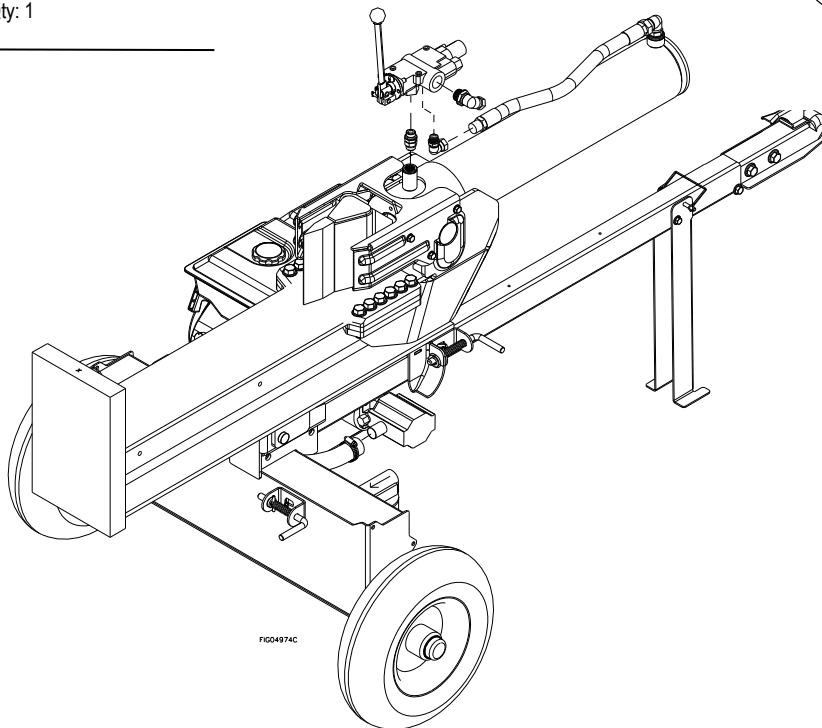
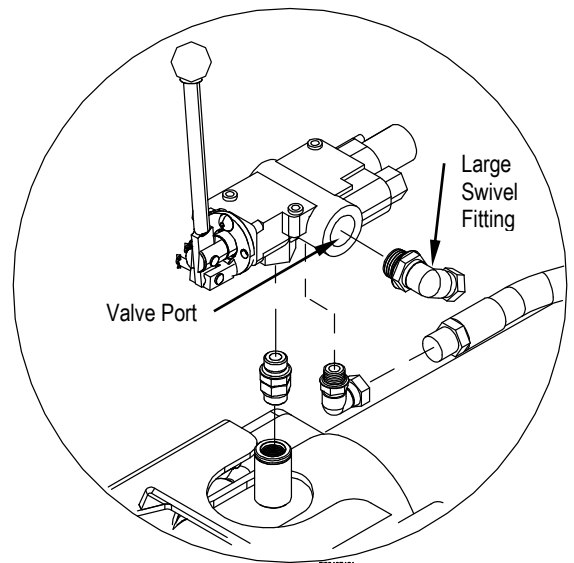

Assembly Instructions

Step 19 - Fittings

- Lubricate O-ring and threads on fitting with clean oil
- Looking at fitting from end with nut/washer/O-ring assembly, turn nut clockwise as far as possible
- Using wrench, turn (1) Hose Barb Fitting into the valve port marked "Out" until washer touches control valve. Continue turning until washer touches thread nearest wrench pad
- Back off fitting counterclockwise not exceeding one revolution until it is orientated in the correct position
- Place wrench on the wrench pad of fitting to prevent fitting from turning and torque nut to 70-87 ft.-lb.

Tools Needed

- 1 1/16" Wrench
- 1 1/4" Wrench
OR
- Crescent Wrench
(2 Needed)

Fasteners Needed from Parts Bag:

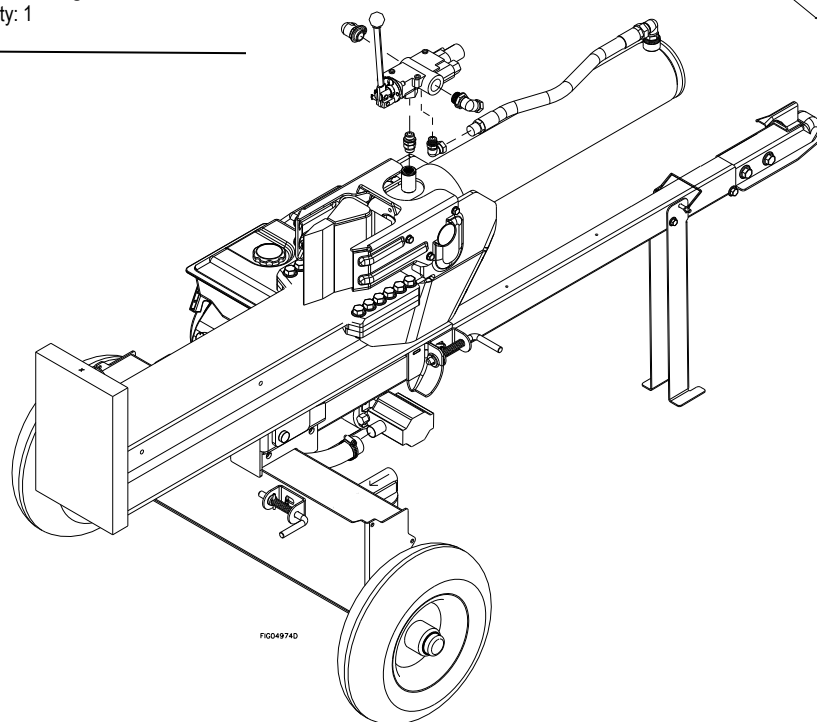
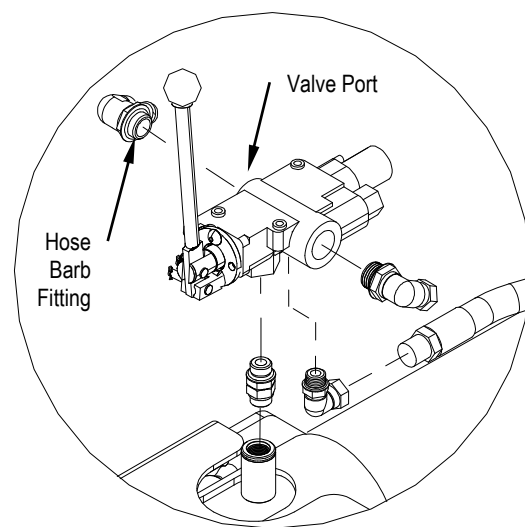
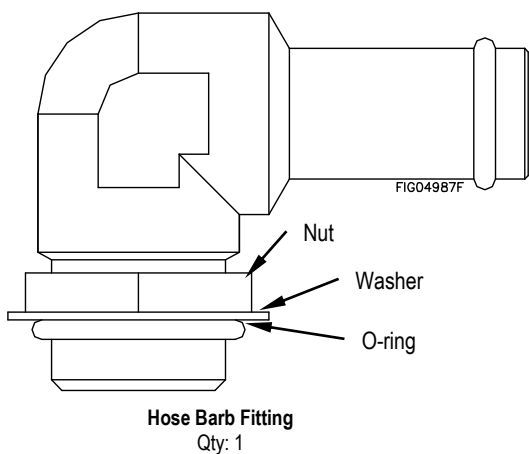

Assembly Instructions

Step 20 - Fittings

- Screw finger-tight (1) Return Line Fitting into the return line filter head
- Wrench-tighten the fitting to 1.5-3.0 turns past “finger tight” position. Consider final orientation position as to not exceed the recommended TPFT. Properly assembled fittings total thread engagement should be 3.5-6 turns
- **CAUTION:** Never back off an installed pipe fitting to achieve proper alignment. Loosening installed pipe fittings will corrupt the seal and contribute to leakage and failure.
- Connect the end of the suction hose to the pump inlet.
- Secure the low pressure return hose to return line fitting with supplied hose clamp installed on hose. Torque to 77 in.-lb.

Tools Needed

- Flat Blade Screw Driver
- Crescent Wrench
- OR
- 1 1/16” Wrench

Fasteners Needed from Parts Bag:

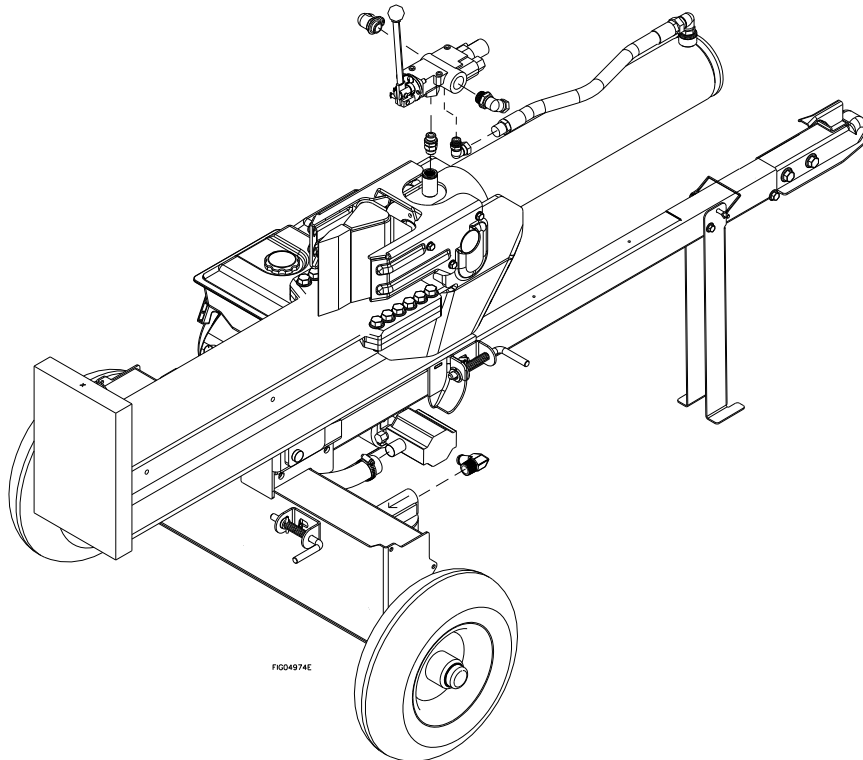
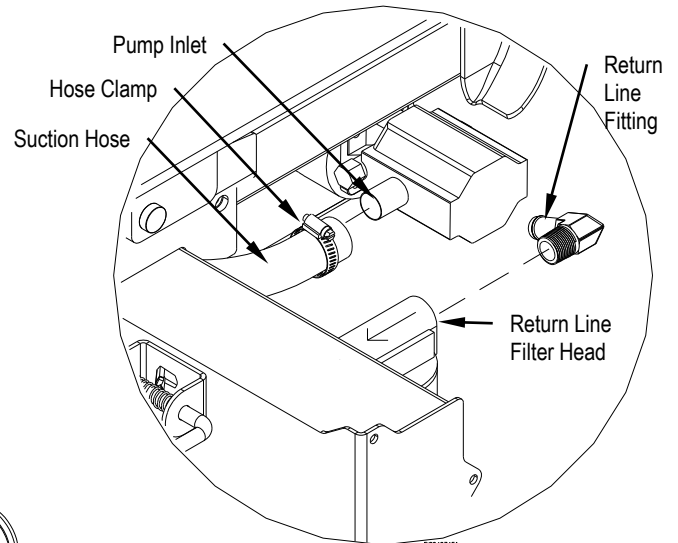
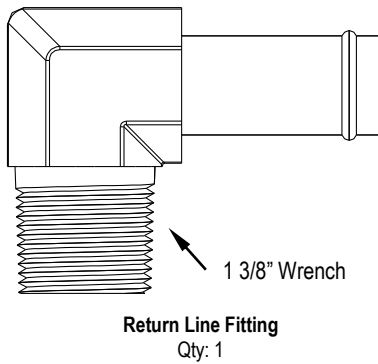

Assembly Instructions

Step 21A – Low Pressure Return Hose

- Route the low pressure return hose from the valve outlet fitting down to the return line filter fitting
- Secure the low pressure return hose to return line fitting with supplied hose clamp installed on hose. Torque to 77 in.-lb.
- Secure the remaining end of the low pressure return hose to valve outlet fitting located on the control valve with supplied hose clamp installed on hose. Torque to 77 in.-lb.

Tools Needed

- 8mm Socket Wrench

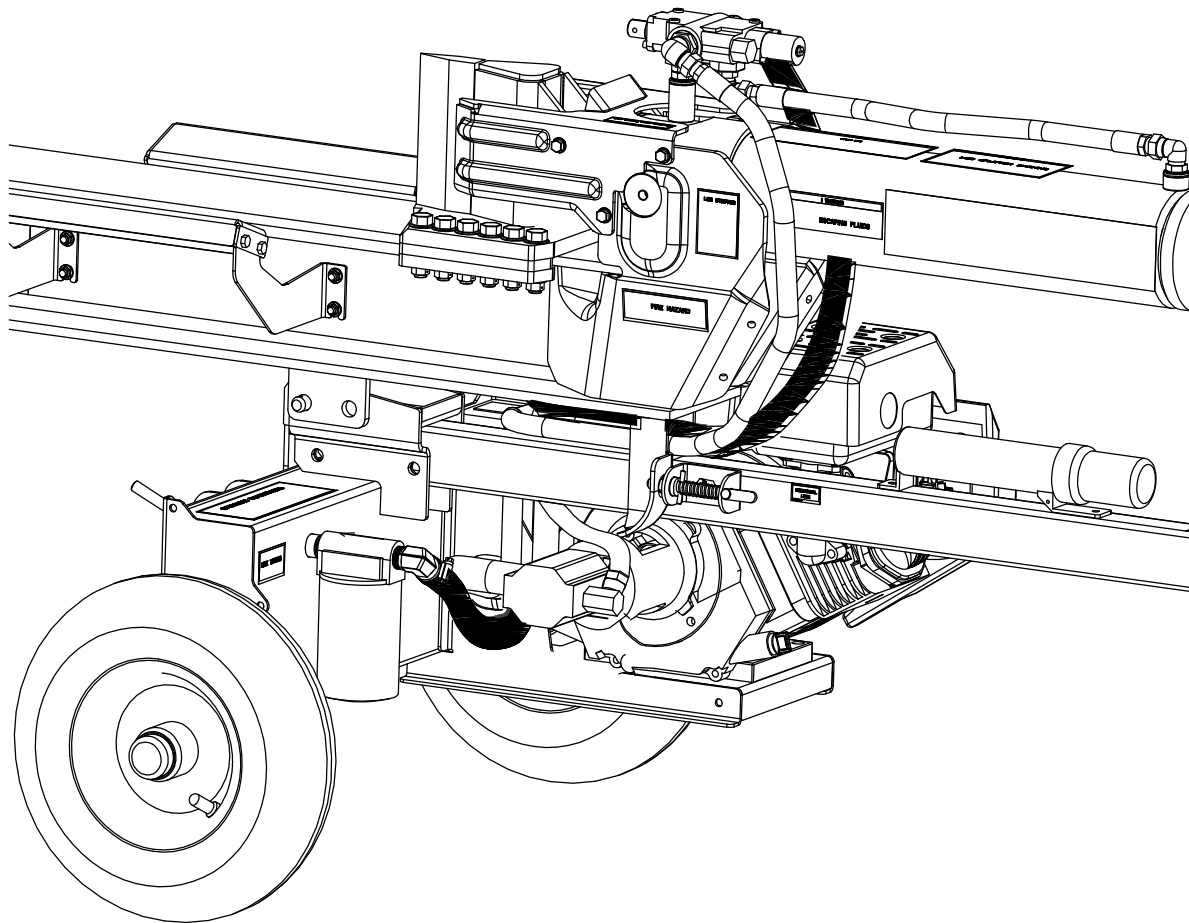
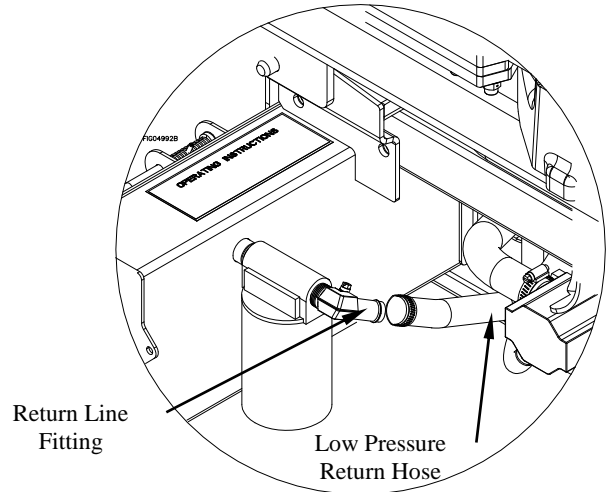
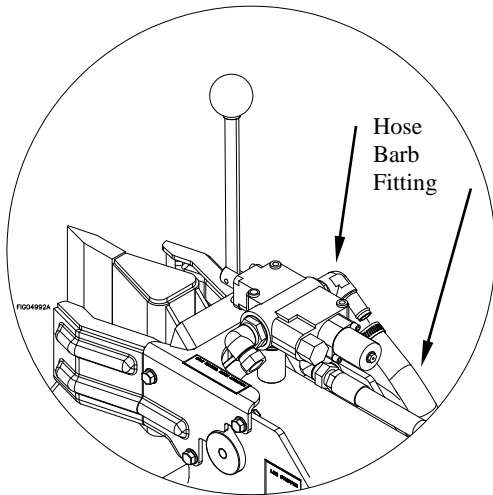

Assembly Instructions

Step 21B – High Pressure Supply Hose

- Route the High-Pressure Supply Hose from the high pressure fitting on the pump up to the Large Swivel Fitting on the control valve inlet.
- Screw finger-tight High-Pressure Supply Hose to the high pressure fitting on the pump outlet.
- Wrench tighten 1.5-3.0 turns past “finger tight”
- Screw finger-tight remaining end of the High-Pressure Supply Hose to the Large Swivel Fitting on the control valve inlet.
- Wrench tighten 1.5-3.0 turns past “finger tight”

Tools Needed

- 1” Wrench
- 7/8” Wrench
- OR
- Crescent Wrench (2 Needed)

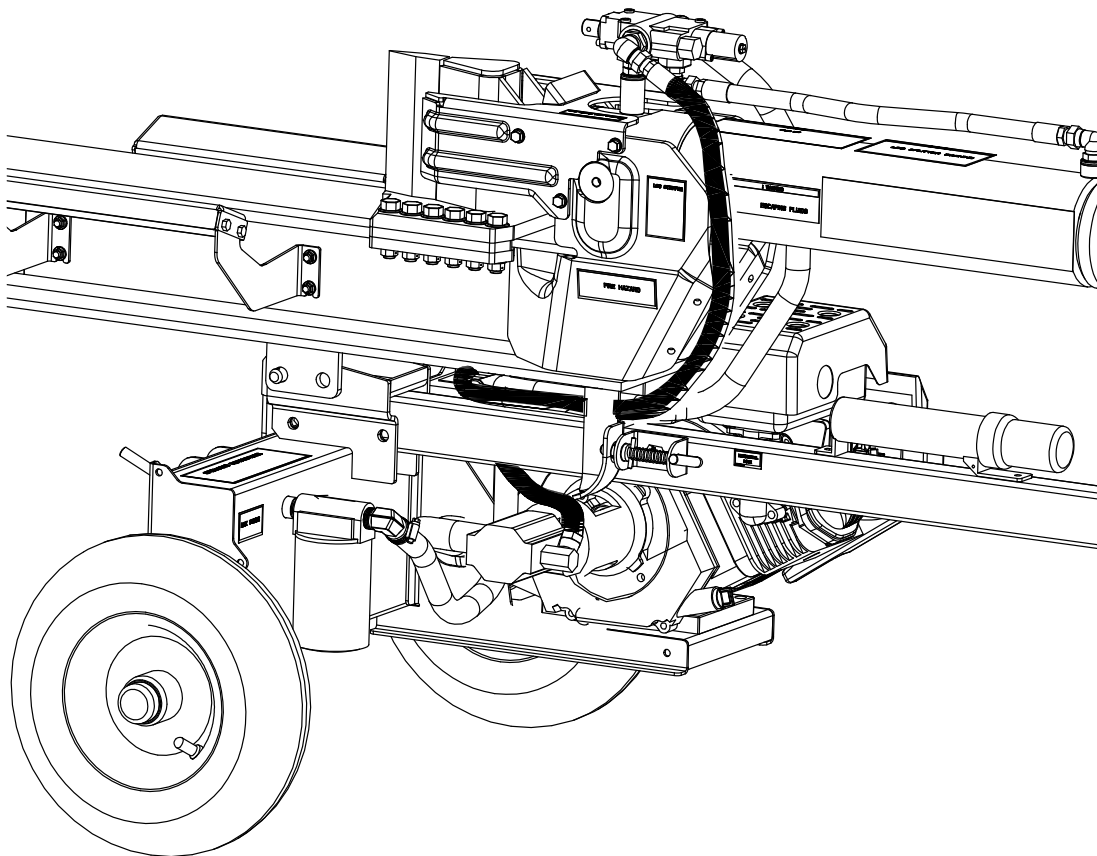
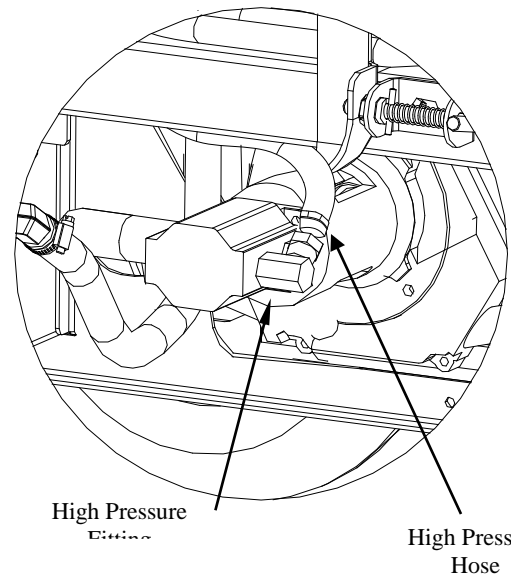
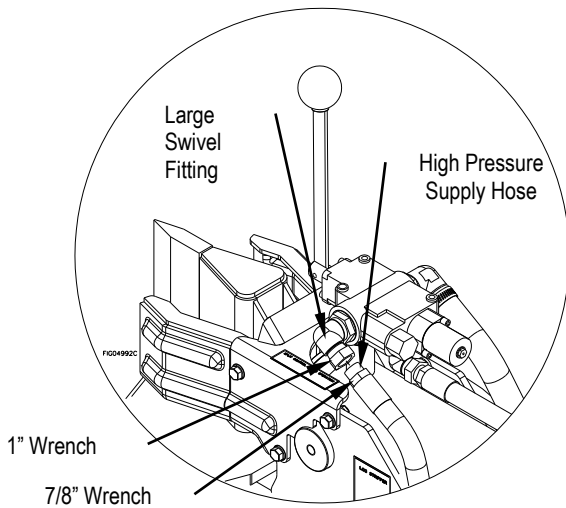

Assembly Instructions

Step 22 – Zip Ties

- Route zip tie through hole in trunnion mount and around hose.
- Tighten zip tie and cut off excess length.
- Repeat for remaining three holes in trunnion mounts.

Tools Needed

- Wire Cutter

Fasteners Needed from Parts Bag:

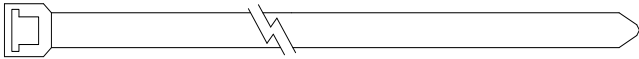

Small Zip Tie
Qty: 4

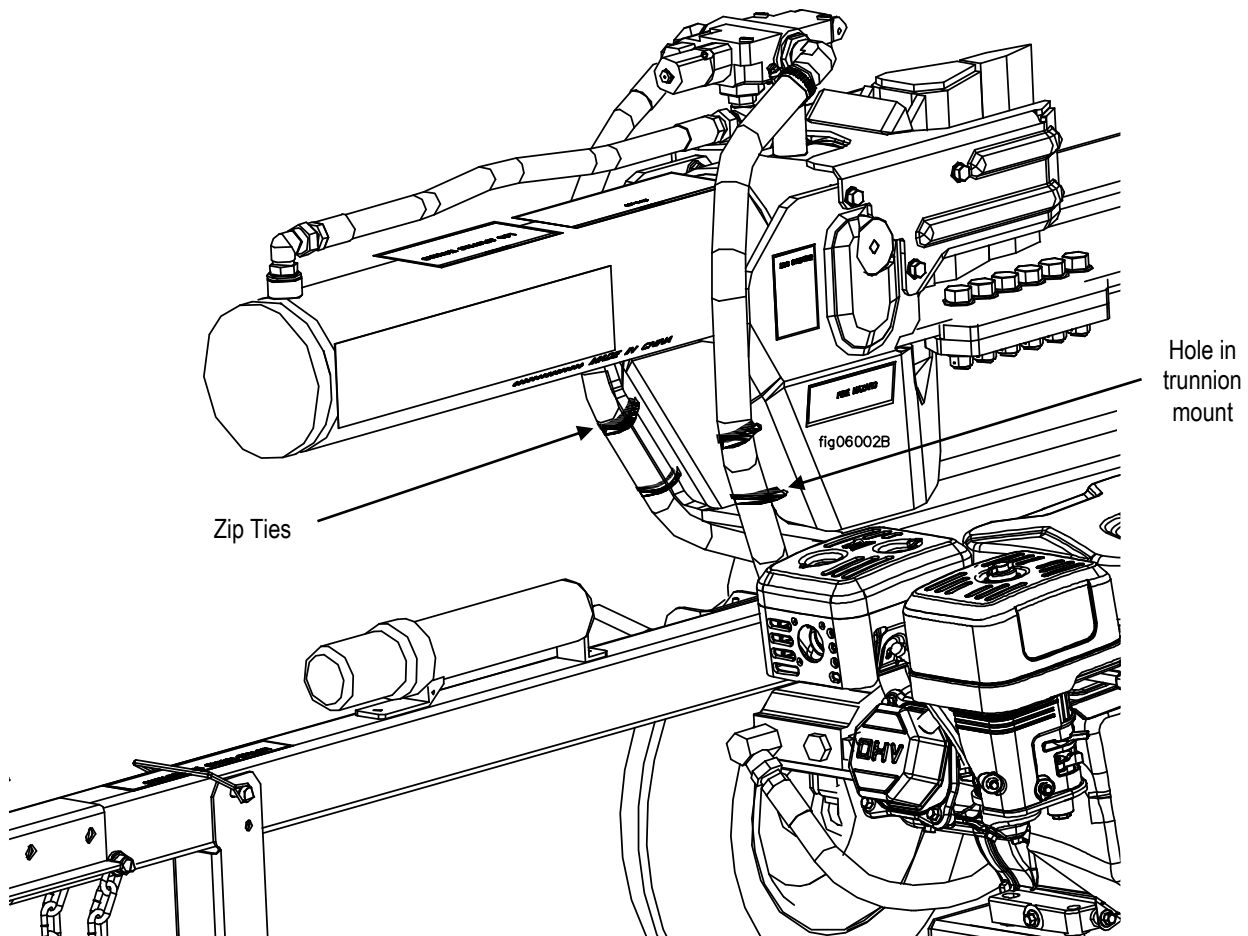

Assembly Instructions

Step 22 – Zip Ties Continued

- Route zip tie around high and low pressure hoses as shown below.
- Tighten zip tie and cut off excess length.

Tools Needed

- Wire Cutter

Fasteners Needed from Parts Bag:



Large Zip Tie
Qty: 1

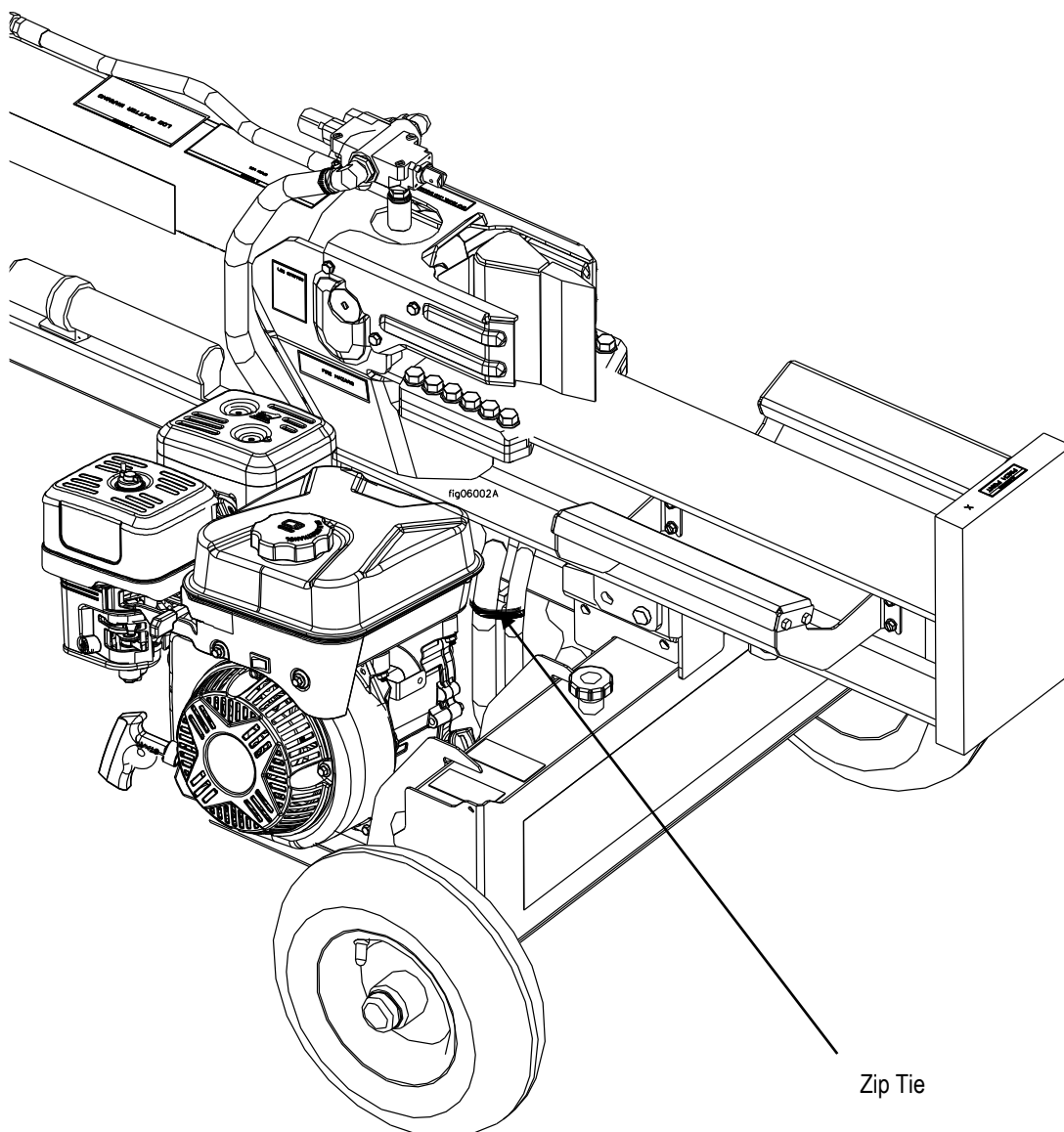

Zip Tie

Assembly Instructions

Step 23 – Manual Tube

- Remove the manual tube cover from manual tube
- Align holes in manual tube with holes in towbar
- Secure the manual tube to towbar using (2) Self-Tapping Screws
- Reattach the manual tube cover onto the manual tube

Tools Needed

- 11mm Socket Wrench

Fasteners Needed from Parts Bag:

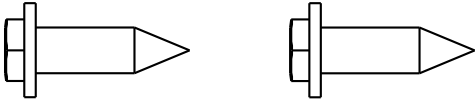

Manual Tube to Tow Bar Screw
Qty: 2

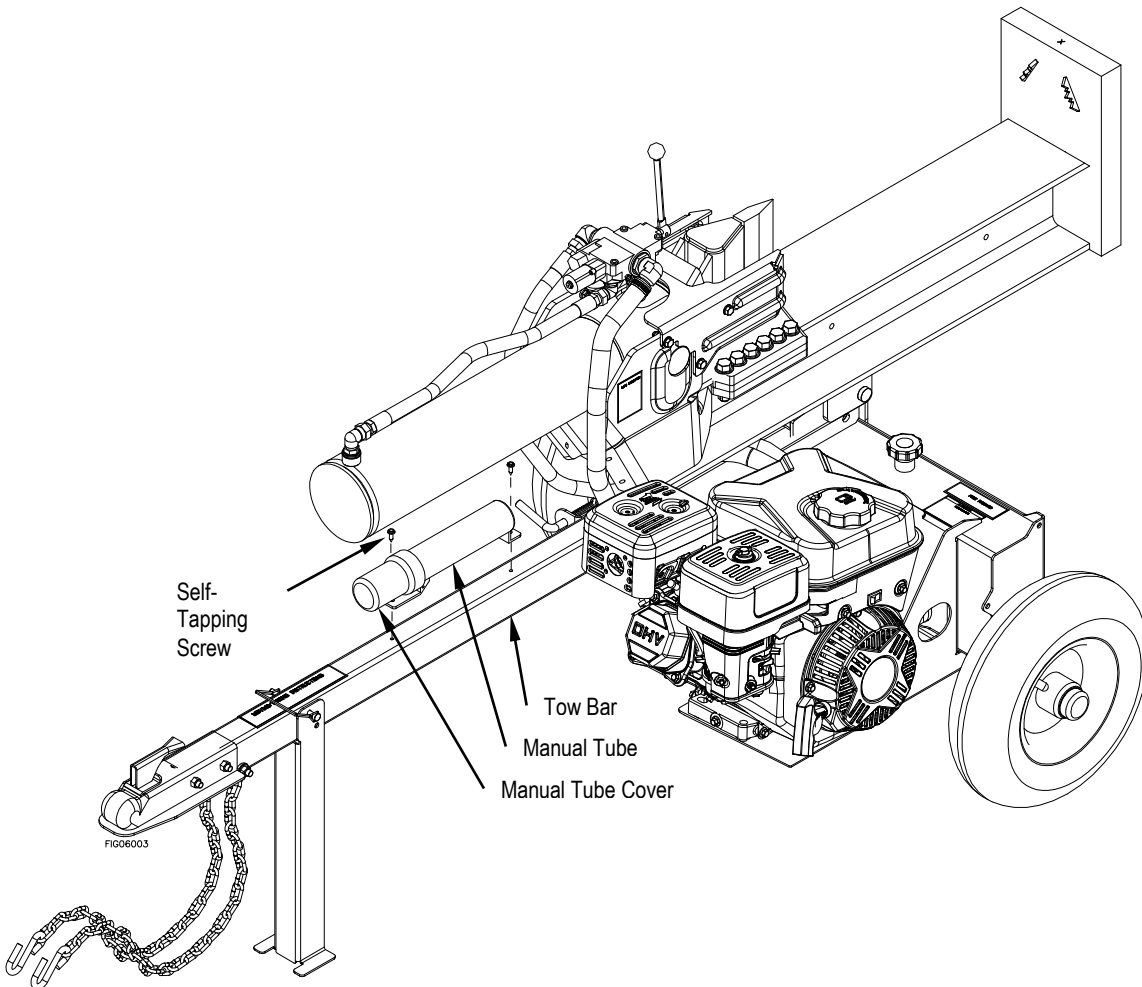

Assembly Instructions

Step 24 – Log Cradles

- Install (2) Log Cradle Bolts and (2) Log Cradle Locknuts into the bottom holes of the beam.
- Using the slots in the bottom of each log cradle arm rest the log cradle arms on the installed bolts and nuts.
- Install the remaining (2) Log Cradle Bolts and (2) Log Cradle Locknuts into the top holes of the beam and log cradle arms.
- Torque to 21 ft.-lb.

Tools Needed

- 13mm Wrench

Fasteners Needed from Parts Bag:

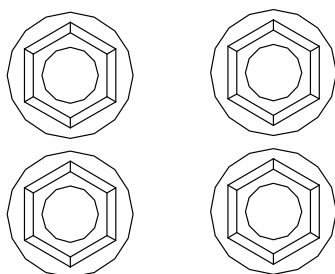

Log Cradles to Beam Nut
Qty: 4

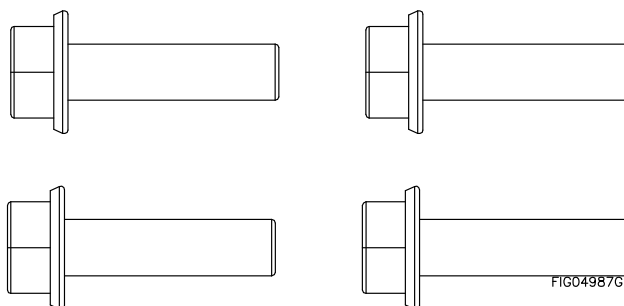

Log Cradles to Beam Bolt
Qty: 4

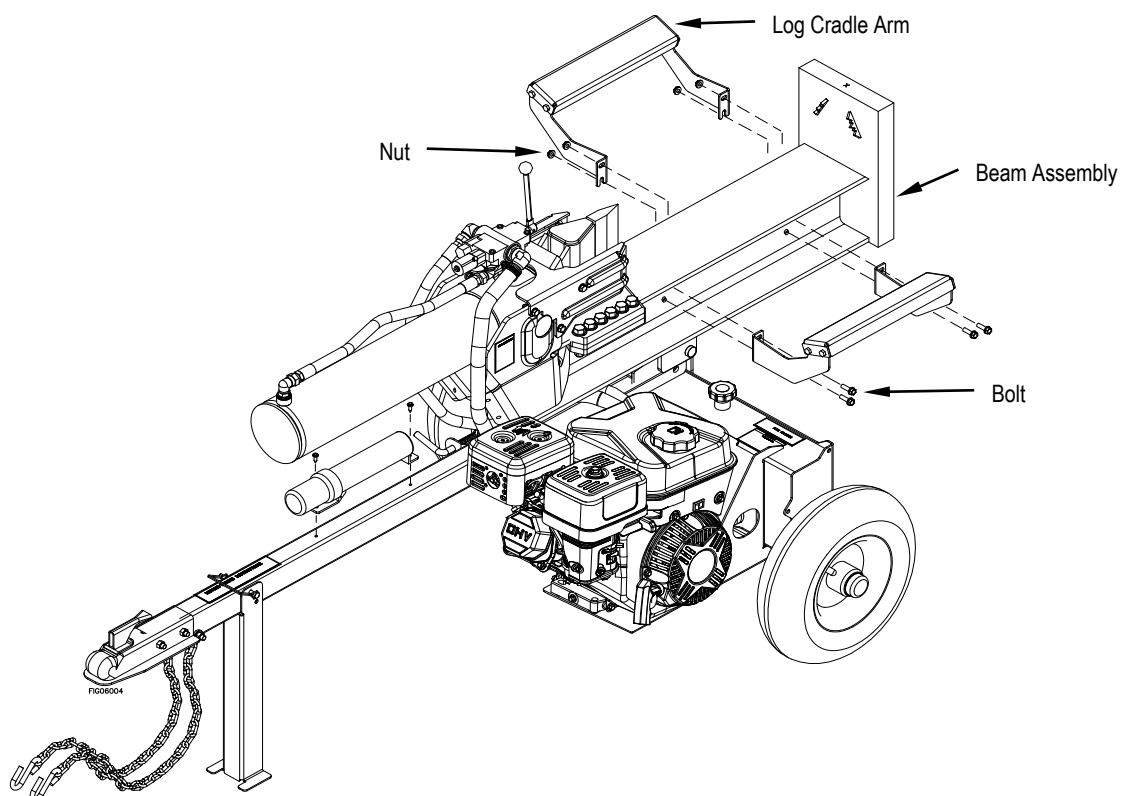

798736 Engine Exploded View



798736 Engine Parts List

Ref #	Part #	Description	Qty
1	N/A	CRANKCASE	1
2	Kit #13	BALL BEARING	2
3		OIL SEAL	2
4	Kit #10	SEAL, GOVERNOR ARM SHAFT	1
5		SHAFT, GOVERNOR ARM	1
6		WASHER, GOVERNOR ARM SHAFT	1
7		PIN, LOCK	1
8	Kit #2	BOLT, DRAIN PLUG	2
9		WASHER, DRAIN PLUG	2
10	Kit #7	SWITCH ASSEMBLY, OIL LEVEL	1
11		BOLT M6X16	2
12	Kit #13	DOWEL PIN, CASECOVER	2
13	N/A	PISTON	1
14	N/A	SCRAPER RING SET, PISTON	1
15	N/A	ROD ASSEMBLY, CONNECTING	1
16	N/A	PIN, PISTON	1
17	N/A	CLIP, PISTON	2
18	Kit #13	COVER ASSEMBLY, CRANKCASE	1
19	796860	OIL PLUG	1
20	Kit #13	BALL BEARING	1
21	N/A	GOVERNOR ASSEMBLY	1
22	N/A	CYLINDER HEAD	1
23	N/A	VALVE, INTAKE	1
24	N/A	VALVE EXHAUST	1
25	N/A	RETURNER, INTAKE VALVE	2
26	N/A	OIL SEAL, VALVE	2
27	N/A	SPRING, VALVE	2
28	N/A	ADJUSTER ROCKER ARM	2
29	N/A	SEAT, VALVE SPRING, EXHAUST	2
30	N/A	PLATE, PUSH ROD GUIDE	1
31	N/A	ROCKER ASSY	2
32	N/A	ROTATOR	2
33	Kit #12	BOLT, STUD	2
34	Kit #11	BOLT, STUD	2
35	Kit #12	CARBURETOR ASSEMBLY	1
36	Kit #1	FUEL LINE	1
37		CLIP, FUEL LINE Φ 7.5	2
38	Kit #10	GOVERNOR ARM	1
39	Kit #8	FLAMEOUT WIRE	1
40		SWITCH ASSEMBLY	1
41	Kit #11	MUFFLER COMP	1
42		GASKET, EXHAUST PIPE	1
43		EXHAUST PIPE	1
44		NUT M8	2
45	N/A	CRANKSHAFT ASSEMBLY	1
46	N/A	LIFTER, VALVE	2
47	Kit #13	PACKING, CASECOVER	1
48	N/A	BALANCING SHAFT	1
49	N/A	CAMSHAFT ASSEMBLY	1
50	Kit #4, Kit #13	BOLT M8X35	9
51	N/A	PIN, DOWEL	2
52	N/A	GASKET, CYLINDER HEAD	1
53	N/A	BOLT M10X80	4

Ref #	Part #	Description	Qty
54	795592	SPARK PLUG	1
55	N/A	ROD, PUSH	2
56	N/A	SHROUD	1
57	Kit #7, Kit #15	BOLT M6X12	9
58	Kit #6	COVER COMP, CYLINDER HEAD	1
59		PACKING, HEADCOVER	1
60		LOCK BOLT	1
61	Kit #4	SHROUD ASSY, UPPER	1
62	Kit #3	CARBON CANISTER ASSEMBLY	1
63	N/A	FLYWHEEL ASSEMBLY	1
64	Kit #5	FAN, RECOIL STARTER	1
65		PULLEY, STARTER	1
66		NUT	1
67	Kit #9	IGNITION COIL ASSY	1
68	Kit #9	BOLT M6X25	2
69	Kit #12	PACKING, INTAKE	1
70		INSULATOR, CARBURETOR	1
71		PACKING, CARBURETOR	1
72	Kit #12, Kit #14	SPACER, CARBURETOR	1
73	Kit #10	ROD, GOVERNOR	1
74		SPRING, THROTTLE RETURN	1
75	Kit #15	RECOIL STARTER ASSEMBLY	1
76	Kit #14	AIR CLEANER ASSEMBLY	1
76a	Kit #14 or 798772	AIR FILTER	1
77	Kit #14	TUBE, BREATHER	1
78	Kit #10	SPRING, GOVERNOR	1
79	Kit #7	AMPLIFIER	1
80	Kit #11	PACKING, EXHAUST	1
81		SPRING WASHER	2
82	796859	DIPSTICK	1
83	Kit #16	FUEL TANK ASSEMBLY	1
84		BOLT M8X25	2
85		NUT M8	2
86	N/A	CLIP	1
87	Kit #3	CONNECTING PIPE	1
88	N/A	CLIP	1
89	N/A	CLIP, WIRE HARNESS	1
90	Kit #16	BUMPER, BREATHER PIPE	1
91		MANUAL CHOKE ASSEMBLY	1
92		BRACKET	1
93		PACKING WASHER	1
94	N/A	LOCKING FLAPS	4
95	Kit #3, Kit #16	CLIP, FUEL LINE Φ 9.5	2
96		CLIP, FUEL LINE Φ 10	2
97	Kit #16 or 798771	FUEL TANK CAP	1
98	Kit #4	SPEED REGULATING HANDLE	1
99	N/A	BOLT M6X28	2
100	N/A	BOLT M6X8	1
101	Kit #8	PLATE, AIR CLEANER	1
102	Kit #16	CONNECTING PIPE	1
103	Kit #14	NUT M6	2
104	Kit #11	NUT M8	3

798736 Engine Kits

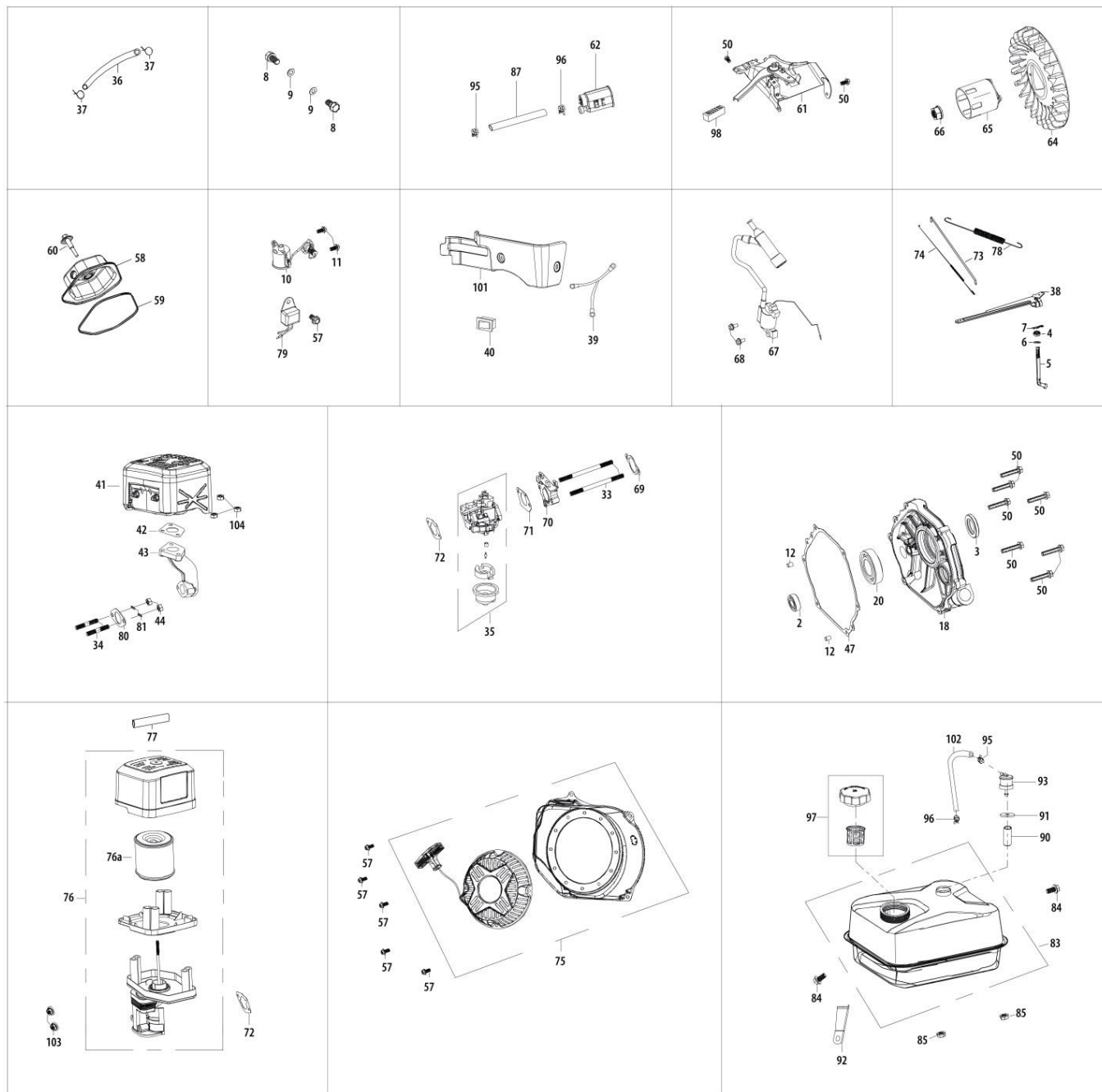

Kit Ref #	Kit Part #	Description	Qty
1	798762	Fuel Line Kit	1
2	795629	Drain Bolt Kit	1
3	798161	Carbon Canister Kit	1
4	798763	Throttle Kit	1
5	795636	Recoil Starter Fan Kit	1
6	795626	Valve Cover Kit	1
7	795634	Oil Level Kit	1
8	798768	On/Off Switch Kit	1

Kit Ref #	Kit Part #	Description	Qty
9	795635	Ignition Coil Kit	1
10	798760	Governor and Spring Kit	1
11	798770	Muffler Kit	1
12	798766	Carburetor Kit	1
13	798769	Crankcase Cover Kit	1
14	798765	Air Cleaner Kit	1
15	798764	Recoil Kit	1
16	798767	Tank Kit	1

Engine

⚠ WARNING

BEFORE operating the engine, be sure to read this section of the manual, otherwise injury to personnel or damage to equipment may occur.

Engine starting components

1. Fuel Valve
When the fuel valve is in the ON position, fuel is allowed to flow from the fuel tank to the carburetor. Be sure to return the fuel valve to the OFF position after stopping the engine.
2. Choke Lever
The choke is used to provide an enriched fuel mixture when starting a cold engine. It can be opened and closed by operating the choke lever manually. Move choke lever to the left toward CLOSED to enrich the mixture for cold starting.
3. Engine Switch
Turn the switch ON, (and pull recoil) to run the engine and to stop the engine turn the switch OFF.
4. Recoil
To start the engine, pull the starter rope lightly until resistance is felt, then pull briskly.
5. Throttle Lever
The throttle lever controls the engine speed. Output is controlled by adjusting the throttle lever.

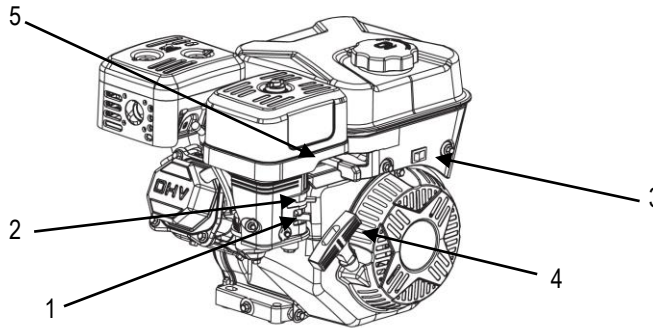

Displacement	420
Starting Type	Recoil/Electric Start
Ignition Type	Transistorized Magneto Ignition
Lubricating Type	Splash
Model	420cc
Spark Plug Gap	0.7-0.8mm (0.028-0.03in)
Spark Plug Torque	20-30N.m
Intake Valve Clearance	0.08-0.12mm (0.003-0.005in)
Exhaust Valve Clearance	0.13-0.17mm (0.005-0.007in)

⚠ WARNING:

Improper maintenance or failure to correct a problem before operation can cause a malfunction in which you can be seriously hurt or killed. ALWAYS follow the inspection and maintenance recommendations and schedules in this manual.

Engine Cont'd

Maintenance schedule	REGULAR SERVICE PERIOD	Before each use	First month or 20 Hrs.	Every 3 months or 50 Hrs.	Every 6 months or 100 Hrs.	Every year or 300 Hrs.	
	Engine oil	Check level	○				
		Change		○		○	
	Air filter	Check	○				
		Clean			○(1)	○(1)	
		Replace					○
	Fuel Valve Sediment Cup	Clean				○	
	Spark plug	Check-adjust				○	
		Replace					○
	Spark arrester	Clean				○	
	Idle speed	Check-adjust					○(2)
	Valve clearance	Check-adjust					○(2)
	Cylinder head	Clean	After every 500Hrs. (2)				
	Fuel tank and filter	Clean	Every 2 years (Replace if necessary) (2)				
Fuel tube	Check	Every 2 years (Replace if necessary) (2)					
<p>(1) Service more frequently when used in dusty areas.</p> <p>(2) These items should be serviced by an authorized generator service center, unless the owner has the proper tools and is mechanically proficient.</p>							
Engine oil recommendations	<p>⚠ CAUTION: Engine damage The log splitter has been shipped WITHOUT oil. Any attempt to start log splitter without oil may result in engine damage and failure.</p> <ul style="list-style-type: none"> • Engine oil is a key factor in deciding the engine's performance. DO NOT use engine oil with additives or 2-stroke gasoline oil, as they lubricate properly, which may shorten the engine's service life. • Check the engine oil level with the generator stopped on a level ground. • Due to viscosity variances with regions and temperatures select the correct type of oil using the chart below. <p>Engine oil recommended: SAE10W-30</p> <p>Capacity: 1.16 US quarts (1.1L)</p>						
	<p>The chart shows the following recommendations:</p> <ul style="list-style-type: none"> 5W-30: -20°F to 0°F (-30°C to -10°C) 10W-30: 0°F to 80°F (-10°C to 30°C) 30: 60°F to 100°F (15°C to 40°C) 						

Engine Cont'd

Oil draining and checking oil level

⚠️ WARNING: Burn hazard

Never open oil port while engine is running. Hot oil can spray over face and body.

1. Operate the log splitter for 3 to 5 minutes to thin oil for easier draining.
2. Ensure that the engine is stopped and on a level surface.
3. Remove the drain bolt and washer; drain the oil into an approved container.

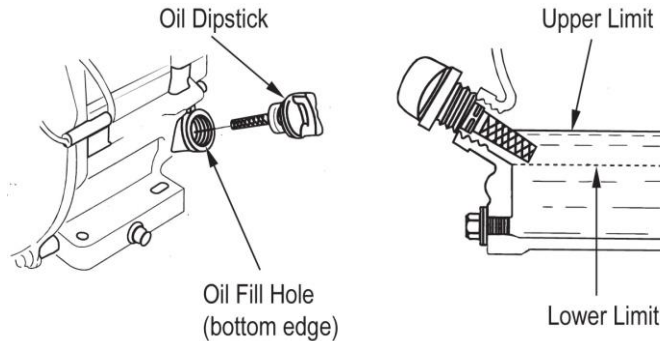

4. Reinstall washer and drain bolt.
5. Remove the dipstick and clean it.
6. Fill crankcase with oil to the bottom lip of the oil filler neck, approximately 1.16 US quarts (1.1L).
7. Reinsert the dipstick into the oil filler without threading in, and check oil level. If the oil level is too low, add recommended engine oil to the oil filler neck.
8. Reinstall the dipstick.

Spark plug removal, cleaning and replacement

Proper spark plug clearance ensures the engine's normal running.

- a) Remove the spark plug cap.
- b) Remove the spark plug using the supplied spark plug wrench.

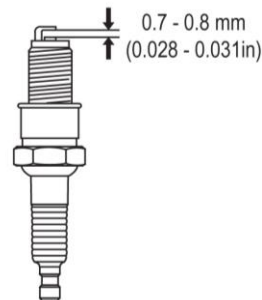
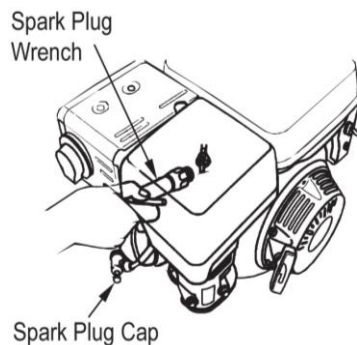

⚠️ WARNING

Be careful not to touch the muffler during or just after the engine has been running.

- c) Clean the spark plug with a steel brush. If the insulator is damaged, replace the spark plug.
- d) Measure the spark plug clearance with a feeler. The clearance should be 0.7-0.8mm. If adjustment is necessary, bend the side electrode carefully.
- e) Check if the spark plug gasket is in good conditions, or replace with a new one. Screw on the spark plug to the bottom first by hand and then tighten it up by a spark plug wrench. If a new spark plug is used, twist 1/2 more turns after impacting the gasket; if reinstall the original one, just twist 1/8-1/4 more turns.

Engine Cont'd

Clean air filter

⚠ WARNING

Never run the log splitter without the air filter. Rapid engine wear will result.

1. Remove the air cleaner outside cover (A). Be careful to prevent dirt and debris from falling into the air cleaner assembly.
2. Separate the Air Filter (A) from the Air Filter Housing (B).
3. Inspect the air filter. Clean dirty air filter with warm water and mild soap. Allow air filter to dry thoroughly before re-installation.
4. Install the air filter assembly onto the carburetor and secure with screws.

Note: Do not use pressurized air or solvents to clean the filter. Pressurized air can damage the filter and solvents will dissolve the filter.

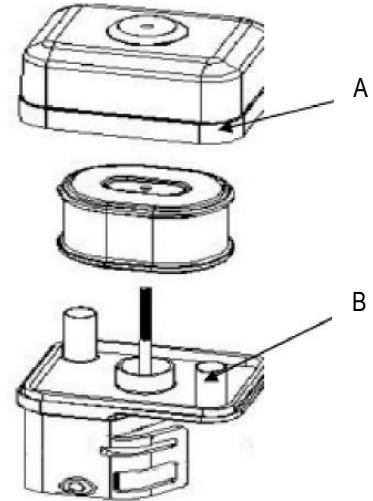

Clean fuel valve sediment cup

The sediment cup prevents dirt or water which may be in the fuel tank from entering the carburetor. If the engine has not been run for a long time, the sediment cup should be cleaned.

1. Close the fuel valve and remove the sediment cup.
2. Remove the O-ring and filter from the sediment cup.
3. Clean the sediment cup, O-ring, and filter in nonflammable or high flash point solvent.
4. Reinstall the filter, O-ring, and sediment cup.
5. Open the fuel valve and inspect for any leakage.

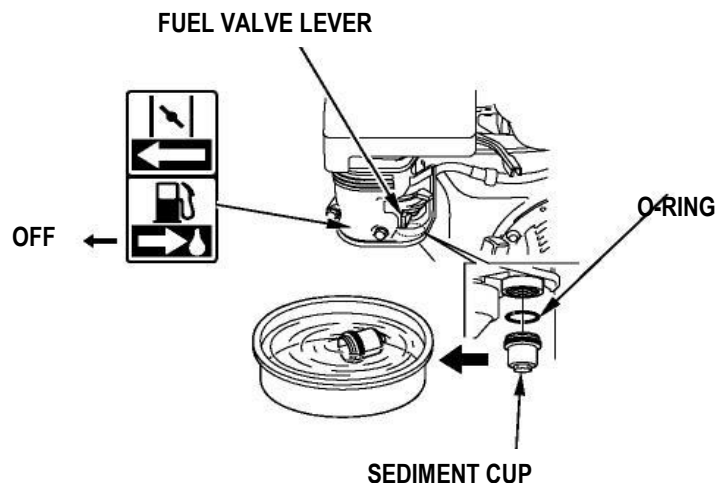

Engine Cont'd

Prepare engine for long term storage if needed	<p>If you will not be able to exercise the log splitter regularly, you must prepare the engine for long term storage to prevent gum deposits from forming and causing malfunction of the engine. Prepare engine for long term storage by:</p> <p style="padding-left: 20px;">Removing all gasoline from the tank and carburetor.</p> <p style="padding-left: 40px;"><u>Draining steps:</u></p> <ol style="list-style-type: none"> 1. Position a UL-listed fuel container below the carburetor drain bolt. 2. Turn fuel valve to the OFF position. 3. Remove the drain bolt and gasket. 4. Turn fuel valve to the ON position and drain fuel from carburetor and tank. 5. Reinstall and tighten the drain bolt and gasket. <p style="text-align: center; font-size: 1.5em; font-weight: bold; margin: 20px 0;"><u>OR</u></p> <p style="padding-left: 20px;">Adding fuel stabilizer to the gasoline (following manufacturer's instructions).</p> <p style="padding-left: 40px;"><u>Fuel stabilizer steps:</u></p> <ol style="list-style-type: none"> 1. Ensure gasoline tank is full. 2. Add fuel stabilizer to fuel tank. 3. Run engine at least 10 minutes after adding stabilizer to allow it to enter the fuel system. 4. Shut off engine. 5. Disconnect spark plug wire and remove spark plug using provided spark plug wrench. 6. Add one teaspoon oil through spark plug hole. 7. Place rag over spark plug hole and turn starter (or pull the recoil) a few times to lubricate the combustion chamber. 8. Replace spark plug, but do NOT reconnect the spark plug wire. 										
Removal from storage	<p>⚠ WARNING Gasoline is highly flammable and explosive, and you can be burned or seriously injured when handling fuel.</p> <table border="1" style="width: 100%; border-collapse: collapse; margin: 10px 0;"> <thead> <tr> <th style="width: 40%; text-align: center;">Storage time</th> <th style="text-align: center;">Service item</th> </tr> </thead> <tbody> <tr> <td style="text-align: center;">Within one month</td> <td>Use</td> </tr> <tr> <td style="text-align: center;">One-two months</td> <td>Drain original fuel and refuel.</td> </tr> <tr> <td style="text-align: center;">Two months - one year</td> <td>Drain original fuel and refuel; Empty and clean the fuel valve sediment cup.</td> </tr> <tr> <td style="text-align: center;">One year or longer</td> <td>Drain original fuel and refuel; Empty and clean the fuel valve sediment cup; Empty and clean the carburetor bowl.</td> </tr> </tbody> </table> <p>Draining fuel:</p> <ol style="list-style-type: none"> 1. Turn the fuel valve to the OFF position. 2. Place a UL-listed container below the carburetor; use a funnel to avoid spillage. 3. Remove the carburetor drain bolt and gasket. 4. Turn the fuel valve to the ON position to drain fuel into a UL-listed container. 5. Reinstall and tighten the drain bolt and gasket. 	Storage time	Service item	Within one month	Use	One-two months	Drain original fuel and refuel.	Two months - one year	Drain original fuel and refuel; Empty and clean the fuel valve sediment cup.	One year or longer	Drain original fuel and refuel; Empty and clean the fuel valve sediment cup; Empty and clean the carburetor bowl.
Storage time	Service item										
Within one month	Use										
One-two months	Drain original fuel and refuel.										
Two months - one year	Drain original fuel and refuel; Empty and clean the fuel valve sediment cup.										
One year or longer	Drain original fuel and refuel; Empty and clean the fuel valve sediment cup; Empty and clean the carburetor bowl.										

Engine Cont'd

High Altitude Operation

CAUTION: Operating at an altitude of greater than 2000 feet (610 meters) may affect your engines performance, fuel consumption, and emissions. To remain emissions compliant and improve engine performance at higher altitudes, a high-altitude kit is required. A high altitude kit includes a carburetor jet resized to help correct air / fuel mixture at altitude. To order a high altitude kit or if you have additional questions, go to www.northerntool.com or contact us at 1-866-443-2576 – Powerhorse. Please note, engines with the high-altitude kit installed operated at lower altitudes could cause severe engine damage and affect emissions compliance. When modified, a tag or decal should be added to the product stating that a high-altitude kit was installed and to remind you to re-service the carburetor (re-jet) when operating in lower altitude environments.

Limited Warranty

Dear Valued Customer:

The Powerhorse Product you just purchased is built with the finest material and craftsmanship. Use this product properly and enjoy the benefits from its high performance. By purchasing a Powerhorse product, you show a desire for quality and durability. Like all mechanical equipment this unit requires a due amount of care. Treat this unit like the high quality piece of machinery it is. Neglect and improper handling may impair its performance. Please thoroughly read the instructions and understand the operation before using your product. Always contact Powerhorse Product Support at 1-866-443-2576 prior to having any service or warranty work performed, as some services performed by parties other than Powerhorse approved service centers may void this warranty. This warranty is in lieu of any other warranty expressed or implied and Powerhorse assumes no other responsibility or liability outside that expressed within this warranty.

Limited Warranty

Powerhorse shall warranty any piece of equipment manufactured, or parts of equipment manufactured, to be free from defects in material or workmanship for a period of:

Powerhorse Warranty		
Item #	Consumer Warranty Period	Commercial Warranty Period
1169	3 years from date of purchase by user	N/A

Powerhorse Engine Warranty		
Item #	Consumer Warranty Period	Commercial Warranty Period
1169	2 years from date of purchase by user	N/A

“Consumer use” means personal residential household use by a consumer. “Commercial use” means all other uses, including use for commercial, income producing or rental purposes or when purchased by a business.

This warranty applies to the original purchaser of the equipment (verification of purchase, in the form of a receipt, is the responsibility of the buyer), is non-transferable, and covers parts and labor. Parts will be replaced or repaired at no charge, except when the equipment has failed due to lack of proper maintenance. If a part is no longer available, the part may be replaced with a similar part of equal function. Any misuse, abuse, alteration or improper installation or operations will void warranty. Determining whether a part is to be replaced or repaired is the sole decision of Powerhorse. Powerhorse will not provide for replacement of complete products due to defective parts. Any costs incurred due to replacement or repair of items outside of a Powerhorse approved facility is the responsibility of the buyer and not covered under warranty. Transportation costs to and from service center is the responsibility of the customer.

In addition to the normal warranty, Powerhorse shall warrant any normal wear item from defects in material or workmanship for a period of 90 days from the date of purchase by user. Normal wear items include, but are not limited to, nozzles, quick connect fittings, valves, seals, hoses, springs, O-rings, unloader valves and filter elements.

This warranty specifically excludes the following; failure of parts due to damage caused by accident, fire, flood, windstorm, acts of God, applications not approved by Powerhorse in writing, corrosion caused by chemicals, use of replacement parts which do not conform to manufacturer's specifications, damage related to rodent and/or insect infestation and damage caused by vandalism. Additional exclusions: loss of running time, inconvenience, loss of income, or loss of use, including any implied warranty of merchantability of fitness for a specific use. Also, Outdoor Power Equipment needs periodic parts and service to perform well, and this warranty does not cover instances when normal use has exhausted the life of a component or the engine.

This warranty does not cover any personal injury or damage to surrounding property caused by failure of any part. Repair or replacement of parts does not extend the warranty period.

The engine warranty is covered under the same terms and conditions as outlined above. Normal engine maintenance such as spark plugs, air filters, adjustments, fuel system cleaning and obstruction due to build up is not covered by this Powerhorse warranty.

Tel: 1-866-443-2576

Website: www.northerntool.com

Please fill in the following information and have it on hand when you call in on a warranty claim.

Customer Number: _____

Date of Purchase: _____

Powerhorse Serial Number: _____

Item Number: _____

This page left intentionally blank



POWERHORSE[®]

Distributed by
Northern Tool & Equipment
Company, Inc.
Burnsville, MN 55306
www.northerntool.com
Made in China