

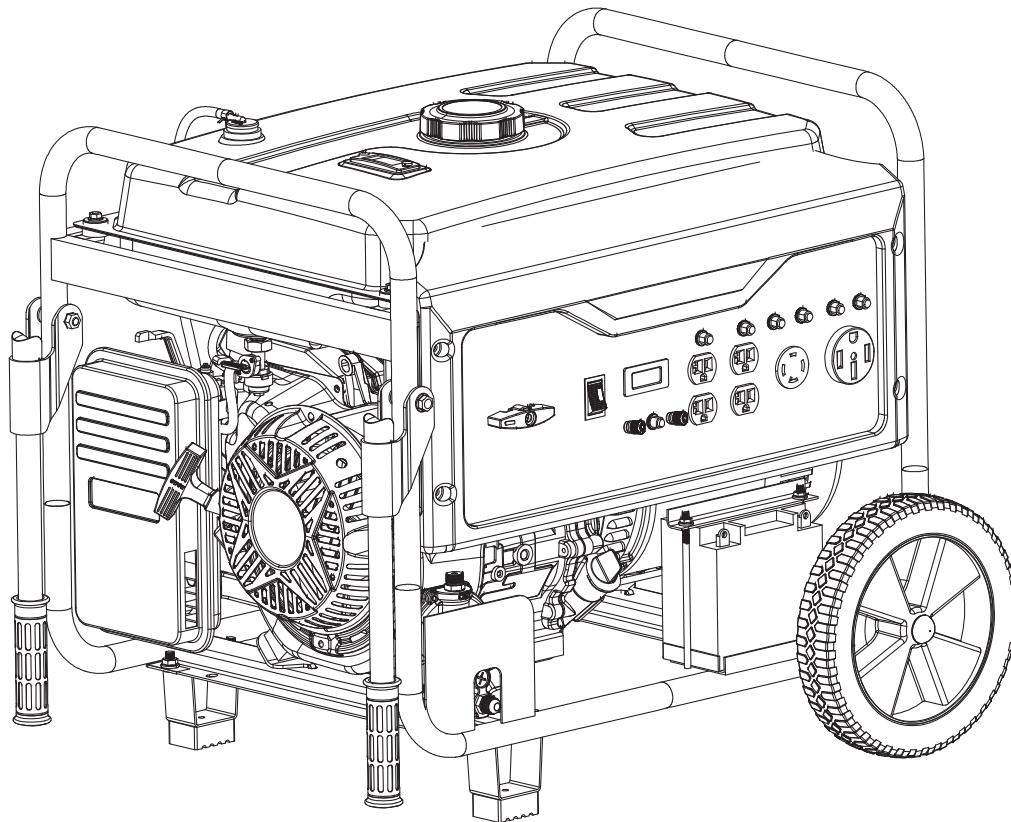

Model: PG12000B

Generator OPERATOR'S MANUAL



Warning: The Engine Exhaust from this product contains chemicals known to the State of California to cause cancer, birth defects or other reproductive harm.

TABLE OF CONTENTS

Introduction	3
Product Specifications	3
Parts Ordering / Customer Service	3
Safety Rules	4
Safety Symbols	4
Safety Instructions	4
Features	7
Assembly	9
Unpacking.....	9
Packing List	9
Remove Shipping Bracket	10
Attaching Wheels	10
Installing support leg	10
Installing the handles	11
Attaching battery cable	11
Adding Oil/Checking engine oil	12
Adding Fuel.	13
Connecting Generator to an Electrical System.	13
Operation	14
Grounding the Generator	14
How to Start Engine.	14
How to Stop Engine.	15
Receptacles and Extension Cords.....	15
Don't Overload Generator.....	16
Wattage Reference Guide.	17
Cold Weather Operation.	18
Maintenance	19
Maintenance Schedule	19
Changing Oil	20
Engine Maintenance	21
Maintaining Fuel Valve.	22
How to Store	23
Troubleshooting	24
Diagrams	25
Warranty	26

INTRODUCTION

Thank you for purchasing this superior quality portable generator from Pulsar Products Inc. When operating and maintaining this product as instructed in this manual, your generator will give you many years of reliable service.

Product Specifications:

This generator is an engine-driven, revolving field, alternating current (AC) portable generator. It is designed to supply electrical power to operate tools, appliances, camping equipment, lighting, or serve as a back up power source during power outages.

AC Output		GAS	LPG
	Rated Wattage	9500W (9.5kW)	8550W (8.55kW)
	Rated Voltage	120V/240V	120V/240V
	Rated Frequency	60Hz	60Hz
	Rated Ampere	79A / 39.5A	71.25A / 35.6A
	Rated Output	9.5kVA	8.55kVA
	Maximum Output	12kVA	10.8kVA
Engine	457cc OHV, 4 Stroke, Air Cooled		
Engine Oil	10W30 - 38oz (1.1L)		
Fuel Tank	8.0 Gal (31L) Unleaded Gasoline		

The emissions control system for this generator is compliant with all standards set by the U.S. Agency.

How to contact us:

To order parts, receive warranty assistance, or other services inquiries, you can contact us by internet at www.pulsar-products.com or write to us at:

PULSAR PRODUCTS INC
5721 E. SANTA ANA AVE.
ONTARIO. 91761
1-866-591-8921

Record the following information below for service or warranty assistance.

Date of Purchase:	
Model Number:	
Item Number:	
Serial Number:	



SAVE THIS MANUAL FOR FUTURE REFERENCE

This manual contains important information regarding safety, operation, and maintenance.

SAFETY RULES

Safety Symbols



Indicates a potentially hazardous situation which could result in serious injury or death if not avoided.



Indicates a potentially hazardous situation which could result in damage to equipment or property.



Toxic Fumes



Risk of fire



Risk of explosion



Risk of electric shock



Hot surface



Lifting hazard

Safety Instructions

The manufacturer cannot anticipate every possible hazardous circumstance that the user may encounter. Therefore, the warnings in this manual, on tags, and on affixed decals are not all-inclusive. To avoid accidents, the user must understand and follow all manual instructions and use common sense.



WARNING!

Read and understand this manual in its entirety before operating this generator. Improper use of this generator could result in serious injury or death.



WARNING!



Do not operate indoors or in a confined space preventing dangerous carbon monoxide gas from dissipating.

- Using a generator indoors **WILL KILL YOU IN MINUTES!**
- Carbon monoxide gas is a poisonous, odorless gas that can cause headache, confusion, fatigue, nausea, fainting, sickness, seizures, or death. If you start to experience any of these symptoms, **IMMEDIATELY** get fresh air and seek medical attention.
- Never use indoors, in a covered area, or in a confined space, even if doors and windows are open.
- Install a battery operated carbon monoxide alarm near bedrooms.
- Keep exhaust from this unit from entering a confined area through windows, doors, vents, or other openings.
- When working in areas where vapors could be inhaled, use a respirator mask according to all of its instructions.



WARNING!

Engine exhaust contains chemicals that lead to cause cancer and birth defects.

- Always wash hands after handling generator.



WARNING!



To reduce the risk of serious injury, avoid attempting to lift the generator alone.

SAFETY RULES



WARNING!

Never exceed generator's wattage / amperage capacity. This could damage the generator and / or connected electrical devices.

- Check operating voltage and frequency requirements of all electrical devices prior to plugging them into the generator.



WARNING!

Never start or stop engine with electrical devices plugged in to the receptacles. Failure to do so could damage the generator and / or connected electrical devices.

- Always start the engine and let it stabilize before connecting any electronic devices.
- Disconnect all electronic devices before stopping the engine.



WARNING!

Starter and other moving parts can catch on clothing, jewelry, and hair.

- Do not wear loose clothing or gloves.
- Remove jewelry or anything else that could be caught in moving parts.
- Tie back or wear protective head covering to contain long hair.



WARNING!



Keep engine away from flammable objects and other hazardous materials.

- The fuel and its vapors used to power this unit are highly flammable and could explode resulting in serious injury or death.
- Never fill or drain fuel tank indoors.
- Never overfill fuel tank. If fuel spills, move the unit at least 30 feet away from the spill and wipe up any remaining fuel on the unit before starting the engine.
- Never smoke while operating or fueling this unit.
- Never operate or store this unit near an open flame, heat, or any other ignition source.
- Generator should have at least 5 feet of clearance from buildings or other equipment during operation.
- Keep engine free of grass, leaves, or grease which are flammable.
- When adding or draining fuel, unit should be turned off for at least 2 minutes to cool before removing fuel cap. If unit has been running then the fuel cap is under pressure, remove slowly.
- To keep fuel from spilling, secure unit so it cannot tip while operating or transporting.
- When transporting unit, disconnect the spark plug wire and make sure the fuel tank is empty with the fuel shutoff valve turned to the off position.



WARNING!

Pull cord recoils rapidly and pulls arm towards engine faster than you can let go which could result in injury.

- To avoid recoil, pull starter cord slowly until resistance is felt, then pull rapidly.



WARNING!



Avoid contacting hot areas of this unit.

- Use caution around the muffler, cylinder, and other engine parts as they can be extremely hot.
- Allow hot components to cool before touching.

SAFETY RULES

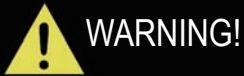

WARNING!



This generator produces a very high voltage which could result in burns or electrocution causing serious injury or death.

- Never handle the generator, electronic devices, or any cord while standing in water, while barefoot, or when hands or feet are wet.
- Always keep the generator dry. Never operate generator in rain or under wet conditions.
- Use a ground fault circuit interrupter (GFCI) in a damp or highly conductive area, such as metal decking or steel work.
- Never plug electronic devices into generator having frayed, worn, or bare wires. Never touch bare wires or make contact with receptacles.
- Never permit a child or unqualified person to operate generator. Keep children a minimum of 10 feet away from the generator at all times.
- If using the generator for back up power, notify the utility company.
- If connecting generator to a building's electrical system for standby power, you must use a qualified electrician to install a transfer switch. Failure to isolate the generator from the power utility could result in serious injury or death to electric utility workers.



WARNING!



Generator must be properly grounded to prevent electrocution.

- Only operate generator on a level surface.
- Always connect the nut and ground terminal on the frame to an appropriate ground source.



WARNING!

Never modify this unit in any way or modify governed speed.

- Increasing governing speed is dangerous which can result in personal injury and / or damaged equipment.
- Decreasing governing speed adds an excessive load and can damage equipment.
- Only when operating at the preset governing speed will this generator will supply the correct rated frequency and voltage.



WARNING!

Only use this unit as intended or serious injury or death could result.

- Do not bypass any safety device. Moving parts are covered with guards. Make sure all protective covers are in place.
- Never transport or make adjustments to this unit while it is running.
- Never insert objects through cooling slots.



WARNING!

Never operate this unit if there are any broken or missing parts and only use Ford Power Equipment replacement parts specifically designed for this unit.

- Improper treatment of generator can damage the unit and shorten it's life.
- Always repair this unit as specified in this manual. If you have any questions contact your dealer or consult a qualified service center.
- Shut generator off if electrical output is missing, unit vibrates excessively or begins to smoke, spark or emit flames.

PROP 65 WARNING: This product contains chemicals known to the state of California to cause cancer and birth defects or other reproductive harm.

FEATURES

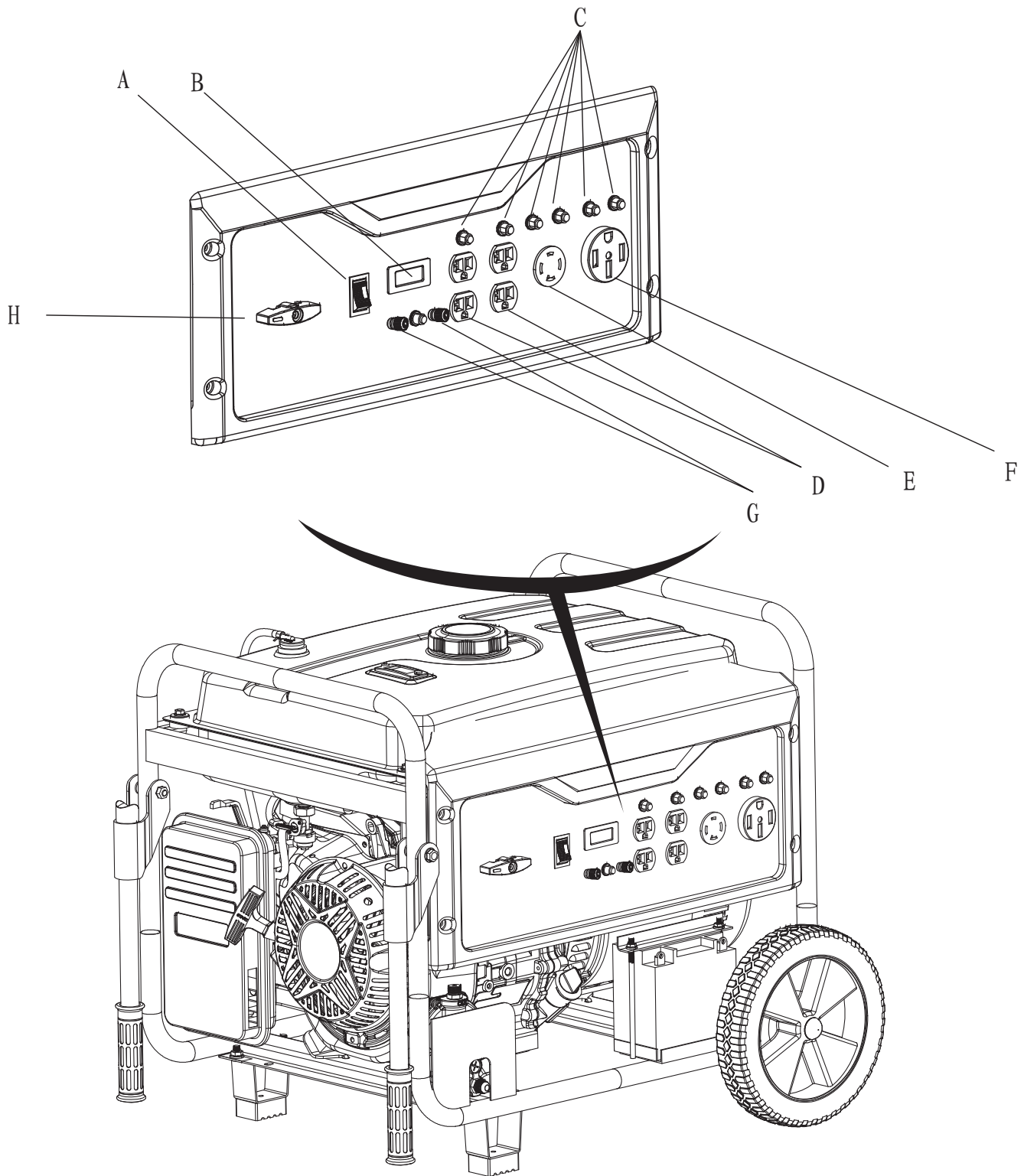

A - START/ON/OFF Switch

B - Hour Meter

C - Circuit Protector

D - Two 120 Volt AC, 20Amp Receptacles

E - 120 / 240 Volt AC, 30 Amp twist lock receptacle (NEMA L14-30)

F - 120 / 240 Volt AC, 50 Amp receptacle (NEMA L14-50R)

G - 12 Volt 8.3 Amp Output (For charging batteries only)

H - Fuel Selector Switch

FEATURES

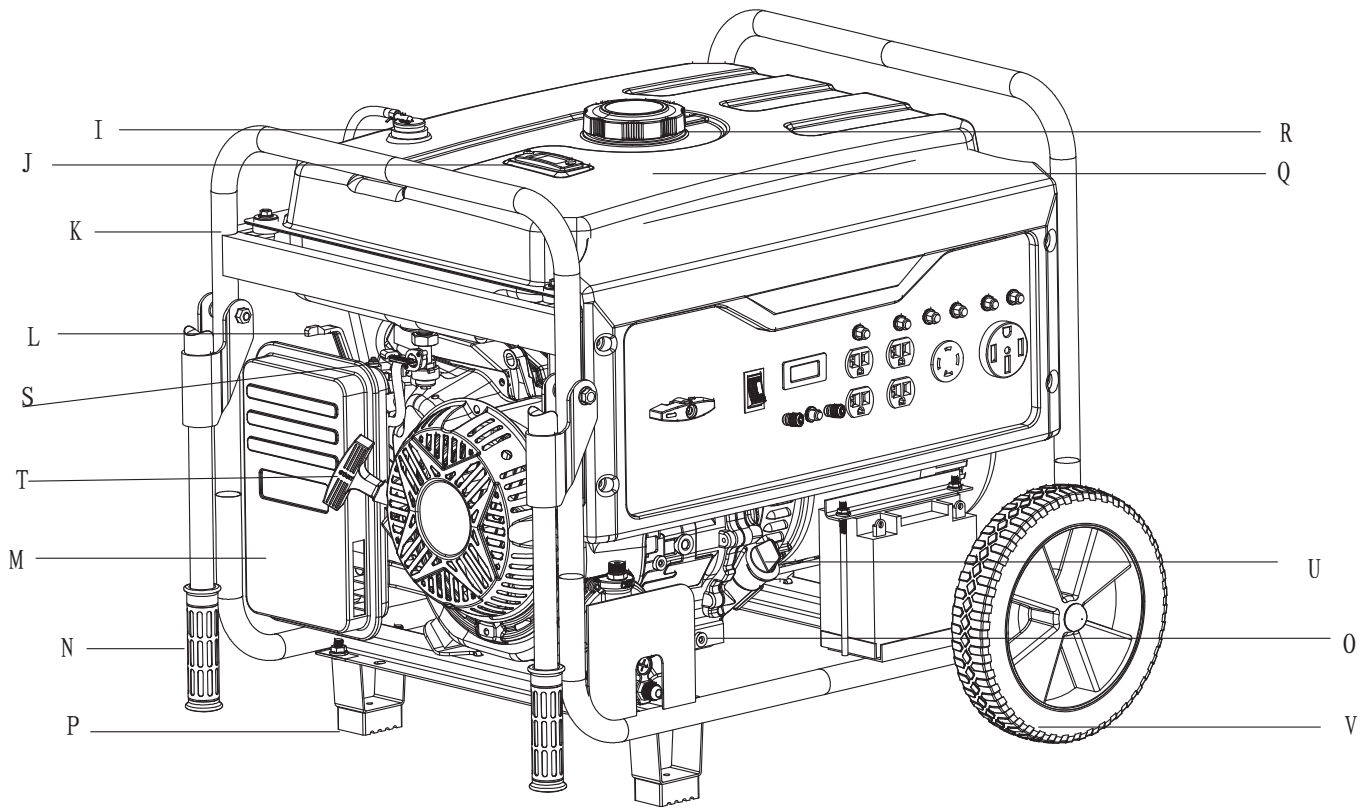

I - Fuel Tank Vapor Vent
J - Fuel Gauge
K - Generator Frame
L - Choke Lever
M - Air Filter
N - Handles & Grip
O - Oil Drain Plug
P - Support Leg (Foot)

Q - Fuel Tank
R - Fuel Fill Cap
S - Fuel Valve (ON/OFF)
T - Recoil Starter Grip
U - Oil Fill (Dipstick)
V - No Flat Foam Filled Tires

ASSEMBLY

Unpacking

1. Place box on a level surface.
2. Remove all items from box except the generator. Make sure all items listed on the packing list are included and not damaged.
3. Cut down the sides of box being careful to avoid hitting the generator.
4. Leave generator on box to install wheel assembly.

Packing List

Check all loose parts to the following list. Contact your dealer if any loose parts are not included.

Description	Qty	
Generator	1	
Operator 's Manual	1	
Products Warranty Card	1	
Toolkit	Spark Plug Wrench	1
	Combination Wrench	2
Funnel	1	
Handles	2	
Bushings (Flanged)	4	
One stage regulator	1	

Description	Qty
Wheel	2
Axle	2
Hair pin	2
Screw	2
Washer	2
Supporting Leg	2
Nuts	2

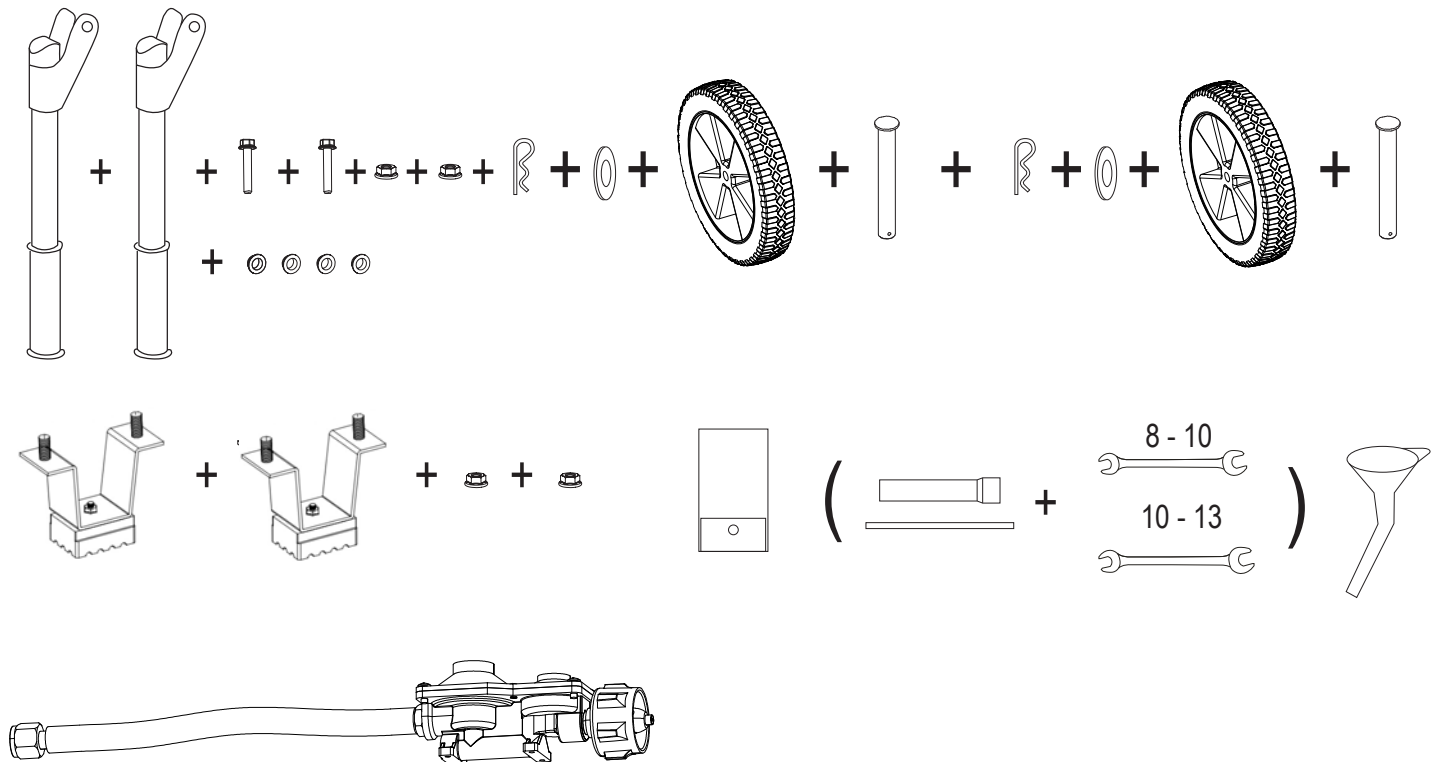

ASSEMBLY

Attaching Wheels (See fig 1)

- Parts needed - 2 wheels, 2 axles, 2 hair pins, and 2 washers.
- Raise or tilt generator so you can slide the wheel axle pin into the wheel, the washer, the wheel mounting hole located on the side of the frame.
- Secure the wheel assembly by reinserting a hair pin through hole at the end of the wheel axle and pressing until it locks into place.
- Repeat process on the other side of the generator to install the second wheel.

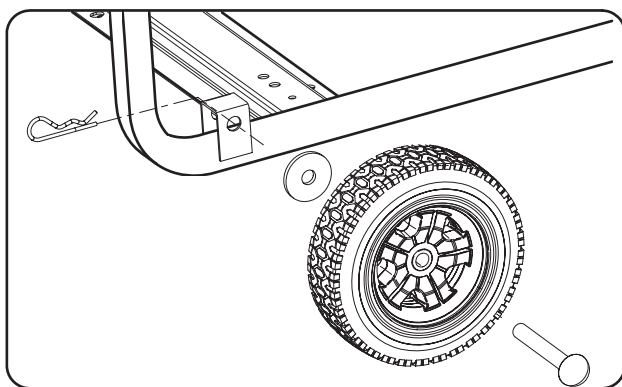

Fig 1

Installing Support Leg (See fig 2)

- Parts needed - Support leg & M8 screw (2) and 2 nuts.
- Raise the front end of the generator high enough to gain access to the bottom of the frame. Securely position props underneath to support.
- Line up holes on the support leg bracket to the holes on the front of the generator frame.
- Attach the support leg using M8 screws (2) and nuts.

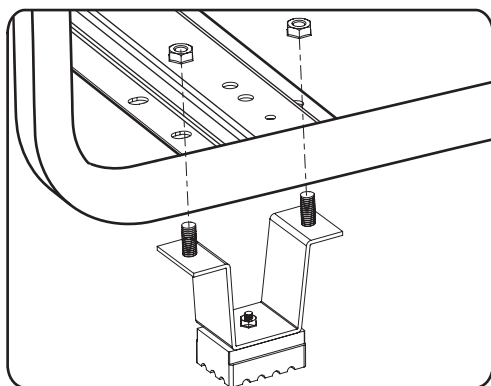

Fig 2

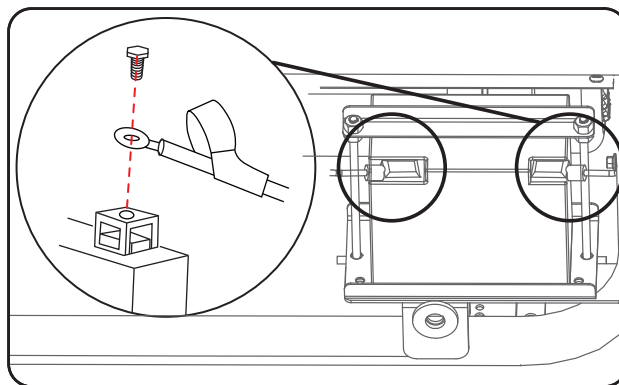

Fig 3

ASSEMBLY

Attaching Battery Cable (See fig 3)

- Parts needed - Black and Red battery cable
- The Red (+) Connector should be attached to the battery first.
- Remove the screw from the battery terminal.
- Place the screw through the eyelet and tighten the screw and make sure the terminal will not touch any part of the frame.
- Install the Red protection boot.
- Repeat these steps for the Black (-) Terminal.



CAUTION!

Be careful not to short across the terminals when installing. Shorting the terminals together can cause sparks, damage to the battery or generator, or even burns or explosions.

Cover the terminals with the rubber covers

When removing the battery for replacement: Remove the nut and bolt first from the negative (Black) post, then from the positive (Red) post, being careful not to short across the terminals. Always abide by the safety warnings provided with the battery. Remove the battery and dispose of it according to your local and state regulations.



WARNING!

Battery posts, terminals, and accessories contain lead and lead compounds known to cause cancer and reproductive harm.

- Always wash hands after touching battery.

Intalling The Handles (See fig 4)

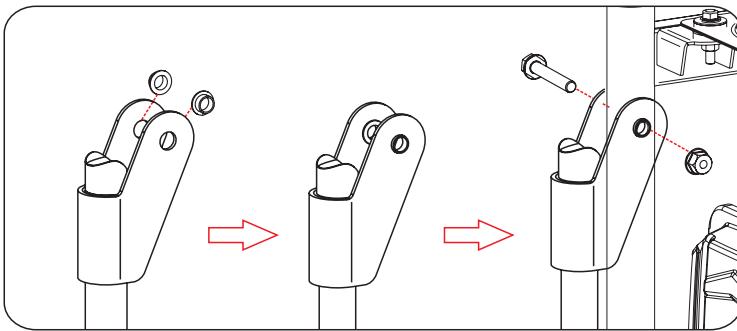

Fig 4

ASSEMBLY

NON-SPILLABLE SEALED BATTERY

This is a ready filled, activated sealed battery. Never remove strip. Refer to owner's manual or instruction sheet for charging procedures.



! DANGER/POISON



SHIELD EYES. EXPLOSIVE GASES CAN CAUSE BLINDNESS OR INJURY



NO
• SPARKS
• FLAMES
• SMOKING



SULFURIC ACID CAN CAUSE BLINDNESS OR SEVERE BURNS



FLUSH EYES IMMEDIATELY WITH WATER

GET MEDICAL HELP FAST

WARNING!

- Wear Eye Protection
- Never Reverse Pole Connections
- Never turn the battery upside down
- DO NOT Smoke near the battery
- If electrolyte contact the skin wash the area immediately with clean water
- If you get electrolyte contact with your eye, rinse immediately with clean water and seek medical attention

NOTICE:

- If the Generator is stored for over six months the battery will need to be removed and charged

PROPOSITION 65 WARNING

- Battery posts, terminals, and related accessories contain lead and lead compounds, chemicals known to the State of California to cause cancer and reproductive harm.
- Wash hands after handling.



Antidotes for battery acid

CONTACT	TREATMENT
External	Flush with water.
Internal	Drink large quantities of milk or water, followed by milk of magnesia, vegetable oil or beaten eggs. Get immediate medical attention.
Eyes	Flush with water. Get immediate medical attention.

Adding / Checking Engine Oil (See fig 5)

- Place generator on a level surface.
- Remove the crankcase dipstick to ensure you do not overfill the engine.
- Insert a funnel into the crankcase dipstick hold and carefully add 4-Cycle engine oil (SAE10W- 30) to empty reservoir until oil reaches the outer edge of the oil fill hole (crankcase dipstick hole).
- Be sure to replace dipstick before attempting to start the engine.
- To check oil, set generator on a level surface, wipe dipstick clean, then reinsert dipstick without rethreading.

ASSEMBLY

Adding Fuel (See fig 6)

- Set generator on a clean and level surface in an area that is well ventilated.
- Remove fuel cap.
- Insert a funnel into the fuel tank and carefully pour gasoline into the tank until fuel level reaches 1 ½ inches below the top of the neck. Be careful not to overfill the tank to provide space for fuel expansion.



CAUTION!

You must add oil before first operating this generator. Always check oil level before each operation.

DO NOT USE E15 OR E85 FUEL IN THIS UNIT. IT IS A VIOLATION OF FEDERAL LAW AND WILL DAMAGE THE UNIT AND VOID YOUR WARRANTY.

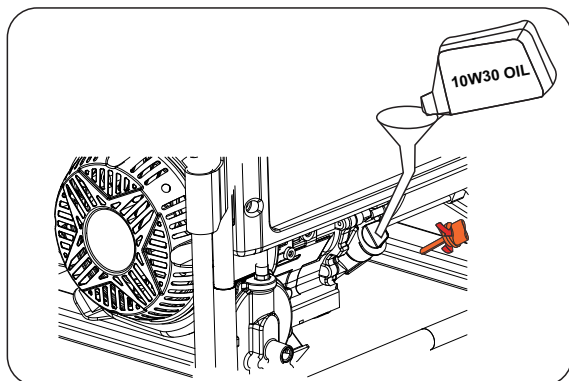

Fig 5

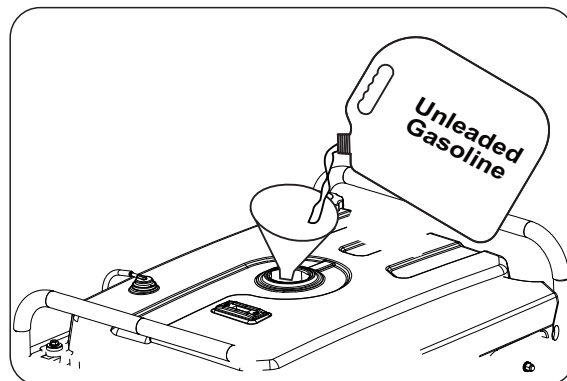

Fig 6

Connecting Generator to an Electrical System

- If connecting generator to a building's electrical system for standby power, you must use a qualified electrician to install a transfer switch. The power from the generator must be isolated from the circuit breaker or alternative power source. The connection must comply with all electrical codes and applicable laws.



WARNING!



This generator produces a very high voltage which could result in burn or electrocution causing serious injury or death.

- Never handle the generator, electronic devices, or any cord while standing in water, while barefoot, or when hands or feet are wet.
- Always keep the generator dry. Never operate generator in rain or under wet conditions.
- Use a ground fault circuit interrupter (GFCI) in a damp or highly conductive area, such as metal decking or steel work.
- Never plug electronic devices into generator having frayed, worn, or bare wires. Never touch bare wires or make contact with receptacles.
- Never permit a child or unqualified person to operate generator. Keep children a minimum of 10 feet away from the generator at all times.
- If using the generator for back up power, notify the utility company.
- If connecting generator to a building's electrical system for standby power, you must use a qualified electrician to install a transfer switch. Failure to isolate the generator from the power utility could result in serious injury or death to electric utility workers.

OPERATION

Grounding the Generator (See fig 7)

The ground terminal located on the back of the generator frame must always be used to connect generator to a driven ground rod. Connect the ground terminal to the driven ground rod with a No 8 AWG (American Wire Gauge) copper wire. The wire connects to the terminal between the lock washer and nut. Tighten the nut securely to ensure proper connection. Grounding the generator protects you from electric shock that results from a build up of static electricity or undetected ground faults.

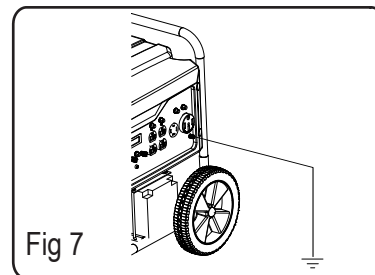

WARNING!



Generator must be properly grounded to prevent electrocution.

- Only operate generator on a level surface.
- Always connect the nut and ground terminal on the frame to an appropriate ground source.

How to Start Engine (See fig 8-14)

- Place generator on a level surface. All electrical loads **MUST** be disconnected from generator.

When using gasoline

- Turn fuel valve to the “ON” position. (See fig 9)
- Turn the fuel selector to “GAS” position (See fig 10)
- Slide the choke lever to the “Choke” position. (See fig 11) **SKIP THIS IF THE ENGINE IS WARM OR HOT.**
- For electric start, Push and hold the engine START/ON/OFF switch in the “START” position. Do not hold the START/ON/OFF switch in the “Start” position for more than 15 seconds. Allow 1 minute between starting attempts. (See fig 12)
- For manual start, turn the engine START/ON/OFF switch to the “ON” position. Pull the recoil handle (starter cord) slowly until resistance is felt, then pull rapidly. (See fig 13)
- Let engine run for several seconds and then gradually, as engine warms up, slide the choke lever towards the “RUN” position until the choke is fully slid to the “RUN” position. (See fig 14)

When using LPG

- Connect the gas pipe to the intake nozzle of regulator ; Open the valve of LPG bottle (See fig 8)
- Turn the fuel selector to “LPG” position (See fig 10)
- Slide the choke lever to the “Choke” position. (See fig 11) **SKIP THIS IF THE ENGINE IS WARM OR HOT.**
- For electric start, Push and hold the engine START/ON/OFF switch in the “START” position. Do not hold the START/ON/OFF switch in the “Start” position for more than 15 seconds. Allow 1 minute between starting attempts. (See fig 12)
- For manual start, turn the engine START/ON/OFF switch to the “ON” position. Pull the recoil handle (starter cord) slowly until resistance is felt, then pull rapidly. (See fig 13)
- Let engine run for several seconds and then gradually, as engine warms up, slide the choke lever towards the “RUN” position until the choke is fully slid to the “RUN” position. (See fig 14)

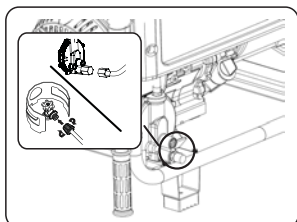

Fig 8

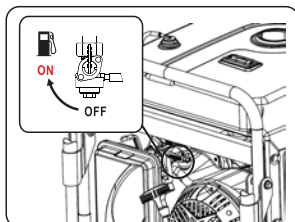

Fig 9

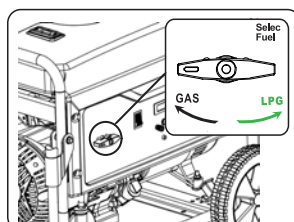

Fig 10

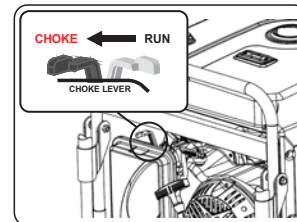

Fig 11

SKIP THIS IF THE ENGINE IS WARM OR HOT.

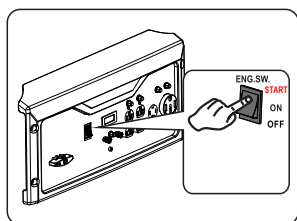

Fig 12 Electric Start

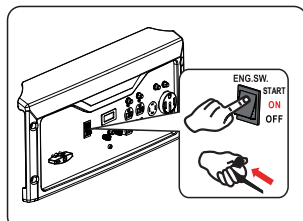

Fig 13 Recoil Start

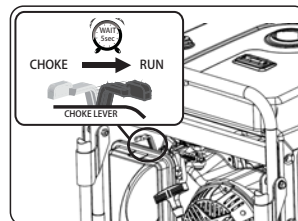

Fig 14

OPERATION



WARNING!

Never start or stop engine with electrical devices plugged in to the receptacles. Failure to do so could damage the generator and / or connected electrical devices.

- Always start the engine and let it stabilize before connecting any electronic devices.
- Disconnect all electronic devices before stopping the engine.



WARNING!

Pull cord recoils rapidly and pulls arm towards engine faster than you can let go which could result in injury.

- To avoid recoil, pull starter cord slowly until resistance is felt, then pull rapidly.

Battery Charger for Electric Starter

Keep the generator battery fully charged and ready to use to avoid the need to use the recoil starter to start the generator manually.

How to Stop Engine (See fig 15-18)

- All loads **MUST** be disconnected from the generator. Never start or stop the engine with electrical devices plugged in to the receptacles. (See fig 15)

When using gasoline

1. Turn the engine START/ON/OFF switch to the "OFF" position. (See fig 18)
2. Turn the fuel valve lever back to the OFF position. (See fig 16)

When using LPG

1. Turn the engine START/ON/OFF switch to the "OFF" position. (See fig 18)
2. Turn off LPG bottle. (See fig 17)

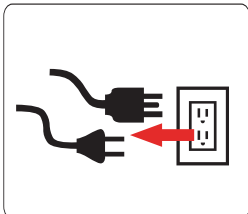

Fig 15

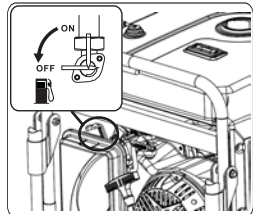

Fig 16

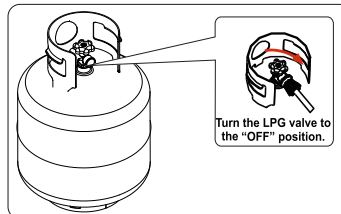

Fig 17

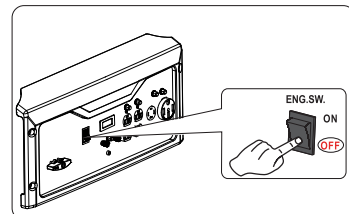

Fig 18

Receptacles and Extension Cords

Only use high quality, well-insulated, grounded extension cords in good condition with generator receptacles. Follow each load manufacturer's power rating recommendation when selecting receptacle and extension cord.

This generator is equipped with the following receptacles:

- Four 120 Volt AC, 20 Amp receptacles.
- 120 / 240 Volt AC, 50 Amp receptacle (NEMA L14-50R).
- 120 / 240 Volt AC, 30 Amp twist lock receptacle (NEMA L14-30).
- 12 Volt 8.3 Amp Output (For charging batteries only)

120 Volt AC, 20 Amp receptacle

- This receptacle has a 20 Amp push-to reset circuit breaker to protect against overload.
- Each socket is rated to operate 120 Volt, AC, single phase, 60Hz loads requiring up to 2400 watts (2.4 kW) at 20 Amps.
- Use extension cords having a minimum rating of 125 Volts AC, 20 Amps.

OPERATION

120 / 240 Volt AC, 30 Amp locking receptacle

- This receptacle has a 30 Amp push-to reset circuit breaker to protect against overload.
- This receptacle is rated to operate 120 Volt, AC, single phase, 60Hz loads requiring up to 3600 watts (3.6 kW) at 30 Amps. It is also rated to operate 240 Volt AC, single phase, 60Hz loads requiring up to 7,200 watts (7.2 kW).
- Use a NEMA L14-30 plug with this receptacle.
- Use a 4-wire cord rated for 240 Volts AC, 30 Amps to the plug. You can use the same 4-wire cord to operate a 120 Volt load.



CAUTION!

Do not connect 3-phase loads to generator.



WARNING!

12 Volt 8.3 Amp Output is for charging batteries only!

Extension Cord Selection

Refer to the below table to ensure the extension cord used has the capacity to carry the required load. If the size of the cable is inadequate it can cause a voltage drop, which can damage the electrical device and cord.

Current (Amps)	Load (Watts)	Maximum Cord Length				
		#8 Wire	#10 Wire	#12 Wire	#14 Wire	#16 Wire
2.5	600	X	1000 ft.	600 ft.	375 ft.	250 ft.
5	1200	X	500 ft.	300 ft.	200 ft.	125 ft.
7.5	1800	X	350 ft.	200 ft.	125 ft.	100 ft.
10	2400	X	250 ft.	150 ft.	100 ft.	50 ft.
15	3800	X	150 ft.	100 ft.	65 ft.	X
20	4800	175 ft.	125 ft.	75 ft.	X	X
25	6000	150 ft.	100 ft.	X	X	X
30	7200	125 ft.	65 ft.	X	X	X

Moving the Generator

- Disconnect any electronic devices from generator then turn generator off.
- Turn fuel valve to the "OFF" position.
- Tilt generator until it balances on wheels. Roll machine to desired location.
- If the generator must be carried, fold handle to the down position. Never lift or carry generator by its handle.



CAUTION!

This product is heavy and requires several people to lift. Lift and lower with your legs by bending at the knees, not your back, to avoid injury.

Don't Overload Generator

Make sure you can supply enough rated watts and surge watts for all electronic devices connected to the generator. Rated watts refer to the power a generator must supply to keep a device running. Surge watts refer to the power a generator must supply to start an electronic device. This power surge for starting a device usually lasts between 2-3 seconds but this additional output must be taken into account when selecting the electronic devices you plan to attach to the generator. To prevent overloading the generator take the following steps:

OPERATION

1. Add up the total rated wattage of all electronic devices that will be connected to the generator simultaneously.
2. Estimate surge watts by adding the item(s) with the highest output (it is unnecessary to calculate the surge output for all devices as they should be connected one at a time).
3. Add the Surge Watts to the total Rated Watts in step 1. Keep total load within generator's power capacity.

Operating voltage and frequency requirement of all electronic equipment should be checked prior to plugging them into this generator. Damage may result if the equipment is not designed to operate within a +/- 10% voltage variation, and +/- 3 Hz frequency variation from the generator name plate ratings. To reduce the risk of damage, always have an additional load plugged into the generator if solid state equipment (such as television set) is used. A power line conditioner is recommended for some solid state applications.

Wattage Reference Guide

(Wattages listed are just approximations. Check electronic device for actual wattage)

Essentials	Rated Watts	Surge Watts
75W Light Bulbs	75 each	75 each
18 CU Ft Refrigerator / Freezer	800	2200
Furnace Fan (1/3 HP)	800	2350
Sump Pump (1/3 HP)	1000	2000
Water Pump (1/3 HP)	1000	3000
Heating/Cooling		
Dehumidifier	650	800
Table Fan	800	2000
Window AC (10k BTU)	1200	3600
Central Air (10k BTU)	1500	6000
Electric Blanket	400	400
Space Heater	1800	1800
Kitchen		
Blender	300	900
Toaster (2 slice)	1000	1600
Coffee Maker	1500	1500
Electric Range (1 element)	1500	1500
Dishwasher	1500	3000
Electric Oven	3410	3410
Electric Water Heater	4000	4000
Laundry Room		
Iron	1200	1200
Washing Machine	1150	3400
Gas Clothes Dryer	700	2500
Electric Clothes Dryer	5400	6750

Bathroom	Rated Watts	Surge Watts
Hair Dryer	1250	0
Curling Iron	1500	0
Family Room		
X-Box or Play Station	40	0
AM/FM Radio	100	100
VCR	100	100
Color TV (27")	500	500
Home Office		
Fax Machine	65	0
Personal Computer (17" Monitor)	800	0
Laser Printer	950	0
Copy Machine	1600	0
Power Tools		
1000W Quartz Halogen Work Light	1000	0
Airless Sprayer (1/3 HP)	600	1200
Reciprocating Saw	960	0
Circular Saw (7 1/4")	1400	2300
Miter Saw (10")	1800	1800
Table/Radial Arm Saw	2000	2000
Electric Drill (1/2 HP, 5.4 Amps)	600	900
Hammer Drill	1000	3000
Air Compressor	1600	4500
Other		
Home Security System	500	500
Garage Door Opener (1/3 HP)	750	750



WARNING!

Never exceed generator's wattage / amperage capacity. This could damage the generator and / or connected electrical devices.

- Check operating voltage and frequency requirements of all electrical devices prior to plugging them into the generator.

OPERATION

Hour Meter (See Fig 19)

Use this meter along with the manual to determine when and what type of service on the unit is needed. The display will show the word “LUBE” at the first 25 hours of operation and again at every 100 hours of operation after.

Power Management

- Start engine without anything connected to generator.
- When engine has stabilized, plug in and turn on first load. It is strongly recommended to plug in devices with the largest output first and the smallest output last to help prevent overloading the generator.
- Allow generator output to stabilize (engine and attached devices run evenly) before plugging in the next load.

Charging a 12 Volt Battery (See Fig 20)

This generator can be used to charge a 12 volt automotive or storage battery by taking the following steps:

- Inspect fluid level of the battery cells.
- Add ONLY distilled water to any cell where fluid level is low. Never add tap water.
- Use a wire brush to clean battery terminals if corroded.
- Connect the Battery Charging Cable Connection Plug to the 12 Volt D.C. Receptacle.
- Connect the red cable clamp to the positive (+) battery terminal.
- Connect the black cable clamp to the negative (-) battery terminal.
- Start generator engine. Let engine run while battery charges.
- Battery is considered fully charged when the gravity of its fluid is 1.260 or higher when measured by a hydrometer. It is strongly recommended to use a hydrometer to test for battery charge and condition. Be careful to follow the hydrometer manufacturer’s instruction.

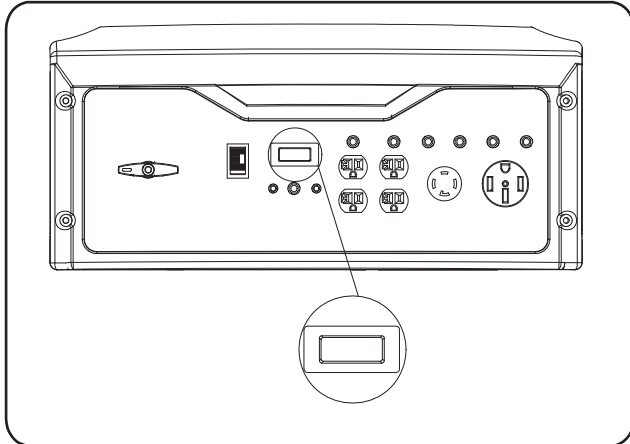

Fig 19

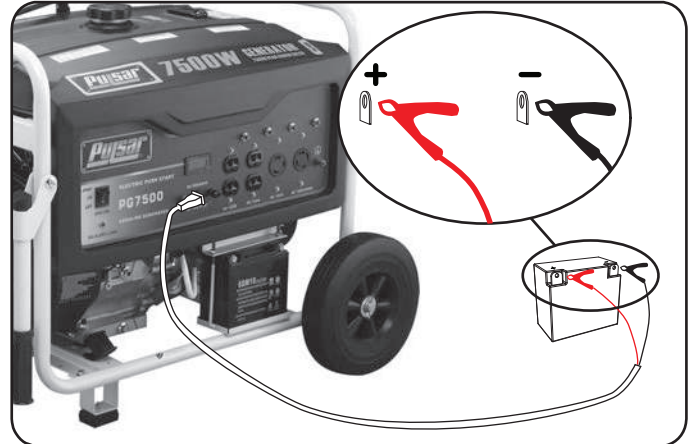

Fig 20

Cold Weather Operation

Under humid conditions where temperatures drop to 40°F (4°C) the carburetor and/or crankcase breather system may begin to freeze. To prevent icing take the following steps:

1. Replace any old fuel with clean, fresh fuel.
2. Use synthetic 5W-30 or SAE 5W-30 engine oil. Check oil daily or after every 8 hours of use.
3. Turn fuel valve to the open position.
4. Ensure generator is serviced according to the maintenance schedule under “Maintenance” section of manual.
5. Shelter unit from elements.

MAINTENANCE

Creating a Temporary Cold Weather Shelter

In an emergency, the original shipping carton can be used as a temporary shelter. The shelter should hold enough heat created by the generator to prevent icing.

1. Cut off all flaps.
2. Cut off one of the long sides of the carton to expose the units muffler and exhaust. Do not enclose the muffler / exhaust side of the generator.
3. Slide carton over generator. If necessary, remove the wheel assembly for fit.
4. Maintain 5 feet of clearance between the open side of box and other objects. The exposed side of the box should face away from the wind and elements.
5. Remove shelter when temperatures reach 40°F (4°C).

Regular maintenance will extend the life of this generator and improve its performance. The warranty does not cover items that result from operator negligence, misuse, or abuse. To receive full value from the warranty, operator must maintain the generator as instructed in this manual, including proper storage.



WARNING!

Before inspecting or servicing this machine, make sure the engine is off and no parts are moving. Disconnect the spark plug wire and move it away from the spark plug.

Pre-Operation Steps

Before starting the engine, perform the following pre-operation steps:

- Check the level of the engine oil and the fuel tank level.
- Make sure the air filter is clean.
- Remove any debris that has collected on the generator and around the muffler and controls. Use a vacuum cleaner to pick up loose debris. If dirt is caked on, use a soft bristle brush.
- Inspect the work area for hazards.

After Each Use

Follow the following procedure after each use:

- Shut off engine.)
- Store unit in a clean and dry area.

Maintenance Schedule

After First 5 Hours	Change Oil
After 8 Hours or Daily	Clean Debris
	Check Engine Oil Level
Annually (25 hr Use)	Check and Clean Air Cleaner
	Change Engine Oil (Service more often under dirty or dusty conditions)
	Check Muffler and Spark Arrester
Annually (100 hr Use)	Service Spark Plug (Replace with NGK BP6ES, Champion N9YC or equivalent)
	Service Fuel Valve
	Inspect Muffler and Spark Arrester
	Check and Clean Air Cleaner, Replace Air Filter
	Clean Cooling System

MAINTENANCE

Changing Oil (See Fig 21)

- Run the Generator until the Engine is warm.
- Place generator on a level surface.
- Remove the crankcase dipstick.
- Place an oil pan underneath the oil drainage bolt to collect used oil.
- Remove the oil drainage plug and allow oil to drain completely.
- Reinstall oil drainage plug, tighten securely.
- Carefully add SAE 10W-30 to empty reservoir until the oil reaches the outer edge of the oil fill hole (Crankcase Dipstick hole).
- Replace crankcase dipstick.

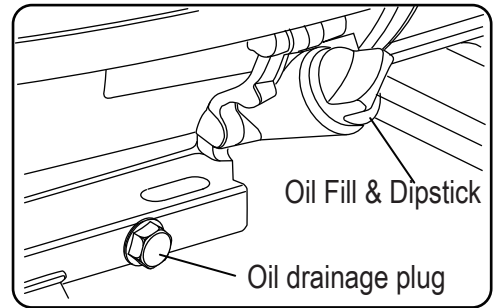
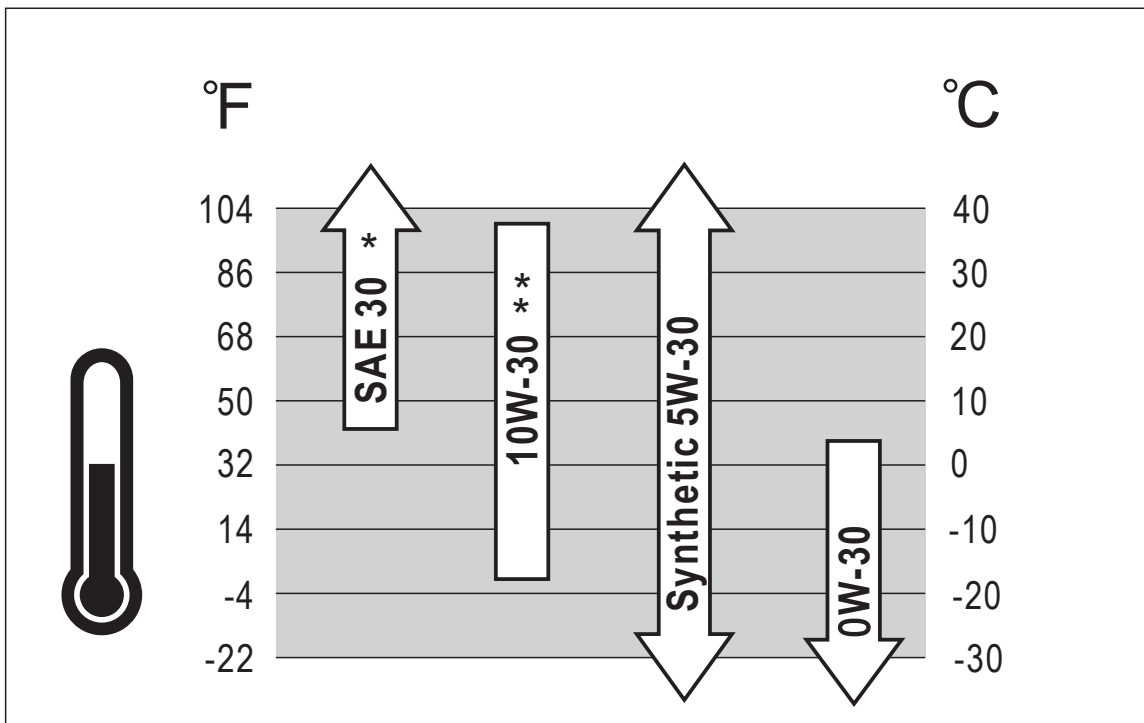

Fig 21

Oil Recommendations

- Do not use special additives.
- Outdoor temperatures determine the proper oil viscosity for the engine. Use the chart to select the best viscosity for the outdoor temperature range expected.



Note: * Below 40°F (4°C) the use of SAE 30 will result in hard starting.

** Above 80°F (27°C) the use of 10W-30 may cause increased oil consumption.
Check oil level more frequently.

MAINTENANCE



CAUTION!

Used oil should be disposed of at an approved disposal site. See your local oil retailer for more information.

Air Filter (See Fig 22)

A dirty air filter will reduce the life span of the engine, make it difficult to start the engine, and reduce the unit's performance.

- To clean, remove the air filter cover.
- Carefully pull the air filter out by lifting up along the edges.
- Remove dirt from filter by tapping on it or having it blown out. Replace with new filter annually.
- Reinstall air filter so that it seals and replace air filter cover.

Checking Spark Plug (See Fig 23)

- Disconnect the spark plug wire from the spark plug.
- Before removing the spark plug, clean the area around its base to prevent debris from entering the engine.
- Clean carbon deposits off the electrode with a wire brush.
- Check the electrode gap and slowly adjust to .700 mm - .80 mm (.028 - .031") if necessary.
- Reinstall spark plug and tighten to Torque 22.0 – 26.9 Nm (16-20 ft-lb).
- Reconnect spark plug wire.
- If spark plug is worn replace only with an equivalent replacement part. Spark plug should be replaced annually. (BOSCH F7TC, NGK BP6ES, CHAMPION N9YC or Equivalent)

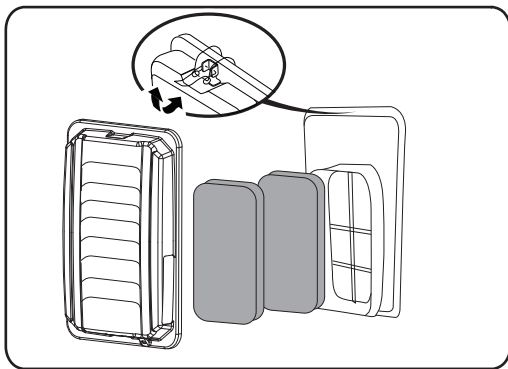

Fig 22

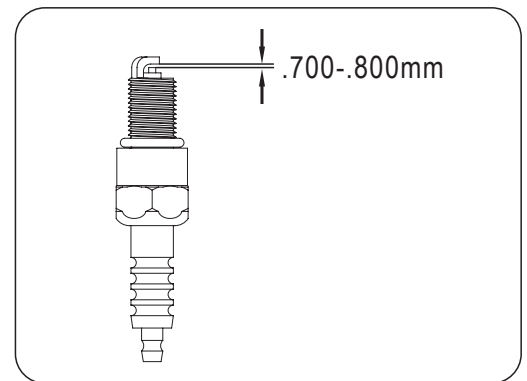

Fig 23

Spark Arrestor (See Fig 24)

- Inspect the spark arrestor for breaks or holes. Replace if necessary. To purchase a replacement spark arrestor contact PULSAR customer service.
- Use a brush to remove carbon deposits from the spark arrestor screen as needed.
- To remove the spark arrestor: While the muffler is cool, loosen the locking clamp and slide the spark arrestor out of the muffler. Reverse this process to install it.

Cooling System

Cooling system should only be serviced by an authorized dealer.

MAINTENANCE

High Altitude Operation

At high altitude, the standard carburetor air/fuel mixture will be too rich. Performance will decrease, and fuel consumption will increase. A very rich mixture will also foul the spark plug and cause hard starting. Operation at an altitude that differs from that at which this engine was certified, for extended periods of time, may increase emissions. High altitude performance can be improved by specific

modifications to the carburetor. If you always operate your generator at altitudes above 5,000 feet (1,500 meters), have your dealer perform this carburetor modification. This engine, when operated at high altitude with the carburetor modifications for high altitude use, will meet each emission standard throughout its useful life. Even with carburetor modification, engine horsepower will decrease about 3.5% for each 1,000-foot (300-meter) increase in altitude. The effect of altitude on horsepower will be greater than this if no carburetor modification is made.

Replacing Fuel Filter (See Fig 25 If Applicable)

Occasionally the fuel filter may become clogged and need replacing. To purchase a replacement fuel filter contact PULSAR customer service or your local small Engine repair shop.

- Turn the fuel valve to the “OFF” position.
- Remove the fuel line from both sides of the filter by squeezing the ends of the retaining clip with pliers.
- Slide the fuel line off.
- Replace with new fuel filter.
- Reinstall fuel lines to new fuel filter.
- Turn the fuel valve to the “ON” position.

CAUTION! Fuel tank must be empty before replacing fuel filter. Run unit until tank is empty, if needed, or inspect filter prior to fill-up.

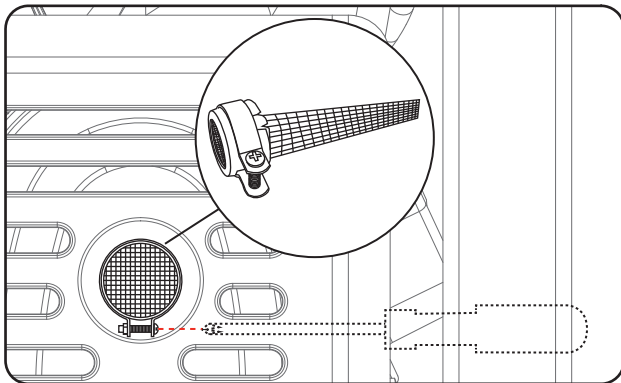

Fig 24

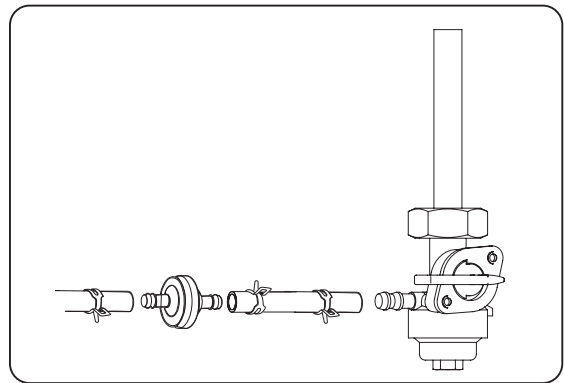

Fig 25

Draining Fuel Tank and Carburetor

To help prevent gum deposits in the fuel system, drain the fuel from the tank and carburetor before storing the unit for long periods of time. This will help prevent starting problems in the future. If the unit is stored with fuel and the fuel becomes stale or turns gummy or to varnish the warranty does not cover this repair or service.

Draining the fuel tank

- Turn the engine OFF.
- Turn the fuel valve to the OFF position.
- Remove the fuel line that leads to the carburetor from the petcock by squeezing the ends of the hose clamps and sliding the fuel line off.
- If needed, install a fuel hose that will extend to a suitable fuel container large enough to catch the fuel being drained from the tank.
- Turn the fuel valve to the ON position.
- When the fuel has drained from the tank, close the fuel valve and reinstall fuel line securely on petcock.

MAINTENANCE

Draining the carburetor

- Turn the engine OFF.
- Turn the fuel valve to the OFF position.
- Position a suitable container under the carburetor drain screw to catch fuel; loosen the screw.
- Allow fuel to drain completely into container.
- Retighten drain screw.



CAUTION!

Consult your local hazardous waste management in your area for the proper way to dispose of used fuel.

Storage and Transportation of the Generator: (See Fig 26)

- Remove any debris that has collected on the generator and around the muffler and control panel. Use a brush or vacuum to remove loose dirt.
- Inspect air cooling slots. Remove any debris if obstructed.
- For short-term storage, start generator once every 7 days.
- For semi-long term storage, add fuel stabilizer to prevent stale fuel from causing acid and gum deposits in the fuel system and carburetor.
- For long-term storage, drain the fuel.
- Store the generator indoors to prevent freezing.
- The generator must be Shipped, Run and Stored in the upright position as seen in this image.

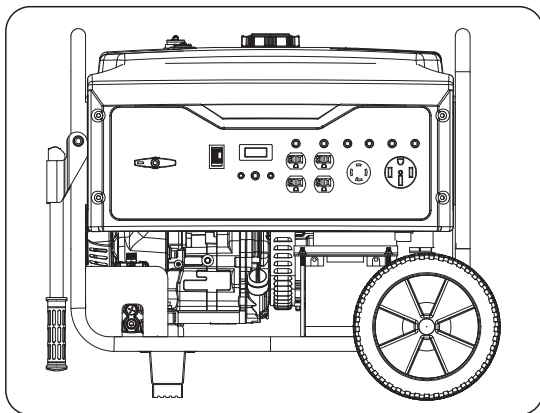

Fig 26

Engine Long Term Storage:

- Remove the spark plug and pour about 1 teaspoon of 10W30 Engine oil into the spark plug hole. Reinstall the spark plug. With the ON/OFF switch in the OFF position pull the recoil starter cord several time to coat the cylinder walls with oil.
- Slowly pull the recoil Starter until you feel the engine build compression (When you feel resistance). Leave the Engine in this state as this will prevent any corrosion on the cylinder walls if stored for a long period of time.

TROUBLESHOOTING

Problem	Cause	Solution
Engine is running, but AC output is not available	<ol style="list-style-type: none"> 1. Open circuit breaker 2. Poor connection 3. Defective cord set 4. Connected device is faulty 5. Fault in generator 	<ol style="list-style-type: none"> 1. Reset circuit breaker 2. Check and repair 3. Check and repair 4. Connect a device that is working properly 5. Contact service department
Engine runs well without load but bogs down when loads are connected	<ol style="list-style-type: none"> 1. Short circuit in connected device 2. Generator is overloaded 3. Clogged fuel filter 4. Engine speed is too slow 5. Short circuit in generator 	<ol style="list-style-type: none"> 1. Disconnect device 2. See pg 15 "Don't overload generator" 3. Clean or replace fuel filter 4. Contact service department 5. Contact service department
Engine will not start, shuts down during operation, or starts and runs rough.	<ol style="list-style-type: none"> 1. ON/OFF switch set to "OFF" 2. Dirty Air filter 3. Clogged fuel filter 4. Stale fuel 5. Spark plug wire disconnected from spark plug 6. Bad spark plug 7. Water in fuel 8. Fuel valve is in "OFF" position 9. Over choking 10. Low oil level 11. Rich fuel mixture 12. Intake valve stuck open or closed 13. Loss of engine compression 14. Dead battery 15. Engine has flooded 	<ol style="list-style-type: none"> 1. Turn switch to "ON" 2. Replace Air filter 3. Clean or replace fuel filter 4. Replace fuel 5. Reconnect spark plug wire 6. Replace spark plug 7. Drain fuel tank and replace fuel 8. Turn fuel valve to "ON" position 9. Turn off choke 10. Fill crankcase to proper oil level & place generator on a level surface 11. Contact service department 12. Contact service department 13. Contact service department 14. Recharge or replace battery 15. Wait 5 minutes and re crank engine
Engine lacks power	<ol style="list-style-type: none"> 1. Generator is overloaded 2. Clogged fuel filter 3. Dirty Air filter 4. Engine needs servicing 	<ol style="list-style-type: none"> 1. See pg 15 "Don't overload generator" 2. Clean or replace fuel filter 3. Replace Air filter 4. Contact service department
Engine "hunts" or falters	<ol style="list-style-type: none"> 1. Choke was removed too soon 2. Clogged fuel filter 3. Carburetor is running too rich or too lean 	<ol style="list-style-type: none"> 1. Move choke to middle position until engine runs evenly 2. Clean or replace fuel filter 3. Contact service department

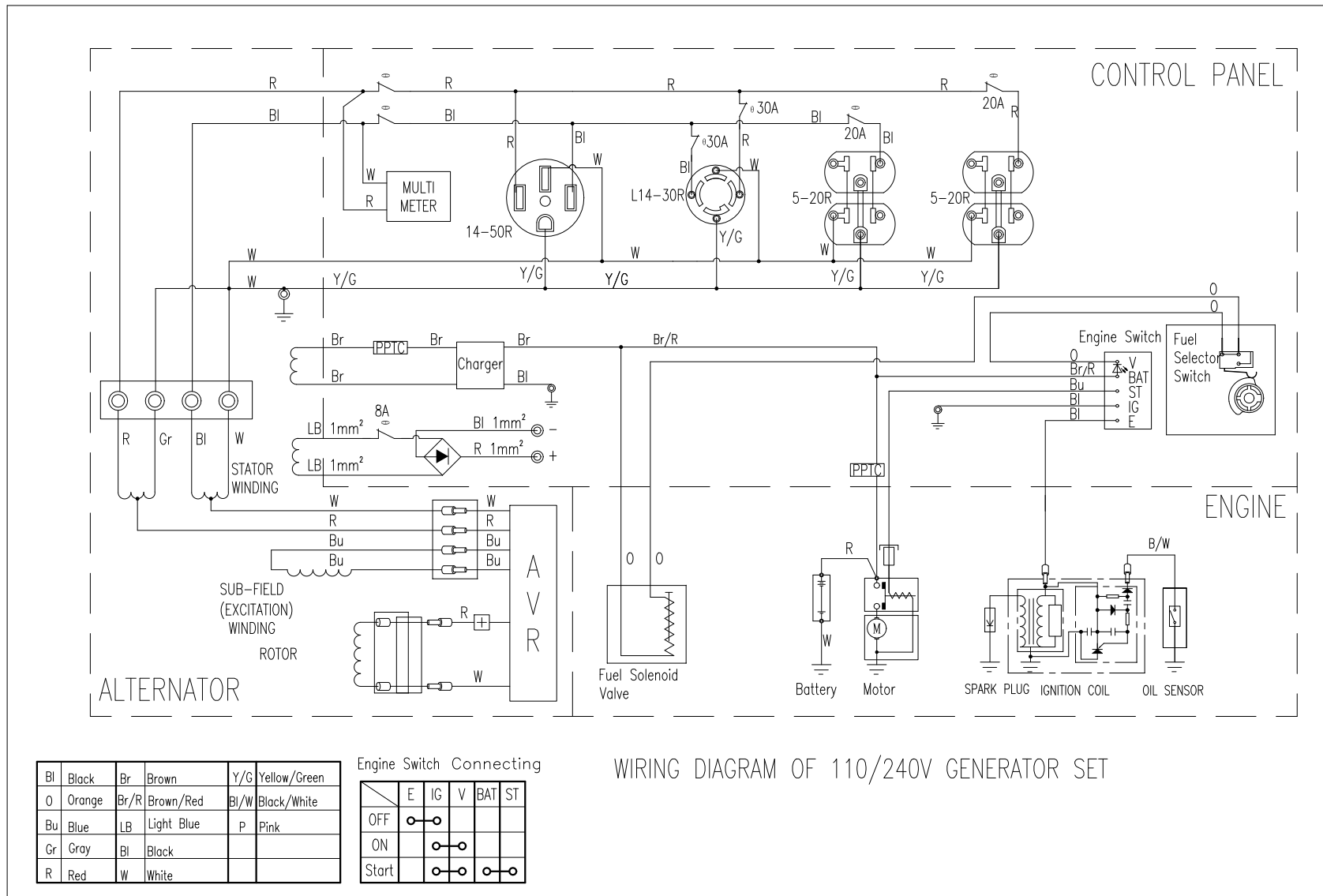

Bl	Black	Br	Brown	Y/G	Yellow/Green
O	Orange	Br/R	Brown/Red	Bl/W	Black/White
Bu	Blue	LB	Light Blue	P	Pink
Gr	Gray	Bl	Black		
R	Red	W	White		

Engine Switch Connecting

	E	IG	V	BAT	ST
OFF	○	○	○	○	○
ON	○	○	○	○	○
Start	○	○	○	○	○

WIRING DIAGRAM OF 110/240V GENERATOR SET

WARRANTY

Pulsar Products Inc. Limited 2 Year Warranty:

From the date of original purchase, **Pulsar Products Inc.** warrants to the original purchaser that each portable generator sold, shall be free from defect in material and workmanship for the items and time period set forth below. **Pulsar Products Inc.**, at its discretion, agrees to repair or replace any defective part that upon examination, inspection, and testing by a **Pulsar Products Inc.** authorized service dealer, is found to be defective within the original warranty period. **Pulsar Products Inc.** will also decide upon the use of new or rebuilt parts or comparable product. Any part or product that is replaced will be retained by **Pulsar Products Inc.**. This warranty period shall not be extended and any repaired product shall be warranted for the remaining period of the original warranty. The consumer is responsible, and shall prepay all transportation costs, including returning items to the factory or warehouse. This warranty is non-transferable and proof of purchase must be presented for requesting warranty service. If a proof-of-purchase receipt is not provided, the product's shipping date by the manufacturer will be used to determine the warranty period.

Length of Warranty:

Personal use applications of this portable generator are warranted for two (2) years or 500 hours which ever comes first. Proof of purchase and of maintenance must be provided.

- Year 1 - Limited coverage on generator engine and alternator components parts and labor.
- Year 2 - Limited coverage on generator engine components, parts only.

"Personal use" means personal residential household use or recreational use by the retail consumer. "Commercial use" means all other uses including commercial, construction, or other income producing purposes. Once a generator has been used for commercial purposes, it shall thereafter be considered as a "commercial use" generator for the purposes of this warranty. Any portable generator used for commercial use, as rental equipment or for the purpose of primary power in place of utility, will not be covered under this warranty.

Consumer Responsibilities:

- Consumer is responsible for carefully reading and following all instructions in the owner's manual. Any product that is damaged due to misuse or abuse will not be covered by this warranty.
- Consumer is responsible for all transportation costs to an authorized **Pulsar Products Inc.** Service Center. Unless otherwise requested, ground shipping will be applied for part shipment and customer will pay any additional charges for expedited shipments.
- Consumer is responsible for labor costs associated with warranted repairs twelve (12) months after the purchase date. Labor rates will only be based on normal working hours.
- Consumer is responsible for maintaining generator as specified in the owner's manual. Documentation of this maintenance may be required to cover warranty requests.
- Consumer is responsible for presenting any problems with the generator to an authorized **Pulsar Products Inc.** Service Center as soon as the problem exists. Warranted repairs will be completed in a reasonable period of time, not to exceed 30 days.

WARRANTY

What this Warranty Does Not Cover:

- **Normal wear:** This warranty excludes normal wear items such as filters, spark plugs, gaskets, O-rings, adapter cord sets, wheels, and starting batteries.
- **Maintenance:** This warranty does not apply to tune-ups or routine maintenance and does not cover any adjustments or repairs not performed by an authorized repair facility.
- **Misuse:** This warranty does not apply if your product has failed due to abuse, misuse, neglect, using incorrect fuels or lubricants, overloading, overspeeding, improper maintenance, improper storage, unapproved modifications, or has been operated in any way contrary to the instructions found in the products owner's manual.
- **Adverse conditions:** This warranty does not apply if your product has failed due to freezing, accident or natural disasters.
- **Product shipment:** This warranty does not apply to damage resulting from shipping, handling, or warehousing. Any damage claims to this product caused by shipment must be filed with freighter.
- **Other exclusions:** This warranty does not apply if your product has been sold "as is" or where the factory applied serial number has been removed. Refurbished, used, demonstration or floor models are not covered by this warranty.

Where Warranty is Valid:

For warranty coverage, this product must be purchased from an authorized **Pulsar Products Inc.** dealer and the warranty only extends to the original purchaser in the United States, Canada, or Mexico. Refurbished, used, demonstration, or floor models are not covered by this warranty. Products purchased from on-line auction websites, such as ebay, are not covered under this warranty. Products used for commercial use are not covered under this warranty.

How to Obtain Warranty Service:

Take the original receipt and product to the place of purchase or mail the original receipt and product to the address found on the web site if purchased on-line. You can also locate your nearest **Pulsar Products Inc.** dealer for service or warranty questions by calling toll free at 1-866-591-8921. **Pulsar Products Inc.** recommends you retain all of your receipts covering the purchase and maintenance of your Portable Generator, but will not deny you warranty coverage as long as proof of purchase or service can be obtained.

Pulsar Products Inc.'s obligation under this warranty is exclusively limited to product repair or replacement and shall not be liable for any incidental or consequential damages including, but not limited to, the expense of delivering product to and from a repair center, loss or damage to personal property, loss of revenue, telephone charges, loss of time, or inconvenience. Some states, provinces or jurisdictions do not allow the exclusion or limitation of incidental damages, so the above limitation may not apply to you. The warranty gives you specific legal rights, and you may also have other rights which vary from state to state or province to province.

Image of products may slightly differ due to continued improvement of product.