



OM-289543G

2024-09

Processes



Stick (SMAW) Welding

Description



Engine Driven Welder/Generator

# Champion<sup>®</sup> Elite 225

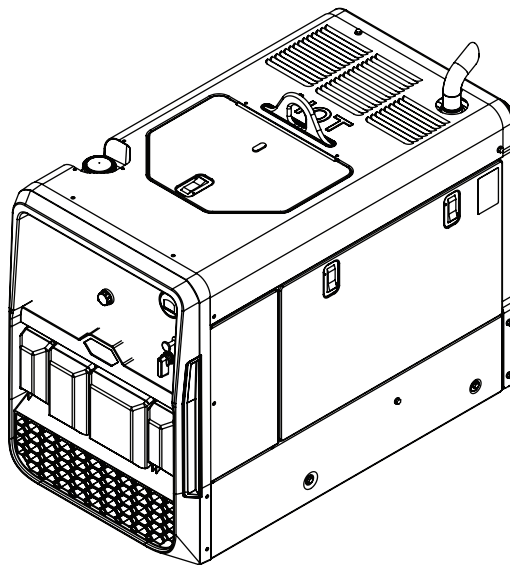

Find us on

YouTube

[www.HobartWelders.com](http://www.HobartWelders.com)

**OWNER'S MANUAL**

# From Hobart to You

---

*Thank you and congratulations* on choosing Hobart. Now you can get the job done and get it done right. We know you don't have time to do it any other way.

This Owner's Manual is designed to help you get the most out of your Hobart products. Please take time to read the Safety Precautions. They will help you protect yourself against potential hazards on the worksite. We've made installation and operation quick and easy. With Hobart, you can count on years of reliable service with proper maintenance. And if for some reason the unit needs repair, there's a Troubleshooting section that will help you figure out what the problem is. The parts list will then help you to decide the exact part you may need to fix the problem. Warranty and service information for your particular model are also provided.

Hobart Welders manufactures a full line of welders and welding-related equipment. For information on other quality Hobart products, contact your local Hobart distributor to receive the latest full line catalog or individual specification sheets. **To locate your nearest distributor or service agency call 1-800-332-3281, or visit us at [www.HobartWelders.com](http://www.HobartWelders.com) on the web.**



For Technical Help call 1-800-332-3281.

Register your product at [www.HobartWelders.com](http://www.HobartWelders.com)



Hobart is registered to the ISO 9001 Quality System Standard.



# TABLE OF CONTENTS

<b>SECTION 1 – SAFETY PRECAUTIONS – READ BEFORE USING</b>	<b>1</b>
1-1 Symbol Usage	1
1-2 Arc Welding Hazards	1
1-3 Engine Hazards	3
1-4 Compressed Air Hazards	4
1-5 Additional Hazards For Installation, Operation, And Maintenance	4
1-6 California Proposition 65 Warnings	6
1-7 Principal Safety Standards	6
1-8 EMF Information	6
<b>SECTION 2 – CONSIGNES DE SÉCURITÉ - LIRE AVANT UTILISATION</b>	<b>7</b>
2-1 Symboles utilisés	7
2-2 Dangers relatifs au soudage à l'arc	7
2-3 Dangers existant en relation avec le moteur	9
2-4 Dangers liés à l'air comprimé	10
2-5 Symboles de dangers supplémentaires en relation avec l'installation, le fonctionnement et la maintenance	11
2-6 Proposition californienne 65 Avertissements	13
2-7 Principales normes de sécurité	13
2-8 Informations relatives aux CEM	14
<b>SECTION 3 – DEFINITIONS</b>	<b>15</b>
3-1 Additional Safety Symbol Definitions	15
3-2 Miscellaneous Symbol Definitions	15
<b>SECTION 4 – SPECIFICATIONS</b>	<b>17</b>
4-1 Serial Number And Rating Label Location	17
4-2 Information About Default Weld Parameters And Settings	17
4-3 Weld, Power, And Carbureted Engine Specifications	17
4-4 Environmental Specifications	17
4-5 Base Unit Dimensions, Weights, And Operating Angles	18
4-6 Duty Cycle And Overheating	19
4-7 Volt-Ampere Curves	19
4-8 Fuel Consumption	20
<b>SECTION 5 – INSTALLATION</b>	<b>21</b>
5-1 Installing Welder/Generator	21
5-2 Grounding Generator to Truck or Trailer Frame	22
5-3 Ground Cable Routing	22
5-4 Installing Exhaust Pipe	23
5-5 Engine Prestart Checks	24
5-6 Connecting Or Replacing The Battery	25
5-7 Weld Output Terminals	26
5-8 Connecting Weld Output Cables	26
5-9 Selecting Cable Sizes*	27
<b>SECTION 6 – OPERATION</b>	<b>28</b>
6-1 Front Panel Controls	28
6-2 Fuel/Hour Gauge Descriptions	29
6-3 Typical Stick Welding Connections And Control Settings	29
6-4 Cold Weather Engine Operation	30
<b>SECTION 7 – OPERATING AUXILIARY EQUIPMENT</b>	<b>31</b>
7-1 Generator Power Receptacles	31
7-2 GFCI Receptacle Information, Resetting, And Testing	32
7-3 Simultaneous Weld And Power	33
7-4 Wiring Instructions For 240 Volt, Single-Phase Plug (NEMA 14-50P)	33
7-5 Wiring Instructions For 240 Volt, Single-Phase Plug (NEMA 6-50P)	34
<b>SECTION 8 – MAINTENANCE AND TROUBLESHOOTING</b>	<b>35</b>
8-1 Routine Maintenance	35
8-2 Maintenance Label	36
8-3 Servicing Air Cleaner	37
8-4 Overload Protection	38
8-5 Changing Engine Oil, Oil Filter, And Fuel Filter	39
8-6 Adjusting Engine Speed	40
8-7 Fault Indicator	41
8-8 Servicing Optional Spark Arrestor	41
8-9 Troubleshooting	42
<b>SECTION 9 – PARTS LIST</b>	<b>44</b>

# TABLE OF CONTENTS

---

9-1	Recommended Spare Parts .....	44
<b>SECTION 10 – ELECTRICAL DIAGRAMS .....</b>		<b>46</b>
<b>SECTION 11 – GENERATOR POWER GUIDELINES .....</b>		<b>48</b>
11-1	Selecting Equipment .....	48
11-2	Grounding When Supplying Building Systems .....	48
11-3	How Much Power Does Equipment Require? .....	49
11-4	Approximate Power Requirements For Industrial Motors .....	49
11-5	Approximate Power Requirements For Farm/Shop Equipment .....	50
11-6	Approximate Power Requirements For Contractor Equipment .....	51
11-7	Power Required To Start Motor .....	52
11-8	How Much Power Can Generator Supply? .....	52
11-9	Typical Connections To Standby Power .....	53
11-10	Selecting Extension Cord (Use Shortest Cord Possible) .....	53
<b>SECTION 12 – STICK WELDING (SMAW) GUIDELINES .....</b>		<b>55</b>

# SECTION 1 – SAFETY PRECAUTIONS – READ BEFORE USING

 Protect yourself and others from injury—read, follow, and save these important safety precautions and operating instructions.

## 1-1. Symbol Usage

 **DANGER!** – Indicates a hazardous situation which, if not avoided, will result in death or serious injury. The possible hazards are shown in the adjoining symbols or explained in the text.

 Indicates a hazardous situation which, if not avoided, could result in death or serious injury. The possible hazards are shown in the adjoining symbols or explained in the text.

**NOTICE** – Indicates statements not related to personal injury.

 Indicates special instructions.



This group of symbols means Warning! Watch Out! ELECTRIC SHOCK, MOVING PARTS, and HOT PARTS hazards. Consult symbols and related instructions below for necessary actions to avoid these hazards.

## 1-2. Arc Welding Hazards

 The symbols shown below are used throughout this manual to call attention to and identify possible hazards. When you see the symbol, watch out, and follow the related instructions to avoid the hazard. The safety information given below is only a summary of the more complete safety information found in the Principal Safety Standards. Read and follow all Safety Standards.

 Only qualified persons should install, operate, maintain, and repair this equipment. A qualified person is defined as one who, by possession of a recognized degree, certificate, or professional standing, or who by extensive knowledge, training and experience, has successfully demonstrated the ability to solve or resolve problems relating to the subject matter, the work, or the project and has received safety training to recognize and avoid the hazards involved.

 During operation, keep everybody, especially children, away.



### ELECTRIC SHOCK can kill.

Touching live electrical parts can cause fatal shocks or severe burns. The electrode and work circuit is electrically live whenever the output is on. The input power circuit and machine internal circuits

are also live when power is on. In semiautomatic or automatic wire welding, the wire, wire reel, drive roll housing, and all metal parts touching the welding wire are electrically live. Incorrectly installed or improperly grounded equipment is a hazard.

- Do not touch live electrical parts.
- Wear dry, hole-free insulating gloves and body protection.
- Insulate yourself from work and ground using dry insulating mats or covers big enough to prevent any physical contact with the work or ground.
- Do not use AC weld output in damp, wet, or confined spaces, or if there is a danger of falling.
- Do not store or use equipment in standing water.
- Use AC output ONLY if required for the welding process.
- If AC output is required, use remote output control if present on unit.
- Additional safety precautions are required when any of the following electrically hazardous conditions are present: in damp locations or while wearing wet clothing; on metal structures such as floors, gratings, or scaffolds; when in cramped positions such as sitting, kneeling, or lying; or when there is a high risk of unavoidable or accidental contact with the workpiece or ground. For these conditions, use the following equipment in order presented: 1) a semiautomatic DC constant voltage (wire) welder, 2) a DC manual (stick) welder, or 3) an AC welder with reduced open-circuit voltage. In most situations, use of a DC, constant voltage wire welder is recommended. And, do not work alone!

- Do not connect to any electrical distribution system normally supplied by utility power unless a proper transfer switch and grounding procedure are employed.
- Disconnect input power or stop engine before installing or servicing this equipment. Lockout/tagout input power according to OSHA 29 CFR 1910.147 (see Safety Standards).
- Properly install, ground, and operate this equipment according to its Owner's Manual and national, state, and local codes.
- Always verify the supply ground—check and be sure that input power cord ground wire is properly connected to ground terminal in disconnect box or that cord plug is connected to a properly grounded receptacle outlet.
- When making input connections, attach proper grounding conductor first—double-check connections.
- Keep cords dry, free of oil and grease, and protected from hot metal and sparks.
- Frequently inspect input power cord and ground conductor for damage or bare wiring—replace immediately if damaged—bare wiring can kill.
- Turn off all equipment when not in use.
- Do not use worn, damaged, undersized, or repaired cables.
- Do not drape cables over your body.
- If earth grounding of the workpiece is required, ground it directly with a separate cable.
- Do not touch electrode if you are in contact with the work, ground, or another electrode from a different machine.
- Use only well-maintained equipment. Repair or replace damaged parts at once. Maintain unit according to manual.
- Do not touch electrode holders connected to two welding machines at the same time since double open-circuit voltage will be present.
- Wear a safety harness if working above floor level.
- Keep all panels and covers securely in place.
- Clamp work cable with good metal-to-metal contact to workpiece or worktable as near the weld as practical.
- Insulate work clamp when not connected to workpiece to prevent contact with any metal object.
- Do not connect more than one electrode or work cable to any single weld output terminal. Disconnect cable for process not in use.
- Use GFCI protection when operating auxiliary equipment. Test GFCI receptacles at high speed.



### HOT PARTS can burn.

- Do not touch hot parts bare handed.
- Allow cooling period before working on equipment.
- To handle hot parts, use proper tools and/or wear heavy, insulated welding gloves and clothing to

prevent burns.

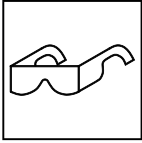

### FLYING METAL OR DIRT can injure eyes.

- Welding, chipping, wire brushing, and grinding cause sparks and flying metal. As welds cool, they can throw off slag.
- Wear approved safety glasses with side shields even under your welding helmet.



### FUMES AND GASES can be hazardous.

Welding produces fumes and gases. Breathing these fumes and gases can be hazardous to your health.

- Keep your head out of the fumes. Do not breathe the fumes.
- Ventilate the work area and/or use local forced ventilation at the arc to remove welding fumes and gases. The recommended way to determine adequate ventilation is to sample for the composition and quantity of fumes and gases to which personnel are exposed.
- If ventilation is poor, wear an approved air-supplied respirator.
- Read and understand the Safety Data Sheets (SDSs) and the manufacturer's instructions for adhesives, coatings, cleaners, consumables, coolants, degreasers, fluxes, and metals.
- Work in a confined space only if it is well ventilated, or while wearing an air-supplied respirator. Always have a trained watchperson nearby. Welding fumes and gases can displace air and lower the oxygen level causing injury or death. Be sure the breathing air is safe.
- Do not weld in locations near degreasing, cleaning, or spraying operations. The heat and rays of the arc can react with vapors to form highly toxic and irritating gases.
- Do not weld on coated metals, such as galvanized, lead, or cadmium plated steel, unless the coating is removed from the weld area, the area is well ventilated, and while wearing an air-supplied respirator. The coatings and any metals containing these elements can give off toxic fumes if welded.



### BUILDUP OF GAS can injure or kill.

- Shut off compressed gas supply when not in use.
- Always ventilate confined spaces or use approved air-supplied respirator.



### ARC RAYS can burn eyes and skin.

Arc rays from the welding process produce intense visible and invisible (ultraviolet and infrared) rays that can burn eyes and skin. Sparks fly off from the weld.

- Wear an approved welding helmet fitted with a proper shade of filter lenses to protect your face and eyes from arc rays and sparks when welding or watching (see ANSI Z49.1 and Z87.1 listed in Safety Standards).
- Wear approved safety glasses with side shields under your helmet.
- Use protective screens or barriers to protect others from flash, glare, and sparks; warn others not to watch the arc.
- Wear body protection made from leather or flame-resistant clothing (FRC). Body protection includes oil-free clothing such as leather gloves, heavy shirt, cuffless trousers, high shoes, and a cap.



### WELDING can cause fire or explosion.

Welding on closed containers, such as tanks, drums, or pipes, can cause them to blow up. Sparks can fly off from the welding arc. The flying sparks, hot workpiece, and hot equipment can cause fires and burns.

Accidental contact of electrode to metal objects can cause sparks, explosion, overheating, or fire. Check and be sure the area is safe before doing any welding.

- Remove all flammables within 35 ft (10.7 m) of the welding arc. If this is not possible, tightly cover them with approved covers.
- Do not weld where flying sparks can strike flammable material.
- Protect yourself and others from flying sparks and hot metal.
- Be alert that welding sparks and hot materials from welding can easily go through small cracks and openings to adjacent areas.
- Watch for fire, and keep a fire extinguisher nearby.
- Be aware that welding on a ceiling, floor, bulkhead, or partition can cause fire on the hidden side.
- Do not cut or weld on tire rims or wheels. Tires can explode if heated. Repaired rims and wheels can fail. See OSHA 29 CFR 1910.177 listed in Safety Standards.
- Do not weld on containers that have held combustibles, or on closed containers such as tanks, drums, or pipes unless they are properly prepared according to AWS F4.1 (see Safety Standards).
- Do not weld where the atmosphere can contain flammable dust, gas, or liquid vapors (such as gasoline).
- Connect work cable to the work as close to the welding area as practical to prevent welding current from traveling long, possibly unknown paths and causing electric shock, sparks, and fire hazards.
- Do not use welder to thaw frozen pipes.
- Remove stick electrode from holder or cut off welding wire at contact tip when not in use.
- Wear body protection made from leather or flame-resistant clothing (FRC). Body protection includes oil-free clothing such as leather gloves, heavy shirt, cuffless trousers, high shoes, and a cap.
- Remove any combustibles, such as a butane lighter or matches, from your person before doing any welding.
- After completion of work, inspect area to ensure it is free of sparks, glowing embers, and flames.
- Use only correct fuses or circuit breakers. Do not oversize or bypass them.
- Follow requirements in OSHA 1910.252 (a) (2) (iv) and NFPA 51B for hot work and have a fire watcher and extinguisher nearby.
- Read and understand the Safety Data Sheets (SDSs) and the manufacturer's instructions for adhesives, coatings, cleaners, consumables, coolants, degreasers, fluxes, and metals.

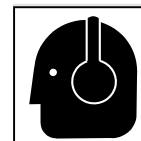

### NOISE can damage hearing.

Noise from some processes or equipment can damage hearing.

- Wear approved ear protection if noise level is high.



### ELECTRIC AND MAGNETIC FIELDS (EMF) can affect Implanted Medical Devices.

- Wearers of Pacemakers and other Implanted Medical Devices should keep away.
- Implanted Medical Device wearers should consult their doctor and the device manufacturer before going near arc welding, spot welding, gouging, plasma arc cutting, or induction heating operations.

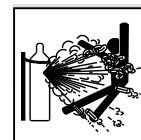

### CYLINDERS can explode if damaged.

Compressed gas cylinders contain gas under high pressure. If damaged, a cylinder can explode. Since gas cylinders are normally part of the welding process, be sure to treat them carefully.

- Protect compressed gas cylinders from excessive heat, mechanical shocks, physical damage, slag, open flames, sparks, and arcs.

- Install cylinders in an upright position by securing to a stationary support or cylinder rack to prevent falling or tipping.
- Keep cylinders away from any welding or other electrical circuits.
- Never drape a welding torch over a gas cylinder.
- Never allow a welding electrode to touch any cylinder.
- Never weld on a pressurized cylinder—explosion will result.
- Use only correct compressed gas cylinders, regulators, hoses, and fittings designed for the specific application; maintain them and associated parts in good condition.

- Turn face away from valve outlet when opening cylinder valve. Do not stand in front of or behind the regulator when opening the valve.
- Keep protective cap in place over valve except when cylinder is in use or connected for use.
- Use the proper equipment, correct procedures, and sufficient number of persons to lift, move, and transport cylinders.
- Read and follow instructions on compressed gas cylinders, associated equipment, and Compressed Gas Association (CGA) publication P-1 listed in Safety Standards.

### 1-3. Engine Hazards



#### **BATTERY EXPLOSION can injure.**

- Always wear a face shield, rubber gloves, and protective clothing when working on a battery.
- Stop engine before disconnecting or connecting battery cables, battery charging cables (if applicable), or servicing battery.
- Do not allow tools to cause sparks when working on a battery.
- Do not use welder to charge batteries or jump start vehicles unless the unit has a battery charging feature designed for this purpose.
- Observe correct polarity (+ and -) on batteries.
- Disconnect negative (-) cable first and connect it last.
- Keep sparks, flames, cigarettes, and other ignition sources away from batteries. Batteries produce explosive gases during normal operation and when being charged.
- Follow battery manufacturer's instructions when working on or near a battery. See Battery Service Manual (listed in Safety Standards) for additional information.



#### **FUEL can cause fire or explosion. ENGINE HEAT can cause fire.**

- Stop engine and let it cool off before checking or adding fuel.
- Do not add fuel while smoking or if unit is near any sparks or open flames.
- Do not overfill tank — allow room for fuel to expand.
- Do not spill fuel. If fuel is spilled, clean up before starting engine.
- Dispose of rags in a fireproof container.
- Always keep nozzle in contact with tank when fueling.
- Do not locate unit on, over, or near combustible surfaces or flammables.
- Keep exhaust and exhaust pipes way from flammables.



#### **MOVING PARTS can injure.**

- Keep away from moving parts such as fans, belts, and rotors.
- Keep all doors, panels, covers, and guards closed and securely in place.
- Stop engine before installing or connecting unit.
- Have only qualified persons remove doors, panels, covers, or guards for maintenance and troubleshooting as necessary.
- To prevent accidental starting during servicing, disconnect negative (-) battery cable from battery.
- Keep hands, hair, loose clothing, and tools away from moving parts.
- Reinstall doors, panels, covers, or guards when servicing is finished and before starting engine.

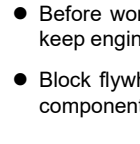

#### **EXHAUST SPARKS can injure.**

- Before working on generator, remove spark plugs or injectors to keep engine from kicking back or starting.
- Block flywheel so that it will not turn while working on generator components.
- Do not let engine exhaust sparks cause fire.
- Use approved engine exhaust spark arrestor in required areas — see applicable codes.



#### **HOT PARTS can burn.**

- Do not touch hot parts bare handed.
- Allow cooling period before working on equipment.
- To handle hot parts, use proper tools and/or wear heavy, insulated welding gloves and clothing to prevent burns.

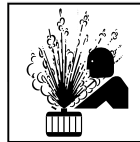

#### **STEAM AND HOT COOLANT can burn.**

- If possible, check coolant level when engine is cold to avoid scalding.
- Always check coolant level at overflow tank, if present on unit, instead of radiator (unless told otherwise in maintenance section or engine manual).
- If the engine is warm, checking is needed, and there is no overflow tank, follow the next two statements.
- Wear safety glasses and gloves and put a rag over radiator cap.
- Turn cap slightly and let pressure escape slowly before completely removing cap.

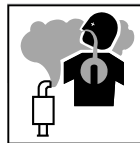

#### **Using a generator indoors CAN KILL YOU IN MINUTES.**

- Generator exhaust contains carbon monoxide. This is a poison you cannot see or smell.
- NEVER use inside a home or garage, EVEN IF doors and windows are open.
- Only use OUTSIDE and far away from windows, doors, and vents.

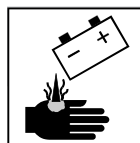

#### **BATTERY ACID can BURN SKIN and EYES.**

- Do not tip battery.
- Replace damaged battery.
- Flush eyes and skin immediately with water.

## 1-4. Compressed Air Hazards



### COMPRESSED AIR EQUIPMENT can injure or kill.

- Incorrect installation or operation of this unit could result in equipment failure and personal injury. Only qualified persons should install, operate, and service this unit according to its Owner's Manual, industry standards, and national, state, and local codes.
- Do not exceed the rated output or capacity of the compressor or any equipment in the compressed air system. Design compressed air system so failure of any component will not put people or property at risk.
- Before working on compressed air system, turn off and lockout/tagout unit, release pressure, and be sure air pressure cannot be accidentally applied.
- Do not work on compressed air system with unit running unless you are a qualified person and following the manufacturer's instructions.
- Do not modify or alter compressor or manufacturer-supplied equipment. Do not disconnect, disable, or override any safety equipment in the compressed air system.
- Use only components and accessories approved by the manufacturer.
- Keep away from potential pinch points or crush points created by equipment connected to the compressed air system.
- Do not work under or around any equipment that is supported only by air pressure. Properly support equipment by mechanical means.



### HOT METAL from air arc cutting and gouging can cause fire or explosion.

- Do not cut or gouge near flammables.
- Watch for fire; keep extinguisher nearby.



### COMPRESSED AIR can injure or kill.

- Before working on compressed air system, turn off and lockout/tagout unit, release pressure, and be sure air pressure cannot be accidentally applied.
- Relieve pressure before disconnecting or connecting air lines.
- Check compressed air system components and all connections and hoses for damage, leaks, and wear before operating unit.
- Do not direct air stream toward self or others.

- Wear protective equipment such as safety glasses, hearing protection, leather gloves, heavy shirt and trousers, high shoes, and a cap when working on compressed air system.
- Use soapy water or an ultrasonic detector to search for leaks—never use bare hands. Do not use equipment if leaks are found.

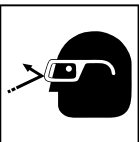

- Reinstall doors, panels, covers, or guards when servicing is finished and before starting unit.
- If ANY air is injected into the skin or body seek medical help immediately.



### BREATHING COMPRESSED AIR can injure or kill.

- Do not use compressed air for breathing.
- Use only for cutting, gouging, and tools.



### TRAPPED AIR PRESSURE AND WHIPPING HOSES can injure.

- Release air pressure from tools and system before servicing, adding or changing attachments, or opening compressor oil drain or oil fill cap.



### MOVING PARTS can injure.

- Keep away from moving parts such as fans, belts and rotors.
- Keep all doors, panels, covers, and guards closed and securely in place.
- Keep hands, hair, loose clothing, and tools away from moving parts.
- Before working on compressed air system, turn off and lockout/tagout unit, release pressure, and be sure air pressure cannot be accidentally applied.
- Have only qualified people remove guards or covers for maintenance and troubleshooting as necessary.
- Reinstall doors, panels, covers, or guards when servicing is finished and before starting engine.



### HOT PARTS can burn.

- Do not touch hot compressor or air system parts.
- Allow cooling period before working on equipment.
- To handle hot parts, use proper tools and/or wear heavy, insulated welding gloves and clothing to

prevent burns.

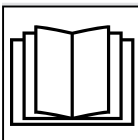

### READ INSTRUCTIONS.

- Read and follow all labels and the Owner's Manual carefully before installing, operating, or servicing unit. Read the safety information at the beginning of the manual and in each section.

- Use only genuine replacement parts from the manufacturer.
- Perform installation, maintenance, and service according to the Owner's Manuals, industry standards, and national, state, and local codes.

## 1-5. Additional Hazards For Installation, Operation, And Maintenance



### FIRE OR EXPLOSION hazard.

- Do not install or place unit on, over, or near combustible surfaces.
- Do not install unit near flammables.
- Do not overload building wiring—be sure power supply system is properly sized, rated, and protected to handle this unit.



### FALLING EQUIPMENT can injure.

- Use lifting eye to lift unit and properly installed accessories only, NOT gas cylinders. Do not exceed maximum lift eye weight rating (see Specifications).
- Use correct procedures and equipment of adequate capacity to lift and support unit.
- If using lift forks to move unit, be sure forks are long enough to extend beyond opposite side of unit.
- Keep equipment (cables and cords) away from moving vehicles when working from an aerial location.

- Follow the guidelines in the Applications Manual for the Revised NIOSH Lifting Equation (Publication No. 94-110) when manually lifting heavy parts or equipment.



### OVERHEATING can damage motors.

- Turn off or unplug equipment before starting or stopping engine.
- Do not let low voltage and frequency caused by low engine speed damage electric motors.
- Use only equipment suitable for operation on 60 or 50/60 Hz power.

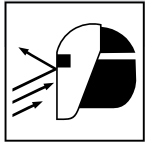

### FLYING SPARKS can injure.

- Wear a face shield to protect eyes and face.
- Shape tungsten electrode only on grinder with proper guards in a safe location wearing proper face, hand, and body protection.
- Sparks can cause fires—keep flammables away.



### MOVING PARTS can injure.

- Keep away from moving parts.
- Keep away from pinch points such as drive rolls.



### BATTERY CHARGING OUTPUT and BATTERY EXPLOSION can injure.

Battery charging not present on all models.

- Always wear a face shield, rubber gloves, and protective clothing when working on a battery.
- Stop engine before disconnecting or connecting battery cables, battery charging cables (if applicable), or servicing battery.
- Do not allow tools to cause sparks when working on a battery.
- Do not use welder to charge batteries or jump start vehicles unless it has a battery charging feature designed for this purpose.
- Observe correct polarity (+ and -) on batteries.
- Disconnect negative (-) cable first and connect it last.
- Keep sparks, flames, cigarettes, and other ignition sources away from batteries. Batteries produce explosive gases during normal operation and when being charged.
- Follow battery manufacturer's instructions when working on or near a battery. See Battery Service Manual (listed in Safety Standards) for additional information.
- Have only qualified persons do battery charging work.
- If battery is being removed from a vehicle for charging, disconnect negative (-) cable first and connect it last. To prevent an arc, make sure all accessories are off.
- Charge lead-acid batteries only. Do not use battery charger to supply power to an extra-low-voltage electrical system or to charge dry cell batteries.
- Do not charge a frozen battery.
- Do not use damaged charging cables.
- Do not charge batteries in a closed area or where ventilation is restricted.
- Do not charge a battery that has loose terminals or one showing damage such as a cracked case or cover.
- Before charging battery, select correct charger voltage to match battery voltage.
- Set battery charging controls to the Off position before connecting to battery. Do not allow battery charging clips to touch each other.
- Keep charging cables away from vehicle hood, door, or moving parts.



### HIGH PRESSURE FLUIDS can injure or kill.

- Engine fuel system components can be under high pressure.
- Before working on fuel system, turn off engine to release pressure.
- If any fluid is injected into the skin or body seek medical help immediately.



### WELDING WIRE can injure.

- Do not press gun trigger until instructed to do so.
- Do not point gun toward any part of the body, other people, or any metal when threading welding wire.

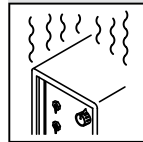

### OVERUSE can cause OVERHEATING.

- Allow cooling period; follow rated duty cycle.
- Reduce current or reduce duty cycle before starting to weld again.
- Do not block or filter airflow to unit.

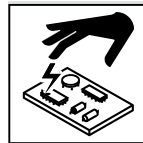

### STATIC (ESD) can damage PC boards.

- Put on grounded wrist strap BEFORE handling boards or parts.
- Use proper static-proof bags and boxes to store, move, or ship PC boards.



### TILTING OF TRAILER can injure.

- Use tongue jack or blocks to support weight.
- Properly install welding generator onto trailer according to instructions supplied with trailer.

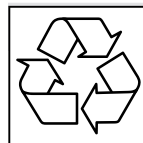

### RECYCLE.

- Recycle or dispose of used liquids in an environmentally safe way. This is especially true for engine fluids such as drain oil and used coolant; this is also important for coolant from torch/gun cooling systems.
- Contact your local recycling office or your local distributor for information about how to dispose of parts and equipment in an environmentally safe way.

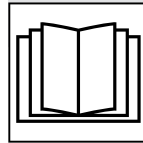

### READ INSTRUCTIONS.

- Read and follow all labels and the Owner's Manual carefully before installing, operating, or servicing unit. Read the safety information at the beginning of the manual and in each section.
- Use only genuine replacement parts from the manufacturer.
- Perform installation, maintenance, and service according to the Owner's Manuals, industry standards, and national, state, and local codes.

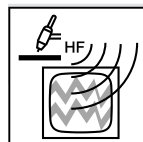

### H.F. RADIATION can cause interference.

- High-frequency (H.F.) can interfere with radio navigation, safety services, computers, and communications equipment.
- Have only qualified persons familiar with electronic equipment perform this installation.
- The user is responsible for having a qualified electrician promptly correct any interference problem resulting from the installation.

- If notified by the FCC about interference, stop using the equipment at once.
- Have the installation regularly checked and maintained.
- Keep high-frequency source doors and panels tightly shut, keep spark gaps at correct setting, and use grounding and shielding to minimize the possibility of interference.



### ARC WELDING can cause interference.

as robots.

- Electromagnetic energy can interfere with sensitive electronic equipment such as microprocessors, computers, and computer-driven equipment such

- Be sure all equipment in the welding area is electromagnetically compatible.
- To reduce possible interference, keep weld cables as short as possible, close together, and down low, such as on the floor.
- Locate welding operation 100 meters from any sensitive electronic equipment.
- Be sure this welding machine is installed and grounded according to this manual.
- If interference still occurs, the user must take extra measures such as moving the welding machine, using shielded cables, using line filters, or shielding the work area.

## 1-6. California Proposition 65 Warnings

**⚠ WARNING – This product can expose you to chemicals including lead, which are known to the state of California to cause cancer and birth defects or other reproductive harm.**

For more information, go to [www.P65Warnings.ca.gov](http://www.P65Warnings.ca.gov).

**For Diesel Engines:**

**⚠ WARNING – Breathing diesel engine exhaust exposes you to chemicals known to the state of California to cause cancer and birth defects or other reproductive harm.**

- Always start and operate the engine in a well-ventilated area.
- If in an enclosed area, vent the exhaust to the outside.
- Do not modify or tamper with the exhaust system.
- Do not idle the engine except as necessary.

For more information, go to [www.P65Warnings.ca.gov/diesel](http://www.P65Warnings.ca.gov/diesel).

## 1-7. Principal Safety Standards

*Safety in Welding, Cutting, and Allied Processes*, American Welding Society standard ANSI Standard Z49.1. Website: [www.aws.org](http://www.aws.org).

*Safe Practices for the Preparation of Containers and Piping for Welding and Cutting*, American Welding Society Standard AWS F4.1. Website: [www.aws.org](http://www.aws.org).

*National Electrical Code*, NFPA Standard 70 from National Fire Protection Association. Website: [www.nfpa.org](http://www.nfpa.org).

*Safe Handling of Compressed Gases in Cylinders*, CGA Pamphlet P-1 from Compressed Gas Association. Website: [www.cganet.com](http://www.cganet.com).

*Safety in Welding, Cutting, and Allied Processes*, CSA Standard W117.2 from Canadian Standards Association. Website: [www.csagroup.org](http://www.csagroup.org).

*Battery Chargers*, CSA Standard C22.2 NO 107.2-01 from Canadian Standards Association. Website: [www.csagroup.org](http://www.csagroup.org).

*Safe Practice For Occupational And Educational Eye And Face Protection*, ANSI Standard Z87.1, from American National Standards Institute. Website: [safetyequipment.org](http://safetyequipment.org).

*Standard for Fire Prevention During Welding, Cutting, and Other Hot Work*, NFPA Standard 51B from National Fire Protection Association. Website: [www.nfpa.org](http://www.nfpa.org).

OSHA, Occupational Safety and Health Standards for General Industry, Title 29, Code of Federal Regulations (CFR), Part 1910.177 Subpart N, Part 1910 Subpart Q, and Part 1926, Subpart J. Website: [www.osha.gov](http://www.osha.gov).

OSHA *Important Note Regarding the ACGIH TLV, Policy Statement on the Uses of TLVs and BEIs*. Website: [www.osha.gov](http://www.osha.gov).

*Portable Generator Hazards Safety Alert* from U.S. Consumer Product Safety Commission (CPSC). Website: [www.cpsc.gov](http://www.cpsc.gov).

*Applications Manual for the Revised NIOSH Lifting Equation* from the National Institute for Occupational Safety and Health (NIOSH). Website: [www.cdc.gov/NIOSH](http://www.cdc.gov/NIOSH).

For Standards regulating hydraulic systems, contact the National Fluid Power Association. Website: [www.nfpa.com](http://www.nfpa.com).

*Battery Service Manual* from the Battery Council International. Website: [www.batterycouncil.org](http://www.batterycouncil.org).

ROM 2024-01

## 1-8. EMF Information

Electric current flowing through any conductor causes localized electric and magnetic fields (EMF). The current from arc welding (and allied processes including spot welding, gouging, plasma arc cutting, and induction heating operations) creates an EMF field around the welding circuit. EMF fields can interfere with some medical implants, e.g. pacemakers. Protective measures for persons wearing medical implants have to be taken. For example, restrict access for passers-by or conduct individual risk assessment for welders. All welders should use the following procedures in order to minimize exposure to EMF fields from the welding circuit:

1. Keep cables close together by twisting or taping them, or using a cable cover.
2. Do not place your body between welding cables. Arrange cables to one side and away from the operator.
3. Do not coil or drape cables around your body.

4. Keep head and trunk as far away from the equipment in the welding circuit as possible.
5. Connect work clamp to workpiece as close to the weld as possible.
6. Do not work next to, sit or lean on the welding power source.
7. Do not weld whilst carrying the welding power source or wire feeder.

### About Implanted Medical Devices:

Implanted Medical Device wearers should consult their doctor and the device manufacturer before performing or going near arc welding, spot welding, gouging, plasma arc cutting, or induction heating operations. If cleared by your doctor, then following the above procedures is recommended.

# SECTION 2 – CONSIGNES DE SÉCURITÉ - LIRE AVANT UTILISATION

**⚠** Pour écarter les risques de blessure pour vous-même et pour autrui — lire, appliquer et ranger en lieu sûr ces consignes relatives aux précautions de sécurité et au mode opératoire.

## 2-1. Symboles utilisés

**⚠** **DANGER!** – Indique une situation dangereuse qui si on l'évite pas peut donner la mort ou des blessures graves. Les dangers possibles sont montrés par les symboles joints ou sont expliqués dans le texte.

**⚠** Indique une situation dangereuse qui si on l'évite pas peut donner la mort ou des blessures graves. Les dangers possibles sont montrés par les symboles joints ou sont expliqués dans le texte.

**AVIS** – Indique des déclarations pas en relation avec des blessures personnelles.

**👉** Indique des instructions spécifiques.



Ce groupe de symboles veut dire Avertissement! Attention! DANGER DE CHOC ELECTRIQUE, PIECES EN MOUVEMENT, et PIECES CHAUDES. Reportez-vous aux symboles et aux directives ci-dessous afin de connaître les mesures à prendre pour éviter tout danger.

## 2-2. Dangers relatifs au soudage à l'arc

**⚠** Les symboles représentés ci-dessous sont utilisés dans ce manuel pour attirer l'attention et identifier les dangers possibles. En présence de ce symbole, prendre garde et suivre les instructions afférentes pour éviter tout risque. Les consignes de sécurité présentées ci-après ne font que résumer l'information contenue dans les Normes de sécurité principales. Lire et suivre toutes les Normes de sécurité.

**⚠** L'installation, l'utilisation, l'entretien et les réparations ne doivent être confiés qu'à des personnes qualifiées. Une personne qualifiée est définie comme celle qui, par la possession d'un diplôme reconnu, d'un certificat ou d'un statut professionnel, ou qui, par une connaissance, une formation et une expérience approfondies, a démontré avec succès sa capacité à résoudre les problèmes liés à la tâche, le travail ou le projet et a reçu une formation en sécurité afin de reconnaître et d'éviter les risques inhérents.

**⚠** Au cours de l'utilisation, tenir toute personne à l'écart et plus particulièrement les enfants.



### UN CHOC ÉLECTRIQUE peut tuer.

Un simple contact avec des pièces électriques peut provoquer une électrocution ou des blessures graves. L'électrode et le circuit de soudage sont sous tension dès que l'appareil est sur ON. Le circuit d'entrée et les circuits internes de l'appareil sont également sous tension à ce moment-là. En soudage semi-automatique ou automatique, le fil, le dévidoir, le logement des galets d'entraînement et les pièces métalliques en contact avec le fil de soudage sont sous tension. Des matériels mal installés ou mal mis à la terre présentent un danger.

- Ne jamais toucher les pièces électriques sous tension.
- Porter des gants et des vêtements de protection secs ne comportant pas de trous.
- S'isoler de la pièce et de la terre au moyen de tapis ou d'autres moyens isolants suffisamment grands pour empêcher le contact physique éventuel avec la pièce ou la terre.
- Ne pas utiliser de sortie de soudage CA dans des zones humides ou confinées ou s'il y a un risque de chute.
- Ne stockez pas et n'utilisez pas l'équipement dans de l'eau stagnante.
- Se servir d'une source électrique à courant électrique UNIQUEMENT si le procédé de soudage le demande.
- Si l'utilisation d'une source électrique à courant électrique s'avère nécessaire, se servir de la fonction de télécommande si l'appareil en est équipé.
- Des précautions de sécurité supplémentaires sont requises dans des environnements à risque comme: les endroits humides ou lorsque l'on porte des vêtements mouillés; sur des structures

métalliques au sol, grillages et échafaudages; dans des positions assises, à genoux et allongées; ou quand il y a un risque important de contact accidentel avec la pièce ou le sol. Dans ces cas utiliser les appareils suivants dans l'ordre de préférence: 1) un poste à souder DC semi-automatique de type CV (MIG/MAG), 2) un poste à souder manuel (électrode enrobée) DC, 3) un poste à souder manuel AC avec tension à vide réduite. Dans la plupart des cas, un poste courant continu de type CV est recommandé. Et, ne pas travailler seul!

- Ne brancher aucun système de distribution électrique normalement fourni par un réseau public à moins qu'un commutateur de transfert et une procédure de mise à la terre adéquats ne soient mis en place.
- Couper l'alimentation ou arrêter le moteur avant de procéder à l'installation, à la réparation ou à l'entretien de l'appareil. Déverrouiller l'alimentation selon la norme OSHA 29 CFR 1910.147 (voir normes de sécurité).
- Installer et mettre à la terre correctement cet appareil conformément à son manuel d'utilisation et aux codes nationaux, provinciaux et municipaux.
- Toujours vérifier la terre du cordon d'alimentation - Vérifier et s'assurer que le fil de terre du cordon d'alimentation est bien raccordé à la borne de terre du sectionneur ou que la fiche du cordon est raccordée à une prise correctement mise à la terre.
- En effectuant les raccordements d'entrée fixer d'abord le conducteur de mise à la terre approprié et contre-vérifier les connexions.
- Les câbles doivent être exempts d'humidité, d'huile et de graisse; protégez-les contre les étincelles et les pièces métalliques chaudes.
- Vérifier fréquemment le cordon d'alimentation et le conducteur de mise à la terre afin de s'assurer qu'il n'est pas altéré ou dénudé -, le remplacer immédiatement s'il l'est -. Un fil dénudé peut entraîner la mort.
- Mettre l'appareil hors tension quand on ne l'utilise pas.
- Ne pas utiliser des câbles usés, endommagés, sous dimensionnés ou réparés.
- Ne pas enrouler les câbles autour du corps.
- Si la pièce soudée doit être mise à la terre, le faire directement avec un câble distinct - ne pas utiliser le connecteur de pièce ou le câble de retour.
- Ne pas toucher l'électrode quand on est en contact avec la pièce, la terre ou une électrode provenant d'une autre machine.
- Ne pas toucher des porte électrodes connectés à deux machines en même temps à cause de la présence d'une tension à vide doublée.

- N'utiliser qu'un matériel en bon état. Réparer ou remplacer sur-le-champ les pièces endommagées. Entretien l'appareil conformément à ce manuel.
- Ne pas toucher aux portes-électrodes qui sont raccordés à deux machines à souder en même temps, car cela entraîne la présence d'une tension de circuit-ouvert double.
- Porter un harnais de sécurité quand on travaille en hauteur.
- Maintenir solidement en place tous les panneaux et capots.
- Fixer le câble de retour de façon à obtenir un bon contact métal-métal avec la pièce à souder ou la table de travail, le plus près possible de la soudure.
- Isoler la pince de masse quand pas mis à la pièce pour éviter le contact avec tout objet métallique.
- Ne pas raccorder plus d'une électrode ou plus d'un câble de masse à une même borne de sortie de soudage. Débrancher le câble pour le procédé non utilisé.
- Utiliser une protection GFCI lors de l'utilisation d'appareils auxiliaires. Testez les prises GFCI à haute vitesse.



### LES PIÈCES CHAUDES peuvent provoquer des brûlures.

- Ne pas toucher des parties chaudes à mains nues.
- Prévoir une période de refroidissement avant de travailler à l'équipement.
- Ne pas toucher aux pièces chaudes, utiliser les outils recommandés et porter des gants de soudage et des vêtements épais pour éviter les brûlures.

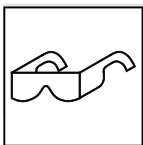

### DES PIÈCES DE METAL ou DES SALETES peuvent provoquer des blessures dans les yeux.

- Le soudage, l'écaillage, le passage de la pièce à la brosse en fil de fer, et le meulage génèrent des étincelles et des particules métalliques volantes. Pendant la période de refroidissement des soudures, elles risquent de projeter du laitier.
- Porter des lunettes de sécurité avec écrans latéraux ou un écran facial.



### LES FUMÉES ET LES GAZ peuvent être dangereux.

Le soudage génère des fumées et des gaz. Leur inhalation peut être dangereux pour votre santé.

- Eloigner votre tête des fumées. Ne pas respirer les fumées.
- À l'intérieur, ventiler la zone et/ou utiliser une ventilation forcée au niveau de l'arc pour l'évacuation des fumées et des gaz de soudage. Pour déterminer la bonne ventilation, il est recommandé de procéder à un prélèvement pour la composition et la quantité de fumées et de gaz auxquelles est exposé le personnel.
- Si la ventilation est médiocre, porter un respirateur anti-vapeurs approuvé.
- Lire et comprendre les fiches de données de sécurité et les instructions du fabricant concernant les adhésifs, les revêtements, les nettoyants, les consommables, les produits de refroidissement, les dégraissants, les flux et les métaux.
- Travailler dans un espace fermé seulement s'il est bien ventilé ou en portant un respirateur à alimentation d'air. Demander toujours à un surveillant dûment formé de se tenir à proximité. Des fumées et des gaz de soudage peuvent déplacer l'air et abaisser le niveau d'oxygène provoquant des blessures ou des accidents mortels. S'assurer que l'air de respiration ne présente aucun danger.
- Ne pas souder dans des endroits situés à proximité d'opérations de dégraissage, de nettoyage ou de pulvérisation. La chaleur et les rayons de l'arc peuvent réagir en présence de vapeurs et former des gaz hautement toxiques et irritants.

- Ne pas souder des métaux munis d'un revêtement, tels que l'acier galvanisé, plaqué en plomb ou au cadmium à moins que le revêtement n'ait été enlevé dans la zone de soudure, que l'endroit soit bien ventilé, et en portant un respirateur à alimentation d'air. Les revêtements et tous les métaux renfermant ces éléments peuvent dégager des fumées toxiques en cas de soudage.



### LES ACCUMULATIONS DE GAZ risquent de provoquer des blessures ou même la mort.

- Fermer l'alimentation du gaz comprimé en cas de non utilisation.
- Veiller toujours à bien aérer les espaces confinés ou se servir d'un respirateur d'adduction d'air homologué.



### LES RAYONS DE L'ARC peuvent provoquer des brûlures dans les yeux et sur la peau.

Le rayonnement de l'arc du procédé de soudage génère des rayons visibles et invisibles intenses (ultraviolets et infrarouges) susceptibles de provoquer des brûlures dans les yeux et sur la peau. Des étincelles sont projetées pendant le soudage.

- Porter un casque de soudage approuvé muni de verres filtrants approprié pour protéger visage et yeux pendant le soudage (voir ANSI Z49.1 et Z87.1 énuméré dans les normes de sécurité).
- Porter des lunettes de sécurité avec écrans latéraux même sous votre casque.
- Avoir recours à des écrans protecteurs ou à des rideaux pour protéger les autres contre les rayonnements les éblouissements et les étincelles ; prévenir toute personne sur les lieux de ne pas regarder l'arc.
- Porter une protection corporelle en cuir ou des vêtements ignifuges (FRC). La protection du corps comporte des vêtements sans huile, comme des gants de cuir, une chemise solide, des pantalons sans revers, des chaussures hautes et une casquette.



### LE SOUDAGE peut provoquer un incendie ou une explosion.

Le soudage effectué sur des conteneurs fermés tels que des réservoirs, tambours ou des conduites peut provoquer leur éclatement. Des étincelles peuvent être projetées de l'arc de soudure. La projection d'étincelles, des pièces chaudes et des équipements chauds peut provoquer des incendies et des brûlures. Le contact accidentel de l'électrode avec des objets métalliques peut provoquer des étincelles, une explosion, un surchauffement ou un incendie. Avant de commencer le soudage, vérifier et s'assurer que l'endroit ne présente pas de danger.

- Déplacer toutes les substances inflammables à une distance de 10,7 m de l'arc de soudage. En cas d'impossibilité les recouvrir soigneusement avec des protections homologués.
- Ne pas souder dans un endroit où des étincelles peuvent tomber sur des substances inflammables.
- Se protéger et d'autres personnes de la projection d'étincelles et de métal chaud.
- Des étincelles et des matériaux chauds du soudage peuvent facilement passer dans d'autres zones en traversant de petites fissures et des ouvertures.
- Surveiller tout déclenchement d'incendie et tenir un extincteur à proximité.
- Le soudage effectué sur un plafond, plancher, paroi ou séparation peut déclencher un incendie de l'autre côté.
- Ne pas couper ou souder des jantes ou des roues. Les pneus peuvent exploser s'ils sont chauffés. Les jantes et les roues réparées peuvent défaillir. Voir OSHA 29 CFR 1910.177 énuméré dans les normes de sécurité.

- Ne pas effectuer le soudage sur des conteneurs fermés tels que des réservoirs, tambours, ou conduites, à moins qu'ils n'aient été préparés correctement conformément à AWS F4.1 (voir les Normes de Sécurité).
- Ne pas souder là où l'air ambiant pourrait contenir des poussières, gaz ou émanations inflammables (vapeur d'essence, par exemple).
- Brancher le câble de masse sur la pièce la plus près possible de la zone de soudage pour éviter le transport du courant sur une longue distance par des chemins inconnus éventuels en provoquant des risques d'électrocution, d'étincelles et d'incendie.
- Ne pas utiliser le poste de soudage pour dégeler des conduites gelées.
- En cas de non utilisation, enlever la baguette d'électrode du porte-électrode ou couper le fil à la pointe de contact.
- Porter une protection corporelle en cuir ou des vêtements ignifuges (FRC). La protection du corps comporte des vêtements sans huile, comme des gants de cuir, une chemise solide, des pantalons sans revers, des chaussures hautes et une casquette.
- Avant de souder, retirer toute substance combustible de vos poches telles qu'un allumeur au butane ou des allumettes.
- Une fois le travail achevé, assurez-vous qu'il ne reste aucune trace d'étincelles incandescentes ni de flammes.
- Utiliser exclusivement des fusibles ou coupe-circuits appropriés. Ne pas augmenter leur puissance; ne pas les ponter.
- Suivre les recommandations dans OSHA 1910.252 (a) (2) (iv) et NFPA 51B pour les travaux à chaud et avoir de la surveillance et un extincteur à proximité.
- Lire et comprendre les fiches de données de sécurité et les instructions du fabricant concernant les adhésifs, les revêtements, les nettoyants, les consommables, les produits de refroidissement, les dégraissateurs, les flux et les métaux.



### Le BRUIT peut endommager l'ouïe.

Le bruit des processus et des équipements peut affecter l'ouïe.

- Porter des protections approuvées pour les oreilles si le niveau sonore est trop élevé.



### Les CHAMPS ÉLECTROMAGNÉTIQUES (CEM) peuvent affecter les implants médicaux.

- Les porteurs de stimulateurs cardiaques et autres implants médicaux doivent rester à distance.

## 2-3. Dangers existant en relation avec le moteur



### L'EXPLOSION DE LA BATTERIE peut provoquer des blessures.

- Toujours porter une protection faciale, des gants en caoutchouc et vêtements de protection lors d'une intervention sur la batterie.
- Arrêter le moteur avant de débrancher ou de brancher des câbles de batterie, des câbles de chargeur de batterie (le cas échéant) ou de batterie d'entretien.
- Éviter de provoquer des étincelles avec les outils en travaillant sur la batterie.
- Ne pas utiliser l'appareil de soudage pour charger des batteries ou faire démarrer des véhicules à l'aide de câbles de démarrage, sauf si l'appareil dispose d'une fonctionnalité de charge de batterie destinée à cet usage.
- Observer la polarité correcte (+ et -) sur les batteries.
- Débrancher le câble négatif (-) en premier lieu. Le rebrancher en dernier lieu.

- Les porteurs d'implants médicaux doivent consulter leur médecin et le fabricant du dispositif avant de s'approcher de la zone où se déroule le soudage à l'arc, du soudage par points, du gougeage, de la découpe plasma ou une opération de chauffage par induction.

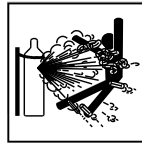

### Si des BOUTEILLES sont endommagées, elles pourront exploser.

Des bouteilles de gaz comprimé protecteur contiennent du gaz sous haute pression. Si une bouteille est endommagée, elle peut exploser. Du fait que les bouteilles de gaz font normalement partie du procédé de soudage, les manipuler avec précaution.

- Protéger les bouteilles de gaz comprimé d'une chaleur excessive, des chocs mécaniques, des dommages physiques, du laitier, des flammes ouvertes, des étincelles et des arcs.
- Placer les bouteilles debout en les fixant dans un support stationnaire ou dans un porte-bouteilles pour les empêcher de tomber ou de se renverser.
- Tenir les bouteilles éloignées des circuits de soudage ou autres circuits électriques.
- Ne jamais placer une torche de soudage sur une bouteille à gaz.
- Une électrode de soudage ne doit jamais entrer en contact avec une bouteille.
- Ne jamais souder une bouteille pressurisée - risque d'explosion.
- Utiliser seulement des bouteilles de gaz comprimé, régulateurs, tuyaux et raccords convenables pour cette application spécifique; les maintenir ainsi que les éléments associés en bon état.
- Tourner le dos à la sortie de vanne lors de l'ouverture de la vanne de la bouteille. Ne pas se tenir devant ou derrière le régulateur lors de l'ouverture de la vanne.
- Maintenir le chapeau de protection sur la soupape, sauf en cas d'utilisation ou de branchement de la bouteille.
- Utilisez les équipements corrects, les bonnes procédures et suffisamment de personnes pour soulever, déplacer et transporter les bouteilles.
- Lire et suivre les instructions sur les bouteilles de gaz comprimé, l'équipement connexe et le dépliant P-1 de la CGA (Compressed Gas Association) mentionné dans les principales normes de sécurité.



### LE CARBURANT MOTEUR peut provoquer un incendie ou une explosion. LA CHALEUR DU MOTEUR peut provoquer un incendie.

- Arrêter le moteur avant de vérifier le niveau de carburant ou de faire le plein.
- Ne pas faire le plein en fumant ou proche d'une source d'étincelles ou d'une flamme nue.

- Ne pas faire le plein de carburant à ras bord; prévoir de l'espace pour son expansion.
- Faire attention de ne pas renverser de carburant. Nettoyer tout carburant renversé avant de faire démarrer le moteur.
- Jeter les chiffons dans un récipient ignifuge.
- Toujours garder le pistolet en contact avec le réservoir lors du remplissage.
- Ne pas placer l'appareil sur, au-dessus ou à proximité de surfaces inflammables.
- Tenir à distance les produits inflammables de l'échappement.



### Les PIÈCES MOBILES peuvent causer des blessures.

- S'abstenir de toucher des parties mobiles telles que des ventilateurs, courroies et rotors.
- Maintenir fermés et verrouillés les portes, panneaux, recouvrements et dispositifs de protection.
- Arrêter le moteur avant d'installer ou brancher l'appareil.
- Lorsque cela est nécessaire pour des travaux d'entretien et de dépannage, faire retirer les portes, panneaux, recouvrements ou dispositifs de protection uniquement par du personnel qualifié.
- Pour empêcher tout démarrage accidentel pendant les travaux d'entretien, débrancher le câble négatif (-) de batterie delaborne.
- Ne pas approcher les mains, cheveux, vêtements lâches et outils des organes mobiles.
- Remettre en place les portes, panneaux, recouvrements ou dispositifs de protection à la fin des travaux d'entretien et avant de mettre le moteur en marche.
- Avant d'intervenir, déposer les bougies ou injecteurs pour éviter la mise en route accidentelle du moteur.
- Bloquer le volant moteur pour éviter sa rotation lors d'une intervention sur le générateur.



### LES ÉTINCELLES À L'ÉCHAPPEMENT peuvent provoquer un incendie.

- Empêcher les étincelles d'échappement du moteur de provoquer un incendie.
- Utiliser uniquement un pare-étincelles approuvé - voir codes en vigueur.



### LES PIÈCES CHAUDES peuvent provoquer des brûlures.

- Ne pas toucher des parties chaudes à mains nues.

- Prévoir une période de refroidissement avant de travailler à l'équipement.
- Ne pas toucher aux pièces chaudes, utiliser les outils recommandés et porter des gants de soudage et des vêtements épais pour éviter les brûlures.

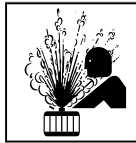

### LA VAPEUR ET LE LIQUIDE DE REFROIDISSEMENT CHAUD peuvent provoquer des brûlures.

- Il est préférable de vérifier le liquide de refroidissement une fois le moteur refroidi pour éviter de se brûler.
- Toujours vérifier le niveau de liquide de refroidissement dans le vase d'expansion (si présent), et non dans le radiateur (sauf si précisé autrement dans la section maintenance du manuel du moteur).
- Si le moteur est chaud et que le liquide doit être vérifié, opérer comme suivant.
- Mettre des lunettes de sécurité et des gants, placer un torchon sur le bouchon du radiateur.
- Dévisser le bouchon légèrement et laisser la vapeur s'échapper avant d'enlever le bouchon.

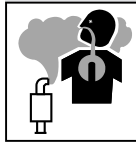

### L'utilisation d'un groupe autonome à l'intérieur PEUT VOUS TUER EN QUELQUES MINUTES.

- Les fumées d'un groupe autonome contiennent du monoxyde de carbone. C'est un poison invisible et inodore.
- JAMAIS utiliser dans une maison ou garage, même avec les portes et fenêtres ouvertes.
- Uniquement utiliser à l'EXTERIEUR, loin des portes, fenêtres et bouches aération.

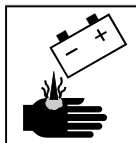

### L'ACIDE DE LA BATTERIE peut provoquer des brûlures dans les YEUX ET SUR LA PEAU.

- Ne pas renverser la batterie.
- Remplacer une batterie endommagée.
- Rincer immédiatement les yeux et la peau à l'eau.

## 2-4. Dangers liés à l'air comprimé



### Un ÉQUIPEMENT PNEUMATIQUE risque de provoquer des blessures ou même la mort.

- Une installation ou une utilisation incorrecte de cet appareil pourrait conduire à des dégâts matériels ou corporels. Seul un personnel qualifié est autorisé à installer, utiliser et entretenir cet appareil conformément à son manuel d'utilisation, aux normes industrielles et aux codes nationaux, d'état ou locaux.
- Ne pas dépasser le débit nominal ou la capacité du compresseur ou de tout équipement du circuit d'air comprimé. Concevoir le circuit d'air comprimé de telle sorte que la défaillance d'un composant ne risque pas de provoquer un accident matériel ou corporel.
- Avant d'intervenir sur le circuit d'air comprimé, couper l'alimentation électrique, verrouiller et étiqueter l'appareil, détendre la pression et s'assurer que le circuit d'air ne peut être mis sous pression par inadvertance.

- Ne pas intervenir sur le circuit d'air comprimé lorsque l'appareil fonctionne. Seul un personnel qualifié est autorisé, et appliquant les consignes du fabricant.
- Ne pas modifier ou altérer le compresseur ou les équipements fournis par le fabricant. Ne pas débrancher, désactiver ou neutraliser les équipements de sécurité du circuit d'air comprimé.
- Utiliser uniquement des composants et accessoires homologués par le fabricant.
- Se tenir à l'écart de tout point présentant un danger de pincement ou d'écrasement créé par l'équipement raccordé au circuit d'air comprimé.
- Ne pas intervenir sous ou autour d'un équipement qui n'est soutenu que par la pression pneumatique. Soutenir l'équipement de façon appropriée par un moyen mécanique.



**MÉTAL CHAUD** provenant du découpage ou du gougeage à l'arc risque de provoquer un incendie ou une explosion.

- Ne pas découper ou gouger à proximité de produits inflammables.
- Attention aux risques d'incendie: tenir un extincteur à proximité.



**L'AIR COMPRIMÉ** risque de provoquer des blessures ou même la mort.

- Avant d'intervenir sur le circuit d'air comprimé, couper l'alimentation électrique, verrouiller et étiqueter l'appareil, détendre la pression et s'assurer que le circuit d'air ne peut être mis sous pression par inadvertance.
- Détendre la pression avant de débrancher ou de brancher des canalisations d'air.
- Avant d'utiliser l'appareil, contrôler les composants du circuit d'air comprimé, les branchements et les flexibles en recherchant tout signe de détérioration, de fuite et d'usure.
- Ne pas diriger un jet d'air vers soi-même ou vers autrui.
- Pour intervenir sur un circuit d'air comprimé, porter un équipement de protection tel que des lunettes de sécurité, des gants de cuir, une chemise et un pantalon en tissu résistant, des chaussures montantes et une coiffe.
- Pour rechercher des fuites, utiliser de l'eau savonneuse ou un détecteur à ultrasons, jamais les mains nues. En cas de détection de fuite, ne pas utiliser l'équipement.
- Remettre les portes, panneaux, recouvrements ou dispositifs de protection quand l'entretien est terminé et avant de mettre en marche l'appareil.
- En cas d'injection d'air dans la peau ou le corps, demander immédiatement une assistance médicale.

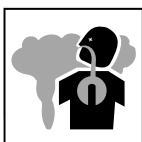

**L'INHALATION D'AIR COMPRIMÉ** risque de provoquer des blessures ou même la mort.

- Ne pas inhaler d'air comprimé.
- Utiliser l'air comprimé uniquement pour découper ou gouger ainsi que pour l'outillage pneumatique.



Une **PRESSION D'AIR RÉSIDUELLE** ET DES FLEXIBLES QUI FOUETTENT risquent de provoquer des blessures.

- Détendre la pression pneumatique des outils et circuits avant d'entretenir, ajouter ou changer des accessoires et avant d'ouvrir le bouchon de vidange ou de remplissage d'huile du compresseur.



Les **PIÈCES MOBILES** peuvent causer des blessures.

- S'abstenir de toucher des parties mobiles telles que des ventilateurs, courroies et rotors.
- Maintenir fermés et verrouillés les portes, panneaux, recouvrements et dispositifs de protection.
- Ne pas approcher les mains, cheveux, vêtements lâches et outils des organes mobiles.
- Avant d'intervenir sur le circuit d'air comprimé, couper l'alimentation électrique, verrouiller et étiqueter l'appareil, détendre la pression et s'assurer que le circuit d'air ne peut être mis sous pression par inadvertance.
- Demander seulement à un personnel qualifié d'enlever les dispositifs de sécurité ou les recouvrements pour effectuer, s'il y a lieu, des travaux d'entretien et de dépannage.
- Remettre en place les portes, panneaux, recouvrements ou dispositifs de protection à la fin des travaux d'entretien et avant de mettre le moteur en marche.



**DES PIÈCES CHAUDES** peuvent provoquer des brûlures graves.

- Ne pas toucher de pièces chaudes du compresseur ou du circuit d'air.
- Prévoir une période de refroidissement avant d'intervenir sur l'équipement.
- Ne pas toucher aux pièces chaudes, utiliser les outils recommandés et porter des gants de soudage et des vêtements épais pour éviter les brûlures.

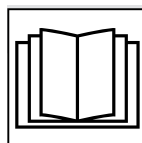

**LIRE LES INSTRUCTIONS.**

- Lire et appliquer les instructions sur les étiquettes et le Mode d'emploi avant l'installation, l'utilisation ou l'entretien de l'appareil. Lire les informations de sécurité au début du manuel et dans chaque section.
- N'utiliser que des pièces de remplacement provenant du fabricant.
- Effectuer l'installation, l'entretien et toute intervention selon les manuels d'utilisateurs, les normes nationales, provinciales et de l'industrie, ainsi que les codes municipaux.

## 2-5. Symboles de dangers supplémentaires en relation avec l'installation, le fonctionnement et la maintenance



**Risque D'INCENDIE OU D'EXPLOSION.**

- Ne pas placer l'appareil sur, au-dessus ou à proximité de surfaces inflammables.
- Ne pas installer l'appareil à proximité de produits inflammables
- Ne pas surcharger l'installation électrique – s'assurer que l'alimentation est correctement dimensionnée et protégée avant de mettre l'appareil en service.



**LA CHUTE DE L'ÉQUIPEMENT** peut provoquer des blessures.

- Utiliser seulement l'anneau de levage pour soulever l'appareil et des accessoires correctement installés, non pas les bouteilles de gaz. Ne pas dépasser les capacités maximales de l'anneau de levage (voir Spécifications).
- Utilisez les procédures correctes et des équipements d'une capacité appropriée pour soulever et supporter l'appareil.
- En utilisant des fourches de levage pour déplacer l'unité, s'assurer que les fourches sont suffisamment longues pour dépasser du côté opposé de l'appareil.
- Tenir l'équipement (câbles et cordons) à distance des véhicules mobiles lors de toute opération en hauteur.

- Suivre les consignes du Manuel des applications pour l'équation de levage NIOSH révisée (Publication N° 94-110) lors du levage manuel de pièces ou équipements lourds.



### LE SURCHAUFFEMENT peut endommager le moteur électrique.

- Arrêter ou déconnecter l'équipement avant de démarrer ou d'arrêter le moteur.
- Ne pas laisser tourner le moteur trop lentement sous risque d'endommager le moteur électrique à cause d'une tension et d'une fréquence trop faibles.
- Utiliser uniquement des équipements adéquats pour un fonctionnement avec une alimentation de 50/60 ou de 60 Hz.



### LES ÉTINCELLES PROJÉTÉES peuvent provoquer des blessures.

- Porter un écran facial pour protéger le visage et les yeux.
- Affûter l'électrode au tungstène uniquement à la meuleuse dotée de protecteurs. Cette manœuvre est à exécuter dans un endroit sûr lorsque l'on porte l'équipement homologué de protection du visage, des mains et du corps.
- Les étincelles risquent de causer un incendie - éloigner toute substance inflammable.



### Les PIÈCES MOBILES peuvent causer des blessures.

- Ne pas s'approcher des organes mobiles.
- Ne pas s'approcher des points de coincement tels que des rouleaux de commande.



### LA SORTIE DE RECHARGE et L'EXPLOSION DE LA BATTERIE peuvent provoquer des blessures.

La recharge de batterie n'existe pas sur tous les modèles.

- Toujours porter une protection faciale, des gants en caoutchouc et vêtements de protection lors d'une intervention sur la batterie.
- Arrêter le moteur avant de débrancher ou de brancher des câbles de batterie, des câbles de chargeur de batterie (le cas échéant) ou de batterie d'entretien.
- Éviter de provoquer des étincelles avec les outils en travaillant sur la batterie.
- Ne pas utiliser l'appareil de soudage pour charger des batteries ou faire démarrer des véhicules à l'aide de câbles de démarrage, sauf si l'appareil dispose d'une fonctionnalité de charge de batterie destinée à cet usage.
- Observer la polarité correcte (+ et -) sur les batteries.
- Débrancher le câble négatif (-) en premier lieu. Le rebrancher en dernier lieu.
- Les sources d'étincelles, flammes nues, cigarettes et autres sources d'inflammation doivent être maintenues à l'écart des batteries. Ces dernières produisent des gaz explosifs en fonctionnement normal et en cours de charge.
- Suivre les instructions du fabricant de la batterie lors d'opérations sur une batterie ou à proximité de celle-ci. Voir le manuel de service de batterie (indiqué dans Normes de sécurité) pour plus d'informations.
- Les opérations de charge de batterie ne doivent être effectuées que par des personnes qualifiées.
- Pour enlever la batterie d'un véhicule pour la recharge, débrancher tout d'abord le câble négatif (-) et le rebrancher en dernier lieu. Pour éviter un arc, s'assurer que tous les accessoires sont débranchés.

- Ne charger que des batteries plomb-acide. Ne pas utiliser le chargeur de batterie pour alimenter un autre circuit électrique basse tension ou pour charger des batteries sèches.
- Ne pas charger une batterie gelée.
- Ne pas utiliser de câbles de charge endommagés.
- Ne pas charger des batteries dans un espace fermé ou en l'absence d'une ventilation.
- Ne pas charger une batterie dont les bornes sont desserrées ou présentant une détérioration comme par exemple un boîtier ou un couvercle fissuré.
- Avant de charger une batterie, sélectionner la tension de charge correspondant à la tension de la batterie.
- Régler les commandes de charge de batterie sur la position d'arrêt avant de brancher la batterie. Veiller à ce que les pinces de charge ne se touchent pas.
- Ranger les câbles de charge à distance du capot, des portes et des pièces mobiles du véhicule.



### LES LIQUIDES PRESSURISÉS peuvent blesser ou tuer.

- Les composants du système d'alimentation peuvent contenir du carburant sous pression élevée.
- Avant d'intervenir sur le système d'alimentation de carburant, arrêter le moteur pour dépressuriser le système.
- En cas d'injection de tout liquide sous la peau ou dans le corps, solliciter une aide médicale sur le champ.



### LES FILS DE SOUDAGE peuvent provoquer des blessures.

- Ne pas appuyer sur la gachette avant d'en avoir reçu l'instruction.
- Ne pas diriger le pistolet vers soi, d'autres personnes ou toute pièce mécanique en engageant le fil de soudage.

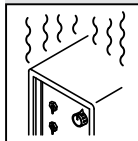

### L'EMPLOI EXCESSIF peut SURCHAUFFER L'ÉQUIPEMENT.

- Laisser l'équipement refroidir ; respecter le facteur de marche nominal.
- Réduire le courant ou le cycle opératoire avant de recommencer le soudage.
- Ne pas obstruer les passages d'air du poste.

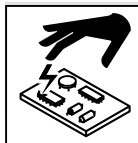

### LES CHARGES ÉLECTROSTATIQUES peuvent endommager les circuits imprimés.

- Établir la connexion avec la barrette de terre AVANT de manipuler des cartes ou des pièces.
- Utiliser des pochettes et des boîtes antistatiques pour stocker, déplacer ou expédier des cartes de circuits imprimés.



### UNE REMORQUE QUI BASCULE peut provoquer des blessures.

- Utiliser les supports de la remorque ou des blocs pour soutenir le poids.
- Installer convenablement le poste sur la remorque comme indiqué dans le manuel s'y rapportant.

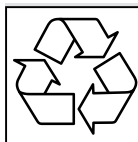

### RECYCLER.

- Recycler ou éliminer les liquides usagés d'une manière respectueuse de l'environnement. Cela est particulièrement vrai pour les fluides du moteur tels que l'huile de vidange et le liquide de refroidissement usagés ; ceci est également important pour le liquide de refroidissement provenant des systèmes de refroidissement de la torche/du pistolet.

- Contactez votre bureau de recyclage local ou votre distributeur local pour obtenir des informations sur la manière de mettre au rebut les pièces et l'équipement d'une manière respectueuse de l'environnement.

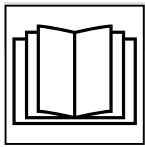

### LIRE LES INSTRUCTIONS.

- Lire et appliquer les instructions sur les étiquettes et le Mode d'emploi avant l'installation, l'utilisation ou l'entretien de l'appareil. Lire les informations de sécurité au début du manuel et dans chaque section.

- N'utiliser que des pièces de remplacement provenant du fabricant.
- Effectuer l'installation, l'entretien et toute intervention selon les manuels d'utilisateurs, les normes nationales, provinciales et de l'industrie, ainsi que les codes municipaux.

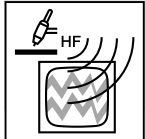

### LE RAYONNEMENT HAUTE FRÉQUENCE (H.F.) risque de provoquer des interférences.

- Le rayonnement haute fréquence (H.F.) peut provoquer des interférences avec les équipements de radio-navigation et de communication, les services de sécurité et les ordinateurs.
- Demander seulement à des personnes qualifiées familiarisées avec des équipements électroniques de faire fonctionner l'installation.
- L'utilisateur est tenu de faire corriger rapidement par un électricien qualifié les interférences résultant de l'installation.

- Si le FCC signale des interférences, arrêter immédiatement l'appareil.
- Effectuer régulièrement le contrôle et l'entretien de l'installation.
- Maintenir soigneusement fermés les portes et les panneaux des sources de haute fréquence, maintenir les éclateurs à une distance correcte et utiliser une terre et un blindage pour réduire les interférences éventuelles.

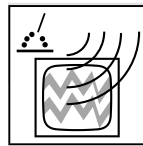

### LE SOUDAGE À L'ARC risque de provoquer des interférences.

- L'énergie électromagnétique risque de provoquer des interférences pour l'équipement électronique sensible tel que les ordinateurs et l'équipement commandé par ordinateur tel que les robots.
- Veiller à ce que tout l'équipement de la zone de soudage soit compatible électromagnétiquement.
- Pour réduire la possibilité d'interférence, maintenir les câbles de soudage aussi courts que possible, les grouper, et les poser aussi bas que possible (ex. par terre).
- Veiller à souder à une distance de 100 mètres de tout équipement électronique sensible.
- Veiller à ce que ce poste de soudage soit posé et mis à la terre conformément à ce mode d'emploi.
- En cas d'interférences après avoir pris les mesures précédentes, il incombe à l'utilisateur de prendre des mesures supplémentaires telles que le déplacement du poste, l'utilisation de câbles blindés, l'utilisation de filtres de ligne ou la pose de protecteurs dans la zone de travail.

## 2-6. Proposition californienne 65 Avertissements

**⚠ AVERTISSEMENT – ce produit peut vous exposer à des produits chimiques tels que le plomb, reconnus par l'État de Californie comme cancérigènes et sources de malformations ou d'autres troubles de la reproduction.**

Pour plus d'informations, consulter [www.P65Warnings.ca.gov](http://www.P65Warnings.ca.gov).

**Pour les moteurs diesel :**

**⚠ AVERTISSEMENT – les gaz d'échappement de moteurs diesel vous exposent à des produits chimiques, reconnus par l'État de Californie comme cancérigènes et sources de malformations ou d'autres troubles de la reproduction.**

- Toujours démarrer et faire tourner le moteur dans une zone bien aérée.
- Si la zone est fermée, diriger l'échappement vers l'extérieur.
- Ne pas modifier ni altérer le système d'échappement.
- Ne pas faire tourner le moteur au ralenti, sauf si nécessaire.

Pour plus d'informations, consulter [www.P65Warnings.ca.gov/diesel](http://www.P65Warnings.ca.gov/diesel).

## 2-7. Principales normes de sécurité

*Safety in Welding, Cutting, and Allied Processes*, American Welding Society standard ANSI Standard Z49.1. Website: [www.aws.org](http://www.aws.org).

*Safe Practices for the Preparation of Containers and Piping for Welding and Cutting*, American Welding Society Standard AWS F4.1. Website: [www.aws.org](http://www.aws.org).

*National Electrical Code*, NFPA Standard 70 from National Fire Protection Association. Website: [www.nfpa.org](http://www.nfpa.org).

*Safe Handling of Compressed Gases in Cylinders*, CGA Pamphlet P-1 from Compressed Gas Association. Website: [www.cganet.com](http://www.cganet.com).

*Safety in Welding, Cutting, and Allied Processes*, CSA Standard W117.2 from Canadian Standards Association. Website: [www.csa-group.org](http://www.csa-group.org).

*Battery Chargers*, CSA Standard C22.2 NO 107.2-01 from Canadian Standards Association. Website: [www.csagroup.org](http://www.csagroup.org).

*Safe Practice For Occupational And Educational Eye And Face Protection*, ANSI Standard Z87.1, from American National Standards Institute. Website: [safetyequipment.org](http://safetyequipment.org).

*Standard for Fire Prevention During Welding, Cutting, and Other Hot Work*, NFPA Standard 51B from National Fire Protection Association. Website: [www.nfpa.org](http://www.nfpa.org).

OSHA, Occupational Safety and Health Standards for General Industry, Title 29, Code of Federal Regulations (CFR), Part 1910.177 Subpart N, Part 1910 Subpart Q, and Part 1926, Subpart J. Website: [www.osha.gov](http://www.osha.gov).

*OSHA Important Note Regarding the ACGIH TLV, Policy Statement on the Uses of TLVs and BEIs*. Website: [www.osha.gov](http://www.osha.gov).

*Portable Generator Hazards Safety Alert* from U.S. Consumer Product Safety Commission (CPSC). Website: [www.cpsc.gov](http://www.cpsc.gov).

*Applications Manual for the Revised NIOSH Lifting Equation* from the National Institute for Occupational Safety and Health (NIOSH). Website: [www.cdc.gov/NIOSH](http://www.cdc.gov/NIOSH).

For Standards regulating hydraulic systems, contact the National Fluid Power Association. Website: [www.nfpa.com](http://www.nfpa.com).

*Battery Service Manual* from the Battery Council International. Website: [www.batterycouncil.org](http://www.batterycouncil.org).

ROM\_fre 2024-01

## 2-8. Informations relatives aux CEM

Le courant électrique qui traverse tout conducteur génère des champs électromagnétiques (CEM) à certains endroits. Le courant issu d'un soudage à l'arc (et de procédés connexes, y compris le soudage par points, le gougeage, le découpage plasma et les opérations de chauffage par induction) crée un champ électromagnétique (CEM) autour du circuit de soudage. Les champs électromagnétiques produits peuvent causer interférence à certains implants médicaux, p. ex. les stimulateurs cardiaques. Des mesures de protection pour les porteurs d'implants médicaux doivent être prises: par exemple, des restrictions d'accès pour les passants ou une évaluation individuelle des risques pour les soudeurs. Tous les soudeurs doivent appliquer les procédures suivantes pour minimiser l'exposition aux CEM provenant du circuit de soudage:

1. Rassembler les câbles en les torsadant ou en les attachant avec du ruban adhésif ou avec une housse.
2. Ne pas se tenir au milieu des câbles de soudage. Disposer les câbles d'un côté et à distance de l'opérateur.
3. Ne pas courber et ne pas entourer les câbles autour de votre corps.
4. Maintenir la tête et le torse aussi loin que possible du matériel du circuit de soudage.
5. Connecter la pince sur la pièce aussi près que possible de la soudure.
6. Ne pas travailler à proximité d'une source de soudage, ni s'asseoir ou se pencher dessus.
7. Ne pas souder tout en portant la source de soudage ou le dévidoir.

### En ce qui concerne les implants médicaux :

Les porteurs d'implants doivent d'abord consulter leur médecin avant de s'approcher des opérations de soudage à l'arc, de soudage par points, de gougeage, du coupage plasma ou de chauffage par induction. Si le médecin approuve, il est recommandé de suivre les procédures précédentes.







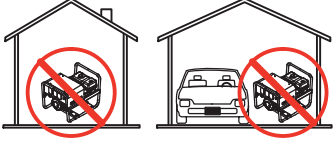
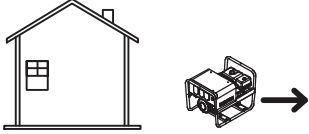









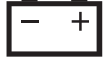



## SECTION 3 – DEFINITIONS



### 3-1. Additional Safety Symbol Definitions

 Some symbols are found only on CE products.

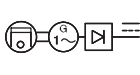
	<p>Warning! Watch Out! There are possible hazards as shown by the symbols.</p>
	<p>Never use generator inside a home or garage, even if doors and windows are open.</p>
	<p>Only use generator outside and far away from windows, doors, and vents.</p>

### 3-2. Miscellaneous Symbol Definitions

<b>A</b>	Amperage		Alternating Current (AC)		Run (Fast)
<b>V</b>	Voltage		Protective Earth (Ground)		Engine
<b>S</b>	Seconds		Output		Air Filter
<b>U<sub>0</sub></b>	Rated No-Load Voltage (OCV)		Work Connection		Battery (Engine)
<b>U<sub>2</sub></b>	Conventional Load Voltage		Engine Temperature		Fuel
<b>I<sub>2</sub></b>	Rated Welding Current		Circuit Breaker Supplementary Protector		Engine Oil
<b>h</b>	Hours		Clock		Check Valve Clearance
<b>X</b>	Duty Cycle		Engine Choke		Call for Maintenance
<b>-</b>	Negative		Engine Start		Read Operator's Manual
<b>+</b>	Positive		Engine Stop		Engine-Driven Generator with Rectifier
<b>≡</b>	Direct Current (DC)		Idle (Slow)		Do Not Switch While Welding

	Shielded Metal Arc Welding (SMAW)
	Welding

	Single Phase Alternator
<b>Hz</b>	Hertz

	Single Phase
---	--------------

## SECTION 4 – SPECIFICATIONS

### 4-1. Serial Number And Rating Label Location

The serial number for this product is located on the front. The rating information for this product is located on the back. Use rating label to determine input power requirements and/or rated output. For future reference, write serial number in space provided on back cover of this manual.

### 4-2. Information About Default Weld Parameters And Settings

**NOTICE** – Each welding application is unique. Although certain Hobart products are designed to determine and default to certain typical welding parameters and settings based upon specific and relatively limited application variables input by the end user, such default settings are for reference purposes only; and final weld results can be affected by other variables and application-specific circumstances. The appropriateness of all parameters and settings should be evaluated and modified by the end user as necessary based upon application-specific requirements. The end user is solely responsible for selection and coordination of appropriate equipment, adoption or adjustment of default weld parameters and settings, and ultimate quality and durability of all resultant welds. Hobart expressly disclaims any and all implied warranties including any implied warranty of fitness for a particular purpose.

### 4-3. Weld, Power, And Carbureted Engine Specifications

This equipment will deliver rated output at an ambient air temperature up to 104°F (40°C).

Welding Mode	Rated Welding Output 100% Duty Cycle at 40° C	Maximum Open-Circuit Voltage	Weld Output Range	Generator Power Rating	Fuel Capacity	Engine	Fuel Type
CC/DC	225A, 29V*	94.5V	20–235A	<b>Peak:</b> 10.0 kVA/kW <b>Continuous:</b> 9.5 kVA/kW, 40 A, 240 V AC, 20 A, 120 V AC, 60 Hz Single-Phase	11 Gallons (42 L)	Vanguard 23 HP Air-Cooled, Two Cylinder, Four- Cycle, 23 HP Gasoline Engine	Gasoline Up to 10% Ethanol

\* Meets NEMA and IEC Ratings.

### 4-4. Environmental Specifications

#### A. IP Rating

IP Rating
IP23S
This equipment is designed for outdoor use. It may be stored, but is not intended to be used for welding outside during precipitation unless sheltered.

#### B. Temperature Specifications

Operating Temperature Range*	Storage/Transportation Temperature Range
–20 to 104°F (–29 to 40°C)	–40 to 131°F (–40 to 55°C)

\*Output is derated at temperatures above 104°F (40°C).

## 4-5. Base Unit Dimensions, Weights, And Operating Angles

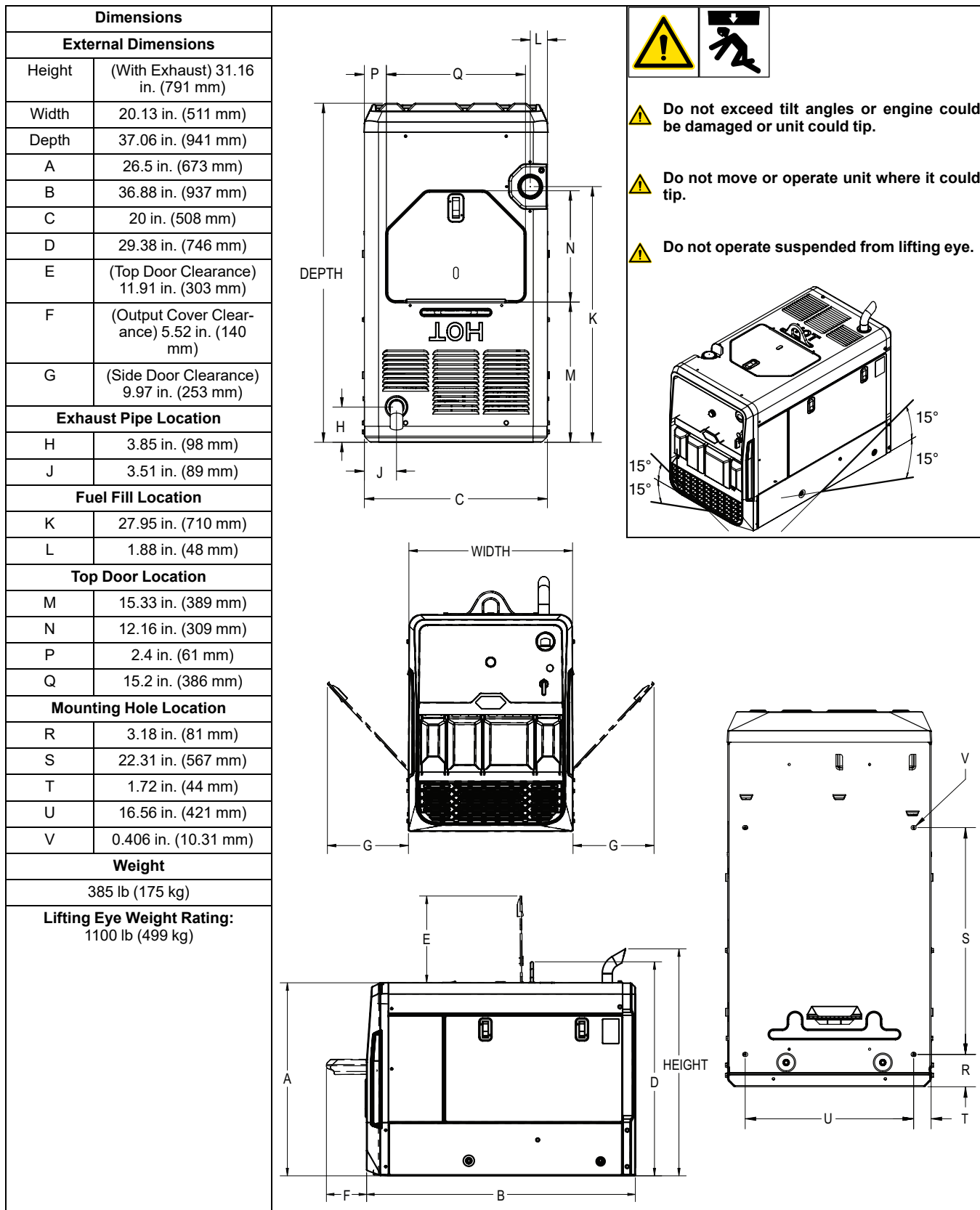

## 4-6. Duty Cycle And Overheating



### 100% Duty Cycle at 225 Amperes DC

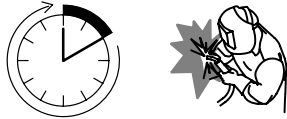

Continuous Welding

Duty cycle is the percentage of 10 minutes that unit can weld at rated load without overheating.

*This unit is rated for welding at 225 amperes continuously.*

**NOTICE** – Exceeding duty cycle can damage unit and void warranty.

### Overheating

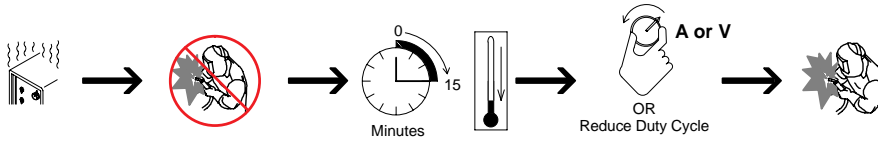

## 4-7. Volt-Ampere Curves

### STICK (CC Mode)

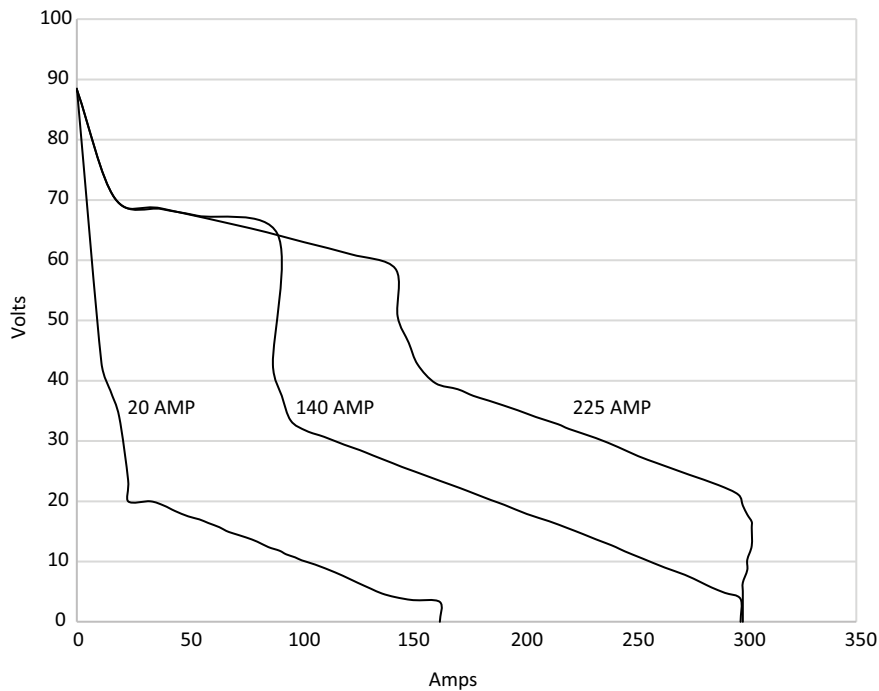

The volt-ampere curve shows the minimum and maximum voltage and amperage output capabilities of the welding generator. Curves of all other settings fall between the curves shown.

## 4-8. Fuel Consumption

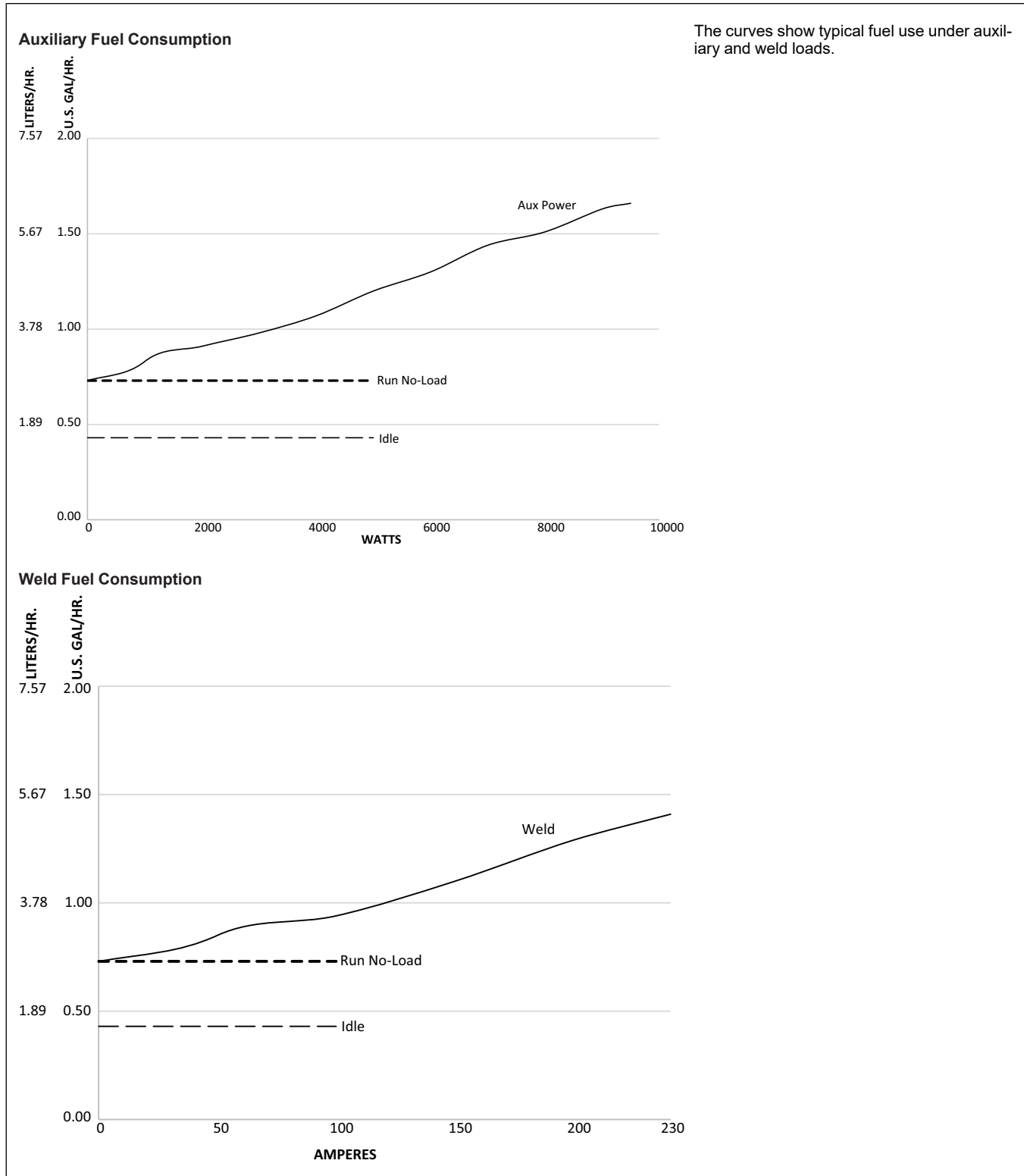

## SECTION 5 – INSTALLATION

### 5-1. Installing Welder/Generator



#### Movement

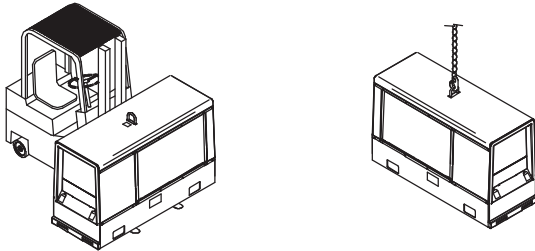

- Do not move or operate unit where it could tip.
- Do not lift unit from end.
- Do not weld on base. Welding on base can cause fuel tank fire or explosion. Bolt unit down using holes provided in base.
- Always securely fasten welding generator onto transport vehicle or trailer and comply with all DOT and other applicable codes.

**NOTICE** – Do not install unit where airflow is restricted or engine may overheat.

See Specifications for lifting eye rating.

#### Location/Airflow Clearance

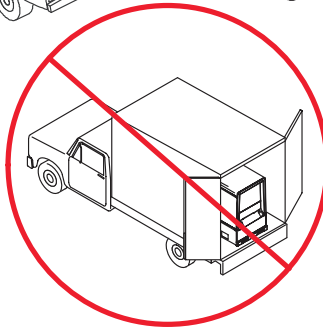
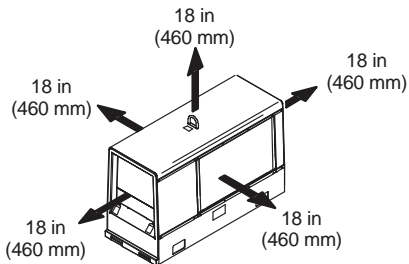
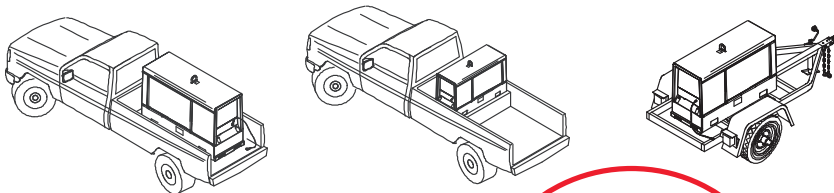

#### Mounting:

- Do not mount unit by supporting the base only at the four mounting holes. Do not use flexible mounts. Use cross-supports to adequately support unit and prevent damage to base.

#### 1 Cross-Supports

Mount unit on flat surface or use cross-supports to support base.

Go to [MillerWelds.com](http://MillerWelds.com) for more information on truck installations.

#### Mounting

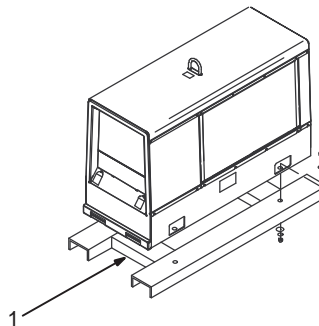
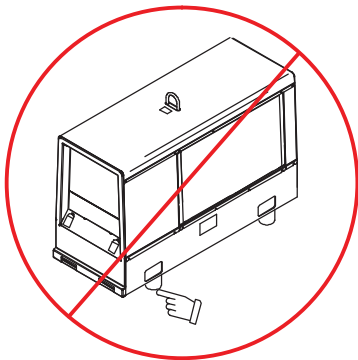

## 5-2. Grounding Generator to Truck or Trailer Frame

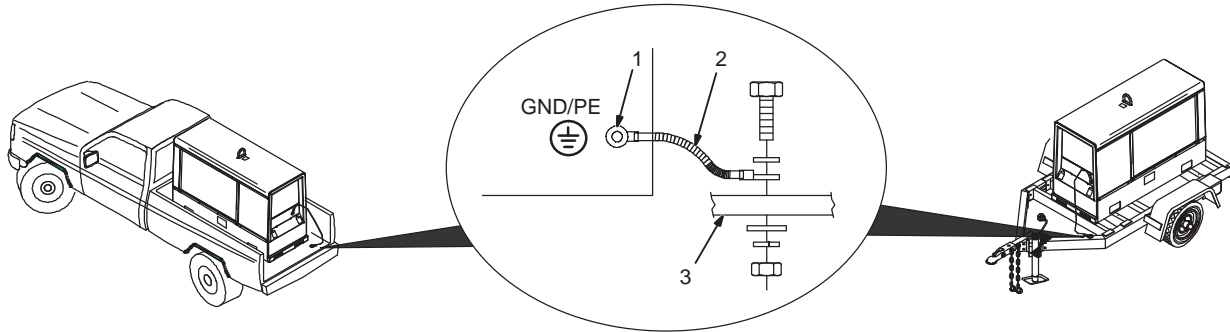

**⚠** Always ground generator frame to vehicle frame to prevent electric shock and static electricity hazards.

**⚠** Also see AWS Safety & Health Fact Sheet No. 29, Grounding of Portable And Vehicle Mounted Welding Generators.

**⚠** Bed liners, shipping skids, and some running gear insulate the welding generator from the vehicle frame. Always connect a ground wire from the generator equipment grounding terminal to bare metal on the vehicle frame as shown.

- 1 Equipment Grounding Terminal (On Front Panel)
- 2 Grounding Cable (Not Supplied)
- 3 Metal Vehicle Frame

Connect cable from equipment ground terminal to metal vehicle frame. Use #8 AWG or larger insulated copper wire.

*☞ Electrically bond generator frame to vehicle frame by metal-to-metal contact.*

## 5-3. Ground Cable Routing

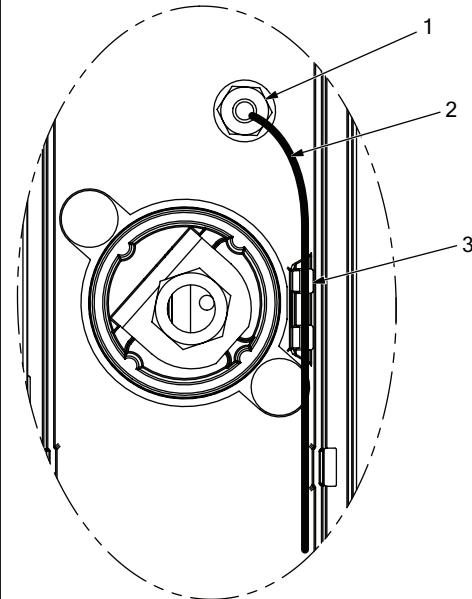

*☞ See Section 5-2 prior to routing grounding wire.*

- 1 Equipment Grounding Stud
- 2 Grounding Cable
- 3 Grounding Cable Retention Clip



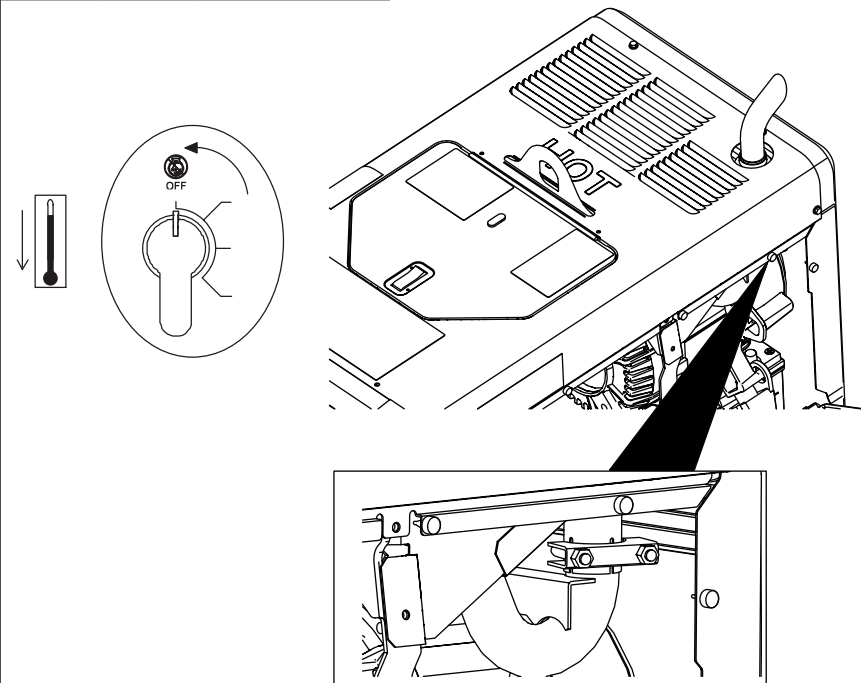

Route cable from equipment grounding terminal to metal frame through cable retention clip.

Use #8 AWG insulated copper wire.

## 5-4. Installing Exhaust Pipe



 1/2 in.

-  Stop engine and let cool.
-  Engine backfire can cause severe burns or other injuries. Do not point exhaust pipe toward control panel. Keep away from exhaust outlet.
-  Do not point exhaust pipe toward LP fuel tank (if equipped). Do not point exhaust pipe towards shielding gas tank (if equipped).
-  Point exhaust pipe in desired direction but always away from front panel and direction of travel.

## 5-5. Engine Prestart Checks

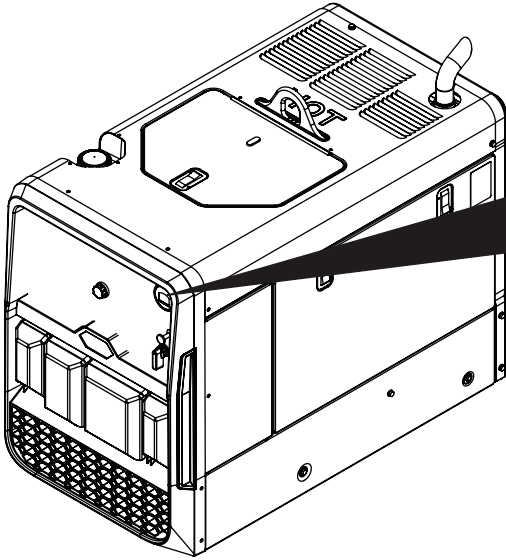

Check all fluids daily. Engine must be cold and on a level surface. Unit is shipped with synthetic blend 10W-30 engine oil.

☞ Follow run-in procedure in engine manual.

☞ This unit has a low oil pressure shut-down switch. However, some conditions may cause engine damage before the engine shuts down. Check oil level often and do not use the oil pressure shutdown system to monitor oil level.

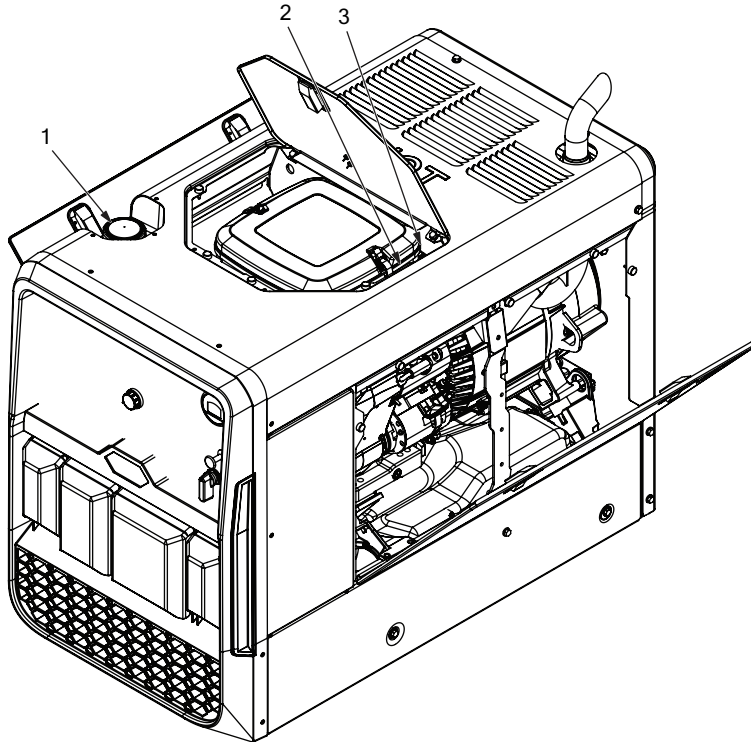

### Fuel

#### 1 Fuel Fill Cap

Add fresh fuel before starting engine the first time (see maintenance label for specifications). Stop fueling when fuel reaches bottom of fuel fill bowl. Do not overfill. Fuel tank has built in air expansion volume. Do not top off tank. Check fuel level on a cold engine before use each day.

To check fuel level, turn Engine Control switch to Run/Idle position. Fuel/hourmeter indicates fuel level in tank.

### Oil

Open top service door.

#### 2 Oil Fill

#### 3 Oil Check

☞ Do not exceed the "Full" mark on the oil level dipstick. The fuel pump may operate erratically if crankcase is overfilled.

After fueling, check oil with unit on level surface. If oil is not up to full mark on dipstick, add oil (see maintenance label).

Use fuel/hourmeter to determine hours until next recommended oil change (see Front Panel Controls).

☞ To improve cold weather starting:  
Keep battery in good condition.  
Store battery in warm area.  
Use correct grade oil for cold weather.

Close top service door.

## 5-6. Connecting Or Replacing The Battery

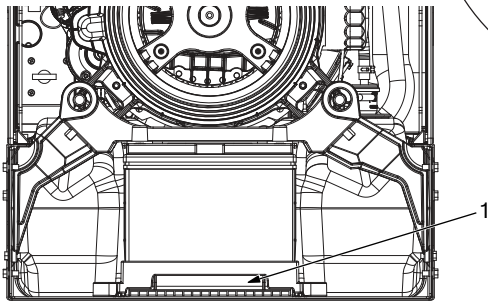
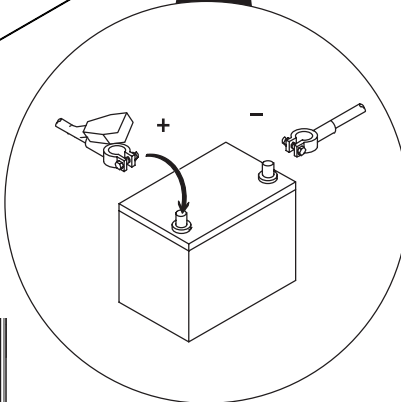
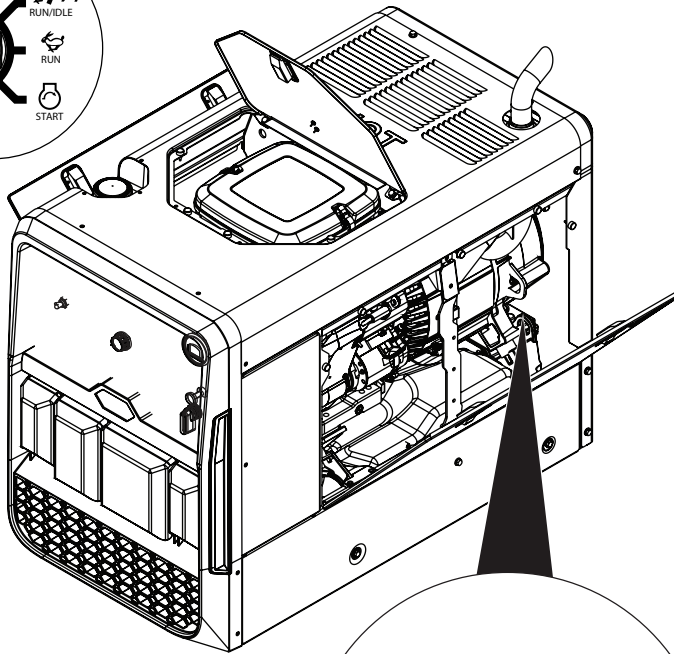
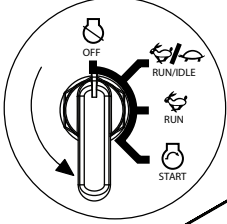

 3/8, 1/2 in.

 **Connect negative (-) battery cable last.**

Battery is most easily accessed through the side door. Connect battery, negative cable last. Close access door.

- Do not allow the battery cables to touch opposing terminals. When connecting the battery cables attach the positive (+) cable to the positive (+) battery terminal first, followed by negative (-) cable to negative (-) battery terminal.
- Never start the engine when the cables are loose or poorly connected to the battery terminals.
- Never disconnect the battery while the engine is running.
- Never use a quick battery charger to start the engine.
- Do not charge battery with Engine Control switch On.
- Always disconnect the negative (-) battery cable before charging battery.

### 1 Battery Holddown

To change battery, remove rear panel and battery holddown.

Be sure battery cables are not pinched when installing battery and replacing rear panel.

## 5-7. Weld Output Terminals

- Stop engine.**
- Turn off power before connecting to weld output terminals.**
- Do not use worn, damaged, undersized, or repaired cables.**

1 Positive Weld Output Terminal  
2 Negative Weld Output Terminal

Connect electrode or torch cable to positive terminal for Direct Current Electrode Positive (DCEP) or the negative terminal for Direct Current Electrode Negative (DCEN).

See Section 6-3 for typical process connections and control settings.

## 5-8. Connecting Weld Output Cables

- Stop engine.**
- Failure to properly connect weld cables may cause excessive heat and start a fire, or damage your machine.**

Do not place anything between weld cable terminal and copper bar. Make sure that the surfaces of the weld cable terminal and copper bar are clean.

1 Correct Weld Cable Connection  
2 Incorrect Weld Cable Connection  
3 Weld Output Terminal  
4 Supplied Weld Output Terminal Nut  
5 Weld Cable Terminal  
6 Copper Bar

Remove supplied nut from weld output terminal. Slide weld cable terminal onto weld output terminal and secure with nut so that weld cable terminal is tight against copper bar.

3/4 in. (19 mm)

## 5-9. Selecting Cable Sizes\*

**NOTICE** – The Total Cable Length in Weld Circuit (see table below) is the combined length of both weld cables. For example, if the power source is 100 ft (30 m) from the workpiece, the total cable length in the weld circuit is 200 ft (2 cables x 100 ft). Use the 200 ft (60 m) column to determine cable size.

	Weld Cable Size** and Total Cable (Copper) Length in Weld Circuit Not Exceeding***							
	100 ft (30 m) or Less		150 ft (45 m)	200 ft (60 m)	250 ft (70 m)	300 ft (90 m)	350 ft (105 m)	400 ft (120 m)
Welding Amperes	10 - 60% Duty Cycle AWG (mm <sup>2</sup> )	60 - 100% Duty Cycle AWG (mm <sup>2</sup> )	10 - 100% Duty Cycle AWG (mm <sup>2</sup> )					
100	4 (20)	4 (20)	4 (20)	3 (30)	2 (35)	1 (50)	1/0 (60)	1/0 (60)
150	3 (30)	3 (30)	2 (35)	1 (50)	1/0 (60)	2/0 (70)	3/0 (95)	3/0 (95)
200	3 (30)	2 (35)	1 (50)	1/0 (60)	2/0 (70)	3/0 (95)	4/0 (120)	4/0 (120)
250	2 (35)	1 (50)	1/0 (60)	2/0 (70)	3/0 (95)	4/0 (120)	2x2/0 (2x70)	2x2/0 (2x70)
300	1 (50)	1/0 (60)	2/0 (70)	3/0 (95)	4/0 (120)	2x2/0 (2x70)	2x3/0 (2x95)	2x3/0 (2x95)

\* This chart is a general guideline and may not suit all applications. If cable overheats, use next size larger cable.

\*\*Weld cable size (AWG) is based on either a 4 volts or less drop or a current density of at least 300 circular mils per ampere. ( ) = mm<sup>2</sup> for metric use.

\*\*\*For distances longer than those shown in this guide, see AWS Fact Sheet No. 39, Welding Cables, available from the American Welding Society at <http://www.aws.org>.

# SECTION 6 – OPERATION

## 6-1. Front Panel Controls

**Champion® Elite 225**

**ELECTRODE SIZE**

- 3/32"
- 1/8"
- 5/32"

**1** Engine Control Switch

Use switch to start engine, select speed, and stop engine. In Run/Idle position, engine runs at idle speed at no load, and weld/power speed under load. In Run position, engine runs at weld/power speed.

**To Start:** Pull out choke and turn Engine Control switch to Start position. Release switch when engine starts. Slowly push in choke.

*If the engine does not start, let engine come to a complete stop before attempting restart.*

*During cold weather some gasoline engines encounter difficulties that are easily remedied. See Section 6-4 and Troubleshooting Tables.*

**To Stop:** Turn Engine Control switch to Off position.

**2** Engine Hour Meter/Fuel Gauge/Idle Control

Low fuel is indicated by a fuel icon flashing in the center of the display.

A maintenance interval is reached when the wrench icon appears in the display.

Hour Meter: With engine off, place Engine Control switch in Run/Idle position to view engine hours.

Oil Change Interval: With engine off, place Engine Control switch in the Run position to see hours before next oil change. Oil hours start at 100 and count down to 0 (zero) (oil change due).

**3** Ampere Setting

Use control to select weld amperage.

Ranges for common electrode sizes are shown on exterior of dial.

*See Section 6-3 for typical process connections and control settings.*

**4** Choke

Use control to control fuel flow during cold engine starts.

*Negative hours indicated when past recommended oil change interval.*

To reset, cycle Engine Control switch from Run/Idle to Run three times within five seconds (engine off).

## 6-2. Fuel/Hour Gauge Descriptions

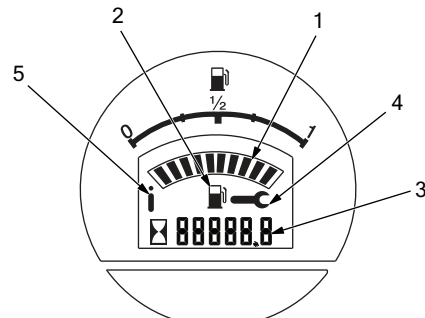

1	Fuel Gauge	Shows fuel level.
2	Low Fuel Warning	Flashes when fuel level is low.
3	Hour Display	With engine off and engine control switch in "RUN/IDLE" position, displays engine hours. See Section 6-1 for more information.
	Oil Change Interval	With engine off and engine control switch in "RUN" position, displays remaining hours to next oil change. Past due will display negative hours to -99.
4	Oil Change Indicator	Flashes when oil change is due. To Reset: While engine is off, toggle engine control switch between "RUN/IDLE" and "RUN" positions three times within 5 seconds.
5	Fault Indicator	Illuminates if error is present. See Section Fault Indicator if illuminated.

## 6-3. Typical Stick Welding Connections And Control Settings



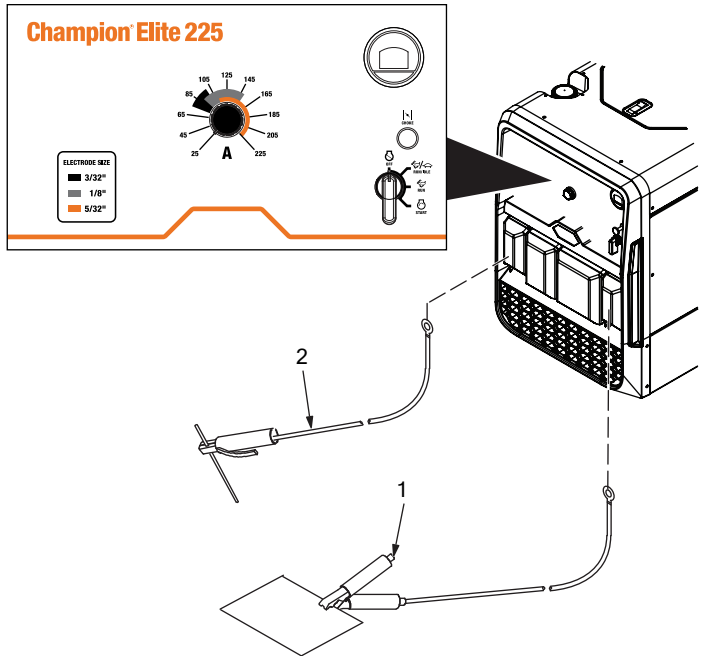

**Champion Elite 225**

ELECTRODE SIZE

- 3/32"
- 1/8"
- 5/32"

Amperage scale: 70, 90, 105, 120, 140, 165, 180, 205, 225

Work Clamp (1) and Electrode Holder (2) connection diagram.

Wrench icon: 3/4 in.

**⚠ Stop engine.**

*This section provides general guidelines and may not suit all applications.*

*Consult the amperage selection tables in Section Electrode And Amperage Selection Chart for general guidance*

- 1 Work Clamp
- 2 Electrode Holder

Connect Work cable to Negative terminal and Electrode holder cable to Positive terminal on welding generator.

*Be sure to use the correct size weld cables (see Section 5-9).*

**Typical Settings For 7018 (1/8 in.) Electrode:**

- Adjust welding output between 90 and 135 amps.

*Miller recommends Hobart filler metals.*

## 6-4. Cold Weather Engine Operation

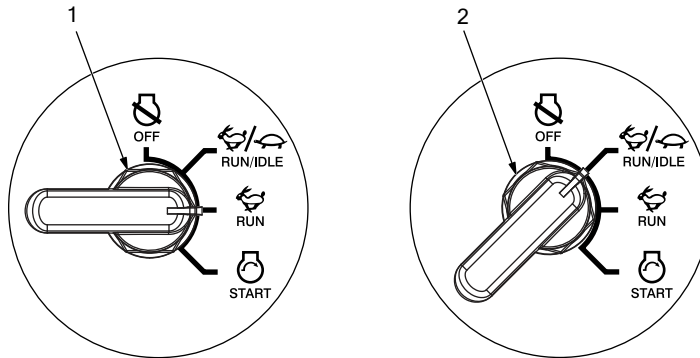
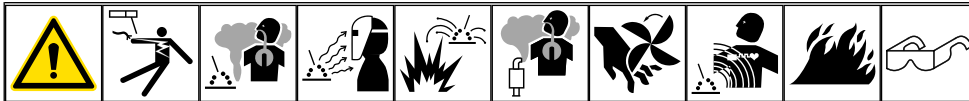

- 1 Run Position – For cold starts and engine warm up
- 2 Run/Idle Position – For use after engine is at operating temperature

### Carburetor Icing

Carburetor icing causes the unit to drop below the normal idle speed and then stall. This condition occurs when the temperature is near freezing and the relative humidity is high. Ice forms on the throttle plate and inner bore of the carburetor. The engine typically restarts without problems but soon stalls again.

- Treat gasoline with a fuel de-icer product (isopropyl alcohol).
- Place the Engine Control switch in the Run position.
- Run engine only when expecting to frequently load it.

### Breather Icing

Oil breather/pulse line icing occurs in severe cold (continuously below 0°F). Moisture accumulates in the oil from piston ring blow-by if the engine is extensively idled. This may cause vacuum line freezing, oil breather tube freezing or ice in the carburetor. All of these cause operating problems. Due to ice in the lines, the engine may not restart until it is warmed to above freezing.

- Load engine and reduce idle times to prevent engine shutdowns.
- Use an electric fuel pump to avoid pulse line freezing.
- Install engine cold-weather kit. (Kohler Only)

Kohler (1-800-544-2444) offers a kit for cold weather operation. The user can install this kit. The kit pulls heated air from the muffler

surface into the carburetor and shut the cold air off. This increases engine temperature during operation in both idle and high speed.

☞ *When the ambient temperatures become warmer (above 45°F) the air flow will have to be returned to normal.*

### Synthetic Oil

For temperatures below zero (0° F), synthetic oil improves engine starting.

☞ *Do not extend the recommended oil change interval when using synthetic oil.*

In severe cold, use synthetic grade 5W-30 oil or synthetic grade 10W-30. See engine maintenance label for additional information.

# SECTION 7 – OPERATING AUXILIARY EQUIPMENT

## 7-1. Generator Power Receptacles

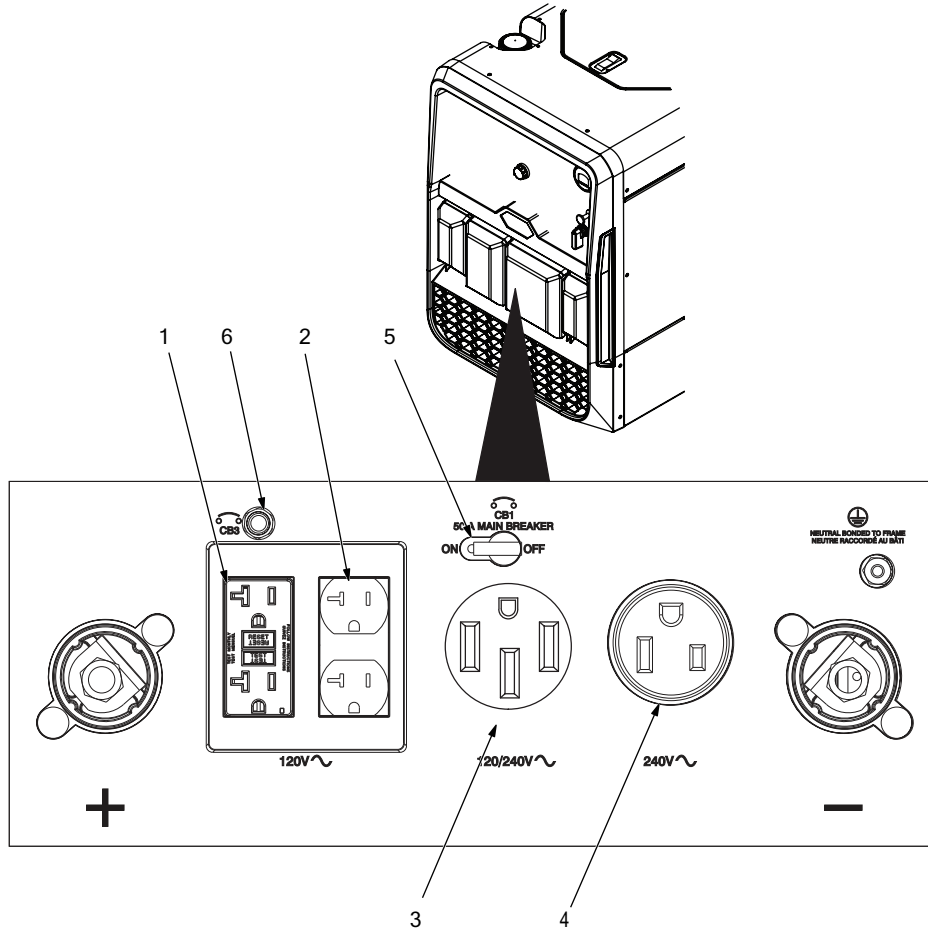

**⚠ Use GFCI protection when operating auxiliary equipment. If unit does not have GFCI receptacles, use GFCI-protected extension cord. Do not use GFCI receptacle to power life support equipment.**

**⚠ Unplug power cord before attempting to service accessories or tools.**

*☞ Generator power decreases as weld current increases.*

- 1 120 V 20 A AC Duplex Receptacle (GFCI Receptacle, protects both duplex receptacles)
- 2 120 V 20 A AC Duplex Receptacle (Non-GFCI Receptacle)
- 3 120/240 V 50 A AC Receptacle
- 4 240 V 50 A AC Receptacle

Duplex receptacles supply 120 V 60 Hz single-phase power at weld/power speed. Maximum output from duplex receptacles is 2.4 kVA/kW.

120/240 V receptacle supplies 240 V 60 Hz single-phase power at weld/power speed. Maximum output is 9.5 kVA/kW.

240 V receptacle supplies 240 V 60 Hz single-phase power at weld/power speed. Maximum output is 9.5 kVA/kW.

**⚠ Test GFCI monthly. See Section 7-2 for GFCI information and for resetting and testing procedures.**

5 Supplementary Protector CB1

CB1 protects all receptacles from overload. If CB1 opens, the receptacles do not work. Place switch in On position to reset.

6 Supplementary Protector CB3

CB3 protects duplex receptacles from overload. If a supplementary protector opens, the receptacles do not work.

*☞ Press button to reset supplementary protector. If supplementary protector continues to open, contact Factory Authorized Service Agent.*

Combined output of all receptacles limited to 9.5 kVA/kW rating of the generator.

EXAMPLE: If 20 A is drawn from a 120 V duplex receptacle, only 29 A is available at the 120/240V receptacle:

$$(120 \text{ V} \times 20 \text{ A}) + (240 \text{ V} \times 29 \text{ A}) = 9.5 \text{ kVA/kW}$$

## 7-2. GFCI Receptacle Information, Resetting, And Testing

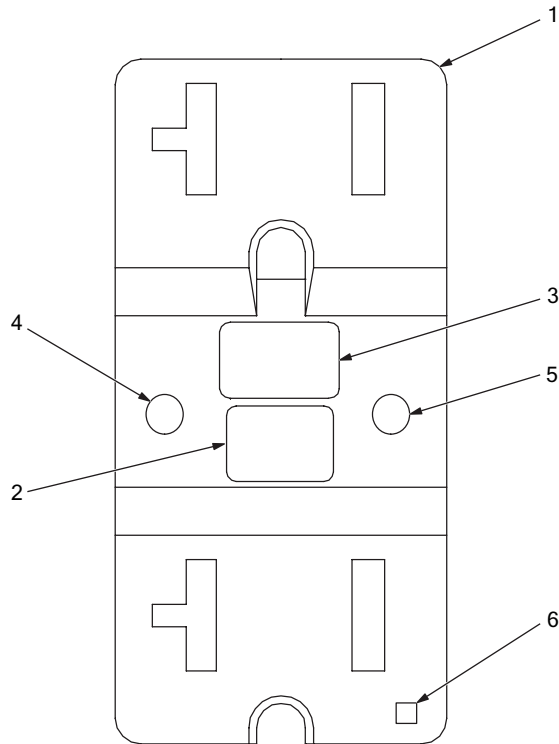

**⚠ Use GFCI protection when operating auxiliary equipment. If unit does not have GFCI receptacles, use GFCI-protected extension cord. Do not use GFCI receptacle to power life support equipment.**

**⚠ Unplug power cord before attempting to service accessories or tools.**

- 1 120 V 20 A AC GFCI Receptacle
- 2 GFCI Receptacle Test Button
- 3 GFCI Receptacle Reset Button
- 4 Red GFCI Indicator Light (LED)
- 5 Green GFCI Indicator Light (LED)
- 6 Alternate Location For Red And Green Indicator LEDs

*☞ Red and Green indicator lights may be combined in a single LED.*

*☞ Orientation of receptacle may be different in other applications.*

### GFCI Receptacles

GFCI receptacles protect the user from electric shock if a ground fault occurs in equipment connected to the receptacle. A ground fault occurs when electrical current takes the shortest path to ground (which could be through a person) rather than follow its intended safe path.

If a ground fault is detected, the GFCI Reset button pops out, and the circuit opens to disconnect power to the faulty equipment. A GFCI receptacle does not protect against circuit overloads, short circuits, or shocks not related to ground faults. Reset and test GFCI receptacle according to the following procedures.

A solid green LED indicates power to the GFCI. A solid red LED indicates that the GFCI has been tripped.

### Resetting/Testing GFCI Receptacle

- ⚠ Test GFCI monthly.**
- ⚠ If Red LED blinks, stop using GFCI receptacle and have a Factory Authorized Service Agent replace it.**
- ⚠ Extension cords with bad insulation or of extended length can allow enough leakage current to trip the GFCI circuit. Reset and test as follows.**

### Resetting GFCI Receptacles

If a GFCI fault occurs, stop engine and disconnect equipment from GFCI receptacle. Check for damaged or wet tools, cords, plugs, etc. connected to the receptacle. Start engine, place engine control switch in RUN position, and press GFCI Reset button. Reconnect equipment to GFCI receptacle. If GFCI Reset button pops out again, check the equipment and repair or replace if faulty.

### Testing GFCI Receptacles

Start engine and place engine control switch in Run position. Press the GFCI Test button. The GFCI Reset button should pop out.

Press the GFCI Reset button.

**Have a Factory Authorized Service Agent replace GFCI if any of the following occur:**

- GFCI does not trip when tested**
- Red LED blinks**
- GFCI does not reset.**

### 7-3. Simultaneous Weld And Power

Weld Current in Amperes	Total Power in Watts	120 V Full kVA (4 Wire) Receptacle Amperes	240 V Full kVA Receptacle Amperes
225	2975	25	12
180	4600	38	19
125	6300	53	26
90	7300	61	30
0	9500	79	39

### 7-4. Wiring Instructions For 240 Volt, Single-Phase Plug (NEMA 14-50P)

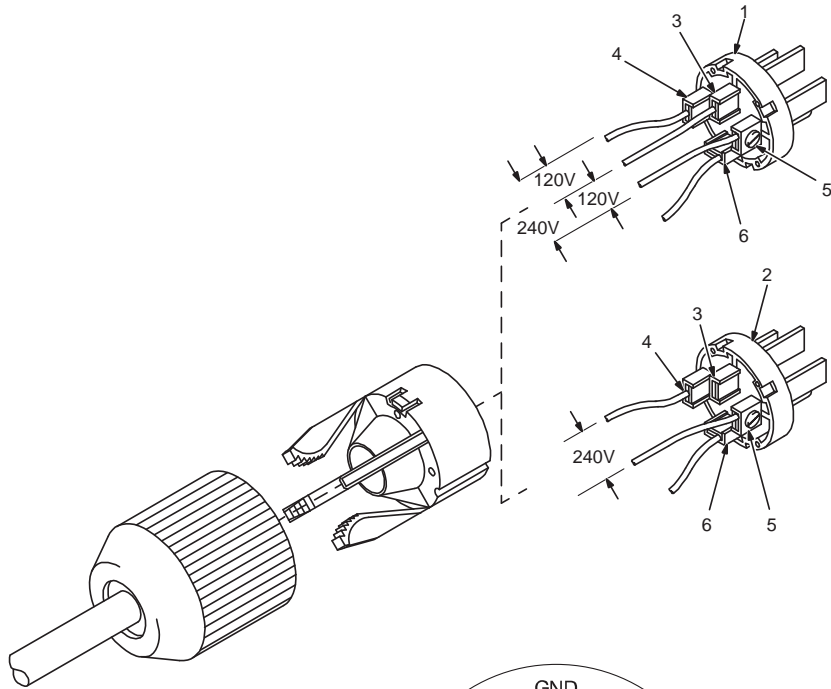

The plug can be wired for a 240 V, 2-wire load or a 120/240V, 3-wire load. See circuit diagram.

1 Plug Wired for 120/240 V, 3-Wire Load

When wired for 120 V loads, both duplex receptacle share a load with one half of 240 V receptacle.

2 Plug Wired for 240 V, 2-Wire Load

3 Neutral (Silver) Terminal

4 Load 1 (Brass) Terminal

5 Load 2 (Brass) Terminal

6 Ground (Green) Terminal

Current Available in Amperes	
240 V Receptacle*	Total 120 V Duplex Receptacles
0	20
5	20
10	20
15	20
20	20
25	20
30	20
35	10
40	0

V x A = Watts  
\*One 240 V load or two 120 V loads

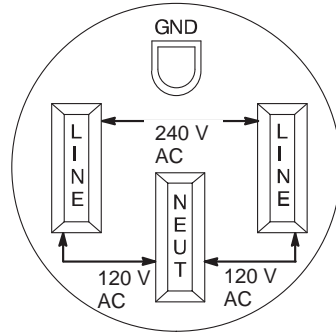

## 7-5. Wiring Instructions For 240 Volt, Single-Phase Plug (NEMA 6-50P)

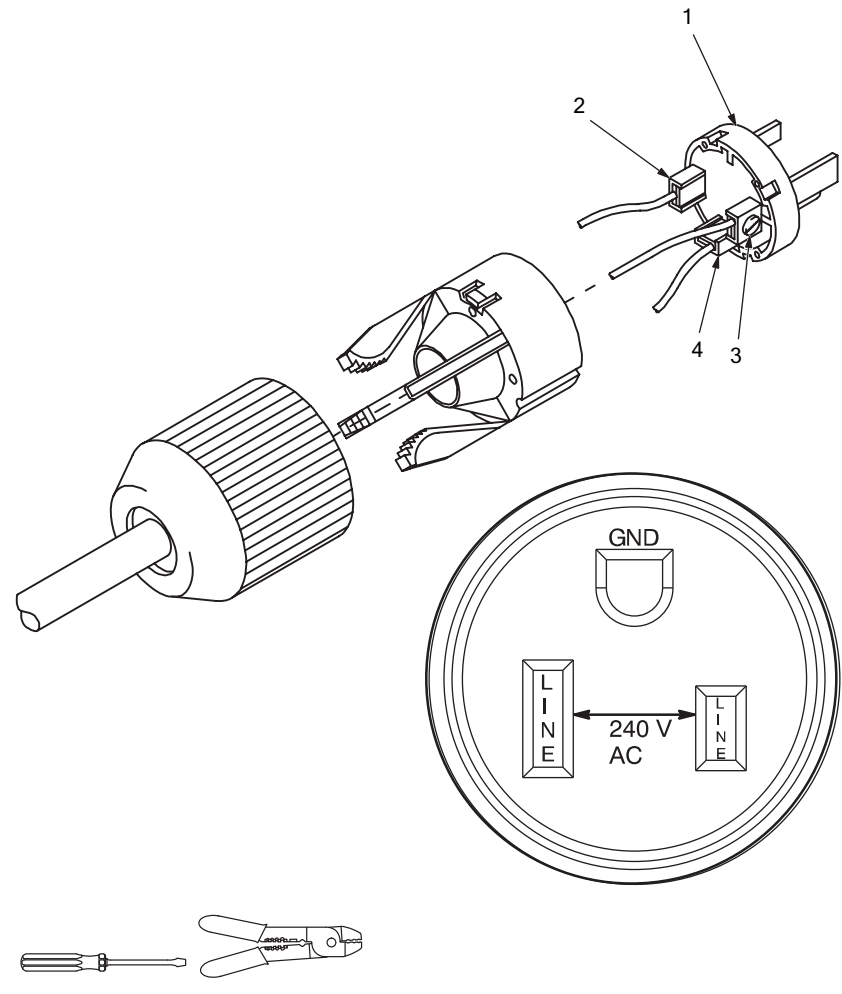

The plug can be wired for a 240 V, 2-wire load.

- 1 Plug Wired for 240 V, 2-Wire Load
- 2 Load 1 (Brass) Terminal
- 3 Load 2 (Brass) Terminal
- 4 Ground (Green) Terminal

Current Available in Amperes	
240 V Receptacle	Each 120 V Duplex Receptacle
0	20
5	20
10	20
15	20
20	20
25	20
30	20
35	10
40	0
$V \times A = \text{Watts}$	

# SECTION 8 – MAINTENANCE AND TROUBLESHOOTING

## 8-1. Routine Maintenance

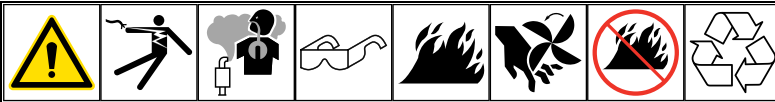

Stop engine before maintaining.

See Engine Manual and Maintenance Label for important start-up, service, and storage information. Service Engine more often if used in severe conditions.



Recycle engine fluids.

Maintenance Schedule		Every 8 Hours	Every 20 Hours	Every 25 Hours	Every 50 Hours	Every 100 Hours	Every 200 Hours	Every 500 Hours	Reference
<b>Fuel and Oil</b>	Check fuel and oil levels. Clean any fuel and/or oil spills.	•							Section 5-5
<b>Spark Arrestor Screen</b>	Check and Clean		•						Section 8-8
<b>Air Cleaner Wrapper</b>	Clean			•					Section 8-3
<b>Weld Terminals</b>	Clean				•				
<b>Battery Terminals</b>	Clean					•			
<b>Cooling System</b>	Clean					•			Engine Manual
<b>Oil and Oil Filter</b>	Change oil and replace oil filter					•			Section 8-5
<b>Air Cleaner Element</b>	Check and replace if necessary					•			Section 8-3
<b>Labels</b>	Replace any unreadable labels						•		
<b>Spark Plug</b>	Replace						•		Engine Manual
<b>Fuel Filter</b>	Replace						•		Section 8-5
<b>Weld Cables</b>	Check cables for any signs of damage and replace if necessary.							•	
<b>Brushes*</b>	Check brushes and replace if necessary							•	
<b>Slip Rings*</b>	Check slip rings for any signs of wear or damage							•	

\*To be done by factory authorized service agent.

**NOTICE** – This equipment meets US EPA Evaporative Standards. Be sure fuel system replacement parts meet EPA Evaporative standards.

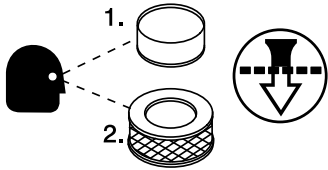
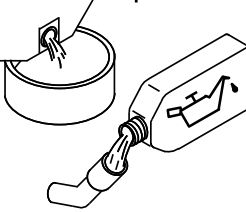
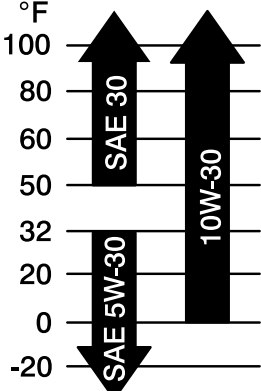
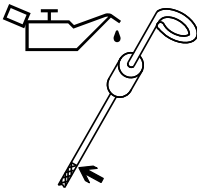
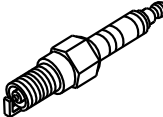
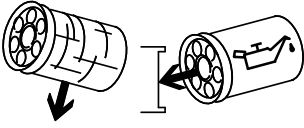
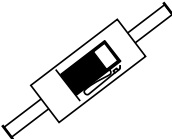
## 8-2. Maintenance Label

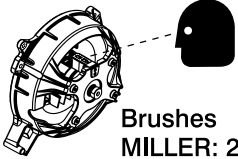
MACHINE MAINTENANCE	VANGUARD ENGINE 23 HP		
 12 V BCI 26R/99R 400 CCA	100 h 1. MILLER: 293395 Briggs & Stratton: 692520  2. MILLER: 293393 Briggs & Stratton: 692519	100 h 1.5 qt (1.4 L) Check engine dipstick. 	 °F 100 80 60 50 32 20 0 -20 SAE 30 SAE 5W-30 10W-30 API Class SJ or higher
8 h 	200 h  MILLER: 067007 Briggs & Stratton: 792015 Champion: RC-12YC Gap: 0.030 in. (.76 mm) Use only resistor spark plugs and wires.	100 h  MILLER: 293398 Briggs & Stratton: 842921	400 h  MILLER: 293397 Briggs & Stratton: 845125
GASOLINE 11 gal (42 L) Unleaded, 87 Octane min. (10% Max. Ethanol) 	1000 h  Brushes MILLER: 292189	Tune-up and Filter Kit 23 HP (Carb.): MILLER: 293399 (Includes Air, Fuel, Oil Filters, and 2 Spark Plugs) 298043-A	

## 8-3. Servicing Air Cleaner

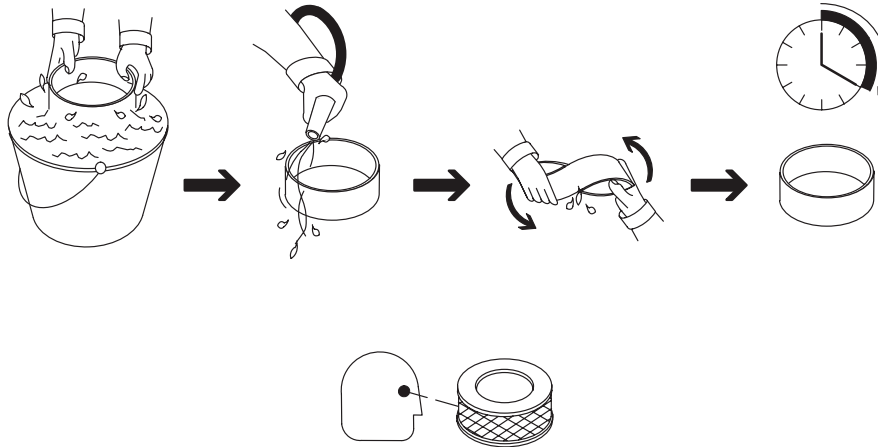
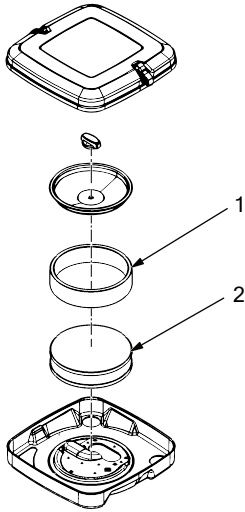

 **Stop engine.**

**NOTICE** – Do not run engine without air cleaner or with dirty element. Engine damage caused by using a damaged element is not covered by the warranty.

1 Pre-cleaner

Wash pre-cleaner with soap and water solution. Allow pre-cleaner to air dry completely.

Do not oil the pre-cleaner.

2 Element

Replace element if damaged, dirty, or oily.

## 8-4. Overload Protection

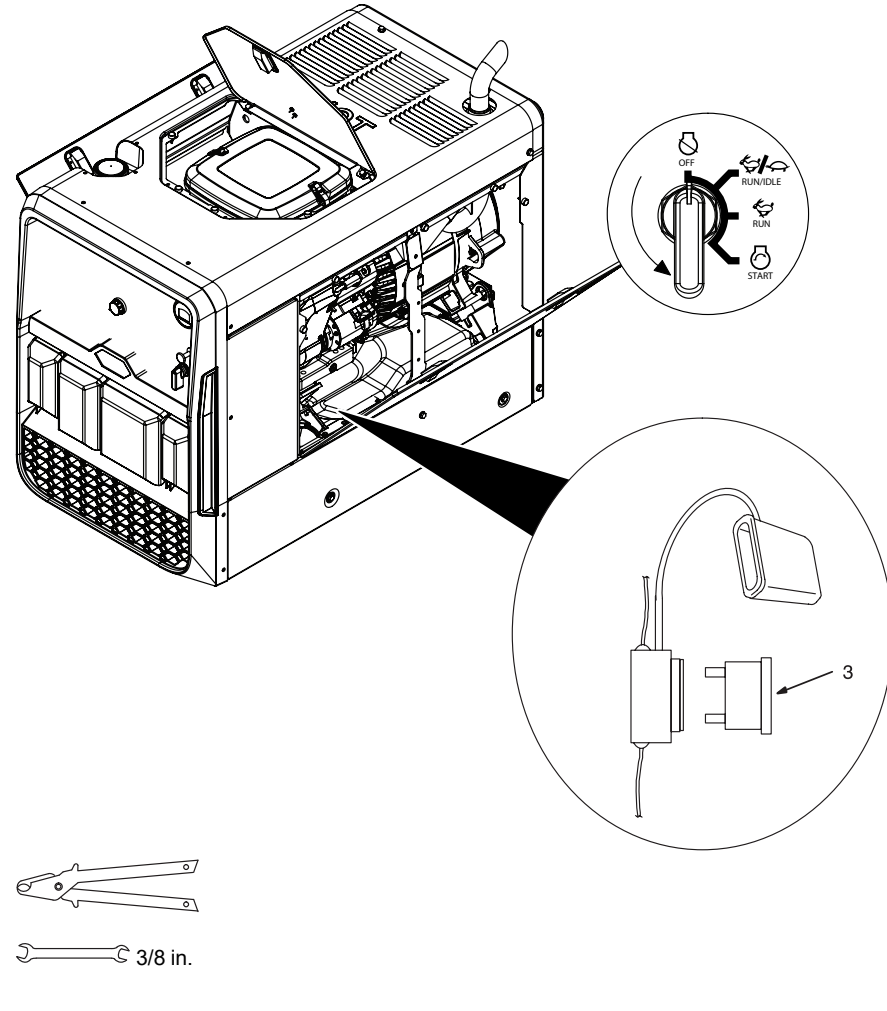

**⚠ Stop engine. Disconnect negative (-) battery cable.**

1 Fuse F6

F6 protects the engine wiring system from overload. If F6 opens, engine will not crank.

Replace any open fuses. Reinstall cover before operating.

*☞ If a fuse opens, it usually indicates a more serious problem exists. Contact a Factory Authorized Service Agent.*

## 8-5. Changing Engine Oil, Oil Filter, And Fuel Filter

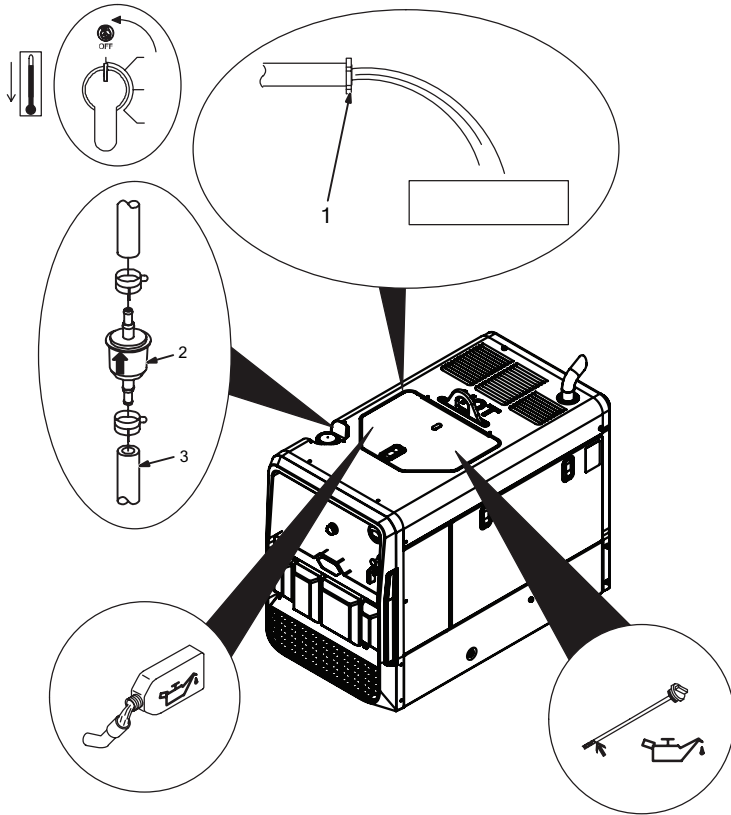

**⚠ Stop engine and let cool.**

- 1 Oil Drain Plug

Change engine oil and filter according to engine owner's manual.

**NOTICE** – Close valve and valve cap before adding oil and running engine.

Fill crankcase with new oil to full mark on dipstick (see Section 8-2).

- 2 Fuel Filter
- 3 Fuel Line

Replace line if cracked or worn. Install new filter with arrow pointing in the direction of fuel flow. Wipe up any spilled fuel.

Start engine, and check for fuel leaks.

**⚠ Stop engine, tighten connections as necessary, and wipe up fuel.**

See Section 6-2 to reset oil and oil filter maintenance countdown.

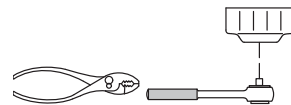

## 8-6. Adjusting Engine Speed

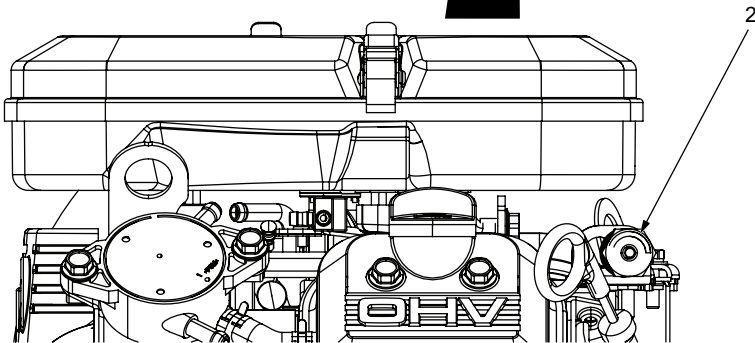
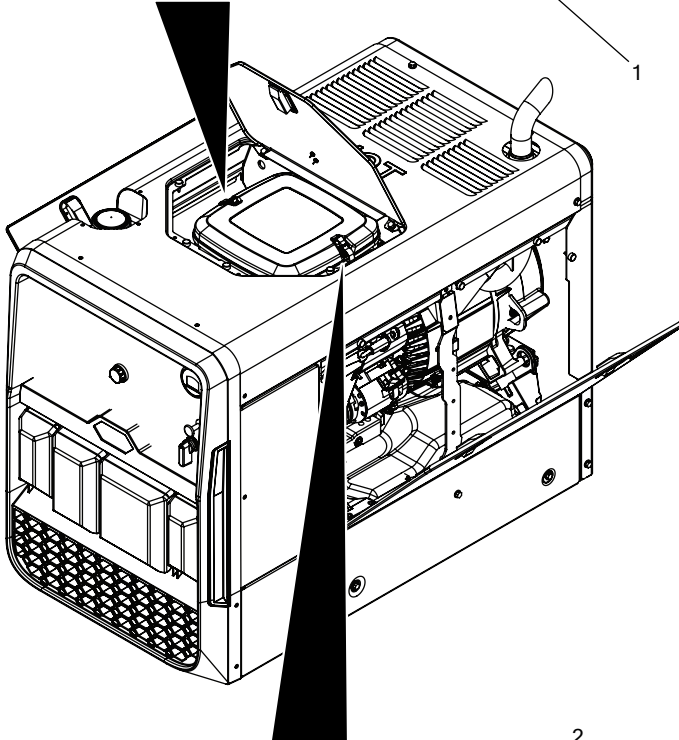
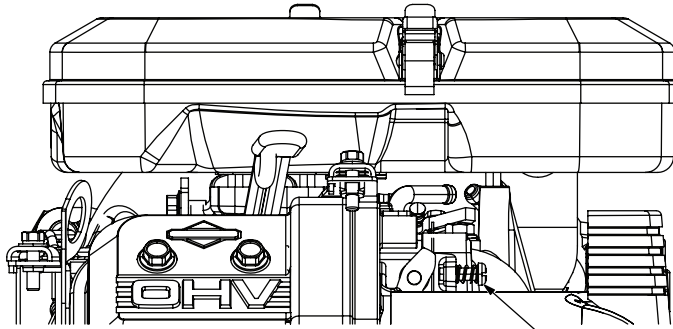
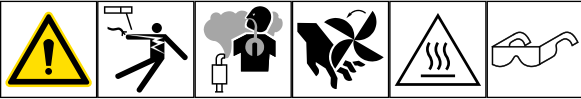

  1/4, 3/8 in.

After tuning engine, check engine speeds with a tachometer (see table). If necessary, adjust speeds as follows:

Start engine and run until warm.

Open top and side access doors.

### Idle Speed Adjustment

Move Engine Control switch to Run/Idle position.

1 Idle Speed Screw

Turn idle speed screw until engine runs at idle speed.

### Weld/Power Speed Adjustment



Move Engine Control switch to Run position.

2 Weld/Power Speed Adjustment Nut

Turn adjustment nut until engine runs at weld/power speed. Tighten lock nut.

 **Stop engine.**

Close side and top access doors.

	
	2300–2400 rpm (38.3–40.0 Hz)
	3675–3750 rpm (61.3–62.5 Hz)

## 8-7. Fault Indicator

Flash Code	Problem	Possible Cause	Potential Solution
Not Illuminated	No Fault		
Flashing	Inverter Over-Temp	Indicates the unit has overheated.	The unit has shut down to allow the fan to cool it. Operation will continue when the unit has cooled.
Illuminated Solid	Other Fault		Contact a Factory Authorized Service Agent.

## 8-8. Servicing Optional Spark Arrestor

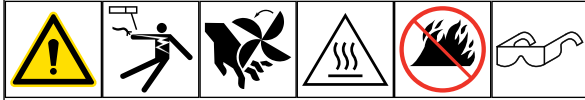

**⚠ Stop engine and let cool.**

1 Spark Arrestor Screen

Clean and inspect screen. Replace spark arrestor if screen wires are broken or missing.

## 8-9. Troubleshooting

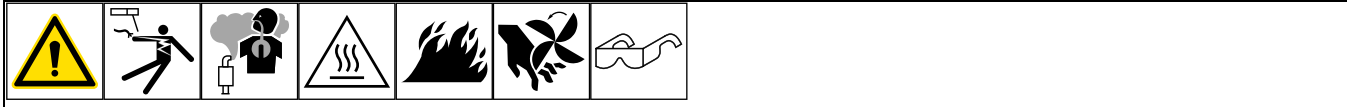

### A. Welding Troubleshooting

Trouble	Remedy
Low or no weld output; generator power output okay at AC receptacles.	Check control settings.
	Check weld connections.
	Have Factory Authorized Service Agent check brushes and slip rings.
No weld output or generator power output at AC receptacles.	Be sure all equipment is disconnected from receptacles when starting unit.
	Check plug PLG5 and RC4 connection.
	Have Factory Authorized Service Agent check brushes and slip rings.
Low weld output.	Check control settings.
	Check engine speed, and adjust if necessary (see Section 8-6).
	Service air cleaner according to engine manual.
	Have Factory Authorized Service Agent check brushes and slip rings.
High weld output.	Check control settings.
	Check engine speed, and adjust if necessary (see Section 8-6).
Erratic weld output.	Check control settings.
	Tighten and clean connections to electrode and workpiece.
	Use dry, properly-stored electrodes for Stick welding.
	Remove excessive coils from weld cables.
	Clean and tighten connections both inside and outside welding generator.
	Check engine speed, and adjust if necessary (see Section 8-6).
	Have Factory Authorized Service Agent check brushes and slip rings.

### B. Generator Power Troubleshooting

Trouble	Remedy
No or low generator power output at AC receptacles; weld output okay.	Reset supplementary protector(s) (see Section 7-1).
	Press optional GFCI receptacle Reset button (see Section 7-1).
	Check plug RC4 connection.
	Have Factory Authorized Service Agent check brushes and slip rings.
No generator power or weld output.	Be sure all equipment is disconnected from receptacles when starting unit.
	Check plug RC4 connection.
	Have Factory Authorized Service Agent check brushes and slip rings.
Low power output at AC receptacles.	Check engine speed, and adjust if necessary (see Section 8-6).
	Have Factory Authorized Service Agent check brushes and slip rings.
High power output at AC receptacles.	Check engine speed, and adjust if necessary (see Section 8-6).
Erratic power output at AC receptacles.	Check fuel level.
	Check engine speed, and adjust if necessary (see Section 8-6).
	Check receptacle wiring and connections.
	Have Factory Authorized Service Agent check brushes and slip rings.

### C. Engine Troubleshooting

Trouble	Remedy
Engine will not crank.	Check fuse F6, and replace if open (see Section 8-4).
	Check battery voltage.
	Check battery connections and tighten if necessary.
	Check plug PLG5 and plug PLG8 connections.
	Have Factory Authorized Service Agent check Engine Control switch S2.
Engine will not start.	Check fuel level.
	Check battery voltage.
	Check battery connections and tighten if necessary.
	Check oil level (see Section 5-5).
	Check low oil pressure shutdown switch.
	Have Factory Authorized Service Agent check fuel shutoff solenoid FS1 (carbureted engine only).
	Verify e-choke is operating. If not, contact engine service center.
Engine starts but stops when Engine Control switch returns to Run position.	Check oil level.
	Check and refill crankcase with proper viscosity oil for operating temperature, if necessary.
	Check low oil pressure shutdown switch.
Engine stopped during normal operation.	Check fuel level.
	Replace fuel filter(s) (see Section 8-5).
	Check oil level (see Section 5-5).
	Check low oil pressure shutdown switch.
	Periodically recharge battery (approximately every 3 months).
	Replace battery.
	Check voltage regulator and connections according to engine manual.
	Have Factory Authorized Service Agent check fuel shutoff solenoid FS1 (carbureted engine only).
Battery discharges between uses.	Clean battery, terminals, and posts with baking soda and water solution; rinse with clear water.
	Periodically recharge battery (approximately every 3 months).
	Replace battery.
	Check voltage regulator and connections according to engine manual.
Engine idles but does not come up to weld speed.	Have Factory Authorized Service Agent check fuel gauge/hourmeter/idle control, and current transformer CT1.
Unstable or sluggish engine speeds.	Readjust throttle linkage if necessary. Check throttle solenoid TS1 for smooth operation.
	Check oil level. Oil level should not exceed Full mark on dipstick. Fuel pump will operate erratically if crankcase is overfilled.
	Tune-up engine according to engine manual.
Engine does not return to idle speed.	Remove weld and generator power loads.
	Check throttle linkage for smooth, non-binding operation.
	Have Factory Authorized Service Agent check idle module, current transformer CT1, Engine Control switch S2, and throttle solenoid TS1.
During operation in near freezing temperatures, engine starts and goes to idle but stalls after a few minutes.	Treat fuel with isopropyl alcohol de-icer product.
	Place Engine Control switch in the Run position until unit has been in operation and loaded for a period of time.
During operation in severe cold weather, engine starts and goes to idle but stalls after a few minutes.	Install engine manufacturer's kit for cold-weather operation.

## SECTION 9 – PARTS LIST

### 9-1. Recommended Spare Parts

Recommended Spare Parts			
Dia. Mkgs.	Part No.	Description	Quantity
	283588	Electric Fuel Pump (High Altitude)	1
	280236	Receptacle, GFCI 15/20A	1
<b>Vanguard 23 HP</b>			
F6	239347	Fuse, 20 Amp Ato Type ( <b>Vanguard 23 HP</b> )	1
	293445	Switch, Oil Pressure ( <b>Vanguard 23 HP</b> )	1
	293446	Regulator, Voltage ( <b>Vanguard 23 HP</b> )	1
	294509	Pump, Fuel Pulse ( <b>Vanguard 23 HP</b> )	1

See Section 8-2 for common maintenance parts.

**NOTICE** – This equipment meets US EPA Evaporative Standards. Be sure fuel system replacement parts meet EPA Evaporative standards.







# SECTION 11 – GENERATOR POWER GUIDELINES

 The views in this section are intended to be representative of all engine/hydraulic-driven welder/generators. Your unit may differ from those shown.

## 11-1. Selecting Equipment



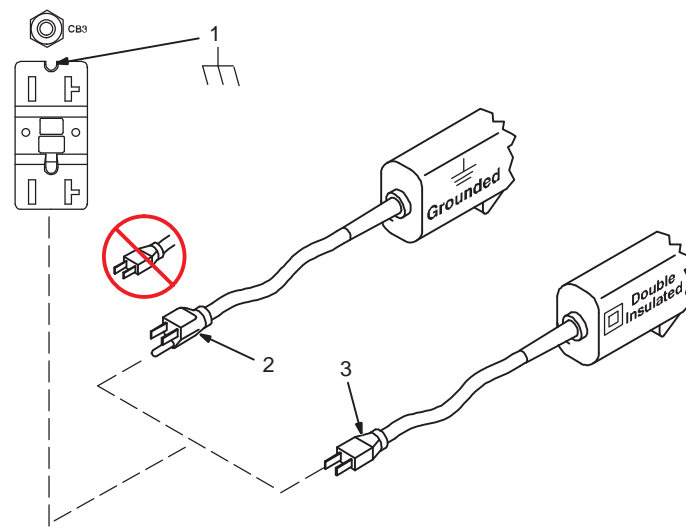



- 1 Generator Power Receptacles – Neutral Bonded To Frame
- 2 3-Prong Plug From Case Grounded Equipment

OR

- 3 2-Prong Plug From Double Insulated Equipment

 Be sure equipment has double insulated symbol and/or wording on it.

 Do not use 2-prong plug unless equipment is double insulated.

## 11-2. Grounding When Supplying Building Systems



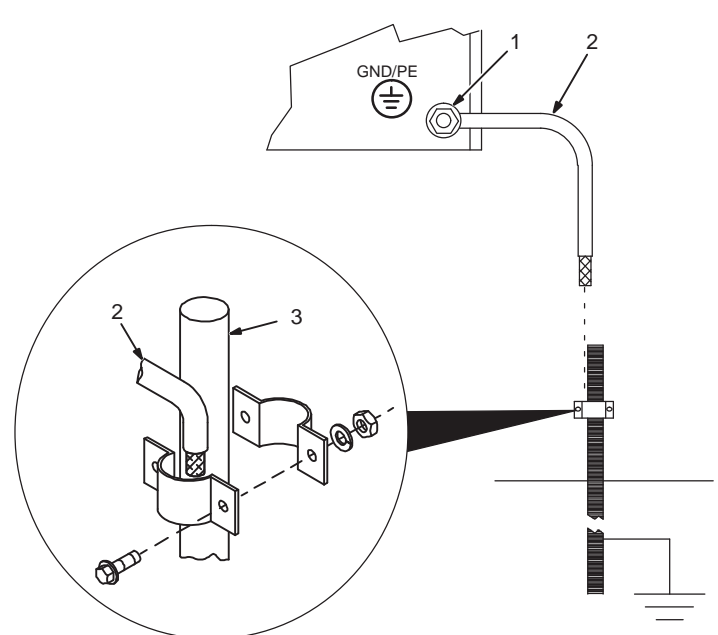



- 1 Equipment Grounding Terminal
- 2 Grounding Cable

Use #8 AWG or larger insulated copper wire.

- 3 Ground Device

 Use ground device as stated in electrical codes.

 Ground generator to system earth ground if supplying power to a premises (shop, farm) wiring system.

 Also see AWS Safety & Health Fact Sheet No. 29, Grounding of Portable And Vehicle Mounted Welding Generators.

### 11-3. How Much Power Does Equipment Require?

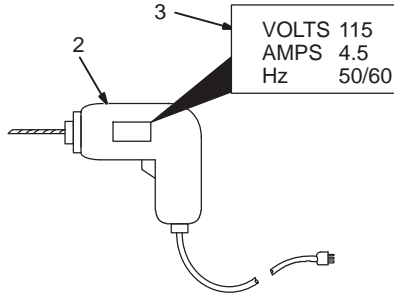
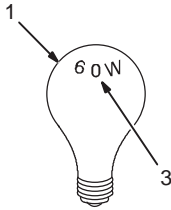

#### 1 Resistive Load

A light bulb is a resistive load and requires a constant amount of power.

#### 2 Non-Resistive Load

Equipment with a motor is a non-resistive load and requires approximately six times more power while starting the motor than when running (see Section 11-7).

#### 3 Rating Data

Rating shows volts and amperes, or watts required to run equipment.

#### Amperes x Volts = Watts

**Example 1:** If a drill uses 4.5 amperes at 115 volts, calculate its running power requirement in watts.

$$4.5 \text{ A} \times 115 \text{ V} = 520 \text{ W}$$

The load applied by the drill is 520 watts.

**Example 2:** If three 200 watt flood lamps are used with the drill from Example 1, add the individual loads to calculate total load.

$$(3 \times 200\text{W}) + 520 \text{ W} = 1120 \text{ W}$$

The total load applied by the three flood lamps and drill is 1120 watts.

### 11-4. Approximate Power Requirements For Industrial Motors

Industrial Motors	Rating	Starting Watts	Running Watts
Split Phase	1/8 HP	800	300
	1/6 HP	1225	500
	1/4 HP	1600	600
	1/3 HP	2100	700
	1/2 HP	3175	875
Capacitor Start-Induction Run	1/3 HP	2020	720
	1/2 HP	3075	975
	3/4 HP	4500	1400
	1 HP	6100	1600
	1-1/2 HP	8200	2200
	2 HP	10,550	2850
	3 HP	15,900	3900
Capacitor Start-Capacitor Run	5 HP	23,300	6800
	1-1/2 HP	8100	2000
	5 HP	23,300	6000
	7-1/2 HP	35,000	8000
Fan Duty	10 HP	46,700	10,700
	1/8 HP	1000	400
	1/6 HP	1400	550
	1/4 HP	1850	650
	1/3 HP	2400	800
	1/2 HP	3500	1100

## 11-5. Approximate Power Requirements For Farm/Shop Equipment

Farm/Shop Equipment	Rating	Starting Watts	Running Watts
Stock Tank De-Icer		1000	1000
Grain Cleaner	1/4 HP	1650	650
Portable Conveyor	1/2 HP	3400	1000
Grain Elevator	3/4 HP	4400	1400
Milk Cooler		2900	1100
Milker (Vacuum Pump)	2 HP	10,500	2800
Farm Duty Motors Std. (e.g. Conveyors, Feed Augers, Air Compressors)	1/3 HP	1720	720
	1/2 HP	2575	975
	3/4 HP	4500	1400
	1 HP	6100	1600
	1-1/2 HP	8200	2200
	2 HP	10,550	2850
	3 HP	15,900	3900
Farm Duty Motors High Torque (e.g. Barn Cleaners, Silo Unloaders, Silo Hoists, Bunk Feeders)	1-1/2 HP	8100	2000
	5 HP	23,300	6000
	7-1/2 HP	35,000	8000
	10 HP	46,700	10,700
3-1/2 cu. ft. Mixer	1/2 HP	3300	1000
High Pressure 1.8 Gal/Min	500 PSI	3150	950
Washer 2 Gal/Min	550 PSI	4500	1400
	700 PSI	6100	1600
Shallow Well Pump	1/3 HP	2150	750
	1/2 HP	3100	1000

## 11-6. Approximate Power Requirements For Contractor Equipment

Contractor Equipment	Rating	Starting Watts	Running Watts
Hand Drill	1/4 in.	350	350
	3/8 in.	400	400
	1/2 in.	600	600
Circular Saw	6-1/2 in.	500	500
	7-1/4 in.	900	900
	8-1/4 in.	1400	1400
Table Saw	9 in.	4500	1500
	10 in.	6300	1800
Band Saw	14 in.	2500	1100
Bench Grinder	6 in.	1720	720
	8 in.	3900	1400
	10 in.	5200	1600
Air Compressor	1/2 HP	3000	1000
	1 HP	6000	1500
	1-1/2 HP	8200	2200
	2 HP	10,500	2800
Electric Chain Saw	1-1/2 HP, 12 in.	1100	1100
	2 HP, 14 in.	1100	1100
Electric Trimmer	Standard 9 in.	350	350
	Heavy Duty 12 in.	500	500
Electric Cultivator	1/3 HP	2100	700
Elec. Hedge Trimmer	18 in.	400	400
Flood Lights	HID	125	100
	Metal Halide	313	250
	Mercury	1000	
	Sodium	1400	
	Vapor	1250	1000
Submersible Pump	400 GPH	600	200
Centrifugal Pump	900 GPH	900	500
Floor Polisher	3/4 HP, 16 in.	4500	1400
	1 HP, 20 in.	6100	1600
High Pressure Washer	1/2 HP	3150	950
	3/4 HP	4500	1400
	1 HP	6100	1600
55 gal Drum Mixer	1/4 HP	1900	700
Wet & Dry Vac	1.7 HP	900	900
	2-1/2 HP	1300	1300

## 11-7. Power Required To Start Motor

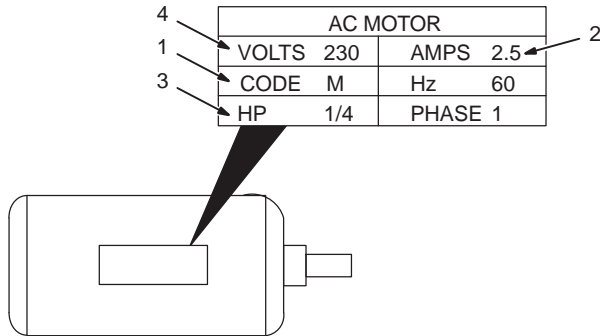

- 1 Motor Start Code
- 2 Running Amperage
- 3 Motor HP
- 4 Motor Voltage

**Step 1:** Find code and use table to find kVA/HP. If code is not listed, multiply running amperage by six to find starting amperage.

**Step 2:** Find Motor HP and Volts.

**Step 3:** Determine starting amperage (see example).

Welder/generator amperage output must be at least twice the motor's running amperage.

**(kVA/HP x HP x 1000) / Volts = Starting Amperage**

Example: Calculate starting amperage required for a 230 V, 1/4 HP motor with a motor start code of M.

Volts = 230, HP = 1/4, kVA/HP = 11.2

$(11.2 \times 1/4 \times 1000) / 230 = 12.2A$

Starting the motor requires 12.2 amperes.

**Single-Phase Induction Motor Starting Requirements**

Motor Start Code	G	H	J	K	L	M	N	P
KVA/HP	6.3	7.1	8.0	9.0	10.0	11.2	12.5	14.0

## 11-8. How Much Power Can Generator Supply?

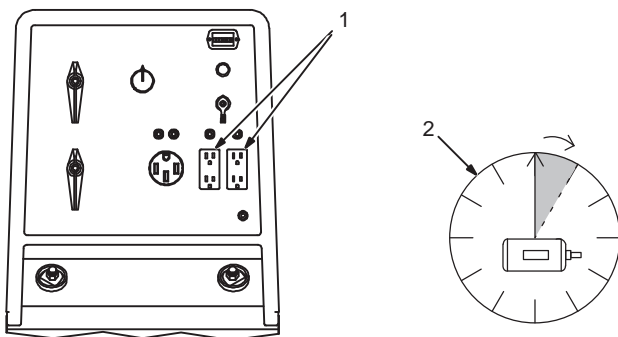

- 1 Limit Load To 90% Of Generator Output

Always start non-resistive (motor) loads in order from largest to smallest, and add resistive loads last.

- 2 5 Second Rule

If motor does not start within 5 seconds, turn off power to prevent motor damage. Motor requires more power than generator can supply.

## 11-9. Typical Connections To Standby Power

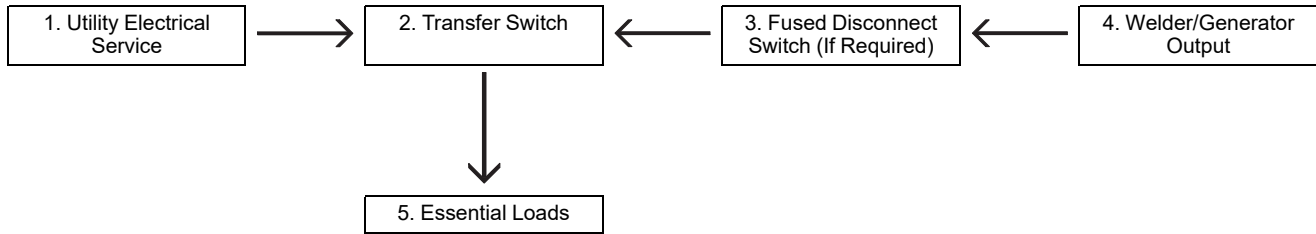

- ⚠ Have only qualified persons perform these connections according to all applicable codes and safety practices.**
- ⚠ Properly install, ground, and operate this equipment according to its Owner's Manual and national, state, and local codes.**
- ⚠ Do not connect to any electrical distribution system normally supplied by utility power unless a proper transfer switch and grounding procedure are employed.**

*☞ Customer-supplied equipment is required if generator will supply standby power during emergencies or power outages.*

- 1 Utility Electrical Service
- 2 Transfer Switch (Double-Throw)

Switch transfers the electrical load from electric utility service to the generator. Transfer load back to electric utility when service is restored.

Install correct switch (customer-supplied). Switch rating must be same as or greater than the branch overcurrent protection.

- 3 Fused Disconnect Switch

Install correct switch (customer-supplied) if required by electrical code.

- 4 Welder/Generator Output

Generator output voltage and wiring must be consistent with regular (utility) system voltage and wiring.

Connect generator with temporary or permanent wiring suitable for the installation.

Turn off or unplug all equipment connected to generator before starting or stopping engine. When starting or stopping, the engine has low speed which causes low voltage and frequency.

- 5 Essential Loads

Generator output may not meet the electrical requirements of the premises. If generator does not produce enough output to meet all requirements, connect only essential loads. See Section 11-3.

## 11-10. Selecting Extension Cord (Use Shortest Cord Possible)

### A. Cord Lengths For 120 Volt Loads



**⚠ Use GFCI protection when operating auxiliary equipment. If unit does not have GFCI receptacles, use GFCI-protected extension cord. Do not use GFCI receptacles to power life support equipment.**

Current (Amperes)	Load (Watts)	Maximum Allowable Cord Length In ft (m) for Conductor Size In AWG (mm <sup>2</sup> )*					
		4 (25)	6 (16)	8 (10)	10 (6)	12 (4)	14 (2.5)
5	600			350 (106)	225 (68)	137 (42)	100 (30)
7	840		400 (122)	250 (76)	150 (46)	100 (30)	62 (19)
10	1200	400 (122)	275 (84)	175 (53)	112 (34)	62 (19)	50 (15)
15	1800	300 (91)	175 (53)	112 (34)	75 (23)	37 (11)	30 (9)
20	2400	225 (68)	137 (42)	87 (26)	50 (15)	30 (9)	
25	3000	175 (53)	112 (34)	62 (19)	37 (11)		
30	3600	150 (46)	87 (26)	50 (15)	37 (11)		
35	4200	125 (38)	75 (23)	50 (15)			
40	4800	112 (34)	62 (19)	37 (11)			
45	5400	100 (30)	62 (19)				
50	6000	87 (26)	50 (15)				

\*Conductor size is based on maximum 2% voltage drop.

## B. Cord Lengths For 240 Volt Loads



**⚠ Use GFCI protection when operating auxiliary equipment. If unit does not have GFCI receptacles, use GFCI-protected extension cord. Do not use GFCI receptacles to power life support equipment.**

		Maximum Allowable Cord Length In ft (m) for Conductor Size In AWG (mm <sup>2</sup> )*					
Current (Amperes)	Load (Watts)	4 (25)	6 (16)	8 (10)	10 (6)	12 (4)	14 (2.5)
5	1200			700 (213)	450 (137)	225 (84)	200 (61)
7	1680		800 (244)	500 (152)	300 (91)	200 (61)	125 (38)
10	2400	800 (244)	550 (168)	350 (107)	225 (69)	125 (38)	100 (31)
15	3600	600 (183)	350 (107)	225 (69)	150 (46)	75 (23)	60 (18)
20	4800	450 (137)	275 (84)	175 (53)	100 (31)	60 (18)	
25	6000	350 (107)	225 (69)	125 (38)	75 (23)		
30	7000	300 (91)	175 (53)	100 (31)	75 (23)		
35	8400	250 (76)	150 (46)	100 (31)			
40	9600	225 (69)	125 (38)	75 (23)			
45	10,800	200 (61)	125 (38)				
50	12,000	175 (53)	100 (31)				

\*Conductor size is based on maximum 2% voltage drop.

# SECTION 12 – STICK WELDING (SMAW) GUIDELINES

## 12-1. Stick Welding Procedure

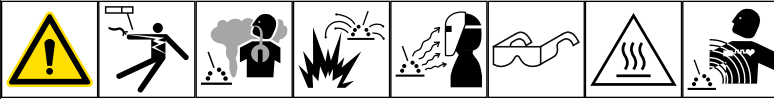

### Tools Needed:

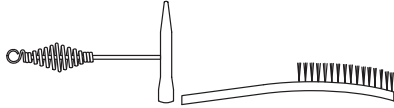

### Equipment Needed:

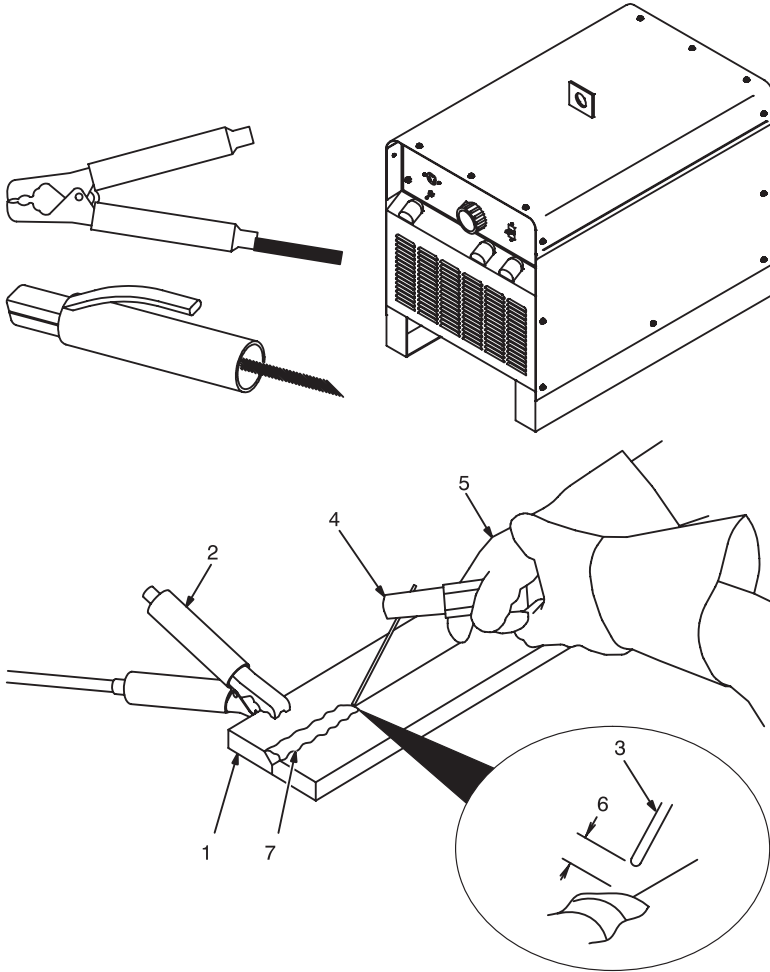

 **Weld current starts when electrode touches workpiece.**

 **Weld current can damage electronic parts in vehicles. Disconnect both battery cables before welding on a vehicle. Place work clamp as close to the weld as possible.**

 *Always wear appropriate personal protective clothing.*

1 Workpiece

Make sure workpiece is clean before welding.

2 Work Clamp

Place as close to the weld as possible.

3 Electrode

Before striking an arc, insert an electrode in the electrode holder. A small diameter electrode requires less current than a large one. Follow recommendations of the electrode manufacturer when setting weld amperage (see Section 12-2).

4 Insulated Electrode Holder

5 Electrode Holder Position

6 Arc Length

Arc length is the distance from the electrode to the workpiece. A short arc with correct amperage will give a sharp, crackling sound. Correct arc length is related to electrode diameter. Examine the weld bead to determine if the arc length is correct.

Arc length for 1/16 and 3/32 in. diameter electrodes should be about 1/16 in. (1.6 mm); arc length for 1/8 and 5/32 in. electrodes should be about 1/8 in. (3 mm).

7 Slag

Use a chipping hammer and wire brush to remove slag. Remove slag and check weld bead before making another weld pass.

## 12-2. Electrode And Amperage Selection Chart

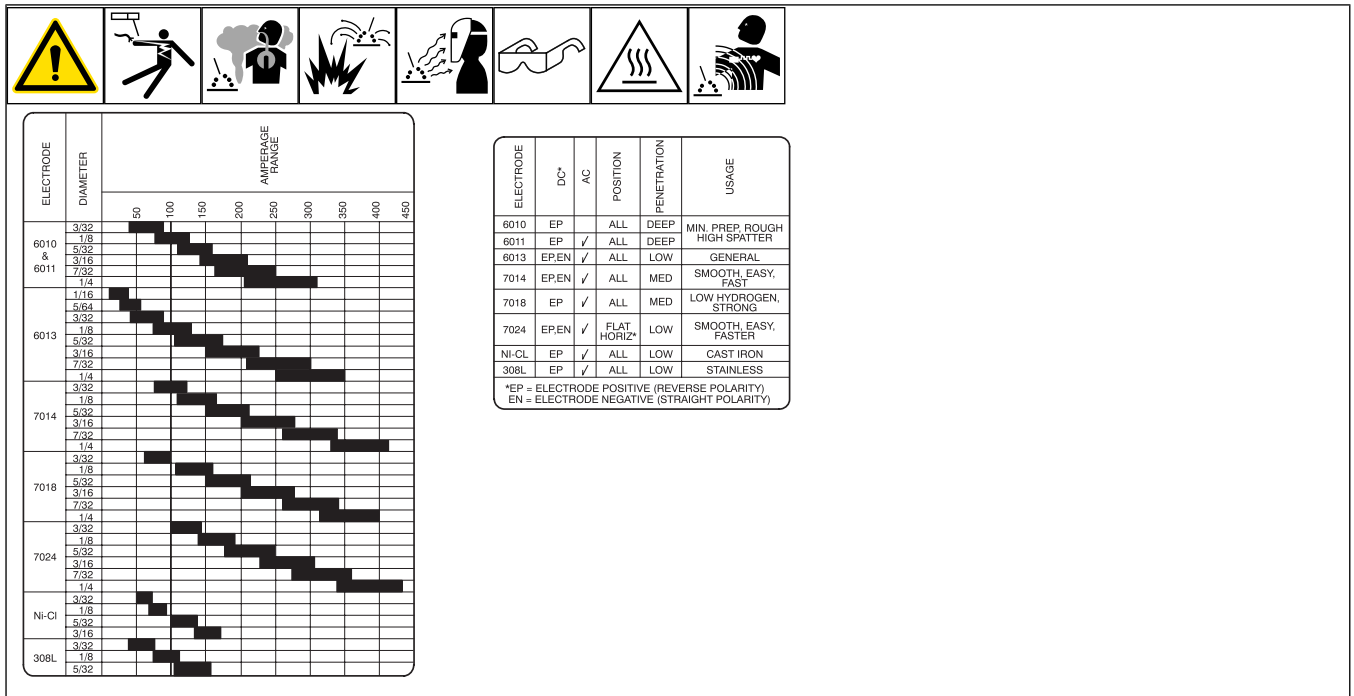

## 12-3. Striking An Arc

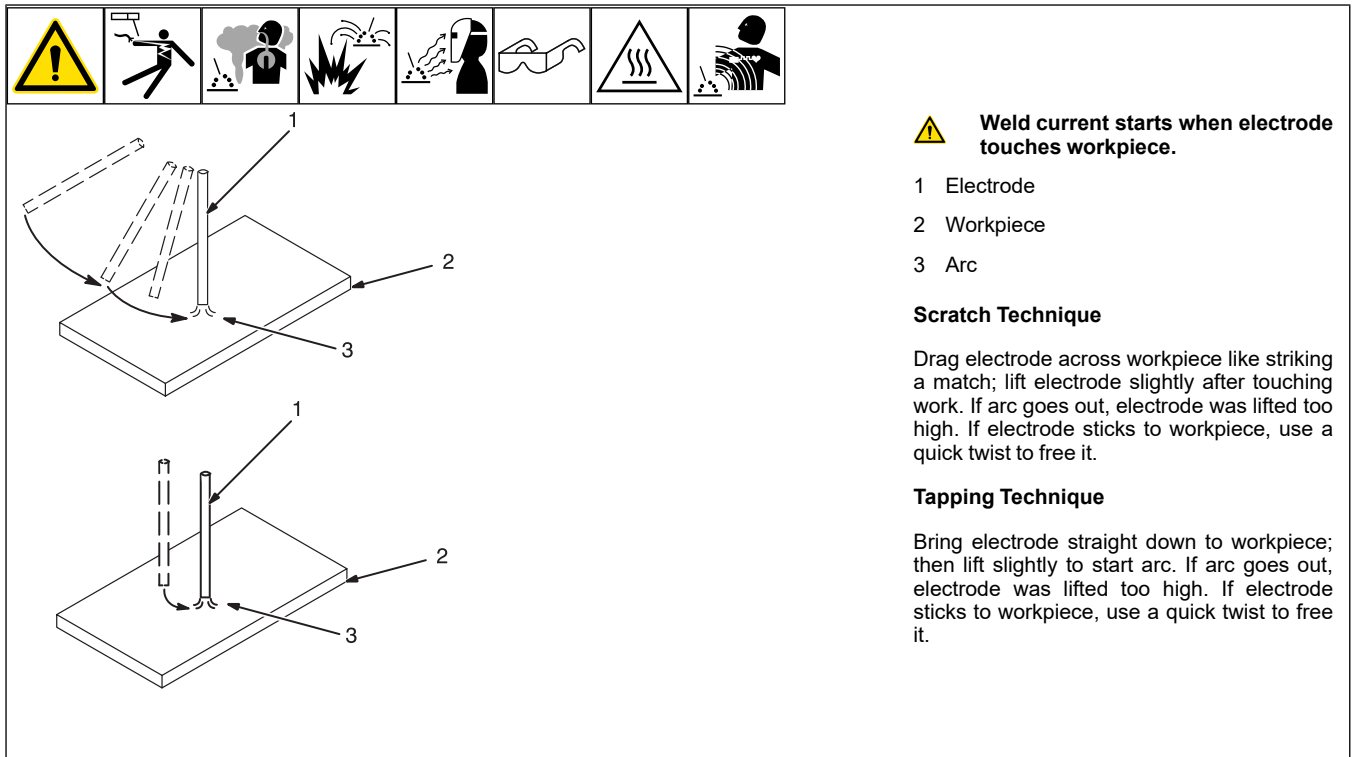

## 12-4. Positioning Electrode Holder

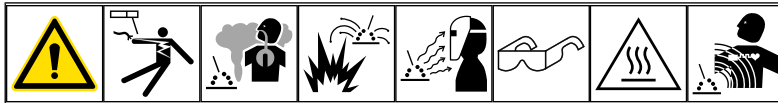

### Groove Welds

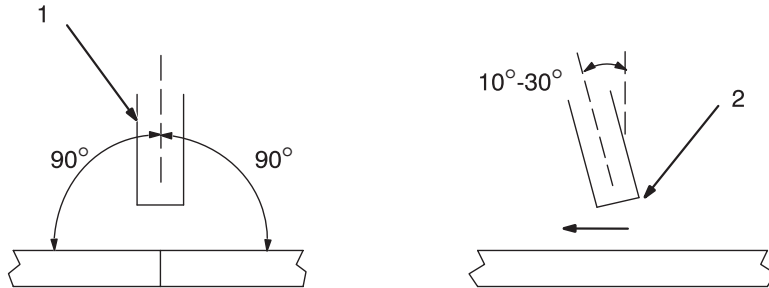

### Fillet Welds

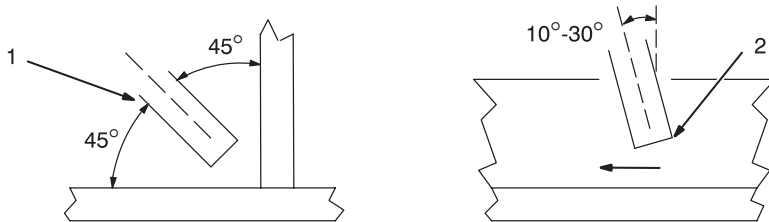

- 1 End View Of Work Angle
- 2 Side View Of Electrode Angle

After learning to start and hold an arc, practice running beads of weld metal on flat plates using a full electrode.

Hold the electrode nearly perpendicular to the work, although tilting it ahead (in the direction of travel) will be helpful.

*To produce the best results, hold a short arc, travel at a uniform speed, and feed the electrode downward at a constant rate as it melts.*

## 12-5. Poor Weld Bead Characteristics

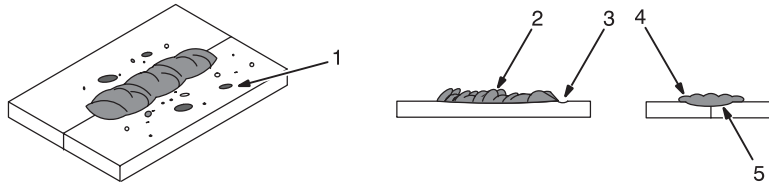
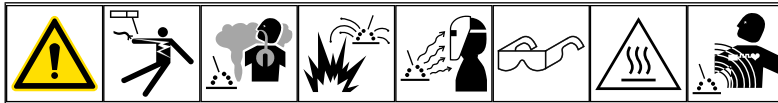

- 1 Large Spatter Deposits
- 2 Rough, Uneven Bead
- 3 Slight Crater During Welding
- 4 Bad Overlap
- 5 Poor Penetration

## 12-6. Good Weld Bead Characteristics

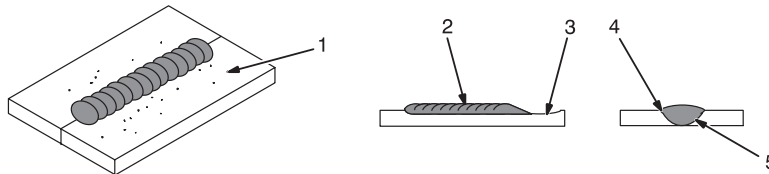
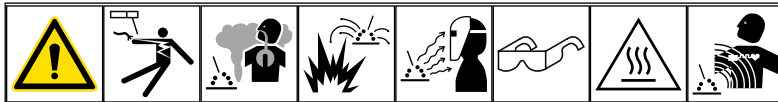

- 1 Fine Spatter
- 2 Uniform Bead
- 3 Moderate Crater During Welding

Weld a new bead or layer for each 1/8 in. (3.2 mm) thickness in metals being welded.

- 4 No Overlap
- 5 Good Penetration into Base Metal

## 12-7. Conditions That Affect Weld Bead Shape

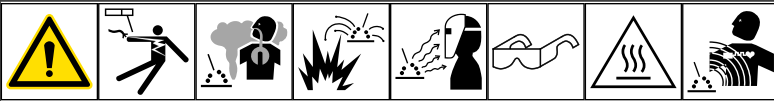

### Electrode Angle

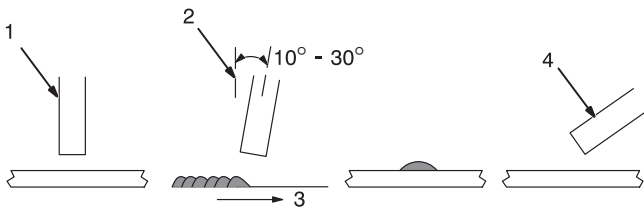

☞ *Weld bead shape is affected by electrode angle, arc length, travel speed, and thickness of base metal.*

- 1 Angle Too Small
- 2 Correct Angle
- 3 Drag
- 4 Angle Too Large
- 5 Too Short
- 6 Normal
- 7 Too Long
- 8 Spatter
- 9 Slow
- 10 Normal
- 11 Fast

### Arc Length

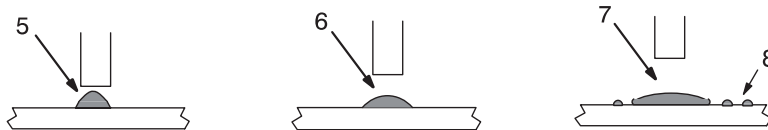

### Travel Speed

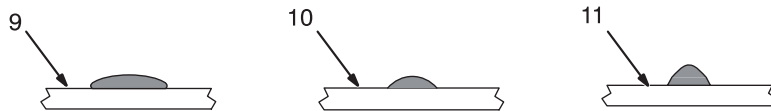

## 12-8. Electrode Movement During Welding

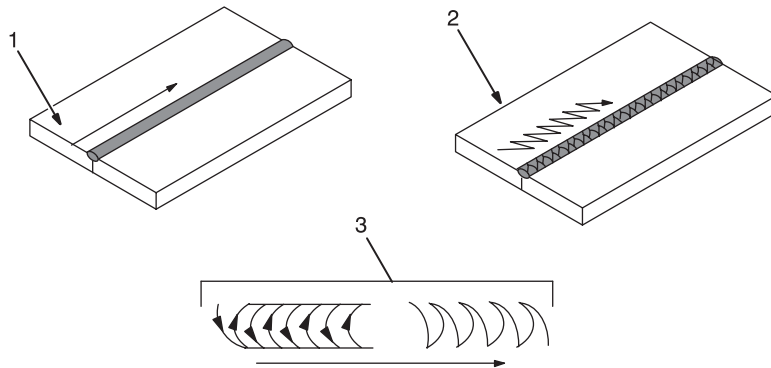

☞ *Normally, a single stringer bead is satisfactory for most narrow groove weld joints; however, for wide groove weld joints or bridging across gaps, a weave bead or multiple stringer beads works better.*

- 1 Stringer Bead - Steady Movement Along Seam
- 2 Weave Bead - Side To Side Movement Along Seam
- 3 Weave Patterns

Use weave patterns to cover a wide area in one pass of the electrode. Do not let weave width exceed 2-1/2 times diameter of electrode.

## 12-9. Welding Lap Joints

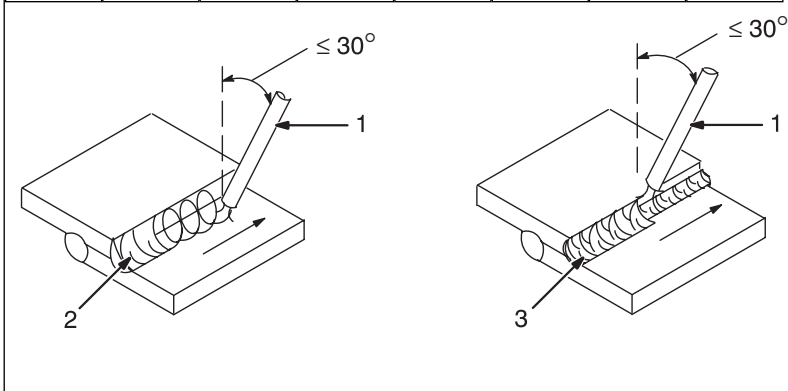

- 1 Electrode
- 2 Single-Layer Fillet Weld

Move electrode in circular motion.

- 3 Multi-Layer Fillet Weld

Weld a second layer when a heavier fillet is needed. Remove slag before making another weld pass. Weld both sides of joint for maximum strength.

## 12-10. Welding Groove (Butt) Joints

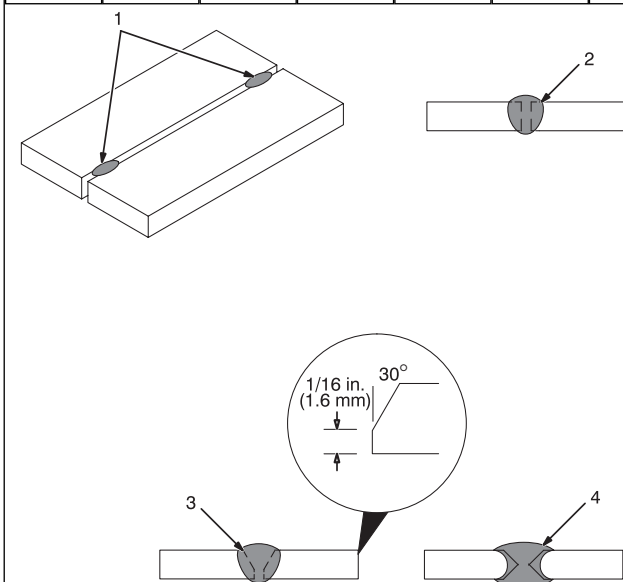

- 1 Tack Welds

Prevent butt joint distortion by tack welding the materials in position before final weld.

Workpiece distortion occurs when heat is applied locally to a joint. One side of a metal plate will curl up toward the weld. Distortion will also cause the edges of a butt joint to pull together ahead of the electrode as the weld cools.

- 2 Square Groove Weld
- 3 Single V-Groove Weld
- 4 Double V-Groove Weld

Materials up to 3/16 in. (5 mm) thick can often be welded without special preparation using the square groove weld. However, when welding thicker materials it may be necessary to prepare the edges (V-groove) of butt joints to ensure good welds.

The single or double V-groove weld is good for materials 3/16 - 3/4 in. (5-19 mm) thick. Generally, the single V-groove is used on materials up to 3/4 in. (19 mm) thick and when, regardless of thickness, you can weld from one side only. Create a 30 degree bevel with oxyacetylene or plasma cutting equipment. Remove scale from material after cutting. A grinder can also be used to prepare bevels.

## 12-11. Welding T-Joints

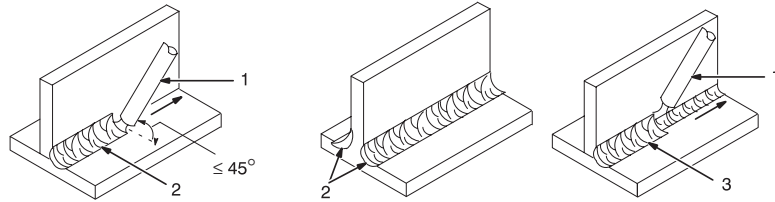
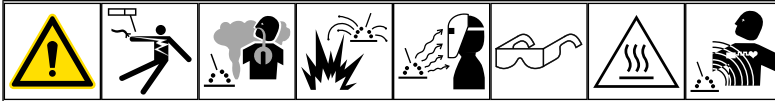

- 1 Electrode
- 2 Fillet Weld

Keep arc short and move at definite rate of speed. Hold electrode as shown to provide fusion into the corner. Square edge of the weld surface.

For maximum strength weld both sides of upright section.

- 3 Multi-Layer Deposits

Weld a second layer when a heavier fillet is needed. Use any of the weaving patterns shown in Section 12-8. Remove slag before making another weld pass.

## 12-12. Weld Test

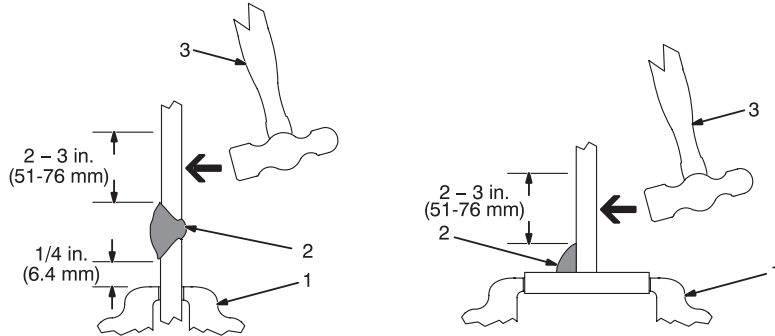
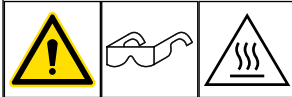

- 1 Vise
- 2 Weld Joint
- 3 Hammer

Strike the weld joint in the direction shown. A good weld bends over but does not break.

If the weld breaks, examine it to determine the cause.

If the weld is porous (many holes), the arc length was probably too long.

If the weld contains bits of slag, the arc may have been too long or the electrode was moved incorrectly which allowed molten slag to be trapped in the weld. This may happen on a V-groove joint made in several layers and calls for additional cleaning between layers.

If the original beveled surface is visible the material was not fully melted which is often caused by insufficient heat or too fast a travel speed.

## 12-13. Troubleshooting

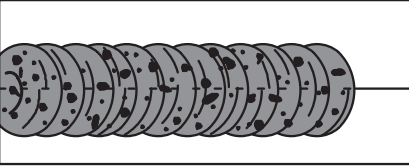
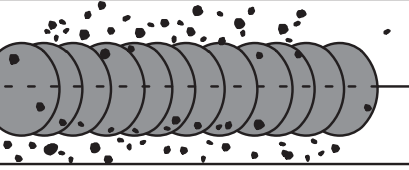
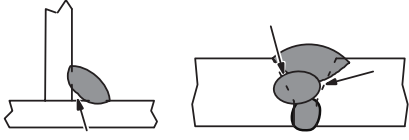
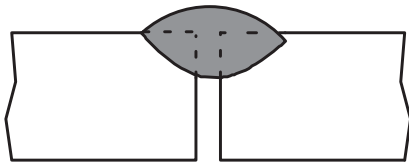
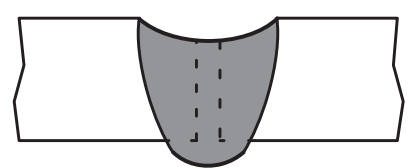
	<p>Porosity - small cavities or holes resulting from gas pockets in weld metal.</p>
<p><b>Possible Causes</b></p>	<p><b>Corrective Actions</b></p>
<p>Arc length too long.</p>	<p>Reduce arc length.</p>
<p>Damp electrode.</p>	<p>Use dry electrode.</p>
<p>Workpiece dirty.</p>	<p>Remove all grease, oil, moisture, rust, paint, coatings, slag, and dirt from work surface before welding.</p>
	<p>Excessive Spatter - scattering of molten metal particles that cool to solid form near weld bead.</p>
<p><b>Possible Causes</b></p>	<p><b>Corrective Actions</b></p>
<p>Amperage too high for electrode.</p>	<p>Decrease amperage or select larger electrode.</p>
<p>Arc length too long or voltage too high.</p>	<p>Reduce arc length or voltage.</p>
	<p>Incomplete Fusion - failure of weld metal to fuse completely with base metal or a preceding weld bead.</p>
<p><b>Possible Causes</b></p>	<p><b>Corrective Actions</b></p>
<p>Insufficient heat input.</p>	<p>Increase amperage. Select larger electrode and increase amperage.</p>
<p>Improper welding technique.</p>	<p>Place stringer bead in proper location(s) at joint during welding. Adjust work angle or widen groove to access bottom during welding. Momentarily hold arc on groove side walls when using weaving technique. Keep arc on leading edge of weld puddle.</p>
<p>Workpiece dirty.</p>	<p>Remove all grease, oil, moisture, rust, paint, coatings, slag, and dirt from work surface before welding.</p>
	<p>Lack Of Penetration - shallow fusion between weld metal and base metal.</p>
<p><b>Possible Causes</b></p>	<p><b>Corrective Actions</b></p>
<p>Improper joint preparation.</p>	<p>Material too thick. Joint preparation and design must provide access to bottom of groove.</p>
<p>Improper weld technique.</p>	<p>Keep arc on leading edge of weld puddle.</p>
<p>Insufficient heat input.</p>	<p>Increase amperage. Select larger electrode and increase amperage. Reduce travel speed.</p>
	<p>Excessive Penetration - weld metal melting through base metal and hanging underneath weld.</p>
<p><b>Possible Causes</b></p>	<p><b>Corrective Actions</b></p>
<p>Excessive heat input.</p>	<p>Select lower amperage. Use smaller electrode. Increase and/or maintain steady travel speed.</p>

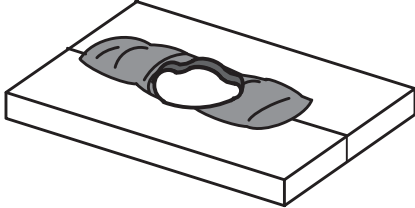
	<p>Burn-Through - weld metal melting completely through base metal resulting in holes where no metal remains.</p>
<p><b>Possible Causes</b></p>	<p><b>Corrective Actions</b></p>
<p>Excessive heat input.</p>	<p>Select lower amperage. Use smaller electrode. Increase and/or maintain steady travel speed.</p>

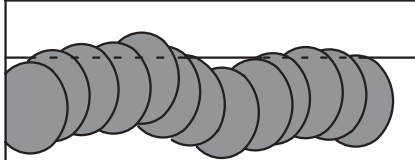
	<p>Waviness Of Bead - weld metal that is not parallel and does not cover joint formed by base metal.</p>
<p><b>Possible Causes</b></p>	<p><b>Corrective Actions</b></p>
<p>Unsteady hand.</p>	<p>Use two hands. Practice technique.</p>

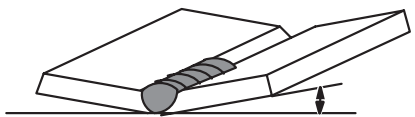
	<p>Distortion - contraction of weld metal during welding that forces base metal to move. Illustration: Base metal moves in the direction of the weld bead.</p>
<p><b>Possible Causes</b></p>	<p><b>Corrective Actions</b></p>
<p>Excessive heat input.</p>	<p>Use restraint (clamp) to hold base metal in position. Make tack welds along joint before starting welding operation. Select lower amperage for electrode. Increase travel speed. Weld in small segments and allow cooling between welds.</p>

# 5/3/1 WARRANTY



Effective January 1, 2024

5/3/1 WARRANTY applies to all Hobart welding equipment, plasma cutters and spot welders with a serial number preface of NE or newer.

This limited warranty supersedes all previous Hobart warranties and is exclusive with no other guarantees or warranties expressed or implied.

Hobart products are serviced by Hobart or Miller Authorized Service Agencies.

LIMITED WARRANTY - Subject to the terms and conditions below, Miller Electric Mfg. LLC, dba Hobart Welding Products, Appleton, Wisconsin, warrants to its original retail purchaser that new Hobart equipment sold after the effective date of this limited warranty is free of defects in material and workmanship at the time it is shipped. THIS WARRANTY IS EXPRESSLY IN LIEU OF ALL OTHER WARRANTIES, EXPRESS OR IMPLIED, INCLUDING THE WARRANTIES OF MERCHANTABILITY AND FITNESS.

Within the warranty periods listed below, Hobart/Miller will repair or replace any warranted parts or components that fail due to such defects in material or workmanship. Notifications submitted as online warranty claims must provide detailed descriptions of the fault and troubleshooting steps taken to diagnose failed parts. Warranty claims that lack the required information as defined in the Miller Service Operation Guide (SOG) may be denied by Miller.

Hobart/Miller shall honor warranty claims on warranted equipment listed below in the event of a defect within the warranty coverage time periods listed below. Warranty time periods start on the delivery date of the equipment to the original retail purchaser.

#### 1 5 Years — Parts and Labor

- Original Main Power Rectifiers only to include SCRs, diodes, and discrete rectifier modules in non-inverter products
- Capacitors
- Reactors
- Stabilizers
- Transformers

#### 2 3 Years — Parts and Labor Unless Specified

- Drive Systems
- Idle Module
- Inverter Power Sources
- PC Boards
- Rotors, Stators and Brushes
- Solenoid Valves
- Switches and Controls
- Transformer/Rectifier Power Sources

#### 3 1 Year — Parts and Labor Unless Specified(90 days for industrial use)

- Accessories (Kits)

- MIG Flowgauge Regulators (No Labor)
- MIG Guns/TIG Torches
- Plasma Cutting Torches
- Remote Controls
- Replacement Parts (No labor) - 90 days
- Running Gear
- Spoolguns

#### 4 6 Months — Parts

- 12 Volt Automotive-Style Batteries

#### 5 Engines and tires are warranted separately by the manufacturer.

Hobart's 5/3/1 Limited Warranty shall not apply to:

1. **Consumable components; such as contact tips, cutting nozzles, contactors, brushes, relays, work station table tops and welding curtains, or parts that fail due to normal wear. (Exception: brushes and relays are covered on all engine-driven products.)**
2. Items furnished by Hobart/Miller, but manufactured by others, such as engines or trade accessories. These items are covered by the manufacturer's warranty, if any.
3. Equipment that has been modified by any party other than Hobart/Miller, or equipment that has been improperly installed, improperly operated or misused based upon industry standards, or equipment which has not had reasonable and necessary maintenance, or equipment which has been used for operation outside of the specifications for the equipment.
4. Defects caused by accident, unauthorized repair, or improper testing.

HOBART PRODUCTS ARE INTENDED FOR COMMERCIAL AND INDUSTRIAL USERS TRAINED AND EXPERIENCED IN THE USE AND MAINTENANCE OF WELDING EQUIPMENT.

The exclusive remedies for warranty claims are, at Hobart's/Miller's option, either: (1) repair; or (2) replacement; or, if approved in writing by Hobart/Miller, (3) the pre-approved cost of repair or replacement at an authorized Hobart/Miller service station; or (4) payment of or credit for the purchase price (less reasonable depreciation based upon use). Products may not be returned without Hobart's/Miller's written approval. Return shipment shall be at customer's risk and expense.

The above remedies are F.O.B. Appleton, WI, or Hobart's/Miller's authorized service facility. Transportation and freight are the customer's responsibility. TO THE EXTENT PERMITTED BY LAW, THE REMEDIES HEREIN ARE THE SOLE AND EXCLUSIVE REMEDIES REGARDLESS OF THE LEGAL THEORY. IN NO EVENT SHALL HOBART/MILLER BE LIABLE FOR DIRECT, INDIRECT, SPECIAL, INCIDENTAL OR CONSEQUENTIAL DAMAGES (INCLUDING LOSS OF PROFIT) REGARDLESS OF THE LEGAL THEORY. ANY WARRANTY NOT PROVIDED HEREIN AND ANY IMPLIED WARRANTY, GUARANTY, OR REPRESENTATION, INCLUDING ANY IMPLIED WARRANTY OF MERCHANTABILITY OR FITNESS FOR PARTICULAR PURPOSE, ARE EXCLUDED AND DISCLAIMED BY HOBART/MILLER.

Some US states do not allow limiting the duration of an implied warranty or the exclusion of certain damages, so the above limitations may not apply to you. This warranty provides specific legal rights, and other rights may be available depending on your state. In Canada, some provinces provide additional warranties or remedies, and to the extent the law prohibits their waiver, the limitations set out above may not apply. This Limited Warranty provides specific legal rights, and other rights may be available, but may vary by province.

## Warranty Questions?

Call 1-800-332-3281  
8 AM – 5 PM EST

### Service

You always get the fast, reliable response you need. Most replacement parts can be processed and shipped in 24 hours.

### Support

Need fast answers to the tough welding questions? Contact your distributor or call 1-800-332-3281. The expertise of the distributor and Hobart is there to help you, every step of the way.

### Assistance

Visit the Hobart website:  
[www.HobartWelders.com](http://www.HobartWelders.com)

# Owner's Record

Please complete and retain with your personal records.

Model Name \_\_\_\_\_ Serial/Style Number \_\_\_\_\_

Purchase Date \_\_\_\_\_ (Date which equipment was delivered to original customer.) \_\_\_\_\_

Distributor \_\_\_\_\_

Address \_\_\_\_\_

City \_\_\_\_\_

State \_\_\_\_\_ Zip \_\_\_\_\_



Thank you for purchasing Hobart. Our trained technical support team is dedicated to your satisfaction. For questions regarding performance, operation, or service, contact us!

## Resources Available

Always provide Model Name and Serial/Style Number.

### To locate a Service Center:

Call 1-800-332-3281

or visit our website at [www.HobartWelders.com/wheretobuy](http://www.HobartWelders.com/wheretobuy)

### For Technical Assistance:

Call 1-800-332-3281

8 AM to 5 PM EST – Monday through Friday

### Miller Electric Mfg. LLC

An Illinois Tool Works Company  
1635 West Spencer Street  
Appleton, WI 54914 USA

For Assistance:  
Call 1-800-332-3281

