



6 GAL. PANCAKE AIR COMPRESSOR

Owner's Manual



! WARNING: Read carefully and understand all ASSEMBLY AND OPERATION INSTRUCTIONS before operating. Failure to follow the safety rules and other basic safety precautions may result in serious personal injury.

Item #115067

READ & SAVE THESE INSTRUCTIONS

Thank you very much for choosing a **IRONTON** product!

For future reference, please complete the owner's record below:

Serial Number/Lot Date Code: _____

Purchase Date: _____

Save the receipt, warranty, and this manual. It is important that you read the entire manual to become familiar with this product before you begin using it.

This product is designed for certain applications only. Northern Tool & Equipment is not responsible for issues arising from modification or improper use of this product such as an application for which it was not designed. We strongly recommend that this product not be modified and/or used for any application other than that for which it was designed.

For technical questions, please call **1-800-222-5381**.

Table of Contents

Intended Use.....	4
Packaging Contents.....	4
Technical Specifications	4
Important Safety Information	4
Specific Operation Warnings	7
Grounding	9
Extension Cords.....	10
Main Parts of Product.....	11
Assembly Instructions.....	12
Before Each Use.....	13
Operating Instructions.....	13
After Each Use.....	14
Maintenance	15
Troubleshooting	16
Parts Diagram	18
Parts List	19
Replacement Parts	20
Limited Warranty	21

Intended Use

The portable air compressor has a long-life oil-free, maintenance-free pump for convenient use.

Packaging Contents

- Air Compressor (1)
- Manual (1)

Technical Specifications

Property	Specification
Electrical Rating	120VAC / 60Hz / 11.5A
Air Outlet Size	1/4" NPT
Air Pressure	150 PSI
Air Tank Capacity	6 Gallons
Air Flow Capacity	3.6 SCFM @ 40 PSI; 2.6 CFM @ 90 PSI
Sound Level	86 dB

Important Safety Information

⚠WARNING

- Read and understand all instructions. Failure to follow all instructions may result in serious injury or property damage.
- The warnings, cautions, and instructions in this manual cannot cover all possible conditions or situations that could occur. Exercise common sense and caution when using this tool. Always be aware of the environment and ensure that the tool is used in a safe and responsible manner.
- Do not allow persons to operate or assemble the product until they have read this manual and have developed a thorough understanding of how it works.
- Do not modify this product in any way. Unauthorized modification may impair the function and/or safety and could affect the life of the product. There are specific applications for which the product was designed.
- Use the right tool for the job. DO NOT attempt to force small equipment to do the work of larger industrial equipment. There are certain applications for which this equipment was designed. It will be a safer experience and do the job better at the capacity for which it was intended. DO NOT use this equipment for a purpose for which it was not intended.
- Industrial or commercial applications must follow OSHA requirements.

⚠️WARNING

- This product may contain chemicals known to the state of California to cause cancer, birth defects, or other reproductive harm.
- Some dust created by power sanding, sawing, grinding, drilling, and other construction activities contains chemicals known to the state of California to cause cancer, birth defects, or other reproductive harm. Some examples of these chemicals are:
 - - lead from lead-based paints,
 - - crystalline silica from bricks and cement and other masonry products, and
 - - arsenic and chromium from chemically-treated lumber.
- Your risk from these exposures varies, depending on how often you do this type of work. To reduce your exposure to these chemicals: work in a well-ventilated area, and work with approved safety equipment, such as dust masks that are specially designed to filter out microscopic particles.
- Handling power cords on corded products may expose you to lead, a chemical known to the state of California to cause cancer and birth defects or other reproductive harm. Wash your hands after handling.

⚠️WARNING

WORK AREA SAFETY

- Inspect the work area before each use. Keep work area clean, dry, free of clutter, and well-lit. Cluttered, wet, or dark work areas can result in injury. Using the product in confined work areas may put you dangerously close to cutting tools and rotating parts.
- Do not use the product where there is a risk of causing a fire or an explosion; e.g., in the presence of flammable liquids, gases, or dust. The product can create sparks, which may ignite the flammable liquids, gases, or dust.
- Do not allow the product to come into contact with an electrical source. The tool is not insulated and contact will cause electrical shock.
- Keep children and bystanders away from the work area while operating the tool. Do not allow children to handle the product.
- Be aware of all power lines, electrical circuits, water pipes, and other mechanical hazards in your work area. Some of these hazards may be hidden from your view and may cause personal injury and/or property damage if contacted.

⚠WARNING

PERSONAL SAFETY

- Stay alert, watch what you are doing, and use common sense when operating the tool. Do not use the tool while you are tired or under the influence of drugs, alcohol, or medication. A moment of inattention while operating the tool may result in serious personal injury.
- Dress properly. Do not wear loose clothing, dangling objects, or jewelry. Keep your hair, clothing and gloves away from moving parts. Loose clothes, jewelry, or long hair can be caught in moving parts. Air vents on the tool often cover moving parts and should be avoided.
- Wear the proper personal protective equipment when necessary. Use ANSI Z87.1 compliant safety goggles (not safety glasses) with side shields, or when needed, a face shield. Use a dust mask in dusty work conditions. Also use non-skid safety shoes, hardhat, gloves, dust collection systems, and hearing protection when appropriate. This applies to all persons in the work area.
- Do not overreach. Keep proper footing and balance at all times.

⚠CAUTION

PRODUCT USE AND CARE

- Do not force the product. Products are safer and do a better job when used in the manner for which they are designed. Plan your work, and use the correct product for the job.
- Check for damaged parts before each use. Carefully check that the product will operate properly and perform its intended function. Replace damaged or worn parts immediately. Never operate the product with a damaged part.
- Store the product when it is not in use. Store it in a dry, secure place out of the reach of children. Inspect the tool for good working condition prior to storage and before re-use.
- Use only accessories that are recommended by the manufacturer for use with your product. Accessories that may be suitable for one product may create a risk of injury when used with another tool. Never use an accessory that has a lower operating speed or operating pressure than the tool itself.
- Keep guards in place and in working order. Never operate the product without the guards in place.

Specific Operation Warnings

⚠WARNING

Work area safety

- Keep work area clean and well lit. Cluttered or dark areas invite accidents.
- Do not operate the compressor in explosive atmospheres, such as in the presence of flammable liquids, gases or dust. Compressor motors produce sparks which may ignite the dust or fumes.
- Keep children and bystanders away from an operating compressor

Electrical safety

- Compressor plugs must match the outlet. never modify the plug in any way. Do not use any adapter plugs with grounded compressors. Standard plugs and matching outlets will reduce risk of electric shock.
- Do not expose compressor to rain or wet conditions. Water entering a compressor will increase the risk of electric shock.
- Do not abuse the cord. never use the cord for unplugging the compressor. Keep cord away from heat, oil, sharp edges or moving parts. Damaged or entangled cords increase the risk of electric shock.

Personal safety

- Stay alert, watch what you are doing and use common sense when operating this compressor. Do not use this compressor while you are tired or under the influence of drugs, alcohol or medication. A moment of inattention while operating a compressor may result in serious personal injury.
- Use personal protective equipment. always wear ANSI-approved eye protection during setup and use.
- Prevent unintentional starting. ensure the switch is in the off-position before connecting to power source or moving the compressor.

Compressor use and care

- Do not use the compressor if the switch does not turn it on and off. Any compressor that cannot be controlled with the switch is dangerous and must be repaired.
- Disconnect the plug from the power source before making any adjustments, changing accessories, or storing the compressor. Such preventive safety measures reduce the risk of starting the compressor accidentally.
- Store an idle compressor out of the reach of children and do not allow persons unfamiliar with the compressor or these instructions to operate it. A compressor is dangerous in the hands of untrained users.
- Maintain the compressor. Keep the compressor clean for better and safer performance. Follow instructions for lubricating and changing accessories.
- Keep dry, clean and free from oil and grease. check for misalignment or binding of moving parts, breakage of parts and any other condition that may affect the compressor's operation. if damaged, have the compressor repaired before use. Many accidents are caused by a poorly maintained compressor.
- Use the compressor in accordance with these instructions, taking into account the working conditions and the work to be performed. Use of the compressor for operations different from those intended could result in a hazardous situation.

⚠WARNING

Service

- Have your compressor serviced by a qualified repair person using only identical replacement parts. This will ensure that the safety of the compressor is maintained.

Grounding

⚠WARNING

- This machine must be grounded while in use to protect the operator from electrical shock. This unit is equipped with an electrical cord that has an equipment grounding conductor and a grounding plug. The plug **MUST** be plugged into a matching receptacle that is properly installed and grounded in accordance with ALL local codes and ordinances.
- **DO NOT MODIFY THE PROVIDED PLUG.** If it will not fit the receptacle, have the proper receptacle installed by a qualified electrician.

CHECK with a qualified electrician or service person if you do not completely understand the grounding instructions, or if you are not sure the tool is properly grounded.

Grounded Tools: Tools with 3-Prong Plugs

Tools marked **Grounding Required** have a 3-wire cord and 3-prong grounding plug. The plug must be connected to a properly grounded outlet. If the tool should electrically malfunction or break down, grounding provides a low resistance path to carry electricity away from the user, reducing the risk of electric shock. (See Figure A.)

The grounding prong in the plug is connected through the green wire inside the cord to the grounding system in the tool. The green wire in the cord must be the only wire connected to the tool's grounding system and must never be attached to an electrically live terminal.

Your tool must be plugged into an appropriate outlet, properly installed and grounded in accordance with all codes and ordinances. The plug and outlet should look like those in the following illustration.

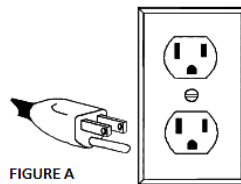

FIGURE A

Double Insulated Tools: Tools with Two-Prong Plugs

Tools marked **Double Insulated** do not require grounding. They have a special double insulation system which satisfies OSHA requirements and complies with the applicable standards of Underwriters Laboratories, Inc., the Canadian Standard Association, and the National Electrical Code. (See Figure B.)

Double insulated tools may be used in either of the 120 volt outlets shown in the following illustration.

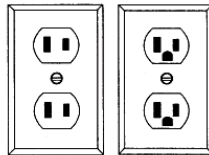

FIGURE B

Extension Cords

⚠WARNING

- **USE A PROPER EXTENSION CORD.** Make sure your extension cord is in good condition. When using an extension cord, be sure to use one heavy enough to carry the current your product will draw. An undersized cord will cause a drop in line voltage, resulting in loss of power and cause overheating.
- Be sure your extension cord is properly wired and in good condition. Always replace a damaged extension cord or have it repaired by a qualified person before using it. Protect your extension cords from sharp objects, excessive heat and damp or wet areas.
- Grounded tools require a 3-wire extension cord. Double Insulated tools can use either a 2- or 3-wire extension cord.
- As the distance from the supply outlet increases, you must use a heavier gauge extension cord. Using extension cords with inadequately sized wire causes a serious drop in voltage, resulting in loss of power and possible tool damage.
- The smaller the wire's gauge number, the greater the capacity of the cord. For example, a 14-gauge cord can carry a higher current than a 16-gauge cord. Minimum extension cord wire size is shown in the following table:

Minimum Wire Size Of Extension Cords				
Nameplate AMPS	Cord Length			
	25'	50'	100'	150'
0-6	18 AWG	16 AWG	16 AWG	14 AWG
6-10	18 AWG	16 AWG	14 AWG	12 AWG
10-12	16 AWG	16 AWG	14 AWG	12 AWG
12-16	14 AWG	12 AWG	NOT RECOMMENDED	

- When using more than one extension cord to make up the total length, make sure each cord contains at least the minimum wire size required.
- If you are using one extension cord for more than one tool, add the nameplate amperes and use the sum to determine the required minimum cord size.
- If you are using an extension cord outdoors, make sure it is marked with the suffix **W-A** (**W** in Canada) to indicate it is acceptable for outdoor use.
- Make sure your extension cord is properly wired and in good electrical condition. Always replace a damaged extension cord or have it repaired by a qualified electrician before using it.
- Protect your extension cords from sharp objects, excessive heat, and damp or wet areas.

Main Parts of Product

Subassembly
Tank Gauge
Outlet Gauge
Safety Valve
Drain Valve
Air Outlets

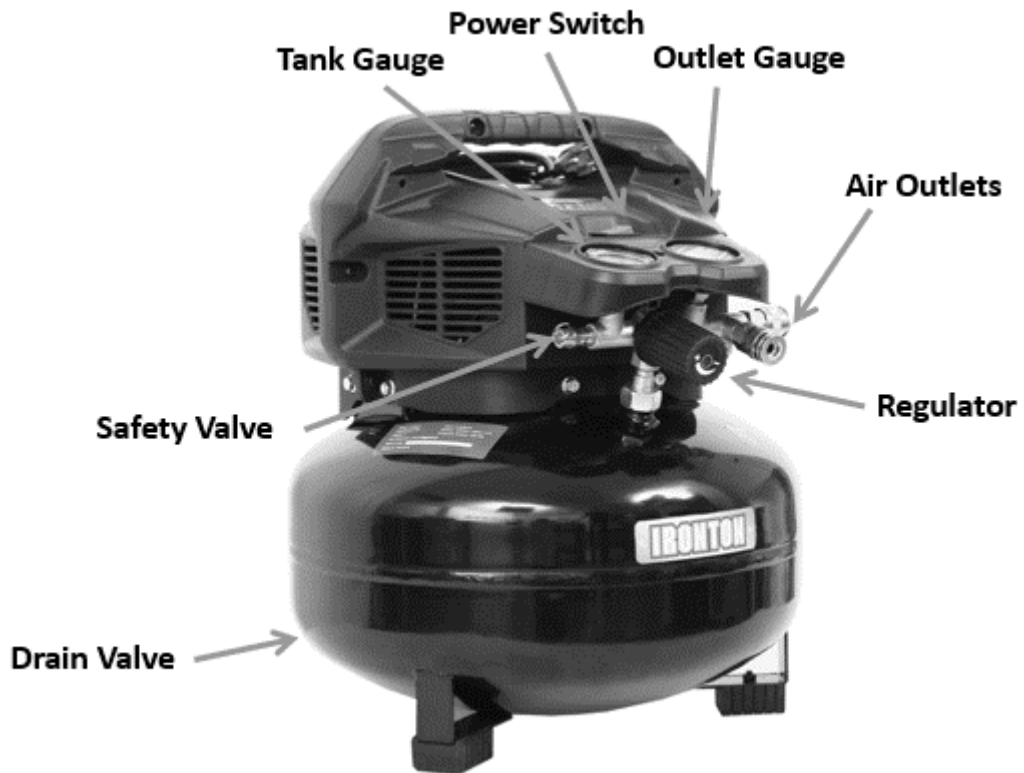

Assembly Instructions

⚠WARNING

Before assembling or making any adjustments to the air compressor.

- Turn the power switch “off”
- Unplug the air compressor from its electrical outlet

Breaking in the air compressor

1. Turn Power Switch to OFF and unplug Power Cord

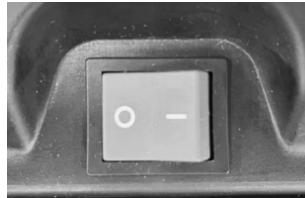

2. Turn Regulator to “+” and fully open it.



3. Fully open Drain Valve.



4. Plug in Power Cord.
5. Turn Power Switch to ON.
6. Let unit run for 15 minutes. Air will expel freely through the Drain Valve.
7. Turn Power Switch to OFF.
8. Unplug Power Cord and close Drain Valve.

Air compressor area Set Up

1. Designate a work area that is clean and well-lit. The work area must not allow access by children or pets to prevent injury.
2. Locate the Air Compressor on a flat level surface to prevent damage to the unit. Keep at least 12" of space around the unit to allow air circulation.
3. Route the power cord from the Air Compressor to the grounded wall outlet, along a safe path without creating a tripping hazard or exposing the power cord to possible damage.

Air connection Setup

1. Connect 1/4" air hose with Industrial (T-style) or Automotive (M-Style) plug (both sold separately) to the Air Outlet. The air hose must be long enough to reach the work area with enough extra length to allow free movement while working.
2. Consult air tool's manual for needed accessories.

Before Each Use

⚠WARNING

To prevent serious injury from accidental operation:

- Turn the power switch “off” and unplug the air compressor from its electrical outlet before performing any inspection, maintenance, or cleaning procedures

Before each use, inspect the general condition of the air Air Compressor. Check for:

1. Loose Hardware,
2. Misalignment Or Binding Of Moving Parts,
3. Cracked Or Broken Parts,
4. Damaged Electrical Wiring, And
5. Any Other Condition That May Affect Its Safe Operation.

Operating Instructions

⚠WARNING

Read the entire important safety information section at the beginning of this manual including all text under subheadings therein before set up or use of this product.

- To prevent serious injury and death from explosion, Do not adjust the internal pressure switch.
- Any change to the automatic pressure levels may cause excess pressure to accumulate, causing a hazardous situation.
- Do not use damaged equipment. if abnormal noise or vibration occurs, have the problem corrected before further use.

General Operation.

1. Close Drain Valve.
2. Close Regulator
3. Turn Power Switch to OFF
4. Plug Power Cord into a grounded 120VAC electrical outlet
5. Turn Power Switch to AUTO.
6. Allow Air Compressor to build up pressure until it cycles off

Note: At the beginning of the day's first use of the Air Compressor, check for air leaks by applying soapy water to connections while the Air Compressor is pumping and after pressure cut-out. Look for air bubbles. If air bubbles are present at connections, tighten connections. Do not use the Air Compressor unless all connections are air tight, the extra air leaking out will cause the Air Compressor to operate too often, increasing wear on the Air Compressor.

Note: As long as the Power Switch is ON, the operation of the Air Compressor is automatic, controlled by an internal pressure switch. The Air Compressor will turn on automatically when the air pressure drops to 120 PSI, and will turn off automatically when the air pressure reaches 150 PSI.

7. Make sure the air tool's throttle or switch is in the OFF position. Connect the air tool to the air hose.

8. Turn the knob clockwise to increase the pressure and counter-clockwise to decrease pressure. Adjust the pressure gradually, while checking the Outlet Pressure gauge to set the pressure.
9. Use the air tool as needed.
10. When finished, turn the Power Switch to OFF.
11. Unplug the Air Compressor.
12. Bleed air from the tool then disconnect the tool.
13. Drain Tank according to Draining Moisture from air tank on page 15.
14. Clean, then store the Air Compressor indoors in upright position out of children's reach.

Emergency Depressurization

If it is necessary to quickly depressurize the Air Compressor, turn the Power Switch OFF. Then, pull on the ring on the Safety Valve to quickly release stored air pressure.



Automatic Shut Off System

1. If the Air Compressor automatically shuts off before reaching its normal cutoff pressure:
 - a. Shut off all tools.
 - b. Turn Power Switch to OFF.
 - c. Unplug Air Compressor.
 - d. Wait until the Air Compressor cools down (about 10 minutes).
 - e. Plug Air Compressor in.
 - f. Turn Power Switch to AUTO.
 - g. Resume operation.
2. Possible causes of repeated automatic shut off of the Air Compressor are:
 - a. Using an extension cord that is too long or narrow;
 - b. An air leak or open hose causing the Air Compressor to cycle too often and build up heat;
 - c. Turning Air Compressor off and on again too quickly.
3. Correct any issues before further use to avoid damage to the Air Compressor.

After Each Use

Wipe external surfaces of the air compressor with a clean cloth. Store compressor indoors in upright position out of children's reach.

Maintenance

⚠WARNING

- Maintain the product by adopting a program of conscientious repair and maintenance in accordance with the following recommended procedures.
- It is recommended that the general condition of any tool be examined before it is used.
- To prevent serious injury from accidental operation: Turn the power switch “off” and unplug the air compressor from its electrical outlet before performing any inspection, maintenance, or cleaning procedures.

Note: the environment in which the air compressor is used, and the frequency of use will affect how often you will need to check the air compressor components and perform maintenance procedures.

Maintenance Interval	Maintenance Point
Daily	<ol style="list-style-type: none"> 1. Make sure all nuts and bolts are tight. 2. Drain moisture from air tank. 3. Check for abnormal noise or vibration. 4. Check for air leaks. To check for air leaks, apply soapy water to joints while the Air Compressor is pressurized. Look for air bubbles. 5. Wipe off any oil or dirt from the Air Compressor.
Monthly	<ol style="list-style-type: none"> 1. Inspect Safety Valve

Draining Moisture from air tank

The Moisture Drain is located under the Tank. It must be used daily to release all trapped air and moisture from the Tank. Doing this will eliminate condensation and prevent tank corrosion.

1. Turn Power Switch OFF.
2. Unplug Compressor.
3. Tilt Compressor, then turn Drain Valve to open it.
4. When all pressure and moisture is released, close Drain Valve.

Troubleshooting

⚠WARNING

- Follow all safety precautions whenever diagnosing or servicing the compressor. Disconnect power supply before service.

Failure	Possible Cause	Corrective Action
Compressor does not start or restart	1. Compressor does not start.	1. No problem. Compressor will start when needed.
	2. Power cord not plugged in properly.	1. Check that cord is plugged in securely.
	3. Incorrect power supply.	1. Check that circuit matches compressor requirements.
	4. Thermal overload switch tripped	1. Turn off Compressor and pull out of plug. Wait for it to cool down. Resume operation.
	5. Cord wire size is too small or cord is too long to properly power compressor.	1. Use larger diameter or shorter extension cord or eliminate extension cord. See Recommended Wire Gauge for Extension Cords in Safety section.
	6. Compressor needs service.	1. Have unit inspected by a qualified technician.
Compressor builds pressure too slowly	1. Incorrect power supply.	1. Check that circuit matches compressor requirements.
	2. Working environment too cold.	1. Move compressor to a warmer location.
	3. Air filter is not clean.	2. Need to check the air filter, replace the dusty filter.
	3. Safety valve leaking.	1. Listen for air leaking from valve. If leaking, replace with identical valve with same rating. Do not seal or tamper with safety valve.
Compressor not building enough air pressure	4. Loose fittings.	1. Reduce air pressure, then check all fittings with a soap solution for air leaks and tighten as needed. Do not overtighten
	1. Check Valve needs service.	1. Have technician clean or replace, as needed.
	2. Compressor not large enough for job.	1. Check if accessory CFM is met by Compressor. If Compressor cannot supply enough Air flow (CFM), use a larger Compressor.

	3. Loose fittings.	1. Reduce air pressure, then check all fittings with a soap solution for air leaks and tighten as needed. Do not overtighten.
	4. Hose or hose connections too narrow.	1. Replace with wider hose and/or hose connections.
	5. High altitude reducing air output.	1. Higher altitudes require compressors with greater output.
Overheating	1. Extension cord used.	1. Eliminate extension cord.
Compressor starts and stops excessively	1. Loose fittings.	1. Reduce air pressure, then check all fittings with a soap solution for air leaks and tighten as needed. Do not overtighten.
	2. Compressor not large enough for job.	1. Check if accessory SCFM is met by Compressor.
Excessive noise	1. Loose fittings.	1. Reduce air pressure, then check all fittings with a soap solution for air leaks and tighten as needed. Do not overtighten.
Moisture in discharge air	1. Too much moisture in air.	1. Install inline air filter/dryer, and/or relocate to less humid environment.
Safety Valve "pops"	1. Safety valve needs service.	1. Pull on the ring on the Safety Valve. If it still pops, replace.
Air leaks from pump or fittings	1. Loose fittings.	1. Reduce air pressure, then check all fittings with a soap solution for air leaks and tighten as needed. Do not overtighten.
Air leaks from tank	1. Defective or rusted tank.	1. Have tank replaced by a qualified technician. 2. Drain moisture from tank daily to prevent future corrosion.

Parts Diagram

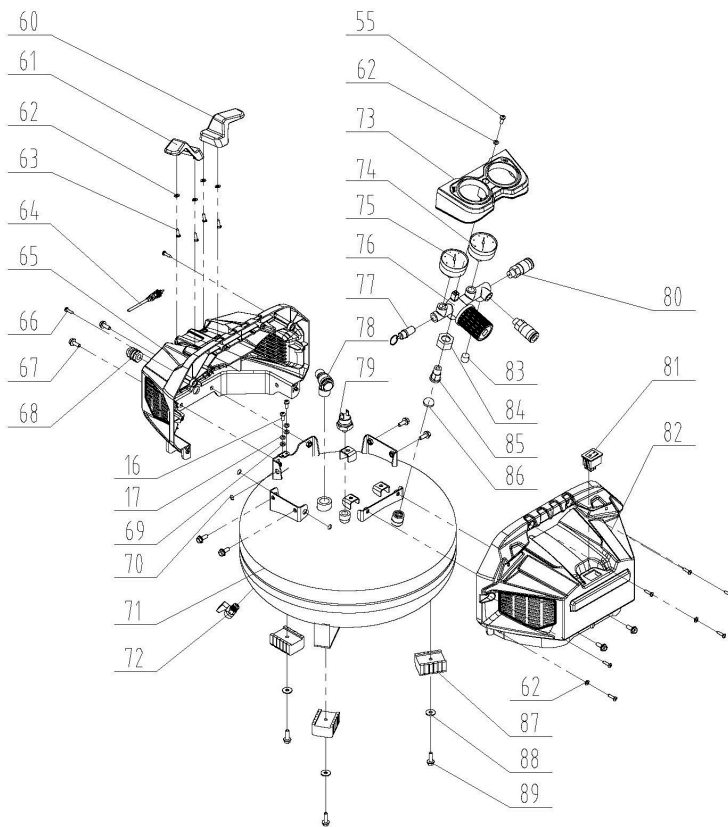
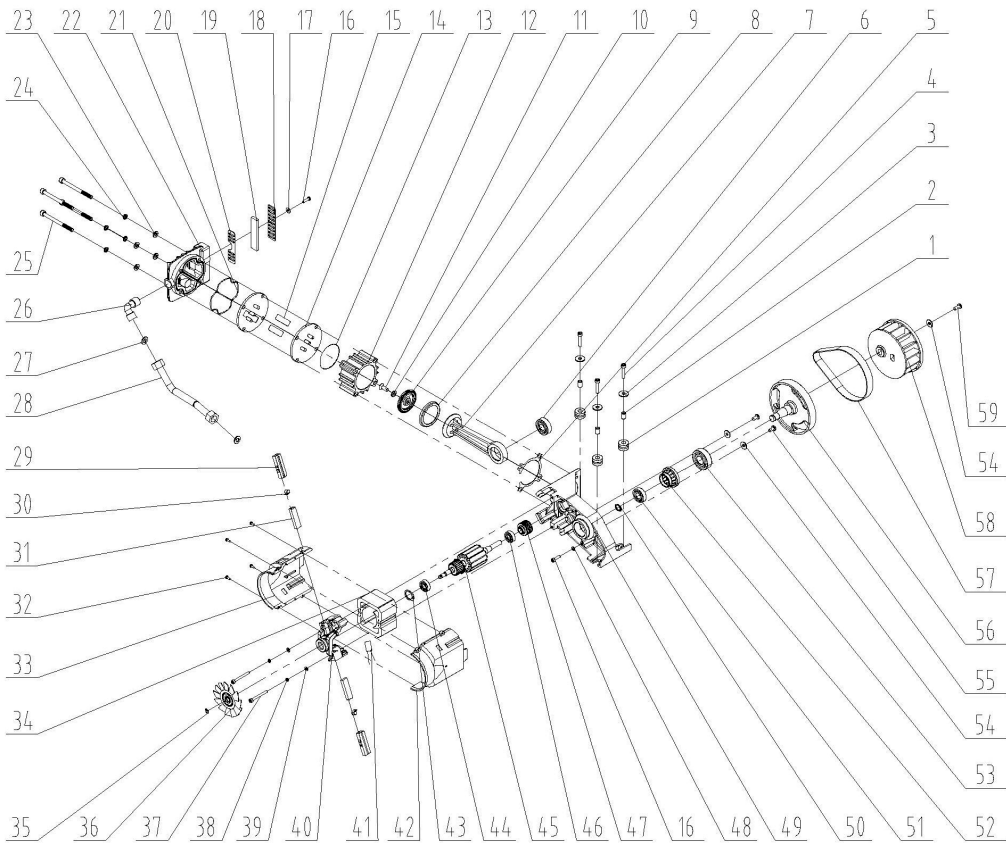

Parts List

Reference	Part Number	Part Description	Quantity
1	1	Crankcase Cushion	3
2	2	Bushing	3
3	3	Flat Washer Φ 5	3
4	4	Hex Flange Bolt M5*25	3
5	5	Cylinder Gasket	1
6	6	Bearing	1
7	7	Connecting Rod	1
8	8	Piston Ring	1
9	9	Piston Cap	1
10	10	Assembled Washer Φ 6	1
11	11	Hex Socket Bolt M6*16	1
12	12	Cylinder	1
13	13	Cylinder Seal	1
14	14	Valve Plate	2
15	15	Valve	2
16	16	Bolt M4*12-	4
17	17	Washer Φ 4	3
18	18	Air Filter Plate-I	1
19	19	Air Filter	1
20	20	Air Filter Plate-II	1
21	21	Sealing	1
22	22	Cylinder Cap	1
23	23	Flat Washer Φ 6	4
24	24	Spring Washer Φ 6	4
25	25	Hex Socket Bolt M6*70	4
26	26	Elbow	1
27	27	Sealing	2
28	28	Exhaust Tube	1
29	29	Brush Case	2
30	30	Coil Spring	2
31	31	Carbon Brush	2
32	32	Cross Binding Head Screw	4
33	33	Shroud-L	1
34	34	Stator	1
35	35	Circlip For Shaft 6	1
36	36	Fan B	1
37	37	Hex Socket Bolt M4*60	2
38	38	Spring Washer Φ 4	2
39	39	Flat Washer Φ 4	2
40	40	Carbon Brush Bracket	1
41	41	Thermal Protector	1
42	42	Shroud-R	1
43	43	Corrugated Washers	1
44	44	Bearing	1
45	45	Rotator	1
46	46	Bearing	1
47	47	Small Pulley	1
48	48	Spring Washer Φ 4	1
49	49	Crankcase	1
50	50	Circlip For Shaft-12	1

Reference	Part Number	Part Description	Quantity
51	51	Bearing	1
52	52	Bearing Sleeve	1
53	53	Bearing	1
54	54	Flat Washer Φ	3
55	55	Cross Binding Head Bolt M5*12	3
56	56	Crankshaft	1
57	57	Belt	1
58	58	Fan C	1
59	59	Hex Socket Head Bolt	1
60	60	Wire Wrap-1	1
61	61	Wire Wrap-2	1
62	62	Flat Washer Φ 5	7
63	63	Cross Binding Head Screw	4
64	64	Power Cord	1
65	65	Shroud-B	1
66	66	Cross Binding Head Screw	8
67	67	Hex Flange Bolt	8
68	68	Strain Relief	1
69	69	Locking Gasket	2
70	70	Wire Harness	3
71	71	Tank Assembly	1
72	72	Drain Valve	1
73	73	Manifold Shroud	1
74	74	Pressure Gauge	1
75	75	Pressure Gauge	1
76	76	Regulator	1
77	77	Safety Valve	1
78	78	Check Valve	1
79	79	Pressure Switch	1
80	80	Coupler	2
81	81	Power Switch	1
82	82	Shroud-F	1
83	83	Choke Plug	1
84	84	Nut	1
85	85	Outlet Fitting	1
86	86	O Ring	1
87	87	Rubber Feet	3
88	88	Flat Washer	3
89	89	Hex Flange Bolt M6*20	3

Replacement Parts

- For replacement parts and technical questions, please call Customer Service at **1-800-222-5381**.
- Not all product components are available for replacement. The illustrations provided are a convenient reference to the location and position of parts in the assembly sequence.
- When ordering parts, the following information will be required: item description, item model number, item serial number/item lot date code, and the replacement part reference number.
- The distributor reserves the rights to make design changes and improvements to product lines and manuals without notice.

Limited Warranty

Northern Tool and Equipment Company, Inc. ("We" or "Us") warrants to the original purchaser only ("You" or "Your") that the **Ironton** product purchased will be free from material defects in both materials and workmanship, normal wear and tear excepted, for a period of **one year** from date of purchase. The foregoing warranty is valid only if the installation and use of the product is strictly in accordance with product instructions. There are no other warranties, express or implied, including the warranty of merchantability or fitness for a particular purpose. If the product does not comply with this limited warranty, Your sole and exclusive remedy is that We will, at our sole option and within a commercially reasonable time, either replace the product or product component without charge to You or refund the purchase price (less shipping). This limited warranty is not transferable.

Limitations on the Warranty

This limited warranty does not cover: (a) normal wear and tear; (b) damage through abuse, neglect, misuse, or as a result of any accident or in any other manner; (c) damage from misapplication, overloading, or improper installation; (d) improper maintenance and repair; and (e) product alteration in any manner by anyone other than Us, with the sole exception of alterations made pursuant to product instructions and in a workmanlike manner.

Obligations of Purchaser

You must retain Your product purchase receipt to verify date of purchase and that You are the original purchaser. To make a warranty claim, contact Us at 1-800-222-5381, identify the product by make and model number, and follow the claim instructions that will be provided. The product and the purchase receipt must be provided to Us in order to process Your warranty claim. Any returned product that is replaced or refunded by Us becomes our property. You will be responsible for return shipping costs or costs related to Your return visit to a retail store.

Remedy Limits

Product replacement or a refund of the purchase price is Your sole remedy under this limited warranty or any other warranty related to the product. We shall not be liable for: service or labor charges or damage to Your property incurred in removing or replacing the product; any damages, including, without limitation, damages to tangible personal property or personal injury, related to Your improper use, installation, or maintenance of the product or product component; or any indirect, incidental or consequential damages of any kind for any reason.

Assumption of Risk

You acknowledge and agree that any use of the product for any purpose other than the specified use(s) stated in the product instructions is at Your own risk.

Governing Law

This limited warranty gives You specific legal rights, and You also may have other rights which vary from state to state. Some states do not allow limitations or exclusions on implied warranties or incidental or consequential damages, so the above limitations may not apply to You. This limited warranty is governed by the laws of the State of Minnesota, without regard to rules pertaining to conflicts of law. The state courts located in Dakota County, Minnesota shall have exclusive jurisdiction for any disputes relating to this warranty.



Distributed by:

Northern Tool & Equipment Company, Inc.

Burnsville, Minnesota 55306

www.northerntool.com

Made in Vietnam