



Instructions : BW2472W4 - Bulk Storage Rack

Parts	(2) - 24" x 72" Welded End Frames
	(8) - 72" Beams
	(8) - 24" x 36" Wire Deck Shelving

Tools Required	Rubber Mallet
-----------------------	---------------

Safety Instructions

This storage rack unit must be placed on a level surface. Failure to do so can result in unit failure, poor product performance, or a possible “**tipping**” safety hazard. **DO NOT STAND ON THE UNIT OR USE THE UNIT AS A LADDER ! DO NOT OVERLOAD !** Evenly distribute the weight on each shelf, and keep the heaviest loads on the bottom shelf. Use care and the proper attire when working with metal parts.

General Instructions

Muscle Rack Bulk Storage Rack is engineered to offer maximum flexibility as well as ease and quickness of assembly. The rack units can stand individually, or for greater stability, be joined together using the common post. Individual beams can be adjusted without disturbing the beams in adjoining units. These instructions should be followed exactly. All parts supplied must be used as shown. Any alteration or deviation from this instruction sheet can result in unit failure. After the unit is assembled, it must be placed on a level surface for safety, and optimal product performance.

Assembly Instructions

Attach the beams to the welded end frames as seen in figure 1. Use both welded end frames to establish the left and the right sides of the units. After a beam has been placed to the end units, tap the beam down at both ends with a rubber mallet to help drive the beam end clip tabs into the end frame post slots to secure the beam to the end frame (see figure 1). **Note: If the beam end clip tabs become bent due to mishandling. It may be necessary to adjust the tabs back to their proper form.**

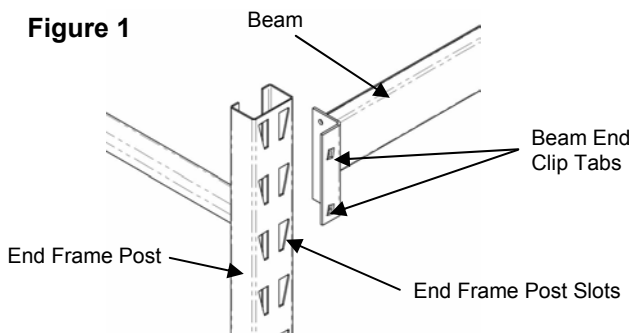

The completed unit should have four (4) levels evenly spaced for maximum stability. Note: Although the beams are adjustable in height, it's recommended to evenly space them so that the stability of the unit is not compromised.

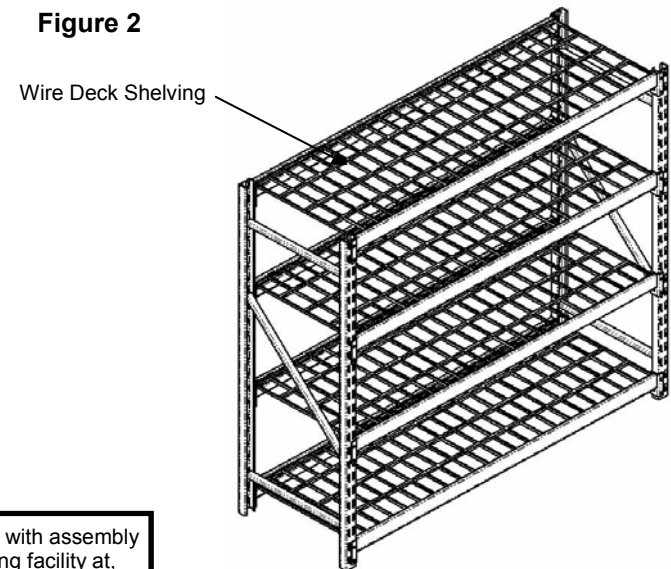

After all beams are in place, place the wire deck shelving (**two (2) 24" x 36" pieces per level**) to each level to complete the unit (see figure 2).

Should you have any comments, damage, missing parts, or problems with assembly of this unit please feel free to contact our Muscle Rack manufacturing facility at, (773) 475-3000 and request customer service. To obtain replacement parts, please provide the following information :

- Model # - Part # & Description - Location Purchased - Date Purchased

Edsal Manufacturing Co., Inc.
Chicago, IL
Made In China