

# KLUTCH

## 4.25 Cu.Ft Cement Mixer

Owner's Manual



**⚠ WARNING:** Read carefully and understand all ASSEMBLY AND OPERATION INSTRUCTIONS before operating. Failure to follow the safety rules and other basic safety precautions may result in serious personal injury.

Item #114829

**READ & SAVE THESE INSTRUCTIONS**

Thank you very much for choosing a Klutch product!

For future reference, please complete the owner's record below:

Serial Number/Lot Date Code: \_\_\_\_\_

Purchase Date: \_\_\_\_\_

Save the receipt, warranty, and this manual. It is important that you read the entire manual to become familiar with this product before you begin using it.

This Cement Mixer is designed for certain applications only. Northern Tool & Equipment is not responsible for issues arising from modification or improper use of this product such as an application for which it was not designed. We strongly recommend that this product not be modified and/or used for any application other than that for which it was designed.

For technical questions, please call **1-800-222-5381**.

## Table of Contents

Intended Use.....	4
Packaging Contents.....	4
Technical Specifications .....	4
Important Safety Information .....	4
Specific Operation Warnings .....	7
Grounding .....	7
Extension Cords.....	8
Main Parts of Product .....	9
Assembly Instructions.....	10
Before Each Use.....	13
Operating Instructions.....	13
After Each Use.....	14
Maintenance .....	15
Troubleshooting.....	16
Parts Diagram .....	17
Parts List.....	18
Replacement Parts .....	19
Limited Warranty.....	20

## Intended Use

Cement mixer handles stucco, mortar or concrete at 36 RPM and is easily rolled nearly anywhere on two large wheels. Constructed of solid steel, this mixer is great for both construction and farm applications such as seed inoculation or mixing feed.

## Packaging Contents

- Motor (1)
- Owner's Manual (1)
- Handle (1)
- Handle Control Plate (1)
- Upper drum (1)
- Rubber seal (1)
- Lower drum (1)
- Blade (2)
- Crossbeam (1)
- Wheel Bracket (1)
- Support Frame (1)
- Wheels (2)

## Technical Specifications

Property	Specification
Voltage	120V AC / 60Hz
Motor Power	2/3 HP
Drum Capacity	4.25 Cu.Ft
Drum Opening	13in.
Drum Speed	36 RPM

## Important Safety Information

### **⚠WARNING**

- Read and understand all instructions. Failure to follow all instructions may result in serious injury or property damage.
- The warnings, cautions, and instructions in this manual cannot cover all possible conditions or situations that could occur. Exercise common sense and caution when using this tool. Always be aware of the environment and ensure that the tool is used in a safe and responsible manner.
- Do not allow persons to operate or assemble the product until they have read this manual and have developed a thorough understanding of how it works.
- Do not modify this product in any way. Unauthorized modification may impair the function and/or safety and could affect the life of the product. There are specific applications for which the product was designed.
- Use the right tool for the job. DO NOT attempt to force small equipment to do the work of larger industrial equipment. There are certain applications for which this equipment was designed. It will be a safer experience and do the job better at the capacity for which it was intended. DO NOT use this equipment for a purpose for which it was not intended.

- Industrial or commercial applications must follow OSHA requirements.

### **⚠WARNING**

- This product may contain chemicals known to the state of California to cause cancer, birth defects, or other reproductive harm.
- Some dust created by power sanding, sawing, grinding, drilling, and other construction activities contains chemicals known to the state of California to cause cancer, birth defects, or other reproductive harm. Some examples of these chemicals are:
  - - lead from lead-based paints,
  - - crystalline silica from bricks and cement and other masonry products, and
  - - arsenic and chromium from chemically-treated lumber.
- Your risk from these exposures varies, depending on how often you do this type of work. To reduce your exposure to these chemicals: work in a well-ventilated area, and work with approved safety equipment, such as dust masks that are specially designed to filter out microscopic particles.
- Handling power cords on corded products may expose you to lead, a chemical known to the state of California to cause cancer and birth defects or other reproductive harm. Wash your hands after handling.

### **⚠WARNING**

#### **WORK AREA SAFETY**

- Inspect the work area before each use. Keep work area clean, dry, free of clutter, and well-lit. Cluttered, wet, or dark work areas can result in injury. Using the product in confined work areas may put you dangerously close to cutting tools and rotating parts.
- Do not use the product where there is a risk of causing a fire or an explosion; e.g., in the presence of flammable liquids, gases, or dust. The product can create sparks, which may ignite the flammable liquids, gases, or dust.
- Do not allow the product to come into contact with an electrical source. The tool is not insulated and contact will cause electrical shock.
- Keep children and bystanders away from the work area while operating the tool. Do not allow children to handle the product.
- Be aware of all power lines, electrical circuits, water pipes, and other mechanical hazards in your work area. Some of these hazards may be hidden from your view and may cause personal injury and/or property damage if contacted.

## **⚠️WARNING**

### **PERSONAL SAFETY**

- Stay alert, watch what you are doing, and use common sense when operating the tool. Do not use the tool while you are tired or under the influence of drugs, alcohol, or medication. A moment of inattention while operating the tool may result in serious personal injury.
- Dress properly. Do not wear loose clothing, dangling objects, or jewelry. Keep your hair, clothing and gloves away from moving parts. Loose clothes, jewelry, or long hair can be caught in moving parts. Air vents on the tool often cover moving parts and should be avoided.
- Wear the proper personal protective equipment when necessary. Use ANSI Z87.1 compliant safety goggles (not safety glasses) with side shields, or when needed, a face shield. Use a dust mask in dusty work conditions. Also use non-skid safety shoes, hardhat, gloves, dust collection systems, and hearing protection when appropriate. This applies to all persons in the work area.
- Do not overreach. Keep proper footing and balance at all times.

## **⚠️CAUTION**

### **PRODUCT USE AND CARE**

- Do not force the product. Products are safer and do a better job when used in the manner for which they are designed. Plan your work, and use the correct product for the job.
- Check for damaged parts before each use. Carefully check that the product will operate properly and perform its intended function. Replace damaged or worn parts immediately. Never operate the product with a damaged part.
- Store the product when it is not in use. Store it in a dry, secure place out of the reach of children. Inspect the tool for good working condition prior to storage and before re-use.
- Use only accessories that are recommended by the manufacturer for use with your product. Accessories that may be suitable for one product may create a risk of injury when used with another tool. Never use an accessory that has a lower operating speed or operating pressure than the tool itself.
- Keep guards in place and in working order. Never operate the product without the guards in place.

## Specific Operation Warnings

### ⚠WARNING

- To prevent serious injury or property damage, read and understand owner's manual before operating.
- Always use the proper protective equipment, including ANSI Z87.1 compliant eye protection, heavy duty work gloves, and hearing protection
- Rotating Parts Hazard. Do not place tools, hoses, hands, arms, or any part of the body inside the drum unless motor is off, and the power cord unplugged.
- Operate on a hard, level surface.
- Do not leave the machine unattended while it is running.
- Electrocutation Hazard. Ensure that the mixer is properly grounded.
- Do not plug or unplug the cord while standing in or around damp or wet ground.
- Do not operate the mixer in wet or damp areas or expose it to rain.
- Turn power off and unplug before servicing.
- Use only outdoor rated, grounded extension cords of the proper size.
- Not for use by or around children.

## Grounding

### ⚠WARNING

- This machine must be grounded while in use to protect the operator from electrical shock. This unit is equipped with an electrical cord that has an equipment grounding conductor and a grounding plug. The plug **MUST** be plugged into a matching receptacle that is properly installed and grounded in accordance with ALL local codes and ordinances.
- **DO NOT MODIFY THE PROVIDED PLUG.** If it will not fit the receptacle, have the proper receptacle installed by a qualified electrician.
- **CHECK** with a qualified electrician or service person if you do not completely understand the grounding instructions, or if you are not sure the tool is properly grounded.

### **Grounded Tools: Tools with 3-Prong Plugs**

Tools marked with **Grounding Required** have a 3-wire cord and 3-prong grounding plug. The plug must be connected to a properly grounded outlet. If the tool should electrically malfunction or break down, grounding provides a low resistance path to carry electricity away from the user, reducing the risk of electric shock. (See Figure A.)

The grounding prong in the plug is connected through the green wire inside the cord to the grounding system in the tool. The green wire in the cord must be the only wire connected to the tool's grounding system and must never be attached to an electrically live terminal.

Your tool must be plugged into an appropriate outlet, properly installed and grounded in accordance with all codes and ordinances. The plug and outlet should look like those in the following illustration.

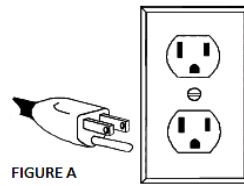

### Double Insulated Tools: Tools with Two-Prong Plugs

Tools marked **Double Insulated** do not require grounding. They have a special double insulation system which satisfies OSHA requirements and complies with the applicable standards of Underwriters Laboratories, Inc., the Canadian Standard Association, and the National Electrical Code. (See Figure B.)

Double insulated tools may be used in either of the 120 volt outlets shown in the following illustration.

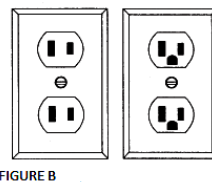

## Extension Cords

### ⚠ WARNING

- **USE A PROPER EXTENSION CORD.** Make sure your extension cord is in good condition. When using an extension cord, be sure to use one heavy enough to carry the current your product will draw. An undersized cord will cause a drop in line voltage, resulting in loss of power and cause overheating.
- Be sure your extension cord is properly wired and in good condition. Always replace a damaged extension cord or have it repaired by a qualified person before using it. Protect your extension cords from sharp objects, excessive heat and damp or wet areas.

- Grounded tools require a 3-wire extension cord. Double Insulated tools can use either a 2- or 3-wire extension cord.
- As the distance from the supply outlet increases, you must use a heavier gauge extension cord. Using extension cords with inadequately sized wire causes a serious drop in voltage, resulting in loss of power and possible tool damage.
- The smaller the wire's gauge number, the greater the capacity of the cord. For example, a 14-gauge cord can carry a higher current than a 16-gauge cord. Minimum extension cord wire size is shown in the following table:

Minimum Wire Size Of Extension Cords				
Nameplate AMPS	Cord Length			
	25'	50'	100'	150'
0-6	18 AWG	16 AWG	16 AWG	14 AWG
6-10	18 AWG	16 AWG	14 AWG	12 AWG

10-12	16 AWG	16 AWG	14 AWG	12 AWG
12-16	14 AWG	12 AWG	NOT RECOMMENDED	

- When using more than one extension cord to make up the total length, make sure each cord contains at least the minimum wire size required.
- If you are using one extension cord for more than one tool, add the nameplate amperes and use the sum to determine the required minimum cord size.
- If you are using an extension cord outdoors, make sure it is marked with the suffix **W-A** (**W** in Canada) to indicate it is acceptable for outdoor use.
- Make sure your extension cord is properly wired and in good electrical condition. Always replace a damaged extension cord or have it repaired by a qualified electrician before using it.
- Protect your extension cords from sharp objects, excessive heat, and damp or wet areas.

## Main Parts of Product

Subassembly
Motor
Upper drum
Lower drum
Handle
Crossbeam
Support Bracket
Wheel Bracket

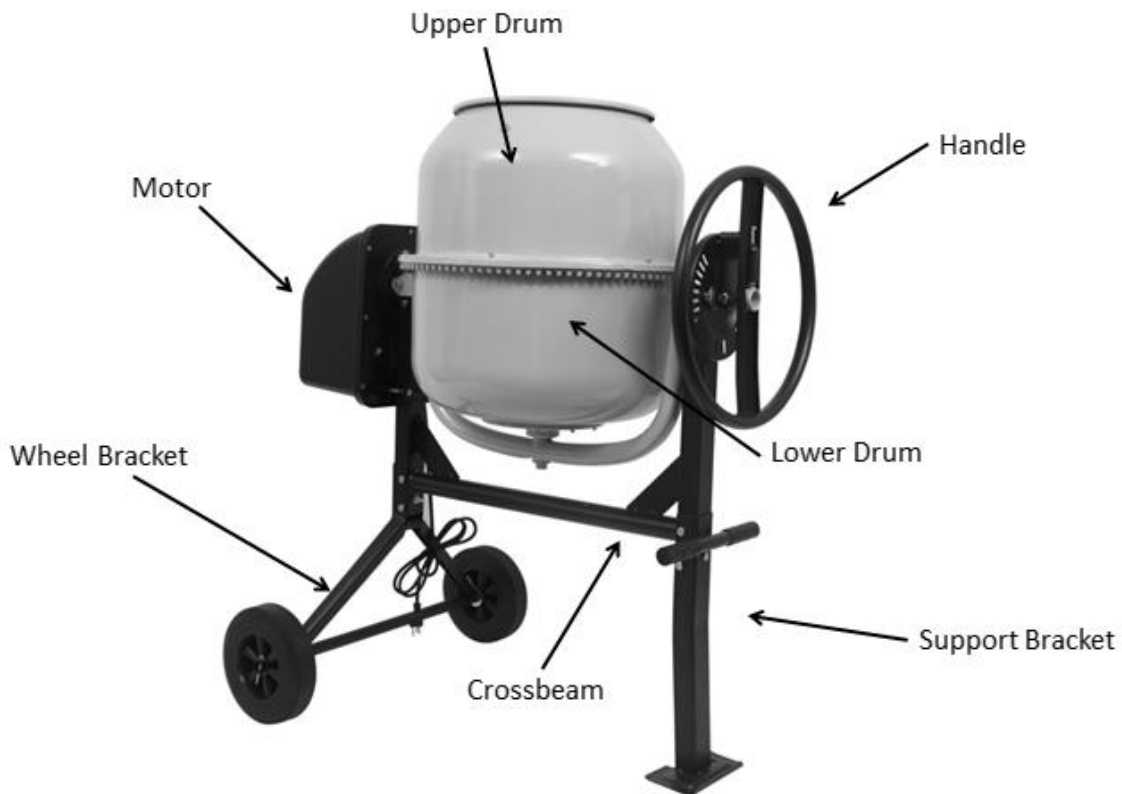

## Assembly Instructions

### ⚠WARNING

- Read the ENTIRE IMPORTANT SAFETY INFORMATION section at the beginning of this manual including all text under subheadings therein before set-up or use of this product.
- TO PREVENT SERIOUS INJURY FROM ACCIDENTAL OPERATION, turn the Power Switch of the tool to the "OFF" position and unplug the tool from electrical outlet before assembling or making any adjustments to the tool.

1. To attach the Wheels (60) to the Wheel Bracket (58), slide the Washer (59), Wheels, and second Washer onto the Bracket Axle. Insert the Cotter Pins (61) into the Bracket's axle holes and split the ends.(See Figure. A)

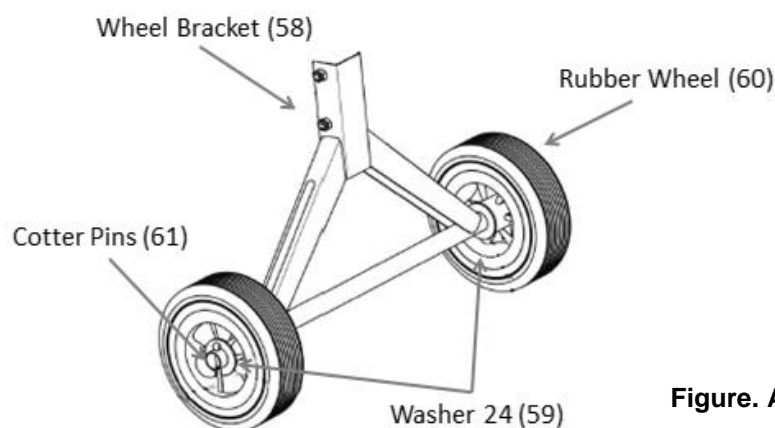

Figure. A

2. Place the Crossbeam (55) into the Wheel Bracket (58) so the bolt holes line up. Fasten together using Hex Bolts (57),Hex Bolt (57), Flat Washers (10), and Hex Nuts (9). Set the stand on its side for easier assembly. (See Figure. B)

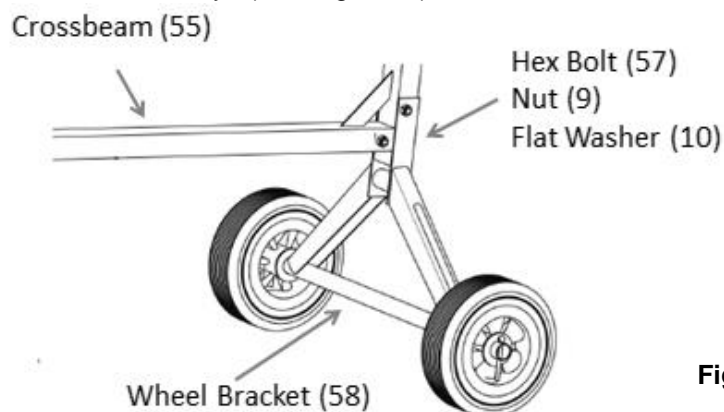
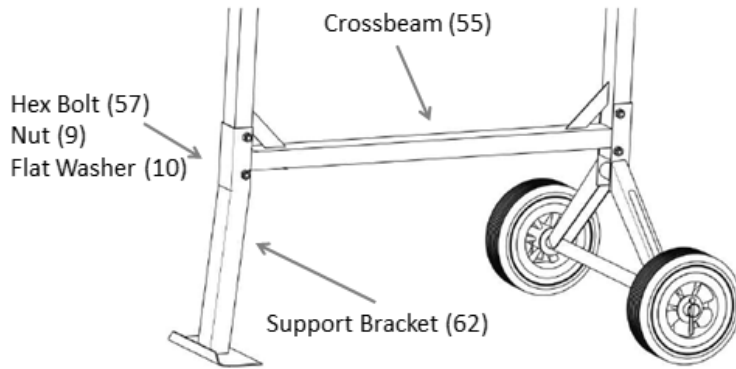

Figure. B

3. Insert the Support Bracket (62) onto the Crossbeam (55) so the bolt holes line up. Fasten together using Hex Bolts (57), Flat Washers (10), and Hex Nuts (9). Tighten with a wrench until secure. Place Crossbeam upright. (See Figure. C)



**Figure. C**

4. With assistance, set the Lower Drum (30) with the attached Aluminum Bracket (13) into the Crossbeam assembly. Fasten together using Hex Bolts (51), Flat Washer (10), and a Hex Nut (9). (See Figure. D)

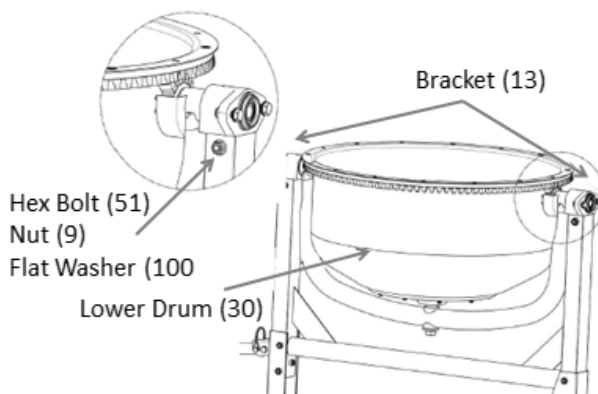

**Figure. D**

5. Use Hex Bolts (11) to mount the Handle Control Plate (8) to the U-Tube (14). Fasten together with Hex Bolt (11), Flat Washer (10) and Hex Nut (9). (See Figure. E)
6. Attach the Control Handle (1) to the U-Tube (14) shaft by inserting the Spiral Spring (2) into the lower hole of Spring Base. Press down on the Spring Base until holes align on the U-Tube (14) end. (See Figure. E).
7. Insert the Hex Bolt (7) and secure with a Hex Nut (5). Tighten to a point where the Handle can still move. (See Figure. E)

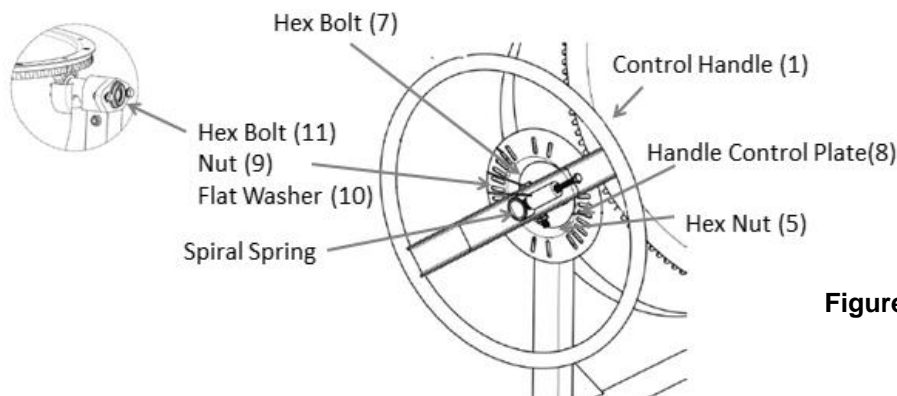

**Figure. E**

8. Use gasket sealer (not included) to attach the Rubber Gasket (33) to the Upper Drum (35), making sure the holes in both align. The Gasket must be flat against the Upper Drum to ensure a proper seal. Place the Upper Drum onto the Lower Drum (30), making sure the mounting holes align in both. Insert the eight Hex Bolts M6x16 (15) into each mounting hole. Fasten Drums together

using an Elastic Washer (16). (See Figure F)

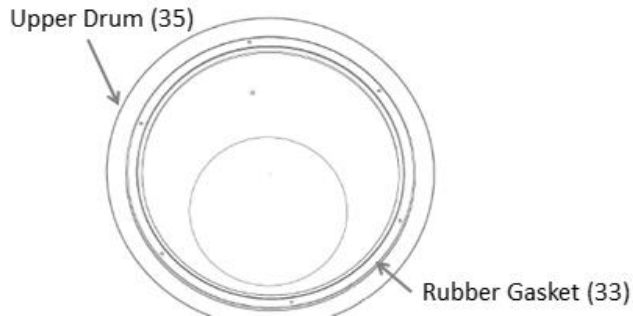

**Figure. F**

9. Mount each Blade (32) inside the assembled Drum with the pointed end facing down. The open end of each Blade should point in the direction of the Drum rotation (counter-clockwise). Fasten the Blades to the Drum using the Hex Bolt (34), Washer (10), and Hex Nut M8 (9).

10. Align the keyhole slots, shifting the Motor Box, block on the pinion shaft. Secure the unit to the frame with the four Hex Bolts M8x60 (51) and washers. (See Figure G)

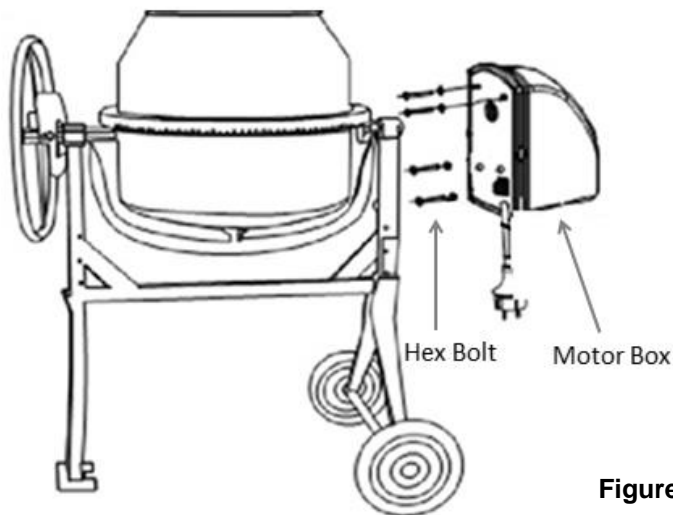

**Figure. G**

11. Check all connections and verify that all screws, nuts, and bolts are securely tightened.

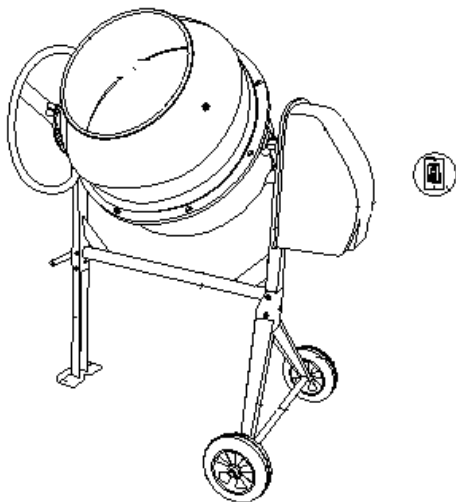

## Before Each Use

Inspect the general condition of the cement mixer. Check for loose hardware, misalignment or binding of moving parts, cracked or broken parts, damaged electrical wiring, damaged or cracked belts, and any other condition that may affect its safe operation.

## Operating Instructions

### **⚠WARNING**

- To prevent serious injury or property damage, read and understand owner's manual before operating.
- Always use the proper protective equipment, including ANSI Z87.1 compliant eye protection, heavy duty work gloves, and hearing protection.
- Rotating Parts Hazard. Do not place tools, hoses, hands, arms, or any part of the body inside the drum unless motor is off, and the power cord unplugged.
- Operate on a hard, level surface.
- Do not leave the machine unattended while it is running.
- Electrocutation Hazard. Ensure that the mixer is properly grounded.
- Do not plug or unplug the cord while standing in or around damp or wet ground.
- Do not operate the mixer in wet or damp areas or expose it to rain.
- Turn power off and unplug before servicing.
- Use only outdoor rated, grounded extension cords of the proper size.
- Not for use by or around children.

1. Connect the Power Cord to an electric outlet (or properly rated grounded three prong extension cord).
2. Add material to the drum.
3. Adjust the Drum angle by pulling on the Handle (22).  
First, disengage the locking pins on the Handle and push on it until the desired angle is reached.  
Re-engage the locking pins.

Flip the switch (34) to the "ON" (I) position.

## Transporting

### ⚠ CAUTION

- Before moving the unit, ensure the drum is empty to reduce the risk of injury.

When transporting the mixer, the Locking Pin (64) must be secured to hold the Lift Bar (23) in place.

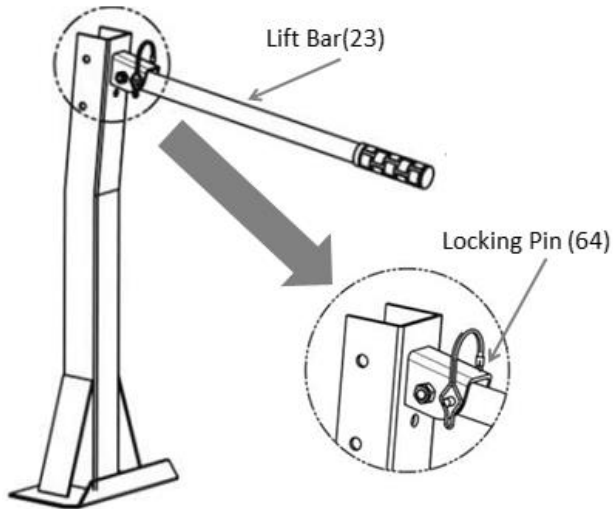

### After Each Use

1. Once materials are mixed, tilt the Drum and dump materials where needed. The materials are dumped while the Drum is rotating.
2. When finished, flip the Switch to the "OFF" (O) position and disconnect the power cord.
3. Tilt the Drum angle as far down as possible to drain all fluids from the Drum.
4. Immediately wash out all debris from the inside and outside of the Cement Mixer. Scrub the inside of the Drum with a stiff, long handled bristle brush for best results. Wipe external surfaces of the tool with clean cloth.
5. Store indoors where children are out of reach.

## Maintenance

### ⚠WARNING

TO PREVENT SERIOUS INJURY FROM ACCIDENTAL OPERATION: Turn the Power Switch of the tool to its "OFF" position and unplug the tool from its electrical outlet before performing any inspection, maintenance, or cleaning procedures.

Maintain the mixer by adopting a program of conscientious repair and maintenance in accordance with the following recommended procedures. It is recommended that the general condition of any tool be examined before it is used. Keep your tool in good repair. Keep handles dry, clean, and free from oil and grease. The following chart is based on a normal operation schedule

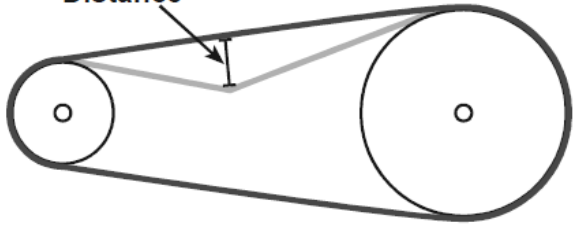
Maintenance Interval	Maintenance Point
Periodically	Recheck all fasteners and other connections for tightness.
Belt Inspection and Tensioning	1. Retighten belt after the first 25 hours of use. To test the tension, follow the steps below.
	1.1 Remove belt cover.
	1.2 Examine belt for cracks, tears in the backing, or other damage. Replace belt if damaged according to steps below: <ul style="list-style-type: none"> <li>● Loosen the motor bracket bolts and slide the bracket up as far as possible Slide the old belt off of the larger pulley first, then remove it from the motor pulley</li> <li>● Put the new belt around the small pulley first, then around the large pulley.</li> <li>● Move the motor bracket down the belt until it is properly tensioned according to the directions below. Tighten the motor bracket bolts.</li> </ul>
	2. Check and adjust belt tension according to the steps below:
	2.1 Press on the center of the longest span on the belt with moderate finger pressure. Then measure the deflection distance, the distance that the belt moved. The belt should deflect anywhere from 1/2" to 3/4". <div style="text-align: center; margin-top: 10px;"> <p><b>Deflection Distance = 1/2" to 3/4"</b></p>  </div>
2.2 If the belt deflects too much, tighten belt by loosening the motor mounting bolts and moving the motor away from the other pulley slightly. Secure motor mounting bolts and retest tension. If the belt is too long to be properly tensioned, it must be replaced.	

	2.3 If the belt deflects too little, loosen the motor bracket bolts and lift it upward. Secure motor mounting bracket and retest tension.
	2.4 Before use, replace belt motor cover.

## Troubleshooting

Use the table below to troubleshoot problems before contacting service personnel or your local dealer. If the problem continues after troubleshooting, call your local dealer for assistance

Failure	Possible Cause	Corrective Action
Tool will not start	1. Cord not connected.	1. Check that cord is plugged in.
	2. No power at outlet.	1. Check power at outlet. If outlet is unpowered, turn off tool and check circuit breaker. If breaker is tripped, make sure circuit has the correct capacity for the tool and circuit has no other loads.
	3. Internal damage or wear	1. Have technician service tool.
Mixer operates slowly. .	1. Extension cord too long or wire size too small.	1. Eliminate use of extension cord. If an extension cord is needed, use shorter/heavier gauge cord. See Extension Cords in GROUNDING section
Excessive noise or rattling.	1. Belt (if equipped) too loose (slipping) or too tight (bearing damage).	1. Properly tension belt.
	1. Internal damage or wear.	1. Have technician service tool
Mixer is Overheating / Overloading.	1. Running at 100% load for extended time.	1. Allow for lighter no-load intervals.
	2. Blocked motor housing vents	1. Wear ANSI-approved safety goggles and NIOSH approved dust mask / respirator while blowing dust out of motor using compressed air.
	3. Motor being strained by long or small diameter extension cord.	1. Eliminate use of extension cord. If an extension cord is needed, use one with the proper diameter for its length and load. See Extension Cords in GROUNDING section



## Parts List

Reference	Part Number	Part Description	Quantity
1	1	Control Handle	1
2	2	Spring	1
3	3	Washer	1
4	4	Hex Bolt M8x50	1
5	5	Hex Nut M10	2
6	6	Flat Washer 10	2
7	7	Hex Bolt M10x70	1
8	8	Handle Control Plate	1
9	9	Hex Nut M8	24
10	10	Flat Washer 8	16
11	11	Hex Bolt M8x25	14
12	12	Circlip 38	4
13	13	Aluminum Bracket	2
14	14	U-Tube	1
15	15	Hex Bolt	9
16	16	Elastic Washer 6	9
17	17	Washer 6	1
18	18	Flat Key A5x16	1
19	19	Gear	1
20	20	Bearing 60102Z	2
21	21	Cover	1
22	22	Next Bearing Plate	1
23	23	Lift Bar	1
24	24	Bearing 60206Z	2
25	25	Shaft	1
26	26	Up Bearing Plate	1
27	27	Aluminum Washer	10
28	28	Washer	10
29	29	Cast Iron Gear Ring	1
30	30	Lower Drum	1
31	31	Crosshead Bolt M6x12	8
32	32	Blade	2
33	33	Rubber Gasket	1
34	34	Hex Bolt M8x20	4
35	35	Upper Drum	1
36	36	Pinion Shaft	1
37	37	Hex Bolt M6x16	6
38	38	Motor Hood	1
39	39	Bearing 60905	2
40	40	Bearing Seat	1
41	41	Drum Pulley	1
42	42	V-Belt	1
43	43	Hex Bolt M8x30	2
44	44	Motor Bracket	1
45	45	Hex Bolt M8x40	3
46	46	Motor	1
47	47	Motor Cover	1
48	48	Cord with Plug	1
49	49	Switch	1

Reference	Part Number	Part Description	Quantity
50	50	Clamp	1
51	51	Hex Bolt M8x60	4
52	52	Washer 14	1
53	53	Elastic Washer 14	1
54	54	Hex Bolt M14x30	1
55	55	Crossbeam	1
56	56	Hex Bolt M8x55	2
57	57	Hex Bolt M8x70	4
58	58	Wheel Bracket	1
59	59	Washer 24	4
60	60	Rubber Wheel	2
61	61	Cotter Pin 5x45	2
62	62	Support Bracket	1

## Replacement Parts

- For replacement parts and technical questions, please call Customer Service at **1-800-222-5381**.
- Not all product components are available for replacement. The illustrations provided are a convenient reference to the location and position of parts in the assembly sequence.
- When ordering parts, the following information will be required: item description, item model number, item serial number/item lot date code, and the replacement part reference number.
- The distributor reserves the rights to make design changes and improvements to product lines and manuals without notice.

## Limited Warranty

Northern Tool and Equipment Company, Inc. ("We" or "Us") warrants to the original purchaser only ("You" or "Your") that the Klutch product purchased will be free from material defects in both materials and workmanship, normal wear and tear excepted, for a period of **one year** from date of purchase. The foregoing warranty is valid only if the installation and use of the product is strictly in accordance with product instructions. There are no other warranties, express or implied, including the warranty of merchantability or fitness for a particular purpose. If the product does not comply with this limited warranty, Your sole and exclusive remedy is that We will, at our sole option and within a commercially reasonable time, either replace the product or product component without charge to You or refund the purchase price (less shipping). This limited warranty is not transferable.

### Limitations on the Warranty

This limited warranty does not cover: (a) normal wear and tear; (b) damage through abuse, neglect, misuse, or as a result of any accident or in any other manner; (c) damage from misapplication, overloading, or improper installation; (d) improper maintenance and repair; and (e) product alteration in any manner by anyone other than Us, with the sole exception of alterations made pursuant to product instructions and in a workmanlike manner.

### Obligations of Purchaser

You must retain Your product purchase receipt to verify date of purchase and that You are the original purchaser. To make a warranty claim, contact Us at 1-800-222-5381, identify the product by make and model number, and follow the claim instructions that will be provided. The product and the purchase receipt must be provided to Us in order to process Your warranty claim. Any returned product that is replaced or refunded by Us becomes our property. You will be responsible for return shipping costs or costs related to Your return visit to a retail store.

### Remedy Limits

Product replacement or a refund of the purchase price is Your sole remedy under this limited warranty or any other warranty related to the product. We shall not be liable for: service or labor charges or damage to Your property incurred in removing or replacing the product; any damages, including, without limitation, damages to tangible personal property or personal injury, related to Your improper use, installation, or maintenance of the product or product component; or any indirect, incidental or consequential damages of any kind for any reason.

### Assumption of Risk

You acknowledge and agree that any use of the product for any purpose other than the specified use(s) stated in the product instructions is at Your own risk.

### Governing Law

This limited warranty gives You specific legal rights, and You also may have other rights which vary from state to state. Some states do not allow limitations or exclusions on implied warranties or incidental or consequential damages, so the above limitations may not apply to You. This limited warranty is governed by the laws of the State of Minnesota, without regard to rules pertaining to conflicts of law. The state courts located in Dakota County, Minnesota shall have exclusive jurisdiction for any disputes relating to this warranty.

# KLUTCH

Distributed by:

Northern Tool & Equipment Company, Inc.

Burnsville, Minnesota 55306

[www.northerntool.com](http://www.northerntool.com)

Made in **China**