



M805018A.7

ITEM NUMBER:
114654 (804311) , 114655 (804312)

SERIAL NUMBER: _____

Owner's Manual Engine: Instructions for Set-up, Operation, Maintenance, Handling & Storage

WARNING

SPECIAL HAZARDS

- **CO Poisoning:** Exhaust from engine contains carbon monoxide, a poisonous gas that can cause carbon monoxide poisoning and possible death if inhaled.
- **Flying Debris:** Engine can cause flying debris.
- **Electric Shock:** Operating equipment in wet conditions or near water can cause electric shock.
- **Fire/Explosion:** Engine sparking can ignite fuel or other flammable liquids or vapors in the vicinity. Hot exhaust from engine can ignite combustible materials.
- **Burns:** Engine have hot surfaces that can cause burn injuries.

Detailed safety information about these hazards appears throughout this manual.

Equipment Protection Quick Facts

Inspect Upon Delivery: FIRST! Inspect for missing or damaged components. See "*Initial Set-Up*" section for where to report missing or damaged parts.

*****Add Engine Oil:** Engine is shipped **without oil**. See Operations instructions for information on capacity and viscosity recommendations.

Storage: See "*Storage*" section for more information.

Maintenance Schedule: Engine requires periodic inspection and servicing to keep functioning efficiently. See "*Maintenance Schedule Summary*" in "*Storage*" section for frequency of servicing.

Any Questions, Comments, Problems, or Parts Orders

Call NorthStar Product Support 1-800-270-0810

Table of Contents

About Engine	3
Specifications	4
Component Identification	5
Safety	6
Safety Labeling.....	7
Initial Set-Up	9
Operation	10
Step 1. Operation Instruction	10
Step 2. Preparing For operation	11
Step 3. Add Fuel	12
Step 3. Start/Stop Engine.....	13
Maintenance	15
Storage.....	19
Troubleshooting	20
Engine Parts Explosion	21
Electrical Schematic Diagram	31
Limited Warranty	32

About Engine

Thank you for purchasing your NorthStar Engine! It is designed for long life, dependability, and top performance.

Intended Use. The engines in this manual can be used in pressure washers, air compressor, water pump, and other similar outdoor power equipment.

Note: Do not use for other unapproved purposes, as unforeseen hazards or equipment damage may result.

Supplies Required. Normal operation will require you to supply:

- Gasoline
- Engine oil
- Personal Protection Equipment

See “*Specifications*” section of this manual for more detail.

Site Location. Intended for outdoor use only.

Personal Protection. Wear safety apparel during operation, including safety glasses with side and top protection. Ear protection is also recommended if working near any operating engine. Other safety apparel includes waterproof, insulated gloves and non-slip protective footwear.

Adult Control only. Only trained adults should operate this engine. Do not let children operate this engine.

Under The Influence. Never operate, or let anyone else operate, this engine while fatigued or under the influence of alcohol, drugs, or medication.

Keep this manual for reference and review.

ATTENTION: Rental Companies and Private Owners who loan this equipment to others!

All persons to whom you rent/loan equipment powered by this engine, must have access to and read this manual. Keep this owner's manual with the engine/product at all times and advise all persons who will operate the engine to read it. You must also provide personal instruction on how to safely set-up and operate the engine and remain available to answer any questions a renter/borrower might have. Owner's Manuals are available from NorthStar at 1-800-270-0810.

Specifications

114654 (804311) – c180	
DIMENSIONS/COMPONENTS	
Engine Type	Four- stroke, Overhead, Single-Cylinder
Length	16.34in
Width	12.20in
Height	14.17in
Net Weight	37.5lbs
Displacement	179cc
Fuel Tank Capacity	.87 Gal (3.3L)
Compression Ratio	8.3: 1
Cylinder Diameter X Stroke	2.56X2.13 in
Maximum Output Power	3.7 kW / 3600 rpm
Net Torque	9.5 ft-lbs. / 2500 rpm
Cooling System	Forced Air Cooling
Ignition System	Transistorized Coil Ignition (TCI)
Spark Plug	F6RTC / F7RTC
Lubrication System	Splash Type
Oil Capacity	0.58 qt. (18.6 oz.)
Power Output Shaft Direction	Counterclockwise
Output Shaft	¾" x 2.43" Length with 3/16" keyway
Mounting Face	SAE J609 Flange A (4) 5/16-24 thread on 3.625" bolt circle
Clearance of spark plug	0.028 – 0.031 in
Valve clearance	0.002 – 0.0039 in
Operating Temperature (°F)	23°F to 104°F

114655 (804312) – c225	
DIMENSIONS/COMPONENTS	
Engine Type	Four- stroke, Overhead, Single-Cylinder
Length	16.34in
Width	12.20in
Height	14.17in
Net Weight	37.5lbs
Displacement	224cc
Fuel Tank Capacity	.87 Gal (3.3L)
Compression Ratio	8.5: 1
Cylinder diameter X Stroke	2.83X2.17 in
Maximum Output Power	4.6 kW / 3600 rpm
Net Torque	13 ft-lbs. / 2500 rpm
Cooling System	Forced Air Cooling
Ignition System	Transistorized Coil Ignition (TCI)
Spark Plug	F6RTC / F7RTC
Lubrication System	Splash Type
Oil Capacity	0.58 qt. (18.6 oz.)
Power Output Shaft Direction	Counterclockwise
Output Shaft	¾" x 2.43" Length with 3/16" keyway
Mounting Face	SAE J609 Flange A (4) 5/16-24 thread on 3.625" bolt circle
Clearance of spark plug	0.028 – 0.031 in
Valve clearance	0.002 – 0.0039 in
Operating Temperature (°F)	23°F to 104°F

Component Identification

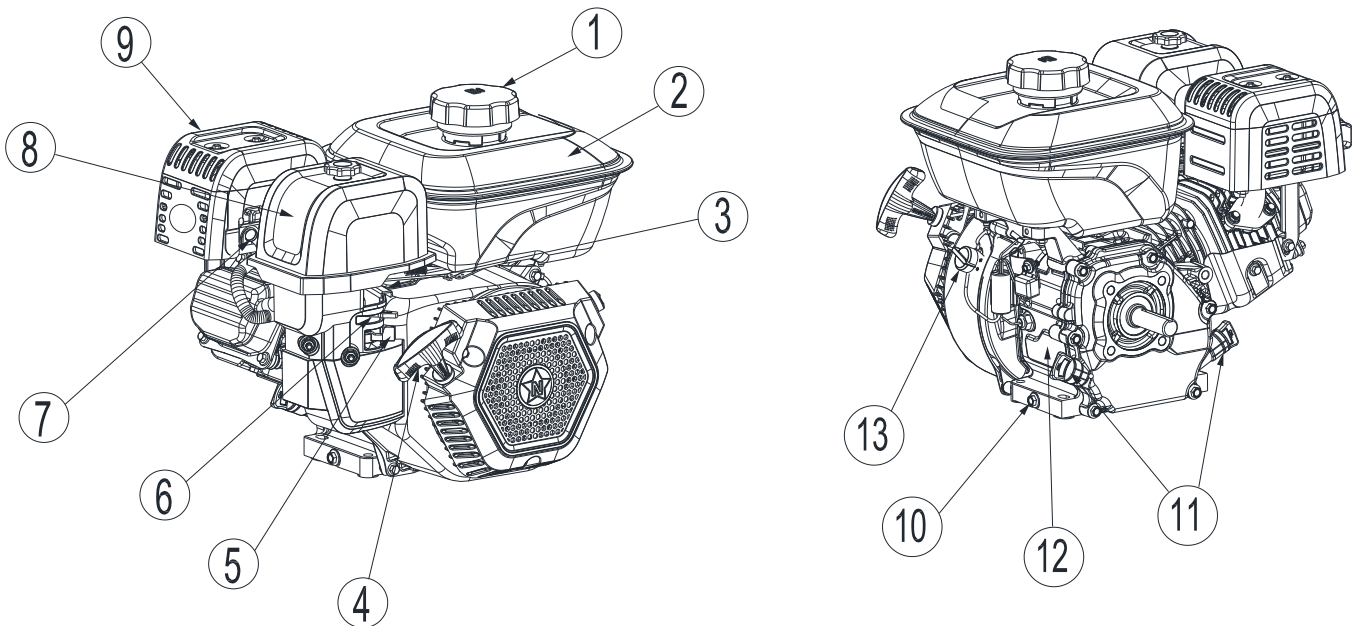

FIG804311_1

1. **Fuel Tank Cap:** Remove the fuel tank cap to add fuel once engine has cooled.
2. **Fuel Tank:** Storage for gasoline to power the engine.
3. **Throttle Lever:** Adjust the engine speed with the throttle lever.
4. **Starter Recoil Handle:** Pull the Starter Recoil handle to start the engine.
5. **Fuel Shutoff:** On/Off valve for fuel supply, shut off after every use.
6. **Choke Lever:** Use the choke when starting a cold engine.
7. **Spark Plug:** Ignites compressed fuel and air within the combustion chamber of the engine.
8. **Air Cleaner:** Prevents dust and debris from entering the carburetor.
9. **Muffler:** The muffler reduces noise from engine. It will become hot during operation, do not touch.
10. **Oil Drain Bolt:** Remove oil drain plug to drain oil from the engine. See “Maintenance” section of this manual.
11. **Oil Dipstick:** Remove either oil dipstick and inspect to ensure proper oil level in engine.
12. **Serial Number:** Unique engine serial number.
13. **Engine On/Off Switch:** To switch on/shutoff the engine.

See “Parts Explosion” for more details

Safety

Hazard Signal Word Definitions



This is the safety alert symbol. It is used to alert you to potential personal injury hazards. Obey all safety messages that follow this symbol to avoid possible injury or death.

DANGER (red) indicates a hazardous situation, which if not avoided, will result in death or serious injury.

WARNING (orange) indicates a hazardous situation, which if not avoided, could result in death or serious injury.

CAUTION (yellow) used with the safety alert symbol, indicates a hazardous situation, which if not avoided, could result in minor or moderate injury.

CAUTION (yellow) without the safety alert symbol, is used to address practices not related to personal injury.

NOTICE is used to address practices not related to personal injury.

Safety Labeling

Safety Decal Locations

⚠ WARNING

ALWAYS make sure safety labels are in place and in good condition. If a safety label is missing or not legible, order new labels from NorthStar Product Support at 1-800-270-0810.

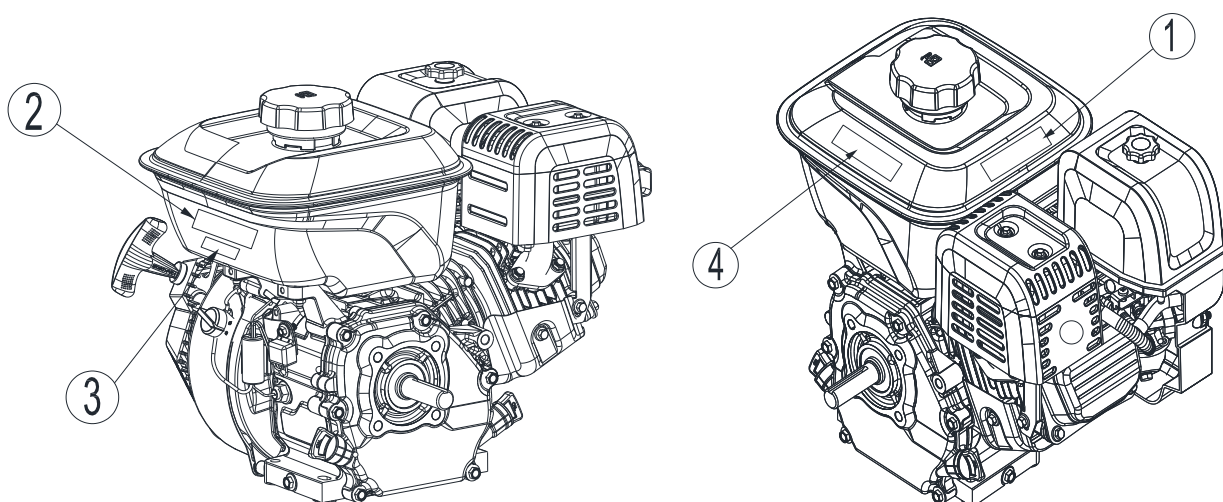

On-Product Warning Labels		
Location	Part Numbers	Description
1	790852	Burn Hazard Decal
2	805216	Fuel Fire / Explosion Hazard
3	805037	Allowable Ethanol % In Fuel
4	805132	Poisonous Gas Decal

Safety Labeling

1



2

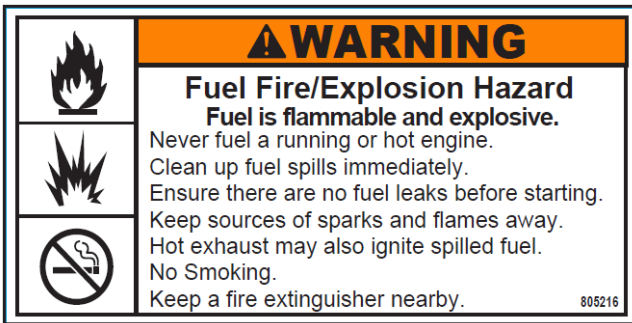

3



4

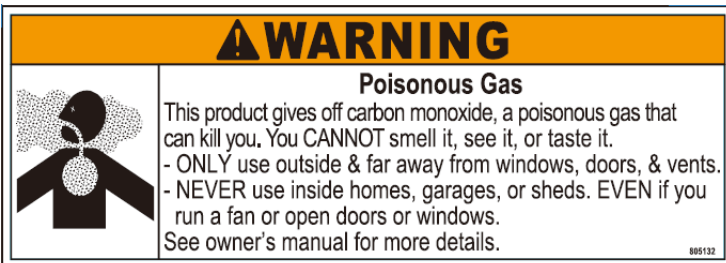

To order replacement safety labels, call NorthStar Product Support at 1-800-270-0810.

Initial Set-Up

Outdoor Use Only

WARNING

Location Hazards

Choose a suitable site for operating your engine to prevent possible death from carbon monoxide poisoning or injury from fire/explosion, hot surfaces, or equipment tip-over.

Select a suitable outdoor location:

1. Never run the engine in an enclosed or partially enclosed location such as a building, garage, barn, shed, or house. These spaces can trap poisonous gases. Running a fan or opening windows will not provide adequate ventilation to prevent dangerous CO build-up.
2. Only use the engine outdoors at least 20 feet from the home, away from windows, vents, and air intakes, to allow proper ventilation. If you start to feel sick, dizzy, or weak while using the engine, shut off the engine and get to fresh air RIGHT AWAY.
3. Position the engine so that the exhaust fumes will not be directed towards people or building air intakes.
4. Do not locate and use the engine in the presence of flammable vapors, dust, gases, or other potentially combustible materials.
5. Ensure that working, battery-operated or battery back-up carbon monoxide alarms are used in any dwelling/structure that is in close proximity to the running engine.

Positioning:

1. Ensure the engine is positioned on a firm, level (less than 3-degree slope), heat-resistant surface.
2. Situate so there is adequate pulling room for starting the engine using the recoil starter. Attempting to pull at an odd angle could rip off grip cord and/or cause muscular injuries to the operator.

Airflow:

1. Situate so there is adequate clearance around the engine to allow for airflow – at least 7 feet from any non-combustible wall or obstruction.

2. Do not place any objects against or on top of the engine.
3. The engine needs adequate, unobstructed flow of air to allow for proper combustion and adequate cooling. Proper combustion can only be obtained when there is a sufficient supply of oxygen available for the amount of fuel being burned. Cooling ventilation is required to prevent overheating of the engine and possible fire.

Exhaust:

WARNING

Exhaust Modification Hazard

Never attempt to attach ductwork to the muffler system to allow for installation inside an enclosure. This could cause heat build-up and increased exhaust back-pressure, resulting in possible exhaust leakage or damage to the engine.

1. The exhaust gas from your engine is extremely hot and can cause combustible materials to catch on fire.
2. Make sure the engine is at least 7 feet from all combustible materials and structures during operation.
3. Keep a fire extinguisher rated "ABC" nearby. Keep it properly charged and be familiar with its use.
4. Place the engine so that the exhaust fumes will not be directed towards people or building air intakes.

DANGER

Carbon Monoxide Hazard

Exhaust fumes from the engine contain carbon monoxide (CO), a poisonous gas you cannot see, smell, or taste. The CO generated by the engine can rapidly accumulate, even in areas that appear to be well ventilated, resulting in dangerous and fatal concentrations within minutes. NEVER run engine inside any enclosed or semi-enclosed spaces, including homes, garages, basements, sheds, boxes, pick-up truck beds, RVs, or boats. These spaces can trap poisonous gases, EVEN if you run a fan or open windows. If you start to feel sick, dizzy, or weak while using the engine, shut off the engine and get to fresh air RIGHT AWAY. See a doctor. You may have carbon monoxide poisoning.

Operation

Follow Safety Rules for Operation

After you have checked, oiled, and fueled the equipment and positioned it in a suitable worksite, it is time to start your engine. The following are the procedures necessary for safe, successful operation of your engine.



WARNING

Failure to follow safety rules may result in serious injury or death to the operator or bystanders.

Instruct Operators. Owner must instruct all operators in safe set-up and operation. Do not allow anyone to operate the engine who has not read the Owner's Manual and been instructed on safe use practices.

Safety Equipment/Controls. Always operate with all safety covers, guards, and barriers in place and in good working order, and all controls properly adjusted for safe operation.

Moving Parts. Keep hands, feet, hair, and apparel away from moving parts. Air vents may cover moving parts and should be avoided as well.

Ear Protection. Hearing can be damaged from prolonged, close-range exposure to the type of noise produced by this engine. The use of ear plugs, or other hearing protection devices is recommended for persons working within 15-20 feet of the running engine for an extended period of time.

Eye Protection. Wear ANSI "Z87.1" required safety glasses when operating or servicing the engine.

NOTE!

Before starting the engine, review the following general safety rules for operation:

Conditions for Use

Know How to Stop. Be thoroughly familiar with proper use of the equipment and all controls and connections. Know how to stop the engine and depressurize the system quickly if needed.

Instruct All Operators. The engine owner must instruct all operators and potential renters in safe set-up and operation. Do not allow anyone to operate the engine who has not read the Owner's Manual and been instructed on its safe use.

Adult Control only. Only trained adults should set up and operate the engine. Do not let children operate. Engine can generate forces greater than children can control and require judgment beyond what can be expected of children.

Under the Influence. Never operate, or let anyone else operate, the engine while fatigued or under the influence of alcohol, drugs, or medication.

Safety Equipment / Controls in place. Do not operate the engine unless all safety covers, guards, and barriers are in place and in good working order, and all controls are properly adjusted for safe operation.

Damaged. Do not operate the engine with damaged, missing, or broken parts. Never attempt to repair a component. Always replace it with a part that is rated.

Modifications. Do not modify the engine in any way or deactivate any safety device. Do not change or add to fuel tank, fuel lines, or exhaust system. Modifications can result in hazards related to carbon monoxide poisoning, fuel leaks, fire, explosion, or other serious safety hazards, and will also void the warranty.

During Use

Stay alert. Watch what you are doing at all times.

Clear work area. Clear the work area of all bystanders.

Keep children and pets away.

Keep engine away from electrical wiring. Engine contact with electrical wiring will likely result in severe electrical shock or electrocution.

Hot exhaust/parts. Stay clear of engine exhaust. Never touch a hot engine muffler, or other hot surfaces. All are very hot and will burn you. Cleaning should be done with a damp sponge with the engine OFF.

Let engine cool at least two minutes before refueling.

Operation

Preparing for Operation

Make sure that any regular maintenance has been performed as prescribed in “Maintenance” section.

Check/Add Engine Oil

Use the recommended oil type for your engine and expected ambient conditions.

WARNING

Burn Hazard

Never open oil port while engine is running. Hot oil can spray over face and body.

Notes:

- Low oil shutdown feature prevents the engine from starting without sufficient oil.
- Engine is shipped without oil. You must add oil before first use.

Engine Oil. Use 4-stroke engine oil, API service classification SN class or equivalent and above. Check the API label on the oil container to be sure it includes the letters SN class or equivalent and above.

SAE 10W-30 is recommended for general use. Other viscosity shown in the chart may be used when the average temperature in your area is within the indicate range.

SAE Viscosity Grades

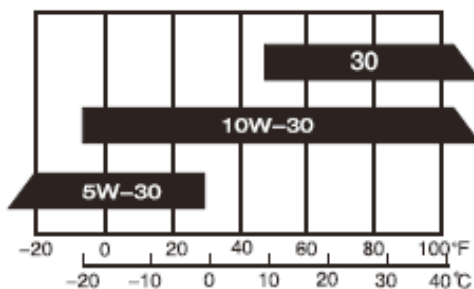

CAUTION

Oil is an important factor affecting the output and life of the engine. Do not use unclean oil or two-stroke oil, which may cause damage to the engine.

Oil level check:

1. Remove the oil dipstick and clean it with a rag.
2. Reinsert the dipstick into the oil filling hole without screwing it in. Pull the dipstick out and check the oil level. The dipstick has an “H” to indicate proper oil level, and an “L” to indicate oil level is too low.
3. If the oil level is too low, the engine will not start. Add the recommended engine oil, to the “H” mark on the oil dipstick.
4. Reinstall the dipstick.
5. Oil Capacity=0.58 qt. (18.6 oz).

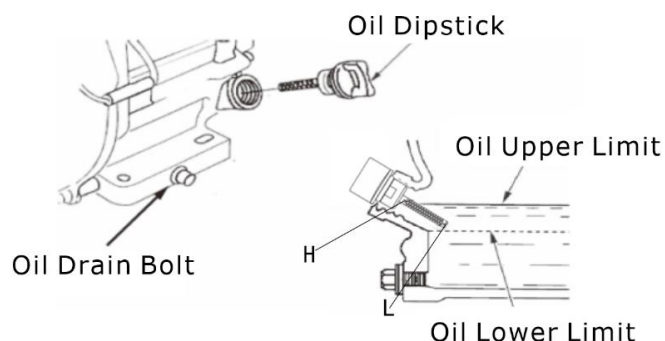

CAUTION

Running the engine with insufficient engine oil may damage the engine severely and would not be covered under warranty.

Air Cleaner

Remove the air cleaner cover and check the filter to make sure it is clean and not damaged. Clean or replace as necessary. See “Maintenance” section of this manual for details.

CAUTION

Never run the engine without the air filter and cover installed or damage to the engine could result. Damage to the engine by not having the air filter and cover installed is not covered under warranty.

Operation

Add Fuel

! WARNING

Fuel Fire/Explosion Hazard

Gasoline is highly flammable and explosive. Heat, sparks, and flames can ignite fuel vapors, which can become widespread during fueling. A flash fire and/or explosion could result and cause serious injury or death. Always use extreme care when handling fuels. Carefully follow all instructions to avoid the following conditions which could result in fuel ignition:

- gas vapor collection inside enclosures
- static electric sparks
- sparks from electric wiring, batteries, or running engines
- sources of heat (such as a hot engine exhaust)
- open flames, including pilot lights

Always follow these general safety rules when fueling:

- 1) Turn engine off and allow to cool for at least two minutes before removing any fuel tank cap.
Note: A running, or still-hot engine is hot enough to ignite fuel.
- 2) Fill fuel tank OUTDOORS – never indoors. Fuel vapors can ignite if they collect inside, and enclosure and explosion can result.
- 3) Stay away from all sources of heat, sparks, and flames. Do not smoke.
- 4) Never pump fuel directly into the gas tank at a gas station – it could cause a static electric spark. Follow these steps to avoid static electric sparking during fueling:
 - Always place container on the ground to be filled. Never fill the portable gas container while it is sitting inside a vehicle, trailer, trunk, or pick-up truck bed.
 - Dissipate static charge from your body before beginning the fueling process by touching a grounded metal object at a safe distance from fuel sources.
 - Keep nozzle in contact with container while filling. Do not use a nozzle lock-open device.
- 5) Clean up fuel spills/splashes immediately.

- Wipe up spilled fuel and wait 5 minutes for excess fuel to evaporate before starting engine.
- Fuel-soaked rags are flammable and should be disposed of properly.
- If fuel is spilled on your skin or clothes, change clothes and wash skin immediately.

Fill Engine Fuel Tank

Check the gasoline tank level. If needed, fill tank with fresh unleaded gasoline from a portable container:

- 1) Remove engine fuel tank cap.
- 2) Add gasoline through the fill opening:
 - Use only a UL-approved portable gasoline container to transfer the gasoline to engine's tank.
 - Do NOT overfill the gasoline tank. Remember to never fill fuel over the fuel filler shoulder.
- 3) Replace fuel tank cap securely before starting engine.
- 4) Store extra gasoline in a cool, dry place in a UL-approved container.

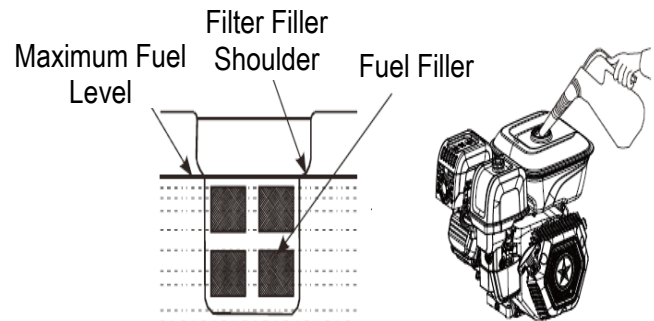

Operation

Inspect Fuel System/Check for Leaks

Inspect the engine fuel system and check for leaks before each use.

Do not start engine until all needed repairs have been completed.

⚠ WARNING

Fuel Leak Hazard

Gasoline fuel is highly explosive and fuel leaks can result in fire or explosions. You can be burned and seriously injured if the fuel system is not properly hooked up or there is a fuel leak when you start the engine.

Inspect the entire fuel system. Look for:

- signs of leaks or deterioration
- chafed or spongy fuel hose

Perform Scheduled Maintenance, As needed

- Make sure that any other regular maintenance has been performed as prescribed in this manual in the "Maintenance Schedule Summary" section.
- Refer to the engine Owner's manual for engine maintenance instructions.

Starting the Engine:

- 1) Turn the fuel shutoff to the "ON"(OPEN) position.

Fuel Shutoff

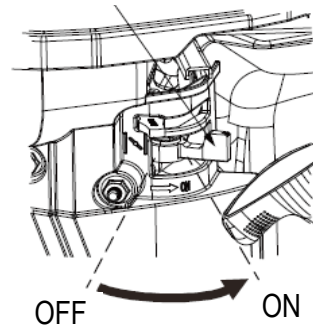

- 2) Turn the choke lever to the "CLOSE"(CHOKE) position.

Note: If the engine is hot from use, don't close the choke.

Choke Lever

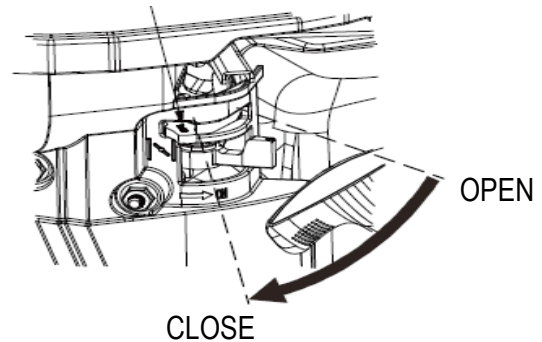

- 3) Move throttle lever to the left a little.

Throttle Lever

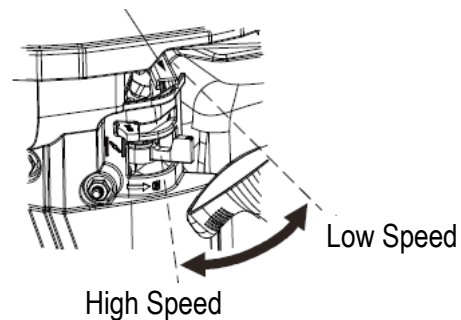

Operation

5) Start the engine.

- Turn the engine switch to the "ON" (START) position.

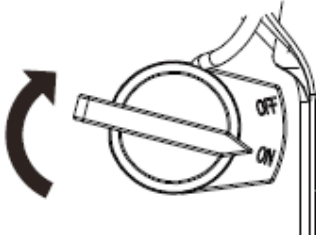

- Gently pull the starter rope handle until you feel the resistance, then pull it out with force and speed to the upper slope.

CAUTION

Do not release the starter handle suddenly after starting to avoid it from recoiling back and hitting the engine. It should be released slowly with the rebound of the starter rope.

Recoil Starter Grip

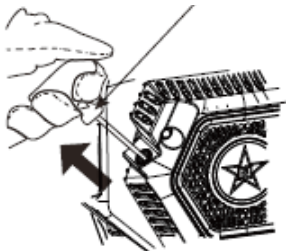

6) Once the engine is running

- Push the choke lever to the (OPEN) position.

Choke Lever

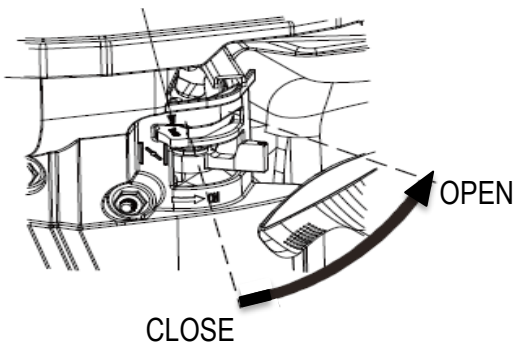

- Move the throttle lever to proper position to run at the required speed.

CAUTION

If the engine cannot be started again after stopping, check the oil level.

Shutdown of the Engine:

In case of emergency, turn the engine switch to the (off) position. Under normal circumstances, please follow the following steps to stop the engine:

- 1) Set the speed control handle to the low-speed position

Throttle Lever

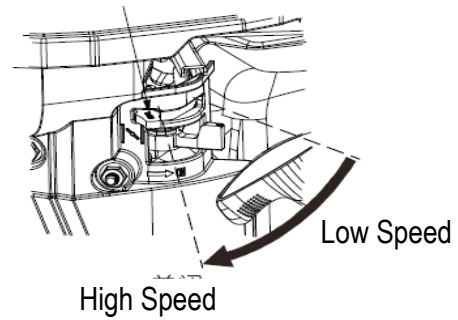

- 2) Turn the engine switch to the "OFF" position.

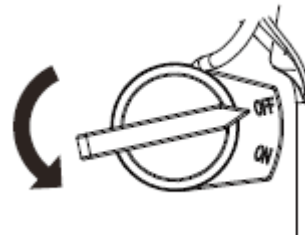

- 3) Turn the fuel switch to the "OFF" position.

Fuel switch

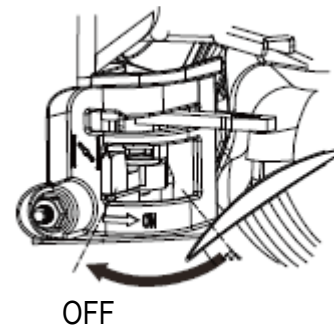

Maintenance

⚠ WARNING

Maintenance Hazards

ALWAYS turn off engine, and disconnect the spark plug wire before cleaning, adjusting, or servicing the engine. After servicing, make sure all guards and cover shields are replaced before using.

Maintenance Schedule Summary

Item	Maintenance period	Each use	First month or 20 hours	Every 3 months or 50 hours	Every 6 months or 200 hours	Every year or 300 hours
Engine oil	Check level	√				
	Change		√		√	
Air filter element	Inspection	√				
	Clean			√		
	Replace				√*	
Sediment cup	Clean				√*	
Spark plug	Replace					√**
Spark arrester	Clean				√*	
Idle	Check-adjust					√
Valve clearance	Check-adjust					√***
Fuel tank and fuel filter	Clean					√
Fuel hose	Inspection	Every 2 years (replace it if necessary)				
		<p>* Service more frequently when used in dusty environments.</p> <p>** If necessary.</p> <p>*** These items shall be maintained by a NorthStar Authorized Service Center unless the user has proper tools and maintenance capability.</p>				

Maintenance

No modifications. Never modify or alter the engine in any way. Modifications can create serious safety hazards and will also void the warranty.

Improper maintenance or failure to perform pre-operation checks before operation will result in malfunctions that could cause serious injury to you or others.

Follow Safety Rules

Read and follow these safety rules whenever you will be servicing the engine:

- **Turn off.** Always turn off before inspection or maintenance. Remove spark plug or spark plug wire to prevent accidental starting.
- **Fuel valve off.** Turn fuel shut-off valve to OFF position before transporting or servicing the engine.
- **Replace guards.** Make sure all guards and cover shields are replaced after servicing.
- **Major repair.** Major service, including the installation or replacement of parts, should be performed only by a qualified service technician. Obtain factory approved parts from NorthStar Product Support at 1-800-270-0810.
- **Replacement parts.** If a part needs replacement, only use factory approved repair parts. Replacement parts that do not meet specifications may result in a safety hazard or poor operation of the engine and will void the warranty.

Keep Engine Clean

If dust or debris accumulates on the engine, clean with a damp cloth or soft bristle brush. Do not allow air intakes to become blocked.

Improper maintenance or failure to perform pre-operation checks before operation will result in malfunctions that could cause serious injury to you or others.

Changing Engine Oil

WARNING

Burn Hazard

Never open oil port while engine is running. Hot oil can spray over face and body.

- 1) Drain the oil when the engine is warm to ensure quick and thorough draining
- 2) Unscrew the oil level gauge and oil drain bolt to drain the oil. Replace the oil drain bolt and tighten it.
- 3) Refill the recommended oil and check the oil level.
- 4) Reinstall the oil level gauge.

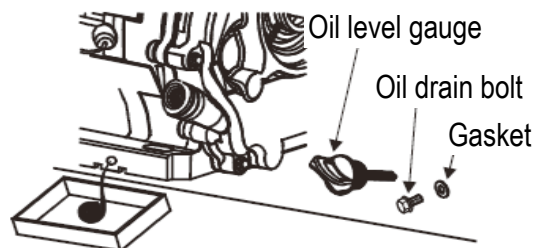

NOTICE:

Dispose of used motor and pump oil in a manner that is compatible with the environment and in accordance with local, state, and federal laws and regulations.

- Take used oil in a sealed container to your local recycling center or service station for reclamation.
- Do not throw it in the trash, pour it on the ground, or pour it down the drain.

DANGER

Carbon Monoxide Hazard

Exhaust fumes from the engine contain carbon monoxide (CO), a poisonous gas you cannot see, smell, or taste. The CO generated by the engine can rapidly accumulate, even in areas that appear to be well ventilated, resulting in dangerous and fatal concentrations within minutes. NEVER run engine inside any enclosed or semi-enclosed spaces, including homes, garages, basements, sheds, boxes, pick-up truck beds, RVs, or boats. These spaces can trap poisonous gases, EVEN if you run a fan or open windows. If you start to feel sick, dizzy, or weak while using the engine, shut off the engine and get to fresh air RIGHT AWAY. See a doctor. You may have carbon monoxide poisoning.

Maintenance

Air Filter Maintenance

A dirty air filter may restrict air from entering the carburetor. To prevent carburetor failure, the air filter should be maintained regularly. If the engine is operated in a dusty place, it needs to be maintained more frequently.

⚠ WARNING

Never use fuel or a solvent with a low ignition point to clean the air filter element, doing so may cause explosion. Please clean the element with warm soapy water or non-flammable solvents.

CAUTION

Never run the engine without the air filter and cover installed or damage to the engine could result. Damage to the engine by not having the air filter and cover installed is not covered under warranty.

- 1) Remove the air filter cover and filter element assembly.
- 2) Carefully separate the foam filter element from the Paper filter element assembly.
 - a. Paper filter element: Remove the dust by tapping the filter element several times on a hard surface or use compressed air from inside out.
 - b. Foam filter element: Wash it with warm, soapy water, then dry it. Soak it in the clean engine oil and squeeze out the excess oil. If too much oil remains in the foam filter element, there will be smoke coming out from the engine in the initial startup stage.

- 3) Clean off dust on the air filter cover and inner surface with a wet rag. Be careful not to allow dust to enter the carburetor.
- 4) Install the filter element assembly and the air filter cover.

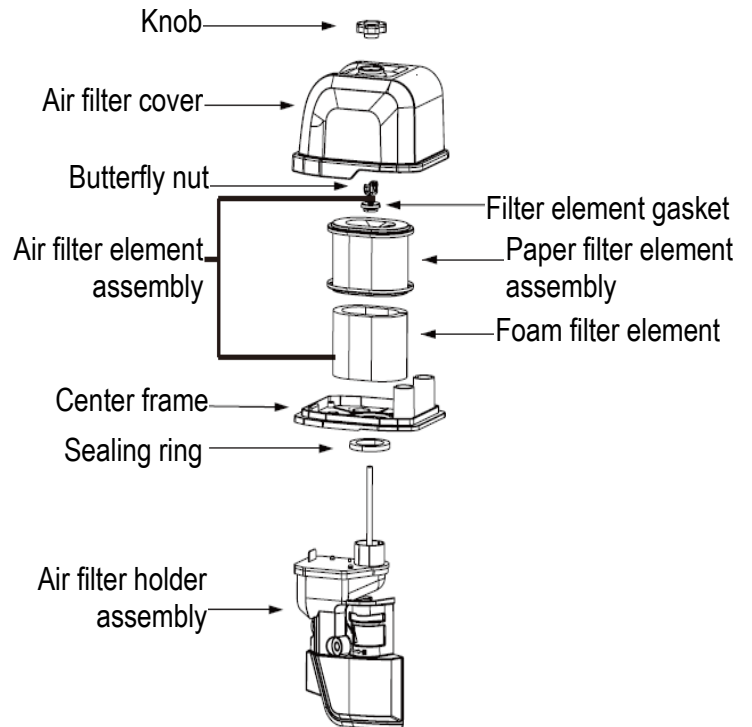

Maintenance

Spark Plug Maintenance

To ensure proper operation of the engine, the spark plugs must be provided with proper clearance and are free of deposits.

- 1) Remove the spark plug wire.
- 2) Clean the dirt around the spark plug holder.
- 3) Remove the spark plug with a spark plug socket wrench.
- 4) Visually inspect the spark plug. If its insulator is damaged, replace it with a new one. If the spark plug can still be used, clean it with a wire brush.
- 5) Measure the spark plug gap.

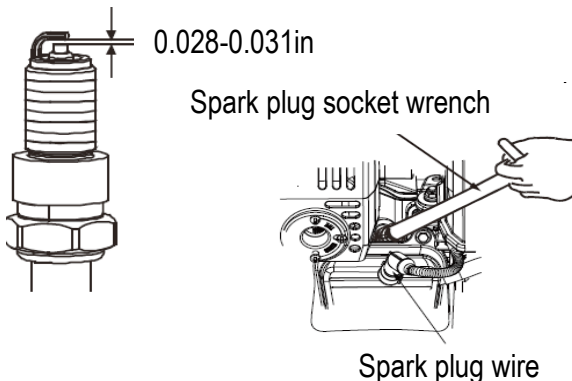

- 6) To prevent misalignment of the threads, screw the spark plug into the screw hole by hand.
- 7) After the spark plug is screwed to the end, tighten it with a special socket.
 - a) To install a new spark plug, the user should replace it according to the original spark plug type. Thread the spark plug into the engine until hand tight, then an additionally 1/2 turn (after hand tight).
 - b) If a used spark plug is reinstalled, thread the spark plug into the engine until hand tight, then an additionally 1/8-1/4 turn (after hand tight).

CAUTION

The spark plug must be tightened properly, or it may be extremely hot and damage the engine.

High Altitude Operation

CAUTION: Operating at an altitude of greater than 3000 feet (914 meters) may affect your engines performance, fuel consumption, and emissions. To remain emissions compliant and improve engine performance at higher altitudes, a high-altitude kit is required. A high altitude kit includes a carburetor jet resized to help correct air / fuel mixture at altitude. To order a high altitude kit or if you have additional questions, go to www.northerntool.com or contact us at 1-800-270-0810. Please note, engines with the high-altitude kit installed operated at lower altitudes could cause severe engine damage and affect emissions compliance. When modified, a tag or decal should be added to the product stating that a high-altitude kit was installed and to remind you to re-service the carburetor (re-jet) when operating in lower altitude environments.

Storage

Prepare Engine for Long Term Storage

First prepare the engine for long term storage if you will not be using it for more than 30 days.

Fuel can become stale when stored over 30 days. Stale fuel causes acid and gum deposits to form in the fuel system which can cause malfunction of the engine.

1. Prepare fuel system for storage:

- **Drain all gasoline** from the tank and carburetor. This is most easily accomplished by *running the engine* until the engine stops from lack of fuel. Drain carburetor bowl after engine has stopped and has been allowed to cool for at least two minutes.

OR

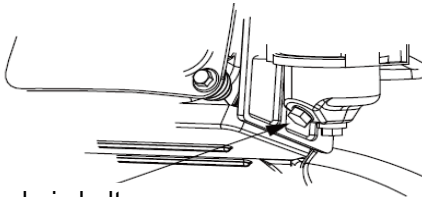

Carburetor drain bolt

- **Add fuel stabilizer** to the gasoline (following manufacturer's instructions)

Fuel stabilizer steps:

- Ensure gas tank is full.
 - Add fuel stabilizer to fuel tank.
 - Run engine* at least 5 minutes after adding stabilizer to allow it to enter the fuel system.
 - Shut off engine.
2. Lubricate cylinder and piston:
- Disconnect spark plug wire and remove spark plug.

- Add one teaspoon oil through spark plug hole.
- Place rag over spark plug hole and slowly pull the recoil a few times to lubricate the combustion chamber.

Replace spark plug, but do not reconnect the spark plug wire.

Move engine to Storage Location

Let engine cool for 5 minutes before moving the engine to its storage location.

! WARNING

Fuel Fire/Explosion Hazard

Gasoline is highly flammable and explosive. Heat, sparks, and flames can ignite fuel vapors, which can become widespread during fueling. A flash fire and/or explosion could result and cause serious injury or death. Always use extreme care when handling fuels. Carefully follow all instructions to avoid the following conditions which could result in fuel ignition:

- gas vapor collection inside enclosures
- static electric sparks
- sparks from electric wiring, batteries, or running engines
- sources of heat (such as a hot engine exhaust)
- open flames, including pilot lights

Troubleshooting

COMMON REASONS ENGINE WILL NOT START	
Causes	Solutions
Low oil shutdown	Fill engine with the adequate amount of oil
Cold engine	Choke engine to start
No fuel	Add gas to fuel tank. Make sure fuel shutoff valve is open
Engine not turned ON	Place ON/OFF switch in the ON position
Spark plug wire not attached	Attach spark plug wire to spark plug

Troubleshooting flow chart for failure to start the gasoline engine:

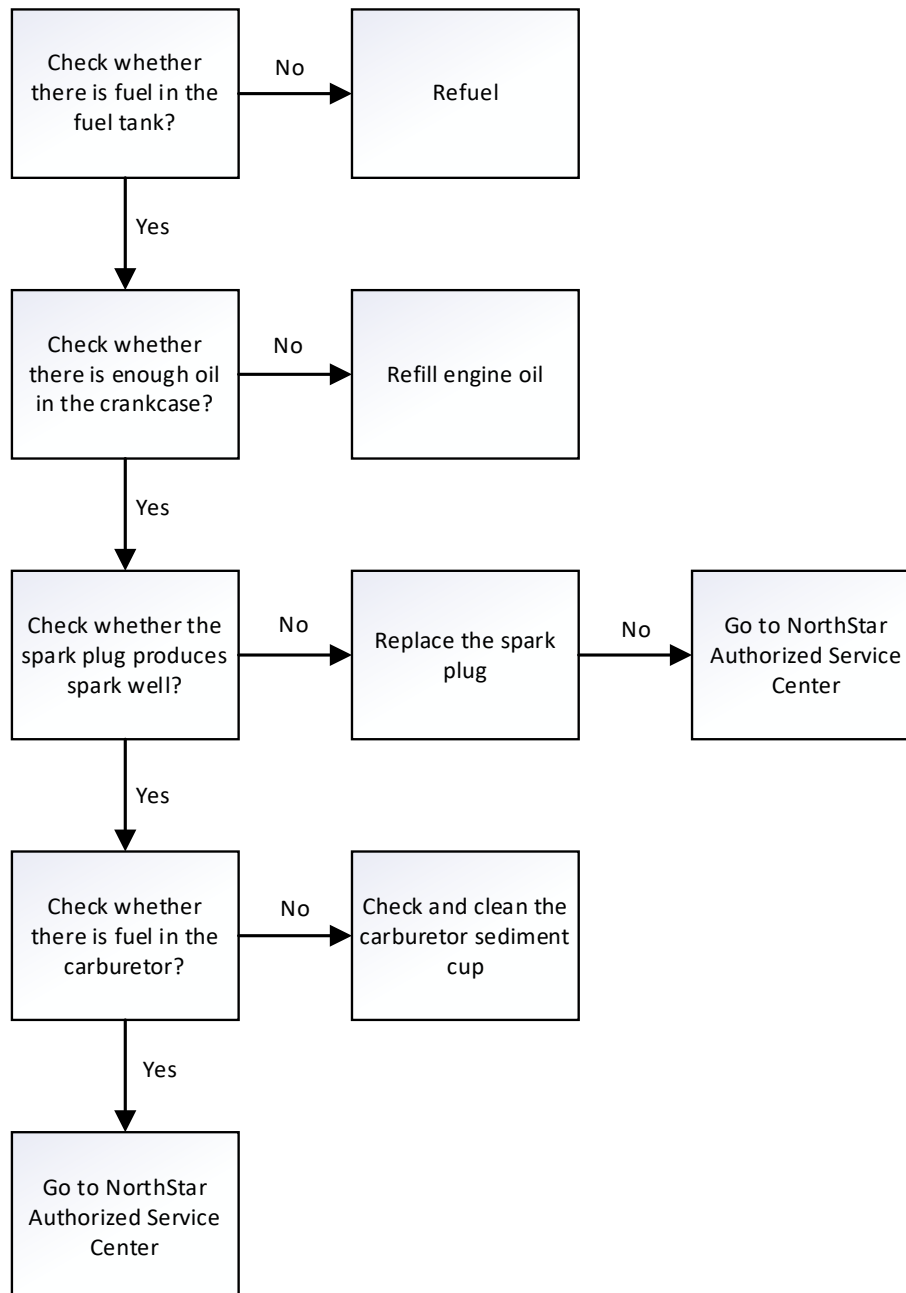

Item 114654 (804311) - c180 Engine Parts Explosion – Rev A.6

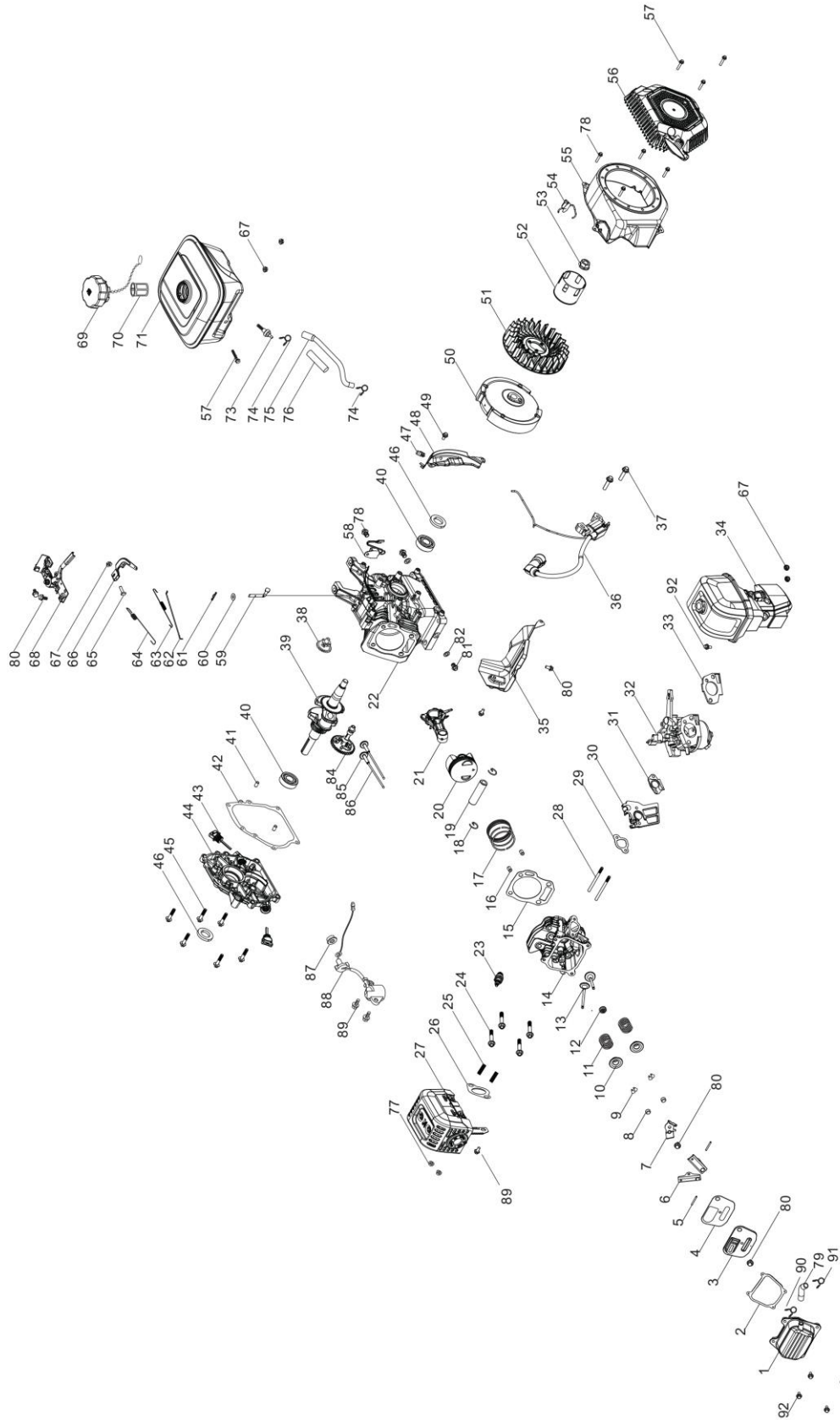



Item 114654 (804311) - c180 Engine Parts Explosion – Rev A.6

REF#	PART #	DESCRIPTION	QTY
1	Kit# 7, 8	COVER SUBASSEMBLY, CYLINDER HEAD	1
2	Kit# 3, 7, 8	CYLINDER HEAD COVER GASKET	1
3	Kit# 7, 8	STOP ENGINE PIECE SUBASSEMBLY	1
4	Kit# 3, 7, 8	GASKET, BREATH GROOVE	1
5	Kit# 6	SHAFT SUBASSEMBLY, ROCKER	2
6	Kit# 6	ROCKER SUBASSEMBLY, VALVE	2
7	Kit# 6	CYLINDER HEAD COVER PIN LIMIT PLATE	1
8	Kit# 6	ROTATOR, VALVE	2
9	Kit# 6	CLAMP, VALVE LOCK	4
10	Kit# 6	SEAT, VALVE SPRING	2
11	Kit# 6	SPRING, VALVE	2
12	Kit# 6	GUIDE, SEAL	1
13	Kit# 6	VALVES SET	1
14	Kit# 8	HEAD SUBASSEMBLY, CYLINDER	1
15	Kit# 3, 8	COVER SUBASSEMBLY, CYLINDER HEAD	1
16	Kit# 8	CYLINDER HEAD COVER GASKET	2
17	N/A	STOP ENGINE PIECE SUBASSEMBLY	1
18	N/A	GASKET, BREATH GROOVE	2
19	N/A	SHAFT SUBASSEMBLY, ROCKER	1
20	N/A	ROCKER SUBASSEMBLY, VALVE	1
21	N/A	CYLINDER HEAD COVER PIN LIMIT PLATE	1
22	N/A	ROTATOR, VALVE	1
23	Kit# 8, 9	PLUG, SPARK	1
24	Kit# 8	SEAT, VALVE SPRING M8 X 1 X 60	4
25	Kit# 8	SPRING, VALVE M8 X 1.25 X 34	2
26	Kit# 2, 3	GUIDE, SEAL	1
27	Kit# 2	VALVES SET	1
28	Kit# 8	HEAD SUBASSEMBLY, CYLINDER M6 X 1 X113	2
29	Kit# 3, 4	GASKET, CARBURETOR INSULATOR	1
30	Kit# 4	PLATE, CARBURETOR INSULATOR	1
31	Kit# 3, 4	CARBURETOR SEAL GASKET	1
32	Kit# 4	CARBURETOR ASSY.	1
33	Kit# 3, 4	AIR CLEANER SEAL GASKET	1
34	Kit# 1	AIR CLEANER	1
34a	Kit# 1, 9 or 805412	AIR FILTER ELEMENT	1
35	Kit# 5	SHROUD, CYLINDER BODY	1
36	Kit# 15	COIL, IGNITION	1
37	Kit# 15	HEXAGON SOCKET FLANGE FACE BOLT - SMALL SERIES M6 X 1 X 25	2
38	N/A	GEAR ASSY, GOVERNOR	1
39	N/A	CRANKSHAFT ASSY.	1
40	N/A	DEEP GROOVE BALL BEARING - P53	2
41	N/A	POSITION PIN - TYPE A	2
42	Kit# 3	GASKET, CRANKCASE	1
43	Kit# 17	DIPSTICK SUBASSEMBLY, OIL	2
44	N/A	COVER, CRANKCASE	1
45	N/A	HEXAGON SOCKET FLANGE FACE BOLT - SMALL SERIES M8 X 1.25 X 32	6
46	N/A	SEAL, OIL	2
47	Kit# 5	WIRE CLIP	1
48	Kit# 5	SHIELD, LOWER	1
49	Kit# 5	HEXAGON SOCKET FLANGE FACE BOLT - SMALL SERIES M6 X 1 X 26	1
50	805413	FLYWHEEL SUBASSEMBLY	1
51	Kit# 16	IMPELLER	1

Item 114654 (804311) - c180 Engine Parts Explosion – Rev A.6

52	Kit# 16	PULLEY, STARTER	1
53	Kit# 16	NUT, FLYWHEEL (HEXAGON) M14	1
54	Kit# 5	SWITCH SUBASSEMBLY, STOP ENGINE	1
55	Kit# 5	SHROUD	1
56	Kit# 11	STARTER ASSY, RECOIL	1
57	Kit# 11, 12	HEXAGON SOCKET FLANGE FACE BOLT-BIG SERIES-GRADE B M6X1X30	4
58	N/A	PROTECTOR, OIL	1
59	N/A	ARM, GOVERNOR	1
60	N/A	FLAT WASHER - GRADE A	1
61	N/A	COTTER PIN	1
62	Kit# 13	ROD, GOVERNEOR	1
63	Kit# 13	SPRING, THROTTLE VALVE RETURNING	1
64	Kit# 13	SPRING, GOVERNOR	1
65	Kit# 13	BOLT, GOVERNOR SUPPORT (Square Head) M6 X 1 X 21	1
66	Kit# 13	GOVERNOR BRACKET SUBASSEMBLY	1
67	Kit# 1, 12, 13	HEXAGON NUT WITH FLANGE M6	5
68	Kit# 13	CONTROL ASSY, THROTTLE	1
69	Kit# 12, 14	COVER, FUEL TANK	1
70	Kit# 9, 12, 14	STRAINER, FUEL	1
71	Kit# 12	FUEL TANK	1
73	Kit# 12	OUTLET SUBASSEMBLY, FUEL TANK OIL	1
74	Kit# 12	PIPE CLAMP	2
75	Kit# 12	TUBE, FUEL	1
76	Kit# 12	JACKET, RUBBER	1
77	Kit# 2	HEXAGON NUT M8	2
78	Kit# 5	HEXAGON SOCKET FLANGE FACE BOLT - SMALL SERIES M6 X 1 X 12	5
79	Kit# 7	TUBE, BREATHER	1
80	Kit# 5, 6, 7, 13	HEXAGON SOCKET FLANGE FACE BOLT - SMALL SERIES M6 X 1 X 10	6
81	805414	BOLT, DRAIN PLUG (HEXAGON HEAD) M10 X 1.25 X 15	2
82	N/A	FLAT WASHER - GRADE A	2
84	Kit# 6	CAMSHAFT ASSY.	1
85	Kit# 6	TAPPET, VALVE	2
86	Kit# 6	LIFTER, VALVE	2
87	Kit# 10	HEXAGON NUT WITH FLANGE m10	1
88	Kit# 10	SENSOR, ENGINE OIL	1
89	Kit# 2, 10	HEXAGON SOCKET FLANGE FACE BOLT - SMALL SERIES M6 X 1 X 14	3
90	N/A	COLLAR	1
91	Kit# 7	COLLAR	1
92	Kit# 1, 7	HEXAGON SOCKET FLANGE FACE BOLT - SMALL SERIES M6 X 1 X 20	5

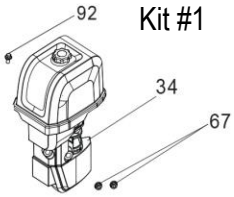
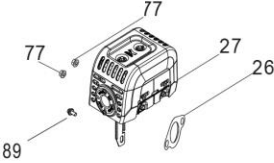
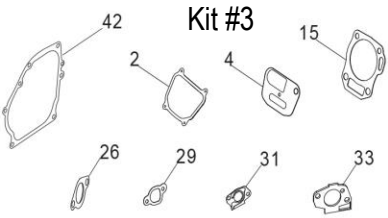
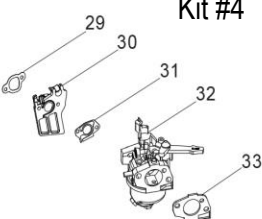
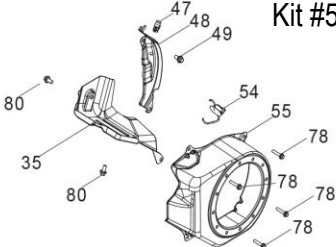
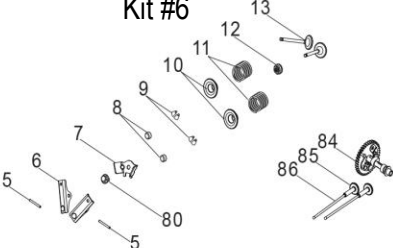
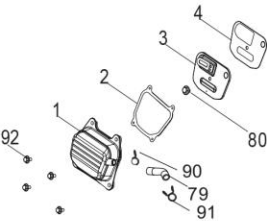
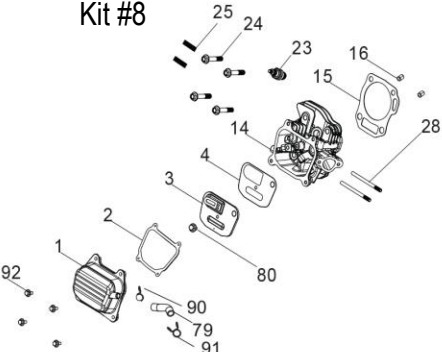
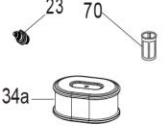
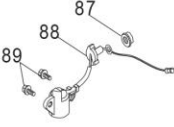
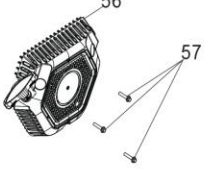
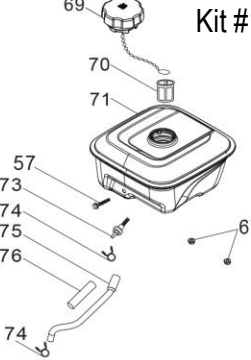
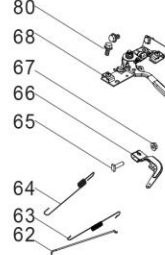
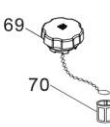
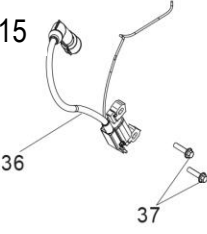
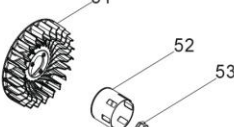
Item 114654 (804311) - c180 Engine Parts Kits – Rev A.6

<p>Kit #1</p> 	<p>Kit #2</p> 	<p>Kit #3</p> 	
<p>Kit #4</p> 	<p>Kit #5</p> 	<p>Kit #6</p> 	
<p>Kit #7</p> 	<p>Kit #8</p> 		<p>Kit #9</p> 
<p>Kit #10</p> 	<p>Kit #11</p> 	<p>Kit #12</p> 	<p>Kit #13</p> 
<p>Kit #14</p> 	<p>Kit #15</p> 	<p>Kit #16</p> 	<p>Kit #17</p> 

Item 114654 (804311) - c180 Engine Parts Kits – Rev A.6

KIT REF #	KIT PART #	DESCRIPTION	QTY
1	805069	AIR CLEANER KIT	1
2	805070	MUFFLER KIT	1
3	805071	GASKET KIT	1
4	805072	CARBURETOR KIT	1
5	805073	ENGINE SHROUD KIT	1
6	805074	ROCKER ARM AND VALVE KIT	1
7	805075	VALVE COVER KIT	1
8	805076	CYLINDER HEAD KIT	1
9	805077	MAINTENANCE KIT	1
10	805078	LOW OIL SENSOR KIT	1
11	805079	RECOIL STARTER KIT	1
12	805085	FUEL TANK KIT	1
13	805080	THROTTLE CONTROL ARM KIT	1
14	805084	FUEL CAP KIT	1
15	805081	IGNITION COIL KIT	1
16	805082	FLYWHEEL FAN AND CUP KIT	1
17	805083	OIL DIPSTICK KIT	1

Item 114655 (804312) - c225 Engine Parts Explosion – Rev A.6

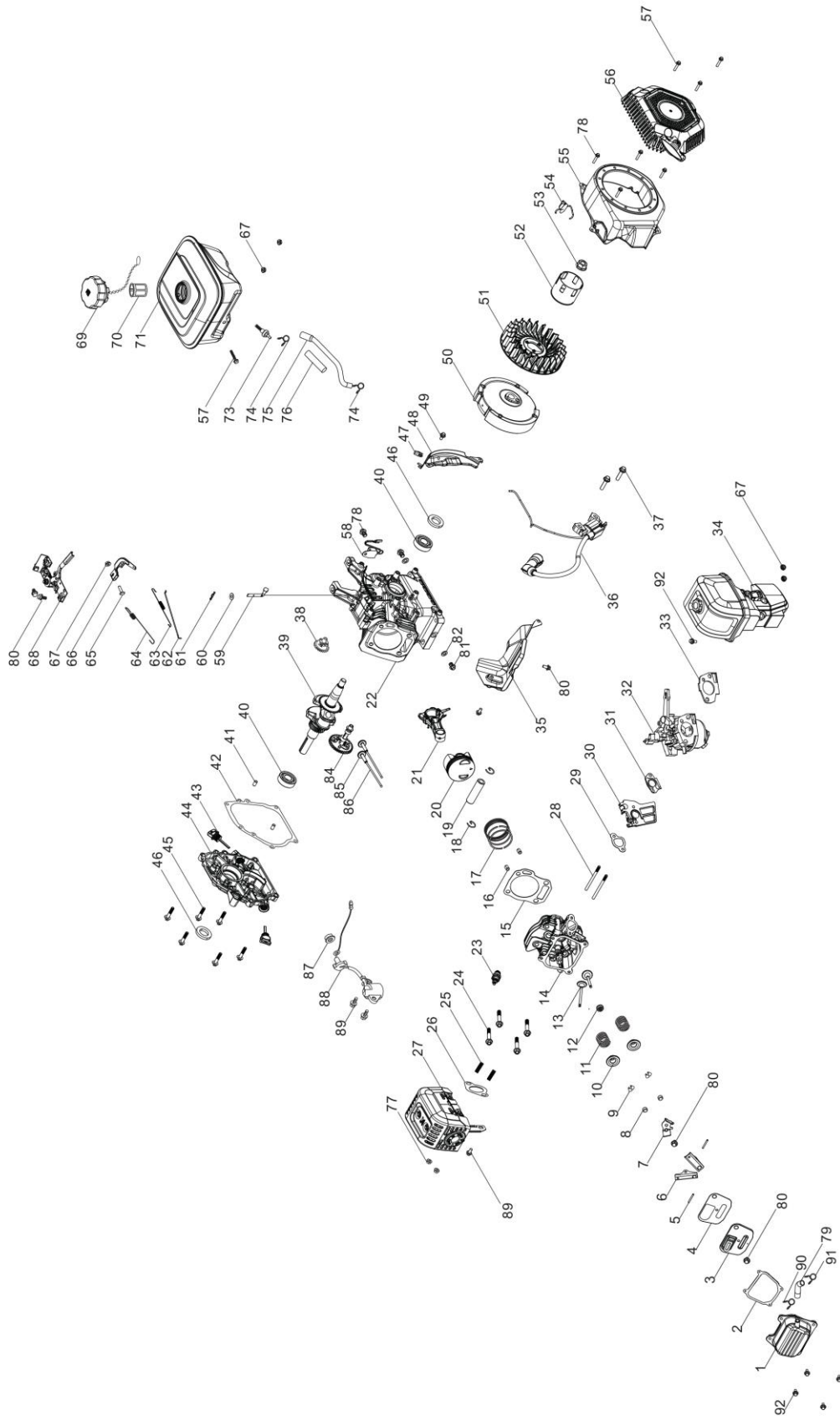

Item 114655 (804312) - c225 Engine Parts Explosion – Rev A.6

REF#	PART #	DESCRIPTION	QTY
1	Kit# 7, 8	COVER SUBASSEMBLY, CYLINDER HEAD	1
2	Kit# 3, 7, 8	CYLINDER HEAD COVER GASKET	1
3	Kit# 7, 8	STOP ENGINE PIECE SUBASSEMBLY	1
4	Kit# 3, 7, 8	GASKET, BREATH GROOVE	1
5	Kit# 6	SHAFT SUBASSEMBLY, ROCKER	2
6	Kit# 6	ROCKER SUBASSEMBLY, VALVE	2
7	Kit# 6	CYLINDER HEAD COVER PIN LIMIT PLATE	1
8	Kit# 6	ROTATOR, VALVE	2
9	Kit# 6	CLAMP, VALVE LOCK	4
10	Kit# 6	SEAT, VALVE SPRING	2
11	Kit# 6	SPRING, VALVE	2
12	Kit# 6	GUIDE, SEAL	1
13	Kit# 6	VALVES SET	1
14	Kit# 8	HEAD SUBASSEMBLY, CYLINDER	1
15	Kit# 3, 8	GASKET, CYLINDER HEAD	1
16	Kit# 8	POSITION PIN - TYPE A	2
17	N/A	RING ASSY, PISTON	1
18	N/A	CLIP, PISTON PIN	2
19	N/A	PIN, PISTON	1
20	N/A	PISTON	1
21	N/A	ROD, CONNECTING	1
22	N/A	CRANKCASE SUBASSEMBLY.	1
23	Kit# 8, 9	PLUG, SPARK	1
24	Kit# 8	CYLINDER HEAD BOLT (HEXAGON) M8 X 1 X 60	4
25	Kit# 8	STUD BOLT (BM=1.5D) M8 X 1.25 X 34	2
26	Kit# 2, 3	GASKET, EXHAUST OUTLET	1
27	Kit# 2	MUFFLER ASSY.	1
28	Kit# 8	STUD BOLT (BM=2D) M6 X 1 X 113	2
29	Kit# 3, 4	GASKET, CARBURETOR INSULATOR	1
30	Kit# 4	PLATE, CARBURETOR INSULATOR	1
31	Kit# 3, 4	CARBURETOR SEAL GASKET	1
32	Kit# 4	CARBURETOR ASSY.	1
33	Kit# 3, 4	AIR CLEANER SEAL GASKET	1
34	Kit# 1	AIR CLEANER	1
34a	Kit# 1, 9 or 805412	AIR FILTER ELEMENT	1
35	Kit# 5	SHROUD, CYLINDER BODY	1
36	Kit# 15	COIL, IGNITION	1
37	Kit# 15	HEXAGON SOCKET FLANGE FACE BOLT - SMALL SERIES M6 X 1 X 25	2
38	N/A	GEAR ASSY, GOVERNOR	1
39	N/A	CRANKSHAFT ASSY.	1
40	N/A	DEEP GROOVE BALL BEARING - P53	2
41	N/A	POSITION PIN - TYPE A	2
42	Kit# 3	GASKET, CRANKCASE	1
43	Kit# 17	DIPSTICK SUBASSEMBLY, OIL	2
44	N/A	COVER, CRANKCASE	1
45	N/A	HEXAGON SOCKET FLANGE FACE BOLT M8 X 1.25 X 32	6
46	N/A	SEAL, OIL	2
47	Kit# 5	WIRE CLIP	1
48	Kit# 5	SHIELD, LOWER	1
49	Kit# 5	HEXAGON SOCKET FLANGE FACE BOLT - SMALL SERIES M6 X 1 X 26	1

Item 114655 (804312) - c225 Engine Parts Explosion – Rev A.6

50	805413	FLYWHEEL SUBASSEMBLY	1
51	Kit# 16	IMPELLER	1
52	Kit# 16	PULLEY, STARTER	1
53	Kit# 16	NUT, FLYWHEEL (HEXAGON) M14	1
54	Kit# 5	SWITCH SUBASSEMBLY, STOP ENGINE	1
55	Kit# 5	SHROUD	1
56	Kit# 11	STARTER ASSY, RECOIL	1
57	Kit# 11, 12	HEXAGON SOCKET FLANGE FACE BOLT BIG SERIES-GRADE B M6X1X30	4
58	N/A	PROTECTOR, OIL	1
59	N/A	ARM, GOVERNOR	1
60	N/A	FLAT WASHER - GRADE A	1
61	N/A	COTTER PIN	1
62	Kit# 13	ROD, GOVERNEOR	1
63	Kit# 13	SPRING, THROTTLE VALVE RETURNING	1
64	Kit# 13	SPRING, GOVERNOR	1
65	Kit# 13	BOLT, GOVERNOR SUPPORT (Square) M6 X 1 X 21	1
66	Kit# 13	GOVERNOR BRACKET SUBASSEMBLY	1
67	Kit# 1, 12, 13	HEXAGON NUT WITH FLANGE M6	5
68	Kit# 13	CONTROL ASSY, THROTTLE	1
69	Kit# 12, 14	COVER, FUEL TANK	1
70	Kit# 9, 12, 14	STRAINER, FUEL	1
71	Kit# 12	FUEL TANK	1
73	Kit# 12	OUTLET SUBASSEMBLY, FUEL TANK OIL	1
74	Kit# 12	PIPE CLAMP	2
75	Kit# 12	TUBE, FUEL	1
76	Kit# 12	JACKET, RUBBER	1
77	Kit# 2	HEXAGON NUT M8	2
78	Kit# 5	HEXAGON SOCKET FLANGE FACE BOLT - SMALL SERIES M6 X 1 X 12	5
79	Kit# 7	TUBE, BREATHER	1
80	Kit# 5, 6, 7, 13	HEXAGON SOCKET FLANGE FACE BOLT - SMALL SERIES M6 X 1 X 10	6
81	805414	BOLT, DRAIN PLUG (HEXAGON) M10 X 1.25 X 15	2
82	N/A	FLAT WASHER - GRADE A	2
84	Kit# 6	CAMSHAFT ASSY.	1
85	Kit# 6	TAPPET, VALVE	2
86	Kit# 6	LIFTER, VALVE	2
87	Kit# 10	HEXAGON NUT WITH FLANGE M10	1
88	Kit# 10	SENSOR, ENGINE OIL	1
89	Kit# 2, 10	HEXAGON SOCKET FLANGE FACE BOLT - SMALL SERIES M6 X 1 X 14	3
90	N/A	COLLAR	1
91	Kit# 7	COLLAR	1
92	Kit# 1, 7	HEXAGON SOCKET FLANGE FACE BOLT - SMALL SERIES M6 X 1 X 20	5

Item 114655 (804312) - c225 Engine Parts Kits – Rev A.6

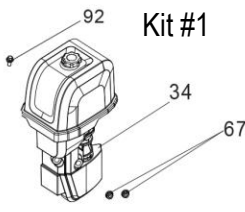
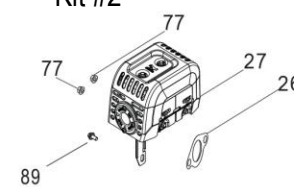
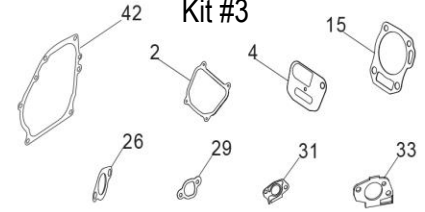
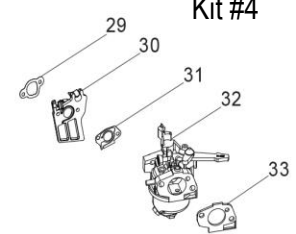
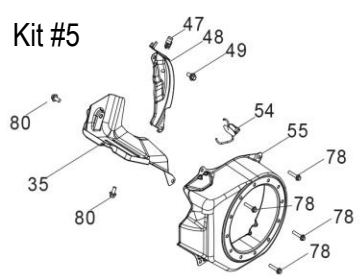
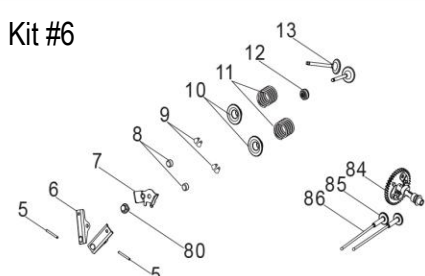
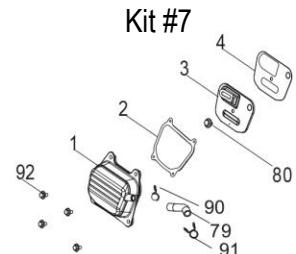
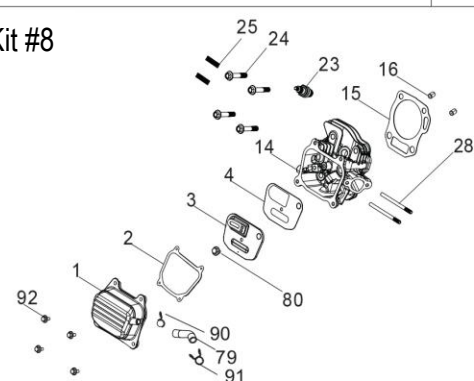
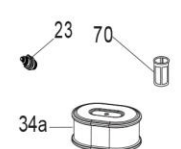
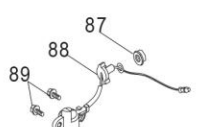
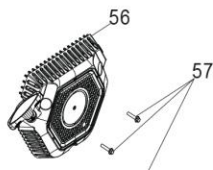
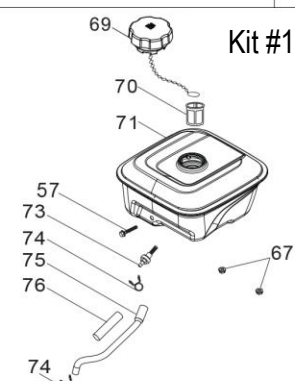
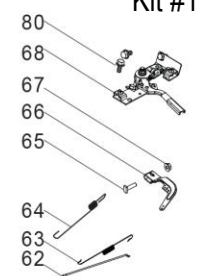
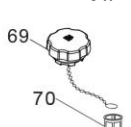
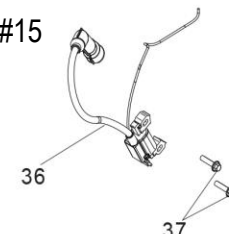
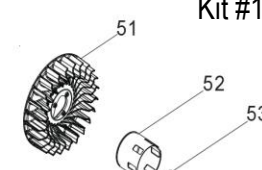
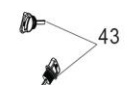
<p style="text-align: center;">Kit #1</p> 	<p style="text-align: center;">Kit #2</p> 	<p style="text-align: center;">Kit #3</p> 	
<p style="text-align: center;">Kit #4</p> 	<p style="text-align: center;">Kit #5</p> 	<p style="text-align: center;">Kit #6</p> 	
<p style="text-align: center;">Kit #7</p> 	<p style="text-align: center;">Kit #8</p> 	<p style="text-align: center;">Kit #9</p> 	
<p style="text-align: center;">Kit #10</p> 	<p style="text-align: center;">Kit #11</p> 	<p style="text-align: center;">Kit #12</p> 	<p style="text-align: center;">Kit #13</p> 
<p style="text-align: center;">Kit #14</p> 	<p style="text-align: center;">Kit #15</p> 	<p style="text-align: center;">Kit #16</p> 	<p style="text-align: center;">Kit #17</p> 

Item 114655 (804312) - c225 Engine Parts Kits – Rev A.6

KIT REF #	KIT PART #	DESCRIPTION	QTY
1	805415	AIR CLEANER KIT	1
2	805070	MUFFLER KIT	1
3	805086	GASKET KIT	1
4	805087	CARBURETOR KIT	1
5	805073	ENGINE SHROUD KIT	1
6	805088	ROCKER ARM AND VALVE KIT	1
7	805075	VALVE COVER KIT	1
8	805089	CYLINDER HEAD KIT	1
9	805077	MAINTENANCE KIT	1
10	805078	LOW OIL SENSOR KIT	1
11	805079	RECOIL STARTER KIT	1
12	805085	FUEL TANK KIT	1
13	805090	THROTTLE CONTROL ARM KIT	1
14	805084	FUEL CAP KIT	1
15	805081	IGNITION COIL KIT	1
16	805082	FLYWHEEL FAN AND CUP KIT	1
17	805083	OIL DIPSTICK KIT	1

Electrical Schematic Diagram

Recoil start, with low oil switch.

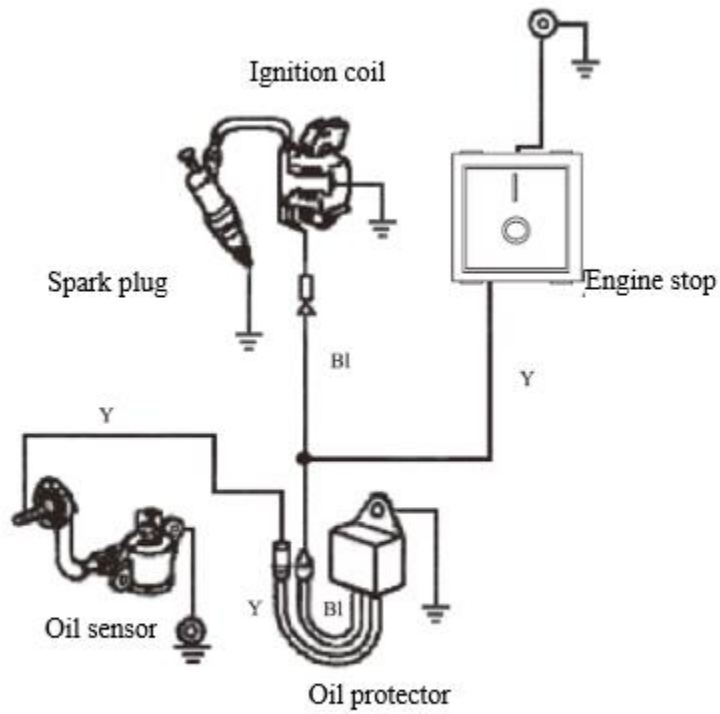

Limited Warranty

Dear Valued Customer:

The NorthStar Product you just purchased is built with the finest material and craftsmanship. Use this product properly and enjoy the benefits from its high performance. By purchasing a NorthStar product, you show a desire for quality and durability. Treat this engine like the high-quality piece of machinery it is. Neglect and improper handling may impair its performance. Please thoroughly read the instructions and understand the operation before using your product. Always contact NorthStar Product Support at 1-800-270-0810 prior to having any service or warranty work performed, as some services performed by parties other than NorthStar approved service centers may void this warranty. This warranty is in lieu of any other warranty expressed or implied and NorthStar assumes no other responsibility or liability outside that expressed within this warranty.

Limited Warranty

NorthStar shall warranty any piece of equipment manufactured, or parts of equipment manufactured, to be free from defects in material or workmanship for a period of:

Item Number	Item Name	Commercial/Consumer Warranty	Details
114654, 114655	c180 c225	5 years from date of purchase	The engine warranty is covered under the terms and conditions as outlined by the NorthStar engine warranty and is the sole responsibility of NorthStar. Normal engine maintenance such as spark plugs, air filters, adjustments, fuel system cleaning and obstruction due to build up is not covered by this NorthStar warranty.

“Consumer use” means personal residential household use by a consumer. “Commercial use” means all other uses, including use for commercial, income producing or rental purposes or when purchased by a business.

This warranty applies to the original purchaser of the equipment (verification of purchase, in the form of a receipt, is the responsibility of the buyer), is non-transferable, and covers parts and labor. Parts will be replaced or repaired at no charge, except when the equipment has failed due to lack of proper maintenance. If a part is no longer available, the part may be replaced with a similar part of equal function. Any misuse, abuse, alteration or improper installation or operations will void warranty. Determining whether a part is to be replaced or repaired is the sole decision of NorthStar. NorthStar will not provide for replacement of complete products due to defective parts. Any costs incurred due to replacement or repair of items outside of a NorthStar approved facility is the responsibility of the buyer and not covered under warranty. Transportation costs to and from service center is the responsibility of the customer.

This warranty specifically excludes the following: failure of parts due to damage caused by accident, fire, flood, windstorm, acts of God, applications not approved by NorthStar in writing, corrosion caused by chemicals, use of replacement parts which do not conform to manufacturer’s specifications, damage related to rodent and/or insect infestation and damage caused by vandalism. Additional exclusions: loss of running time, inconvenience, loss of income, or loss of use, including any implied warranty of merchantability of fitness for a specific use. Also, Outdoor Power Equipment needs periodic parts and service to perform well, and this warranty does not cover instances when normal use has exhausted the life of a component or the engine.

This warranty does not cover any personal injury or damage to surrounding property caused by failure of any part. Repair or replacement of parts does not extend the warranty period.

The engine warranty is covered under the terms and conditions as outlined by the engine manufactures warranty contained herein and is the sole responsibility of the engine manufacture. Normal engine maintenance such as spark plugs, air filters, adjustments, fuel system cleaning and obstruction due to build up is not covered by this NorthStar warranty.

Please fill in the following information and have it on hand when you call in on a warranty claim.

Customer Number: _____

Date of Purchase: _____

NorthStar Serial Number: _____

Item Number: _____

Emission Control Warranty Statement

U.S EPA EMISSIONS CONTROL WARRANTY STATEMENT YOUR WARRANTY RIGHTS AND OBLIGATIONS

The U.S Environmental Protection Agency (EPA) and Northern Tool & Equipment Company Inc. are pleased to explain the emissions control system warranty on your 2024 and later small Non-Road Spark Ignition (NRSI) engines. Northern Tool & Equipment Company, Inc. must warrant the emissions control system on your NRSI engines for the periods of time listed below provided there has been no abuse, neglect or improper maintenance of your NRSI engines.

Your emission control system may include parts such as the carburetor, fuel tanks, fuel caps, fuel lines, the ignition system, and catalytic converter. Also included may be hoses, belts, S clamps, connectors and other emission-related assemblies.

Where a warrantable condition exists, Northern Tool & Equipment Company Inc. will repair your small off-road engine at no cost to you including diagnosis, parts and labor.

MANUFACTURER'S WARRANTY COVERAGE

The emissions control system is warranted for two years. If any emissions-related part on your engine is defective, the part will be repaired or replaced by Northern Tool & Equipment Company Inc.

OWNER'S WARRANTY RESPONSIBILITIES

As the NRSI ENGINE owner, you are responsible for the performance of the required maintenance listed in your owner's manual. Northern Tool & Equipment Company Inc. recommends that you retain all receipts covering maintenance on your NRSI ENGINE, but Northern Tool & Equipment Company Inc. cannot deny warranty solely for the lack of receipts or for your failure to ensure the performance of all scheduled maintenance.

As the NRSI ENGINE owner, you should however be aware that Northern Tool & Equipment Company Inc. may deny your warranty coverage if your NRSI ENGINE or a part has failed due to abuse, neglect, improper maintenance or unapproved modifications.

You are responsible for presenting your NRSI ENGINE to a distribution center or service center authorized by Northern Tool & Equipment Company Inc. as soon as the problem exists. The warranty repairs should be completed in a reasonable amount of time, not to exceed 30 days.

If you have any questions regarding your warranty coverage or how to locate a service center, you should contact Northern Tool & Equipment Company Inc. at:

Tell: 1-800-270-0810

Email: Customercare@northerntool.com

DEFECTS WARRANTY COVERAGE

Northern Tool & Equipment Company Inc. warrants to the ultimate purchaser and each subsequent purchaser that the small off-road engine (NRSI ENGINE) (1) has been designed, built and equipped so as to conform with all applicable regulations; and (2) is free from defects in materials and workmanship that cause the failure of a warranted part to conform with those regulations as may be applicable to the terms and conditions stated below.

(a) The warranty period begins on the date the engine is delivered to an ultimate purchaser or first placed into service. The warranty period is two years.

Emission Control Warranty Statement

- (1) Subject to certain conditions and exclusions as stated below, the warranty on emissions related parts is as follows:
- (2) Any warranted part that is not scheduled for replacement as required maintenance in your **Owner's Manual** is warranted for the warranty period stated above. If the part fails during the period of warranty coverage, the part will be repaired or replaced by Northern Tool & Equipment Company Inc. according to Subsection (d) below. Any such part repaired or replaced under warranty will be warranted for the remainder of the period.
- (3) Any warranted part that is scheduled only for regular inspection in your **Owner's Manual** is warranted for the warranty period stated above. Any such part repaired or replaced under warranty will be warranted for the remaining warranty period.
- (4) Any warranted part that is scheduled for replacement as required maintenance in your **Owner's Manual** is warranted for the period of time before the first scheduled replacement date for that part. If the part fails before the first scheduled replacement, the part will be repaired or replaced by Northern Tool & Equipment Company Inc. according to Subsection (d) below. Any such part repaired or replaced under warranty will be warranted for the remainder of the period prior to the first scheduled replacement point for the part.
- (5) Repair or replacement of any warranted part under the warranty provisions herein must be performed at a warranty station at no charge to the owner.
- (6) Notwithstanding the provisions herein, warranty services or repair will be provided at all of our distribution centers that are franchised to service the subject engines.
- (7) The engine owner must not be charged for diagnostic labor that leads to the determination that a warranted part is in fact defective, provided that such diagnostic work is performed at a warranty station.
- (8) Northern Tool & Equipment Company Inc. is liable for damages to other engine components proximately caused by a failure under warranty of any warranted part.
- (9) Throughout the engine warranty period stated above, Northern Tool & Equipment Company Inc. will maintain a supply of warranted parts sufficient to meet the expected demand for such parts.
- (10) Any replacement part may be used in the performance of any warranty maintenance or repairs and must be provided without charge to the owner. Such use will not reduce the warranty obligations of Northern Tool & Equipment Company Inc.
- (11) Add-on or modified parts that are not exempted by the U.S EPA may not be used. The use of any non-exempted add-on or modified parts by the ultimate purchaser will be grounds for disallowing a warranty claims. Northern Tool & Equipment Company Inc. will not be liable to warrant failures of warranted parts caused by the use of a non-exempted add-on or modified part.
- (12) The manufacturer issuing the warranty shall provide any documents that describe that manufacturer's warranty procedures or policies within five working days of request by the U.S EPA.

Emission Control Warranty Statement

EMISSION WARRANTY PARTS LIST

The repair or replacement of any warranted part otherwise eligible for warranty coverage may be excluded from such warranty coverage if Northern Tool & Equipment Company Inc. demonstrates that the engine has been abused, neglected, or improperly maintained, and that such abuse, neglect, or improper maintenance was the direct cause of the need for repair or replacement of the part. That notwithstanding, any adjustment of a component that has a factory installed, and properly operating, adjustment limiting device is still eligible for warranty coverage. The following emissions warranty parts for each engine family list is covered.

For exhaust emissions, emission-related components include any engine parts related to the following systems:

1. Fuel Metering System
 - a. Carburetor and internal parts (and/or pressure regulator or fuel injection systems).
 - b. Air/fuel ratio feedback and control system.
2. Air Induction System
 - b. Intake manifold.
 - c. Air filter
3. Ignition System
 - a. Spark Plugs.
 - b. Magneto or electronic ignition system.
6. Catalyst or Thermal Reactor System
 - c. Exhaust manifold.
8. Miscellaneous items Used in Above Systems
 - a. Vacuum, temperature, and time sensitive valves and switches.
 - b. Electronic controls.
 - c. Hoses, belts, connectors, and assemblies.

The following parts are considered emission-related components for evaporative emissions:

1. Fuel Tank.
2. Fuel Cap.
3. Fuel Line.
4. Fuel Line Fittings.
5. Clamps*.
8. Control Solenoids*.
9. Electronic Controls*.
14. Vapor Hoses.
16. Carbon Canister.
17. Canister Mounting Brackets (if equipped).

*As related to the evaporative emission control system.



Distributed by
Northern Tool & Equipment Company, Inc.
Burnsville, MN 55306
NorthernTool.com
Made in China