



Installation Instructions: DT3/DT4

TOYOTA TUNDRA

5'7" BED LENGTH

6'7" BED LENGTH

2022-CURRENT

TOOLS REQUIRED

- 3/8" socket
- 7/16" socket
- Wire cutters
- 1/8" hex wrench
- 7/32" hex wrench
- 1/2" drill bit
- T40 Torx driver



REGISTER YOUR SYSTEM



INSTRUCTION VIDEOS

Watch short installation videos at www.decked.com/video | Register your system at www.decked.com/warranty

FOLLOW US:      @DECKEDUSA | #DECKEDUSA

VERSION 8

DECKED.COM | 208.806.0251

RC923

CONTENTS

DECKED carton

- LEFT/DRIVER DECK HALF - 1
- RIGHT/PASSENGER DECK HALF - 1
- CENTER VERT - 1
- DRAWER - 2
- CABSIDE AMMO CAN - 2
- TAILGATE SIDE AMMO CAN - 2
- AMMO CAN LID - 4
- AMMO CAN WINDOW - 2
- C-CHANNEL - 2
- RULER - 1
- HARDWARE BOX - 1
- TORSION BRACE - 1
- BOTTLE OPENER - 1

Hardware box - unbagged components

(inside DECKED carton):

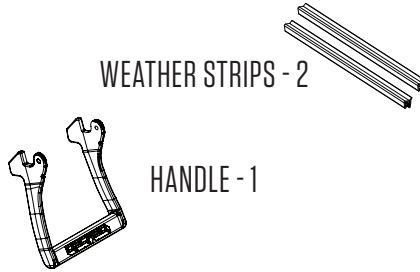

HARDWARE box - bagged components

- PREP DT3/DT4 - 1
- C-CHANNEL - 1
- BOLT 1 FS (B1) - 1
- GS AMMO CANS - 1
- J3 - 4
- DRAWER 1 - 1
- DRAWER 3 - 1
- HANDLE - 1
- WHEELS - 1
- PREP-EXTRA - 1
- WASHERS - 1
- PREP TBO - 1

ASSEMBLY OVERVIEW

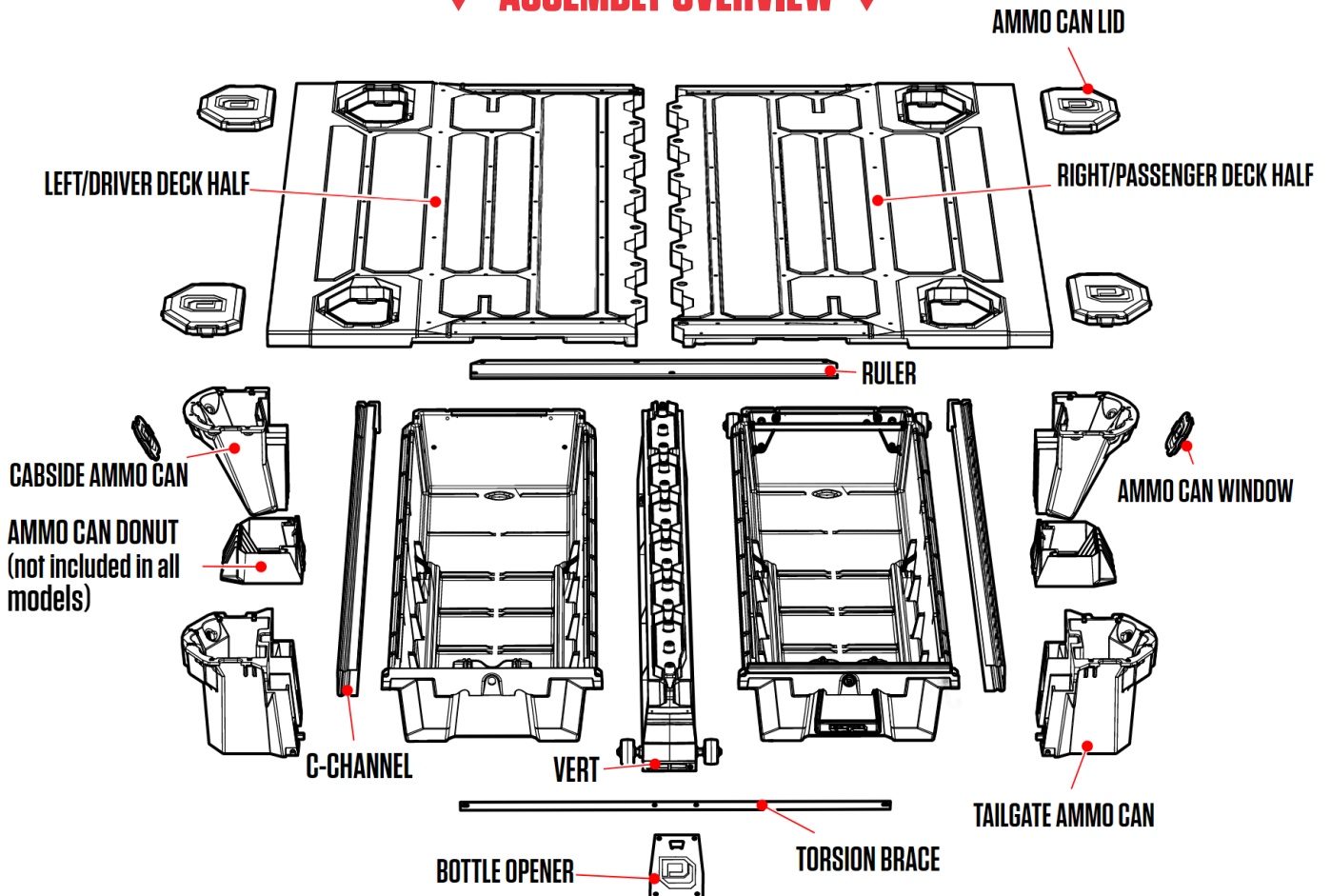

▼ HEY! TORQUE BOY: READ BEFORE YOU INSTALL DECKED ▼

1. **DON'T** go rogue on us, please read the instructions.
2. **DON'T** over tighten bolts, get em' hand-tight.
3. **DON'T** use power tools.
4. If you don't follow directions and *do* use power tools:
 - 1). Set clutch at a very low setting.
 - 2). If you blow it, see NOTE.*
5. Start all bolts with fingers to avoid cross-threading.
6. **DON'T** over tighten J-hooks during installation. Just get 'em good and snug; enough to keep the system from moving in the bed.
7. Nice job if you're still reading.

NOTE* Two extra threaded inserts are included in **BAG PREP-EXTRA**. That's all you get, unless you call us and ask for more. The inserts will replace any stripped inserts in the tailgate ammo cans or front face of the center vert at the bottle opener, but **NOT THE TOP OF THE CENTER VERT**, so hand tighten until snug only! You can also screw the inserts back in if dislocated. There is a straight screwdriver slot on the underside of the threaded insert.

TAILGATE ammo cans have wide bottoms; **CABSIDE** ammo cans have narrow bottoms.

NOTE: You will need a buddy to help with exactly two steps.

*Prevent embarrassing, expletive-filled language,
watch our detailed installation video or give us a call. We're happy to help!*

208.806.0251 | DECKED.COM/INSTALLVIDEO

AMMO CAN DRAIN HOLES

(TO DRILL OR NOT TO DRILL.)

• Do you use a tonneau or shell over your DECKED system?

There is no need to drill holes, unless you leave your tonneau open in a deluge.

• Does your DECKED system live outside?

The ammo cans will get water in them. You'll need to drill holes in the ammo cans.

There are two dimples in the bottom of each ammo can. Drill a 1/2" hole at each dimple. A smaller hole will get clogged.



PREP BED

(JUST LIKE YOUR MOMMA TAUGHT YOU.)

bag: PREP DT3-DT4

- Remove the cabside factory tie-downs on both sides of truck bed (T40 Torx driver required). Make sure to **SAVE THE FACTORY TUNDRA BOLTS**, as you will need them for the DECKED brackets. Detail B.
- Install DECKED tie-down brackets on both sides of truck using the Tundra bolts you removed.
- If you have a spray-on liner, you may have to remove the liner material from the Torx 40 bolts in order to remove them.

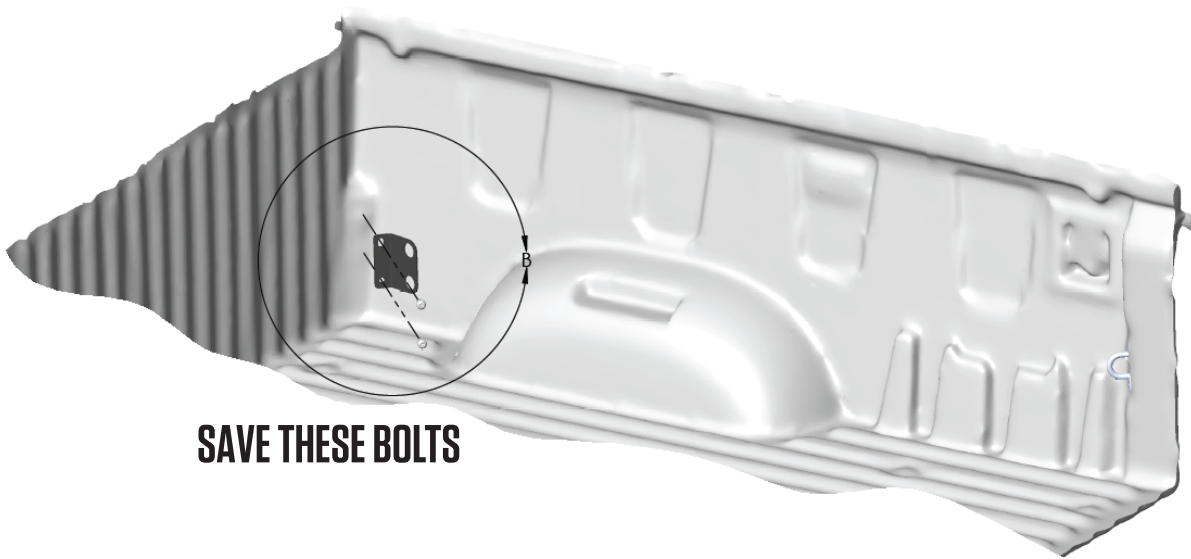

SAVE THESE BOLTS



REUSE TUNDRA BOLTS

DETAIL B
PREP DT3/DT4

RECOMMENDED TORQUE: 53 in-lb.

ASSEMBLY

(Now the fun begins!)

LAY IT OUT:

1. Install the cabside ammo can donuts onto the bottom of the cabside ammo cans (DT4 only).
2. Arrange all components on a flat surface as shown, not in your truck.
3. Make sure all wheel axles are on the tailgate side. Read this again. Don't mess this up.
4. Place the C-channels on the ledges of the ammo cans.
5. The C-channel end plates must be on the cabside of the assembly.

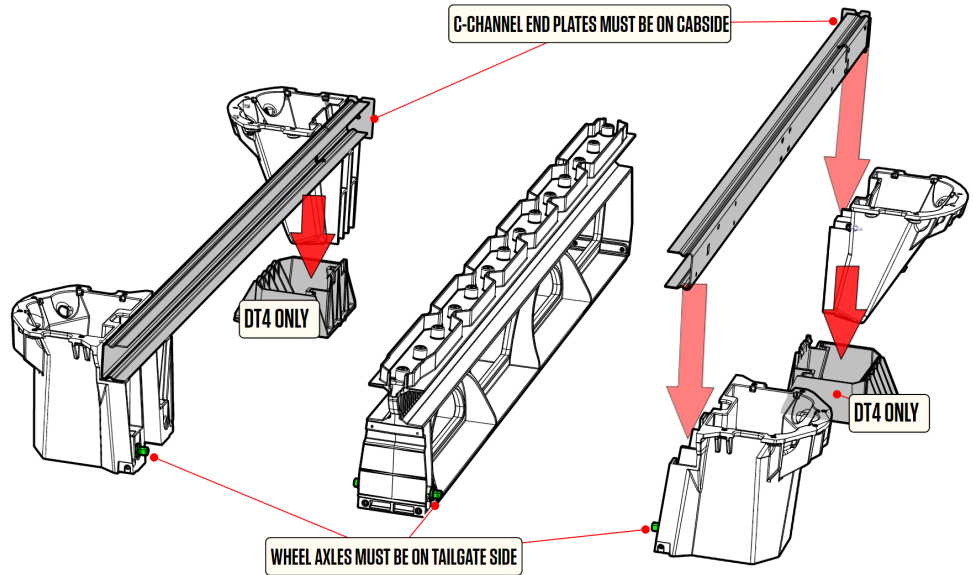

HOOK IT UP:

bags: WASHERS/C-CHANNEL

1. Install nylon washers (no rubber washers) onto all CS Ammo Can bolts.
2. Install through INSIDE of C-channel and into ammo can.
3. Fasten with flanged nut on inside of ammo can, but do not tighten.
4. Repeat same procedure for the other three ammo cans. Don't tighten.

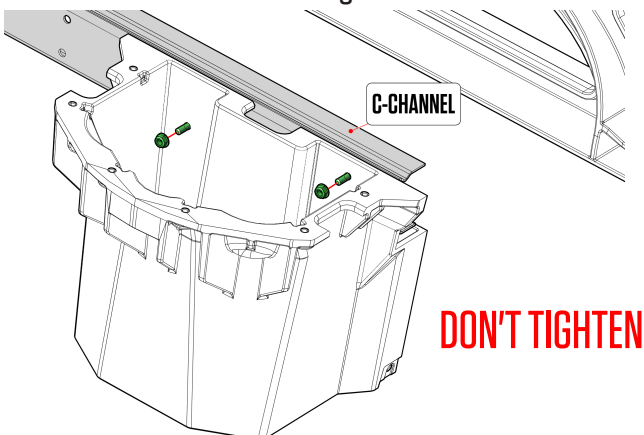
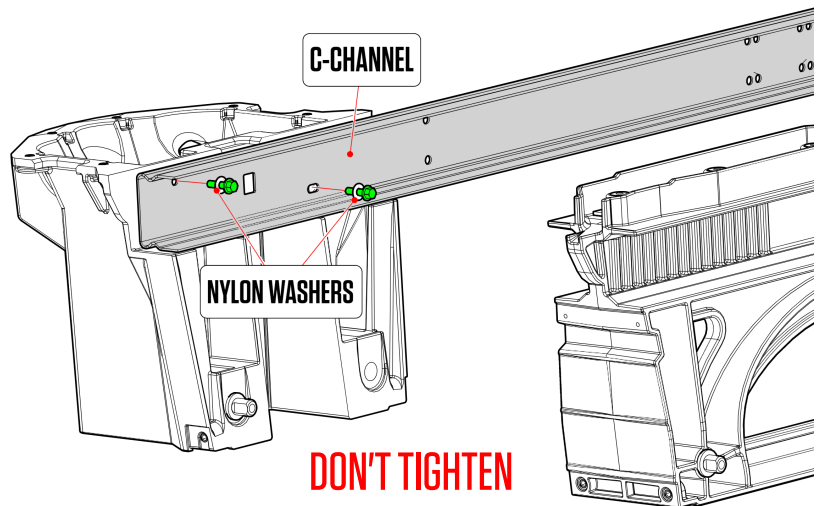

Note: 4 things you could have messed up:

1. C-channel bolt heads are inside ammo cans and not C-channels - wheels ain't gonna roll.
2. Wheel axles on ammo cans and vert aren't all the way at the tailgate side - wheels ain't gonna install in the correct spot.
3. C-channel end caps are on the tailgate side - things ain't gonna fit.
4. You tightened the C-channel to ammo can bolts when I told you not to.

GET YOUR DECK ON

LAY IT ON:

bags: WASHERS/CS AMMO CANS/BOLT 1 FS (B1)

1. Seat the passenger side deck on the vert and the ammo cans. You may have to move the ammo cans around a bit. The panel label must be on the TAILGATE side.
2. Install the white nylon washers on all CS AMMO CAN bolts then the black rubber washers. See DETAIL A.
3. Install nylon and rubber washers on 12 BOLT 1 FS (B1) bolts. See DETAIL A.
4. Use six (6) of the CS AMMO CAN bolts and flanged nuts to install the deck to the cabside ammo can. Tighten until snug. 27 in-lb.
5. Use six (6) of the B1 bolts with washers to install the deck to the tailgate ammo can - no nuts here. Tighten until just snug. 27 in-lb.
6. Use the B1 bolts with NO WASHERS to install the passenger side deck to the center vert.

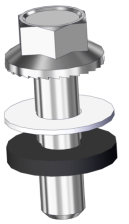
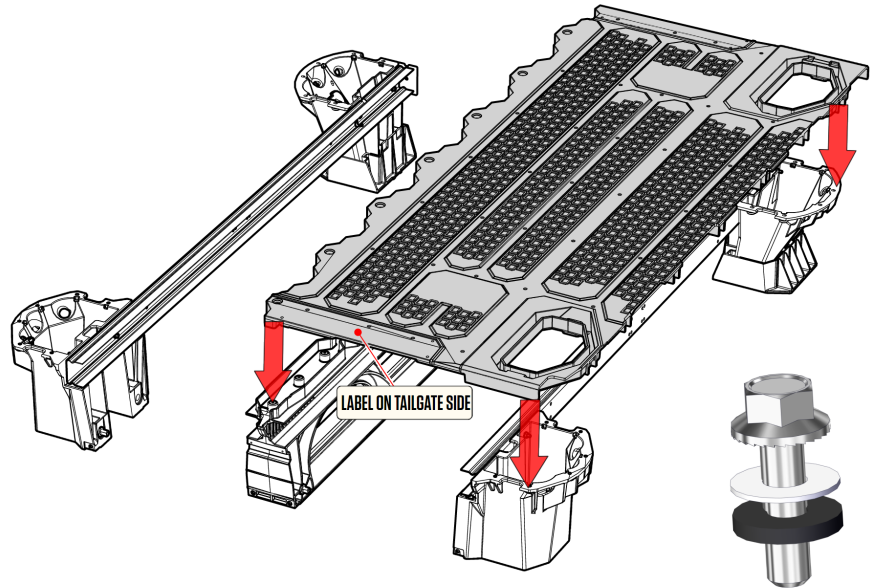

DETAIL A

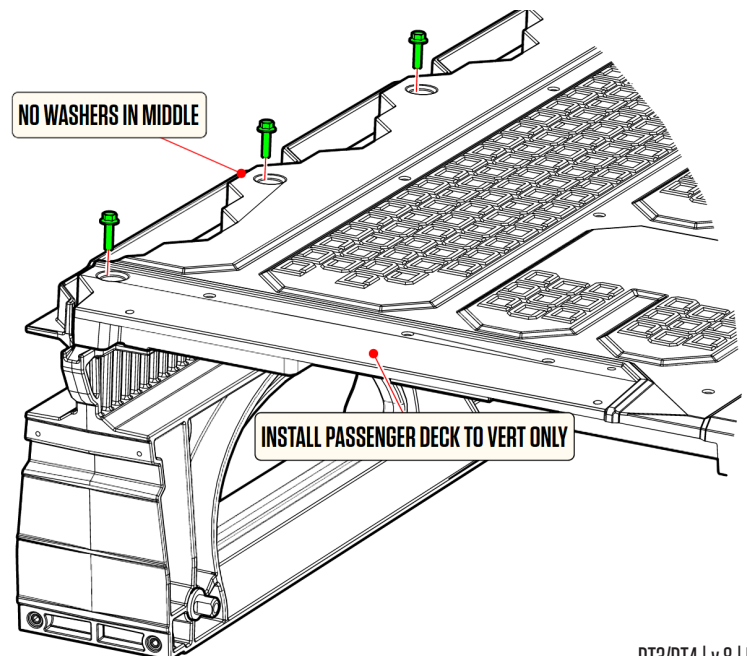
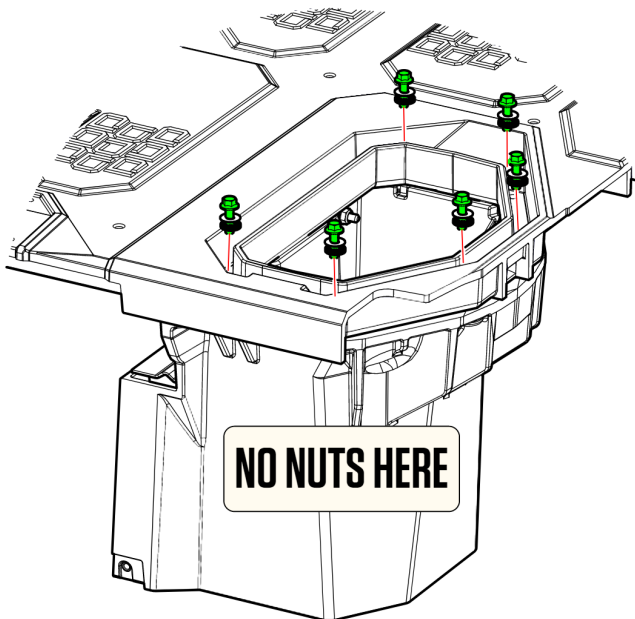
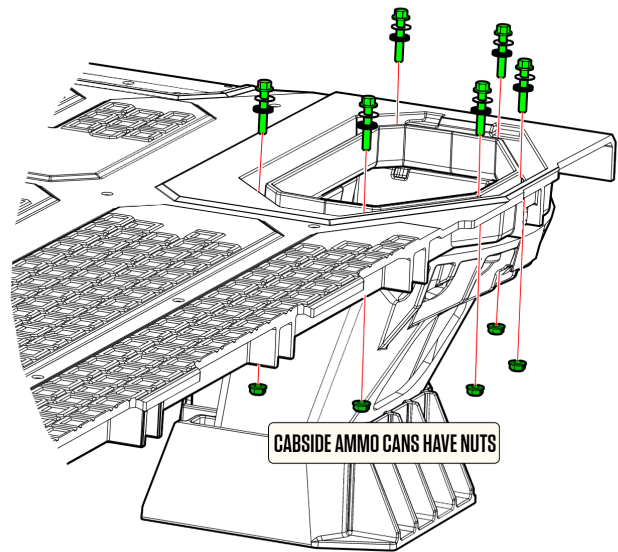

GET THE REST OF YOUR DECK ON

1. Seat the driver side deck on the ammo cans and center vert.
2. Attach the deck to both ammo cans, repeating steps 4 and 5 from the previous page.
3. Do not attach the driver side deck to the center vert.
4. Now you can tighten the eight (8) C-channel to ammo can bolts. Don't forget unless you like rattles.
5. Gently remove the driver side assembly from the vert and put aside. If you attached the driver side deck to the vert, see #3 above and carefully remove the bolts.

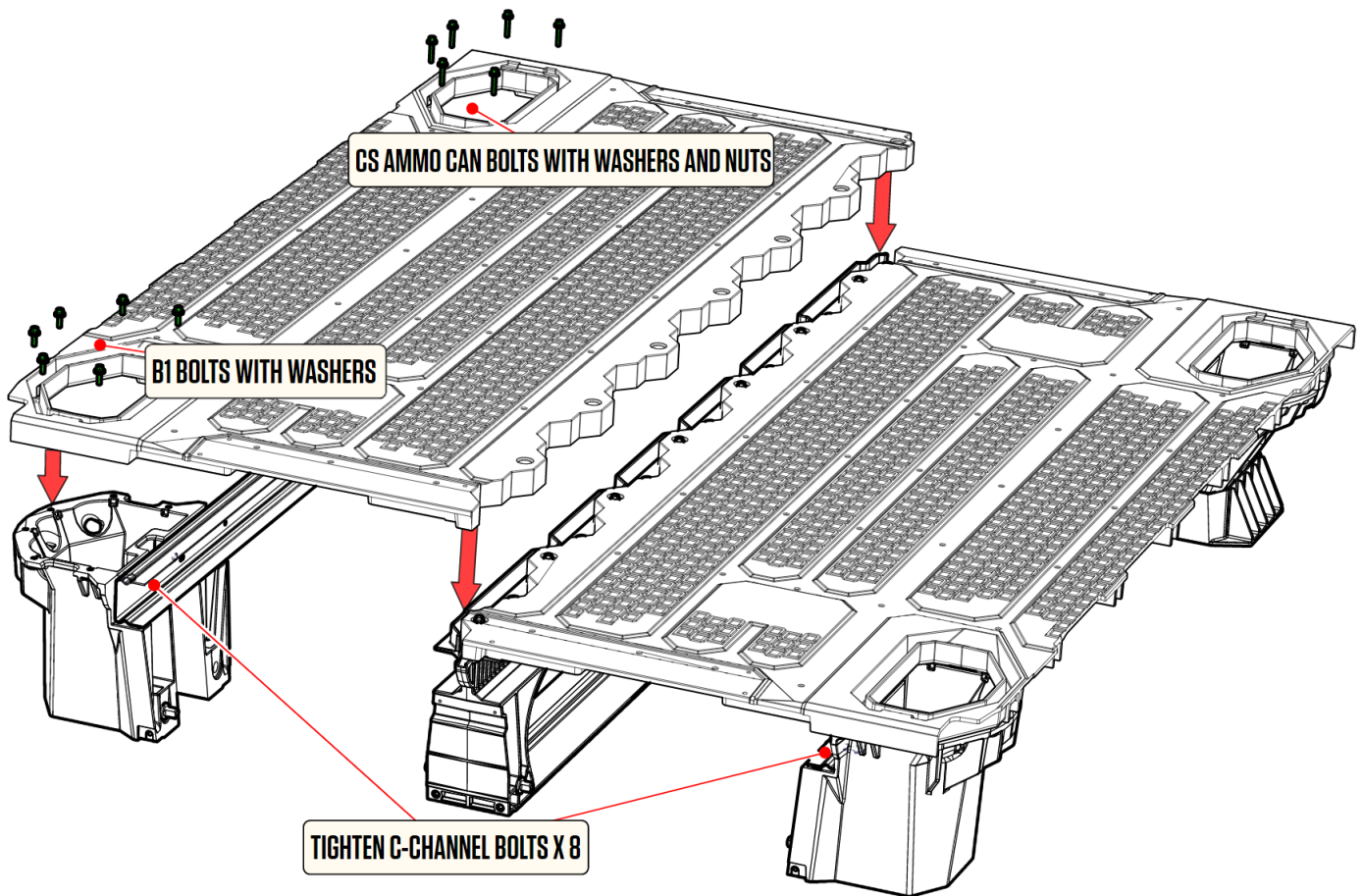

6. Find a friend to help you lift and place the passenger side assembly into the bed of your truck.
7. Nicely ask the same friend to lift and place the driver side assembly into the bed and seat onto the center vert.
8. Install the driver side panel to the center vert using B1 bolts with NO WASHERS . If you have a 5'6" bed, you'll have two extra B1 bolts. Lucky you. Everyone will have extra washers.

DRAWERS: BRACKETS + WHEELS

(EASIER THAN FALLING OFF A LOG)

- Each drawer has a left and a right bracket. Bolt the brackets into place via bottom two holes in bracket with 3/4" length bolts. Use the 2" length bolt for the upper cabside wall hole in bracket; **BAG DRAWER 1**.
- Install a tube brace in each drawer with two 3/4" length bolts; **BAG DRAWER 1, BAG DRAWER 3**.
- Attach wheels onto the drawer brackets with a 7/32" hex wrench; **BAG WHEELS**.

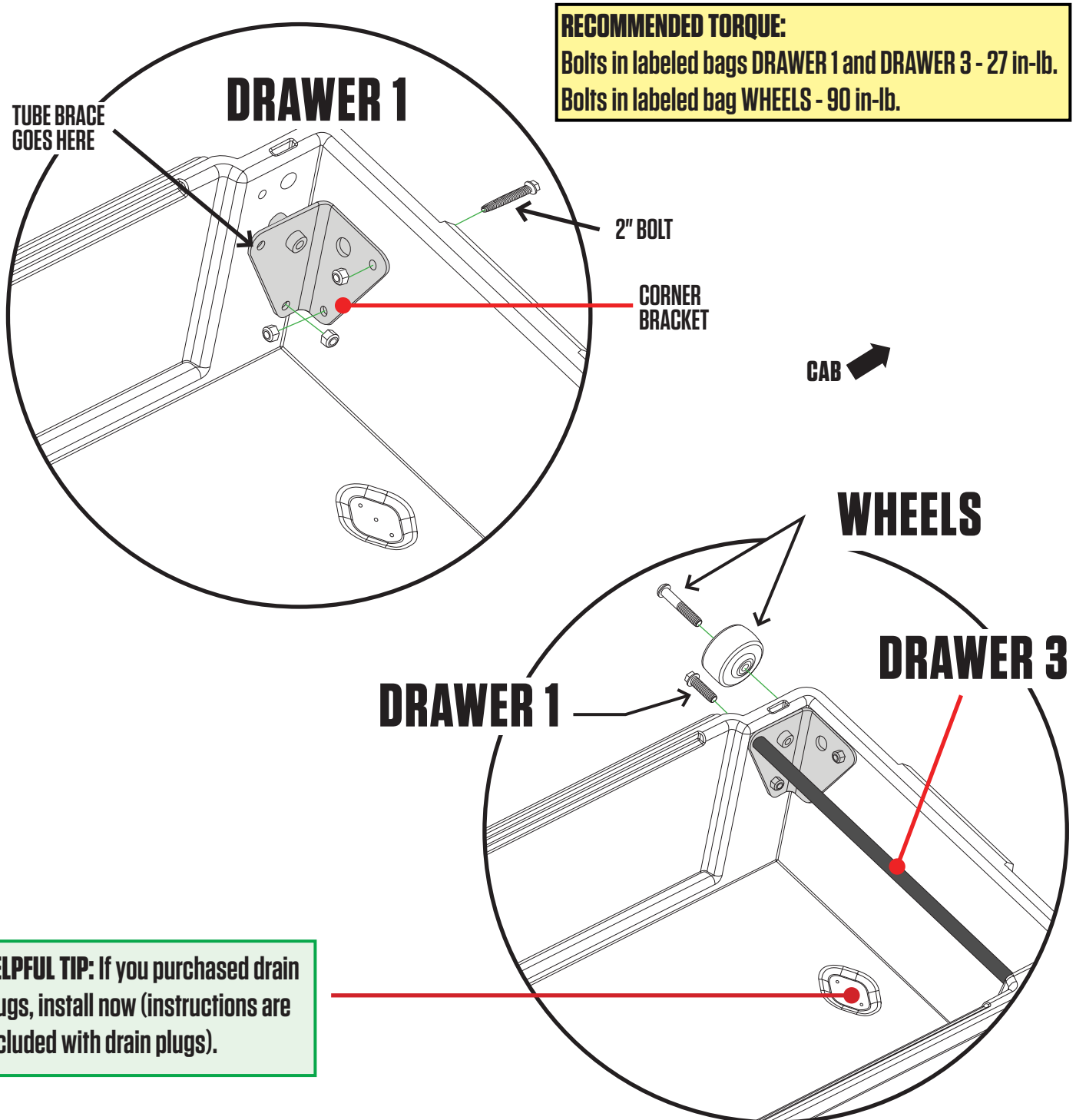

INSTALL: DRAWER HANDLE

- OK, Sparky, one drawer handle assembly needs to be installed by you. We did the other one.
- Save yourself the headache, watch this short installation video: [DECKED.com/videohandle](https://www.decked.com/videohandle).
- From the **underside** of drawer, place the springs into the cavities on either side of the handle slots, red spring=right spring; **BAG HANDLE**. **NOTE: Each spring arm should point inward, not outward.**
- Install a clevis pin through each outside drawer hole and through spring; **BAG HANDLE**.
- With DECKED logo facing outward, insert the handle ends behind the spring arms. Rotate the arms of the handle toward the clevis pins, pulling the spring arm downward. When the handle hole is lined up with the clevis pin, push the pin through the handle hole and through the inside drawer hole. Repeat on the other side of the handle.
- Install a hair pin through the clevis pin; **BAG HANDLE**.

HANDLE OVERVIEW

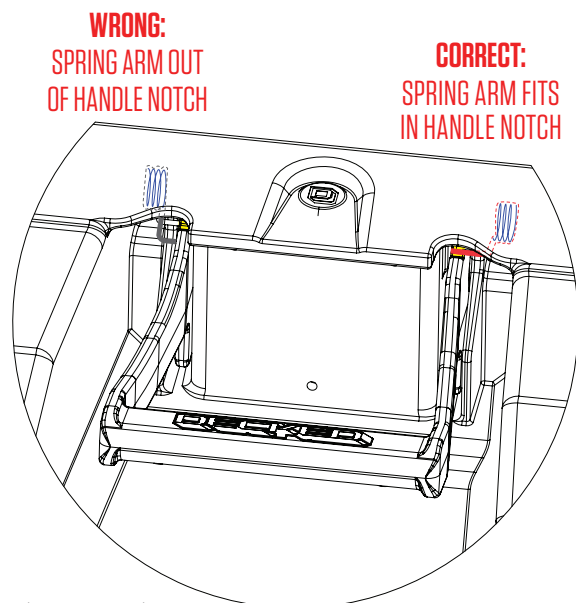
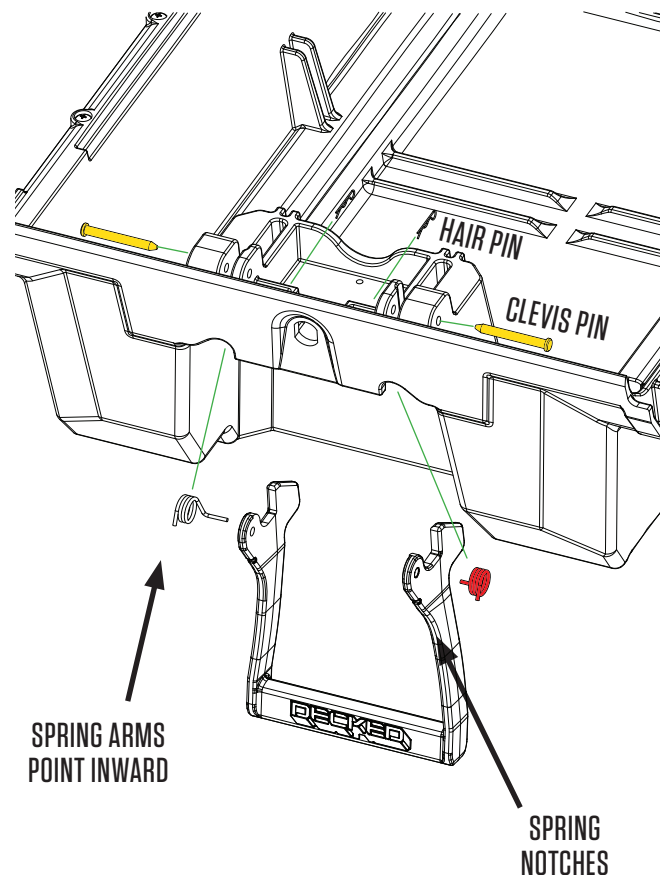
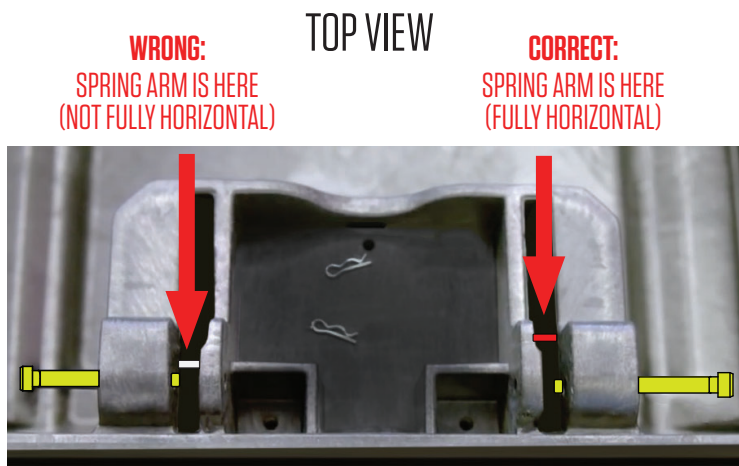

HELPFUL TIP: MAKE SURE SPRINGS HAVE THE LONG ARM HORIZONTAL AND SHORT LEG VERTICAL BEFORE INSERTING HANDLE



INSTALL: DRAWERS

- Save yourself the headache, watch this short installation video: [DECKED.com/videotailgatewheels](https://www.decked.com/video/tailgate-wheels).
- Install the drawer by sliding wheels into their two channels (C-channel and center vert), and slide drawer all the way forward until closed.
- Install the remaining tailgate side wheels onto their axles; **BAG WHEELS**.

NOTE: Placing a spacer under the drawer to raise it into position makes this easier (ammo can lids work well, or a small piece of 2x2 or 2x4).

- Install the weather strips on the tailgate side drawer edge: With the weatherstrip wiper facing cabside, line up one end with the side of the drawer and place on the top drawer edge, firmly pressing down on the weatherstrip as you move along the drawer edge.

NOTE: Facing the weather stripping the wrong way will funnel water into drawer: BAD!

- When the weatherstrip is fully seated along the top edge, trim off any material that extends beyond the drawer edge with wire cutters. Watch out for the stainless wire coil inside; it's sharp!

**RECOMMENDED TORQUE:
Bolts in labeled bag WHEELS - 90 in-lb.**

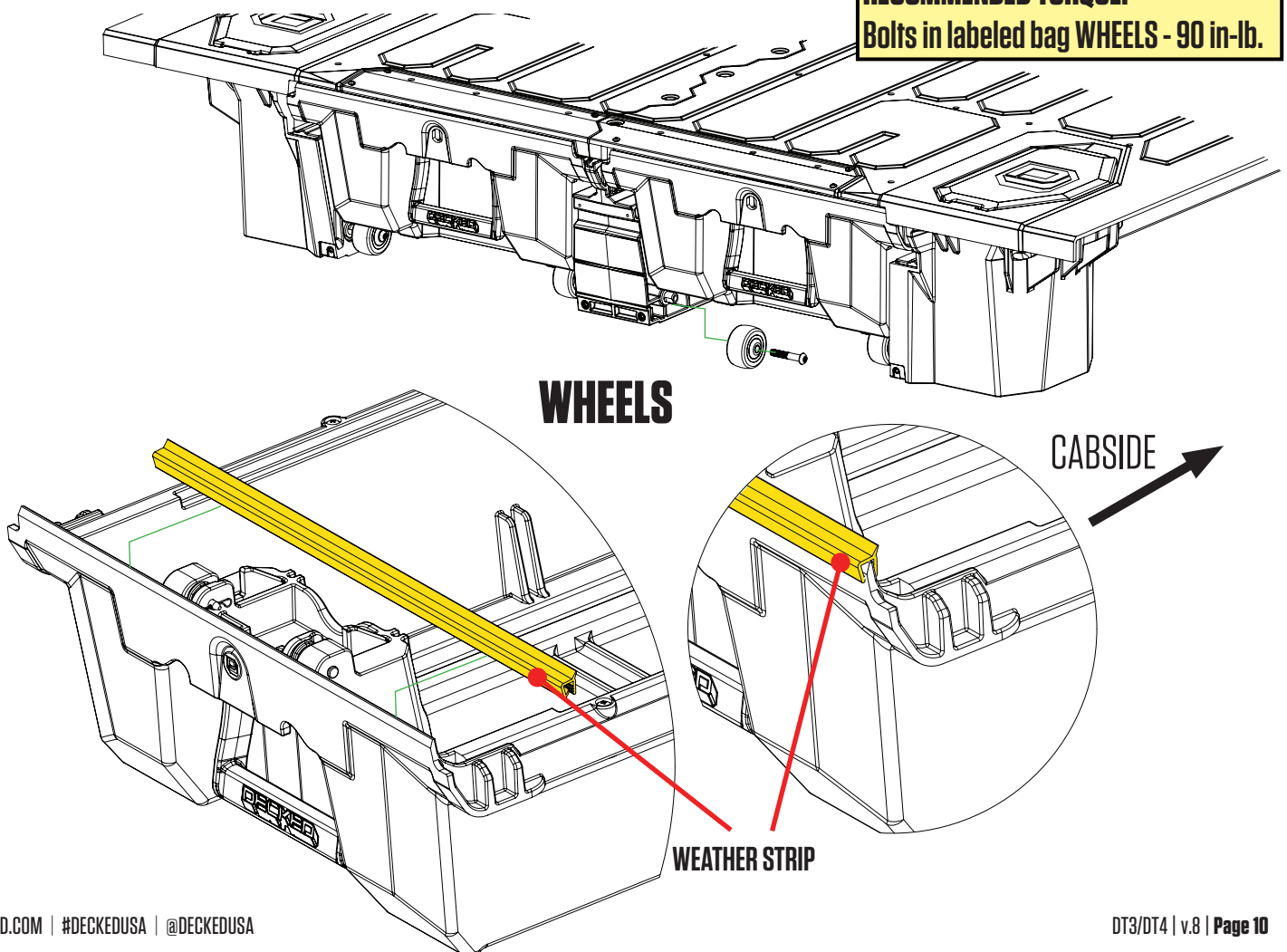

INSTALL: THE FUN STUFF

- Use the **WASHERS** bag and **PREP TBO** bag for the following steps.
- Slide torsion brace under center vert and tailgate ammo cans. Place bottle opener on the outside of the torsion brace.
- Loosely install (start with your fingers to avoid cross-threading):
 - Two 1/2" bolts through upper holes in the bottle opener into the center vert – no washers needed; leave loose.
 - Two 1" bolts with nylon washers through the end holes in torsion brace into tailgate ammo cans; leave loose.
 - Two 1" bolts with nylon washers through the bottom bottle opener holes and torsion brace into center vert; leave loose.
- Align bottle opener to edges of center vert and tighten four bottle opener bolts.
- Tighten end bolts into tailgate ammo cans.

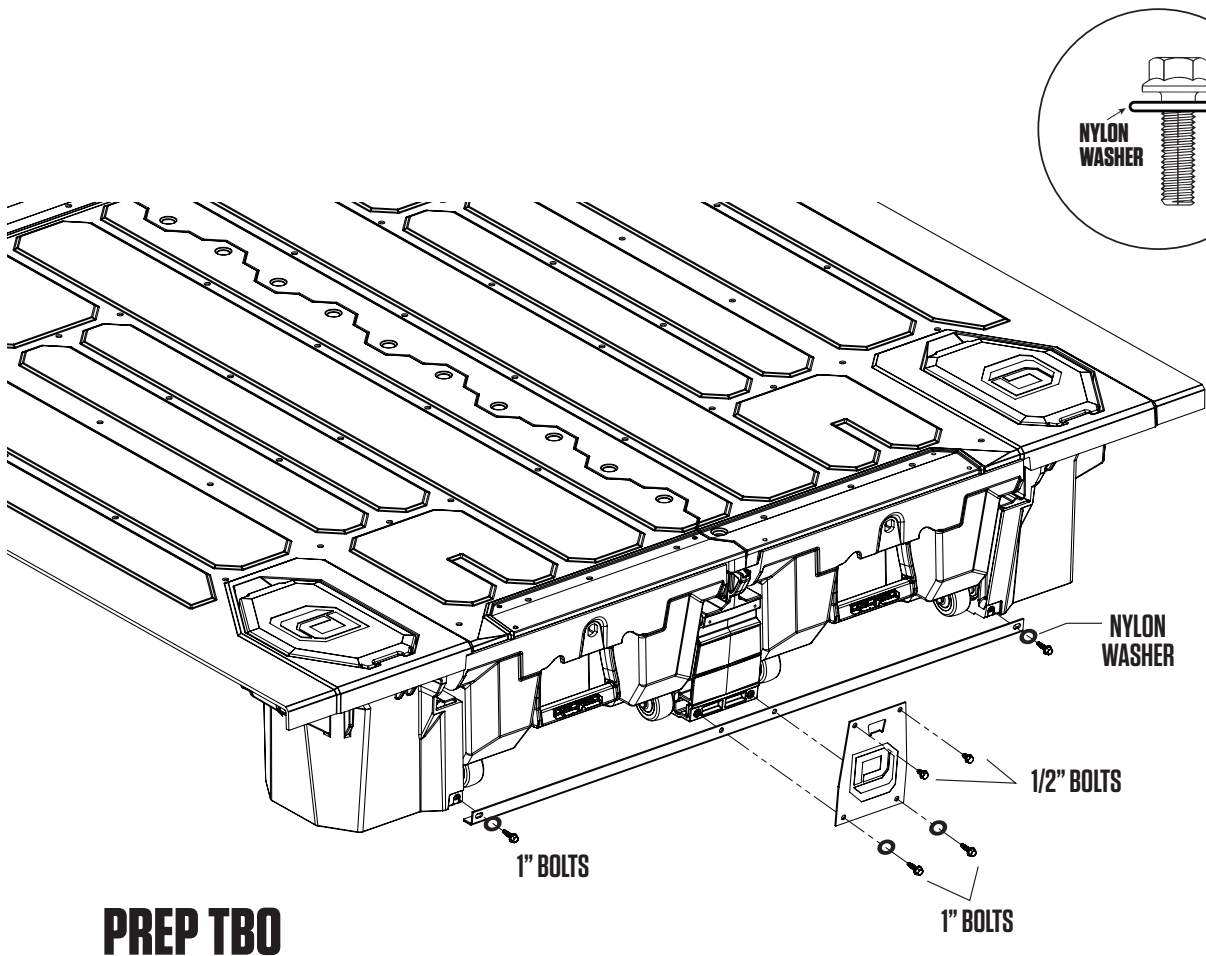

HELPFUL TIP: Bottle opener goes on the **outside** of the torsion brace.

RECOMMENDED TORQUE:
1" Bolts - 27 in-lb. | 1/2" Bolts - 18 in-lb.

INSTALL: J-HOOKS

- Insert the J-hook through the **tailgate** hole on the passenger side tailgate ammo can and loop J-hook through tie down or mounting bracket in bed. Screw on the winged-spherical nut-washer, round side down, on the J-hook and fasten until finger tight; **BAG J3**. Don't tighten yet. If you do, you won't be able to center the system properly in your bed.
- Insert the J-hook through **cabside** hole on the passenger side cabside ammo can and loop J-hook through tie down or mounting bracket in bed. Screw on the winged-spherical nut-washer, round side down, on the hook and fasten until finger tight; **BAG J3**. Don't tighten yet.
- Repeat with J-hooks and ammo cans on drivers side.

IMPORTANT: Leave all J-hook nuts loose.

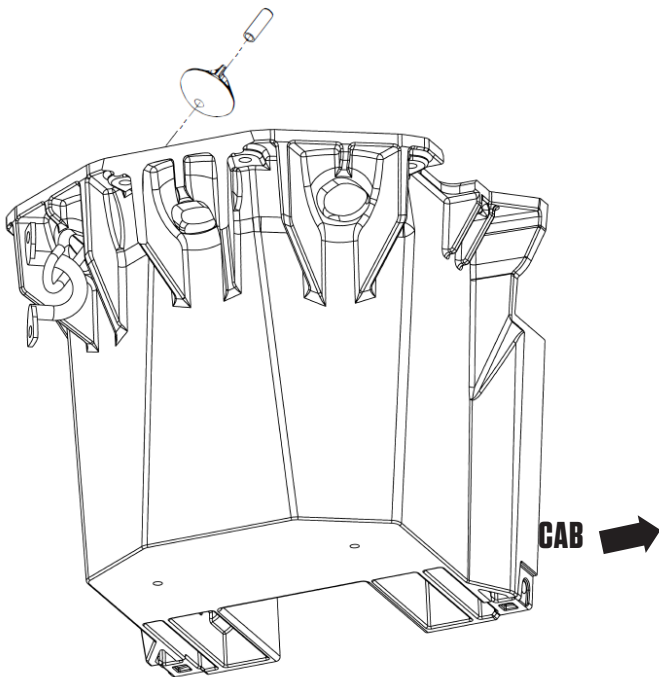

PASSENGER SIDE
TAILGATE AMMO CAN

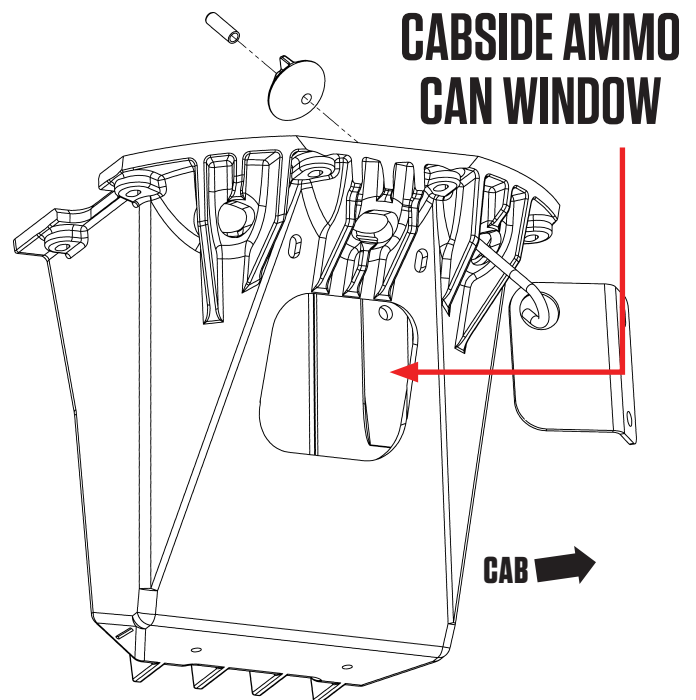

PASSENGER SIDE
CABSIDE AMMO CAN

TIGHTEN: J-HOOKS

- Finally, tighten the J-hooks, gradually and alternately. **DO NOT OVER TIGHTEN.**
IMPORTANT: Make sure to center the vert in the center of your bed. Don't worry about side gaps, center the vert on the center rib/trough of the bed.
- Install thread bolt protectors on J-hook ends; **BAG PREP TBO.**
- Install ruler by aligning the ruler holes with the inserts in the decks. Use your fingers to start the 1/4" screws to avoid cross-threading. Tighten just until snug with a 1/8" hex wrench.
- Insert lock core plugs, or install locks if purchased.
- Nice job. Your mother and I are very proud of you.

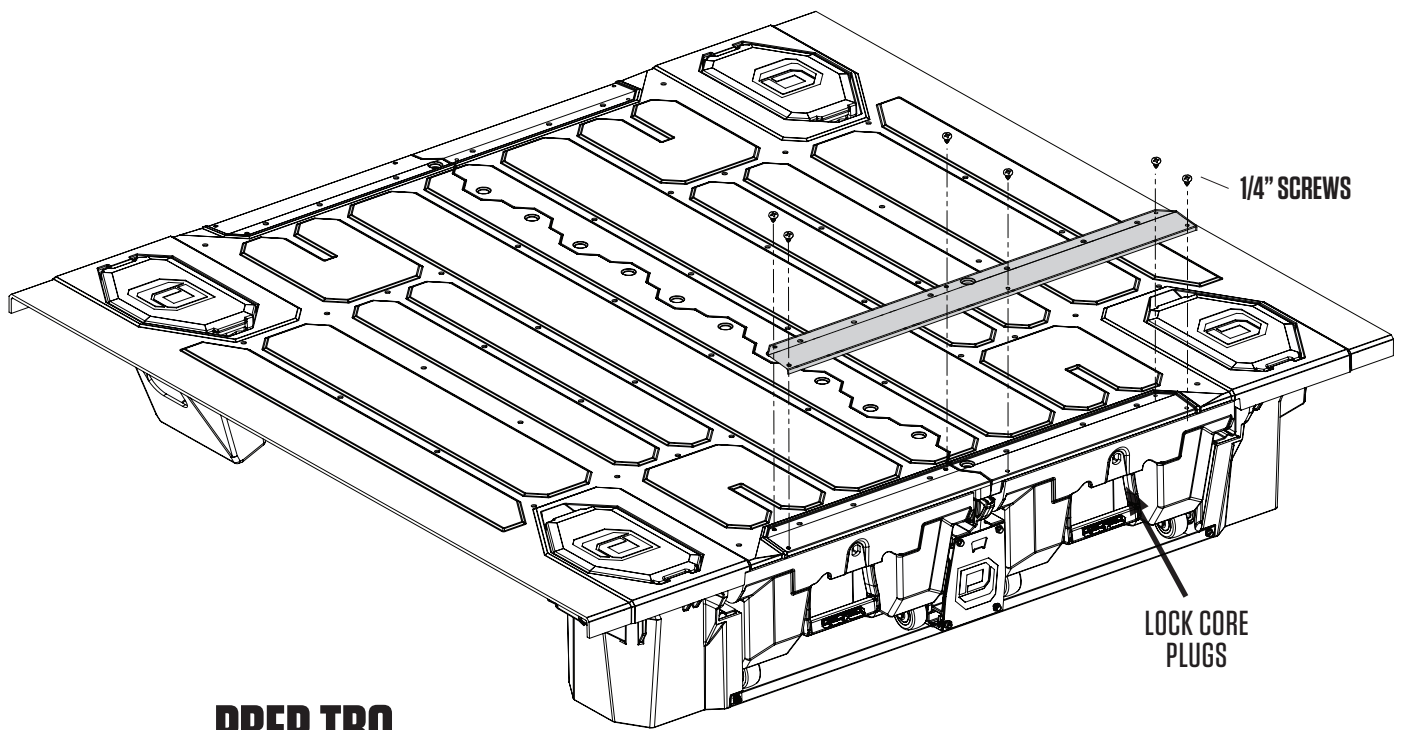

RECOMMENDED TORQUE: J-hooks - 9 in-lb.

IMPORTANT: Grab your favorite beverage, crack 'er open in the bottle opener and make a toast to your truck. You did it. Immediately post a photo of your significant other, child or canine (in no order of significance - please someone show us your pet alligator) appreciating your accomplishment. Add hashtag #DECKEDUSA | @DECKEDUSA.

DECKED Products – Limited Lifetime Warranty

(Valid on DECKED Products purchased on or after 8/1/2021)

DECKED LLC, (the “Manufacturer”) warrants the original purchaser only that DECKED Truck and Van Products (The “DECKED” Product) will be free from defects in material and workmanship from the date of purchase and continuing for the expected lifetime of the DECKED Product. The DECKED Product must be registered by the original purchaser with DECKED, LLC via its website at, www.decked.com/register, and a copy of the original sales receipt must be supplied to the Manufacturer at the time a warranty claim is made. This warranty terminates if the original purchaser transfers the DECKED Product to any other person or vehicle.

WHAT IS COVERED

All DECKED Products identified above on or after August 1, 2021

DECKED’s Limited Lifetime Warranty applies to US and Canadian customers only. International shipments are covered by DECKED’s 3 Year Limited Warranty.

WHAT WE WILL DO TO CORRECT PROBLEMS

Subject to the limitations and exclusions described in this limited warranty, the Manufacturer will remedy defects in workmanship or materials by providing one of the following remedies at its option and without charge to the original purchaser for parts: (a) repairing the defective portion of the DECKED Product or (b) replacing the entire DECKED Product. In addition, the Manufacturer may elect at its option not to repair or replace the DECKED Product, but rather issue to the original purchaser a refund equal to the purchase price paid for the DECKED Product or a credit to be used towards the purchase of a new DECKED Product.

WHAT IS NOT COVERED

This limited warranty expressly excludes:

- Damage or defects caused by normal wear and tear, cosmetic rust, scratches, accidents, unlawful vehicle operation, installation in a non-supported vehicle or installed in a vehicle which does not match the DECKED Product’s SKU-intended fitment or use, or modification of the product, or any types of repair of a DECKED Product other than those authorized or provided by the Manufacturer.
- Damage or defects resulting from conditions beyond the Manufacturer’s control and specifications including, but not limited to modification, misuse, overloading, or failure to assemble, install or use the DECKED Product in accordance with the Manufacturer’s written instructions or guidelines included with the DECKED Product or separately made available to the original purchaser.
- Damage to the contents of the DECKED Product or vehicle.
- TO THE EXTENT PERMITTED BY LAW, IN NO EVENT SHALL THE MANUFACTURER BE LIABLE FOR ANY INCIDENTAL, SPECIAL, INDIRECT, OR CONSEQUENTIAL DAMAGES, INCLUDING ECONOMIC LOSS, WHETHER RESULTING FROM NONPERFORMANCE, USE, MISUSE, OR INABILITY TO USE THE DECKED PRODUCT OR THE MANUFACTURER’S NEGLIGENCE.

NO OTHER EXPRESS WARRANTY APPLIES

This Limited Lifetime Warranty is the sole and exclusive warranty for DECKED Products. No employee, agent, dealer, or other person is authorized to alter this warranty or make any other warranty on behalf of DECKED LLC.

NOTIFICATION PROCEDURES

If the DECKED Product does not conform with the terms of this limited warranty, the original purchaser must promptly notify the Manufacturer in writing upon discovery of the nonconformity. In order to receive remedies under this limited warranty, a warranty claim must have been registered with DECKED LLC by the original purchaser, must describe the nature of the products nonconformity, include a copy of the original sales receipt, invoice, or other proof of purchase and be accompanied with photos or video. Repairs or modifications made to the DECKED Product by other than the Manufacturer or its authorized agent will nullify this limited warranty. Coverage under this limited warranty is conditioned at all times upon the owner’s compliance with these required registration, notification, and repair procedures.

Product registration may be performed at: <https://decked.com/register>

Warranty claims must include reciprocal contact information and may be made via certified mail or email to:

DECKED Warranty and Claims

Contact info:

DECKED LLC

PO Box 885

Ketchum, ID 83340

warranty@decked.com

208-806-0251

DECKED.COM | #DECKEDUSA | @DECKEDUSA

