

CARE AND USE OF THE ULTRA-JACK® SCAFFOLD SYSTEM

- 1) Prior to use, the user should inspect the installation to insure that the system is properly set up and ready to use.
- 2) Do not use equipment if wet or frozen.
- 3) Lubricate crank handle bushing with one or two drops of all-purpose lubricating oil as necessary. Keep rubber surfaces clean of all lubricant. Do not use spray-type lubricants.
- 4) Rubber surface should be cleaned as necessary using a soft cloth and Isopropyl Alcohol (rubbing alcohol).
- 5) An access ladder shall provide safe access to and from the work platform.
- 6) Ultra-Jack Scaffolding must not be used over 48 feet off the ground.
- 7) There should never be more than two people on an Ultra-Jack System between any two poles.
- 8) Only one walk plank shall be supported between any two poles.
- 9) Additional safety accessories such as guardrails, mid-rails, toe-boards, fall arrest harness systems must be used as required by Federal OSHA Regulations.

This product must be used in strict compliance with local, national or OSHA legislation which applies.

WARNING

FAILURE TO UNDERSTAND AND FOLLOW ALL SAFETY RULES AND ASSEMBLY INSTRUCTIONS COULD RESULT IN SERIOUS INJURY OR DEATH.

To prevent an unstable scaffold that could lead to serious personal injury:

- Use only Ultra-Jack products as part of this system. Do not use with other manufacturers' pump jacks, poles or accessories.
- Do not use with wood poles.
- Do not use above 48 feet.
- Poles must be secured with rigid triangular steel bracing at top, bottom and at points in-between in accordance with instructions.
- Do not use without guardrails, mid-rails toe boards, and or a fall-arrest system. OSHA requires the user to have knowledge of all regulations that apply to the use and care of this product and that the employer must provide training.

- This product must be used in strict compliance with with local, national or OSHA legislation which applies.
- Inspect all Ultra-Jack equipment before and after each use. Be sure that there is no damage or deformation to any of the equipment.
- Inspect the rubber surface of the pole before and after each use for worn or damaged surface, replace if necessary with Ultra-Jack replacement components.
- When joining two poles always inspect splices to insure that there is no gap between rubber surfaces.

CAPACITY:

Pump jack scaffolding should not carry more than two people or 500 lb between any two poles. This capacity considers a 4:1 safety factor as required by OSHA Standards when installed and used in accordance with the instructions.

WHEN USED IN ACCORDANCE WITH INSTRUCTIONS THIS PRODUCT MEETS U.S. DEPARTMENT OF LABOR O.S.H.A. REGULATIONS

Customer Service: 1 800 363-7587

Our customer service staff is available to help you. For help with product assembly, to report damaged or missing parts, or for any other information about this product, please call our toll-free number.

KEEP THIS MANUAL FOR FUTURE REFERENCE

Keep this manual and the original sales invoice in a safe, dry place for future reference.

One Year Limited Warranty

Metaltech-Omega Inc. guarantees this product against any material defect. Please return this product, freight prepaid, to Metaltech-Omega Inc. At its own discretion, Metaltech-Omega Inc. will replace or repair this product and return it within a reasonable time. This warranty does not cover any damage(s) caused by any incorrect or inappropriate use, care or maintenance. Proof of purchase must accompany the return.



WWW.METALTECH.CO
1 800 363-7587

LAVAL, QUEBEC, CANADA H7L 3N6

Metaltech is a registered trademark of Metaltech-Omega inc.

IN-PJAL-NA-EN03



ULTRA-JACK® SYSTEM

OPERATIONAL SAFETY AND ASSEMBLY INSTRUCTIONS

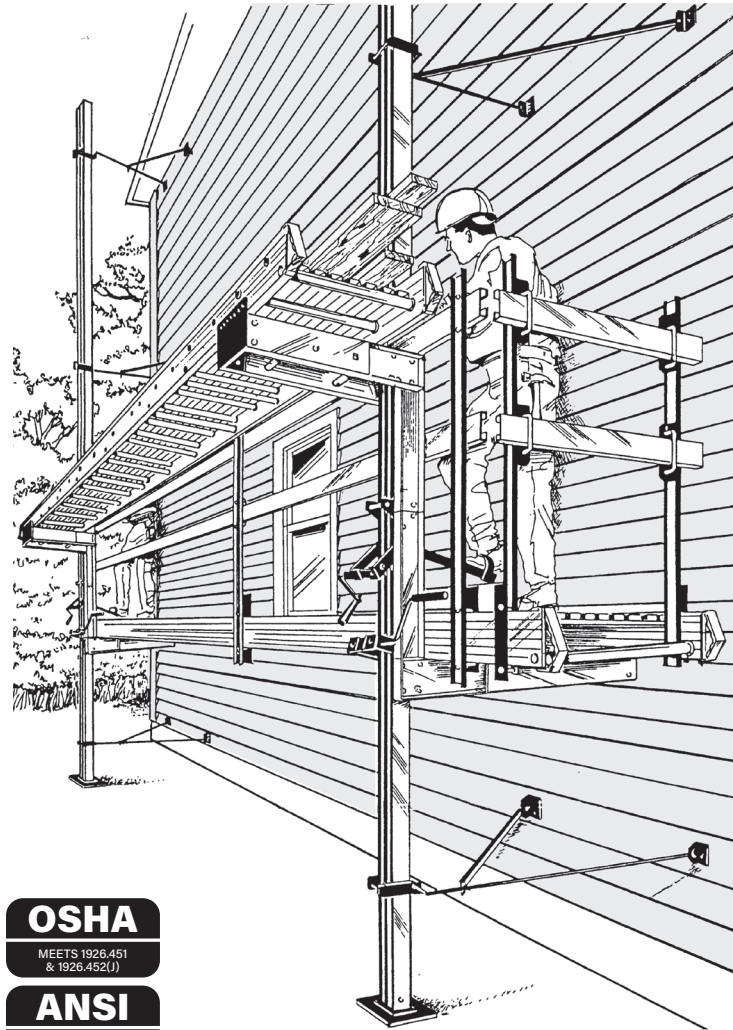

ENGLISH

Pictures may differ from actual product



READ THESE INSTRUCTIONS CAREFULLY BEFORE USING THIS PRODUCT. KEEP THIS MANUAL HANDY FOR FUTURE REFERENCE.



METAL CONDUCTS ELECTRICITY:

Do not use this equipment where contact may be made with power lines or other live electrical circuits.



INSTRUCTIONS FOR THE INSTALLATION ULTRA-JACK® SYSTEM

GENERAL WORKSITE CONDITIONS

- A) Insure worksite is free of construction debris.
- B) Survey the work site for the location of power lines; contact electric company for appropriate precautions. Never install this scaffold system in close proximity to power lines, as this aluminum scaffold system will conduct electricity.
- C) Inspect all power tools and extension cords. Damaged tools and cords can cause serious personal injuries.

EVALUATE AND PLAN WORK SITE LOCATION

- A) Intended work area should not exceed 48 feet in height.
- B) Plan location of poles. Distance between poles should correspond to the type of walk planks being used. See section on choosing a walk plank.
- C) Insure that poles rest securely on a firm foundation. Always use the most appropriate pole accessory based on ground conditions.

CHOOSING SYSTEM COMPONENTS

- A) Use only Ultra-Jack products as part of this system. Do not use with other manufacturers' pump jacks, poles or accessories.
- B) Do not use with wood poles.
- C) Always use Ultra-Jack Pole Braces (rigid triangular bracing) at top, bottom and at points in-between as required, in accordance with these instructions

SYSTEM COMPONENTS

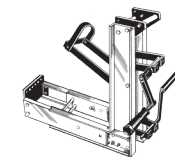

ULTRA-JACK
MODEL: PJ-PJAL

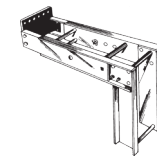

ULTRA-JACK WORKBENCH
MODEL: PJ-WBAL-

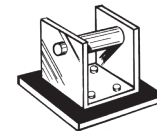

ULTRA-JACK ANTI-SLIP POLE BASE
MODEL: PJ-PBAL

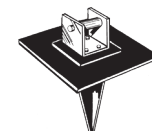

ULTRA-JACK POLE ANCHOR
MODEL: PJ-PAAL



ULTRA-JACK BRACE
MODEL: PJ-BAL



ULTRA-JACK 6 FT POLE CONNECTOR
MODEL: PJ-C06



ULTRA-JACK ALUMINUM/ RUBBER POLE
6 FT MODEL: PJ-P06
12 FT MODEL: PJ-P12
24 FT MODEL: PJ-P24

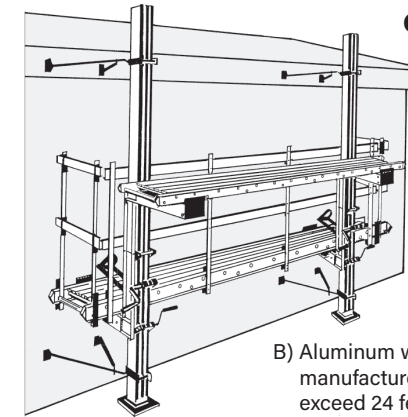

CHOOSING A WALK PLANK

A) Wood walk planks shall be made of Scaffold Grade or equivalent lumber. When fabricated from 2-inch full thickness, undressed lumber the maximum span between supports shall not exceed 9 feet. When fabricated from 2-inch nominal thickness lumber, the maximum span between supports shall not exceed 7 feet.

B) Aluminum walk planks must have been manufactured for that purpose and shall not exceed 24 feet in length.

- C) All walk planks shall be overlapped a minimum of 12 inches and secured from movement except when using aluminum walk planks designed to be fastened together. For this style walk plank the joint must be secured in place directly over the Ultra-Jack support arm.
- D) All scaffold planks must extend no less than 6 inches and no more than 12 inches over the support arm.
- E) OSHA regulations require that the platform be fully decked and that the minimum width be 12 inches.

INSTALLATION OF THE ULTRA-JACK®

A) The Ultra-Jack should be installed onto the Ultra-Jack Aluminum/Rubber Pole prior to installation of the pole to the work wall. First place the Aluminum/Rubber Pole on the ground with the rubber surface facing upward.

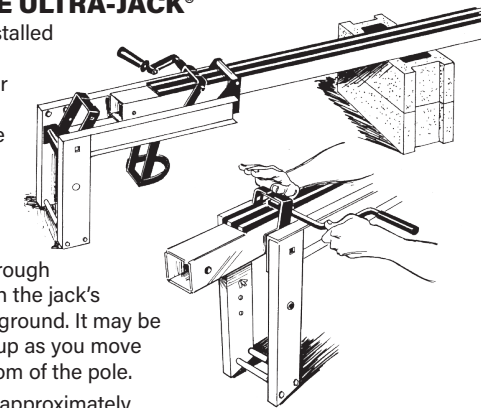

B) Slide the bottom of the pole (exposed aluminum end) through the top of the Ultra-Jack with the jack's platform retainer facing the ground. It may be necessary to pump the stirrup as you move the Ultra-Jack from the bottom of the pole.

C) Stop when the Ultra-Jack is approximately 1 foot up from the bottom of the pole.

INSTALLATION OF BRAKE ASSEMBLY

A) Slide brake pedal rod through square holes. The rod should go through holes on both sides of the brake mechanism.

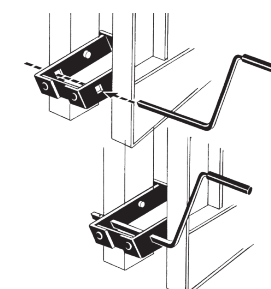

B) Slide the cotter pin through the small hole at the end of the brake pedal rod and bend as indicated to prevent the rod from sliding out of position.

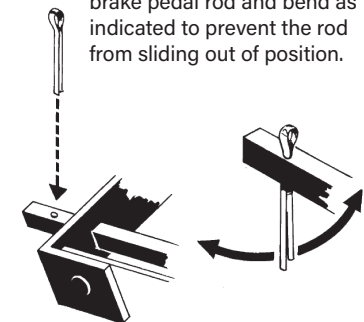

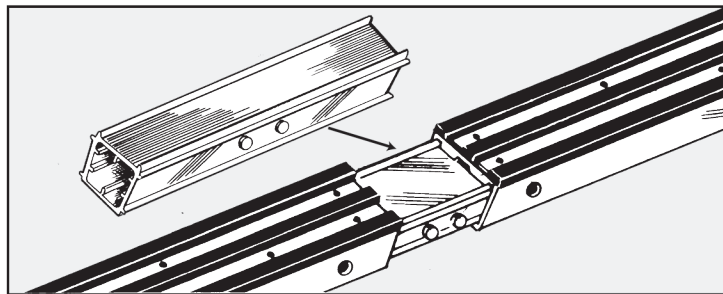

ASSEMBLY OF THE ULTRA-JACK® ALUMINUM/RUBBER POLE

- To join two Ultra-Jack Aluminum/Rubber Poles together orientate both poles so that the ends that provide a rubber surface that is even with the cut end of the pole are being connected. Never join more than two poles of any length together.
- Assemble two Ultra-Jack Aluminum/Rubber Poles by inserting the Ultra-Jack Pole Connector into one of the two Ultra-Jack Aluminum/Rubber Poles so that the button locks engage into the holes located approximately two inches in from the end of each pole. It will be necessary to depress the button locks prior to inserting the Pole Connector so that they can glide just inside the pole until reaching the corresponding holes in the pole. Check to insure that the buttons snap securely into the holes locking the connector into position.
- Slide the second pole over the remaining exposed section of the Pole Connector in the same way, insuring that the buttons snap into the holes on the pole.
- Inspect to insure that the rubber surfaces abut each other without a gap.

INSTALLING THE ULTRA-JACK® ALUMINUM/RUBBER POLES ALONG THE WORKING WALL OF THE BUILDING

- Plan the location of each pole based on the type of walk plank being used. Never install with spans between poles greater than those required by the type of walk plank being used. Doing so could lead to an unstable scaffold system and serious personal injury.
- Do not install pole on unstable ground, on top of other scaffolds or on roof surfaces. Inspect ground to insure that the pole will rest on a firm level surface.
- Use a Pole Anchor or Rubberized Base Plate at the bottom of each pole. Pole Anchors should be used when ground conditions require the need to spread the pole's load over a wider area, such as soft surface materials. When paved and/or solid ground surfaces are present use a Rubberized Pole Base. Insert Pole Base or Anchor into the bottom of the pole so that the button locks are fully engaged.

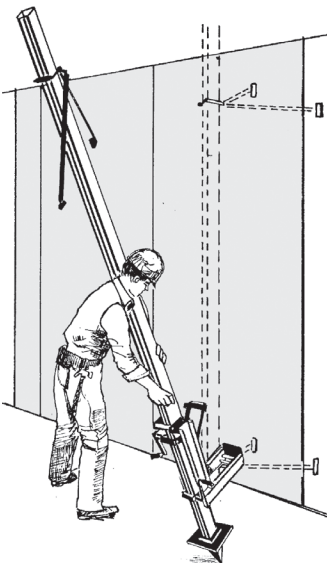

- Using a Ultra-Jack Brace, secure all poles to the work wall at the bottom and the top of each pole, and at other points as necessary. For poles longer than 24 feet, install intermediate bracing every 16 feet. Poles must be plumb. The rubber surface of each pole should face out from the work wall. The round bar of the pole brace should be fastened to the work wall at right angle to the pole. The angle of the bar should then be fastened to the right or left as desired. Fasten using two 2 inch or longer #12 wood screws per fastening plate. Always fasten to structural members; stud, rafter or joist. The spread between the brace arms is 32 inches thus enabling installation on studs 16 inches on center.

INSTALLING WALK PLANKS

- Extend the platform arm of each Ultra-Jack to the actual width of the walk platform and secure in place by tightening the fasteners along the side of the adjustable arm.
- Place appropriate decking between two Ultra-Jack System. See "Choosing a Walk Plank".
- Walk planks should overhang the Ultra-Jack platform arm not less than 6" and not more than 12" on either end. When using more than two walk planks to complete a system installation, overlap and secure plank as required by OSHA.
- Secure walk planks to each Ultra-Jack with the chains attached to each platform arm, passing the chain over and under the rungs and securing to the Ultra-Jack with the hardware provided. A padlock may be used for added security.
- Always erect the scaffold system so that the working or standing platform is level.

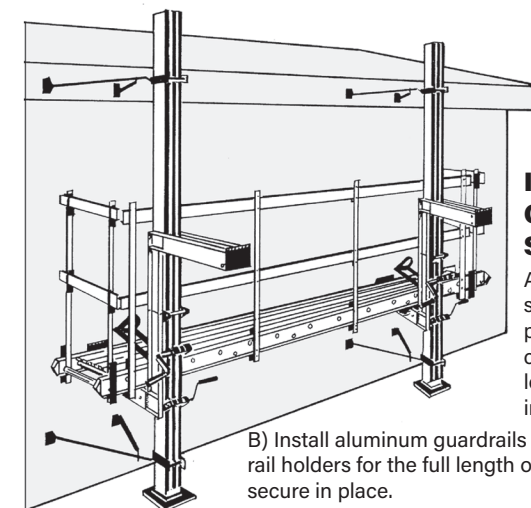
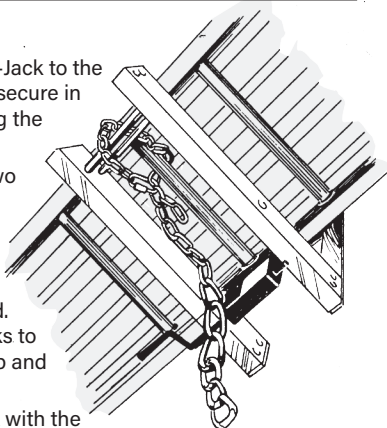

INSTALLING A GUARDRAIL SYSTEM

- Install a guardrail support arm to the walk plank at each of the outside corners and along the length of the walk plank in increments of 8 feet or less.
- Install aluminum guardrails at both the top and mid-rail holders for the full length of the walk platform and secure in place.
- Install toe boards along the length of the walk plank and secure in place.
- Install End rail System (top, mid-rail & toe boards) at each end of the work platform.
- See Walk Plank Manufacturer for additional instructions regarding guardrail systems.

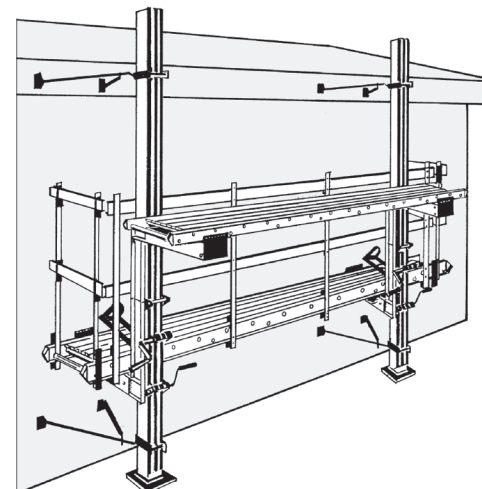

INSTALLING WORKBENCH

- Begin installation of the workbench brackets by removing the top bolt and roller assembly and bottom bolt. (see fig #1)
- Place each bracket (with the platform arm up and pointing away from the work wall) over the pole just above the Ultra-Jack. (see fig.#2) Re-install the upper roller bolt and lower bolt assemblies so that each workbench bracket rides on top of the Ultra-Jack and that the lower bolt goes through the top connector plate of the Ultra-Jack. Re-install nut and cotter pin on each bolt. (see fig.#3)
- Install the workbench platform by first adjusting the platform arm of the workbench to the width of the platform and secure in place by inserting and tightening the fasteners along the side of the adjustable arm.
- Place the workbench platform on the platform arm.
- Always erect the scaffold system so that the working or standing platform is level. Overlap each workbench platform arm and secure in place. in the same manner as with the walk planks.
- The installation of a workbench does not substitute for the upper guardrail as required by OSHA regulations.
- Do not stand on the workbench or use it for any purpose other than providing a work surface for tools and materials.

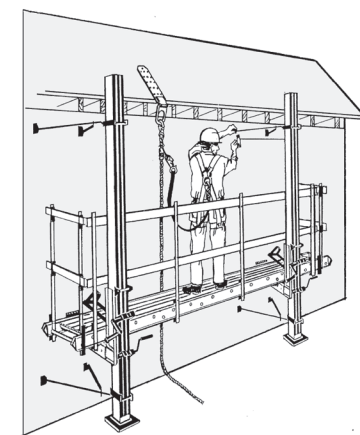
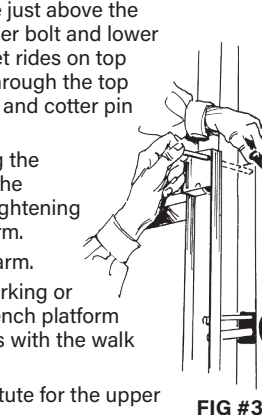
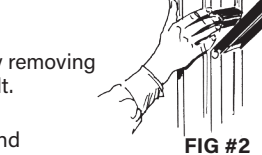
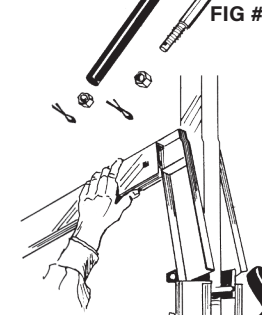

FALL PROTECTION

When working at heights above 4 feet it is necessary to comply with all local, national or OSHA regulations regarding the use of fall protection equipment. Always use guardrails, mid-rails, toe-boards and/or a personal fall protection harness system when using the Ultra-Jack System.

INSTRUCTIONS FOR USING THE ULTRA-JACK® SYSTEM

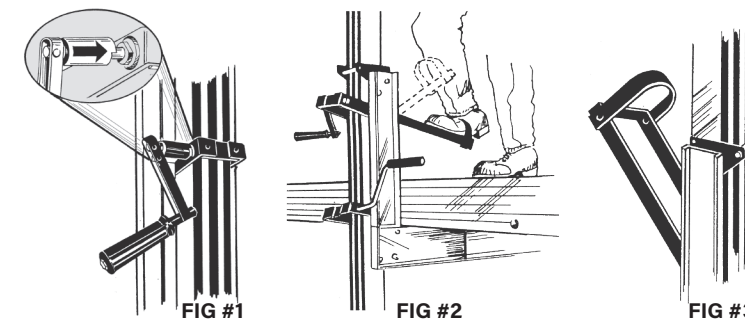

TO RAISE THE ULTRA-JACK® PLATFORM

- Stand on the walk plank with the jack and pole in front of you. Lock the crank handle by turning the handle until the spring lock engages. (see fig. #1)
- Place your foot in the stirrup and pump slowly until the platform is raised approximately 1 foot.(see fig. #2)
- Repeat this procedure with other Ultra-Jacks. Always keep the work surface level.
- Lock the Jack by placing the stirrup in the "UP" position. (see fig #3)

TO LOWER THE ULTRA-JACK® PLATFORM:

- With your back to the work wall, face the pole and raise the stirrup to the "UP" position (see fig.#3)
- Insure that the crank handle is in the locked position. (see fig. #1)
- Holding onto the pole, place one foot on the square pedal of the lower lock, press down and hold open. (see fig. #4)
- Take hold of the crank handle pulling the arm out to the right (see fig. #4) and begin turning the until the work platform reaches the desired height. Always keep work surface level.handle until the platform begins to lower. Continue lowering the platform for approximately one foot.
- Lock the Ultra-Jack by turning the handle untilthe lock ring is seated and the handle is no longer under spring tension.(see fig. #4) Release the square pedal to re-engage the lower safety lock.
- Repeat this procedure with the other Ultra-Jacks

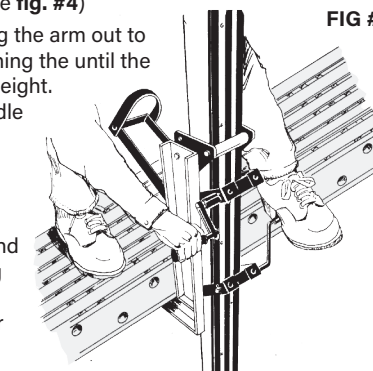

TO PASS AN ULTRA-JACK® BRACE

- When passing an Ultra-Jack Brace that is already installed, an extra brace should be installed approximately 4 feet above the one to be passed until the brace is reinstalled.
- After installing the temporary brace, loosen the wing nut and allow the brace to be passed to swing clear of the pole. Do not remove from the wall. After brace has been passed, reconnect it to the pole and remove the extra brace.

