

WARNING LINE POSITIONING

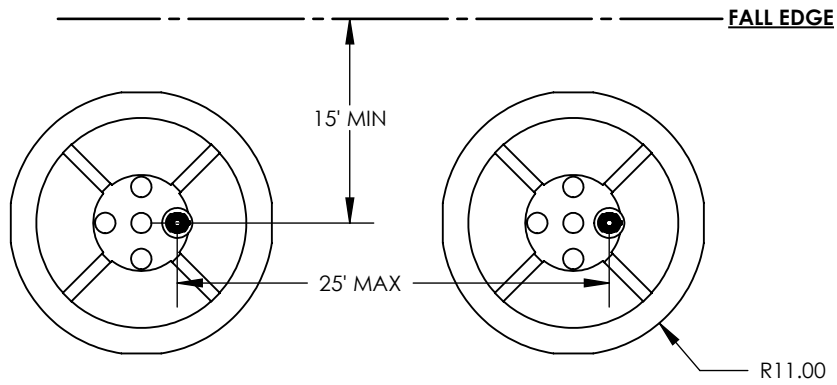

WARNING LINE COMPONENTS

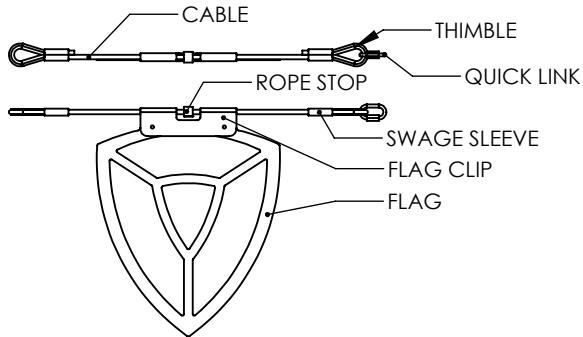

TYPICAL WARNING LINE CORNER

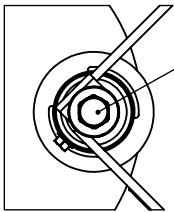
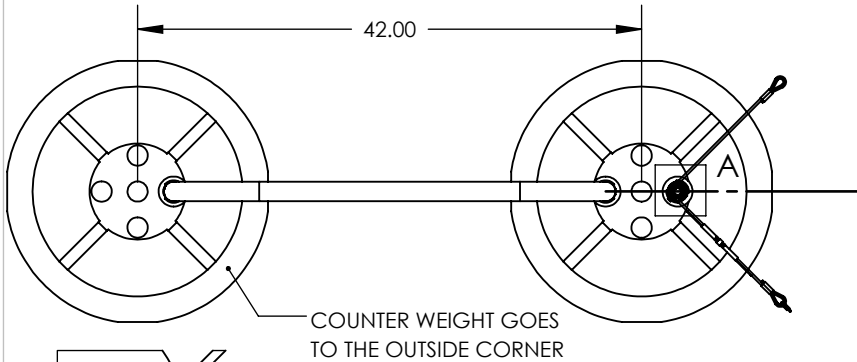

DETAIL A
SCALE 1 : 4

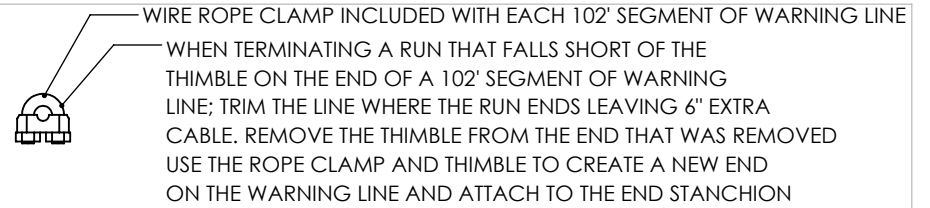

START/END STANCHION CONNECTION

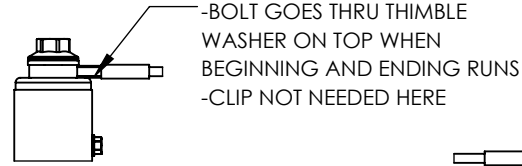

DETAIL C
SCALE 1 : 4

JOINING SEGMENTS

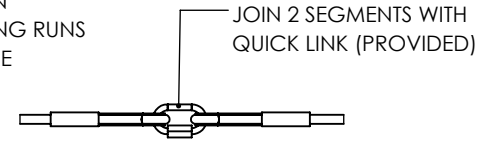

DETAIL B
SCALE 1 : 4

TYPICAL WARNING LINE RUN START/END

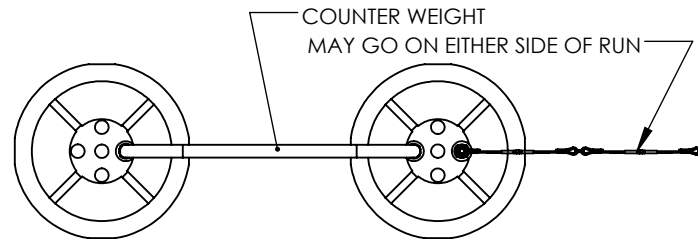
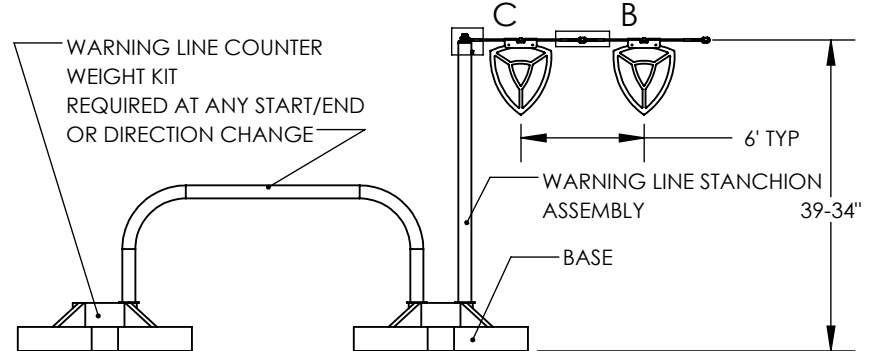

Safety Rail Company LLC.
4244 Shoreline Dr.
P.O. Box 427
Spring Park, MN 55384

Toll Free: 888-434-2720
Tel: 952-471-0950
Fax: 888-471-4931
www.safetyrailcompany.com
info@safetyrailcompany.com

TITLE: WARNING LINE INSTALL DIAGRAM-SRC 360

SIZE	DWG. NO.	REV
A		

SCALE: 1:16 WEIGHT: SHEET 1 OF 1