

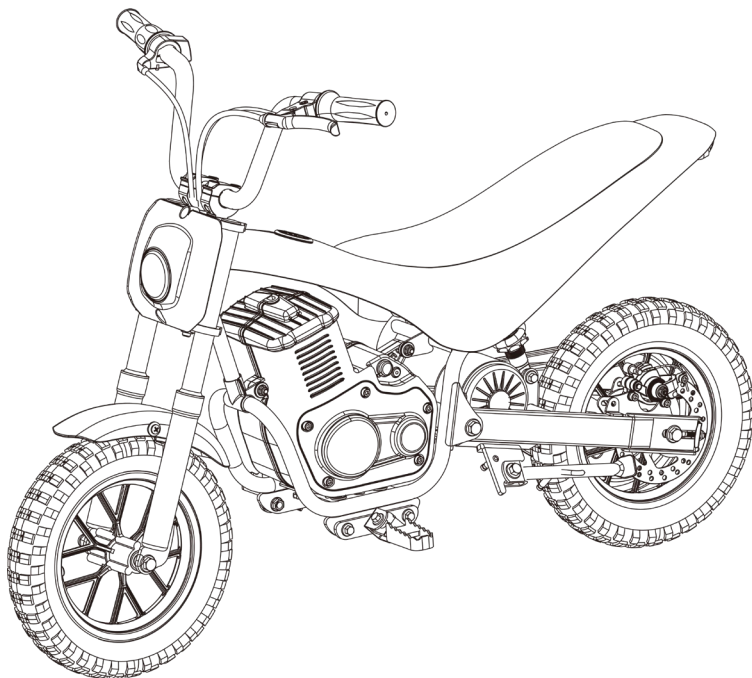

**BURROMINI**

**BURROMAX™**



**ELECTRIC MINI BIKE SERIES**

**Owner's Manual**

**Read and understand this entire manual  
before riding!**

# contents

|   |       |
|---|-------|
| Safety Warnings.....                    | 1-2   |
| Before You Begin.....                   | 3     |
| Assembly and Set-Up.....                | 4-5   |
| Before Riding.....                      | 6-8   |
| Repair and Maintenance.....             | 9-16  |
| Troubleshooting Guide.....              | 17-19 |
| TT250 SideView.....                     | 20    |
| TT250R – TT350R Side View.....          | 21    |
| TT250 Electrical Diagram.....           | 22    |
| TT250R – TT350R Electrical Diagram..... | 23    |
| Safety Reminders.....                   | 24    |
| Warranty Information.....               | 25    |

**NOTE: Manual illustrations are for demonstration purposes only.**

**Illustrations may not reflect exact appearance of actual product.**

**Specifications subject to change without notice.**

# Safety Warnings

**!WARNING:** Riding an electric mini bike can be a hazardous activity. Certain conditions may cause the equipment to fail without fault of the manufacturer. Like other electric products, these vehicles can and are intended to move, and it is therefore possible to lose control, fall off and/or get into dangerous situations that no amount of care, instruction or expertise can eliminate. If such things occur you can be seriously injured or die, even when using safety equipment and other precautions. **RIDE AT YOUR OWN RISK AND USE COMMON SENSE.**

This manual contains many warnings and cautions concerning the consequences of failing to maintain, inspect or properly use your electric mini bike. Because any incident can result in serious injury or even death, we do not repeat the warning of possible serious injury or death each time such a possibility is mentioned.

## **APPROPRIATE RIDER USE AND PARENTAL SUPERVISION**

This manual contains important safety information. It is your responsibility to review this information and make sure that all riders understand all warnings, cautions, instructions and safety topics and assure that young riders can safely and responsibly use this product.

**Burromax** recommend that you periodically review and reinforce the information in this manual with younger riders, and that you inspect and maintain your child's product to insure their safety. The recommended rider age 14 Years or older is only an estimate, and can be affected by the rider's size, weight or skills. Any rider unable to fit comfortably on the Mini Bike should not attempt to ride it.

**A parent's decision to allow his or her child to ride this product should be based on the child's maturity, skill and ability to follow rules.**

**DO not exceed the maximum recommended rider weight**

**!WARNING:** Rider weight does not necessarily mean a person's size is appropriate to fit or maintain control of the vehicles.

Keep this product away from small children and remember that this product is intended for use only by persons who are completely comfortable and confident when operating the products.

Do not touch the brakes or electric motor on your electric mini bike when in use as they can become very hot.

Refer to the section on safety for additional warnings.

## **ACCEPTABLE RIDING PRACTICES AND CONDITIONS**

**Always check and obey any local laws or regulations which may affect the locations where the vehicles may be used.**

Ride defensively. Watch out for potential objects that could catch your wheel or force you to swerve suddenly or lose control. Be careful to avoid pedestrians, skaters, skateboards, scooters, bikes, children or animals who may enter your path, and respect the rights and property of others.

The Mini Bikes are meant for use only in controlled environments free of potential traffic hazards and not on public streets or sidewalks. Do not ride your electric mini bike in any areas where pedestrian or product traffic is present.

**Do not activate the speed control on the hand grip unless you are on the electric mini bike and in a safe, outdoor environment suitable for riding.**

# Safety Warnings

These bikes were manufactured for performance and durability but are not impervious to damage. Jumping or other aggressive riding can over-stress and damage any product, including the electric motorbike, and the rider assumes all risks associated with high-stress activity.

Be careful and know your limitations. Risk of injury increases as the degree of riding difficulty increases. The rider assumes all risk associated with aggressive riding activities.

Maintain a hold on the handlebars at all times.

Never carry passengers or allow more than one person at a time to ride the electric mini bike.

Never use near steps or swimming pools.

Keep your fingers and other body parts away from the drive chain, steering system, wheels and all other moving components.

Never use headphones or a cell phone when riding.

Never hitch a ride with another vehicle.

Do not ride the vehicles in wet or icy weather and never immerse the electric mini bike in water, as the electrical and drive components could be damaged by water or create other possibly unsafe conditions. These vehicles are intended for use on flat, level ground without loose debris such as rocks or gravel. Wet, slick, bumpy, uneven or rough surfaces may impair traction and contribute to possible accidents. Do not ride the electric mini bike in mud, ice, puddles or water. Avoid excessive speeds that can be associated with downhill rides. Never risk damaging surfaces such as carpet or flooring by use of an electric mini bike indoors. Do not ride at night or when visibility is limited.

## PROPER RIDING ATTIRE

Always wear proper protective equipment such as an approved safety helmet (with chin strap securely buckled). A helmet may be legally required by local law or regulation in your area. Elbow pads and knee pads, a long-sleeved shirt, long pants and gloves are recommended. Always wear athletic shoes (lace-up shoes with rubber soles), never ride barefooted or in sandals, and keep shoelaces tied and out of the way of the wheels, motor and drive system.

## USING THE CHARGER

The charger supplied with the electric mini bike should be regularly examined for damage to the cord, plug, enclosure and other parts, and in the event of such damage, the bike must not be charged until the charger has been repaired or replaced.

- Use only with the recommended charger. **Do not** use Lead-Acid charger with Li-ion battery and vice versa.
- **Lead acid** Battery use **Burromax** Charger # LS-018C20-2401500.
- **Li-ion Battery** use **Burromax** charger # LS-018C20- 2945000
- Use caution when charging. The charger is not a toy and should be operated by an adult.
- Do not operate charger near flammable materials.
- Unplug charger and disconnect from bike when not in use.
- Chargers are not waterproof and should never be used in wet conditions. Serious injury or death could result.
- **FAILURE TO USE COMMON SENSE AND HEED THE ABOVE WARNINGS INCREASES RISK OF SERIOUS INJURY. USE WITH APPROPRIATE CAUTION AND SERIOUS ATTENTION TO SAFE OPERATION.**

# Before You Begin

Remove contents from box. Remove the foam separators that protect the components from damage during shipping. Inspect the contents of the box for scratches in the paint, dents or kinked cables that may have occurred during shipping. Because these vehicles are 95 percent assembled and packed at the factory, there should not be any problems, even if the box has a few scars or dents.

**MAKE SURE POWER SWITCH IS TURNED "OFF" BEFORE CONDUCTING ANY MAINTENANCE PROCEDURES.**

**Burromax** recommends assembly and maintenance by an adult. Allow up to 30 minutes for assembly.

**Standard model TT250** allow up to 12 hours for initial charge (see page 6 & 8 for charging information).

**Li-ion Model TT350R** Allow up to 4 hours for initial charge (See page 7 & 8 for charging information)

During assembly, you can familiarize yourself with the vehicles components and design. Enjoy the process and take your time to insure all components are safe and secure!

## Required Tools



4mm and 5mm and  
6mm Hex Key  
wrenches (Included)



10mm, 12mm 14mm  
and 17mm open  
wrench (Included)



Screwdriver  
(included)



30-45° Air Chuck

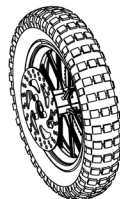

Your local Service Stations will have this item

## **WARNING:**

**DO NOT USE NON-Burromax PRODUCTS WITH YOUR Burromax Vehicles.** These Vehicles have been built to certain **Burromax** design specifications. The original equipment supplied at the time of sale was selected based on its compatibility with the frame, fork and all other parts. Certain aftermarket products may or may not be compatible and may void your warranty.

# Assembly and Set-Up

## Attaching the Handlebars

**Tools required:** 6mm Hex Key wrench

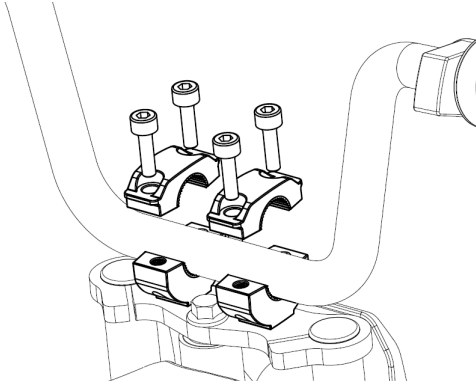

**1.** Place the handlebars in the handlebar clamps. Make sure cables are not twisted or kinked.

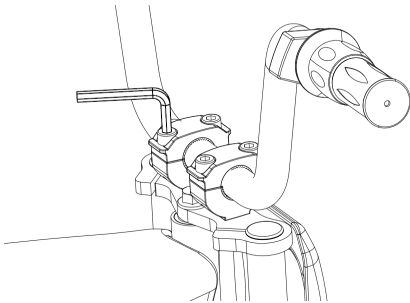

**2.** Center handlebar in clamps and position to fit the rider height. Tighten the bolts using a 6mm Allen wrench. When properly tightened, you should have a small gap in front and back of each clamp. The handlebars should not move forward or back.

**3.** Rotate the front fork from side to side making sure that the wires and cable are free. Squeeze the brake handle a couple times to loosen up the brake. Spin the rear wheel making sure it spins free. Without brake drag.

## **!** WARNING:

Failing to properly adjust and tighten the bolts that affix the handlebars can cause you to lose control and crash.

**Turn power switch “OFF” before conducting any maintenance procedures.**

All Models are preset on slow speed at the factory see page 15 for information on the **Hi - slow** speed switch and the **Sport** option.

**TT350R** - light switch is located on the throttle control.

**TT250** - Battery charge indicator is located on throttle control

# Assembly and Set-Up

## Inflating the Tires

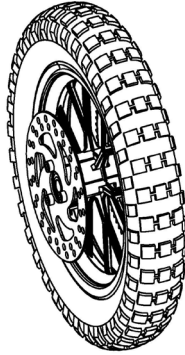

Tires are partially inflated when shipped, but they invariably lose some pressure between the point of manufacturing and your purchase. Using a 45 degree tire chuck, inflate both tires 40-50 PSI. We strongly recommend 50 PSI for adults up to 250lb when using this product. Proper Tire pressure is VERY IMPORTANT. DO not squeeze the tire and assume it is correct. For the best performance and range this must be checked regularly—Low tire pressure reduces range and speed.

Please Note: There is a tire information label located on the left side of the rear fork with this information as well.

**Note:** All Burromax electric ride on bikes are set on **slow speed** when they are shipped. You should change this setting only when you feel the rider can control the vehicle at higher speeds.

**⚠ WARNING:**  
Make sure power switch is in off position before performing any maintenance.

**Note:** The pressurized air supplies found at gasoline stations are designed to inflate high-volume automobile tires. If you decide to use such an air supply to inflate your tires, first make sure the pressure gauge is working, then use very short bursts to inflate to the correct PSI. If you inadvertently over-inflate the tire, release the excess pressure immediately.

# BEFORE RIDING

## The Lead-Acid Battery

Your new electric mini bike is partially charged from the factory and ready for the first ride.

### Standard Lead-Acid TT250

To achieve the best performance and life from your new battery, the first charge and full discharge cycles are important. Run the battery down (not dead) and then recharge completely. This will format the battery. To get the longest life out of your lead-acid batteries recharge them after every ride, even very small rides. Leaving the battery pack in a partially discharged state may cause internal sulfation of the batteries which lowers the useful lifespan of the batter pack.

- Initial charge time up to 12 hours
- Recharge time: up to 8 hours, depending on level of depletion.
- Fully charge battery before storing.
- When the minibike is not in regular use, recharge the battery at least once a month until normal use is resumed.

### Standard Charger # LS-018C20-2401500 Lead-Acid Battery

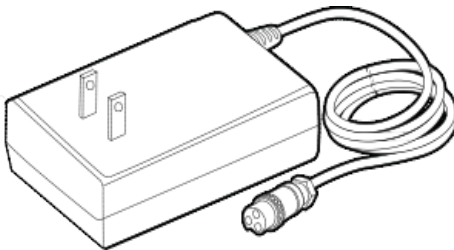

**Note:** Make sure power is turned **OFF** when unit is not in use. If the power switch is left on for an extended period, the battery may reach a stage at which it will no longer hold a charge.

### **WARNING:**

Rechargeable batteries are only to be charged under adult supervision. Always disconnect your electric mini bike from the charger before cleaning with liquid.

**Note:** If your charger does not look like the one illustrated, your unit may have been supplied with an alternative charger. The specifications and charging procedure would not change.

The charger has a small window with one LED to indicate the charge status. Refer to the illustration on the charger unit for the actual "charging" and "charged" status indications for your model charger. Chargers have built-in overcharge protection to prevent battery from being overcharged. Charger will get warm during use. This is normal for some chargers and is no cause for concern. If your charger does not get warm during use, it does not mean that it is not working properly. You should

**Turn power switch "OFF" before charging and conducting any maintenance procedures.**

**Note:** Make sure power is turned **OFF** when unit is not in use. If the power switch is left on for an extended period, the battery may reach a stage at which it will no longer hold a charge.

# BEFORE RIDING

## The Lithium-ion battery

Your new electric mini bike is partially charged from the factory. Before the first ride you should charge the battery for at least 4 hours to ensure a full charge.

The Lithium Battery offers you less weight, 1/3 the weight of similar size lead acid battery

Longer run times, Approx. twice as long as lead acid battery

Shorter charging times, partial charge okay, fully recharge in 3 hours. 75% charge in 1-1/2 hour. No need to cycle the battery, it has no memory.

Longer life. 500 charge and discharge cycles. A more environmentally friendly battery.

The Li-ion battery and charger are to be used together. Do not mix with Lead-acid battery or charger. Use only **Burromax** battery chargers.

This battery when run completely down below cut off voltage, it might be necessary to disconnect the battery and then reconnect before the battery will recharge

Do not store or charge the battery in extreme temperatures. Above 110° F or below 0° F

## Lithium-ion battery charger

# LS-018C20- 2945000

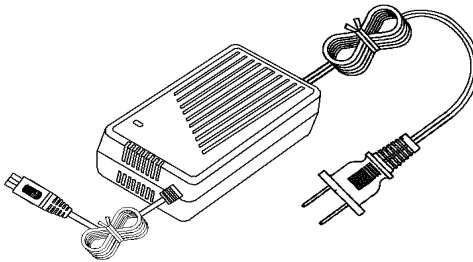

## **WARNING:**

- Do not charge or discharge the battery in extreme temperatures. Above 110° F or below 0° F
- Do not short-circuit the positive (+) and negative (-) terminals of the battery.
- Do not immerse the battery into liquids or allow it to get wet.
- The battery should be stored in a cool, dry area. store with partial charge of 50% do not store with a full charge. Discharging and recharging the battery every 6 months is recommended.
- Keep away from fire.
- Do not disassemble the battery Do not use Lead Acid or automotive battery chargers as it will damage the battery and void your warranty.

Battery charger is not water proof. Water and moisture will damage the charger. Always use charger in a clean, dry and cool area.

**Turn power switch "OFF" before charging battery or conducting any maintenance procedures.**

# BEFORE RIDING

## Charging the Battery

Run time may vary depending on many factors such as riding conditions, rider weight, climate and/or proper maintenance, specifically Tire Pressure.

**Lead-Acid Full recharge in 6 to 8 hours.** Average battery life: 250 charge/discharge cycles. To get the longest life out of your batteries recharge them after every ride. Leaving your batteries in a partially discharged state can cause internal sulfation which lowers the performance and life of the battery pack. Do not charge in extreme temperature above 110 F or below 32 F

**Li-ion battery Full recharge about 3 hours**

Average battery life-500 recharge cycles. Li-ion does not require full recharge. Partial charge and not fully discharging the battery has little effect on battery life. Charging in extreme temperatures above 110 F and below 32 F can cause damage to battery. Always store in cool dry area with no more than 50% charge

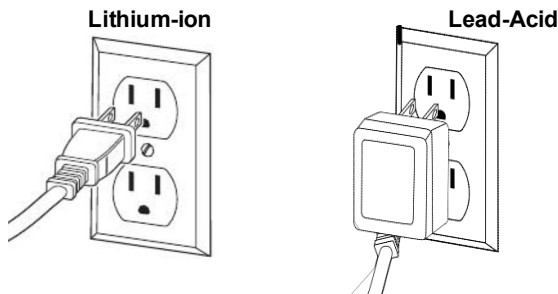

**1.** Plug the charger into a wall outlet **FIRST**. If the lights on charger do not light up, check the power to the outlet. If necessary, try a different outlet.

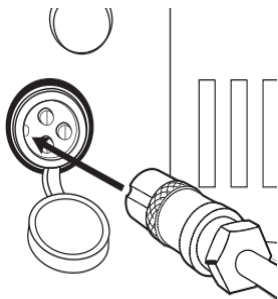

**2.** Make sure Mini bike power switch is **OFF** before charging. **AFTER** the Green light comes on located on the charger you can plug the charger into the charger port to charge battery.

Align Plug and Socket correctly! Plug should slip in socket without excessive force. The green light indicates on and or fully charged. Red light indicates Charging

**! WARNING:** Failure to recharge the Lead-Acid battery at least once a month may result in a battery that will no longer hold a charge.

**Turn power switch "OFF" before conducting any maintenance procedures.**

**! WARNING:** Lead acid and li-ion battery chargers are not interchangeable. Make sure you are using the correct charger for the battery type you have. Serious damage could result

**Use only Burromax recommended battery type used!**

**! WARNING:** The Li-ion battery charger is a fan cooled smart charger. Always use in a clean dry environment. Dirt and moisture will damage the charger

# Repair and Maintenance

**Warning:** Turn power switch “OFF” before conducting any maintenance procedures.

## Adjusting the Brakes

**Tools required:** 5mm Hex Key wrench

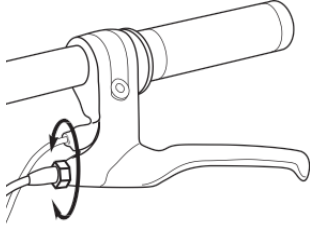

**1.** To adjust the tension, thread the brake lever adjuster in or out 1/4 to 1/2 turn until the desired brake adjustment is attained. Most adjustments are complete at this step. If brake still needs further adjustment, proceed to step 2.

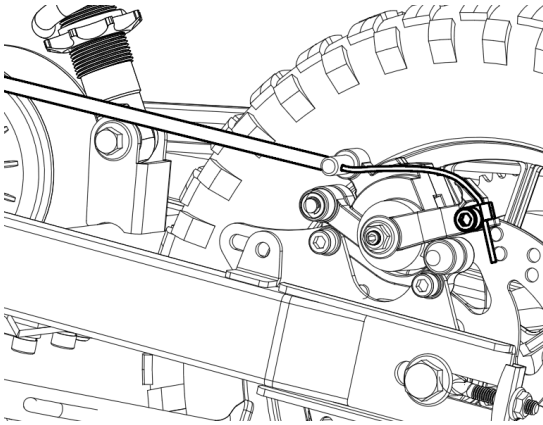

**2.** If the brake has too much slack, use a 5mm Hex Key wrench to loosen the brake anchor cable for additional adjustment.

## Testing the Brakes

To use the brake, squeeze the lever to increase the pressure on the brake. The brake lever is fitted with a cable adjuster to compensate for cable stretch and/or to fine-tune the lever movement to brake engagement. If brake is not engaging properly, follow instructions for adjusting the brakes, make sure brakes is NOT adjusted to tight.

## **!** WARNING:

The brake can cause the electric motorbike to skid the tire throwing an unsuspecting rider. Practice in an open area free from obstacles until you are familiar with the brake function. Avoid skidding to a stop as this can cause you to lose control or damage the rear tire.

**Note:** Brakes adjusted to tight and dragging will cause excessive wear and poor performance.

## **!** WARNING:

To avoid a pinch or injury, keep fingers away from moving sprockets and chain.

# Repair and Maintenance

## Chain adjustment, Rear Tire and chain Replacement

**Tools required:** Screwdriver, 5mm hex key wrench, 10mm, 12mm and 17mm wrench

1. Loosen screws and remove chain guard.

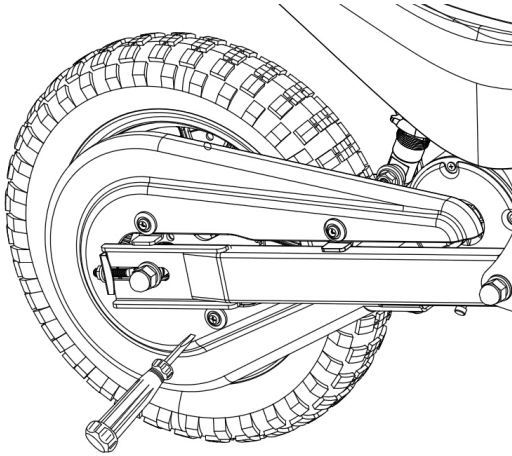

2. With a 5mm Hex Key wrench remove Brake Mounting Plate adjuster screw (A). Loosen the brake cable anchor bolt and remove cable (B) If replacing tire also remove 2 Brake caliper mounting bolts (C) (5mm Hex Key) and remove caliper.

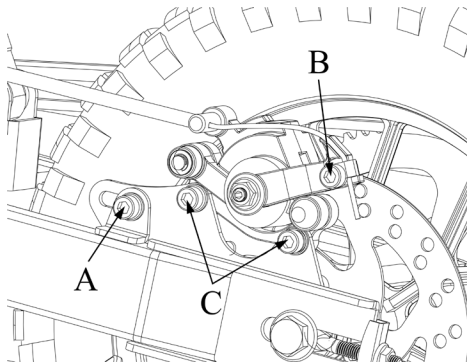

**⚠ WARNING:**  
Make sure power switch is in off position before performing any maintenance.

**⚠ WARNING:**  
To avoid a pinch or injury keep fingers away from moving sprockets and chain.

# Repair and Maintenance

## Chain adjustment, Rear Tire and chain Replacement

3. With 12mm and 17mm wrenches, loosen the axle. Remove the rear axle and remove the chain from the sprocket--pull the wheel out.

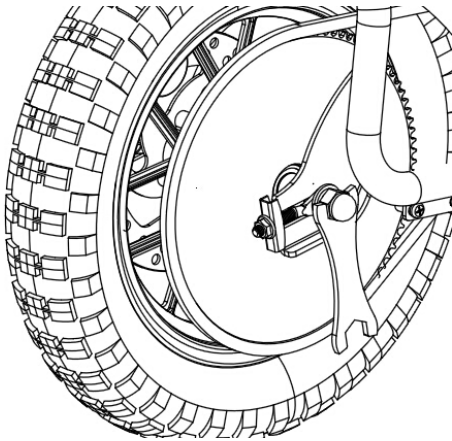

Replacing the chain requires removal of a Master Link. Removing outer retainer allows this link to be removed. Be careful not to damage clip. Note. Install clip as shown

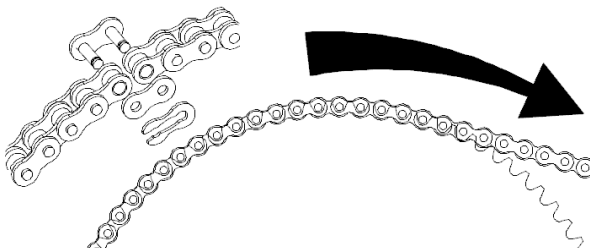

### **!** WARNING:

Do not activate the speed control on the hand grip unless you are on the electric mini bike and in a safe, outdoor environment suitable for riding.

### **!** WARNING:

make sure power switch is in off position before performing any maintenance.

### **!** WARNING:

To avoid a pinch or injury, keep fingers away from moving sprockets and chain.

# Repair and Maintenance

Note the sequence of the hardware for assembly

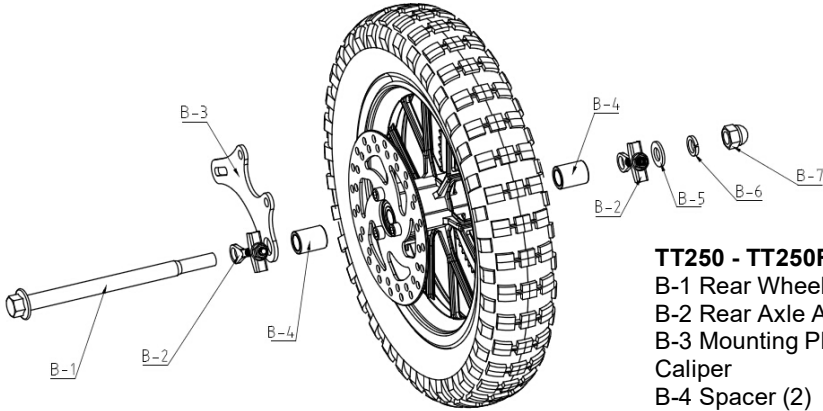

## TT250 - TT250R – TT350R

- B-1 Rear Wheel Axle
- B-2 Rear Axle Adjuster (2)
- B-3 Mounting Plate-Brake Caliper
- B-4 Spacer (2)
- B-5 Flat Washer
- B-6 Lock Washer
- B-7 Acorn Nut

**4.** Install the new chain or wheel by slipping the chain around the axle. Slide the axle with hardware into the slots on the frame. Maneuver the chain onto the sprocket on the rear wheel and motor.

**5.** Tighten chain adjusters using 10mm wrench evenly to remove some slack from the chain as required.

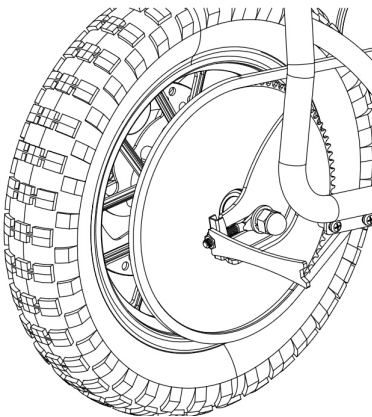

**⚠ WARNING:**  
make sure power switch is in off position before performing any maintenance.

**⚠ WARNING:**  
To avoid a pinch or injury, keep fingers away from moving sprockets and chain.

# Repair and Maintenance

6. Adjust chain tension to have approx. 1/2" of free play. Free play is not forced! The chain should move this amount with very little force. Using 12mm and 17mm wrenches tighten axle securely. Chain tension must be correct with axle tightened securely (fig A). Snug chain adjuster bolts after axle is tight.

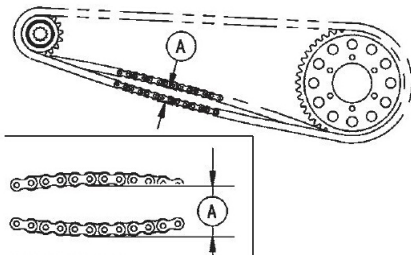

7. Thread the cable wire into the cable anchor. Install the cable to its original position and tighten securely.

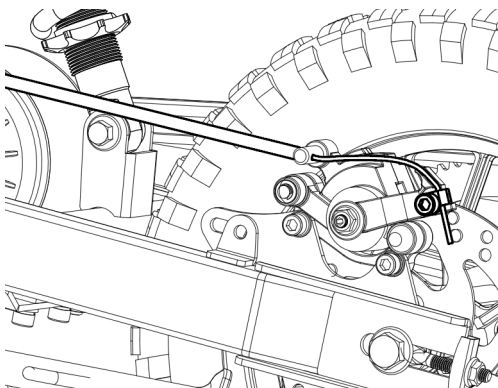

8. Tighten the brake mount plate bolts (A) and (C) securely. Re-attach the chain guard. Test ride. Readjust as needed.

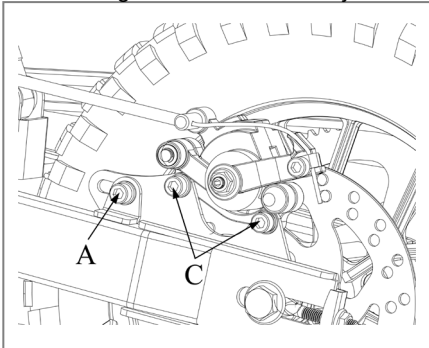

## Chain and Sprocket

### Notes

The chain will typically have a "loose spot" and "tight spot" corresponding with a sprocket rotational position. This is normal and common to all chain-driven products due to run-out tolerances of the sprockets. The chain should be adjusted to the ideal tension with chain in the tightest spot.

Proper chain alignment must be maintained. The wheel must not be skewed. If the chain is noisy or rough running, check the lubrication, tension and alignment of the sprockets, in that order.

### WARNING:

To avoid a pinch or injury keep fingers away from moving sprockets and chain.

### WARNING:

make sure power switch is in off position before performing any maintenance.

# Repair and Maintenance

## Replacing the Fuse lead-acid Battery (ONLY)

1. Remove two M5 screws removing the battery cover from right side. Remove battery strap and slide battery set out.
2. Locate the fuse box attached to the batteries. Open the fuse cover to expose the fuse.
3. Remove the fuse and replace with a new one of equal amperage. A small spark may occur when install the new fuse. Requires 30-amp fuse. Close the fuse cover and reattach the battery cover.

## Battery Replacement

**Lead-Acid** batteries (2-12v 7ah) should be replaced in sets only and with original **Burromax** Batteries!

**Li-ion** battery (1-24v 10ah). Non-replaceable internal breaker Only use the **Burromax Li-ion** battery and **Li-ion** Battery charger together.

**Retailers do not have the same quality as our OEM batteries. Performance may be seriously affected!**

1. With battery cover removed disconnect hold down strap.
2. Slide battery set out of mounting tray.
3. Disconnect battery connection. Re-install new battery set and reconnect.
4. When reconnecting new battery set you may get a small spark.
5. Tuck in wires and reassemble.

Lithium-ion Battery

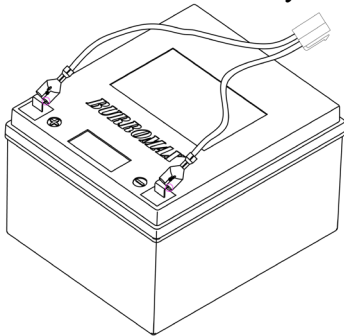

Lead-Acid Battery

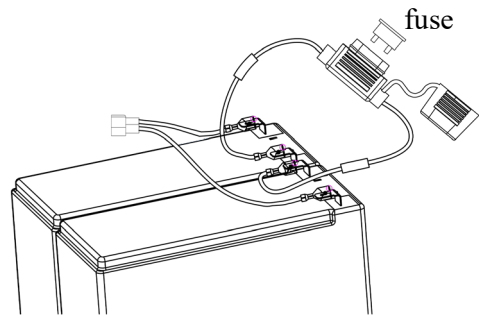

### WARNING:

Make sure power switch is in off position before performing any maintenance.



### WARNING:

To prevent shock, please follow the instructions accordingly and do not skip or combine any steps.

**Note:** Li-ion battery and Lead acid battery may be interchanged in the TT250 models but you must use the correct charger with the battery used.

# Repair and Maintenance

## Safety Speed Limiter Switch and Sport option

All Burromax electric ride on bikes are set on slow speed when they are shipped. You should change this setting only when you feel the rider can control the vehicle at higher speeds.

To switch from **slow** speed to **High** speed does not require the removal of the side cover—Please see below

1. **Hi-Slow** speed switch is hidden under the battery cover as shown below. There is a small hole in the top of the battery side cover. Insert a small tool the size of a toothpick and Move front to back this will select the switch to your desired position. "O" for Hi speed and "1" for **slow** speed. If you cannot adjust this setting through this hole with LIGHT PRESSURE. Please remove the side cover and the switch will be very apparent.

On the **high**-speed setting. **TT250** has a top speed of approx. 14 mph. The **TT250R** has a top speed of approx. 15 mph. The **TT350R** has a top speed of 17 mph.

**⚠ WARNING:**  
make sure power switch is in off position before performing any maintenance.

**Note: All vehicles are shipped with the speed limited in the Slow Position!**

**Note:** when Switch is in the **slow** position the **Sport** option does not work

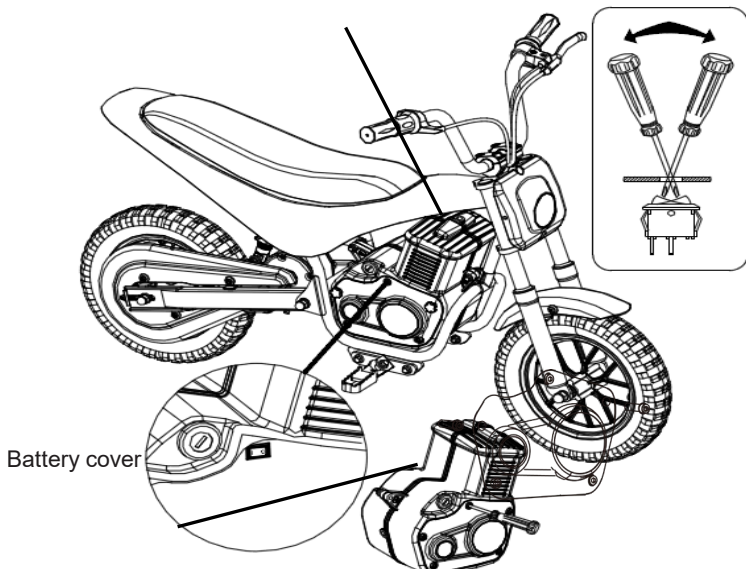

# Repair and Maintenance

## Battery Care and Disposal (Lead-Acid)

Do not store the battery in temperatures above 110 ° F or below 32° F.



CONTAINS SEALED  
NON-SPILLABLE LEAD-ACID  
BATTERIES. BATTERIES  
MUST BE RECYCLED.

**Disposal:** Burromax product uses sealed lead-acid batteries which must be recycled or disposed of in an environmentally sound manner. Do not dispose of a lead-acid battery in a fire. The battery may explode or leak. Do not dispose of a lead-acid battery in your regular household trash. The incineration, land filling or mixing of sealed lead-acid batteries with household trash is prohibited by law in most areas. Return exhausted batteries to a federal or state approved lead-acid battery recycler or a local seller of automotive batteries.

## Battery Care and Disposal (Lithium-ion)

Do not store the battery in temperatures above 110° F or below 0° F. Always store with no more than a 50% charge. Keep away from extreme heat as it will diminish the performance and life of your **Burromax** Li-ion Battery. Return exhausted batteries to a federal or state approved lead-acid battery recycler or a local seller of automotive batteries.

## Charger care and disposal

The charger supplied with the bike should be regularly examined for damage to the cord, plug, enclosure and other parts, and, in the event of such damage, the mini bike must not be charged until it has been repaired or replaced  
Charger should be recycled or disposed of in an environmentally sound way.

- **For Lead-Acid Battery Use Burromax Charger**
- # LS-018C20-2401500.
- **For Li-ion Battery use Burromax Charger**
- # LS-018C20- 2945000

See [www.burromax.com](http://www.burromax.com) for ordering

## Electric Mini Bike disposal

Electric Mini Bike must be recycled or disposed of in an environmentally sound manner.

## **WARNING:**

If **Lead-Acid** battery leak develops, avoid contact with the leaking acid and place the damaged battery in a plastic bag. Refer to the disposal instructions at left. If acid comes into contact with skin or eyes, flush with cool water for at least 15 minutes and contact a physician.

## **WARNING:**

**Lead-Acid** Batteries, posts, terminals and related accessories contain lead and lead compounds. **Wash your hands after handling.**

## **WARNING:**

**Lithium-ion** Batteries

- Do not charge or discharge the battery in extreme temperatures.
- Do not short-circuit the positive (+) and negative (-) terminals of the battery.
- Do not immerse the battery into liquids or allow it to get wet.
- The battery should be stored in a clean, dry area. Discharging and recharging the battery every 6 months is recommended.
- Keep away from fire.
- **Do not disassemble the battery**

# Troubleshooting Guide

| Problem  | Possible Cause                           | Solution  |
|--|--|---|
| Mini bike does not run                           | Undercharged battery                     | Charge the battery. A new <b>Lead-Acid</b> battery should have been charged for at least 12 hours and up to 8 hours after each subsequent use depending upon depletion.   |
|  | Loose wires or connectors                | <p>New <b>Li-ion</b> battery should be charged for at least 4 hours for full charge. Short charging times are okay after initial charge. This battery when run completely down below cut off voltage maybe necessary disconnect and reconnect before the battery will recharge</p> <p>Check all wires and connectors making sure they are secure. Look for broken or loose wires and connections.</p> <p>On lead acid batteries check the fuse for being burned out. Replace with same amperage fuse.</p> |
| Mini bike was running but suddenly stopped       | Burned-out fuse (lead-acid Battery only) | An excessive overload, such as too heavy a rider or too steep a hill, could cause the motor to overheat. Replace the fuse with a new one of equal amperage. Correct the conditions that caused the fuse to burn out and avoid repeatedly burning out fuse.  |
|  | Motor or electrical switch damage        | Contact your local <b>Burromax</b> authorized dealer for diagnosis and repair.  |
| Short run time (less than 15 minutes per charge) | Undercharged battery (Lead acid)         | Charge the battery. A new <b>Lead-Acid</b> battery should have been depleted and charged for at least 12 hours and up to 8 hours after each subsequent use.   |
|  | (Lithium-ion) battery                    | Charge the Battery. A new <b>Li-ion</b> battery should be charged at least 4 hours and up to 2 hours for 80% charge   |
|  | Charger not working properly.            | Make sure the charger is securely connected and red indicator light is on when charging and the green light is on when fully charged  |

# Troubleshooting Guide

| Problem  | Possible Cause  | Solution  |
|--|---|---|
| Short run time (less than 15 minutes per charge)             | Battery is old and will not accept full charge                              | Even with proper care, a rechargeable battery does not last forever. Average SLA battery life, 1 to 2 years-300 cycles<br>Li-ion battery life, 3 to 4 years-600 cycle<br>Replace only with OEM <b>Burromax</b> replacement battery. |
|  | Tires are not properly inflated   | The tires are inflated when shipped but they invariably will lose some pressure between the point of manufacturing and your purchase. Refer to instructions on <b>page 5</b> of this manual to properly inflate tires.              |
|  | Brakes are not adjusted properly  | Refer to brake adjustment instructions on <b>page 9</b> of this manual.   |
| Mini bike runs sluggishly                                    | Riding conditions are too stressful   | Use only on solid, flat, clean and dry surfaces such as pavement or level ground.   |
|  | Tires are not properly inflated   | The tires are inflated when shipped, but they invariably will lose some pressure between the point of manufacturing and your purchase. Refer to instructions on <b>page 5</b> of this manual to properly inflate tires.             |
|  | Mini bike is overloaded   | Make sure you do not overload the mini bike by allowing more than one rider at one time, exceeding the maximum weight limit, going up too steep a hill or towing objects behind the vehicle.  |
|  | 2 speed switch in the slow position<br>Brake adjusted to tight and Dragging | Refer to <b>page 15</b> for switching instructions.<br><br>Refer to <b>page 9</b> for brake adjustment  |
| Sometimes the Mini bike doesn't run, but other times it does | Loose wires or connectors   | Check all wires around the motors and all connectors to make sure they are tight.   |
|  | Motor or electrical switch damage   | Contact your local authorized <b>Burromax</b> dealer for diagnosis and repair.  |

# Troubleshooting Guide

| Problem   | Possible Cause                                | Solution  |
|---|---|---|
| Charger gets warm during use                    | Normal response to charger use                | No action required. This is normal and is no cause for concern. If your charger does not get warm during use, it does not mean that it is not working properly. |
| Mini bike does not stop when applying the brake | Brakes are not adjusted properly              | Refer to instructions on <b>page 9</b> of this manual to properly adjust brakes.  |
| Mini bike makes loud noises or grinding sounds  | Chain is too dry and or not adjusted properly | Apply a lubricant such as 3 in 1™ or Tri-Flow™ or motorcycle chain lube the chain. Refer to <b>page 10-13</b> for adjustment and alignment instruction          |

**NOTICE:** When the Lithium battery has been run down (depleted) below the cut off voltage of 21v it may be necessary to disconnect the battery and then reconnect to get the battery to recharge. Care should be given to the lithium battery. Charging in extreme heat or cold will damage the battery and shorten the life. The battery charger is not waterproof. Moisture and water will damage the working of your charger. Always use in a cool, dry and clean environment.

# TT250 Side View

## TT250 Main Components

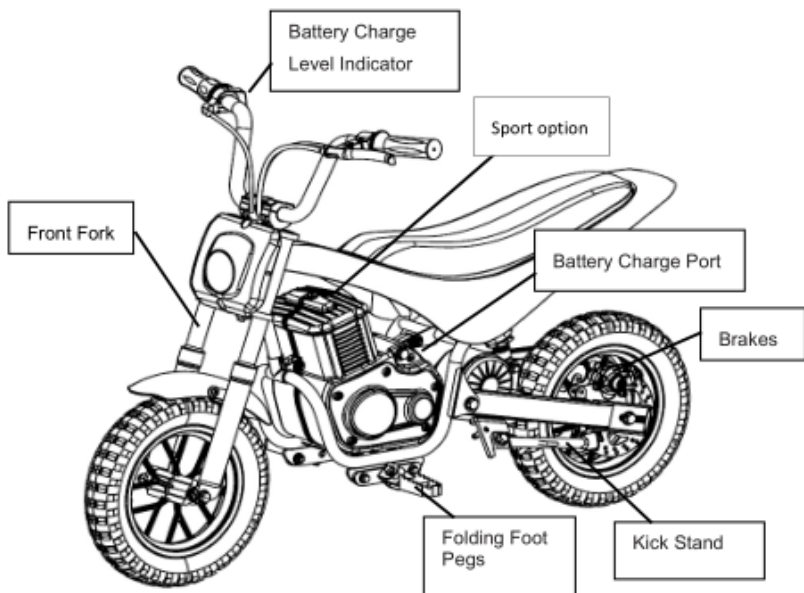
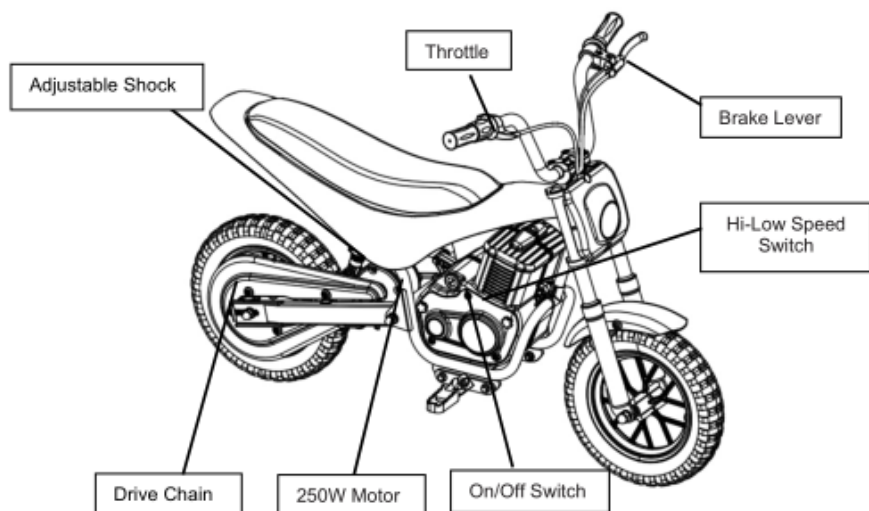

# TT250R – TT350R Side View

## TT250R – TT350R Main Components

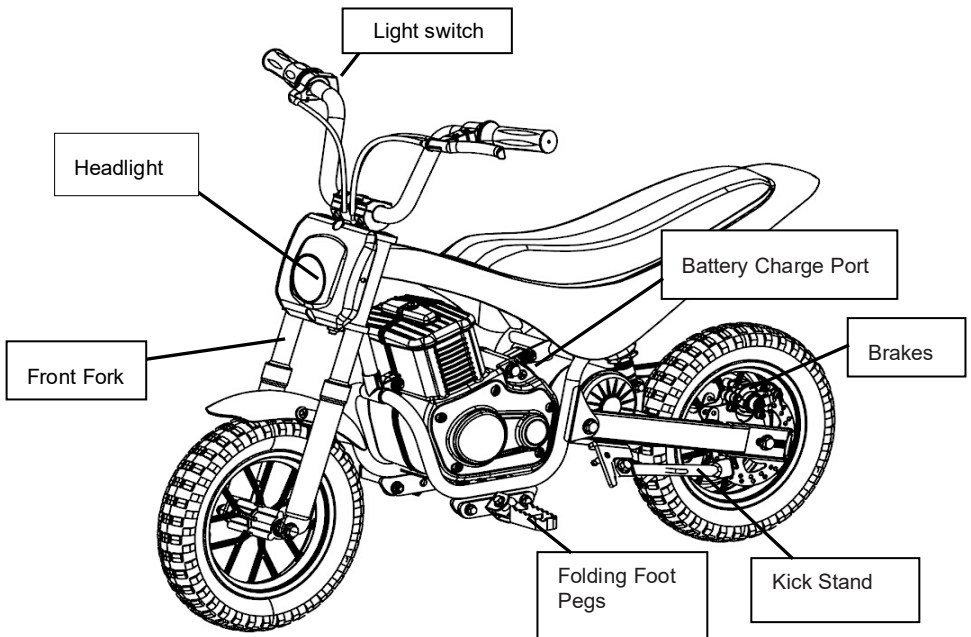
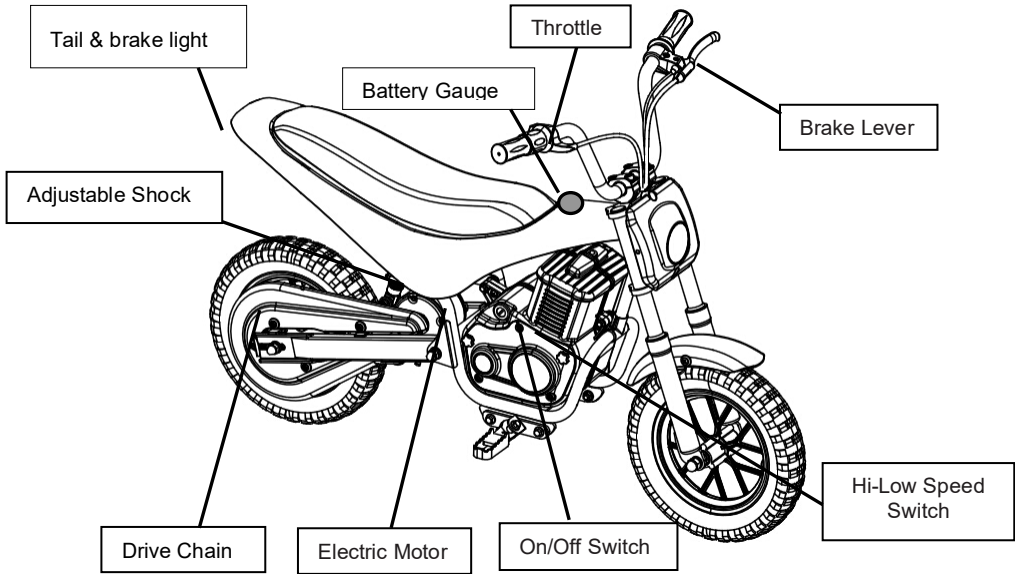

# TT250 Electrical Diagram

## Electrical Schematics

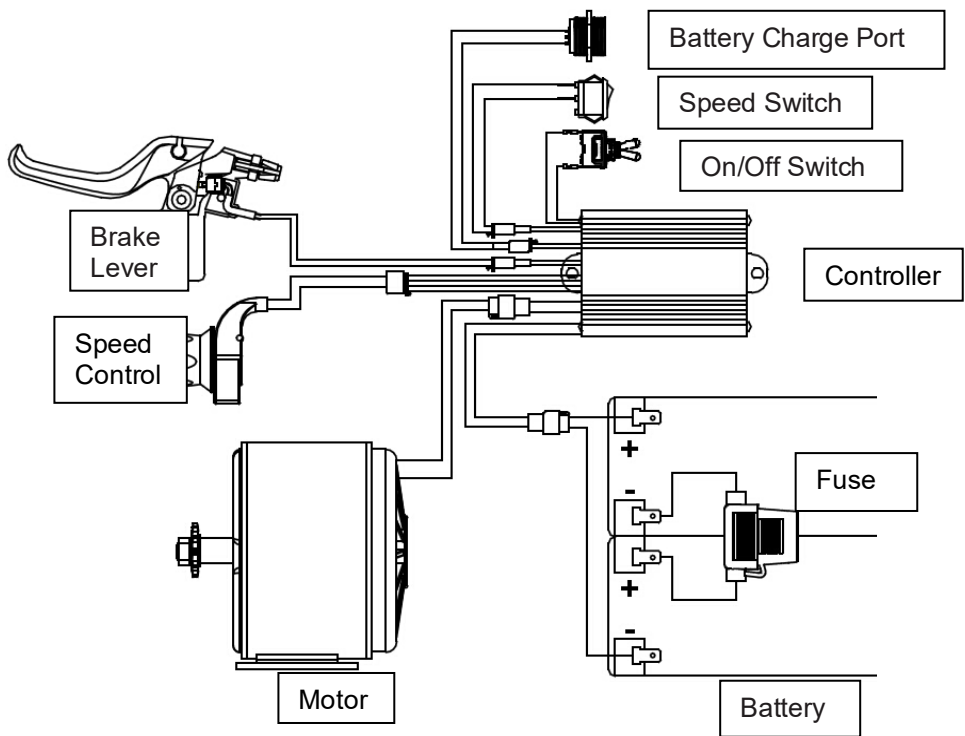

# TT350R Electrical Diagram

## Electrical Schematics

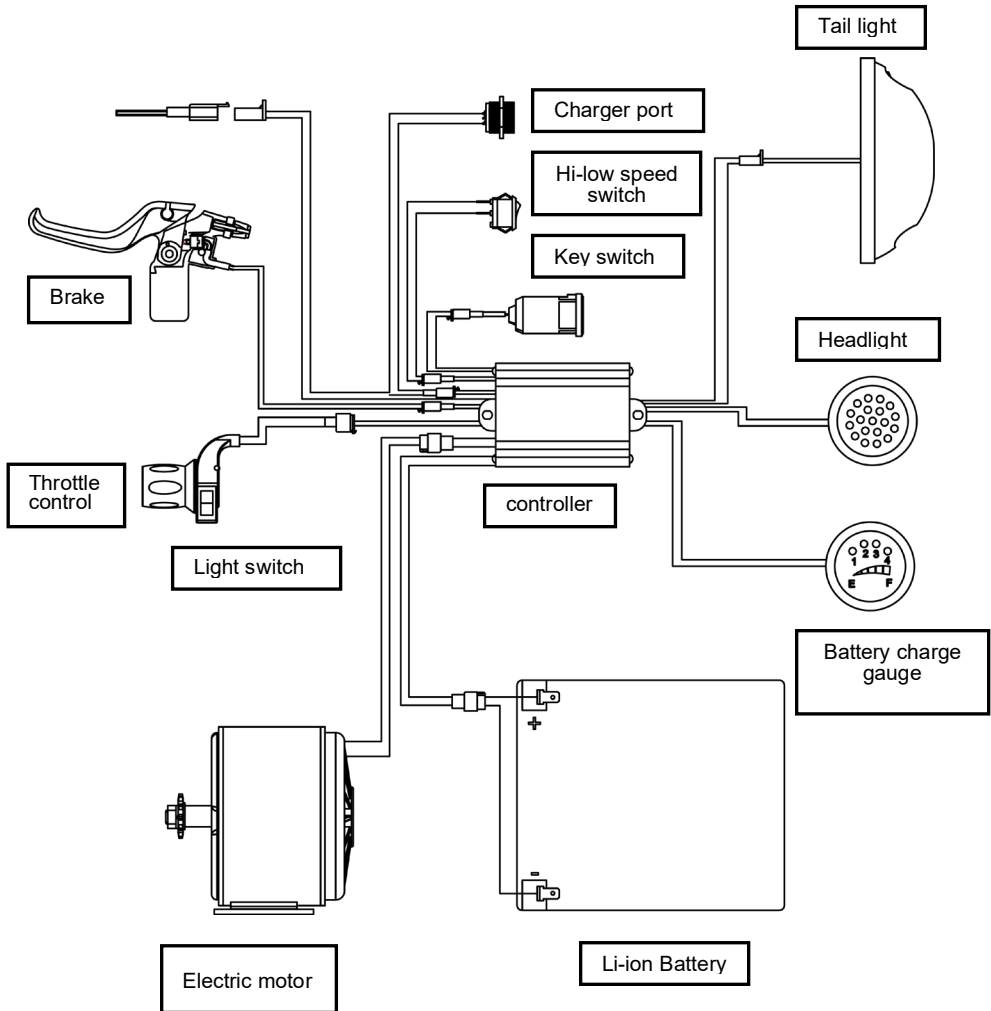

# Safety reminders

## PRE-RIDE CHECKLIST

### Loose Parts

Check and secure all fasteners before every ride. Make sure handlebar clamp bolts are locked properly in place. There should not be any unusual rattles or sounds from loose parts or broken components. If you are not sure, ask an experienced mechanic to check.

### Brake

Check the brake for proper function. When you squeeze the lever, the brake should provide positive braking action. When you apply the brake with the speed control on, the brake cut-off switch will stop the motor. When the brake is not in use, the rear wheel should spin freely without drag.

### Frame, Fork and Handlebars

Check for cracks or broken connections. Although broken frames and chassis components are rare, it is possible for an aggressive rider to run into a curb or wall and wreck, bend or break a frame, fork or suspension components. Get in the habit of inspecting yours regularly.

### Tire Inflation

Tires are inflated when shipped, but they invariably lose some pressure between the point of manufacturing and your purchase. Using a bicycle tire pump equipped for a Schrader valve, inflate both tires to 40-50 PSI. Heavier riders use 50 PSI. This information is also located on the left side of the rear fork for easy access. Periodically inspect the tires for excess wear, and regularly check the tire pressure and re-inflate as necessary. If you get a flat tire, a new tube can be purchased online at [WWW.Burromax.com](http://WWW.Burromax.com)

### Safety Gear

Always wear proper protective equipment such as an approved safety helmet, elbow pads and knee pads. Always wear athletic shoes (lace-up shoes with rubber soles), never ride barefooted or in sandals, and keep shoelaces tied and out of the way of the wheels, motor and drive system.



Do not use this product for the first time until you have fully charged the battery and inflated the tires to the correct PSI.

Please read this manual thoroughly. Failure to follow these instructions may damage your product and void your warranty.

# Warranty

## **Burromax Limited Warranty**

The manufacturer warrants this product to be free of manufacturing defects for a period of 1 year from date of purchase. This Limited Warranty does not cover normal wear and tear, tires, tubes, cables or any damage, failure or loss caused by improper assembly, maintenance, or storage or use of these products. Batteries are pro-rated after 6 Months from date of purchase

This Limited Warranty will be void if the product is ever:

- used in a manner other than for recreation or transportation;
- modified in any way;
- rented.

The manufacturer is not liable for incidental or consequential loss or damage due directly or indirectly to the use of this product.

**Burromax** does not offer an extended warranty. If you have purchased an extended warranty, it must be honored by the store at which it was purchased. For your records, save your original sales receipt with this manual, Fill Out the product registration page and mail it to:  
**Burromax**  
1200 Reco Ave  
Crestwood, MO 63126

All Warranty request will be evaluated by **Burromax** and final determination will be made at our sole discretion.

# Product Registration

Name \_\_\_\_\_ Age \_\_\_\_\_

Address \_\_\_\_\_

City \_\_\_\_\_ State \_\_\_\_\_

Zip \_\_\_\_\_

Home Phone \_\_\_\_\_

Work Phone \_\_\_\_\_

Email \_\_\_\_\_

Purchase Date \_\_\_\_\_ Purchased from \_\_\_\_\_

Serial Number \_\_\_\_\_

Male/Female Rider? \_\_\_\_\_

Is this your first **Burromax** product? \_\_\_\_\_

Other similar product owned before \_\_\_\_\_

How did you hear about the Product? \_\_\_\_\_

PLEASE FILL OUT AND MAIL TO.

**Burromax** LLC.

1200 Reco Ave

Crestwood, MO 63126

REDGISTER ONLINE AT

[WWW.BURROMAX.COM](http://WWW.BURROMAX.COM)

WE WELCOME YOUR COMMENTS AND SUGGESTIONS FOR  
**BURROMAX** PRODUCTS

# Product Registration

Name \_\_\_\_\_ Age \_\_\_\_\_

Address \_\_\_\_\_

City \_\_\_\_\_ State \_\_\_\_\_

Zip \_\_\_\_\_

Home Phone \_\_\_\_\_

Work Phone \_\_\_\_\_

Email \_\_\_\_\_

Purchase Date \_\_\_\_\_ Purchased from \_\_\_\_\_

Serial Number \_\_\_\_\_

Male/Female Rider? \_\_\_\_\_

Is this your first **Burromax** product? \_\_\_\_\_

Other similar product owned before \_\_\_\_\_

How did you hear about the Product? \_\_\_\_\_

PLEASE FILL OUT AND MAIL TO

**Burromax** LLC.

P.O. BOX 220939

ST LOUIS, MO 63122

REDGISTER ONLINE AT

[WWW.BURROMAX.COM](http://WWW.BURROMAX.COM)

WE WELCOME YOUR COMMENTS AND SUGGESTIONS FOR  
**BURROMAX** PRODUCTS

# Burromax Electric Mini Bike

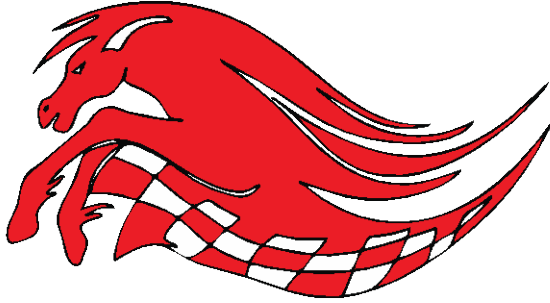

**BURROMAX**<sup>TM</sup>

