



**XT SERIES:
150, 200, D-200
250, 300, D-300
WASTE OIL HEATER**

**Installation and Operation
Instructions**



Lanair Products LLC
4109 Capital Circle
Janesville, Wisconsin 53546
1-888-370-6531
www.lanair.com



BEFORE YOU BEGIN INSTALLATION...

SAFETY, CODES, AND REGULATIONS

Thank you for the purchase of a Lanair used oil furnace. Lanair furnaces are designed and tested for safe, reliable long term operation. However, proper installation, fuel quality control, and regular maintenance are required. Please read and understand this manual completely before attempting to install, operate, or service the furnace. Keep this instruction manual and maintain it in legible condition. If you have any questions, please go to www.lanair.com or call 1-888-370-6531 for Lanair Technical Service.

CONVENTIONS USED IN THIS MANUAL

For your safety, this manual uses the following definitions and signal words to identify hazards:

⚠ DANGER **Danger:** Indicates an imminently hazardous situation which, if not avoided, will result in death or serious injury. This signal word is limited to the most extreme situations.

⚠ WARNING **Warning:** Indicates a potentially hazardous situation which, if not avoided, could result in death or serious injury.

⚠ CAUTION **Caution:** Indicates a potentially hazardous situation which, if not avoided, may result in minor or moderate injury. It may also be used to alert against unsafe practices.

CAUTION **Caution (without alert symbol):** Indicates an unsafe practice which, if not avoided, may result in product or property damage. Also used for general alerts.

PRODUCT SAFETY LABELS AND THEIR MEANING:

(NOT ALL LABELS USED ON ALL PRODUCTS)



Electrical Shock / Electrocutation



Hand Crush / Force From Side



Flammable Material



Explosion



Burn Hazard / Hot Surface



Explosion / Release of Pressure

Visit our website at: www.lanair.com



BEFORE YOU BEGIN INSTALLATION...

IMPORTANT

Read and understand this manual completely before beginning installation.

▲ WARNING

- This heater is for commercial and industrial use only. **This unit is not intended for residential use.**
 - This heater must be installed and/or inspected by a licensed heating contractor before operation. Installer should be trained and thoroughly familiar with the installation and operation of oil-fired heaters.
 - Installation of this unit must be made in accordance with state and local codes or authorities having jurisdiction over environmental control, fuel, fire and electrical safety.
 - N.F.P.A. (National Fire Protection Association Publications for Heater Installation)
 - NFPA No. 30 Flammable and Combustible Liquids Code
 - NFPA No. 31 Standard for the Installation of Oil Burning Equipment
 - NFPA No. 70 National Electric Code
 - NFPA No. 80 A&B Repair Garages and Parking Structures
 - NFPA No. 211 Standard for Chimneys, Fireplaces, Vents, and Solid Fuel Burning Appliances
- The above standards are available from the National Fire Protection Assn., Battery March Park, Quincey, MA 02269; <https://www.nfpa.org/>
- Read and familiarize yourself with these instructions and associated photos, diagrams and illustrations before beginning installation or operation. These instructions should be followed closely, to achieve the best possible results.
 - If you have questions or concerns at any time during the installation, stop the installation and contact a Lanair Service Representative.
 - Check to make sure you have all the required components needed for proper installation and operation.
 - Check each component for visible damage. If you find a damaged component, contact a Lanair Service Representative for a replacement. Do not install broken or damaged parts.
 - This heater is designed to provide economically and environmentally friendly disposal of waste oil. Due to the nature of the fuel used, this heater should not be relied upon as the sole source of heat.
 - Read and understand the warranty. Fill out the enclosed warranty card and return within 10 days of purchase.

QUESTIONS?... Contact Customer Service at 1-888-370-6531 M-F 8:00 am- 4:15 pm CST

XT SERIES WASTE OIL HEATER

Installation and Operating Instructions

Table of Contents:

	Safety, Codes, and Regulations	page i
	Important Instructions	page ii
Sec. 1	General Specifications & Safety.....	page 1
Sec. 2	Systems & Controls.....	page 10
Sec. 3	Heater Installation.....	page 15
Sec. 4	Chimney /Vent System.....	page 18
Sec. 5	Fuel Supply Tank /Piping Installation.....	page 23
Sec. 6	Fuel Supply Pump/Piping.....	page 27
Sec. 7	Compressed Air Installation	page 29
Sec. 8	Electrical Connections/Wiring Diagram.....	page 30
Sec. 9	Priming Fuel Pump.....	page 35
Sec.10	Burner Start-Up Procedure	page 36
Sec.11	Flame Adjustment	page 38
Sec.12	Maintenance Schedule / Service Adjustments.....	page 41
Sec.13	Troubleshooting	page 49
	Warranty and Return Process	page 54
	Warranty Certificate	page 55

Section 1 - General Specifications & Safety

DIMENSIONS (CABINET):

XT-150 & 200	Height: 24.25"	Width: 40.5"	Depth: 48"	Weight: 453 LBS
XT-250 & 300	Height: 36"	Width: 45.75"	Depth: 47"	Weight: 670 LBS
XTD-200	Height: 24.25"	Width: 40.5"	Depth: 56"	Weight: 485 LBS
XTD-300	Height: 36"	Width: 45.75"	Depth: 54"	Weight: 658 LBS

FIRING CAPACITIES:

XT-150	1.1 gallons/hour	XT-200 (XTD-200)	1.4 gallons/hour
XT-250	1.8 gallons/hour	XT-300 (XTD-300)	2.1 gallons/hour

MINIMUM CLEARANCE TO COMBUSTIBLES:

Top.....	6"	Chimney Connector.....	18"
Sides.....	18"	Rear	6" (allow 18" for service)
Burner Side.....	38"		
Front.....	60"	Bottom.....	24"

THIS HEATER IS DESIGNED TO BURN THE FOLLOWING APPROVED FUELS:

Used 5W to 50W Crankcase Oils (including synthetics), used ATF, and No.2 Fuel Oils

- The Lanair Heater provides the owner with a dependable, versatile, and simple means of burning No.2 fuel oil, used crankcase oils (5W through 50W), and used ATF. Maintained correctly, the heater will give you years of service. Please carefully read this owner's manual. If in any case you have a problem with your heater, or its installation, you should contact the Lanair Customer Service Department at 1-888-370-6531.
- **Only select models are designed for attachment or use with ductwork. Please confirm that you have purchased the correct model for your application.**
- **Do not attempt to start the burner when excess oil, oil vapor, or fumes have accumulated! Never press the red button on the oil primary control more than twice! This could cause excess vapor, or fuel to ignite causing damage to the heater and/or chimney.**
- Do not store or use gasoline, or any other flammable liquid and/or vapors near this heater.
- Fuel storage must be located a minimum of 5 feet from the heater.
- This heater is not designed for use in hazardous atmospheres such as: Paint Shops, Feed-mills, or installations where explosive or flammable conditions are present or could occur.

⚠ CAUTION



WARNING! Lanair heaters rely on natural draft. Downdrafts (reverse flow) in the heater's chimney will occur in buildings where negative pressures are created by exhaust fans, (car exhaust, paint booths, etc.). A power vent may not be sufficient to overcome a downdraft. An adequate make-up air system is required when exhaust fans are used (consult your heating contractor).

Visit our website at: www.lanair.com



Section 1 - General Specifications & Safety

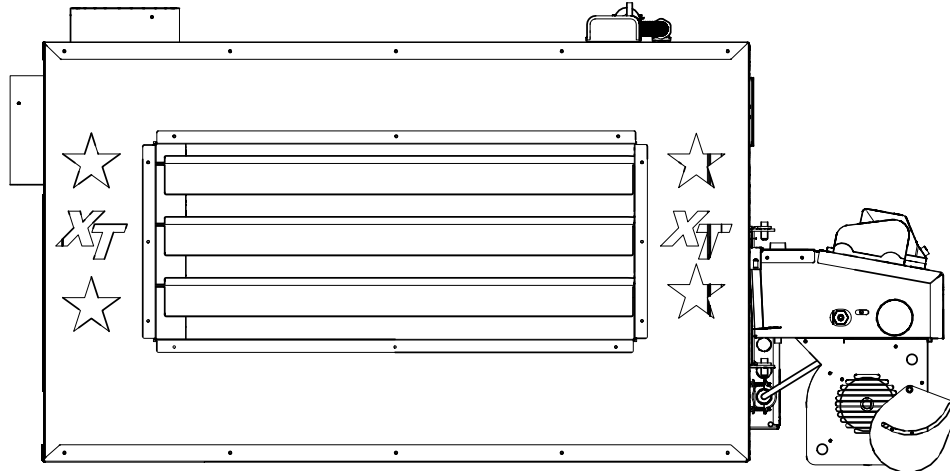

XT-150 FRONT

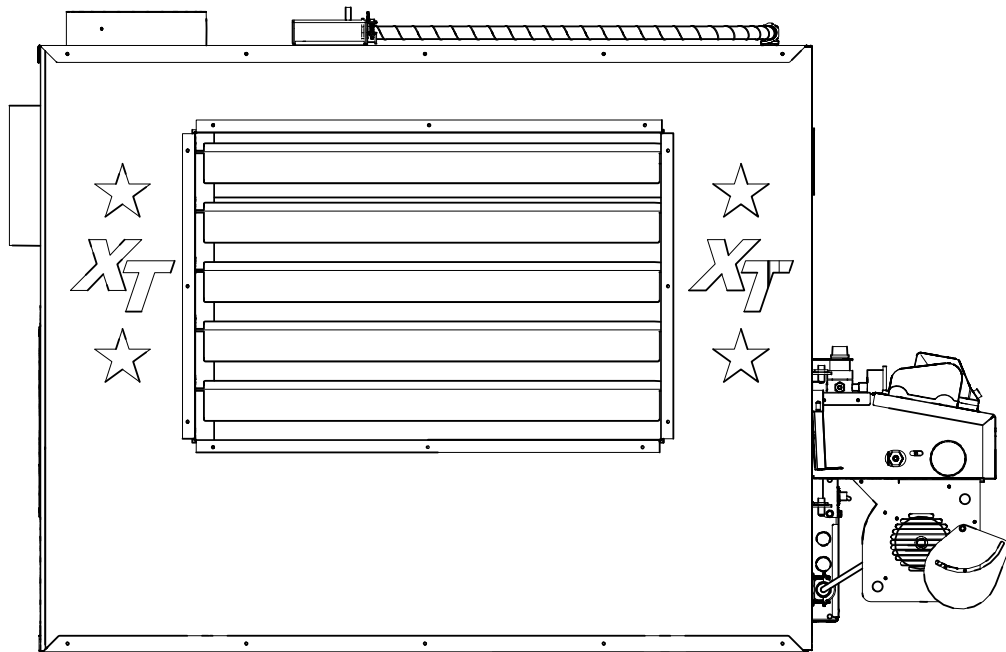

XT-250 FRONT

QUESTIONS?... Contact Customer Service at 1-888-370-6531 M-F 8:00 am- 4:15 pm CST

Section 1 - General Specifications & Safety

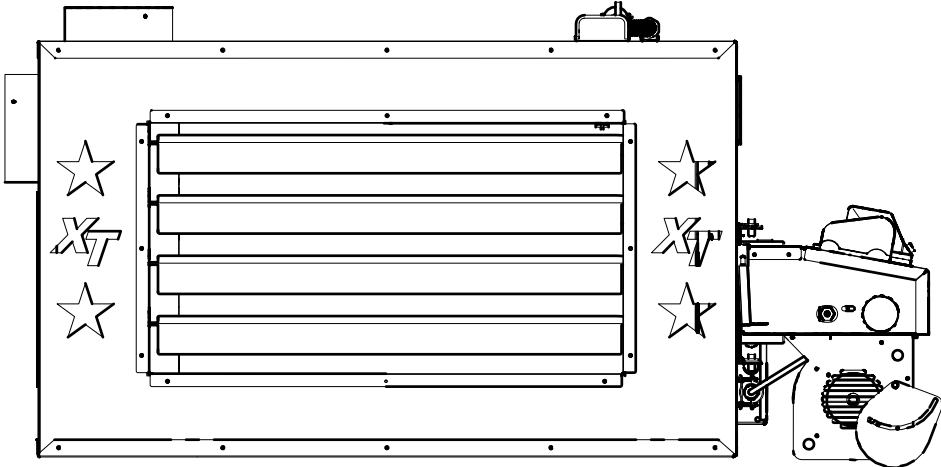

XT-200 FRONT

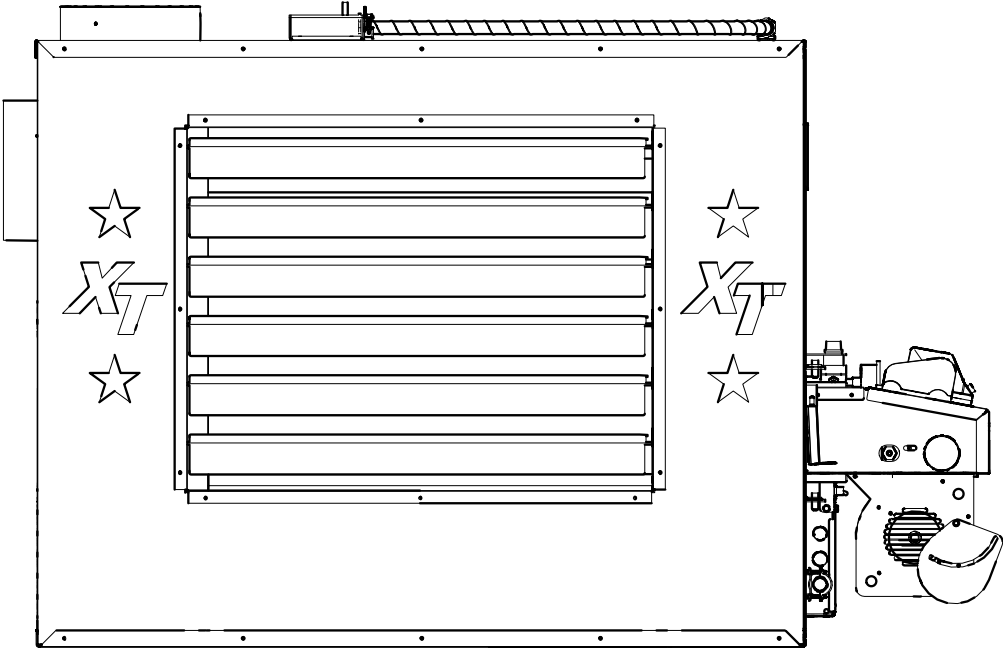

XT-300 FRONT



Section 1 - General Specifications & Safety

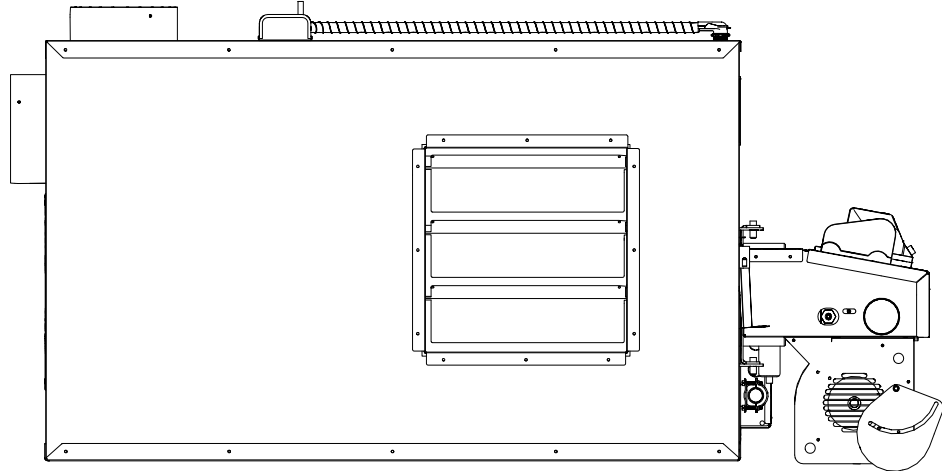

XTD-200 FRONT

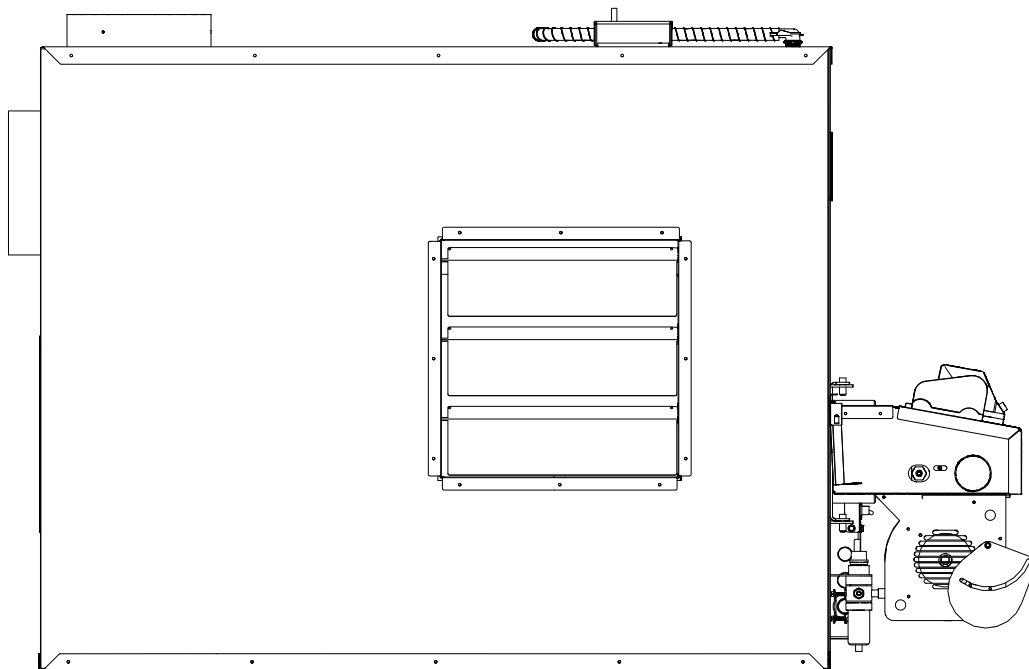

XTD-300 FRONT

QUESTIONS?... Contact Customer Service at 1-888-370-6531 M-F 8:00 am- 4:15 pm CST

Section 1 - General Specifications & Safety

XT-150/200

Top View

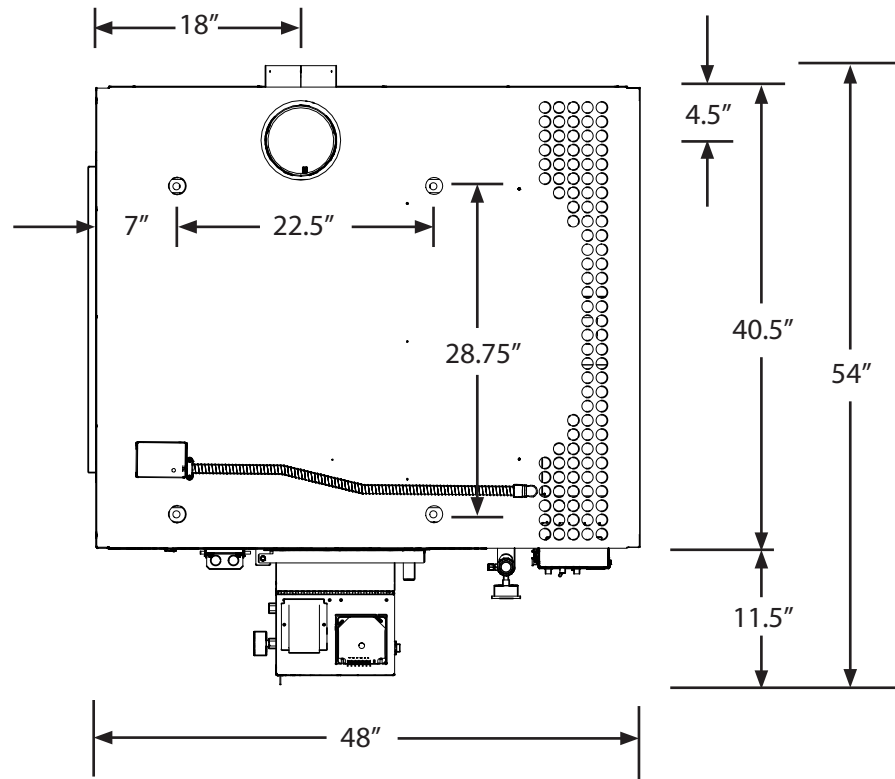

Right Side

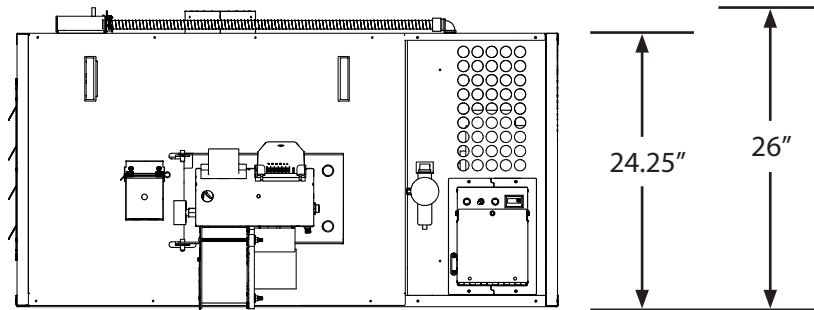

Left Side

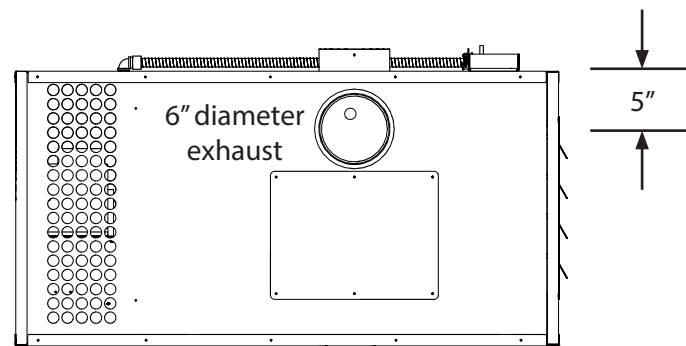



Section 1 - General Specifications & Safety

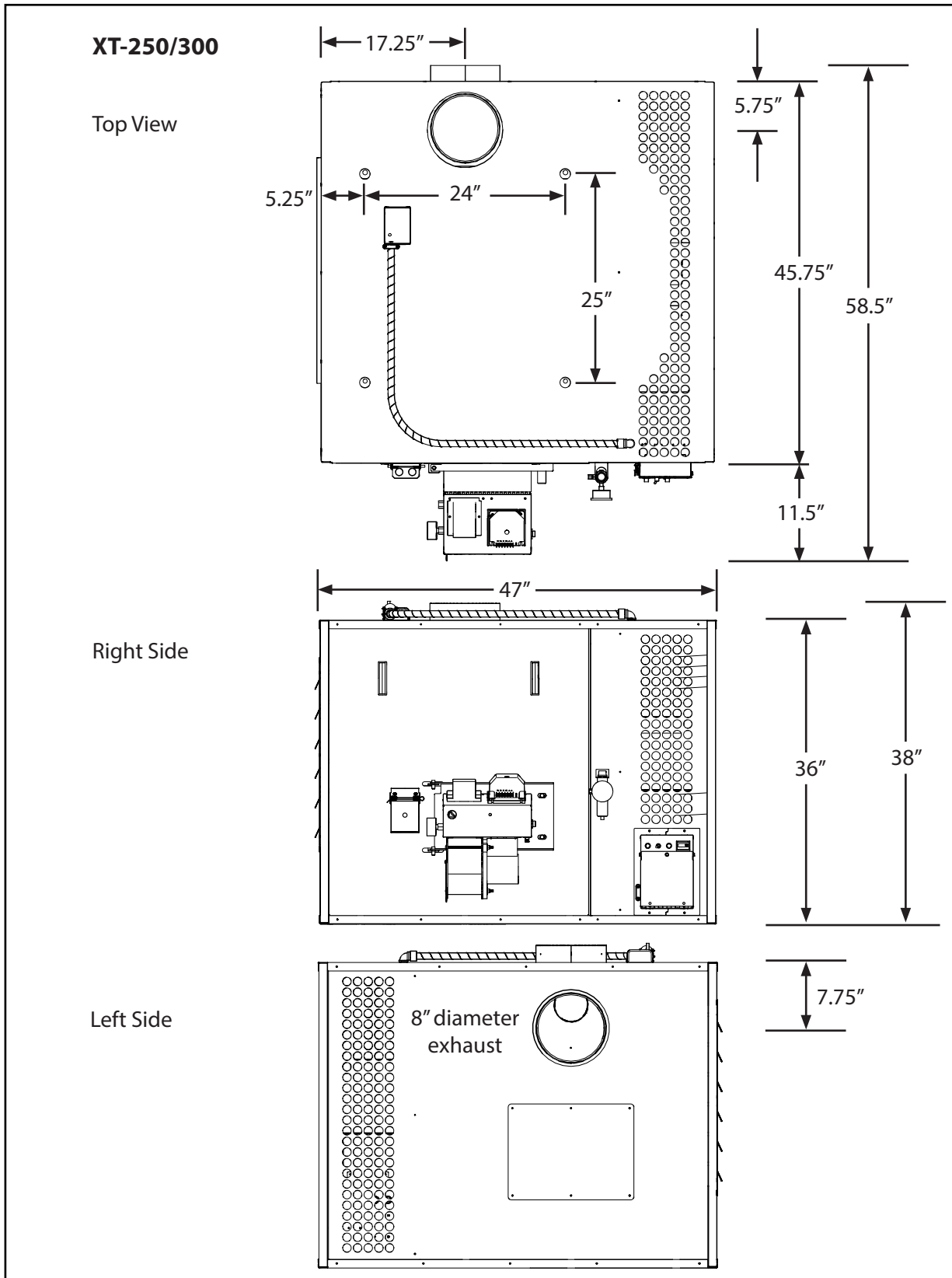

QUESTIONS?... Contact Customer Service at 1-888-370-6531 M-F 8:00 am- 4:15 pm CST

Section 1 - General Specifications & Safety

XTD-200

Top View

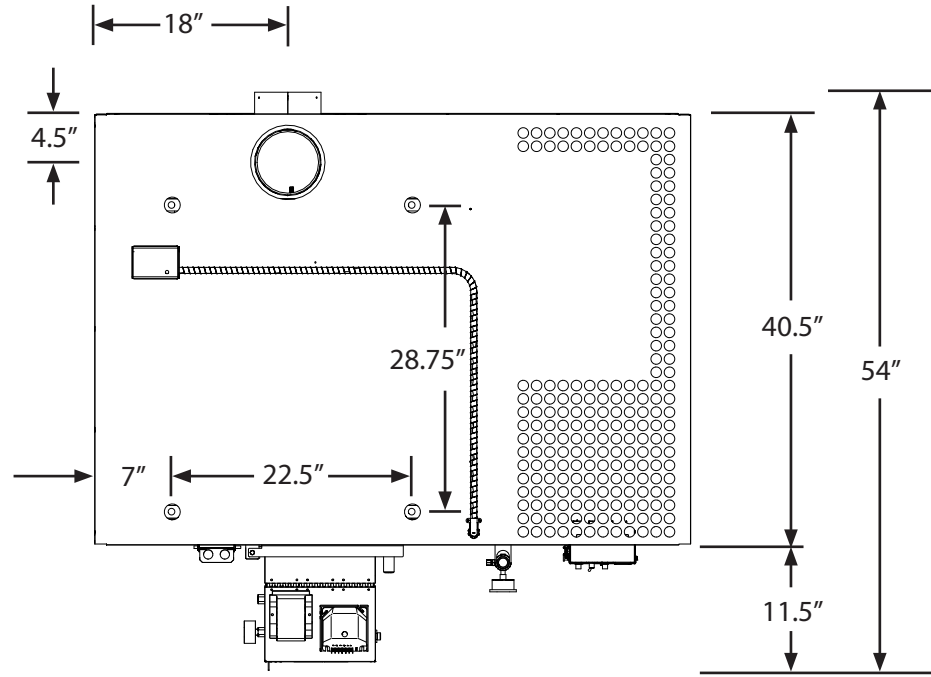

Right Side

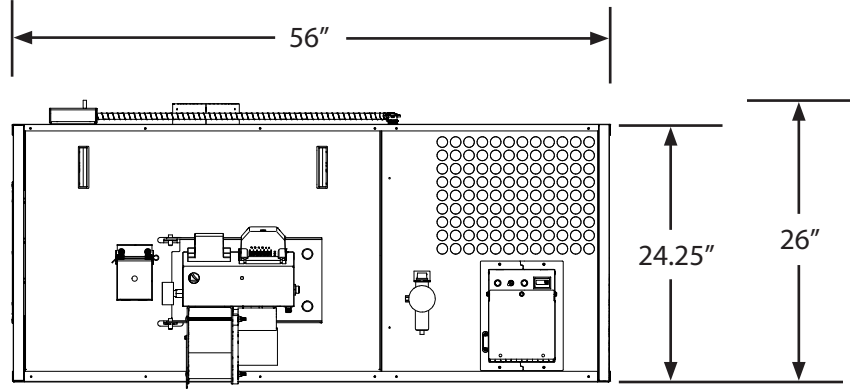

Left Side

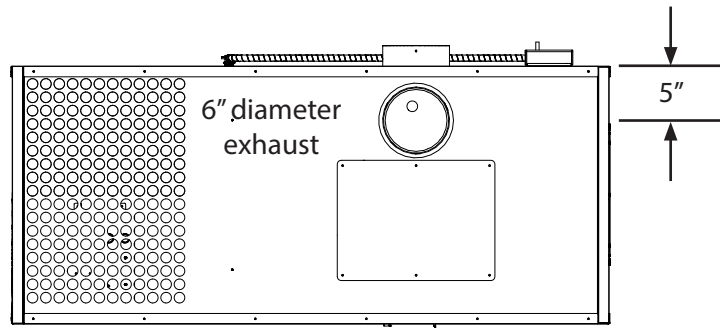



Section 1 - General Specifications & Safety

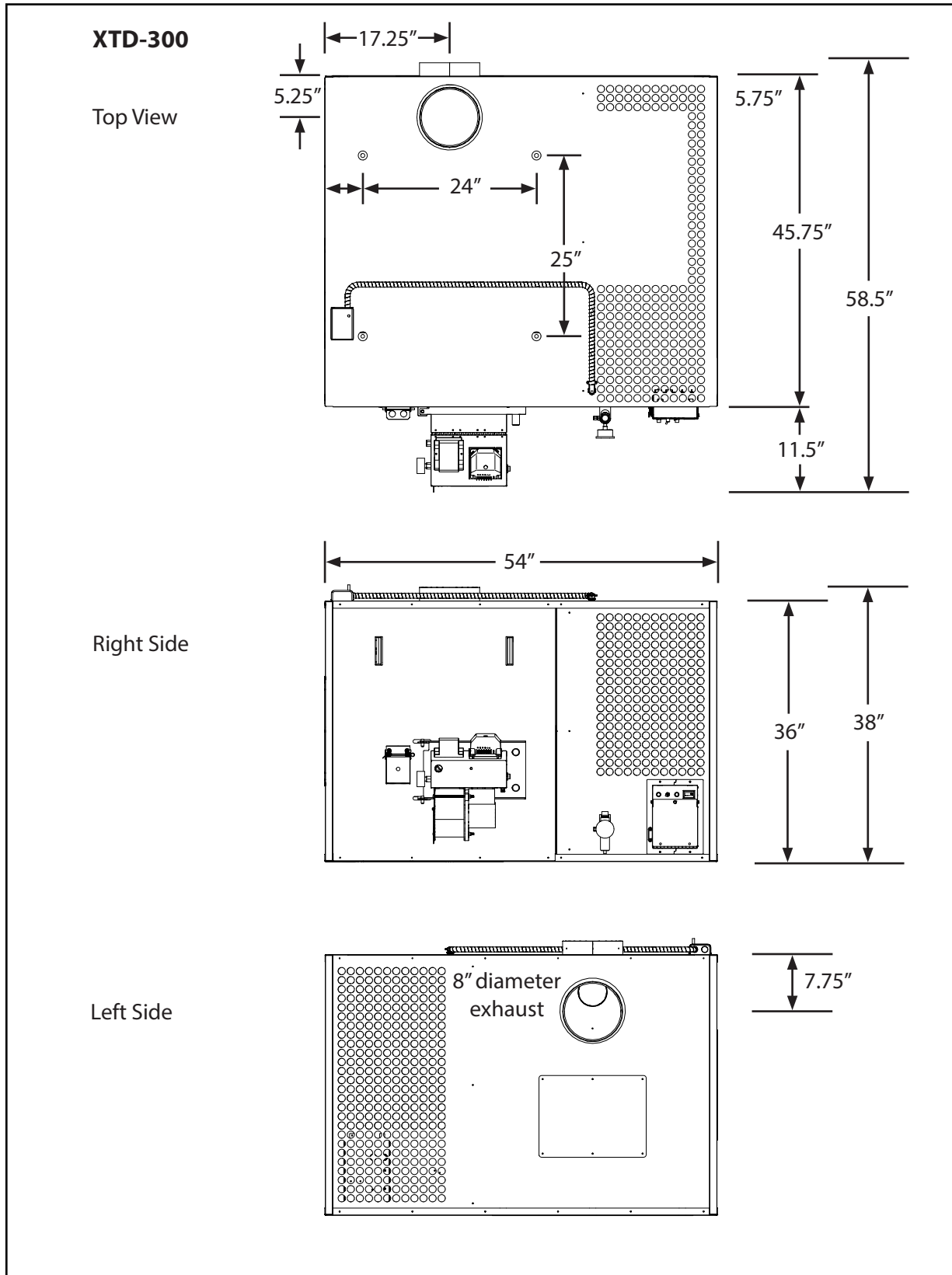

QUESTIONS?... Contact Customer Service at 1-888-370-6531 M-F 8:00 am- 4:15 pm CST

Section 1 - General Specifications & Safety

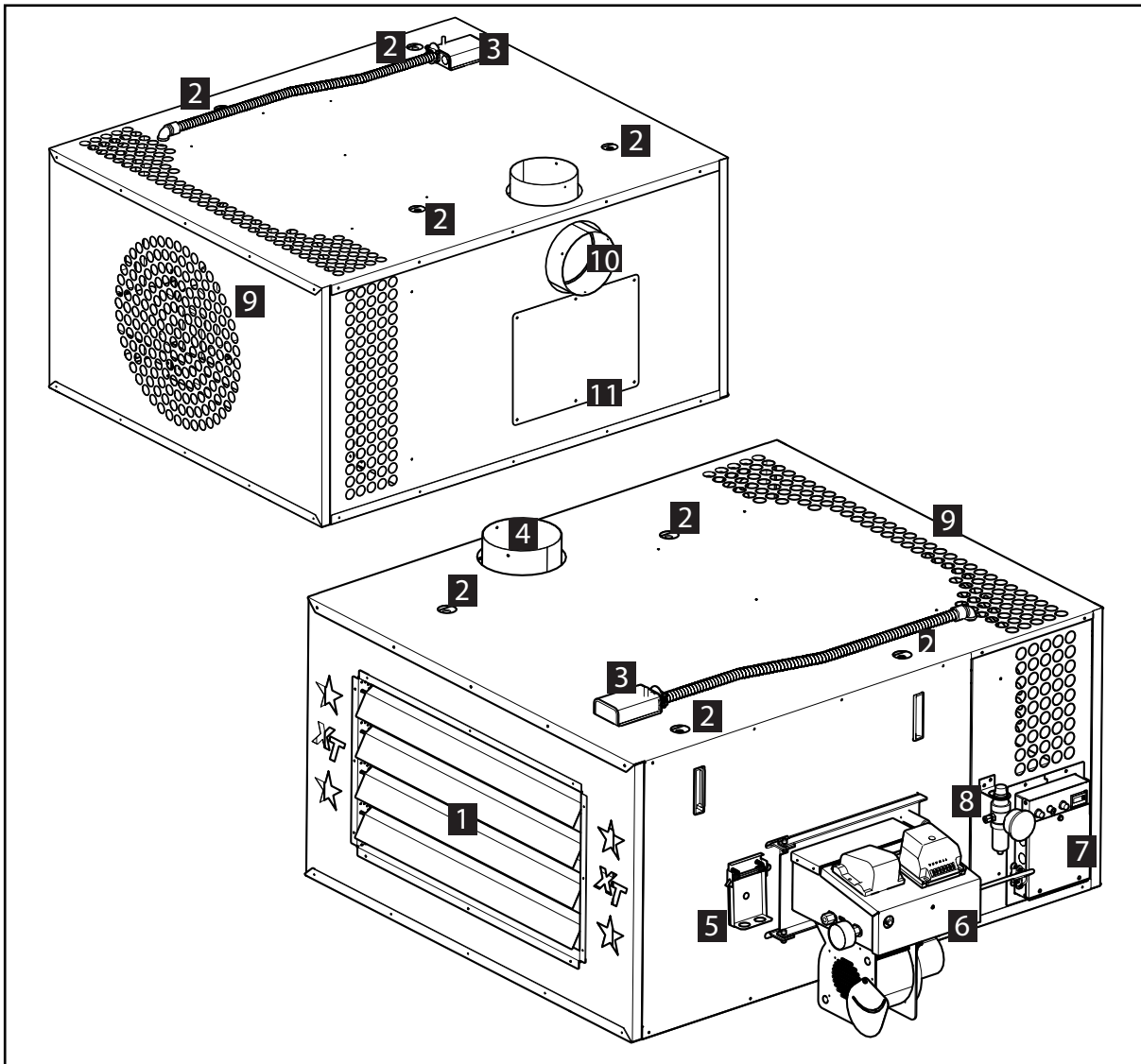

No.	Description
1	Adjustable Air Flow Louvers
2	Mounting Holes
3	Fan Limit Switch
4	Top Exhaust Port (Alternate)
5	Flame View Port
6	Burner Assembly
7	Electrical Connections Cover
8	Secondary Air Filter/Regulator Location
9	Fan Assembly
10	Side Exhaust Port (Primary)
11	Rear Ash Box Cover

Visit our website at: www.lanair.com



- **Room Thermostat:**

The room thermostat automatically controls the on/off operation of the heater according to the setting of the desired room temperature. The thermostat works in conjunction with the oil primary safety control.

- **Oil Primary Safety Control/Flame Sensor:**

The oil primary control is mounted on top of the burner's electrical box. When the thermostat calls for heat the oil primary control starts the burner by switching on the air solenoid valve, ignition transformer, combustion air blower, and the fuel pump. The oil primary control works in conjunction with the flame sensor (sometimes referred to as a cad cell). The flame sensor is mounted inside the burner cover, and faces the flame. The flame sensor monitors the light level inside the combustion chamber to ensure a flame is present. If there is a loss of flame the primary control will go into its recycle mode. After a period of time, the primary control will attempt to restart the burner. When this happens, if a flame is established, the burner will continue to function. If on start-up no flame is established in 30 seconds the primary control will lock out, requiring the reset button to be pressed manually.

⚠ CAUTION : Do not press the reset button more than twice. If the burner fails to function properly, refer to **Section 13 - Trouble Shooting**.

- **Fan/Limit Control**

The fan/limit control monitors the temperature of the air inside the cabinet. When the air reaches a set point (usually 120° F), it will switch on the heater fan. When the temperature in the cabinet drops below a set point (usually 90° F), the fan/limit control will turn the fan off. If the temperature exceeds a fixed set point, (usually 200° F), it switches the burner (Oil Primary Control) off until the temperature drops to a safe level. The burner will then restart.

⚠ CAUTION : If the heater shuts down due to "High Limit" temperature conditions, the cause must be determined and corrected before further use (over firing the unit is normally what causes this condition).

The fan/limit control also features an external switch to turn the axial fan on manually, bypassing its automatic function. The Fan/Limit Control is located on the top of the cabinet, towards the front of the unit.

- **Barometric Draft Control**

The Barometric Draft Control automatically maintains a preset chimney draft. It is located in the chimney connector or flue.

- **Air Filter/Regulator**

The Air Filter/Regulator performs two functions: It removes condensation and dirt from the air while controlling the amount of air pressure reaching the nozzle and air operated fuel valve. The Air/Filter Regulator is mounted on the cabinet near the burner.

- **Electric Air-Solenoid Valve**

The electric air-solenoid valve is controlled by the oil primary control. It acts as a shut-off valve, (it's open during operation, and closed when the burner is off). The electric air-solenoid valve is located inside the burner's electrical box.

- **Air Operated Fuel Valve**

The air-operated fuel valve controls fuel flow out of the nozzle. When the electric air-solenoid valve opens and air pressure pushes on the fuel valve diaphragm, the plunger moves off the nozzle seat allowing fuel to enter the nozzle. The air-operated fuel valve is located on the back of the air preheater.

- **Air/Oil Preheater**

The air/oil preheater is an assembly that preheats the atomizing air and fuel to a predetermined temperature to properly combust used oil. The air/oil preheater is located in the burner.

- **Snap Disc**

The snap disc accurately controls the temperature of the air/oil preheater assembly with two resistance type cartridge-heating elements. The snap disc is mounted on the oil preheater inside the burner.

- **Nozzle**

The nozzle uses air pressure to help deliver fuel through its small orifice, and to atomize the fuel for proper combustion. The nozzle is located on the end of the air preheater opposite the fuel valve. Replace the nozzle annually, as they are prone to wear by contaminants in waste oil.

- **Fuel Bypass Regulator (This is not used with the Optional metering pump)**

The fuel bypass regulator controls the pressure of the fuel to the nozzle. The fuel bypass regulator is located in the line between the outlet side of the pump and the burner.

- **Fuel Supply Pump**

The fuel-supply pump delivers fuel from your oil storage tank to the burner. The fuel supply pump should be located as close to the fuel supply tank as possible. The fuel supply pump must be mounted with the motor shaft oriented horizontally.

- **Optional Metering Pump Assembly**

The metering pump delivers fuel from your oil storage tank to the burner. It also controls the volume of fuel, and no regulator is required. The metering pump should be mounted with the motor shaft oriented horizontally.

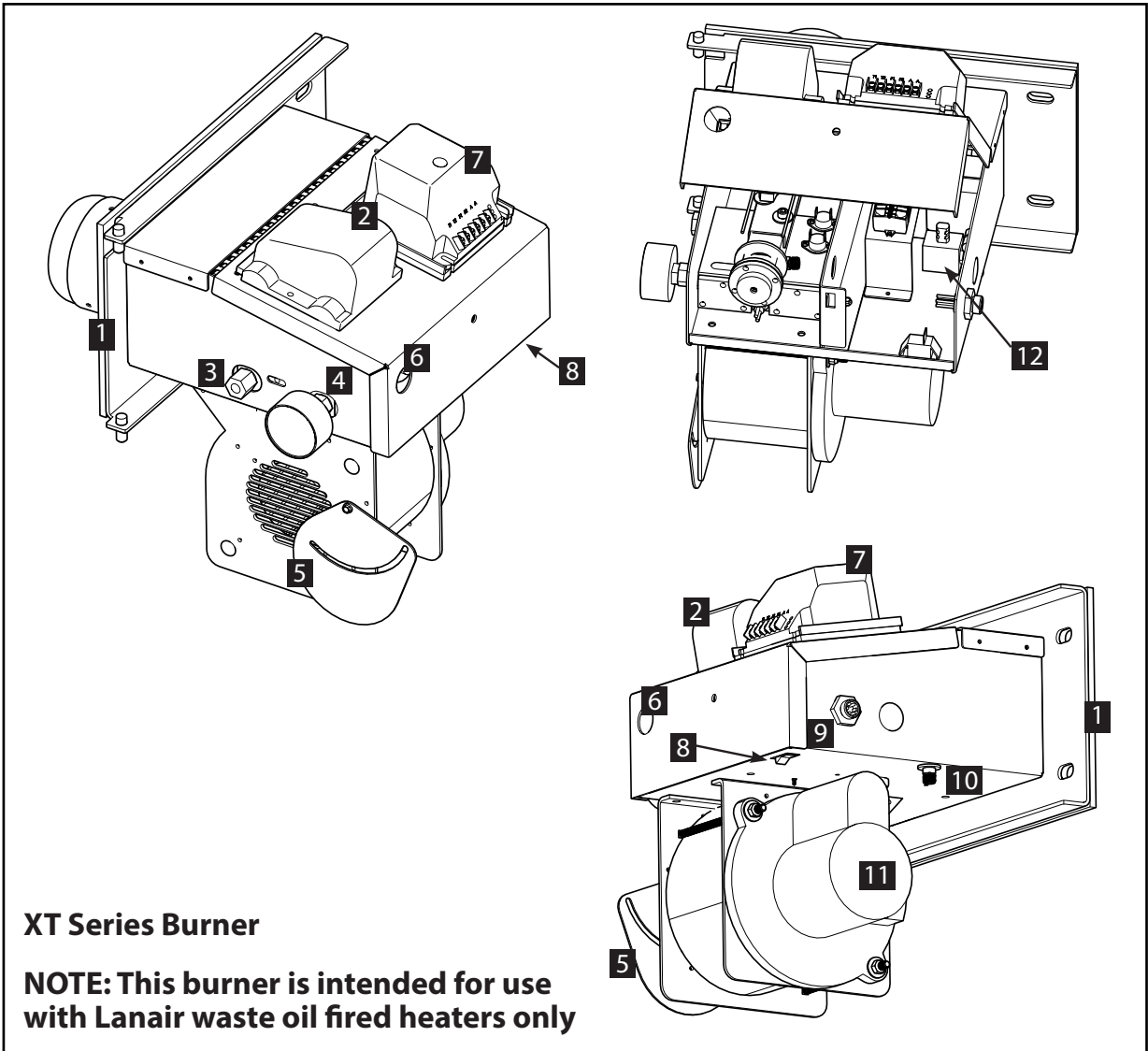

XT Series Burner

NOTE: This burner is intended for use with Lanair waste oil fired heaters only

No.	Description
1	Mounting Plate w/ Gasket
2	Ignition Transformer
3	Fuel Line Inlet
4	Fuel Pressure Gauge
5	Combustion Air Baffle
6	View Port
7	Oil Primary Safety Control
8	Waste Oil/Fuel Oil Switch
9	Quick Disconnect Receptacle
10	Air Supply Inlet
11	Combustion Blower Motor
12	Air Solenoid Valve

**Burner Assembly-
Performance Ratings**

Voltage	115 vac
Cycles	60 Hz
Total Operating Amperage	7.7
Weight	31 lbs
Oil Primary	0.2 amps
Pre-Heater Block	4.5 amps
Ignition Transformer	0.3 amps
Burner Motor	2.7 amps

QUESTIONS?... Contact Customer Service at 1-888-370-6531 M-F 8:00 am- 4:15 pm CST

Pump Assembly for use with Bypass Regulator

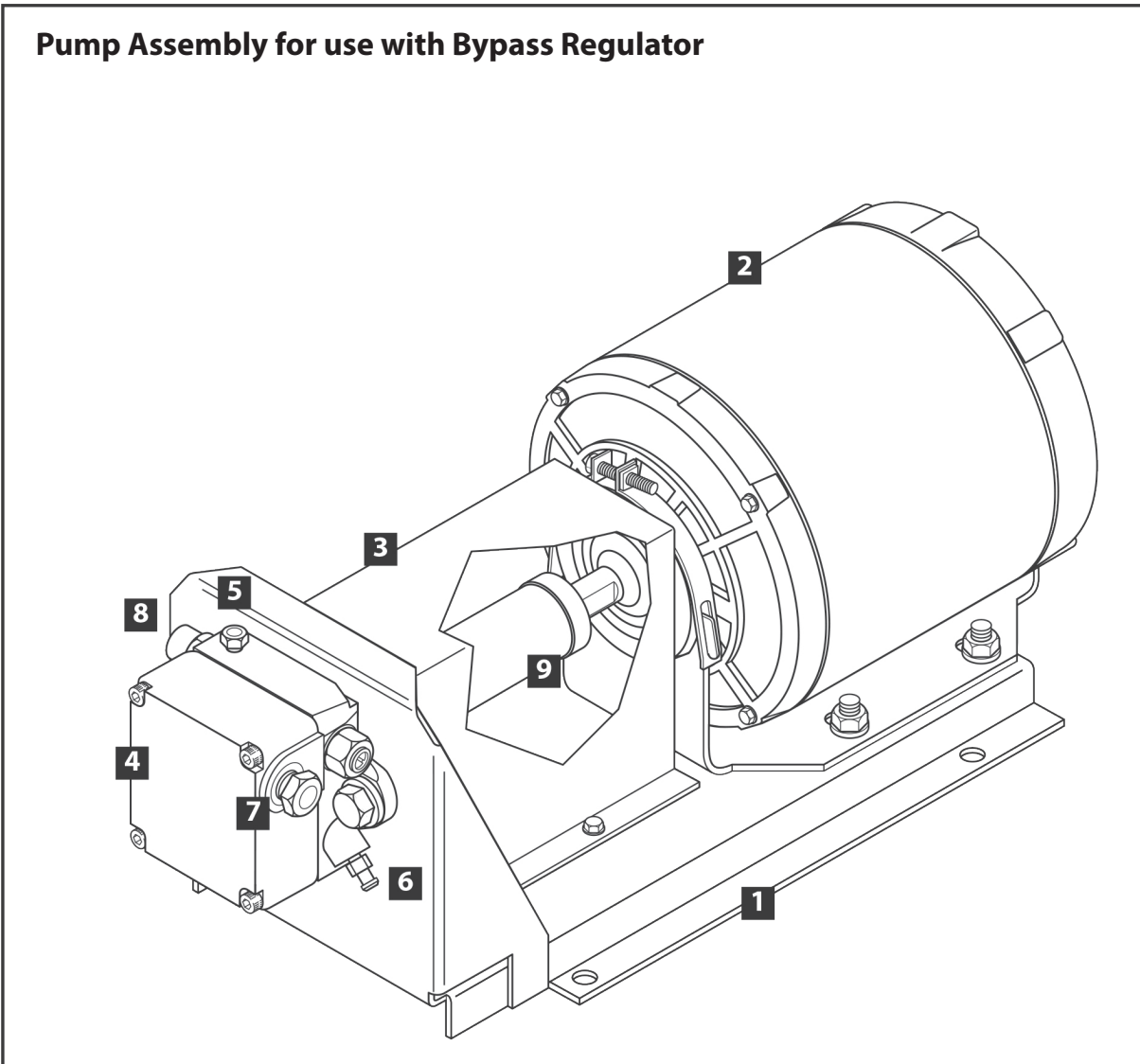

No.	Description
1	Pump Platform
2	Pump Motor
3	Pump Guard
4	Pump
5	Pressure Gauge port
6	Easy Flow Bleed Valve
7	1/4" NPT Inlet
8	1/8" NPT Outlet
9	Pump-Motor Coupling

Pump Assembly-

Performance Ratings

Voltage115 vac
 Cycles 60 Hz
 Weight 24 lbs
 Pump Motor 5 amps
 Max. Pumping Distance30 feet

Optional Metering Pump Assembly

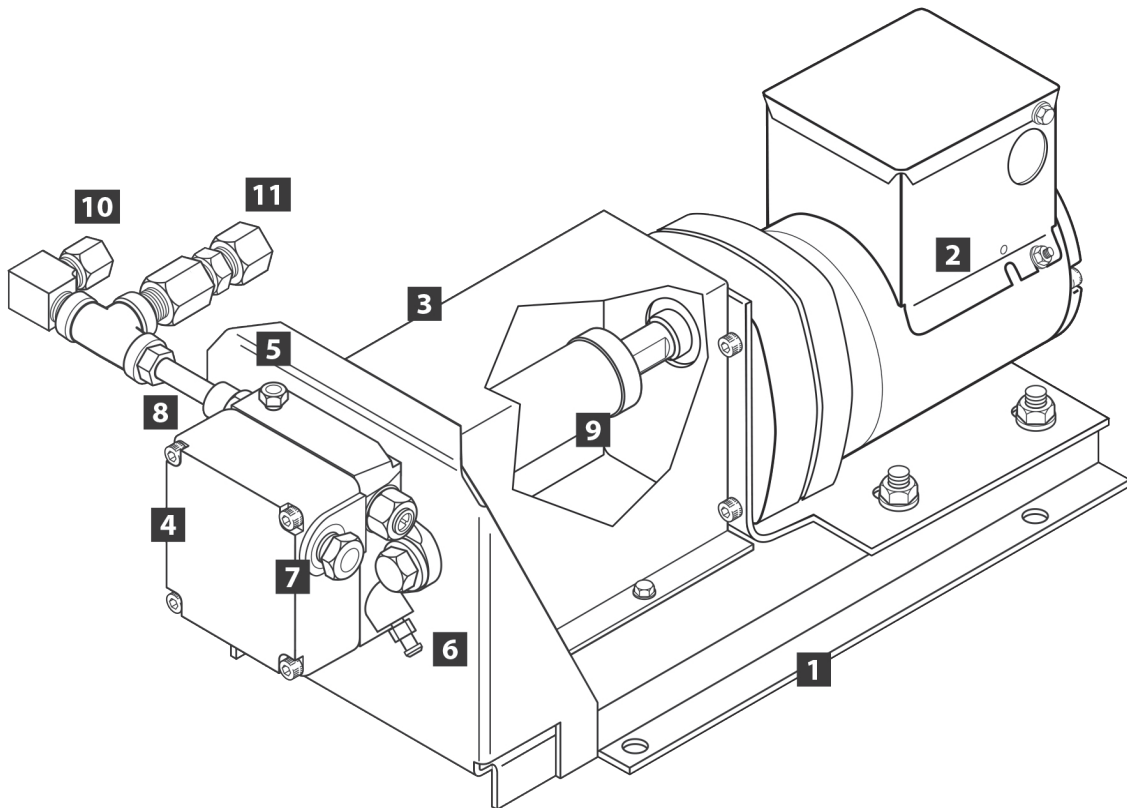

No.	Description
1	Pump Platform
2	Pump Motor
3	Pump Guard
4	Pump
5	Pressure Gauge port
6	Easy Flow Bleed Valve
7	1/4" NPT Inlet
8	1/8" NPT Outlet
9	Pump-Motor Coupling
10	Line to Burner
11	Pressure-Relief Valve Return to Tank

Pump Assembly-

Performance Ratings

Voltage	115 vac
Cycles	60 hz
Weight	16 lbs
Pump Motor	0.59 amps
Max. Pumping Distance	100 feet

Section 2 - Systems & Controls

Adjustable Locking Louvers

The XT Series heaters feature spring loaded locking louvers. To adjust:

- Slowly push the louver to the left until the locking pin disengages. **NOTE:** Do not allow the pivot pin to come out of the hole.
- Tilt the louver forward/backward until desired position is obtained.
- Release louver so locking pin seats into the hole.

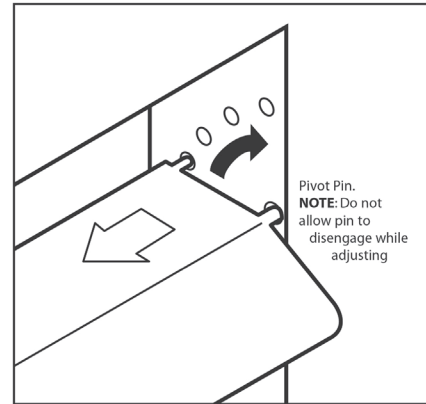

Ductable Applications

XTD units are designed for outlet-air ducting with 0.20" W.C. or less static pressure. Existing louvers must be removed before attaching ductwork. This unit is not designed for a return air connection. A qualified heating contractor must design the ductwork for your installation. Existing ductwork may not meet the requirements of this furnace.

Section 3 - Heater Installation

General Requirements

1. Do not install the heater on a combustible surface of any kind. For minimum clearance to combustible material (see Page 9).
2. Install the heater in a location to utilize total heat throw (blown hot air).
3. Install the heater in a location to permit a correct outdoor chimney exit to eliminate down drafts, and provide easy chimney installation and maintenance. Class A chimney **MUST** be used when passing through any wall or ceiling. See Section 4 Chimney Installation.
4. Install the heater in a location to permit the fuel supply to be as close as possible.
5. If the heater is not installed on a tank stand supplied by Lanair, a metering pump may be desired in order to eliminate the need to adjust oil flow from a distance.
6. Before suspending the heater check the supporting structure and reinforce if necessary to support the weight of the heater/system.
7. Use 3/8", 16 TPI, steel threaded rod and locking nuts to suspend the heater from a capable load carrying ceiling structure when not mounting to a Lanair Waste Oil Storage Tank.

▲ WARNING

8. The heater must be suspended level for proper operation. A heater that is not level could cause a hazardous situation in which personal injury or property damage may result.

Visit our website at: www.lanair.com

TYPICAL INSTALLATION: HEATER/CHIMNEY PACKAGE *Tank-Mount Through-the-Roof*

Chimney cap must be at least 3 ft. taller than any object within 10 ft.

Class "A" chimney must be used for roof penetration and any exterior chimney

Total chimney length must be at least 10 ft. for sufficient draft

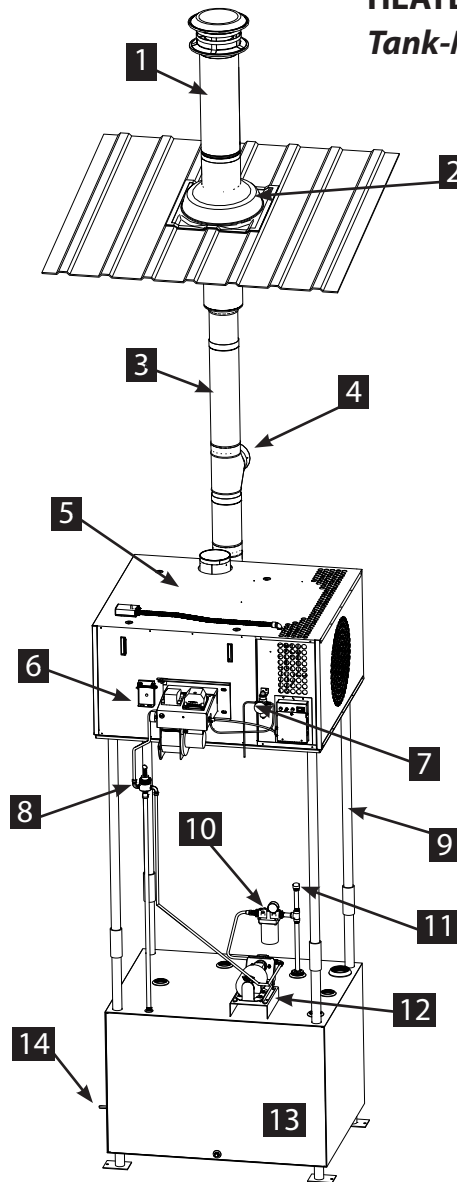

- | | |
|---------------------------------------|------------------------------------|
| 1. Double-Wall Chimney Flue (Class-A) | 10. Primary Strainer |
| 2. Roof Penetration | 11. Fill Pipe (for priming) |
| 3. Single-Wall Chimney Flue | 12. Fuel Pump |
| 4. Barometric Damper & Tee | 13. Fuel-Pickup Assembly (in tank) |
| 5. Tank-Mounted Heater Unit | 14. Tank Drain |
| 6. Burner | |
| 7. Secondary Air Regulator | |
| 8. Oil-Bypass Pressure Regulator | |
| 9. Tank-Mount Support Legs | |

Compressed-air supply, electrical shutoff switch, tank vent, and additional chimney material not included. Installation configurations vary. Additional materials will be necessary.

Contact Lanair for Assistance with special circumstances.

QUESTIONS?... Contact Customer Service at 1-888-370-6531 M-F 8:00 am- 4:15 pm CST

Section 3 - Heater Installation

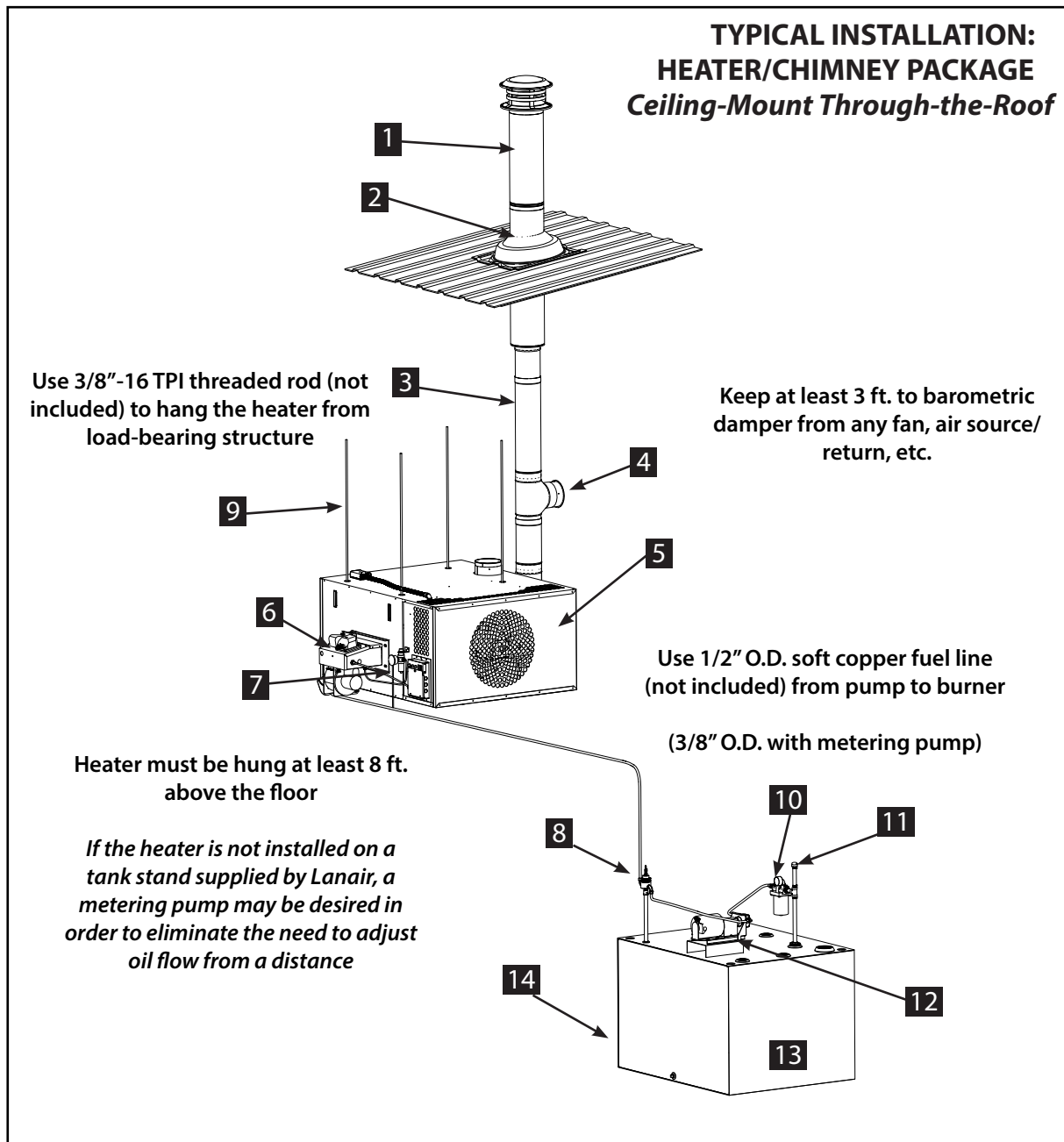

1. Double-Wall Chimney Flue (Class-A)
2. Roof Penetration
3. Single-Wall Chimney Flue
4. Barometric Damper & Tee
5. Ceiling-Mounted Heater Unit
6. Burner
7. Secondary Air Regulator
8. Oil-Bypass Pressure Regulator
9. Ceiling-Mount Support Rods (not included)

10. Primary Strainer
11. Fill Pipe (for priming)
12. Fuel Pump
13. Fuel-Pickup Assembly (in tank)
14. Tank Drain

Compressed-air supply, electrical shutoff switch, tank vent, and additional chimney material not included. Installation configurations vary. Additional materials will be necessary.

Contact Lanair for Assistance with special circumstances.

Visit our website at: www.lanair.com

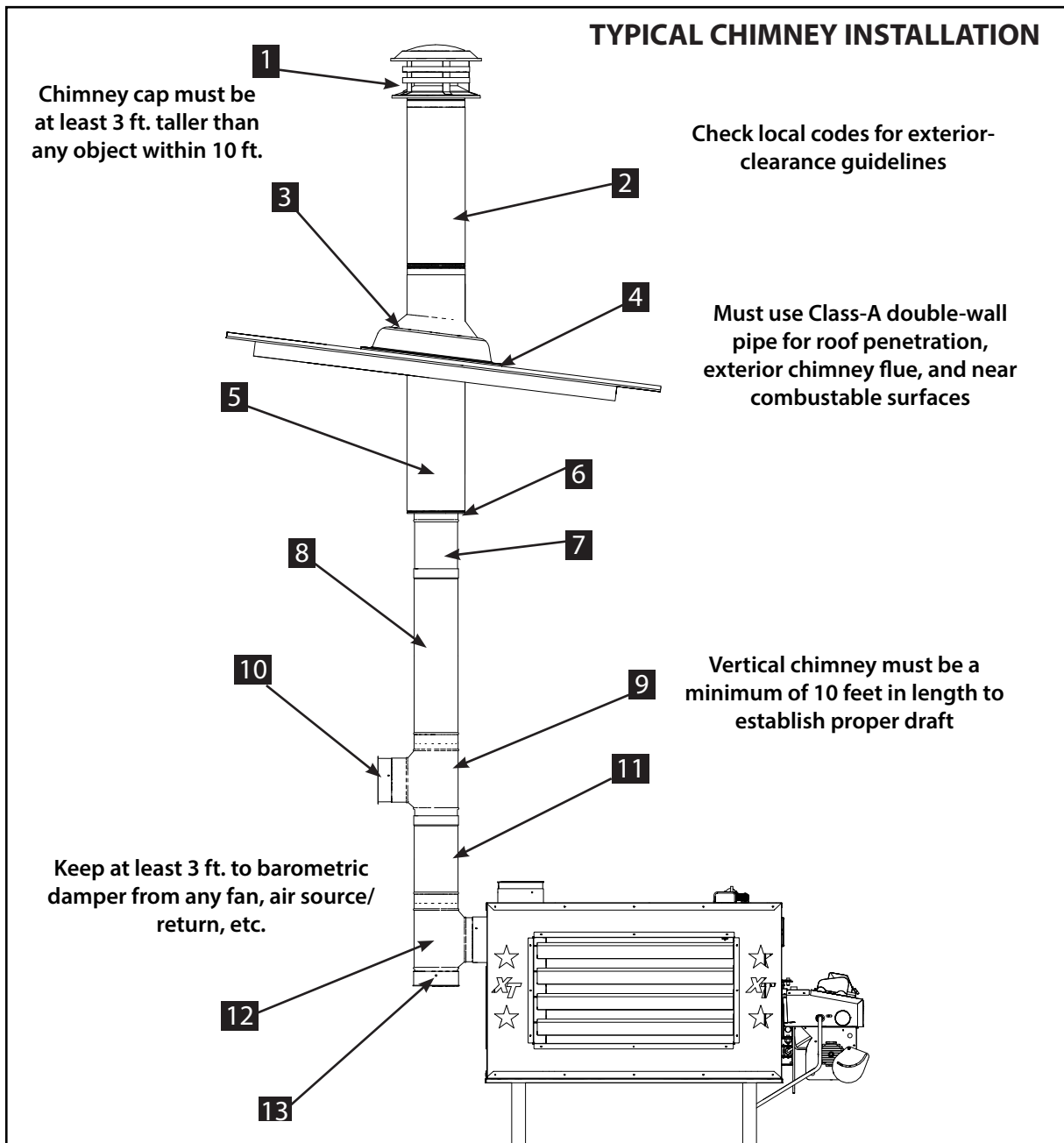

- | | |
|--------------------------------------|------------------------------------|
| 1. Chimney Cap | 10. Barometric Damper |
| 2. Double-Wall Chimney Pipe (36") | 11. Black (Single-Wall) Pipe (12") |
| 3. Rubber Boot/Storm Collar Flashing | 12. Black (Single-Wall) Tee |
| 4. Roof-Support Bracket | 13. Cleanout Cap |
| 5. Double-Wall Chimney Pipe (36") | |
| 6. Finishing Collar | |
| 7. Slip Connector (14") | |
| 8. Black (Single-Wall) Pipe (24") | |
| 9. Black (Single-Wall) Tee | |

Minimize or eliminate horizontal runs and angle/elbow connections, where possible. Consider chimney cleanout access when installing. If your installation fails to achieve proper draft, consider lengthening the vertical chimney.

Contact Lanair for Assistance with special circumstances.

QUESTIONS?... Contact Customer Service at 1-888-370-6531 M-F 8:00 am- 4:15 pm CST

Section 4 - Chimney/Vent System

⚠ DANGER



Failure to provide proper venting of the heater exhaust gases could result in death, serious injury, and/or property damage. FOLLOW CHIMNEY MANUFACTURERS INSTRUCTIONS.

General Requirements

⚠ DANGER

1. Safe operation of any gravity vented heating appliance requires a proper air make-up system to prevent the heater exhaust gases from being drawn into the building. These gases could cause death, serious injury, and/or property damage. Exhaust fans and paint booths may cause draft problems.

⚠ WARNING

2. Never vent this heater into another heating appliance's chimney. Never vent into 'Class B' chimney. Gas heaters use "Class B" chimney. It is rated for a much lower temperature than is required for your waste-oil furnace. This heater must have its own separate "Class A" chimney.

3. Inspect and maintain the chimney on an annual basis.

CAUTION

4. A U.L. listed barometric damper **MUST** be installed in the chimney or the **WARRANTY WILL BE VOID**. Do not reduce or enlarge the vent pipe.
5. Minimize or eliminate horizontal runs and angle/elbow connections, where possible. Consider chimney clean-out access when installing. If your installation fails to achieve proper draft, consider lengthening the vertical chimney.

Contact Lanair for Assistance with special installation circumstances.

6. To prevent the drawing of exhaust gases into the building, keep the barometric draft control at least 2 to 3 feet from any fan, blower, etc..
7. The position of the draft control Barometric Damper gate hinge pins must be horizontal (parallel to the floor) for proper operation.
8. Secure all connections in the chimney connector with 3 screws per joint.

⚠ WARNING

9. Clearance for the chimney connector and any single-wall flue to any combustible material is 18". The "Class A" chimney clearance to any combustible is 2". Follow the chimney manufacturer's instructions.

Barometric Damper Position

HORIZONTAL



VERTICAL

NOTE: Barometric Damper may be mounted horizontally or vertically. Angle gate pins must be horizontal for proper operation



Section 4 - Chimney/Vent System

General Requirements (cont.)

10. Do not install heat re-claimers, manual draft controls, or any other type of restrictive control(s) in the chimney.
11. Install clean out tee with a cap, at the transition of the chimney. **FOLLOW CHIMNEY MANUFACTURERS INSTRUCTIONS.**
12. Use "Class A" insulated chimney pipe to vent exhaust gases through wall, ceilings, attics, roofs, combustibles, etc. Class A chimney must be used for the entire run once passing through a wall or ceiling.
13. Vent chimney at least 3 feet above the roof and at least 3 feet higher than any portion of the building, roof, or obstruction within 10 feet of the chimney.
14. The chimney cap should be at least 3' above the chimney exit through the roof.
15. Do not use a rotating-turbine chimney cap. In areas of high wind, a swivelling wind-guard cap may be appropriate. Use a non-restrictive "Class A" cap made for the type "Class A" chimney you are using. Follow chimney manufacturer's instruction.
16. The chimney must be capable of producing a negative -0.02 W.C. draft when cold and -0.05 W.C. draft when hot
17. If you are unable to attain the proper draft, check for exhaust fans in the building. To test if there is a problem, open an overhead door and see if you now have the proper draft. You may have to add one or more sections of "Class A"chimney to the roof to get the proper draft.

⚠ CAUTION

18. **The heater and chimney must be installed in accordance with all state and local codes. The heater must be installed in accordance with the specifications listed in this manual. The chimney must be installed per the chimney manufacturer's instruction.**

NOTE: Do not install chimney in front of the heater (in air stream of fan)

Chimney Draft Requirements

CAUTION

The Lanair heater should have a (negative) -0.02 draft reading when cold, and a (negative) -0.05 when hot. Check the heater after it has been running for 45 minutes. If the reading is not what it should be, adjust the barometric damper to achieve proper draft. The draft reading should be measured with the manometer included with the heater, or a comparable alternative. Consult your heating contractor when needed.

QUESTIONS?... Contact Customer Service at 1-888-370-6531 M-F 8:00 am- 4:15 pm CST

Section 4 - Chimney/Vent System

Alternate Chimney Configurations

Some installation configurations may require orienting the chimney flue through the exterior wall, rather than the roof, or utilizing the top exhaust port of the heater, rather than the side port. Please consult with Lanair for guidance in these cases.

It is always preferable to install the chimney flue through the roof in order to ensure proper draft and minimize horizontal connectors that can collect debris and moisture. If installing the chimney through an exterior wall, be sure to adhere to height, clearance, and material requirements.

In most structures, using the side exhaust port of the heater makes it easier to install the heater and maintain height and clearance requirements. If utilizing the top exhaust port, be sure to adhere to height, clearance, and material requirements. If using the top port, the installed cap must be removed and placed on the side port using the screws provided.

Vertical chimney must be a minimum of 10 feet in length to establish proper draft

Horizontal chimney-connector length should be minimized (Max. 10 feet) and maintain 1/4" rise per 1 foot of run

Keep at least 3 ft. to barometric damper from any fan, air source/return, etc.

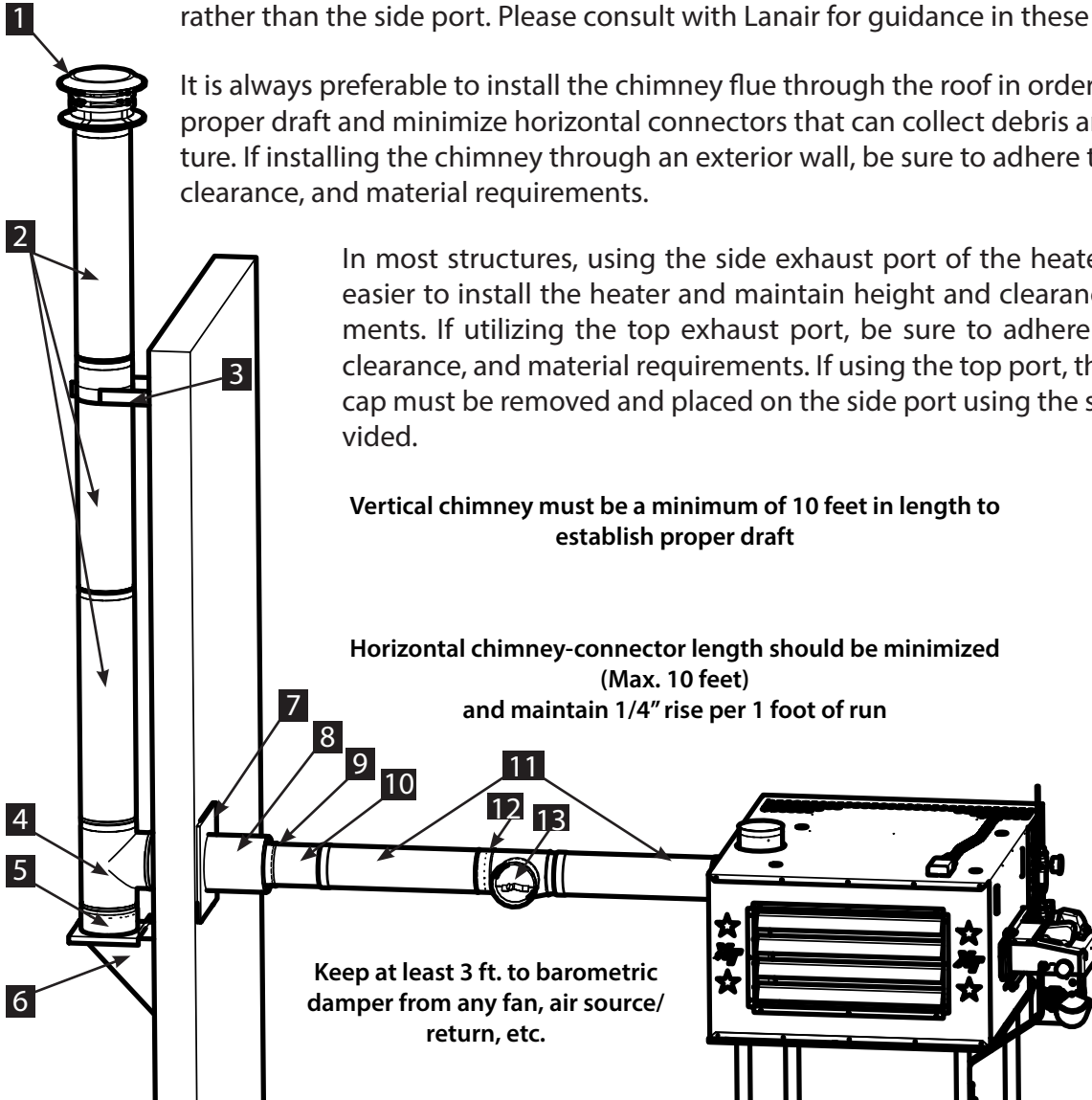

Through-Wall Chimney Installation

1. Chimney Cap
2. Double-Wall Chimney Pipe (36")
3. Wall Strap
4. Double-Wall Tee
5. Chimney Pie (6") & Cap
6. Tee Support Bracket
7. Slip Connector (14")
8. Double-Wall Chimney Pipe (18")
9. Finishing Collar
10. Slip Connector (14")
11. Black (Single-Wall) Pipe (24")
12. Black (Single-Wall) Tee
13. Barometric Damper

Minimize or eliminate horizontal runs and angle/elbow connections, where possible. Consider chimney cleanout access when installing. If your installation fails to achieve proper draft, consider lengthening the vertical portion of the chimney flue.

Contact Lanair for Assistance with special circumstances.

Visit our website at: www.lanair.com



Barometric Damper

The barometric damper balances the draft through the combustion chamber and allows for adjustments. It can be installed in various chimney orientations, but ensure that the barometric damper is installed with the pivot hinge parallel to the ground with the attached weight closing the door when no draft is present.

Adjusting the weight clockwise (bringing the weight closer to the damper door) will allow the door to open more when a draft is present, increasing the draft through the damper and decreasing the draft through the combustion chamber (lowering the manometer reading).

Adjusting the weight counter-clockwise (taking the weight farther from the damper door) will cause the door to open less when a draft is present, decreasing the draft through the damper and increasing the draft through the combustion chamber (raising the manometer reading).

NOTE: Keep the damper free of dust and debris and check for proper draft daily

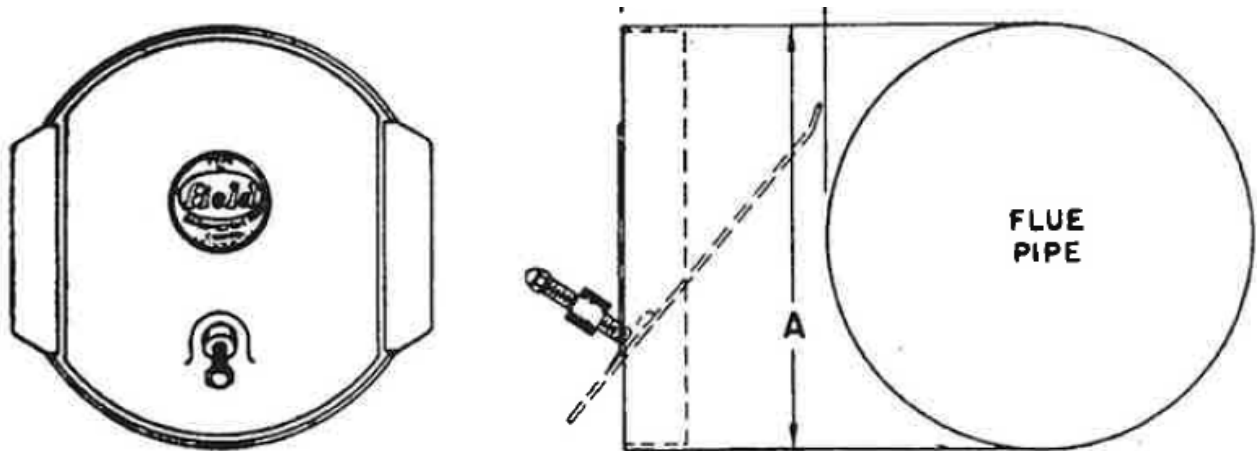

Section 5 - Fuel Supply Tank Installation

General Requirements

- The fuel supply tank and supply lines must be installed in accordance with the National Fire Protection Association requirements, as well as State and Local ordinances.
- Check state and local codes. In many areas, regulations require oil storage tanks located inside not to exceed 275 gallons individually, and are not to exceed a total capacity of 550 gallons in one building.
- Locate the fuel supply tank inside the building, as close to the heater as possible while maintaining the minimum 6 feet clearance. To avoid issues with fuel flow, the tank should be located no further than 100 feet from the heater.
- The fuel supply tank must be mounted below the burner and the bypass regulator (or supply pump assembly when using the optional metering pump). Mounting the fuel supply tank above the burner will create head pressure and over-fire the burner voiding the warranty.
- Pitch the fuel supply tank 2° with the drain valve at the lowest end of the tank, to drain off water and sludge. Sludge may have to be removed manually.
- **In many areas, local ordinances require the fuel supply tank to have an emergency vent and/or be vented to building's exterior above the roofline. Check State and Local codes. Keep the vent clear.**
- If mounting the heater to the tank, bolt the tank to the floor before beginning to install the heater.
- The top port nearest to the tank drain should be used for filling the tank.
- Label the fuel tank for the recommended fuels.
- Strain all fuel with a 50 X 50 mesh strainer before putting fuel into the tank.
- When filling the fuel tank with a motorized pump, never leave unattended to prevent over filling and/or spillage.
- Keep all tank ports except vent(s) closed when not filling the tank.

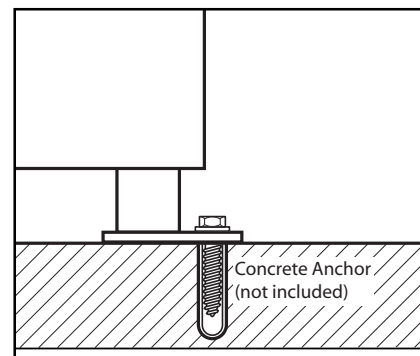

CAUTION



Install equipment in a location that is protected from vehicle traffic. Secure tank/heater/plumbing to permanent structure before fueling/running the system.



Section 5 - Fuel Supply Tank Installation

Tank-Mounted Installation

Many installations take advantage of Lanair's prefabricated tank-mounting hardware to simplify the installation and operation of the heater.

- After anchoring the tank to the floor, install the support legs and heater platform using the hardware provided with the kit.
- Use a forklift to lift and align the heater with the front and center of the platform.
- Locate the four holes in the bottom of the heater platform and attach the heater to the platform with the #10-1" screws provided.

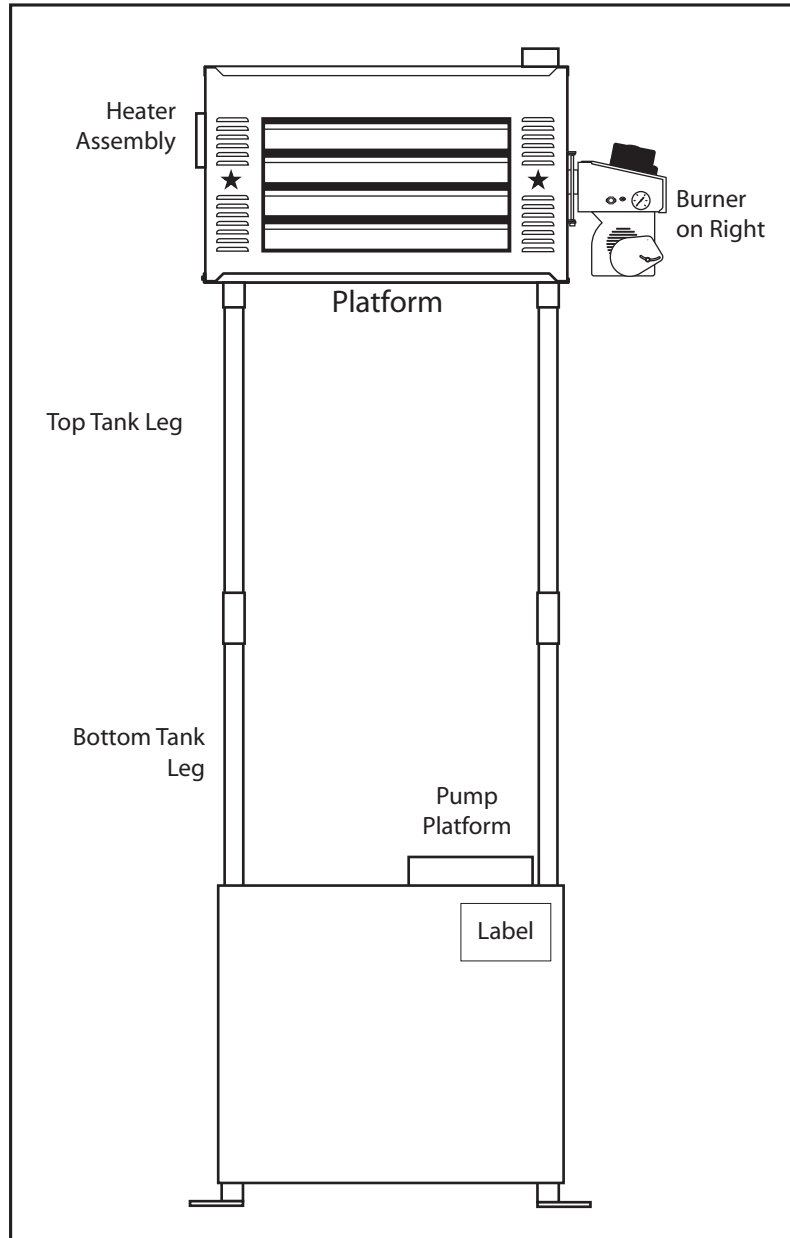

CAUTION



For optimum performance, the waste oil pump manufacturer recommends that multi-weight oils such as 5W-30 be maintained at 32° F minimum and straight weight oils such as 40W and 50W be maintained at 50° F minimum.

QUESTIONS?... Contact Customer Service at 1-888-370-6531 M-F 8:00 am- 4:15 pm CST

Section 5 - Fuel Supply Tank Installation

Bypass-Regulator Pump Installation

The oil-pressure bypass regulator pump maintains consistent fuel pressure to the burner and returns excess fuel / fuel pressure to the tank. The regulator controls the amount of oil being supplied to the burner and allows for adjustments.

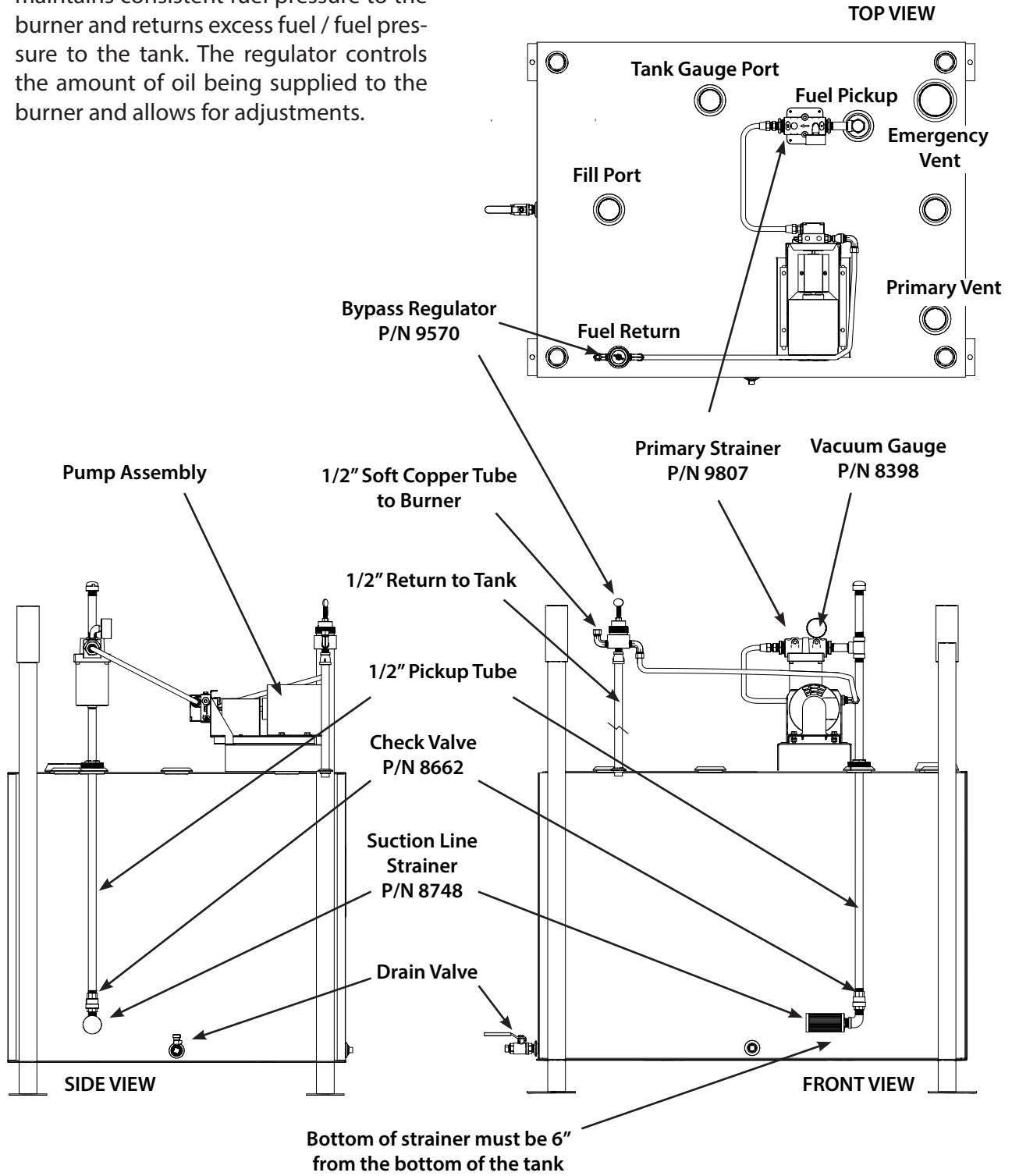

Visit our website at: www.lanair.com



Section 5 - Fuel Supply Tank Installation

Metering Pump Installation

A metering pump will slowly supply the precise amount of fuel for your heater model. This minimizes the need for flame adjustments and allows for pumping over longer distances (up to 100 ft.), when necessary.

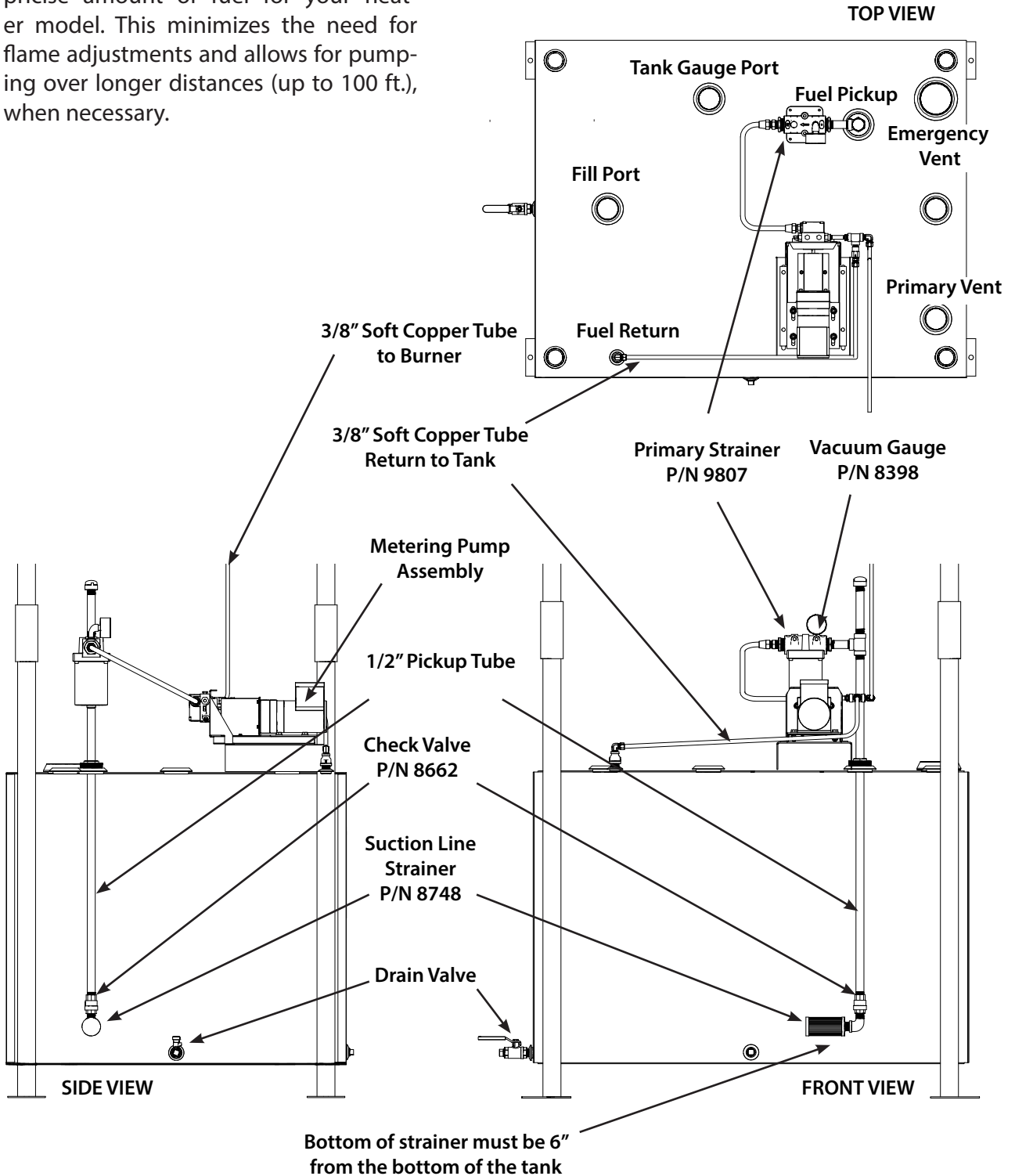

QUESTIONS?... Contact Customer Service at 1-888-370-6531 M-F 8:00 am- 4:15 pm CST

Section 6 - Fuel Supply Pump/Piping

General Requirements

1. Mount the fuel supply pump in a horizontal position (shaft horizontal) near the fuel supply tank.
2. The standard oil pump has a maximum suction lift of 14 feet (6 feet for a metering pump). Suction lift is the length of pipe run from the bottom of the pick-up strainer to the fuel supply pump. Tall tanks and/or cold fuel may require additional fuel-delivery equipment to properly supply the heating system.
3. The fuel pump/motor are intended for indoor use only.
4. **Clean all lines, fittings, and parts internally before assembly.** A small burr or piece of rust could plug the nozzle. See Section 5 for an illustration of a typical pump and piping installation.
5. The fuel pump contains an internal strainer that periodically needs to be cleaned. This internal strainer is mounted behind the pump cover. Before removing the pump cover make sure you have a new gasket on hand. Contact the Lanair Customer Service Department for the proper gasket for your model of pump, at 1-888-370-6531.
6. Use 1/2" interior diameter (.493) steel pipe, or 1/2" outside diameter copper throughout the suction supply line and pick up tube. The use of smaller line, rubber, plastic or hydraulic line is unsafe and will void your warranty.
7. Use thread sealing compound on all pipe thread connections. **Do Not Use Teflon Tape.**
8. Install the suction line strainer in the suction line. Make sure the suction line strainer is 6" off the bottom of the tank. The suction line strainer may be mounted horizontally or vertically. Consider accessibility.
9. Install the check valve (arrow facing towards the pump) on the bottom of the pick up tube.
10. Install a vacuum gauge on the primary strainer assembly. This gauge will indicate when service is needed on the strainer, pump or connections.
11. When using a bypass regulator, install a 1/2" inside diameter (.493) steel pipe, or 1/2" outside diameter copper from the fuel bypass regulator (port marked "T") to the fuel supply tank. Do not allow this line to protrude into the tank more than 1". **The use of smaller line, rubber, plastic, or hydraulic line is unsafe and will void your warranty.**

When using the optional Metering Pump install a 3/8" copper line from the tee on the metering pump assembly to the fuel supply tank. Do not allow this line to submerge below the level of the oil. The use of smaller line, rubber, plastic, or hydraulic line is unsafe and will void your warranty.



Section 6 - Fuel Supply Pump/Piping

12. Do not allow the fuel level in the tank to cover the outlet of the return line.
13. When using a bypass regulator install the fuel supply line from the fuel bypass regulator (port B) to the inlet port on the left side of the burner using 1/2" inside diameter (.493) steel pipe, or 1/2" outside diameter copper tubing. The maximum distance of this line is 25 feet. The fuel supply line must be run below the burner at all times. If the fuel supply line runs above the burner it will create head pressure. This head pressure will over-fire the burner voiding the warranty.

When using the optional metering pump install the fuel supply line from the pump assembly to the burner.

14. Keep the fuel supply lines a minimum of 1" from any exterior walls of the building.
15. **The fuel supply line must gradually rise to the burner. It should not be higher than the burner. Avoid creating any high points in the line that will trap air bubbles.**

Oil-Pressure Bypass Regulator

- B.** Port to the oil inlet on the burner assembly. Install 1/2" O.D. (min.) copper tubing. Failure to install this line properly will result in damage to your heater and will void your warranty.
- T.** Port to the oil supply tank for the overflow return line. Install 3/8" nipple, 1/2" x 3/8" reducer, and 1/2" schedule 40 pipe. **This line MUST run straight into the tank, and should not be submerged in oil. No elbows should be used. Failure to install this line properly will result in damage to your heater, and will void your warranty.**
- P.** Port from the outlet side of your fuel supply pump. Install 1/2" O.D. min. copper tubing. **Failure to install this line properly will result in damage to your heater, and will void your warranty.**

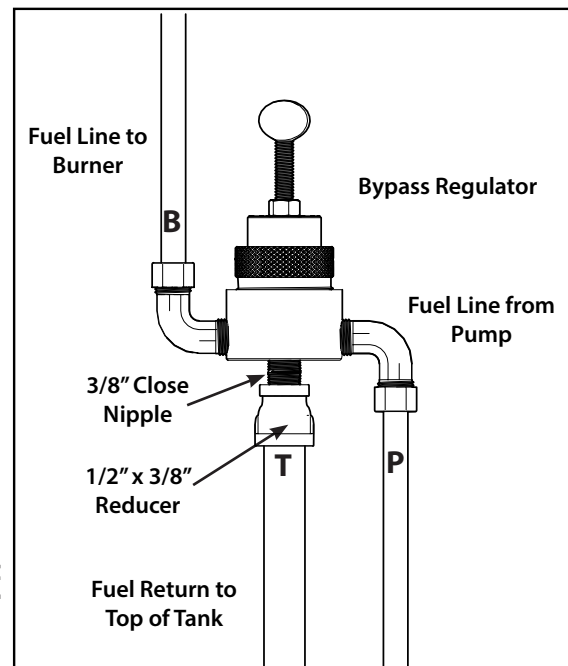

Section 7 - Air Supply Installation

General Requirements

1. The air supply source must be capable of producing 2.0 CFM @ 30 PSI.
2. Install a shut off valve in the air supply line for service.
3. **CAUTION** Install a primary air filter/regulator with a gauge (capable of reading line pressure) in the air supply line prior to the air filter/regulator mounted on the furnace. The primary air filter/regulator **is not supplied** with the furnace.
4. If the primary air regulator does not have a filter with a bowl, a condensate drain leg must be installed in the air supply line.
5. Install a quick disconnect at the air filter/regulator on the furnace for service.
6. For the ease of installation install a flexible airline (0.250 I.D. minimum) from the quick disconnect to the primary air regulator.
7. The air supply line must be pitched uphill from the primary regulator to the furnace to prevent condensation from entering your burner.
8. Open all air shutoff valves, and set the primary air regulator at 30 PSI. Make final setting with heater running.

Example air-pressure supply installation:

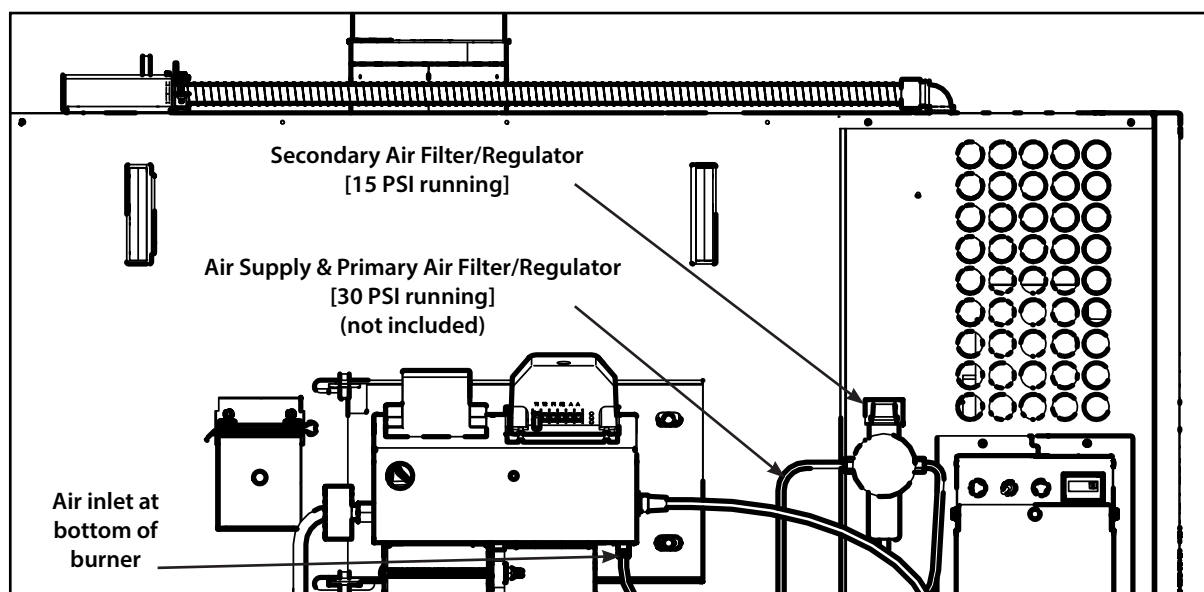

Visit our website at: www.lanair.com

⚠ WARNING



WARNING: HAZARD OF ELECTRICAL SHOCK!

Main Electrical Installation

1. All wiring must comply with the National Electrical Code, state and local ordinances, and be wired by a qualified electrician.
2. **Electrical service MUST be connected to a separate 20 AMP, 115 VAC, 60 HZ single phase circuit.**

Note - A 30 Amp breaker may be necessary depending on heater size, pump selection and if using the optional compressor (See data label on heater for amperage specific to your configuration). A qualified electrician should confirm breaker and wire sizes in accordance with all applicable electrical codes.

3. Electrical service connections are made in the electrical junction box on the side of the heater.
4. The heater must have a safety equipment ground from the main electrical service, strand-
ed 12 GA minimum.
5. The electrical conductors for electrical service to the heater MUST be stranded 12 GA
minimum.
6. Install a manual service disconnect near the heater, and label it.
7. The supply voltage must be maintained at a minimum 110 VAC.
8. The electrical conductors from the main electrical service must be within approved con-
duit.
9. Keep all electrical conductors and conduit away from the chimney connector as well as any
other hot surfaces. Keep the power off until the heater is ready to be started.

Remove wires from the block by inserting a small flat tip screwdriver into the top slot. Push tip all the way down and push forward. Remove wire.

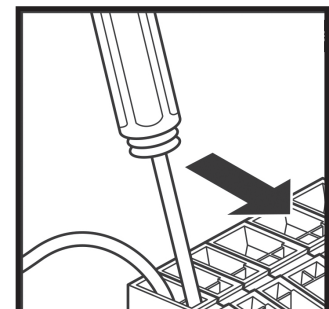

Section 8 - Electrical Connections

Burner Wiring Diagram

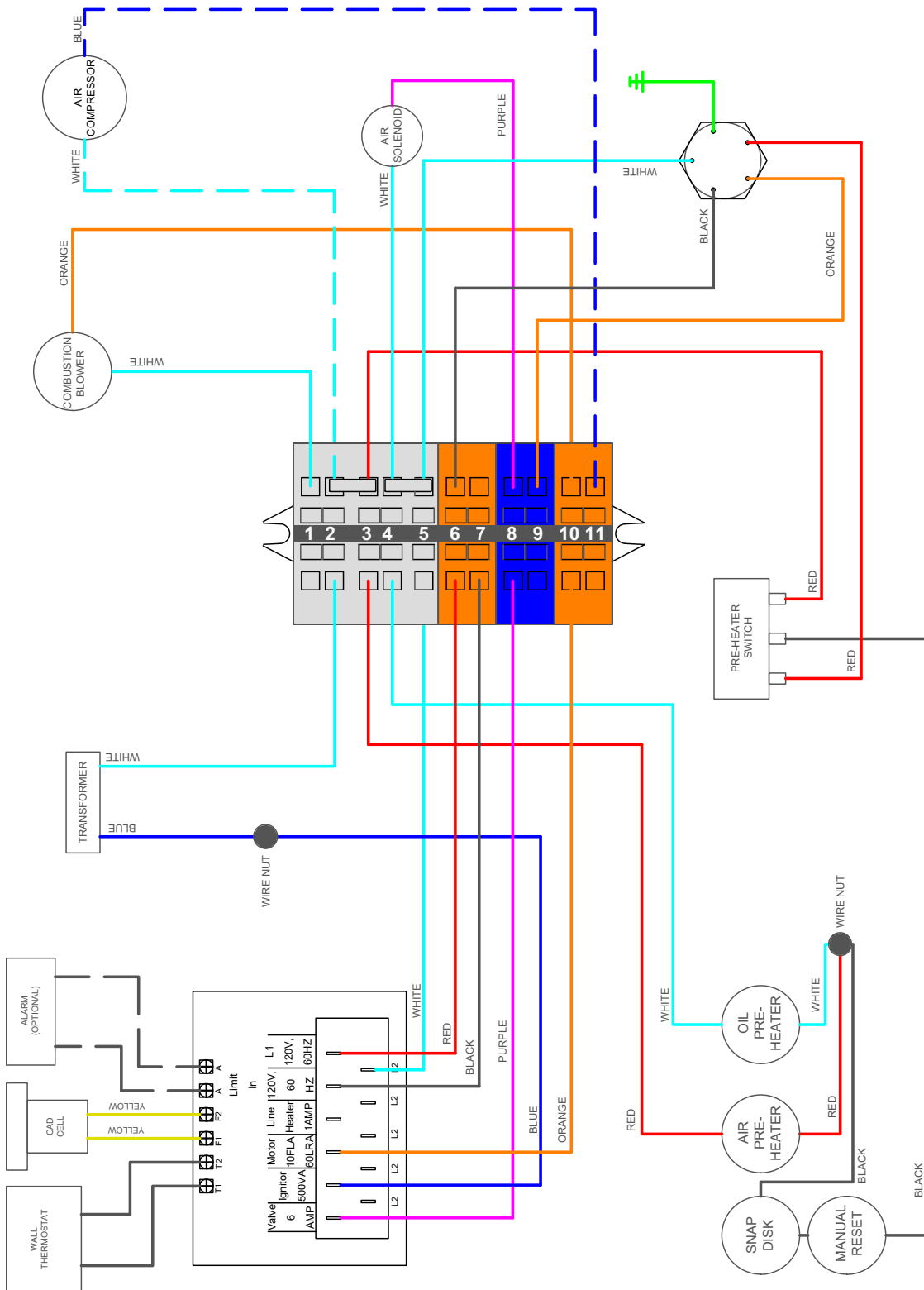

Visit our website at: www.lanair.com



Section 8 - Electrical Connections

Electrical Junction Box Diagram (XT : Non-Ductable)

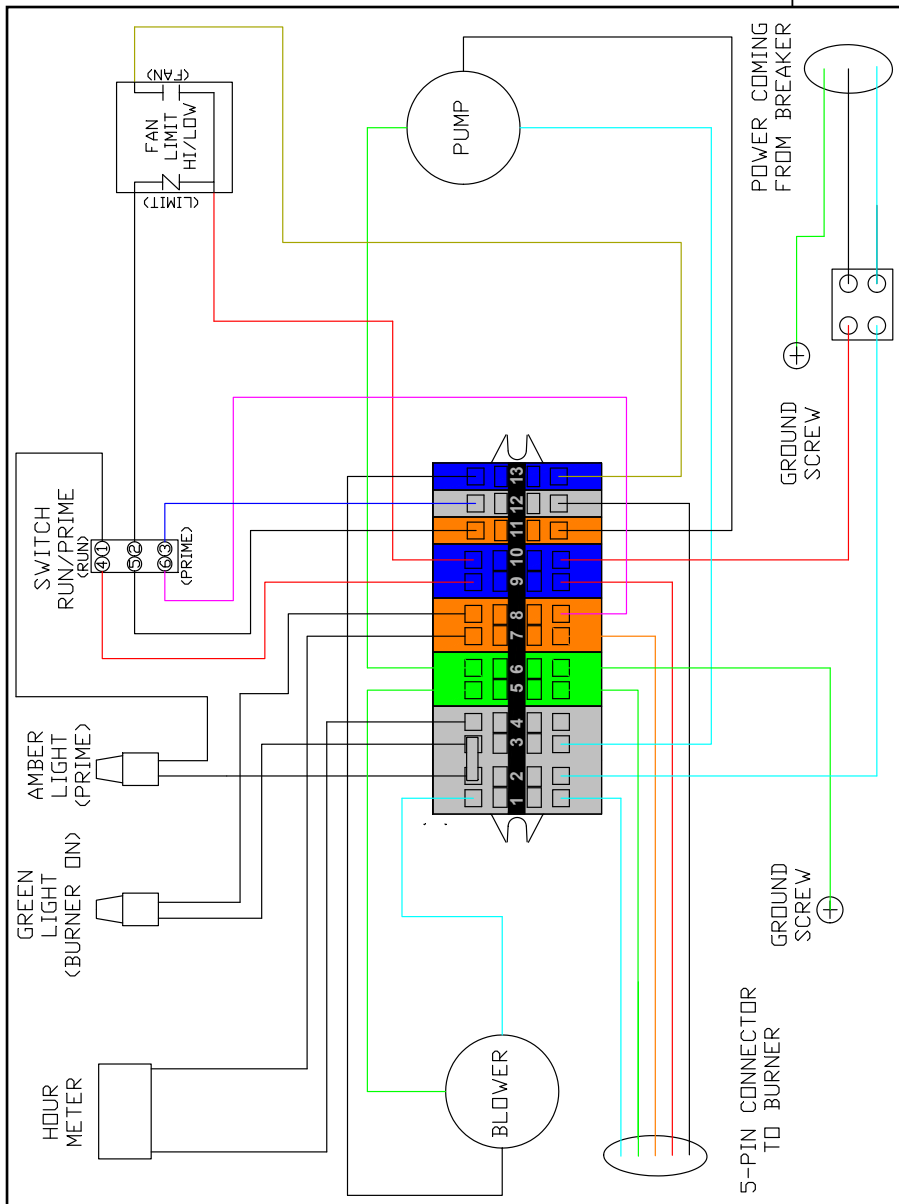

Metering Pump (Alternative Wiring)

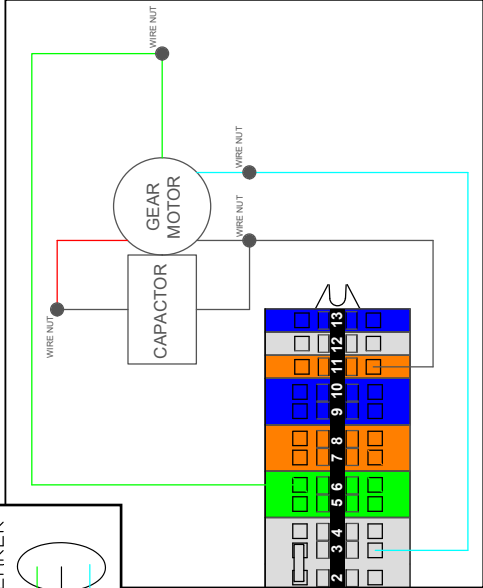

QUESTIONS?... Contact Customer Service at 1-888-370-6531 M-F 8:00 am- 4:15 pm CST

Section 8 - Electrical Connections

Electrical Junction Box Diagram (XTD : Ductable)

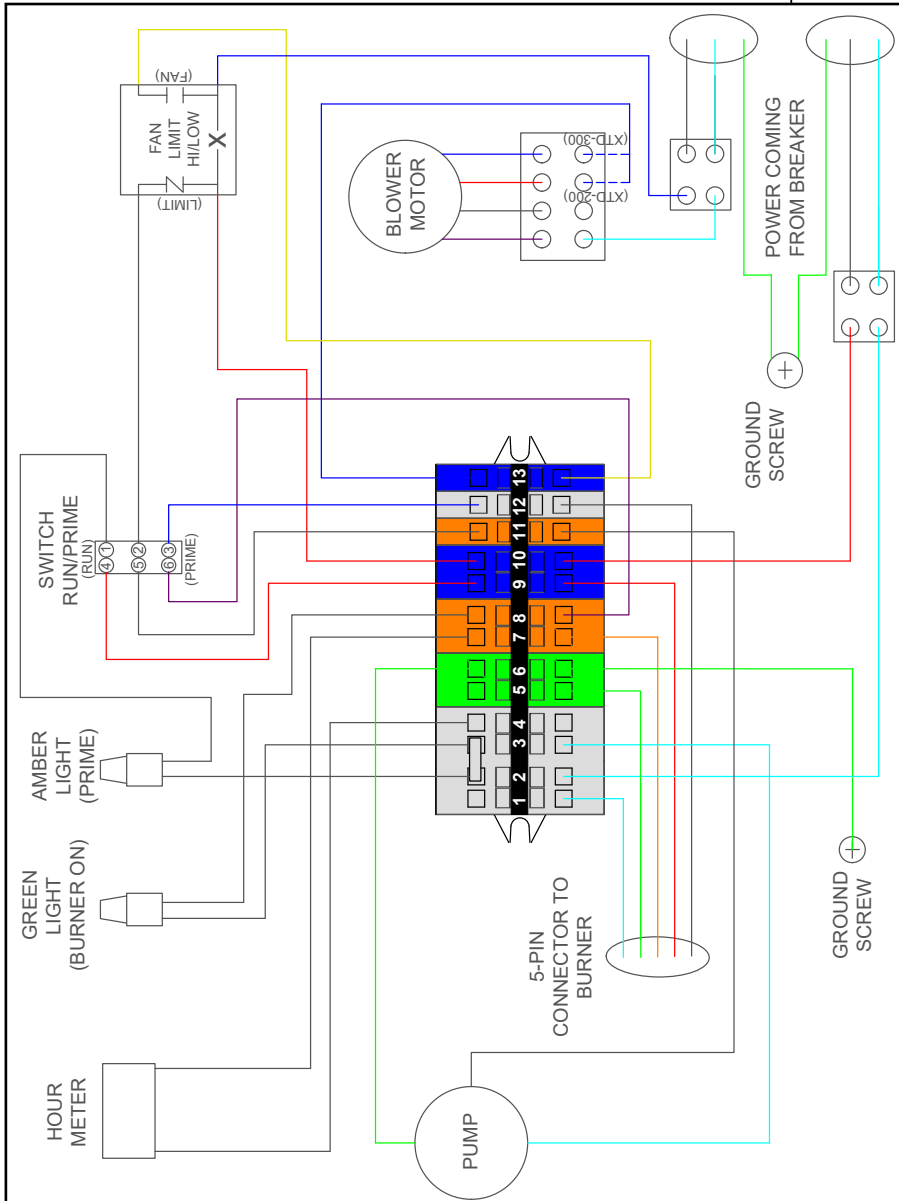

Metering Pump (Alternative Wiring)

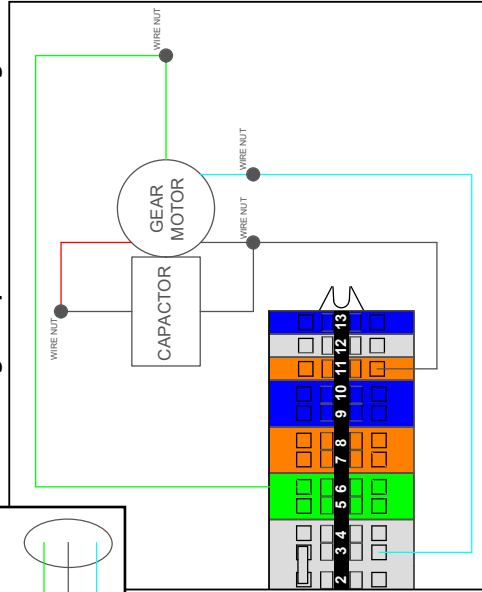

Visit our website at: www.lanair.com



▲ WARNING



WARNING: HAZARD OF ELECTRICAL SHOCK!

Fuel Supply Pump Electrical Installation

1. All wiring must comply with the National Electrical Code, State and Local Ordinances, and be wired by a qualified electrician.
2. The electrical conductors to the fuel pump motor **MUST** be stranded 14 GA minimum.
3. The electrical service connections for the fuel pump motor are made in the electrical junction box on the side of the heater.
4. The pump motor **MUST** have a safety equipment ground from the main electrical service, stranded 14 GA minimum.
5. The electrical conductors from the electrical junction box to the pump motor must be within approved conduit.
6. Keep all electrical conductors and conduit away from the chimney connector as well as any other hot surfaces. Refer to Wiring Diagram for color code, etc. Connect wiring to the L1 and L2 terminals of the fuel pump, but do not turn the power on until the heater is ready to be started.

Room Thermostat Installation

1. All wiring must comply with the National Electrical Code, State and Local Ordinances, and be wired by a qualified electrician.
2. Install the room thermostat in accordance with the directions furnished with the thermostat.
3. Use two conductor thermostat wire (24 AWG minimum) for the connection of the thermostat to the T1-T2 terminals of the oil primary control that is mounted on top of the burner.
4. Mount the thermostat 5 feet above the floor on an inside wall away from the heater's warm air path.
5. The electrical current for thermostat is 24 V, and is provided by the oil primary control.
6. Keep the thermostat wire away from the chimney connector, or any other hot surfaces. Refer to Section 2 for a typical thermostat installation.

Section 9 - Priming The Fuel Pump

Priming The Fuel Pump

1. The fuel level in the supply tank must be above the check valve on the pick-up tube
2. Remove the cap from the fill pipe at the suction line strainer, and fill with clean used oil. Securely replace the fill-pipe cap.
3. When using the bypass regulator, back the thumb screw out (CCW) on the bypass regulator until it is free, then turn (CW) two turns to seat the diaphragm.
4. Loosen the bleeder screw on the pump one turn and position a container below it to catch any oil that is emitted.
5. Toggle the priming switch to the "PRIME" position.
6. When a steady stream of fuel (no air bubbles) begins to flow, close the bleeder screw.
7. Toggle the priming switch to the "RUN" position.
8. Remove the fuel supply line from the burner, and position a container to catch the fuel.
9. Toggle the priming switch to the "PRIME" position.
10. Observe the end of the fuel supply line that is disconnected from the burner. Allow a steady stream (no air bubbles) of fuel to flow into the container for several minutes. This will flush any debris from the fuel line that could potentially plug the nozzle. The vacuum gauge reading should not exceed 5" HG of vacuum.
11. Toggle the priming switch to the "RUN" position.
12. Reconnect the fuel supply line to the burner.

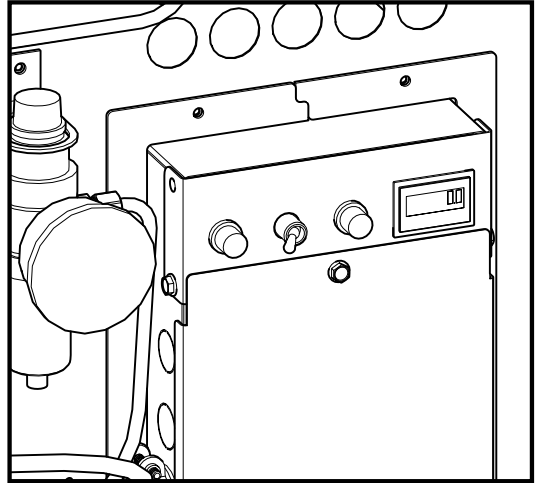

The burner should now be ready for normal operation.



Section 10 - Burner Startup Procedure

Waste Oil Burner Start-Up

1. Make sure the main electrical service for the heater is turned off, and locked out.
2. Check for proper draft in the chimney. Confirm that there is no positive-draft pressure (air coming DOWN the chimney, usually caused by roof-vent exhaust fans).
3. Make sure there is air pressure at the heater's air filter/regulator, set at 20 PSI (idle pressure, 15 PSI while heater is running). Set the primary regulator on the air supply line to 30 PSI.
4. Ensure that the fan/limit control switch is set to automatic.
5. Set the room thermostat below room temperature (OFF).
6. Turn the main electrical service ON.
7. If using waste 5W-50W used oil, flip the pre-heater rocker switch on, light ON, and wait 5-7 minutes for the pre-heater assembly to reach operating temperature. Leave the preheater switch OFF if using No. 2 fuel oil.
8. Set the air-baffle position according to your unit:

XT-150	≈ 1/4 open (burner air-intake grill 25% exposed)
XT(D)-200, XT-250	≈ 1/2 open (burner air-intake grill 50% exposed)
XT(D)-300	≈ 3/4 open (burner air-intake grill 75% exposed)

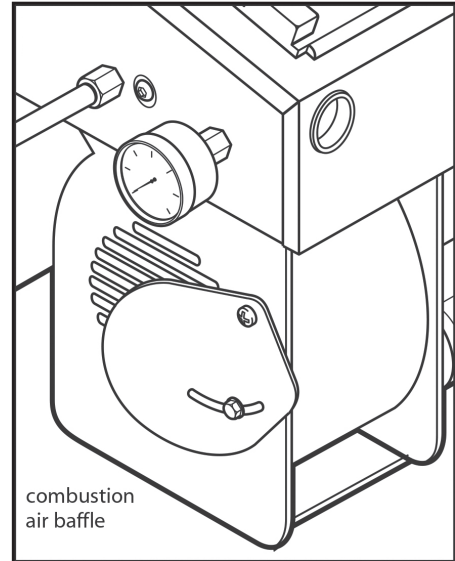

These are preliminary positions for the air baffle and may be adjusted during a later step.

9. Turn the room thermostat up above the room temperature. The burner will now fire. Check the sight glass on the rear of the burner. Also inspect the flame through the inspection port. (See Section 11 - Flame Adjustment).
10. Adjust the burner air filter/regulator to 15 PSI (running pressure), and the primary air regulator to 30 PSI.

NOTE: 15 PSI on the air filter/regulator is the starting point, you may need to adjust from there when **VISUALLY SETTING THE FLAME** (See Section 11, flame adjustment).

CAUTION



The combustion air baffle is NOT factory set! See Section 11 - Flame Adjustment

QUESTIONS?... Contact Customer Service at 1-888-370-6531 M-F 8:00 am- 4:15 pm CST

Section 10 - Burner Startup Procedure

11. When using the bypass regulator, adjust the fuel pressure and monitor the gauge on the left side of the burner. Refer to the following table for recommended settings:

Oil-Pressure Bypass Regulator Initial Settings

Model	No. 2 Fuel Oil	Approved Waste Oil
XT-150	0.5 - 1.0 PSI	1.0 - 1.5 PSI
XT(D)-200	1.5 - 2.0 PSI	2.0 - 2.5 PSI
XT-250	2.5 - 3.0 PSI	3.0 - 3.5 PSI
XT(D)-300	3.0 - 3.5 PSI	3.5 - 4.0 PSI

NOTE: Adjust the thumb screw on the fuel bypass regulator clockwise to increase pressure, and counter clockwise to decrease pressure to the burner. The oil pressures listed above are a starting point, you may need to adjust from there when **VISUALLY SETTING THE FLAME** (See Section 12 - Flame Adjustment).

NOTE: When using the **metering pump**, the fuel flow is determined by the pump. Pressures may not be the same as shown above and do not need adjustment.

12. Adjust the barometric damper to obtain a draft of -0.05 W.C. while the heater is hot and operating.

NOTE: It is **VERY IMPORTANT** that the barometric damper is set to the required settings to ensure the natural draft of exhaust gases (see section 4).

13. Depending on the type of fuel used, the elevation, temperature, and oil viscosity, the combustion air baffle will need to be adjusted for optimum performance (See Section 12 - Flame Adjustment).

14. When the room thermostat setting is met the burner will shut off, but the fan will continue to operate until the cabinet temperature drops to 90° F, or below.

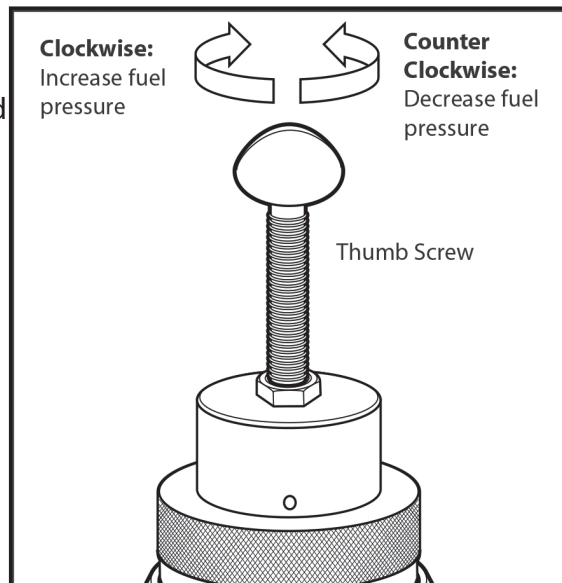

Fuel Bypass Regulator
(not used with optional metering pump)

CAUTION



The combustion air baffle is **NOT** factory set! See Section 11 - Flame Adjustment



Flame Adjustment

1. Start the heater, let it run for at least 15 minutes to reach operating temperature before proceeding.
2. Check the chimney draft, set the barometric damper to -0.05 WC when hot and running.
3. Check the atomizing air pressure, set the air filter/regulator on the heater:
XT-150, XT(D)-200 = 12-15 PSI
XT-250, XT(D)-300 = 15-18 PSI
4. Ensure that the initial fuel pressure is set according to the table in Section 10 - Burner Startup Procedure.
5. When using the bypass regulator, adjust the thumb screw on the fuel by-pass regulator. Lock into position. The flame should extend no more than 3/4 of the way into the chamber.

NOTE: Mechanical equipment like gauges and regulators are not always 100 percent accurate,
VISUAL INSPECTION OF THE FLAME IS REQUIRED

CAUTION



The combustion air baffle is NOT factory set!

Section 11 - Flame Adjustment

⚠ CAUTION



NOTE: ALWAYS WEAR EYE, FACE AND BREATHING PROTECTION AND PROTECTIVE CLOTHING WHEN INSPECTING OR ADJUSTING FLAME.

Lift the inspection port cover on the front of the combustion chamber to observe the flame. The flame tips should extend 3/4 of the way into the combustion chamber. When the unit is adjusted properly the ash inside the chamber will be white to off white.

Flame tips touching the target brick (end of the chamber) will cause combustion chamber damage. This condition may be caused by a worn nozzle, not enough combustion air, or excess burner fuel pressure. When this condition exists, the ash in the chamber will be brown to black.

Flame Adjustment - Visual

Flame is over-fired

- Dark yellow, to orange in color.
- The flame is hitting the walls, filling the chamber with a smokey flame. Correct immediately or chamber may be damaged.

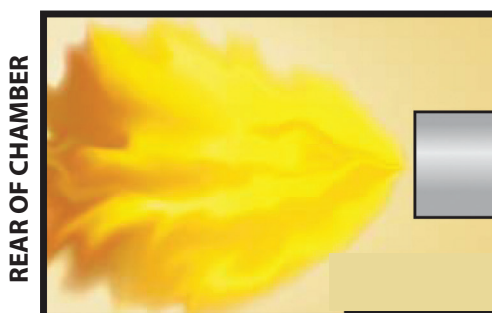

Flame is over-fired

Problem: Too large of a flame, dark yellow in color. Ash inside the chamber is dark brown to sooty-black in color

- **Too much fuel pressure:** decrease fuel pressure at bypass regulator (not applicable for metering pump)
- **Not enough combustion air:** increase opening of burner air baffle
- **Not enough atomizing air pressure:** increase atomizing-air pressure (adjust in 1 psi increments; too much atomizing air can also cause "pulsing" of flame)
- **Oil too cold:** check to see if preheater block is hot

⚠ CAUTION



DO NOT OVER FIRE YOUR HEATER. IMMEDIATELY ADJUST THE BURNER TO THE PROPER FLAME LENGTH TO PREVENT DAMAGE TO YOUR HEATER.

CAUTION



CHECK FLAME DAILY (see page 37). ADJUST ACCORDINGLY

Visit our website at: www.lanair.com

Flame is under-fired

- The flame is very short and/or flickers.
- Light yellow, to white in color.



Flame is under-fired

Problem: Too small a flame, flame “pulses”, or “sparklers” are visible.

- **Too much atomizing air pressure:** decrease atomizing-air pressure (adjust in 1psi increments)
- **Too much combustion air pressure:** close the burner air baffle slightly until flame is CORRECT
- **Not enough fuel pressure when using a bypass regulator:** increase fuel pressure at bypass regulator (not applicable for metering pump)
- **Oil too cold:** check to see if preheater block is hot

Flame is CORRECT

Bright-yellow in color.

- Flame extends 3/4 into the chamber
- Flame is not impinging on the chamber walls
- No black smoke coming from the chimney
- Ash inside the chamber is white to off white in color



Flame is CORRECT

If you need assistance with flame adjustment, please call Lanair's Parts and Service Department.

Section 12 - Service / Maintenance

XT SERIES HEATER SERVICE / MAINTENANCE SCHEDULE

DAILY	WEEKLY	MONTHLY	ANNUALLY (Season Shut Down)
<ul style="list-style-type: none"> • Check fuel supply tank level (pre-strain all fuels). • Check vacuum gauge reading on suction line. • Check atomizing air pressure at the air filter/regulator. Verify pressure setting. Drain water from the bowl if necessary. • Check the fuel pressure gauge on the burner. Set to the correct pressure for the fuel being used. (only when using a bypass regulator) • Visually inspect flame. Adjust accordingly. NOTE: Wear adequate eye, face and breathing protection. • Check draft using a manometer. Set draft to -.02 cold, -.05 hot. • If heater is not to be used for more than 12 hours (overnight) flip the pre-heater rocker switch off (light off). 	<ul style="list-style-type: none"> • Drain water/anti-freeze from the fuel supply tank. • Check the air pressure setting on the primary air regulator. • Set to 30 psi. • Drain water from the air pressure supply line drain leg and primary regulator. • Inspect the combustion, ash build-up and flame. <p>NOTE: Wear adequate eye, face and breathing protection.</p>	<ul style="list-style-type: none"> • Check combustion chamber and heat exchanger. Clean if necessary. Inspect fire brick. <p>NOTE: Wear protective clothing, adequate eye, face and breathing protection. Do not breathe dust from the combustion chamber. Wash thoroughly with soap and water after cleaning chamber.</p> <ul style="list-style-type: none"> • Clean the chimney, chimney connector and barometric damper. • Clean pump strainer, suction line strainer and pick-up tube-strainer. <p>NOTE: Always prime pump after cleaning strainers.</p> <ul style="list-style-type: none"> • Check for dirt build-up on the combustion blower wheel. Keep wheel clean. • Check nozzle and turbulator for oil build-up; clean / adjust if necessary. 	<ul style="list-style-type: none"> • Flip air/fuel pre-heater switch off. • Shut off main power supply to heater. • Perform monthly service/maintenance. • Shut off air supply. • Lubricate all motors following specifications on the motor rating plate. • Clean fuel pump strainer. • Drain and clean fuel supply tank. • Clean combustion blower, axial fan and blades

Remove ash from combustion chamber and heat-exchange tubes every 750-1000 hours of run time and at the end of every heating season.

Cleaning the Primary Strainer

The primary strainer should be inspected / cleaned every 30 days of operation. The element is a washable metal element. If your waste oil is extremely dirty, this strainer may need to be cleaned more frequently. Your vacuum gauge will help you determine when the filter needs cleaning. The vacuum gauge reading should not exceed 10" HG of vacuum. If it does, the strainer needs cleaning.

1. Disconnect power to the heater.
2. Use a 3/16" hex key to remove the four screws affixing the canister bowl to the filter head.
3. Rinse the filter and lower housing in solvent.
4. Air dry the strainer and lower housing.
5. Re-assemble the strainer, ensuring the rubber gaskets and o-rings are in place.
6. Position the canister bowl to the filter head making sure the o-ring is properly seated. Resecure the filter assembly with the screws removed earlier.
7. Prime the fuel pump (see Section 10).

NOTE: If cleaning the suction-line strainer does not reduce the vacuum to normal levels, remove the fuel-pickup assembly from the tank and clean the fuel pickup strainer.

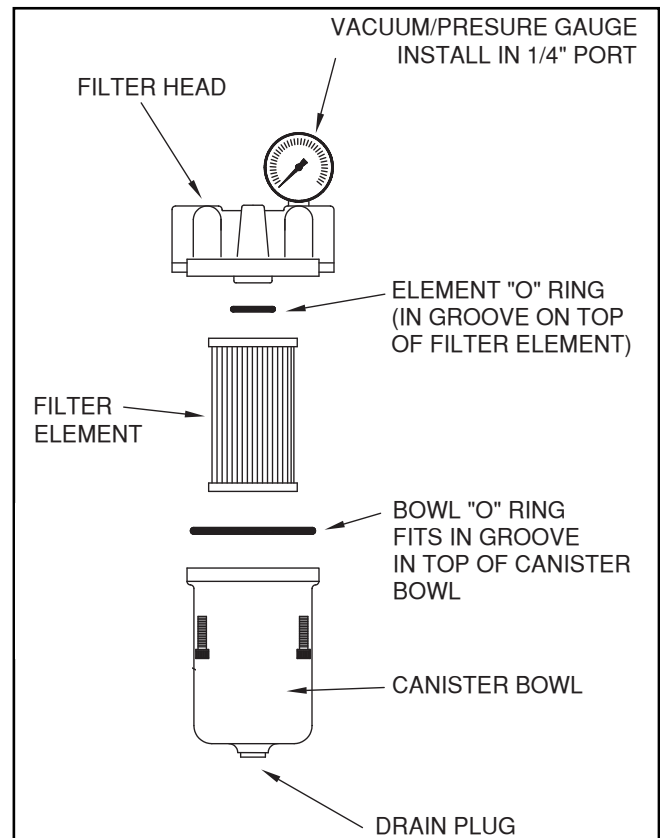

Cleaning/Replacing Fuel Pump Strainer

1. Disconnect power to the heater.
2. Remove four hex head screws from pump cover. Carefully remove cover, strainer and gasket.
3. Clean housing, strainer and pump surface. Check for excess wear.
4. Install cleaned / new pump strainer kit (P/N 32423) then reinstall the pump housing.
5. Prime the fuel pump (see Section 9).

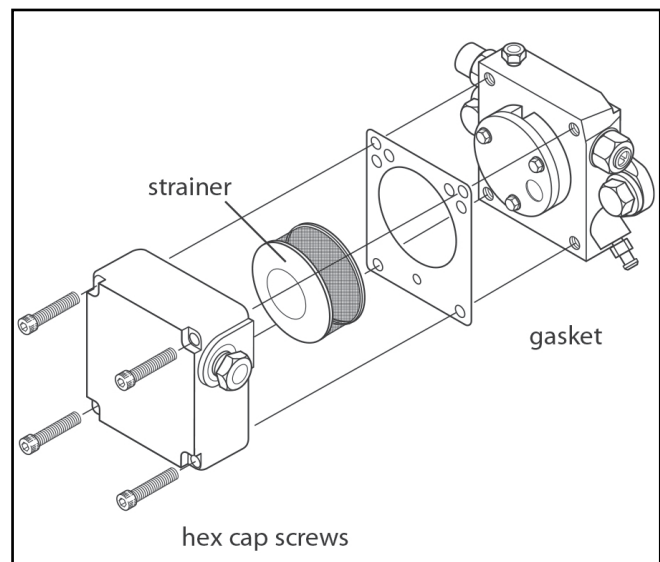

NOTE: BYPASS REGULATOR NOT USED WITH OPTIONAL METERING PUMP

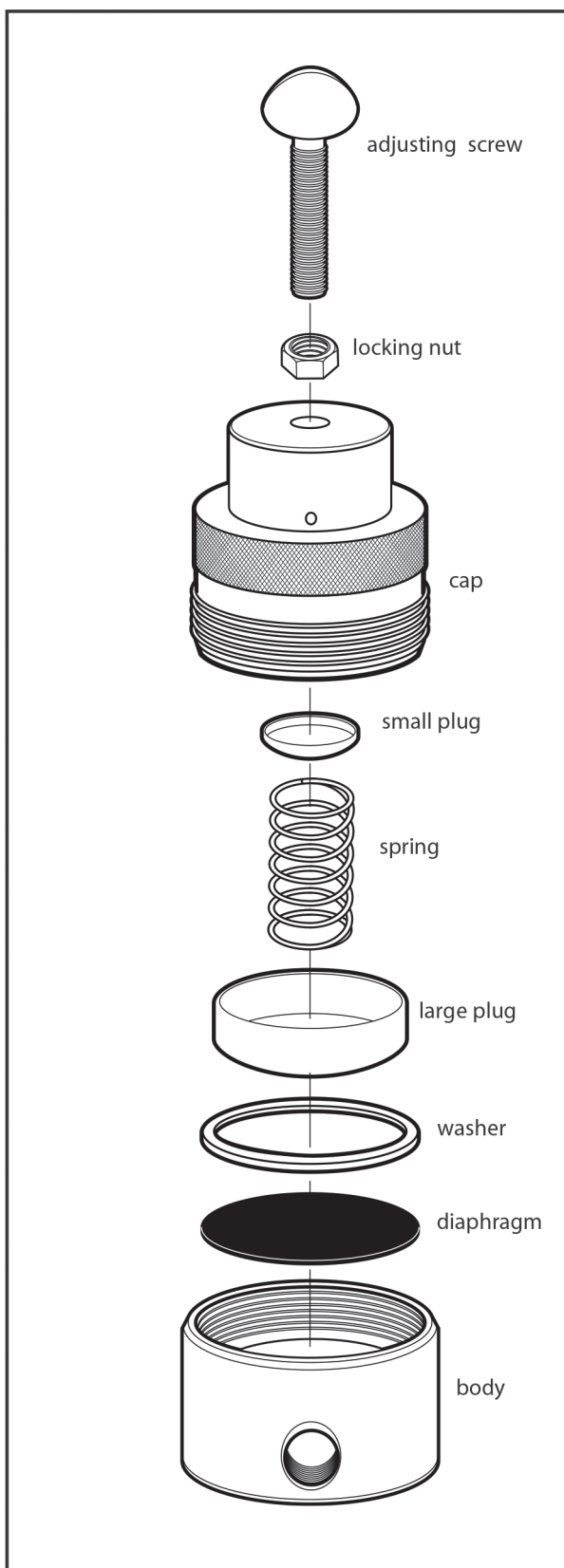

Fuel Bypass Regulator Diaphragm Replacement

1. Disconnect power to the heater.
2. Remove the locking nut and adjusting screw from the bypass regulator assembly.
3. Disassemble the bypass regulator and discard the small plug, spring, large plug, washer and diaphragm parts.
4. Thoroughly clean and dry remaining parts
5. Re-assemble using new small plug, spring, large plug, washer, and diaphragm (Kit P/N 9874).

NOTE: Pay close attention to the positions of the large and small plugs.



Oil Preheater Nozzle-line Assembly

Replacement-assembly Part # 81010396

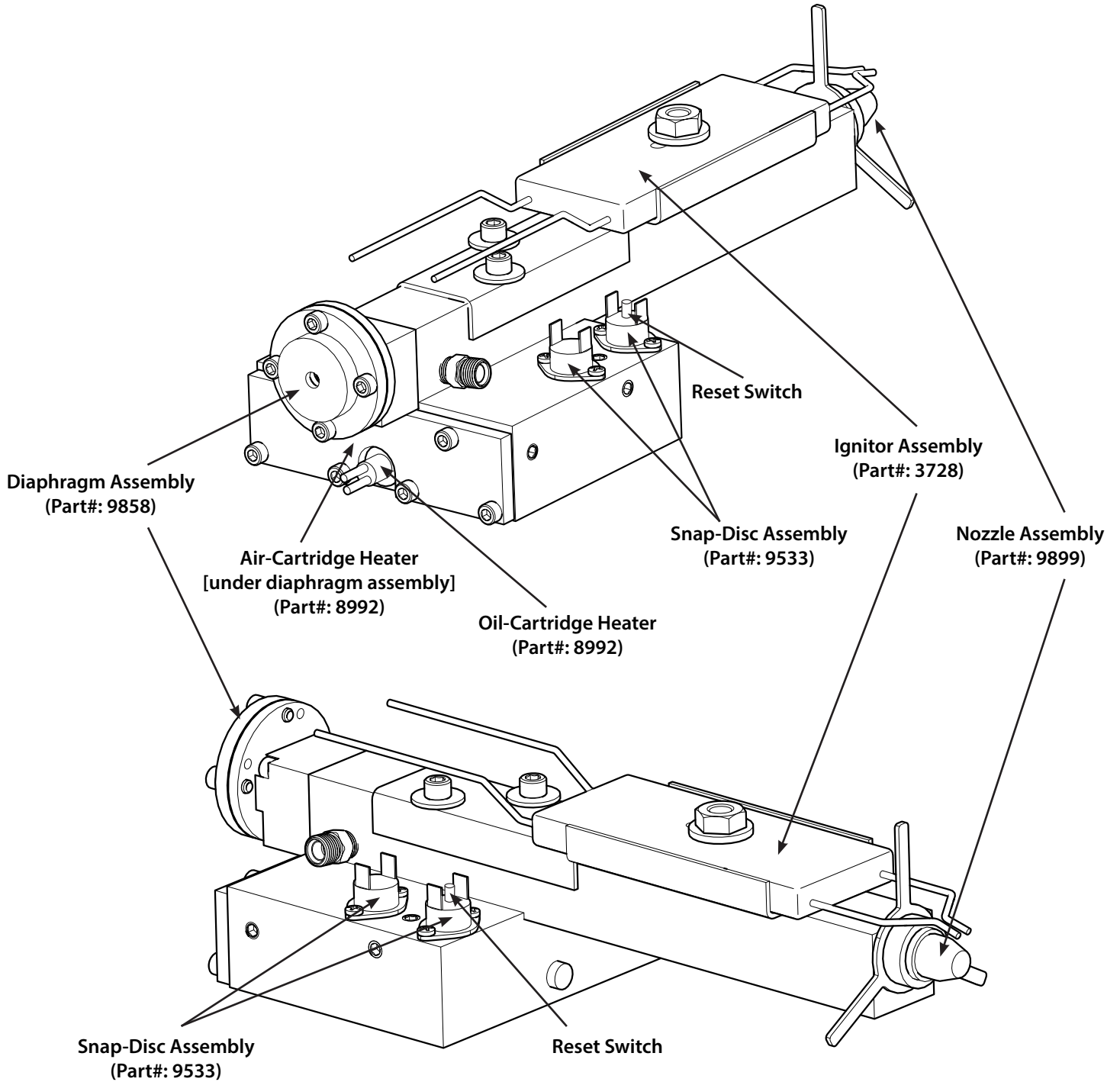

QUESTIONS?... Contact Customer Service at 1-888-370-6531 M-F 8:00 am- 4:15 pm CST

Igniter Replacement / Adjustment

1. Disconnect power to the heater.
2. Access and remove the preheater assembly from inside the burner assembly.
3. Remove the retaining nut and carefully remove the one-piece ignitor from the preheater.
4. Install a new one piece ignitor (P/N 3728) to the top of the preheater, if necessary.
5. Adjust the position of the ignitor and tighten the nut to secure it in place.

The tips of the ignitor should be $3/8$ " above the center of the nozzle assembly and should extend approximately $1/8$ " beyond the end of the nozzle. The gap between the electrode tips of the ignitor should measure $1/8$ " at the closest point.

6. Use the tool included with the heater to set the position of the preheater, then secure it in place.

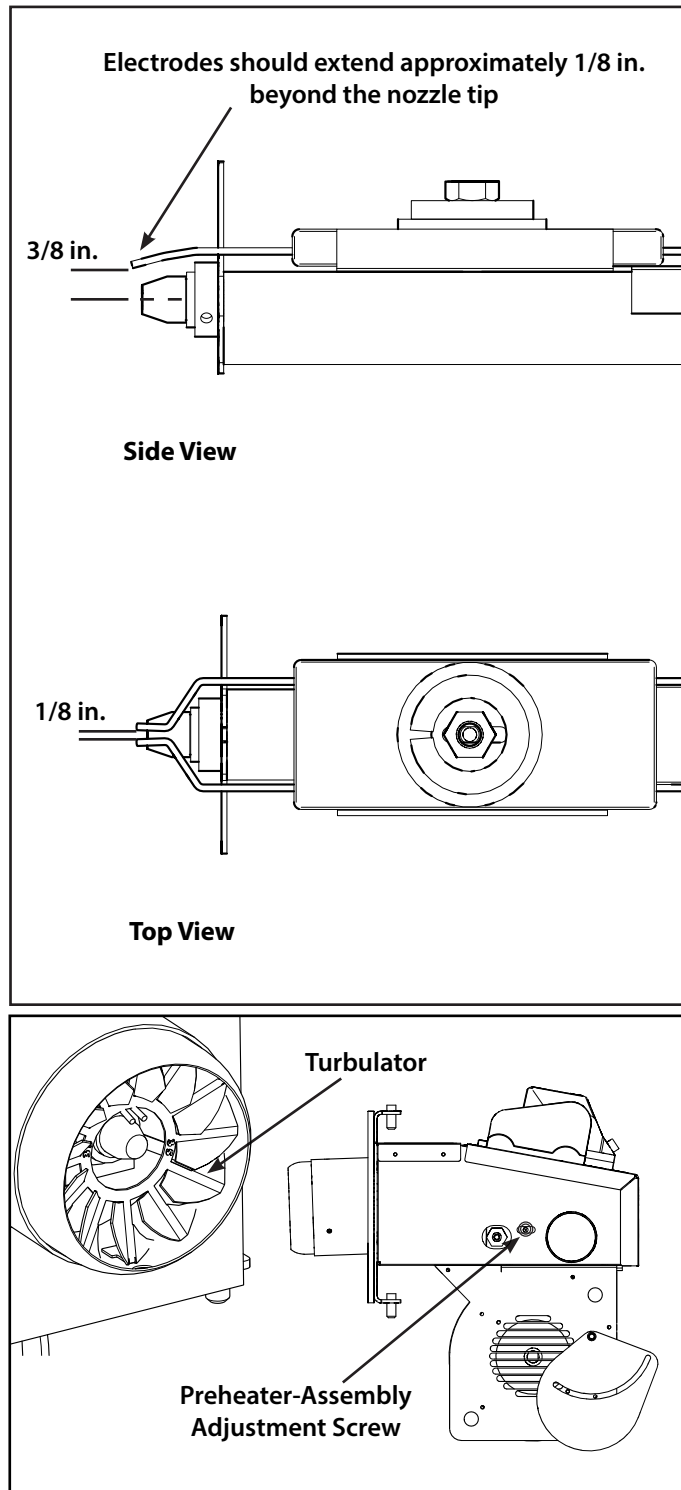

Preheater Diaphragm Breakdown

1. Remove the four hex cap screws from the diaphragm assembly
2. Disassemble and inspect diaphragm, spring and o-ring.
3. Thoroughly clean remaining parts.
4. Re-assemble the diaphragm, o-ring, spring and hex cap screws.

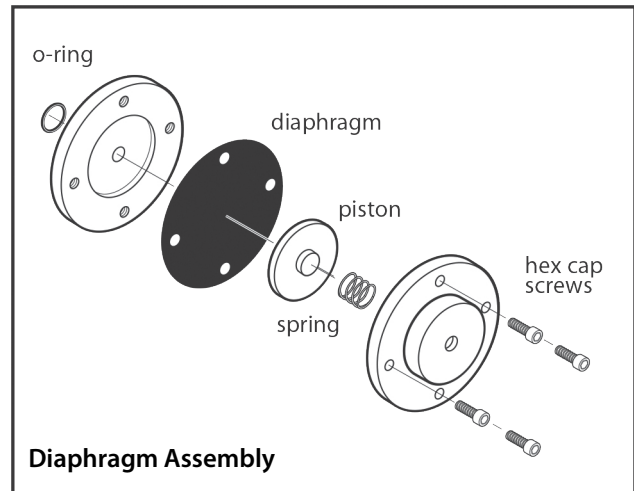

Preheater Nozzle Cleaning / Replacement

1. Periodic cleaning of the nozzle assembly may be required.
2. Carefully remove nozzle from the air preheater block.
3. Disassemble the nozzle as shown and clean thoroughly. Reassemble nozzle.
4. Carefully remove the quad ring from the block and inspect. Replace if necessary.
5. Insert clean/new quad ring into the air pre-heater block.

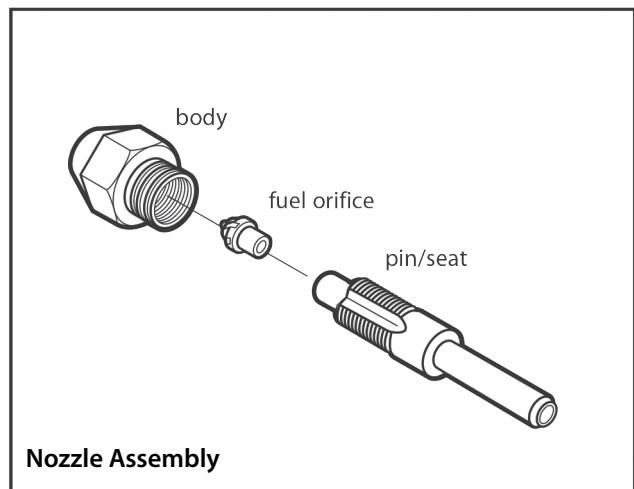

NOTE: The quad ring must be properly seated. Failure to properly seat the quad ring may result in leakage and improper burner operation. **DO NOT INSTALL QUAD RING ON THE NOZZLE.**

6. Lubricate pin/seat and re-install nozzle. Tighten gently.

CAUTION



Failure to properly seat the quad ring may result in leakage and improper burner operation. DO NOT INSTALL QUAD RING ON THE NOZZLE.

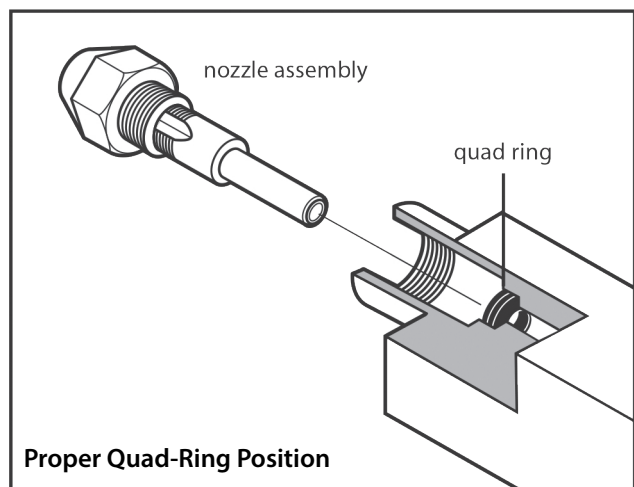

Section 12 - Service / Maintenance

⚠ CAUTION



NOTE: ALWAYS WEAR EYE, FACE AND BREATHING PROTECTION AND PROTECTIVE CLOTHING WHEN INSPECTING OR CLEANING CHAMBER OR HEAT EXCHANGER.

⚠ WARNING



WARNING: DISCONNECT ALL ELECTRICAL POWER TO HEATER BEFORE SERVICING

Cleaning Combustion Chamber/ Heat Exchanger

1. Turn thermostat to the lowest setting; the heater must be completely cool to the touch before attempting to clean the heater (place the fan/limit on the manual position to start the fan and shorten the cooling time if the unit is hot).
2. Turn off all power to the heater (120 VAC) at the main disconnect.
3. Disconnect the burner cord connecting the burner to the heater.
4. Remove the burner and flame view port from the heater.
5. Remove the galvanized panel covering the cleanout door (remove five (5) #10 screws from the top and four (4) #10 screws from the bottom of the panel).
6. **Spray all of the screws with penetrating oil to prevent breakage before removing any of the nuts that secure the combustion chamber access door. Let set for five minutes to allow the oil to penetrate.**
7. Open the clean out door from the heater by removing (8) 1/2 hex head nuts & washers.
8. Clean the heat exchanger chamber and tubes by using an industrial type canister vacuum cleaner with a high efficiency filter, or suitable tool. Remove ash and debris by vacuuming, shoveling, or slowly brushing the ash from the combustion chamber, from the front or rear access. Inspect the combustion chamber and target brick. Use care when cleaning the combustion chamber area so the target brick is not disturbed.

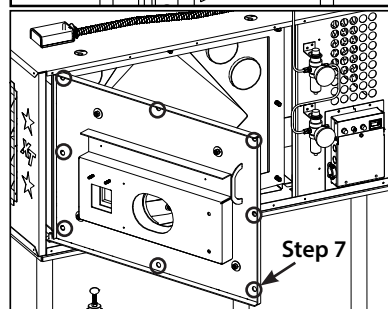
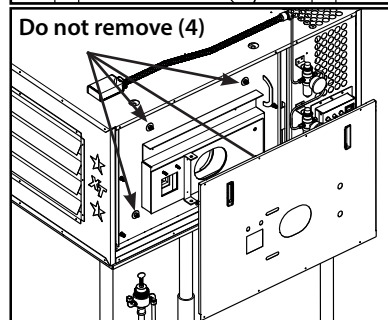
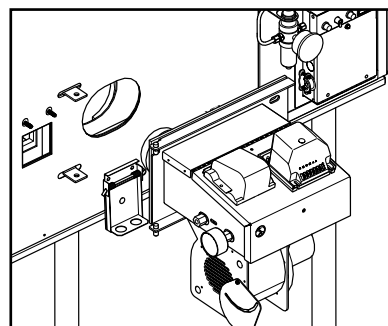

⚠ CAUTION

Insufficient or irregular cleaning intervals will cause inefficiency, random shutdowns, and extreme damage to the combustion chamber.



Section 12 - Service / Maintenance

⚠ CAUTION



CAUTION: THE CLEAN OUT PANEL MUST HAVE AN AIR TIGHT SEAL TO PREVENT EXTREME DAMAGE TO THE COMBUSTION CHAMBER

CAUTION



CAUTION: TO AVOID BOLT BREAKAGE, DO NOT OVER-TIGHTEN

10. Before closing the combustion chamber cleanout door, replace the white gasket seal on the door (contact the Lanair Service Department). When replacing the gaskets apply a light film of gasket adhesive to adhere the new gasket to the door frame. Lube the threads of the screws with a high temperature lubricant (anti-seize). Re-secure the heat exchanger cleanout door. If any nuts are stripped, replace (use brass).
11. Reinstall the galvanized panel, inspection port, and burner.

12. On the side opposite the burner, remove the port cover, as well as the nuts and washers from the access panel.
13. Using an industrial type canister vacuum cleaner with a high efficiency filter, remove all ash accumulation (the chimney connector can also be removed to allow access to the manifold for cleaning).

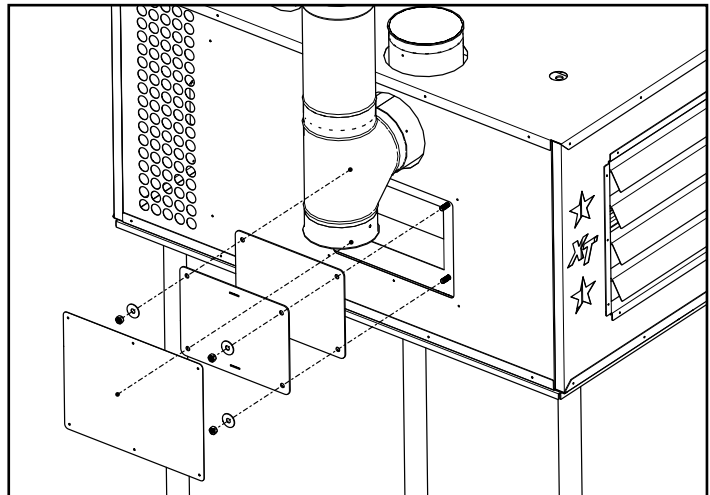

14. Inspect and clean the chimney connector if necessary.
15. Replace all gaskets that were removed during the cleaning process. **Do not reuse gaskets.**
16. Re-secure the access panel and port cover to the heater with the fasteners removed in previous steps, respectively.
17. Reconnect all power at the main breaker box, wait ten minutes before turning the thermostat up. Your heater is now ready for normal operation.

NOTE: When changing the target brick, call the Lanair Service Department for assistance.

⚠ WARNING



WARNING: DO NOT OPERATE YOUR FURNACE WITH CLEAN OUT PANELS OR PORTS REMOVED

QUESTIONS?... Contact Customer Service at 1-888-370-6531 M-F 8:00 am- 4:15 pm CST

Section 13 - Troubleshooting

Initial Diagnosis:

When an operating problem occurs, a determination must be made whether or not the fuel pump is pumping a sufficient amount of oil that contains no air or water.

Take these steps:

- Turn the thermostat off or to a temperature below room temperature
- Disconnect the fuel supply line from the burner.
- Insert the fuel line into the bottom of a large jar.
- Toggle the priming switch from the "RUN" position to the "PRIME" position
- Attempt to fill the container, keeping the fuel line above the tank's fuel level.
- A steady stream of oil should flow from the fuel line
- If the pump will not pump fuel, attempt to prime the pump (Section 9). If the pump won't prime refer to troubleshooting chart symptom B.

When using the optional metering pump:

Pump fuel into a graduated container. The flow rate will vary by model.

XT-150	1.1 gal/hr (69 ml/min)
XT(D)-200	1.4 gal/hr (88 ml/min)
XT-250	1.8 gal/hr (113 ml/min)
XT(D)-300	2.1 gal/hr (132 ml/min)

If flow rate using a metering pump is incorrect by more than +/- 10%, contact Lanair Service at 888-370-6531.

After repairs are made, toggle the priming switch from the "PRIME" position to the "RUN" position, reconnect the fuel-supply line to the burner, and reset the thermostat.

▲ WARNING



WARNING: DO NOT OPERATE YOUR HEATER IF THE OIL PRIMARY SAFETY CIRCUIT IS NOT WORKING!

Visit our website at: www.lanair.com

Burner fuel pressure gauge reading hints:

Fuel gauge fluctuates (jumps):

- Leak in suction line plumbing.
- Water/Anti-freeze in fuel.
- Air in fuel, refer to troubleshooting chart symptom B.
- Quad ring seal for the nozzle may be damaged.
- Seal in adapter block may be worn or damaged.
- Fuel pressure regulator seal leaking or dirty when using a bypass regulator.
- Suction line strainer plugged or dirty.

Reading gradually decreases:

- Fuel pump output decreasing.
- Fuel viscosity decreasing.
- Orifice in nozzle is wearing.

Reading gradually increases:

- Fuel pump output increasing.
- Fuel viscosity increasing (cold fuel, and/or gear lube).
- Orifice in nozzle is becoming plugged.

Reading drops to -0- PSI when the burner is off.

- Dirt between the diaphragm and the seat in the bypass regulator when using a bypass regulator.
- Dirt between the plunger and the nozzle seat.
- Leak in the plumbing connections.
- Leak in the preheater assembly (damaged or missing o-ring).
- Fuel preheater switch is off.



Section 13 - Troubleshooting

Symptom	Possible Cause	Corrective Action
A. Burner will not start	1. Main electrical-power circuit breaker tripped	1. Reset breaker
	2. Service disconnect switch off or fuse blown	2. Turn switch on or replace fuse
	3. Thermostat turned down/improperly installed/defective	3. Turn thermostat up/check wires/test components/replace
	4. Oil primary controller tripped/defective	4. Reset/test components, replace if needed
	5. Too much light showing on flame sensor/sensor defective	5. Eliminate light exposure at flame sensor
B. Burner attempts to fire but does not establish a flame	1. Low fuel supply or contaminated fuel	1. Fill tank
	2. Clogged or worn nozzle	2. Clean or replace
	3. Fuel-pressure gauge fluctuating/pumping system	3. Check pump fittings/priming/vacuum leak; purge air from supply lines
	4. Preheater switch is turned off/defective or cartridge heater is defective	4. Move switch to "ON" position, test switch and cartridge heater
	5. Transformer/electrodes not sparking	5. Test transformer, look for short-circuit contact(s) and reposition, if necessary; replace components if needed
	6. No air pressure/defective regulator/defective solenoid	6. Confirm compressor is ON, test regulator/solenoid; replace defective components
	7. Water in air system	7. Clean air preheater and purge water from air system
	8. Combustion blower not properly adjusted/defective	8. Adjust flame (Section 11); replace blower if necessary
	9. Improper draft	9. Ensure chimney is properly installed; adjust barometric damper
	10. Clogged heat exchanger or chimney	10. Clean heater, including upper manifold and chimney

QUESTIONS?... Contact Customer Service at 1-888-370-6531 M-F 8:00 am- 4:15 pm CST

Section 13 - Troubleshooting

Symptom	Possible Cause	Corrective Action
C. Burner fires but then trips primary control	1. Contaminated fuel supply (water/antifreeze/gear lube), dirty fuel filter	1. Drain and clean fuel-supply tank; clean fuel filter
	2. Improper draft	2. Ensure chimney is installed properly and draft is set
	3. Clogged heat exchanger or chimney	3. Clean heater, including upper manifold and chimney
	4. Incorrect air pressure	4. Adjust flame settings (Section 11)
	5. Incorrect fuel pressure	5. Check fuel supply (Section 6) and flame adjustment (Section 11)
	6. Improper combustion air baffle setting/combustion blower is defective	6. Adjust flame (Section 11); test combustion blower motor, replace if necessary
	7. Oil primary control/flame sensor defective, flame sensor and/or turbulator improperly adjusted/dirty	7. Clean/test/adjust components; replace if necessary
	8. Clogged nozzle and/or preheater assembly	8. Clean/replace nozzle and/or preheater assembly
D. Preheater assembly not working	1. Cartridge heater(s) defective/disconnected	1. Test cartridge heater(s) using an Ohm meter: Air heater = $112 \Omega \pm 10\%$ Oil heater = $37 \Omega \pm 10\%$
	2. Snap disc defective	2. Test snap disc for continuity when preheater is cold



Return Guidelines

1. All returned merchandise must be unused and returned in the same new condition in which it was originally received, with all accompanying original packaging. Any items returned used, damaged in any way or with missing components will not be refunded. Return merchandise must be shipped freight prepaid.
2. All returns must be authorized by the Lanair Customer Service Department. Unauthorized returns will NOT be accepted or refunded, and may be refused when received.
3. Authorized returns for merchandise in original boxes and in new condition are subject to a 20% restocking charge. No returns are accepted on custom or special order items. Electrical components may be subject to inspection.
4. All returns must be made within fifteen (15) days after the date of the shipment for orders within the United States. For foreign orders, the return must be made within sixty (60) days of the initial shipment.
5. All authorized returns will be fully refunded less restocking fees, shipping and handling charges.
6. To obtain an authorization number, please call our customer service department at **1-888-370-6531**, or email us at **service@lanair.com**
7. All authorized returns must have the authorization number marked on the outside of the package and returned to the following address:

**Lanair Products LLC
Returns Department
4109 Capital Circle Drive
Janesville, WI 53546**

Warranty Conditions

Lanair Products LLC (Manufacturer) warrants to the original purchaser of this used oil heater, that it will repair or replace at Lanair Products LLC's option, any part which is in normal use proves to be defective in material or workmanship within a period of one year from the date of purchase, provided same is returned (transportation pre-paid) F.O.B. Janesville Wisconsin, for Lanair Products LLC's inspection and warranty determination. Normal wear and tear items are not covered. Lanair Products does not warrant paint finish. The warranty does not cover labor charges involved with part replacement or service unless pre-authorized in writing. Lanair Products LLC may also require photographs of the heater installation for warranty determination.

LANAIR 10 YEAR WASTE OIL HEATER COMBUSTION CHAMBER AND HEAT EXCHANGER LIMITED WARRANTY

Lanair Products LLC, MANUFACTURER, hereby warrants that any part of manufacturer's product shall be free from defect in material and workmanship under normal use according to the provisions and limitations herein set forth for a period of one (1) year provided same is returned (pre-paid) F.O.B. Janesville, Wisc. for inspection and warranty determination.

MANUFACTURER warrants the heat exchanger/combustion chamber for three (3) years from the date of purchase and pro rata thereafter according to the following schedule: If a defect occurs during the first three years, MANUFACTURER will repair or replace the combustion chamber/heat exchanger FREE of charge. If a defect occurs in years four through ten (4-10) MANUFACTURER will repair or replace your combustion chamber/heat exchanger. Your guaranteed replacement cost will be shared by MANUFACTURER 50/50.*

***IMPORTANT:** Combustion chamber / heat exchanger must be maintained in accordance with the installation / operating instructions. This extended warranty does not cover normal wear items such as gasket material, chamber inserts, nuts, bolts, labor costs, etc. The warranty card must be returned within ten (10) days of purchase date in order for this warranty to be valid. Warranty is limited to original purchaser.*

**MANUFACTURER'S determination regarding repair or replacement is final.
Cost of freight is owner's responsibility.*

Model Number: XT Series Heater

Date Purchased: _____

Conditions That Will Void Warranty

- Use of liquids such as: solvents, brake fluid, gasoline, K-1, kerosene, paint thinners, gear lube, transformer oil, cutting oils, anti-freeze, water or any other liquid not approved for use.
- Tampering with internal components
- Failure to inspect and clean combustion chamber/heat exchanger at the end of each heating season.
- Continuous over-firing of the unit
- Heater has not been installed or serviced in accordance to the installation / operating manual.
- Alteration or misuse of any part
- Use of parts other than those supplied by Lanair.

NOTE: Lanair may require photographs of the heater installation for warranty determination

NOTE: Re-stocking fee of 20% applies on all returned parts

Items Not Covered Under Warranty

- Any portion of the combustion chamber/heat exchanger if:
 - The unit is not installed per the owners manual.
 - The yearly inspection requirements are not current.
 - If the heater is used for a purpose for which it is not intended.
 - If the heater is not operated in accordance with the printed instructions in the
 - If any alterations or unauthorized repairs are made to the unit.
- Damage incurred from abuse, neglect, shipping, natural acts, misuse or accident.
- Labor costs for service calls for any reason including:
 - Cleaning or performing required maintenance.
 - Installation corrections
 - Any parts installation.
- Parts that are replaced because of normal wear and tear.
- Goods purchased under this agreement shall be used exclusively by the buyer and no other person or third party shall benefit from the express or implied warranties contained in the agreement



Lanair Products LLC
4109 Capital Circle
Janesville, Wisconsin 53546
1-888-370-6531
www.lanair.com