



# Firepower® FP 125, FP 135, FP165 PORTABLE MIG/FLUX CORED WELDER

## Operating Manual



Révision : AC

Issue Date: April 6, 2016

Manual No.: 0-5123

[www.firepoweronline.com](http://www.firepoweronline.com)



## **WE APPRECIATE YOUR BUSINESS!**

Congratulations on your new Firepower product. We are proud to have you as our customer and will strive to provide you with the best service and reliability in the industry. This product is backed by our extensive warranty and world-wide service network. To locate your nearest distributor or service agency, visit us on the web at [www.firepoweronline.com](http://www.firepoweronline.com).

This Operating Manual has been designed to instruct you on the correct use and operation of your Firepower product. Your satisfaction with this product and its safe operation is our ultimate concern. Therefore please take the time to read the entire manual, especially the Safety Precautions. They will help you to avoid potential hazards that may exist when working with this product.

## **YOU ARE IN GOOD COMPANY!**

**The Brand of Choice for Contractors and Fabricators Worldwide.**

ESAB is a Global Brand of manual and automation Plasma Cutting Products.

We distinguish ourselves from our competition through market-leading, dependable products that have stood the test of time. We pride ourselves on technical innovation, competitive prices, excellent delivery, superior customer service and technical support, together with excellence in sales and marketing expertise.

Above all, we are committed to developing technologically advanced products to achieve a safer working environment within the welding industry.



**WARNING**

Read and understand this entire Manual and your employer's safety practices before installing, operating, or servicing the equipment.

While the information contained in this Manual represents the Manufacturer's best judgement, the Manufacturer assumes no liability for its use.

Firepower FP 125, 135, 165 MIG/Flux Cored Welder  
Operating Manual Number 0-5123

Published by:  
ESAB  
2800 Airport Rd.  
Denton, TX 76208

[www.Firepoweronline.com](http://www.Firepoweronline.com)

Copyright 2015 by ESAB

All rights reserved.

Reproduction of this work, in whole or in part, without written permission of the publisher is prohibited.

The publisher does not assume and hereby disclaims any liability to any party for any loss or damage caused by any error or omission in this Manual, whether such error results from negligence, accident, or any other cause.

For Printing Material Specification refer to document 47x1909  
Original Publication Date: March 19, 2009  
Revision Date: April 6, 2016

Record the following information for Warranty purposes:

Where Purchased: \_\_\_\_\_

Purchase Date: \_\_\_\_\_

Power Supply Serial #: \_\_\_\_\_

Torch Serial #: \_\_\_\_\_

**Be sure this information reaches the operator.  
You can get extra copies through your supplier.**

## **CAUTION**

**These INSTRUCTIONS are for experienced operators. If you are not fully familiar with the principles of operation and safe practices for arc welding and cutting equipment, we urge you to read our booklet, "Precautions and Safe Practices for Arc Welding, Cutting, and Gouging," Form 52-529. Do NOT permit untrained persons to install, operate, or maintain this equipment. Do NOT attempt to install or operate this equipment until you have read and fully understand these instructions. If you do not fully understand these instructions, contact your supplier for further information. Be sure to read the Safety Precautions before installing or operating this equipment.**

### **USER RESPONSIBILITY**

This equipment will perform in conformity with the description thereof contained in this manual and accompanying labels and/or inserts when installed, operated, maintained and repaired in accordance with the instructions provided. This equipment must be checked periodically. Malfunctioning or poorly maintained equipment should not be used. Parts that are broken, missing, worn, distorted or contaminated should be replaced immediately. Should such repair or replacement become necessary, the manufacturer recommends that a telephone or written request for service advice be made to the Authorized Distributor from whom it was purchased.

This equipment or any of its parts should not be altered without the prior written approval of the manufacturer. The user of this equipment shall have the sole responsibility for any malfunction which results from improper use, faulty maintenance, damage, improper repair or alteration by anyone other than the manufacturer or a service facility designated by the manufacturer.

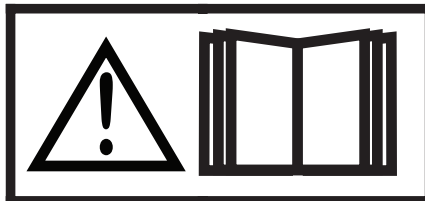

**READ AND UNDERSTAND THE INSTRUCTION MANUAL BEFORE INSTALLING OR  
OPERATING.  
PROTECT YOURSELF AND OTHERS!**

## TABLE OF CONTENTS

<b>SECTION 1: SAFETY</b> .....	<b>1-1</b>
1.0 Safety Precautions .....	1-1
2.0 Précautions de sécurité .....	1-3
<b>SECTION 2:</b>	
<b>INTRODUCTION</b> .....	<b>2-1</b>
2.01 How To Use This Manual .....	2-1
2.02 Equipment Identification .....	2-1
2.03 Receipt Of Equipment .....	2-1
2.04 General .....	2-1
2.05 Specifications .....	2-2
2.06 Volt - Amp Curves .....	2-3
2.07 Duty Cycle .....	2-5
2.08 MIG Gun Maintenance .....	2-6
2.09 Handle / Feet Assembly.....	2-6
<b>SECTION 3:</b>	
<b>INSTALLATION</b> .....	<b>3-1</b>
3.01 Location .....	3-1
3.02 Safety .....	3-1
3.03 Grounding .....	3-1
3.04 Electrical Input Requirements .....	3-1
3.05 Requirements for Maximum Output .....	3-1
3.06 Installation of Shielding Gas (GMAW) Process .....	3-2
3.07 Attaching the Gun and Cable Assembly to the Power Source .....	3-5
3.08 Polarity Changeover .....	3-6
3.09 Installing Wire Spool .....	3-7
3.10 Feedrolls .....	3-7
3.11 Install Wire into the Feedhead .....	3-7
3.12 Install Wire into the Welding Gun .....	3-9
<b>SECTION 4:</b>	
<b>OPERATION</b> .....	<b>4-1</b>
4.01 General Safety Precautions .....	4-1
4.02 Firepower Controls .....	4-1
4.03 Gas Metal Arc Welding (GMAW) .....	4-3
4.04 Flux Cored Arc Welding (FCAW) .....	4-3
4.05 Shutdown Procedures .....	4-3
4.06 Basic Welding Technique .....	4-3
4.07 Welding Gun Positions .....	4-5
4.08 MIG Welding (GMAW) Variables .....	4-6
4.09 Establishing the Arc and Making Weld Beads .....	4-7
4.10 Pre-Weld Procedure .....	4-7
4.11 Welding Procedure .....	4-7
4.12 Reference Tables .....	4-8
4.13 Firepower FP 125 Welding Setting Selection Guide .....	4-9
4.14 Firepower FP 135 Welding Setting Selection Guide .....	4-10

## TABLE OF CONTENTS

4.15	Firepower FP 165 Welding Setting Selection Guide .....	4-11
4.16	Gas Selection for Gas Metal Arc Welding.....	4-12
<b>SECTION 5:</b>		
	<b>SERVICE.....</b>	<b>5-1</b>
5.01	Cleaning of the Unit .....	5-1
5.02	Cleaning of the Feed Rolls .....	5-1
5.03	Basic Troubleshooting .....	5-1
5.04	Solving Problems Beyond the Welding Terminals .....	5-1
5.05	Welding Problems .....	5-2
<b>APPENDIX 1: OPTIONS AND ACCESSORIES.....</b>		<b>A-1</b>
<b>APPENDIX 2: REPLACEMENT PARTS .....</b>		<b>A-2</b>
<b>APPENDIX 3: FIREPOWER 125 SYSTEM SCHEMATIC.....</b>		<b>A-4</b>
<b>APPENDIX 4: FIREPOWER 135 SYSTEM SCHEMATIC.....</b>		<b>A-5</b>
<b>APPENDIX 5: FIREPOWER 165 SYSTEM SCHEMATIC.....</b>		<b>A-6</b>
<b>REVISION HISTORY .....</b>		<b>A-8</b>
<b>INTERNATIONAL CONTACT INFORMATION .....</b>		<b>REAR COVER</b>

## SECTION 1: SAFETY

### 1.0 Safety Precautions

Users of ESAB welding and plasma cutting equipment have the ultimate responsibility for ensuring that anyone who works on or near the equipment observes all the relevant safety precautions. Safety precautions must meet the requirements that apply to this type of welding or plasma cutting equipment. The following recommendations should be observed in addition to the standard regulations that apply to the workplace.

All work must be carried out by trained personnel well acquainted with the operation of the welding or plasma cutting equipment. Incorrect operation of the equipment may lead to hazardous situations which can result in injury to the operator and damage to the equipment.

1. Anyone who uses welding or plasma cutting equipment must be familiar with:
  - its operation
  - location of emergency stops
  - its function
  - relevant safety precautions
  - welding and / or plasma cutting
2. The operator must ensure that:
  - no unauthorized person stationed within the working area of the equipment when it is started up.
  - no one is unprotected when the arc is struck.
3. The workplace must:
  - be suitable for the purpose
  - be free from drafts
4. Personal safety equipment:
  - Always wear recommended personal safety equipment, such as safety glasses, flame proof clothing, safety gloves.
  - Do not wear loose fitting items, such as scarves, bracelets, rings, etc., which could become trapped or cause burns.
5. General precautions:
  - Make sure the return cable is connected securely.
  - Work on high voltage equipment **may only be carried out by a qualified electrician.**
  - Appropriate fire extinguishing equipment must be clearly marked and close at hand.
  - Lubrication and maintenance **must not** be carried out on the equipment during operation.



#### **Dispose of electronic equipment at the recycling facility!**

In observance of European Directive 2002/96/EC on Waste Electrical and Electronic Equipment and its implementation in accordance with national law, electrical and/or electronic equipment that has reached the end of its life must be disposed of at a recycling facility.

As the person responsible for the equipment, it is your responsibility to obtain information on approved collection stations.

For further information contact the nearest ESAB dealer.

ESAB can provide you with all necessary cutting protection and accessories.

# FIREPOWER FP 125,135,165

## WARNING

Arc welding and cutting can be injurious to yourself and others. Take precautions when welding and cutting. Ask for your employer's safety practices which should be based on manufacturers' hazard data.

### ELECTRIC SHOCK - Can kill.

- Install and earth (ground) the welding or plasma cutting unit in accordance with applicable standards.
- Do not touch live electrical parts or electrodes with bare skin, wet gloves or wet clothing.
- Insulate yourself from earth and the workpiece.
- Ensure your working stance is safe.

### FUMES AND GASES - Can be dangerous to health.

- Keep your head out of the fumes.
- Use ventilation, extraction at the arc, or both, to take fumes and gases away from your breathing zone and the general area.

### ARC RAYS - Can injure eyes and burn skin.

- Protect your eyes and body. Use the correct welding / plasma cutting screen and filter lens and wear protective clothing.
- Protect bystanders with suitable screens or curtains.

### FIRE HAZARD

- Sparks (spatter) can cause fire. Make sure therefore that there are no inflammable materials nearby.

### NOISE - Excessive noise can damage hearing.

- Protect your ears. Use earmuffs or other hearing protection.
- Warn bystanders of the risk.

### MALFUNCTION - Call for expert assistance in the event of malfunction.

**READ AND UNDERSTAND THE INSTRUCTION MANUAL BEFORE INSTALLING OR OPERATING.**

**PROTECT YOURSELF AND OTHERS!**

## WARNING

Do not use the power source for thawing frozen pipes.

## CAUTION

Class A equipment is not intended for use in residential locations where the electrical power is provided by the public low-voltage supply system. There may be potential difficulties in ensuring electromagnetic compatibility of class A equipment in those locations, due to conducted as well as radiated disturbances.



## CAUTION

This product is solely intended for metal removal. Any other use may result in personal injury and / or equipment damage.

## CAUTION

Read and understand the instruction manual before installing or operating.

**CUIDADO**

## 2.0 Précautions de sécurité

Les utilisateurs du matériel de soudage et de coupage plasma ESAB ont la responsabilité ultime d'assurer que toute personne qui opère ou qui se trouve dans l'aire de travail observe les précautions de sécurité pertinentes. Les précautions de sécurité doivent répondre aux exigences applicables à ce type de matériel de soudage ou de coupage plasma. Les recommandations suivantes doivent être observées en plus des règles standard qui s'appliquent au lieu de travail.

Tous les travaux doivent être effectués par un personnel qualifié possédant de bonnes connaissances par rapport au fonctionnement du matériel de soudage et de coupage plasma. Un fonctionnement incorrect du matériel peut produire des situations dangereuses qui peuvent causer des blessures à l'opérateur ou des dommages au matériel.

1. Toute personne travaillant avec le matériel de soudage ou de coupage plasma doit connaître :
  - son fonctionnement;
  - l'emplacement des interrupteurs d'arrêt d'urgence;
  - sa fonction;
  - les précautions de sécurité pertinentes;
  - les procédures de soudage et/ou de coupage plasma.
  
2. L'opérateur doit assurer que :
  - seules les personnes autorisées à travailler sur l'équipement se trouvent dans l'aire de travail lors de la mise en marche de l'équipement;
  - toutes les personnes dans l'aire de travail sont protégées lorsque l'arc est amorcé.
  
3. Le lieu de travail doit être :
  - aménagé convenablement pour acquérir le matériel en toute sécurité;
  - libre de courants d'air.
  
4. Équipement de sécurité personnelle
  - Vous devez toujours utiliser un équipement de sécurité convenable tels que les lunettes de protection, les vêtements ininflammables et des gants de protection.
  - Vous ne devez jamais porter de vêtements amples, tels que foulards, bracelets, bagues, etc., qui pourraient se prendre dans l'appareil ou causer des brûlures.
  
5. Précautions générales :
  - Assurez-vous que le câble de retour est bien branché.
  - La réparation d'un équipement de haute tension **doit être effectuée par un électricien qualifié seulement**.
  - Un équipement d'extinction d'incendie approprié doit être à proximité de l'appareil et l'emplacement doit être clairement indiqué.
  - Vous **ne devez jamais** procéder à la lubrification ou l'entretien du matériel lorsque l'appareil est en marche.

### Classe de boîtier

Le code IP indique la classe du boîtier, à savoir le niveau de protection offert contre toute pénétration par des objets solides ou de l'eau. La protection est fournie contre le contact d'un doigt, la pénétration d'objets solides d'une taille supérieure à 12 mm et contre l'eau pulvérisée jusqu'à 60 degrés de la verticale. L'équipement marqué **IP21S** peut être stocké mais ne doit pas être utilisé à l'extérieur quand il pleut à moins d'être sous abri.

## ATTENTION

**Si l'équipement est placé sur une surface inclinée de plus de 15°, il y a danger de basculement et en conséquence, des blessures personnelles et/ou des dommages importants à l'équipement.**

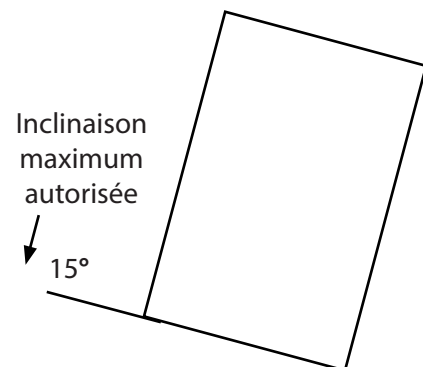

## AVERTISSEMENT

**LE SOUDAGE ET LE COUPAGE À L'ARC PEUVENT CAUSER DES BLESSURES À L'OPÉRATEUR OU LES AUTRES PERSONNES SE TROUVANT DANS L'AIRE DE TRAVAIL. ASSUREZ-VOUS DE PRENDRE TOUTES LES PRÉCAUTIONS NÉCESSAIRES LORS D'UNE OPÉRATION DE SOUDAGE OU DE COUPAGE. DEMANDEZ À VOTRE EMPLOYEUR UNE COPIE DES MESURES DE SÉCURITÉ QUI DOIVENT ÊTRE ÉLABORÉES À PARTIR DES DONNÉES DES RISQUE DU FABRICANT.**

**CHOC ÉLECTRIQUE** - peut être mortel.

- Assurez-vous que l'unité de soudage ou de coupage plasma est installée et mise à la terre conformément aux normes applicables.
- Ne touchez pas aux pièces électriques sous tension ou les électrodes si vos mains ne sont pas bien protégées ou si vos gants ou vos vêtements sont humides.
- Assurez-vous que votre corps est bien isolé de la mise à la terre et de la pièce à traiter.
- Assurez-vous que votre position de travail est sécurisée.

**VAPEURS ET GAZ** - peuvent être dangereux pour la santé.

- Gardez votre tête éloignée des vapeurs.
- Utilisez un système de ventilation et/ou d'extraction à l'arc pour évacuer les vapeurs et les gaz de votre zone respiratoire.

**RAYONS DE L'ARC** - peuvent endommager la vue ou brûler la peau.

- Protégez vos yeux et votre corps. Utilisez un écran de soudage/coupage plasma convenable équipé de lentilles teintées et portez des vêtements de protection.
- Protégez les personnes se trouvant dans l'aire de travail à l'aide d'un écran ou d'un rideau protecteur convenable.

**RISQUE D'INCENDIE**

- Les étincelles (projections) peuvent causer un incendie. Assurez-vous qu'il n'y a pas de matériel inflammable à proximité de l'appareil.

**BRUIT** - un bruit excessif peut endommager la capacité auditive.

- Protégez vos oreilles. Utilisez des protecteurs d'oreilles ou un autre type de protection auditive.
- Avertissez les personnes se trouvant dans l'aire de travail de ce risque.

**FONCTIONNEMENT DÉFECTUEUX** - Dans le cas d'un fonctionnement défectueux demandez l'aide d'une personne qualifiée.

**ASSUREZ-VOUS DE LIRE ET DE COMPRENDRE LE MANUEL D'UTILISATION AVANT D'INSTALLER OU D'OPÉRER L'UNITÉ. PROTÉGEZ-VOUS ET LES AUTRES !**

## ATTENTION

**Ce produit est uniquement destiné à la découpe du plasma. Toute autre utilisation peut entraîner des blessures ou endommager l'équipement.**

## ATTENTION

**Pour éviter toute blessure personnelle et/ou endommagement à l'équipement, soulever à l'aide de la méthode et des points d'attache indiqués ici.**

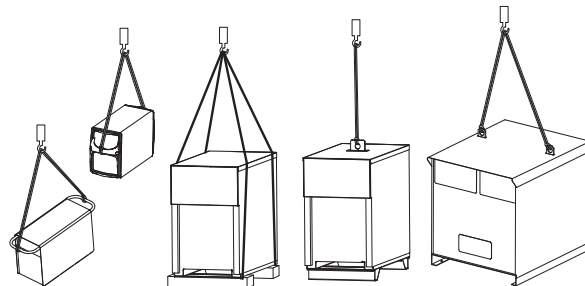

## SECTION 2: INTRODUCTION

### 2.01 How To Use This Manual

This Owner's Manual applies to just specification or part numbers listed on page i.

To ensure safe operation, read the entire manual, including the chapter on safety instructions and warnings.

Throughout this manual, the words WARNING, CAUTION, DANGER, and NOTE may appear. Pay particular attention to the information provided under these headings. These special annotations are easily recognized as follows:



**NOTE!**

An operation, procedure, or background information which requires additional emphasis or is helpful in efficient operation of the system.



**CAUTION**

A procedure which, if not properly followed, may cause damage to the equipment.



**WARNING**

A procedure which, if not properly followed, may cause injury to the operator or others in the operating area.



**WARNING**

Gives information regarding possible electrical shock injury. Warnings will be enclosed in a box such as this.



**DANGER**

Means immediate hazards which, if not avoided, will result in immediate, serious personal injury or loss of life.

Additional copies of this manual may be purchased by contacting ESAB at the address and phone number in your area listed on back cover of this manual. Include the Owner's Manual number and equipment identification numbers.

Electronic copies of this manual can also be downloaded at no charge in Acrobat PDF format by going to the Firepower web site listed below

<http://www.firepoweronline.com>

### 2.02 Equipment Identification

The unit's identification number (specification or part number), model, and serial number usually appear on a data tag attached to the rear panel. Equipment which does not have a data tag such as torch and cable assemblies are identified only by the specification or part number printed on loosely attached card or the shipping container. Record these numbers on the bottom of page i for future reference.

### 2.03 Receipt Of Equipment

When you receive the equipment, check it against the invoice to make sure it is complete and inspect the equipment for possible damage due to shipping. If there is any damage, notify the carrier immediately to file a claim. Furnish complete information concerning damage claims or shipping errors to the location in your area listed in the inside back cover of this manual.

Include all equipment identification numbers as described above along with a full description of the parts in error.

Move the equipment to the installation site before un-crating the unit. Use care to avoid damaging the equipment when using bars, hammers, etc., to un-crate the unit.

### 2.04 General

The Firepower FP 125, 135, 165 Machines are single-phase input welding machines and come equipped with the following:

1. Built-in Wire Feeder and Wire Spool Hub
2. Welding Gun and Cable
3. Work Cable and Clamp
4. Regulator/Flow Meter (FP 125 optional)
5. Input Cord
6. 2 Spare Contact Tips
7. Operational Manual
8. 0.5 lb. Spool of Wire
9. Gas Hose

The welding system is designed for use with the following processes:

1. GMAW - Gas metal arc welding (MIG). Requires the use of a shielding gas and regulator.
2. FCAW – Flux-cored arc welding – Does not require the use of a shielding gas.

# FIREPOWER FP 125,135,165

## 2.05 Specifications

Description	FP 125	FP 135	FP 165
Package System Part Number	1444-0324	1444-0326	1444-0328
Power Source Weight	47.4 lb (21.5 kg)	52.9 lb (24.0kg)	58.1 lb (26.4 kg)
Power Source Dimensions HxWxD	12 x 9.75 x 17.5" ( 304.8 x 247.7 x 444.5mm)		
Number of Phases	1 Ø		
Frequency	60Hz		
Flexible Supply Cable Size	7 ft (2.2 m) 14AWG	7 ft (2.2 m) 14AWG	7.5 ft (2.5 m) 14AWG
Supply Lead Plug Type	5-15P	5-15P	6-50P
Nominal Input Voltage	120V AC	120V AC	230V AC
Rated kVA @ 100% Duty Cycle	5kVA	6kVA	7kVA
Rated Input Current	15A (60A@40%)	15A (60A@60%)	22.5A (120A@25%)
Maximum Input Current	38A (110A@10%)	50A (120A@13%)	35A (155A@15%)
Generator Requirements	# 5kVA	# 6kVA	# 7kVA
Supply VA @ max. output	# 4.6kVA	# 5kVA	# 6.8kVA
Open Circuit Voltage Range	16 – 30V	16 – 32V	15 – 30V
Output Current Range	40 – 125A	39 – 135A	36 – 165A
Duty Cycle Period	10 Minutes		
Number of Output Voltage Values	4		
Minimum Mains Circuit to suit factory fitted Plug & Lead (Weld Current @ Duty Cycle)	15A (60A@40%)	15A (60A@60%)	22.5A (120A@25%)
Maximum Mains Circuit to suit factory fitted Plug & Lead (Weld Current @ Duty Cycle)	38A (110A@10%)	50A (120A@13%)	35A (155A@15%)
Wire Size Range			
Steel	.023" - .030" - .035" (0.6 - 0.8 - 0.9mm)		
Stainless Steel	.023" - .030" - .035" (0.6 - 0.8 - 0.9mm)		.023" - .030" - .035" (0.6 - 0.8 - 0.9mm)
Flux Core	.030" - .035" (0.8 - 0.9mm)	.030" - .035" (0.8 - 0.9mm)	.030" - .035" (0.8 - 0.9mm)

Table 2-1: System Specifications

Δ The recommended time delay fuse or circuit breaker size is 20 amp. An individual branch circuit capable of carrying 30 amperes and protected by fuses or circuit breaker is recommended for this application. Fuse size is based on not more than 200 percent of the rated input amperage of the welding power source (Based on Article 630, National Electrical Code)

Firepower continuously strives to produce the best product possible and therefore reserves the right to change, improve or revise the specifications or design of this or any product without prior notice. Such updates or changes do not entitle the buyer of equipment previously sold or shipped to the corresponding changes, updates, improvements or replacement of such items.

The values specified in the table above are optimal values, your values may differ. Individual equipment may differ from the above specifications due to in part, but not exclusively, to any one or more of the following; variations or changes in manufactured components, installation location and conditions and local power grid supply conditions.

**2.06 Volt - Amp Curves**

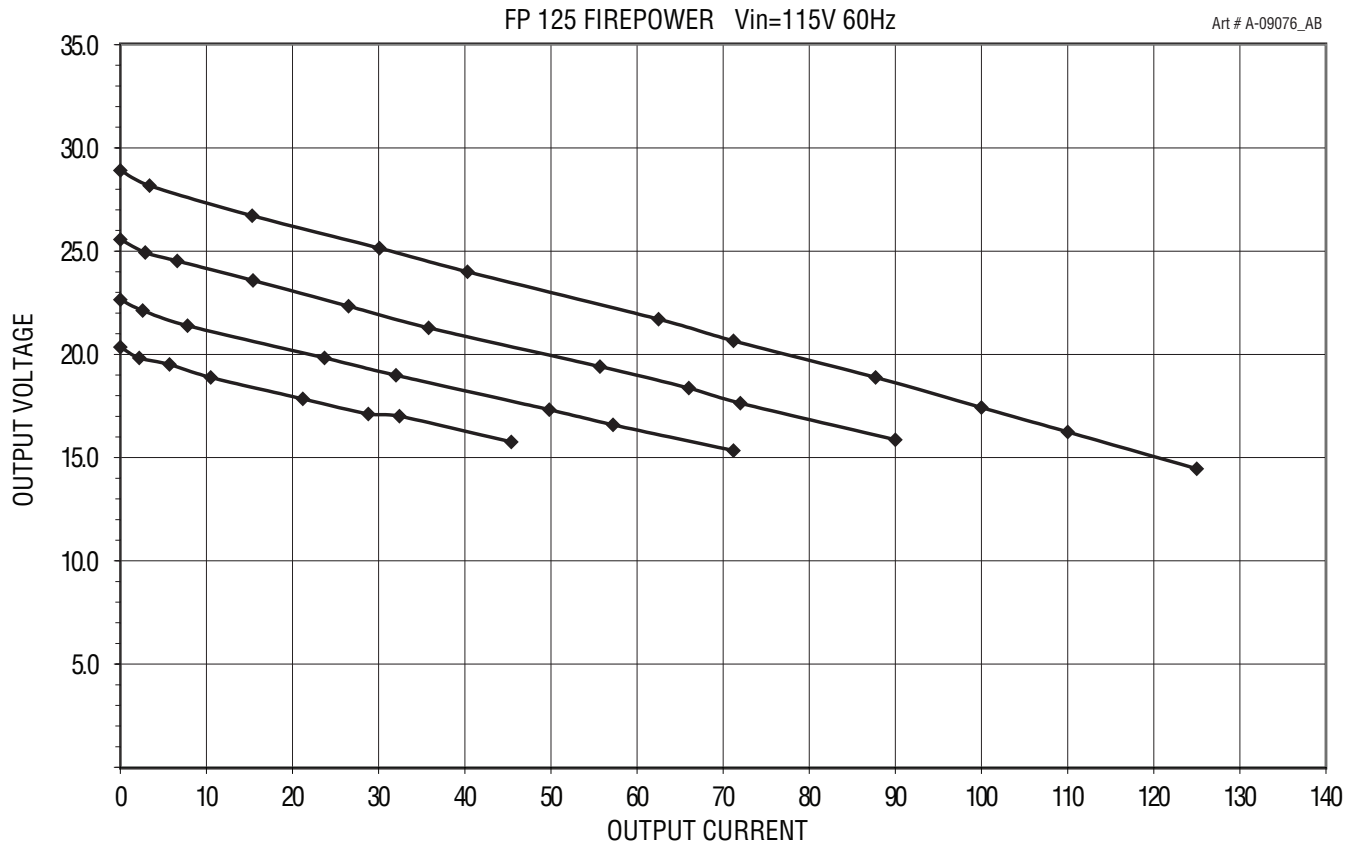

Figure 2-1: Volt/Amp curves of the Firepower 125

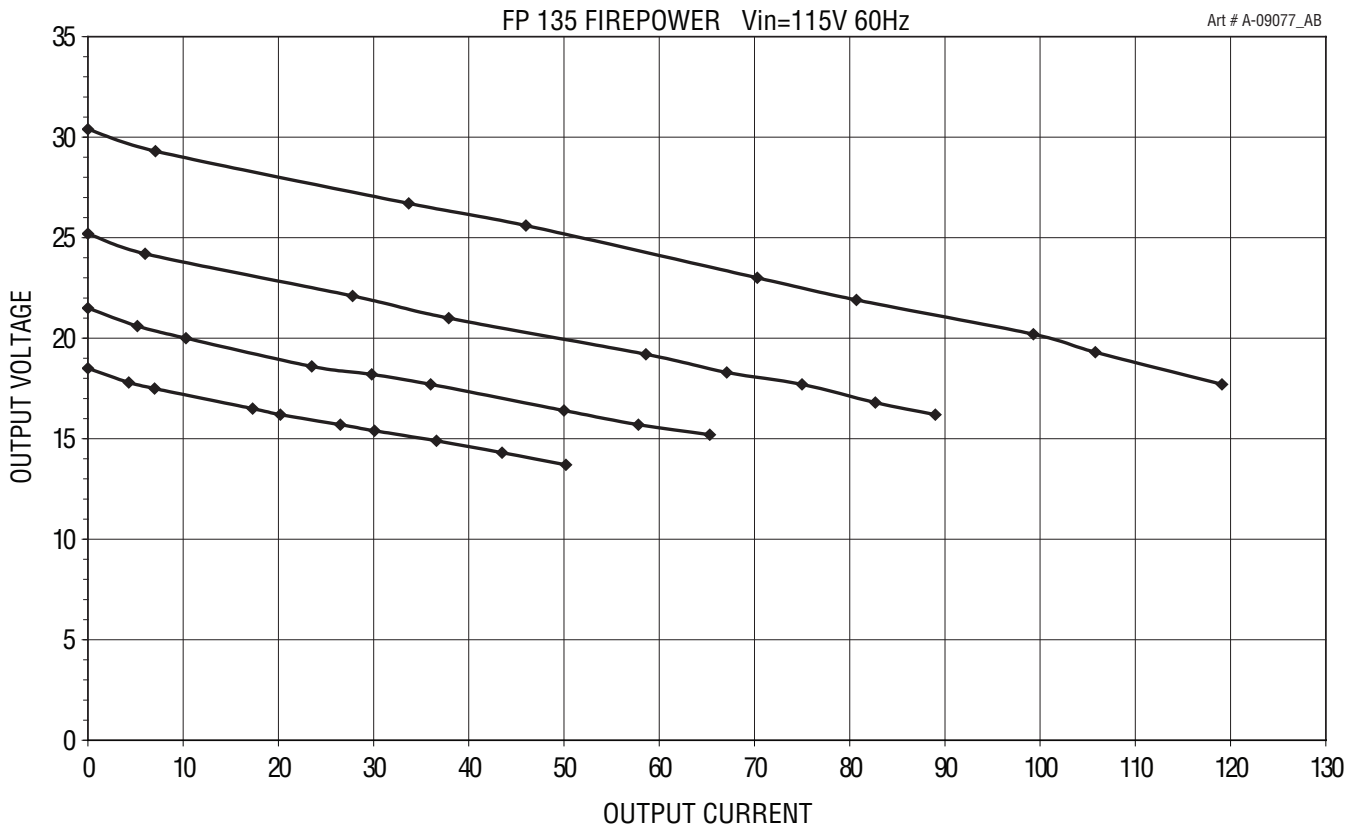

Figure 2-1: Volt/Amp curves of the Firepower 135

# FIREPOWER FP 125,135,165

FP 165 FIREPOWER Vin=230V 60Hz

Art # A-09078\_AB

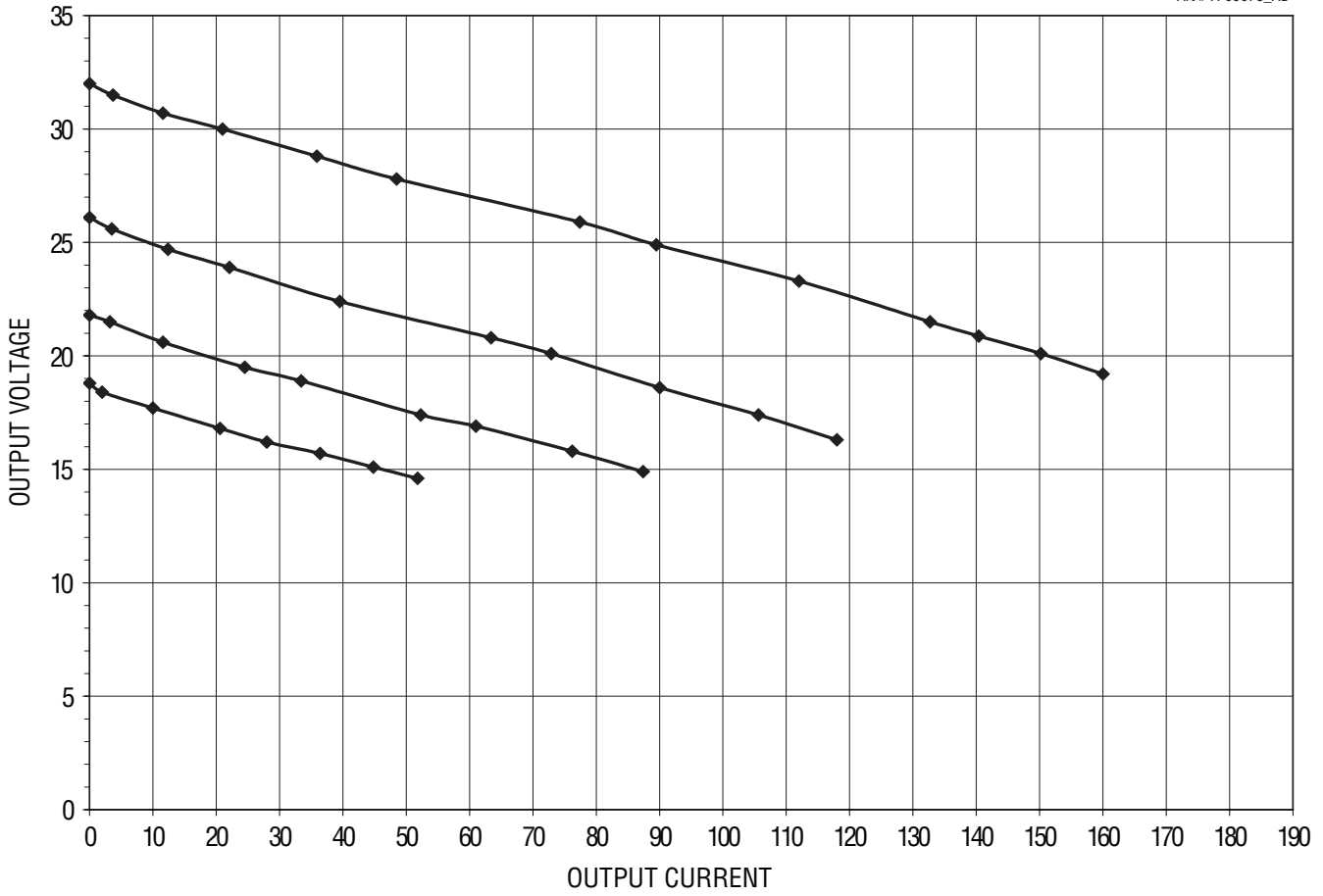

Figure 2-1: Volt/Amp curves of the Firepower 165

**2.07 Duty Cycle**

Duty Cycle is the amount of arc-on time (actual welding time) during any 10 minute period that a machine can operate at it's rated output without damaging internal components. For example, the Firepower FP 135 is designed for 20% duty cycle at 117 amps. This means that it has been designed and built to provide the rated amperage, 117 amps, for 2 minutes out of every 10 minute period. During the other 8 minutes of the 10 minute period, the Firepower FP 135 must idle and be allowed to cool. The thermal cutout will operate if the duty cycle is exceeded.

The Firepower FP 125 is designed for 19% duty cycle at 90 Amps.

The Firepower FP 135 is designed for 20% duty cycle at 117 Amps.

The Firepower FP 165 is designed for 18% duty cycle at 140 Amps.

If the unit overheats and the thermostat opens, wait 15 minutes for unit to cool.

**Firepower 125 at Rated Duty Cycle**

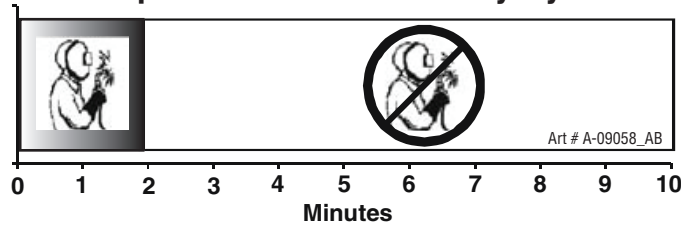

*Figure 2-5: Duty Cycle of Firepower 125*

**Firepower 135 at Rated Duty Cycle**

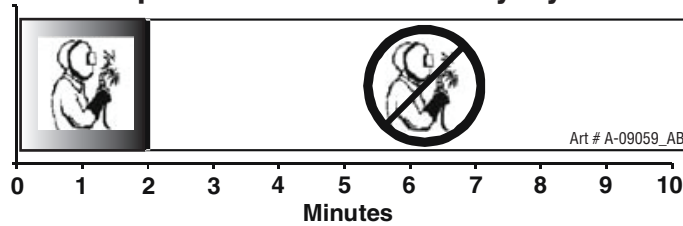

*Figure 2-6: Duty Cycle of Firepower 135*

**Firepower 165 at Rated Duty Cycle**

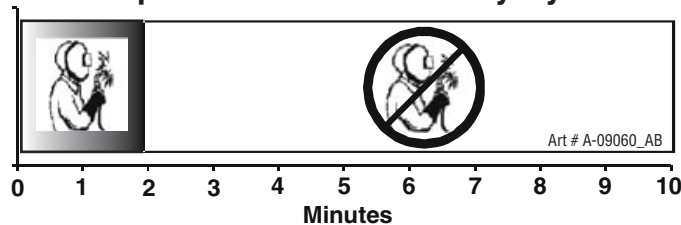

*Figure 2-7: Duty Cycle of Firepower 165*

# FIREPOWER FP 125,135,165

## 2.08 MIG Gun Maintenance

Remove dust and metallic particles from the gun conduit by forcing clean, dry compressed air into the conduit once a week. This will minimize wire feeding problems.

## 2.09 Handle / Feet Assembly

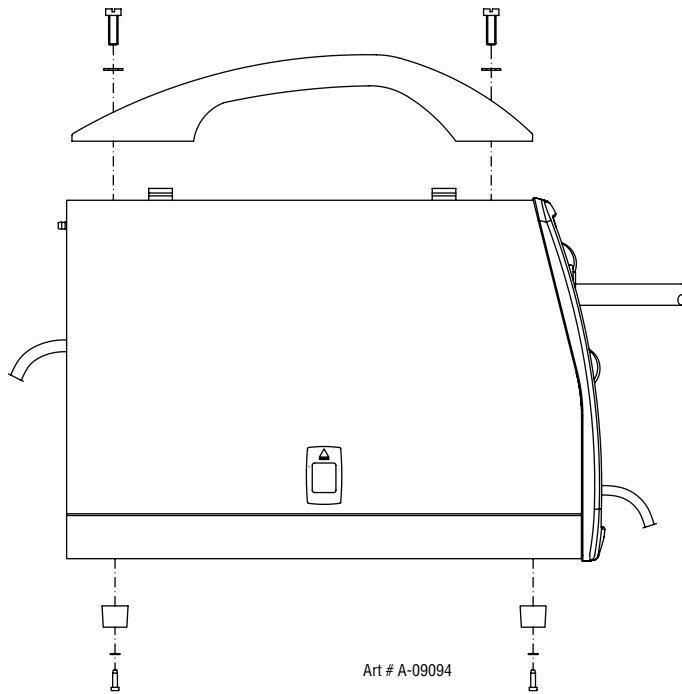

## SECTION 3: INSTALLATION

### 3.01 Location

For best operating characteristics and longest unit life, take care in selecting the installation site. Avoid locations exposed to high humidity, dust, high ambient temperature, or corrosive fumes. Moisture can condense on electrical components, causing corrosion or shorting of circuits. Dirt on components will retain this moisture and also increases wear on moving parts. Adequate air circulation is needed at all times in order to assure proper operation. Provide a minimum of 12" (300mm) of free air space at both the front and rear of the unit. Make sure that the ventilation openings are not obstructed.

	<p><b>CAUTION</b> These MIG machines are not suitable for use in rain.</p>
---	--

### 3.02 Safety

Refer to additional installation instructions under the SAFETY INSTRUCTIONS AND WARNINGS (Section 1) in this manual.

### 3.03 Grounding

The internal frame of this welding machine should be grounded for personal safety. Where grounding is mandatory under state or local codes, it is the responsibility of the user to comply with all applicable rules and regulations. Where no state or local codes exist, it is recommended that the National Electrical Code be followed.

### 3.04 Electrical Input Requirements

Plug the input cord into a properly grounded and protected (by fuse or circuit breaker) mains receptacle capable of handling a minimum of 20 Amperes. Firepower FP 125 & FP 135 requires a 120VAC supply voltage and the Firepower FP 165 requires a 230VAC supply voltage.

The Firepower FP 125 & FP 135's power cord is equipped with a NEMA 5-15P plug and will only connect to a NEMA 5-15P receptacle.

Except for some early models, the Firepower FP 165's power cord is equipped with a NEMA 6-50P plug and will only connect to a NEMA 6-50P receptacle.

	<p><b>CAUTION</b> Consult the nameplate for proper input voltage and input amperage. The method of installation, conductor size, and over-current protection shall conform to the requirements of the local electrical code. All installation wiring and machine connection shall be done by a competent electrician.</p>
---	---

The National Electrical Code (Article 630B) provides standards for amperage handling capability of supply conductors based on the duty cycle of the welding power source. The Firepower FP 125 has a 19% duty cycle (1 minute 54 seconds of every 10 minutes can be used for welding). The Firepower FP 135 has a 20% duty cycle (2 minutes of every 10 minutes can be used for welding). The Firepower FP 165 has an 18% duty cycle (1 minute 48 seconds of every 10 minutes can be used for welding). The power cords supplied with these units comply with these standards. Ensure that the building supply and receptacle comply with NEC standards and any additional state and local codes.

	<p><b>NOTE!</b> The supply wiring for the welding power source must be capable of handling a minimum of 20 amperes. The welding power source must be the only load connected to the supply circuit. Poor unit performance or frequently opening line fuses or circuit breakers can result from an inadequate or improper supply.</p>
--	--

	<p><b>CAUTION</b> Do not connect the Firepower FP 125 or 135 to an input power supply with a rated voltage that is greater than 120 +10% VAC. Do not remove the power cord ground prong.</p>
---	--

	<p><b>CAUTION</b> Do not connect the Firepower FP 165 to an input power supply with a rated voltage that is greater than 230 + 10% VAC. Do not remove the power cord ground prong.</p>
--	--

### 3.05 Requirements for Maximum Output

In order to obtain the maximum output capability of the Firepower FP 125 a branch circuit capable of 40 amperes at 115 to 125 Volts 60 Hz is required. In order to obtain the maximum output capability of the Firepower FP 135 a branch circuit capable of 50 amperes at 115 to 125 Volts 60 Hz is required. In order to obtain the maximum output capability of the Firepower FP 165 a branch circuit capable of 30 amperes at 208 to 230 Volts 60 Hz is required. This generally applies when welding steel that is equal to or greater than 12 gauge (0.105" 2.5mm) in thickness.

## 3.06 Installation of Shielding Gas (GMAW) Process

Refer to Figure 3-1.



### NOTE!

Shielding Gas is not required if the unit is using self-shielded FCAW (flux cored arc welding) wires.

1. **Cylinder Positioning:** Chain the cylinder to a wall or other support to prevent the cylinder from falling over. If an optional portable mounting arrangement is used, follow the instructions that are provided with it.
2. **Remove Cylinder Cap:** Remove the large metal cap on top of the cylinder by rotating counter clockwise. Next remove the dust seal.
3. **Cracking:** Position yourself so the valve is pointed away from you and quickly open and close the valve for a burst of gas. This is called "Cracking" and is done to blow out any foreign matter that may be lodged in the fitting.



### CAUTION

KEEP FACE WELL AWAY FROM THE CYLINDER VALVE DURING "CRACKING". Never "crack" a fuel gas cylinder valve near other welding works, sparks or open flames. Ensure that the surrounding area is well ventilated.

4. **Fit Regulator/Flowmeter to Cylinders:**

Screw the regulator into the appropriate cylinder. The nuts on the regulator and hose connections are right hand (RH) threaded and need to be turned in a clockwise direction in order to tighten. Tighten with a wrench.



### CAUTION

Match regulator to cylinder. NEVER CONNECT a regulator designed for a particular gas or gases to a cylinder containing any other gas.

5. **Attach Supplied Gas Line:** Attach supplied gas line between the regulator output and the desired input at the rear of the power supply depending on Spool Gun or MIG Gun use.

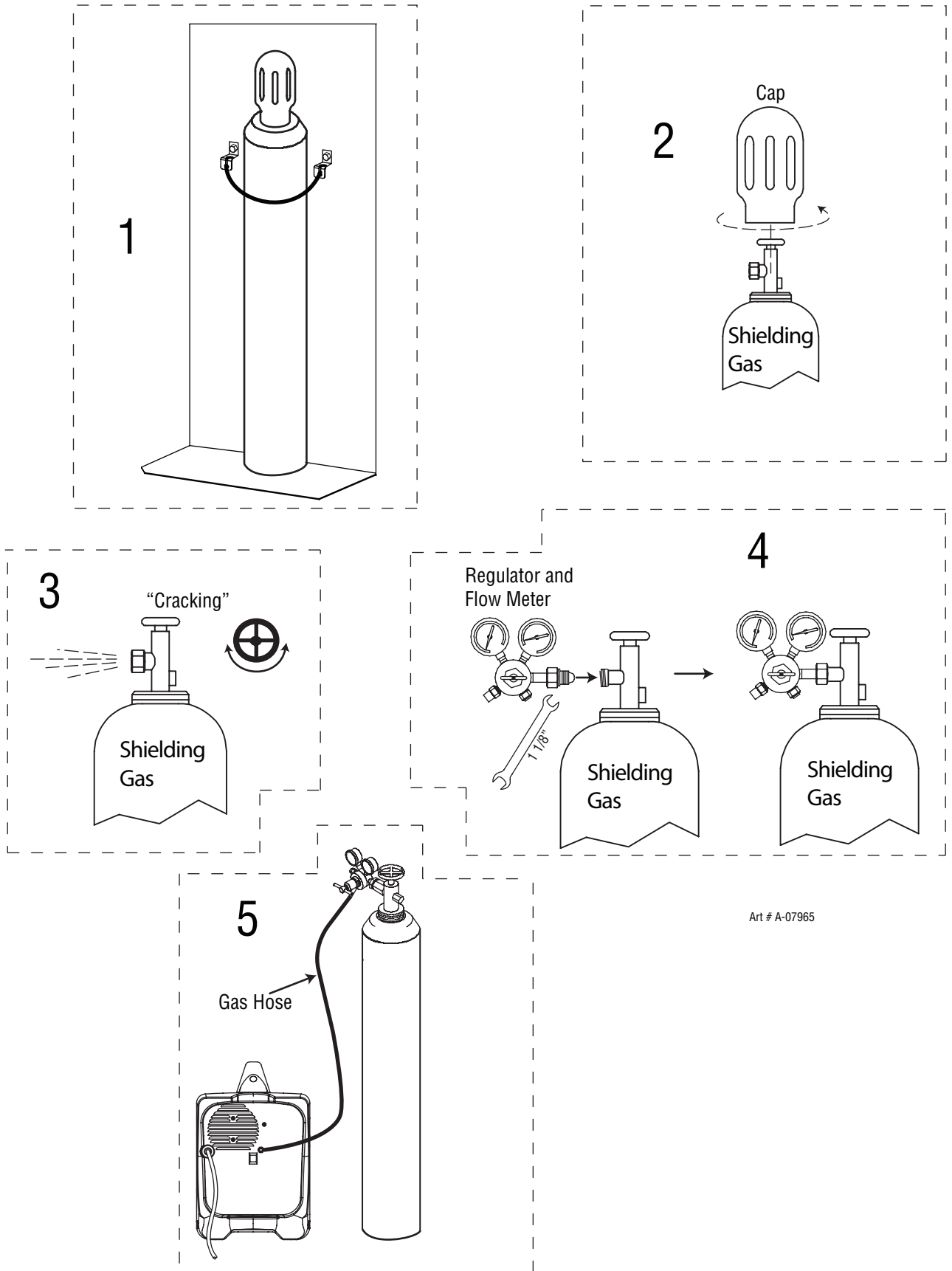

Figure 3-1 Gas Cylinder Installation for Reference Only!

# FIREPOWER FP 125,135,165

## Adjusting Regulator

Adjust control knob of regulator to the required flow rate, indicated on gauge dial. (Refer to Figure 3-2 and data charts. Approx. 20 CFH) The gas flow rate should be adequate to cover the weld zone to stop weld porosity. Excessive gas flow rates may cause turbulence and weld porosity.

Argon or argon based gas flow rates:

- Workshop welding: 20-30 CFH
- Outdoors welding: 30-40 CFH

Helium based or CO2 gas flow rates:

- Workshop welding: 30-40 CFH
- Outdoors welding: 40-50 CFH



### NOTE!

All valves downstream of the regulator must be opened to obtain a true flow rate reading on the outlet gauge. (Welding power source must be triggered) Close the valves after the pressure has been set.

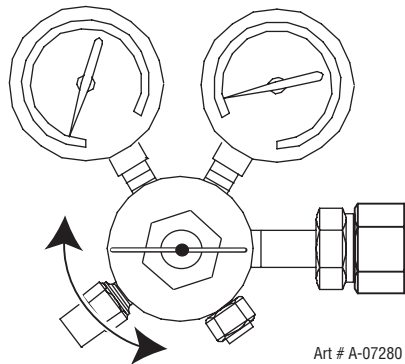

Figure 3-2: Adjusting flow rate. Illustration for Reference Only.

Refer to section 4.15 for suggested gas / filler metal combinations.



### NOTE!

The regulator/flowmeters used with argonbased and carbon dioxide shielding gases are different. The regulator/flow meter supplied is for argon based shielding gases. If carbon dioxide is to be used a suitable carbon dioxide regulator/flow meter will need to be fitted.

Two types of gas are generally used with Gas Metal Arc Welding (GMAW) of thin gauge sheet steel. A mixture of 75% Argon and 25% Carbon Dioxide (CO<sub>2</sub>) is recommended, Carbon Dioxide (CO<sub>2</sub>) can also be used.

## 3.07 Attaching the Gun and Cable Assembly to the Power Source

The Firepower FP 125, FP 135, FP 165 are supplied with a 80A MIG gun. The 80A MIG gun is designed with an ergonomic handle and fewer parts to eliminate performance problems. The 80A MIG gun uses standard readily available Firepower consumable parts.

1. Open the door to the machine.
2. Connect the gun cable to the power source by first routing the switch lead through the access hole in the front panel followed by the gun cable (see Figure 3-3).

**NOTE!**  
 Turn the cable end to align the gas hose nipple on the connector plug with the keyway located in the bottom of the front panel access hole.

3. Loosen the screws and insert the gun cable end as far as it will go. Tighten thumbscrew (see Figure 3-3).
4. Insert the gun switch plug into the gun switch socket (see Figure 3-3).
5. If shielding gas is being used, push the gas hose on to the gas hose nipple and secure it with the hose clamp.
6. To remove the gun, simply reverse these directions.

**CAUTION**  
 When disconnecting gun switch leads from the machine, grab the connectors and pull. Do not pull on the wires..

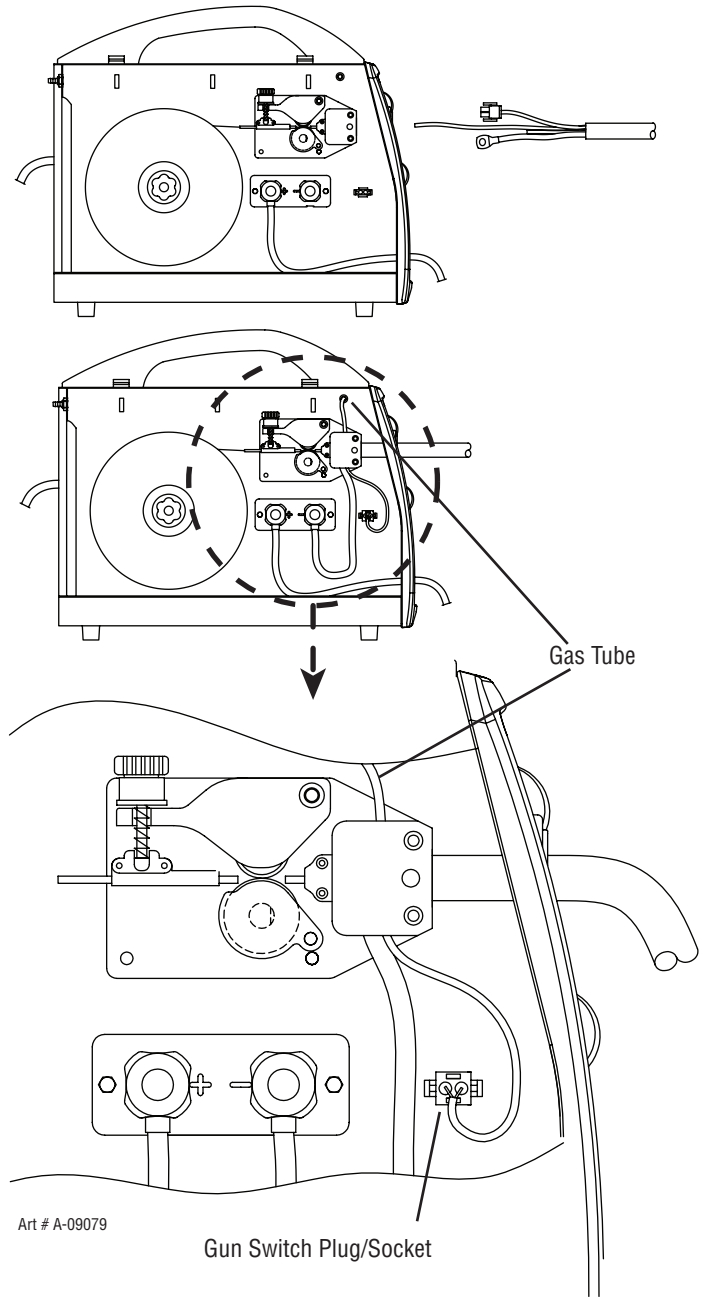

Figure 3-3: Attaching Gun and Cable

# FIREPOWER FP 125,135,165

## 3.08 Polarity Changeover



### WARNING

ELECTRIC SHOCK CAN KILL! Make certain the machine is unplugged from the power receptacle. Do not plug machine in until told to do so in these instructions

As delivered from the factory, the output polarity is set to the polarity which matches the welding wire supplied with the unit. The output terminals are located on the interior panel of the welding power source if you need to change polarity.

PROCESS	POLARITY	CABLE CONNECTIONS	
		CABLE TO GUN	CABLE TO WORK
1. GMAW – Solid Wire	1. DCEP – Reverse Polarity	1. Connected to (+) Pos. output terminal	1. Connected to (-) Neg. output terminal
2. FCAW – Self-shielding Wire – no Shielding Gas	2. DCEN – Straight Polarity	2. Connected to (-) Neg. output terminal	2. Connected to (+) Pos. output terminal

Table 3-1: Process Cable Connections

Connection for GMAW (reverse polarity DCEP)

1. Open the door to the machine.
2. Remove the polarity terminal knobs.
3. Set up the polarity (as per Table 3-1 above) by removing the leads from the terminals and reversing them if necessary. Refer to Figure 3-4.
4. Replace the polarity terminal knobs.



### NOTE!

Ensure that the polarity terminal knobs are tightly secured and that there is no connection between positive and negative terminals.

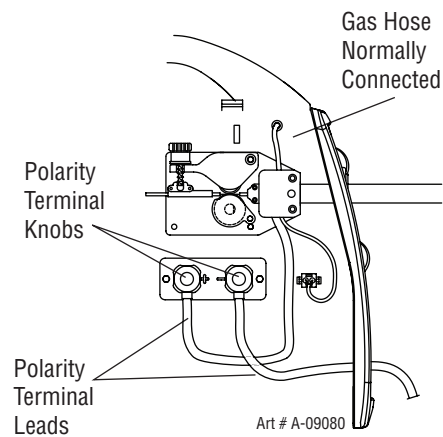

Figure 3-4: Connection for GMAW (reverse polarity DCEP)

Connection for FCAW (straight polarity DCEN)

1. Open the door to the machine.
2. Remove the polarity terminal knobs.
3. Set up the polarity (as per Table 3-1 above) by removing the leads from the terminals and reversing them if necessary. Refer to Figure 3-5.
4. Replace the polarity terminal knobs.



### NOTE!

Ensure that the polarity terminal knobs are tightly secured and that there is no connection between positive and negative terminals.

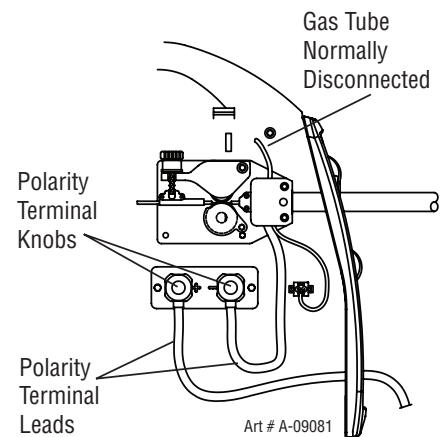

Figure 3-5: Connection for FCAW (straight polarity DCEN)

### 3.09 Installing Wire Spool

As delivered from the factory, the unit is set for an 4" (102mm) spool.

Installation of Wire Spool

Assemble parts in sequence (shown in Figure 3-6 from right to left).

1. Spool 4" (102mm)
2. External Ring
3. Retaining Spring
4. Nut

**NOTE!**  
Nut is tightened until a slight force is required to turn the spool.

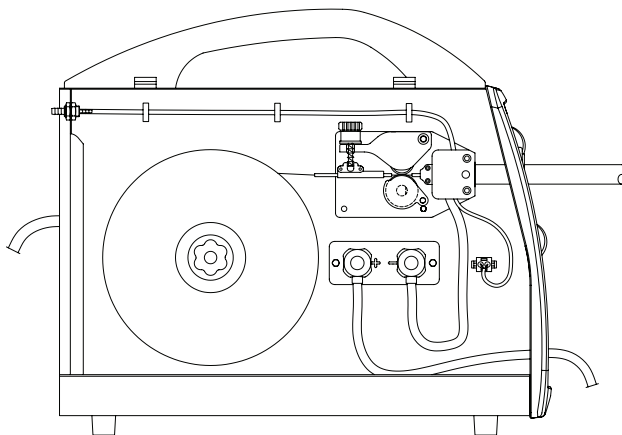
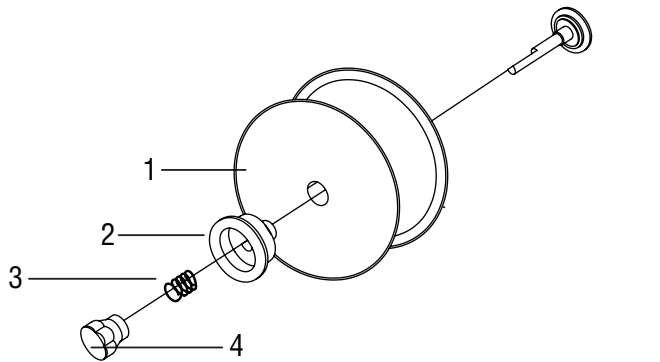

Art # A-09082

Figure 3-6: 4" Spool Installation

### 3.10 Feedrolls

A feedroll consists of two different sized grooves, .023" (0.6mm) and .030" / .035" (0.8mm / 0.9mm).

The branding inside at the end of the feedroll refers to the size nearest to the mark

This also applies to optional feedrolls which are available for this machine.

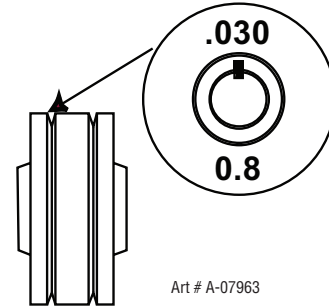

Art # A-07963

Figure 3-7 : Feedroll Example

### 3.11 Install Wire into the Feedhead



**WARNING**

ELECTRIC SHOCK CAN KILL! Make certain the machine is unplugged from the power receptacle. Do not plug machine in until told to do so in these instructions.

1. Loosen the nut of the spool holder (brake drum). Remove the spring and the external ring.
2. Remove the plastic protection from the spool. Place it on the spool holder again. Mount the external ring, the spring and the plastic lock nut again. These parts form the braking system for the wire spool. Tighten nut to appropriate tightness. Excessive pressure strains the wire feeding motor. Too little pressure does not allow the immediate stop of the wire spool at the end of the welding.



**CAUTION**

Use care in handling the spooled wire as it will tend to "unravel" when loosened from the spool. Grasp the end of the wire firmly and do not let go of it. Make sure that the end of the wire is free of any burrs and is straight.

# FIREPOWER FP 125,135,165

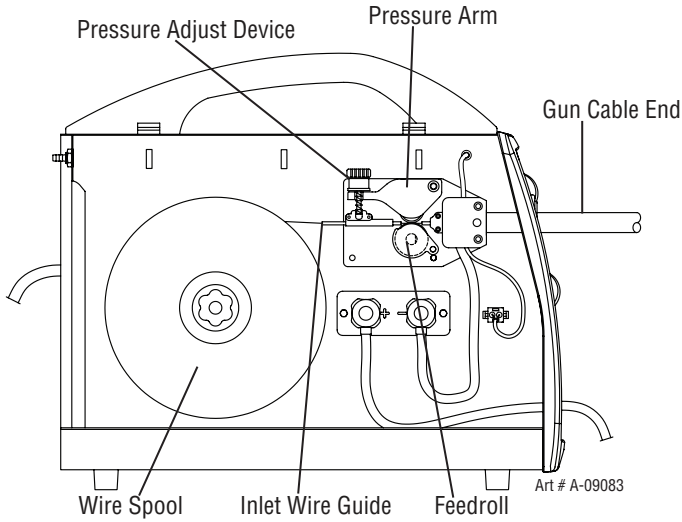

Figure 3-8: Wire Feeder Components

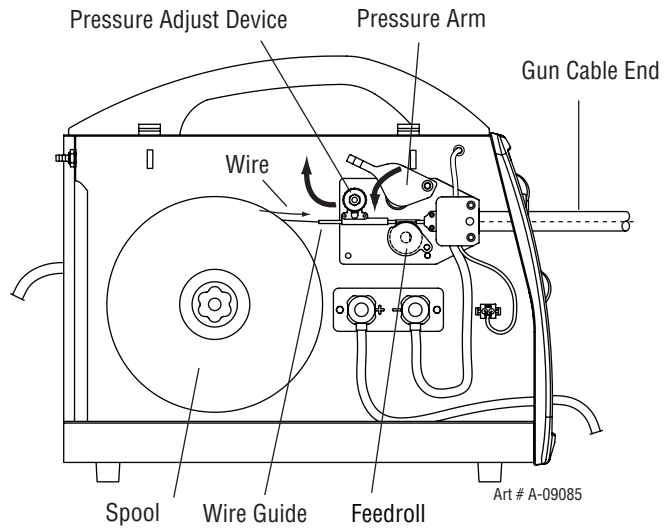

Figure 3-10: Inserting Wire

## Route the Wire Through the Feedhead

1. Loosen Pressure Adjust Device (Fig. 3-9).
2. Open Pressure Adjust Device (Fig. 3-9).
3. Open Pressure Arm (Fig. 3-9).
4. Place the end of the wire into the Inlet Wire Guide, feeding it over the Feedroll. Make certain that the proper groove is being used (Fig. 3-10).
5. Pass the wire into the Gun Liner of the Gun Cable End (Fig. 3-10).
6. Close the Pressure Arm (Fig. 3-10).
7. Close the Pressure Adjust Device. Tighten it to a “snug” condition (Fig. 3-10).
8. Figure 3-11 shows the result with the wire installed.

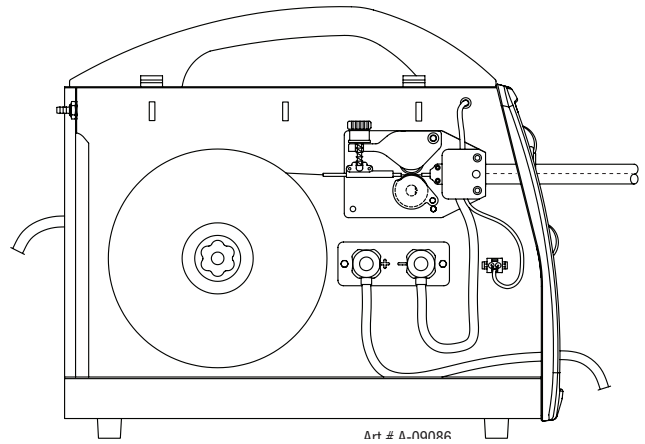

Figure 3-11: Wire Installed



### NOTE!

If there is too much pressure on the drive roll the wire gets locked and the motor could get damaged, If it is too loose the wire will not feed properly.

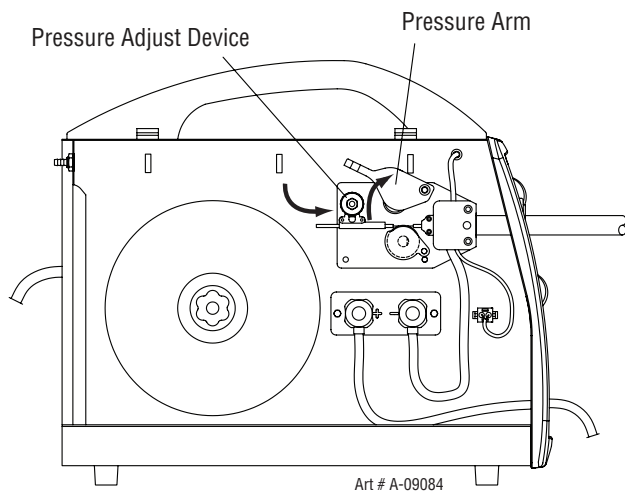



Figure 3-9: Opening Pressure Arm

## 3.12 Install Wire into the Welding Gun

1. Plug the Welding Power Source into the 120VAC receptacle for the Firepower FP 125 and FP 135, and into the 230VAC receptacle for the Firepower FP 165.



**WARNING**  
ELECTRIC SHOCK CAN KILL! With the gun switch (located on the gun) activated, welding power is applied to the output terminals, feedroll, ground clamp, gun cable connection and welding wire. Do not touch these parts with the gun switch activated. .

2. Turn the welding machine ON with the front panel Voltage Control Switch set to "1".

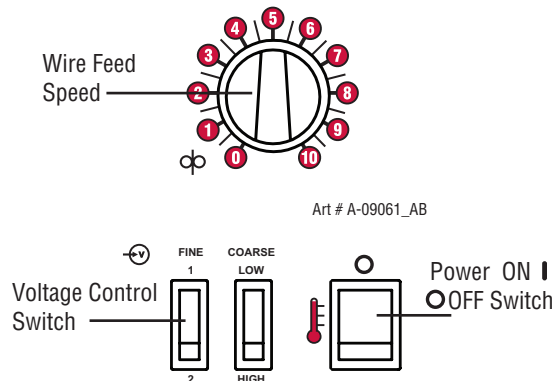

Figure 3--12: FP 125 Power ON

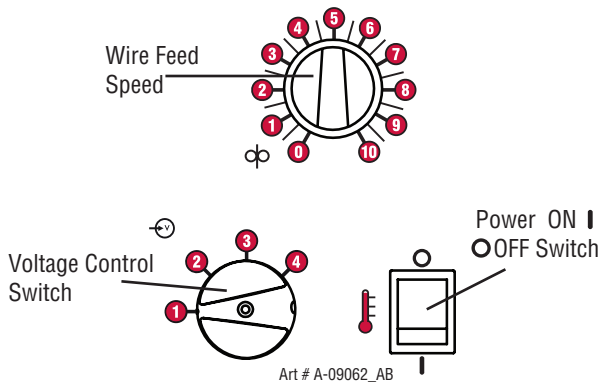

Figure 3--13: FP 135, 165 Power ON

3. Set the wire feed speed to half-way or "5".

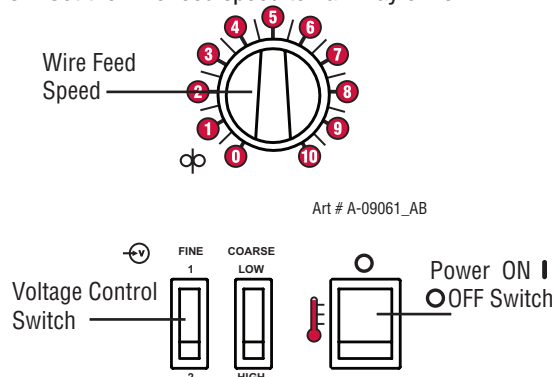

Figure 3-14: FP 125 Wire Speed Half-way

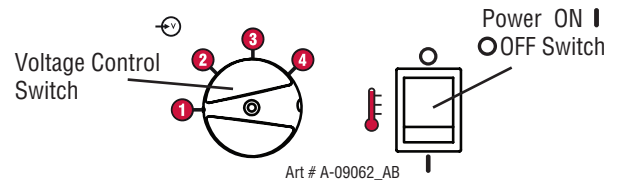
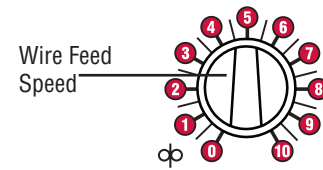



Figure 3-15: FP 135, 165 Wire Speed Half-way

4. Straighten the gun cable. Remove the nozzle and contact tip from the MIG welding gun (see Section 2.08).



**WARNING**  
If ground connection clamp is in place on the workpiece the electrode wire is electrically "hot" when the gun switch is activated.

5. Activate the gun switch until the wire feeds out past the gun nozzle.

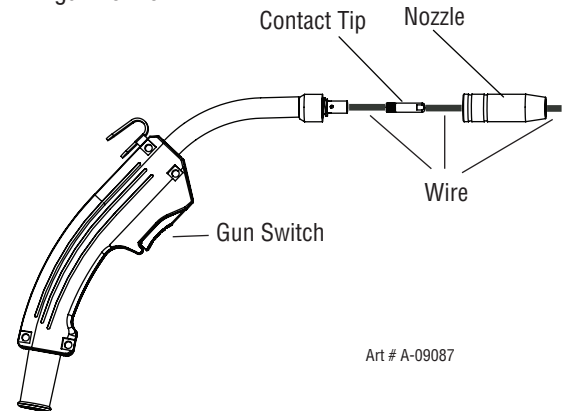

Figure 3-15: Feed Wire Through Gun

6. Deactivate the gun switch and set the Power Control Switch to "0 / OFF" and unplug the supply cord.
7. Replace the contact tip and nozzle. Cut the wire within 1/4" (6mm) from the nozzle.

This Page Intentionally Blank

## SECTION 4: OPERATION



### 4.01 General Safety Precautions

Read and understand the safety instructions at the beginning of this manual prior to operating this machine.



**WARNING**

Be sure to put on proper protective clothing and eye safeguards (welding coat, apron, gloves, and welding helmet, with proper lenses installed). See Safety Instructions and Warnings chapter included in this manual. Neglect of these precautions may result in personal injury.



**WARNING**

Make all connections to the power source including electrode and work cables, as well as remote control cables, with the power source turned off. These connections could be electrically live with the power switch ON.



**WARNING**

**ELECTRIC SHOCK CAN KILL!** Do not operate the machine with the door open.



**CAUTION**

Do not pull the machine with the gun. Damage can occur to the gun, gun liner and machine. Avoid bending the gun cable with a sharp radius. Damage can occur to the gun liner.

### 4.02 Firepower Controls

Refer to Figure 4-1 and 4-2.

1. Power ON / OFF switch turns the power on and off. It also lights when the power supply has gone into overtemp.
2. The Wire Speed Control knob controls the welding current via the electrode wire feed rate (i.e. the speed of the wire feed motor).
3. The Voltage Control Switch(s) sets the voltage level to the welding terminals. There are 4 positions available.



**CAUTION**

The Voltage Control Switch **MUST NOT BE SWITCHED** during the welding process. Some internal electrical components are at Mains voltage potential with this switch in the OFF position.



**CAUTION**

The Voltage Control Switch **MUST NOT BE SWITCHED** during the welding process. Some internal electrical components are at Mains voltage potential with this switch in the OFF position.

4. MIG Gun cable end and Gun Switch Leads are routed through this opening.
5. The Work Cable & Clamp connects to the item being welded (not shown).
6. The gas inlet nipple is used to connect the gas hose to the gas regulator for GMAW. Use the hose clamp to secure the hose to the gas nipple.
7. The moveable tension knob applies pressure to the grooved roller via screw-adjustable spring pressure. The adjustable spring screw should be adjusted to a minimum pressure that will provide satisfactory wire feed without slippage. If slipping occurs, and inspection of the wire contact tip reveals no wear, distortion or burn-back jam, the conduit liner should be checked for kinks and clogging by metal flakes and slag. If this is not the cause of slipping, the feedroll pressure can be increased by rotating the adjustable spring screw clockwise. The use of excessive pressure may cause rapid wear of the feed roller, motor shaft and motor bearings.
8. The Gun Adaptor connects the MIG Gun to the feedhead assembly.
9. The Gun Switch Connector is provided for connection of the Gun Switch Leads.
10. Negative (-) Welding Terminal.
11. Positive (+) Welding Terminal.

# FIREPOWER FP 125,135,165



## CAUTION

Loose welding terminal connections can cause overheating and result in the cables being fused to the welding terminals.

13. The wire reel hub incorporates a friction brake which is adjusted during manufacture for optimum braking. If it is considered necessary, adjustment can be made by turning the large nut inside the open end of the wire reel hub. Clockwise rotation will tighten the brake. Correct adjustment will result in the wire reel circumference continuing no further than 3/4" (20mm) after release of the Torch Trigger Switch. The wire should be slack without becoming dislodged from the reel.



## CAUTION

Excessive tension on the brake will cause rapid wear of mechanical wire feed parts, overheating of electrical components and possibly an increased incidence of wire burnback into the contact tip.

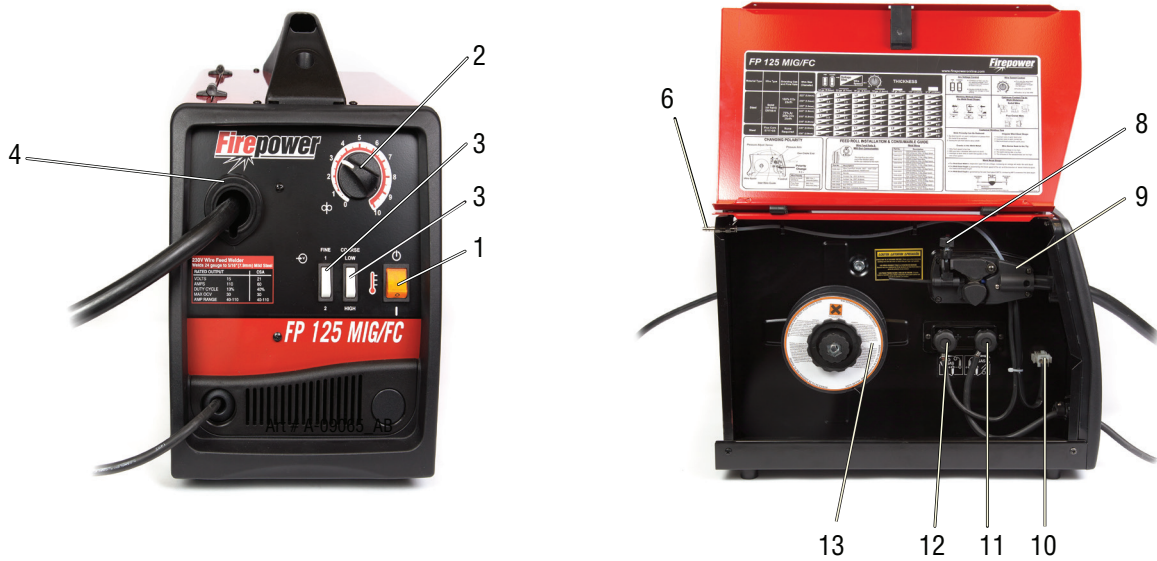

Figure 4-1: Firepower FP 125 Controls

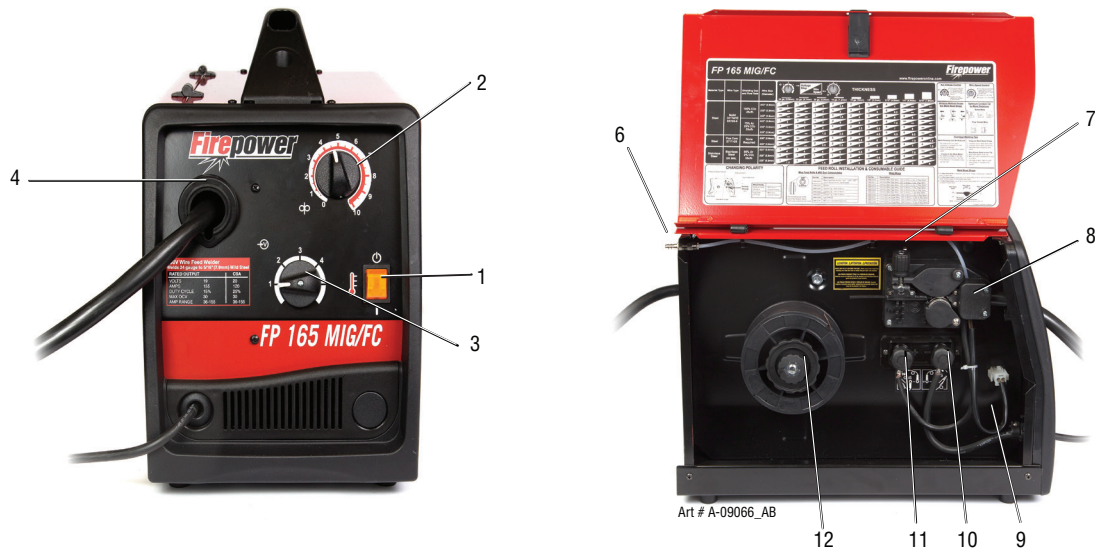

Figure 4-2: Firepower FP 135 and 165 Controls

### 4.03 Gas Metal Arc Welding (GMAW)

See Welding Guidelines included in this manual.

Make all necessary connections as instructed in the INSTALLATION chapter.

Place the WELD VOLTAGE RANGE SWITCH at the desired setting.

**CAUTION**

Do not turn the WELD VOLTAGE RANGE SWITCH clockwise past position 4, as damage to the switch may occur.

Plug the supply cord into a 120 VAC 40 Ampere receptacle for the FP 125, 120 VAC 50 Ampere receptacle for the 135 and into a 230 VAC 30 Ampere receptacle for the FP 165.

Open the gas cylinder valve to supply shielding gas to the gun. (optional gas regulator required on the FP 125)

Connect the WORK CLAMP to the workpiece (material to be welded).

Rotate the WIRE SPEED control to the desired setting.

Extend wire from the gun, and cut to proper stick-out for that type of wire (when welding always maintain this distance).

Position gun to where it is at approximately right angles to the workpiece with proper wire stick-out. Lower your welding helmet and pull the gun trigger switch.

**WARNING**

Be sure to put on proper protective clothing and eye safeguards (welding coat, apron, gloves, and welding helmet with proper lenses installed). See Safety Instructions and Warnings chapter included in this manual. Neglect of these precautions may result in personal injury.

Travel at a speed necessary to maintain a bead width from 1/8" to 1/4" (3mm to 6mm) depending on the thickness of the material. For material that may require larger weldments, either change to a larger diameter filler wire or use multi pass beads. On some applications, it may be necessary to adjust the voltage range to stabilize the arc.

Upon completion of the weld, release the gun trigger switch, raise the welding helmet, and visually examine the weld.

**NOTE!**

To help you overcome any problems that might arise, you will find useful information in section 4.06 Basic Welding Techniques..

### 4.04 Flux Cored Arc Welding (FCAW)

Follow the same general procedure as with the GMAW process above. Shielding gas is not required for self shielded type wires. For differences in the process see section 4.06 Basic Welding Techniques. Also included is information to solve any problem related to the FCAW process.

### 4.05 Shutdown Procedures

Close the cylinder valve (GMAW process only). Press gun switch to vent gas line (GMAW process only). Place the POWER ON/OFF SWITCH in the OFF position.

**WARNING**

After releasing the gun switch, the electrode wire will remain electrically "hot" for several seconds.

### 4.06 Basic Welding Technique

#### General

Two different welding processes are covered in this section, with the intention of providing the very basic concepts in using the semi-automatic mode of welding. In this mode, the welding gun is hand-held. The electrode (welding wire) is then fed into a weld puddle and the arc is shielded by a gas or gas mixture.

#### Setting of the Power Supply

The settings of the Firepower requires some practice by the operator in that the welding Power Supply has two control settings that need to balance. These are the Wire Speed control and the Voltage Control switches. The welding current is determined by the Wire Speed control (i.e., the current will increase with increased wire speed, resulting in a shorter arc). Slower wire speed will reduce the current and lengthen the arc. Increasing the welding voltage hardly alters the welding current level, but lengthens the arc. By decreasing the voltage, a shorter arc is obtained with little change in welding current.

## FIREPOWER FP 125,135,165

When changing to a different electrode wire diameter, different control settings are required. A thinner electrode wire needs more wire speed to achieve the same current level.

A satisfactory weld cannot be obtained if the wire speed and voltage switch settings are not adjusted to suit the electrode wire diameter and dimensions of the work piece.

If the wire speed is too high for the welding voltage, "stubby" will occur as the wire dips into the molten pool and does not melt. Welding in these conditions normally produces a poor weld due to lack of fusion. If however, the welding voltage is too high, large drops will form on the end of the electrode wire, causing spatter. The correct setting of voltage and wire speed can be seen in the shape of the weld deposit and heard by a smooth regular arc sound.

### GAS METAL ARC WELDING (GMAW)

This process, also known as MIG welding, CO<sub>2</sub> welding, Micro Wire Welding, short arc welding, dip transfer welding, wire welding etc., is an electric arc welding process which fuses together the parts to be welded by heating them with an arc between a solid, continuous, consumable electrode and the work. Shielding is obtained from an externally supplied gas or gas mixture. The process is normally applied semi-automatically; however the process may be operated automatically and can be machine operated. The process can be used to weld thin and fairly thick steels, and some non-ferrous metals in all positions.

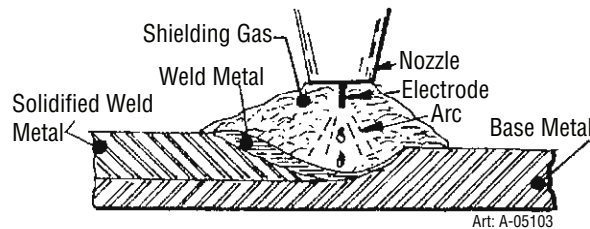

Figure 4-3: GMAW Process

### FLUX CORED ARC WELDING (FCAW)

This process also known as Open arc, Innershield, FAB Shield, etc., is an electric arc welding process which fuses together the parts to be welded by heating them with an arc between a continuous flux filled electrode wire and the work. Shielding is obtained through decomposition of the flux within the tubular wire. The process is normally applied semi-automatically; however the process may be applied automatically or by machine. It is commonly used to weld large diameter electrodes in the flat and horizontal position and small electrode diameters in all positions. The process is used to a lesser degree for welding stainless steel and for overlay work.

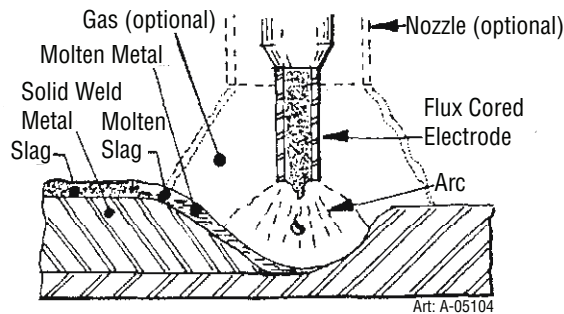

Figure 4-4: FCAW Process



#### WARNING

Follow these instructions only after referring to the Safety Instructions and Warnings chapter of this manual, and the instructions in the Installation chapter. .

#### Check List Before Starting

POLARITY – DCEP (Direct Current Electrode Positive) or DCEN (Direct Current Electrode Negative)

WIRE FEED SPEED – 1 to 10

VOLTAGE RANGE SWITCH SETTING – 1 to 4 for FP 135, 165 and two switches and 1-2 and Low-High for FP 125.

GAS FLOW RATE – 15 to 25 CFH (If shielding gas is required)

ELECTRODE WIRE STICK-OUT – approx 3/8" (10mm)

## 4.07 Welding Gun Positions

The welding gun should be held at an angle to the weld joint (see Secondary Adjustment Variables in Section 4.08). Hold the gun so that the welding seam is viewed at all times. Always wear the welding helmet with proper filter lenses.



**CAUTION**

Do not pull the welding gun back when the arc is established. This will create excessive wire extension (stickout) and make a very poor weld.

The electrode wire is not energized until the gun trigger switch is depressed. The wire may therefore be placed on the seam or joint prior to lowering the helmet.

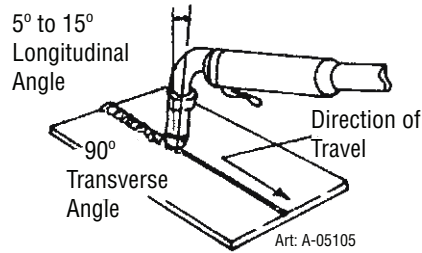

Figure 4-5: Butt and Horizontal Welds

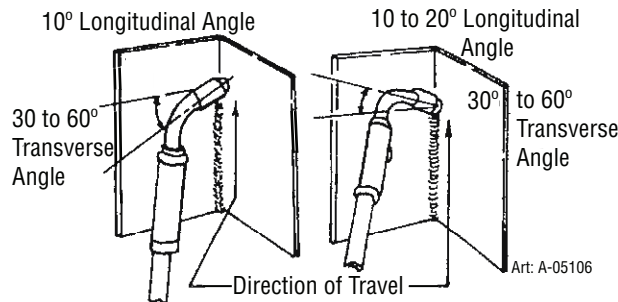

Figure 4-6: Vertical Weld

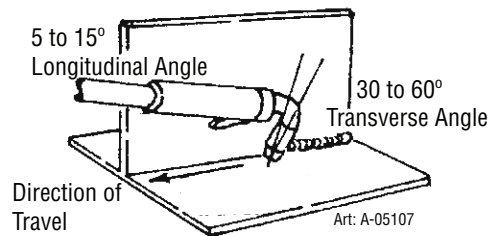

Figure 4-7: Horizontal Fillet Weld

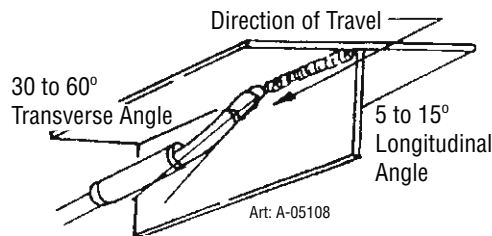

Figure 4-8: Overhead

## 4.08 MIG Welding (GMAW) Variables

Most of the welding done by all processes is on carbon steel. The following items describe the welding variables in short-arc welding of 24 gauge (0.024", 0.6mm) to 1/4" (6.4mm) mild sheet or plate. The applied techniques and end results in the GMAW process are controlled by these variables.

### Pre-selected Variables

Pre-selected variables depend upon the type of material being welded, the thickness of the material, the welding position, the deposition rate and the mechanical properties. These variables are:

1. Type of electrode wire
2. Size of electrode wire
3. Type of gas (not applicable to self-shielding wires FCAW)
4. Gas flow rate (not applicable to self-shielding wires FCAW)

### Primary Adjustable Variables

These control the process after Pre-selected Variables have been found. They control the penetration, bead width, bead height, arc stability, deposition rate and weld soundness. They are:

1. Arc Voltage
2. Welding Current (wire feed speed)
3. Travel Speed

### Secondary Adjustable Variables

These variables cause changes in primary adjustable variables which in turn cause the desired change in the bead formation. They are:

1. Stickout—distance between the end of the contact tube (tip) and the end of the electrode wire. Keep this at about 3/8" (10mm) stickout (as shown in Figure 4-8).

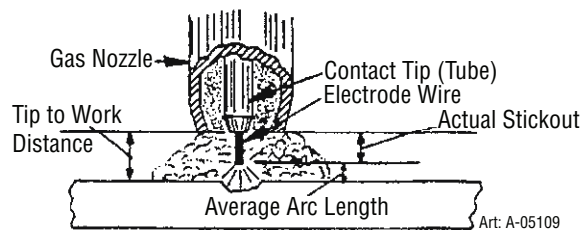

Figure 4-9: Electrode Stick-Out

2. Wire Feed Speed. Increase in wire feed speed increases weld current. Decrease in wire feed speed decreases weld current.
3. Nozzle Angle. (Figures 4-9 and 4-10) This refers to the position of the welding gun in relation to the joint. The transverse angle is usually one half the included angle between plates forming the joint. The longitudinal angle is the angle between the center line of the welding gun and a line perpendicular to the axis of the weld. The longitudinal angle is generally called the Nozzle Angle and can be either trailing (pulling) or leading (pushing). Whether the operator is left-handed or right-handed has to be considered to realize the effects of each angle in relation to the direction of travel.

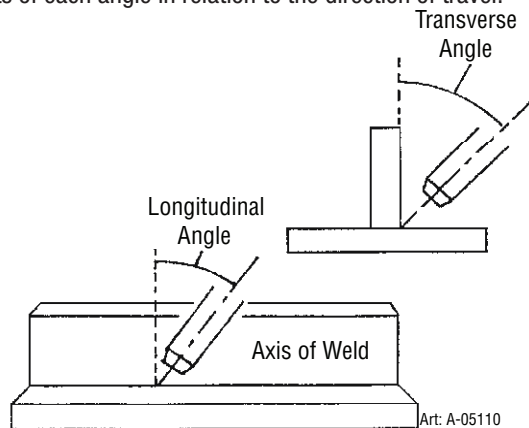

Figure 4-10: Transverse and Longitudinal Nozzle Axes

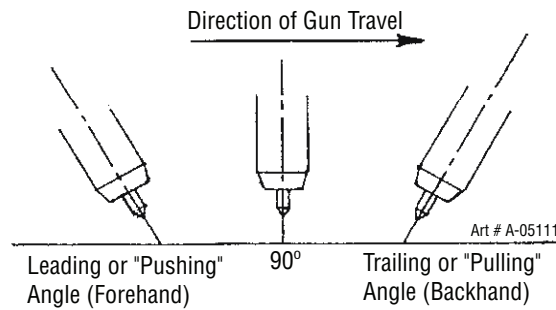

Figure 4-11: Nozzle Angle, Right-Handed Operator

## 4.09 Establishing the Arc and Making Weld Beads

Before attempting to weld on a finished piece of work, it is recommended that practice welds be made on a sample metal of the same material as that of the finished piece.

The easiest MIG welding procedure for the beginner to experiment with, is the flat position. This equipment is capable of flat, vertical and overhead positions.

For practicing MIG welding, secure some pieces of 16 or 18 gauge (0.06" 1.5mm or 0.08" 2.0mm) mild steel plate 6" x 6" (150 x 150mm). Use 0.024" (0.6mm) wire and 75% Argon / 25% CO2 shielding gas.

## 4.10 Pre-Weld Procedure

1. Check the OPERATION chapter of this manual for details on this equipment.
2. Set the welding voltage range switch at position 1 or 2.
3. Set the wire feed speed control to about the 2.5 setting. Readjust as necessary.
4. Adjust the gas flow rate to about 20 cubic feet per hour (15 - 20 lpm).
5. Review standard safe practice procedures in ventilation, eye and face protection, fire, compressed gas and preventative maintenance. See Safety Instructions and Warnings chapter included in this manual.

## 4.11 Welding Procedure

1. Maintain the tip to work distance (stickout) at 5/16" to 3/8" (8 to 9mm) at all times.
2. For transverse and longitudinal nozzle angles, see section 4.07 Welding Gun Positions.
3. Hold the gun about 3/8" (9mm) from the work, lower the helmet by shaking your head and squeeze the trigger to start the wire feeding, and establish the arc.



**NOTE!**

Get in the habit of shaking the helmet down, rather than using the hands. One hand must hold the gun, and the other is often needed to hold pieces to be tacked or positioned.

4. Make a single down-hand (pulling) stringer weld bead.
5. Practice welding beads. Start at one edge and weld across the plate to the opposite edge.



**NOTE!**

When the equipment is properly adjusted, a rapidly cracking or hissing sound of the arc is a good indicator of correct arc length.

6. Practice stopping in the middle of the plate, restarting into the existing weld crater and continuing the weld bead across the plate.



**NOTE!**

When the gun trigger is released after welding, the electrode forms a ball on the end. To the new operator, this may present a problem in obtaining the penetration needed at the start of the next weld. This can be corrected by cutting the ball off with wire cutters.

# FIREPOWER FP 125,135,165

## 4.12 Reference Tables

The following tables are provided as user aids when performing MIG or FLUX CORED welding.

Type of Gas	Typical Mixtures	Primary Uses
Carbon Dioxide (CO2)		Mild and low alloy steels
Argon (Ar) - Carbon Dioxide (CO2)	75% Ar – 25% CO2	Mild and low alloy steelsStainless Steel
Argon (Ar)		Aluminum

Table 4-1: Type of Gas

Result Desired	Welding Variable						
	Arc Voltage	Welding Current (wire speed)	Travel Speed	Nozzle Angle	Stick out	Wire size	Gas Type
Deeper Penetration		<sup>1</sup> Increase		<sup>3</sup> Trailing Max 25°	<sup>2</sup> Decrease	<sup>5</sup> Smaller (*)	<sup>4</sup> CO <sub>2</sub>
Shallower Penetration		<sup>1</sup> Decrease		<sup>3</sup> Leading	<sup>2</sup> Increase	<sup>5</sup> Larger	<sup>4</sup> Ar CO <sub>2</sub> mix
Larger Bead		<sup>1</sup> Increase	<sup>2</sup> Decrease		<sup>3</sup> Increase (*)		
Smaller Bead		<sup>2</sup> Decrease	<sup>2</sup> Increase		<sup>3</sup> Decrease (*)		
Higher Narrower Bead	<sup>1</sup> Decrease			<sup>2</sup> Trailing	<sup>3</sup> Increase		
Flatter Wider Bead	<sup>1</sup> Increase			<sup>2</sup> 90° or Leading	<sup>3</sup> Decrease		
Faster Deposition Rate		<sup>1</sup> Increase			<sup>2</sup> Increase (*)	<sup>3</sup> Smaller	
Slower Deposition Rate		<sup>1</sup> Decrease			<sup>2</sup> Decrease (*)	<sup>3</sup> Larger	

Key: (1) First Choice, (2) Second Choice, (3) Third Choice, (4) Fourth Choice, (5) Fifth Choice

Table 4-2: Welding Variables



**NOTE!**

Same adjustment is required for wire feed speed.

\* When these variables are changed, the wire feed speed must be adjusted so that the welding current remains constant. See DEPOSITION RATE in the WELDING VARIABLES section. This change is especially helpful on materials of 20 gauge (.04" 1mm approximately) and smaller in thickness.

**4.13 Firepower FP 125 Welding Setting Selection Guide**

Material Type	Wire Type	Shielding Gas and Flow Rate	Wire Size (Diameter)
Steel	Solid (or hard) ER70S-6	100% CO <sub>2</sub> 25cfh	.023" (0.6mm)
			.030" (0.8mm)
			.035" (0.9mm)
		75% Ar 25% CO <sub>2</sub> 25cfh	.023" (0.6mm)
			.030" (0.8mm)
			.035" (0.9mm)
Steel	Flux Core E71T-GS	None Required	.030" (0.8mm)
			.035" (0.9mm)

Art # A-09030\_AB

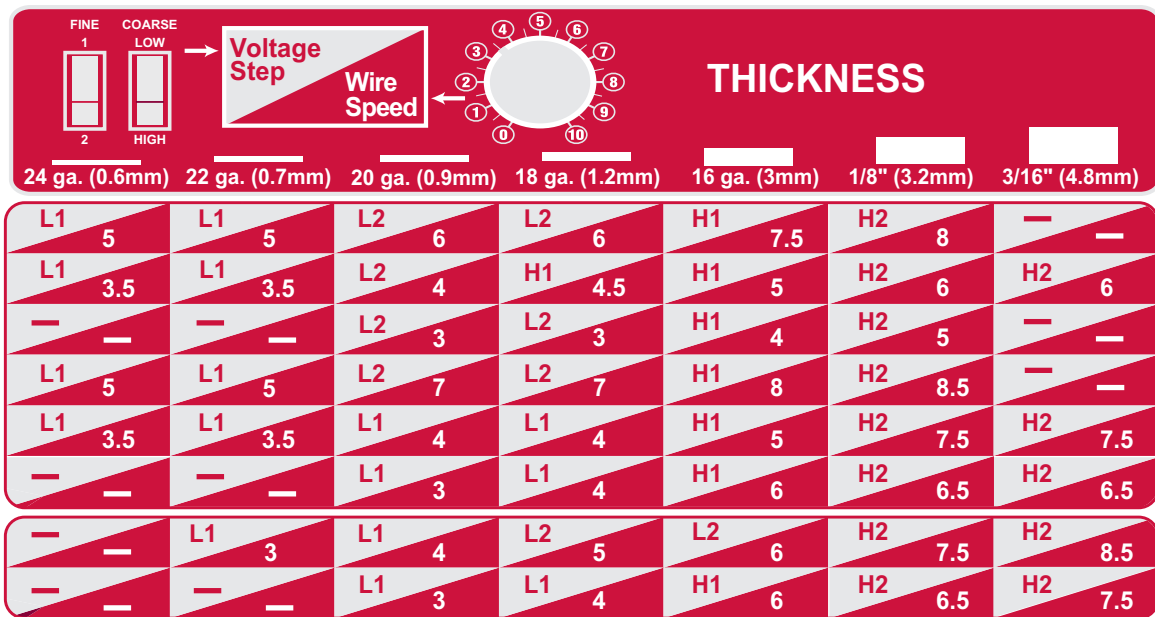

Figure 4-12: FP 125 Selection Guide

# FIREPOWER FP 125,135,165

## 4.14 Firepower FP 135 Welding Setting Selection Guide

Material Type	Wire Type	Shielding Gas and Flow Rate	Wire Size (Diameter)
Steel	Solid (or hard) ER70S-6	100% CO <sub>2</sub> 25cfh	.023" (0.6mm)
			.030" (0.8mm)
		75% Ar 25% CO <sub>2</sub> 25cfh	.023" (0.6mm)
			.030" (0.8mm)
Steel	Flux Core E71T-GS	None Required	.030" (0.8mm)
			.035" (0.9mm)
Stainless Steel	Stainless Steel ER 308L	98% Ar 2% CO <sub>2</sub> 35cfh	.023" (0.6mm)
			.030" (0.8mm)
			.035" (0.9mm)

Art # A-09031\_AB

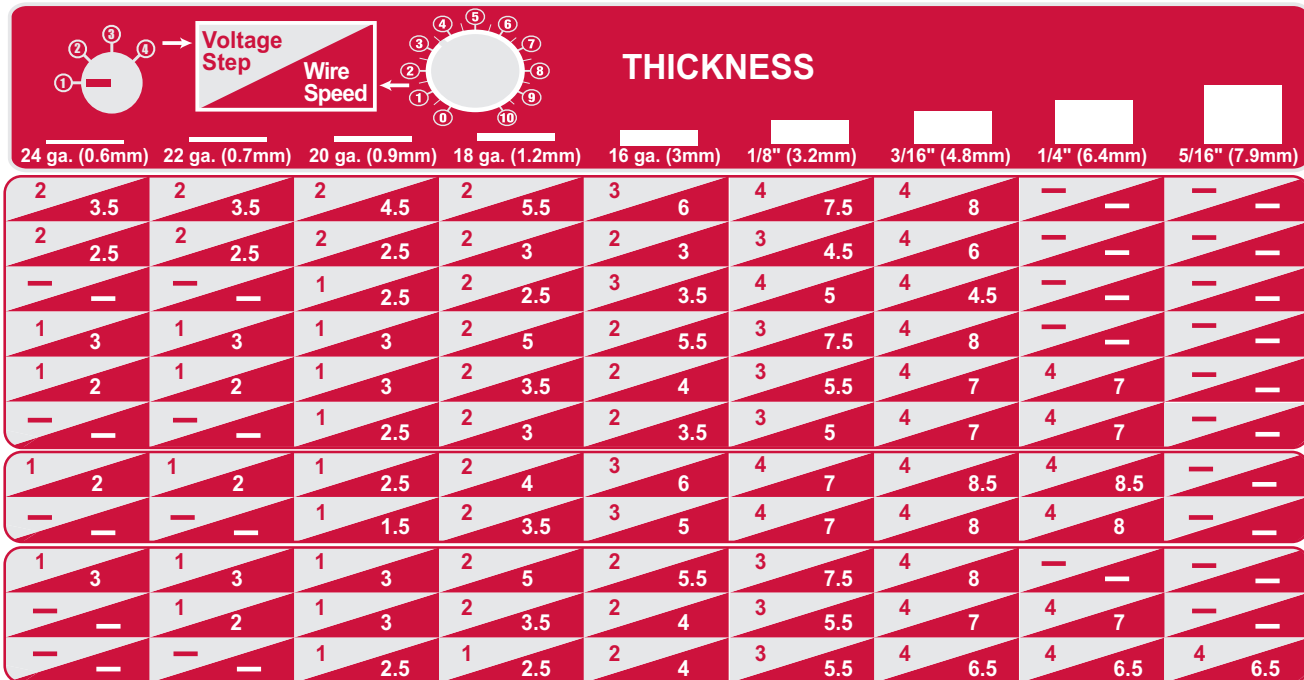

Figure 4-13: FP 135 Selection Guide

**4.15 Firepower FP 165 Welding Setting Selection Guide**

Material Type	Wire Type	Shielding Gas and Flow Rate	Wire Size (Diameter)
Steel	Solid (or hard) ER70S-6	100% CO <sub>2</sub> 25cfh	.023" (0.6mm)
			.030" (0.8mm)
			.035" (0.9mm)
		75% Ar 25% CO <sub>2</sub> 25cfh	.023" (0.6mm)
			.030" (0.8mm)
			.035" (0.9mm)
Steel	Flux Core E71T-GS	None Required	.030" (0.8mm) .035" (0.9mm)
Stainless Steel	Stainless Steel ER 308L	98% Ar 2% CO <sub>2</sub> 35cfh	.023" (0.6mm)
			.030" (0.8mm)
			.035" (0.9mm)

Art # A-09032\_AB

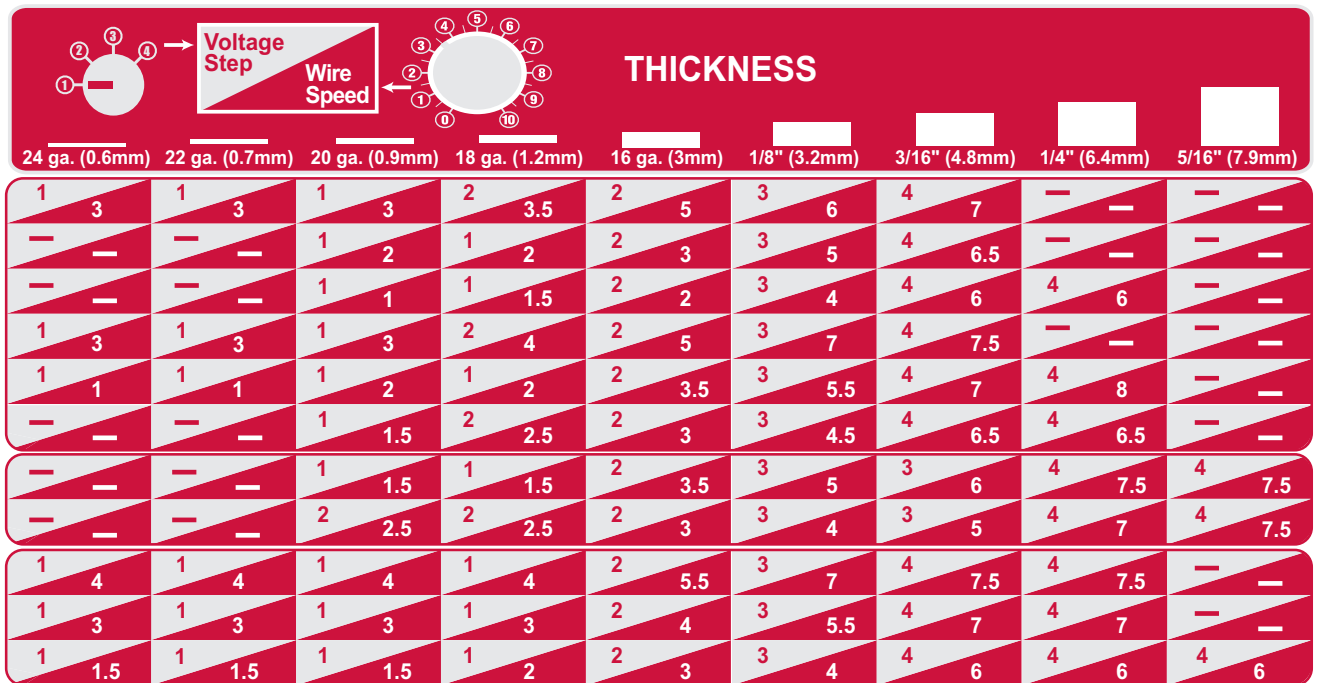

Figure 4-14: FP 165 Selection Guide

# FIREPOWER FP 125,135,165

## 4.16 Gas Selection for Gas Metal Arc Welding

Metal Type	Base Plate Thickness	Filler Metal	Transfer Mode	Suggested Shielding Gas	Welding Positions	Comments
<b>Carbon Steel</b>	Greater than 22 gauge (.030")	ER70S-X	Short Circuit	100% CO <sub>2</sub>	All Position Welding	High welding speeds. Good penetration and pool control.
	Greater than 22 gauge (.030")	ER70S-X	Short Circuit	75% Argon 25% CO <sub>2</sub>	All Position Welding	Suitable for high-current and high-speed welding.
	Greater than 22 gauge (.030")	ER70S-X	Short Circuit	92% Argon 8% CO <sub>2</sub>	All Position Welding	Higher deposition rates without melt-through. Minimum distortion and spatter. Good pool control for out-of-position welding.
	Greater than 10 gauge (1/8")	ER70S-X	Spray Transfer	92% Argon 8% CO <sub>2</sub>	Flat & HV Fillet	Good arc stability, weld soundness, and increasing width of fusion.
<b>Low Alloy and High Alloy Steel</b>	Greater than 22 gauge (.030")	See Note 1	Short Circuit Globular	75% Argon 25% CO <sub>2</sub>	All Position Welding	High welding speeds. Good penetration and pool control. Applicable for out-of-position welds. Suitable for high-current and high-speed welding.
	Greater than 22 gauge (.030")	See Note 1	Short Circuit	92% Argon 8% CO <sub>2</sub>	All Position Welding	Good coalescence and bead contour. Good mechanical properties.
	Greater than 3/32"	See Note 1	Spray transfer	92% Argon 8% CO <sub>2</sub>	Flat & HV Fillet	Reduces undercutting. Higher deposition rates and improved bead wetting. Deep penetration and good mechanical properties.
	Greater than 14 gauge (.075")	See Note 1	Short Circuit	98% Argon 2% CO <sub>2</sub>	All Position Welding	Good control of melt-through and distortion. Used also for spray arc welding. Pool fluidity sometimes sluggish depending on the base alloy.
<b>Stainless Steel</b>	Greater than 22 gauge (.030")	ER308-X ER309-X ER316-X	Short Circuit	90% Helium 7.5% Argon 2.5% CO <sub>2</sub> or 81% Argon 18% Helium 1% CO <sub>2</sub>	All Position Welding	Low CO <sub>2</sub> percentages in Helium mix minimizes carbon pickup, which can cause intergranular corrosion with some alloys. Helium improves wetting action and contour. CO <sub>2</sub> percentages above 5% should be used with caution on some alloys.
	Greater than 3/32"	ER308-X ER309-X ER316-X	Spray Transfer	90% Helium 7.5% Argon 2.5% CO <sub>2</sub> or 81% Argon 18% Helium 1% CO <sub>2</sub>	Flat & HV Fillet	Good arc stability. Produces a fluid but controllable weld pool, good coalescence, and bead contour. Minimizes undercutting on heavier thickness.
<b>Aluminum</b>	Greater than 18 gauge (.045")	ER4043 ER5356	Spray Transfer	Argon	All Position Welding	Excellent cleaning action. Provides more stable arc than helium-rich mixtures.

**Note 1: Contact your Filler Metal Supplier for recommended filler metal for the base metal to be welded.**

Table 4-3: Gas Selection GMAW

## SECTION 5: SERVICE

### 5.01 Cleaning of the Unit

Periodically remove the right side panel (after disconnecting the supply cord from the receptacle) and blow out the interior with clean, dry, compressed air of not more than 25 PSI air pressure. Do not strike any components with the air hose nozzle.

### 5.02 Cleaning of the Feed Rolls

Clean the wire groove on the feed roll at frequent intervals. This cleaning operation can be done by using a small wire brush. To clean the wire groove, loosen the pressure device and lift the feedroll pressure arm. Remove all wire from the feedhead. Wipe off the bearing roll (the “top” roll in the feedhead).

### 5.03 Basic Troubleshooting

The basic level of troubleshooting is that which can be performed without special equipment or knowledge, and without removing the covers from the Power Source. If major components are faulty, then the Power Source should be returned to an Accredited Firepower Service Agent for repair.

### 5.04 Solving Problems Beyond the Welding Terminals



**NOTE!**

The general approach to fix Gas Metal Arc Welding (GMAW) problems is to start at the wire spool then work through to the MIG torch. There are two main areas where problems occur with GMAW:

#### 1. Porosity

When there is a gas problem the result is usually porosity within the weld metal. Porosity always stems from some contaminant within the molten weld pool which is in the process of escaping during solidification of the molten metal.

Contaminants range from no gas around the welding arc to dirt on the work piece surface. Porosity can be reduced by checking the following points:

1. *Gas cylinder contents and flow meter.*
  - a. Ensure that the gas cylinder is not empty and the flow meter is correctly adjusted to 20CFM (15 liters per minute).
2. *Gas leaks*
  - a. Check for gas leaks between the regulator/cylinder connection and in the gas hose to the Power Source.
3. *Internal gas hose in the Power Source.*
  - a. Ensure the hose from the solenoid valve to the MIG torch adaptor has not fractured and that it is connected to the MIG torch adaptor.

4. *Welding in a windy environment.*
  - a. Shield the weld area from the wind or increase the gas flow.
5. *Welding dirty, oily, painted, oxidized or greasy plate.*
  - a. Clean contaminates off the plate.
6. *Distance between the MIG torch nozzle and the work piece.*
  - a. Keep the distance between the MIG torch nozzle and the work piece to a minimum.
7. *Maintain the MIG torch in good working order.*
  - a. Ensure that the gas holes are not blocked and gas is exiting out of the torch nozzle. Refer to WARNING below.
  - b. Do not restrict gas flow by allowing spatter to build up inside the MIG torch nozzle.



**WARNING**

Disengage the drive roll when testing for gas flow by ear.

#### 2. Inconsistent wire feed

Wire feeding problems can be reduced by checking the following points:

1. *Wire spool brake is too tight.*
  - a. Feed roller driven by motor in the cabinet will slip.
2. *Wire spool brake is too loose.*
  - a. Wire spool can unwind and tangle.
3. *Worn or incorrect feed roller size.*
  - a. Use ‘U’ groove drive feed roller matched to the aluminum wire size you are welding. Use ‘V’ groove drive feed roller matched to the steel wire size you are welding. Use ‘knurled V’ groove drive feed roller matched to the flux cored wire size you are welding.
4. *Misalignment of inlet/outlet guides.*
  - a. Wire will rub against the misaligned guides and reduces wire feedability.
5. *Liner blocked with slag.*
  - a. Slag is produced by the wire passing through the feed roller, if excessive pressure is applied to the pressure roller adjuster. Slag can also be produced by the wire passing through an incorrect feed roller groove shape or size. Slag is fed into the liner where it accumulates, thus reducing wire feedability.

# ESAB FIREPOWER FP-125,135,165

## 6. Incorrect or worn contact tip.

- a. The contact tip transfers the weld current to the electrode wire. If the hole in the contact tip is too large, then arcing may occur inside the contact tip resulting in the electrode wire jamming in there. When using soft electrode wire such as aluminum, the wire may become jammed in the contact tip due to expansion of the wire when heated. A contact tip designed for soft electrode wires should be used.

## 7. Poor work lead contact to work piece.

- a. If the work lead has a poor electrical contact to the work piece, then the connection point will heat up and result in a reduction of power at the arc.

## 8. Bent liner.

- a. This will cause friction between the wire and the liner thus reducing wire feedability

## 5.05 Welding Problems

	FAULT		CAUSE		REMEDY
1	Undercut.	A	Welding arc voltage too high.	A	Reduce voltage by reducing the voltage selection switch position or increase the wire feed speed.
		B	Incorrect torch angle	B	Adjust angle
		C	Excessive heat input	C	Increase the torch travel speed and/or reduce welding current by reducing the voltage selection switch position or reducing the wire feed speed.
2	Lack of penetration.	A	Welding current too low	A	Increase welding current by increasing wire feed speed and increasing voltage selection switch position.
		B	Joint preparation too narrow or gap too tight	B	Increase joint angle or gap
		C	Shielding gas incorrect	C	Change to a gas which gives higher penetration
3	Lack of fusion.		Voltage too low		Increase voltage by increasing voltage selection switch position.
4	Excessive spatter.	A	Voltage too high	A	Lower voltage by reducing the voltage selection switch or increase wirespeed control.
		B	Voltage too low	B	Raise voltage by increasing the voltage selection switch or reduce wirespeed control.
5	Irregular weld shape.	A	Incorrect voltage and current settings. Convex = voltage too low. Concave = voltage too high.	A	Adjust voltage and current by adjusting the voltage selection switch and the wirespeed control.
		B	Wire is wandering	B	Replace contact tip
		C	Incorrect shielding gas	C	Check shielding gas
		D	Insufficient or excessive heat input	D	Adjust the wirespeed control or the voltage selection switch

Table 5-1a: Welding Problems

FAULT		CAUSE		REMEDY	
6	Weld cracking	A	Weld beads too small	A	Decrease travel speed
		B	Weld penetration narrow and deep	B	Reduce current and voltage and increase MIG torch travel speed or select a lower penetration shielding gas.
		C	Excessive weld stresses	C	Increase weld metal strength or revise design
		D	Excessive voltage	D	Decrease voltage by reducing the voltage selection switch.
		E	Cooling rate too fast	E	Slow the cooling rate by preheating part to be welded or cool slowly.
7	Cold weld puddle	A	Faulty rectifier unit	A	Have an Accredited ESAB Service Agent to test then replace the faulty component.
		B	Loose welding cable connection.	B	Check all welding cable connections.
		C	Low Primary Voltage	C	Contact supply authority
8	Arc does not have a crisp sound that short arc exhibits when the wirefeed speed and voltage are adjusted correctly.		The MIG torch has been connected to the wrong voltage polarity on the front panel.		Connect the MIG torch to the positive (+) welding terminal for solid wires and gas shielded flux cored wires. Refer to the electrode wire manufacturer for the correct polarity.
9	Thermal overtemperature light illuminates during welding, but fan motor continues to run.		The machine duty cycle has been exceeded.		Allow the fan to run, to allow the machine to cool down.
10	Thermal overtemperature light illuminates in less than 30 seconds during welding		Fan has stopped running or fuse on PCB has blown.		Have an accredited ESAB Service Agent replace the fan motor or fuse.

This Page Intentionally Blank

**APPENDIX 1: OPTIONS AND ACCESSORIES**

- Contact your Firepower distributor to order options and accessories. For assistance in locating a Firepower distributor, contact the ESAB office listed in the inside rear cover that is nearest to you.
- Note the model and specification number shown on the equipment nameplate.

For Firepower/ESAB Inquiries and Orders:

Call 1-800-318-6819      Consumable Parts Management Group

Replacement Torch      Catalog number 1444-0741

## FEED ROLL INSTALLATION & CONSUMABLE GUIDE

### Wire Feed Rolls & MIG Gun Consumables

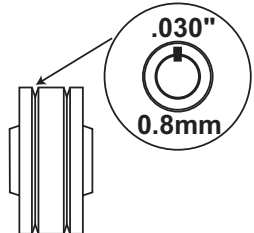

The branding size at the end of the feedroll refers to the size nearest to the mark.

Part No.	Description
1444-0427	Wire Feed Roll, Knurle, .023" - .030" / .035" (0.6-0.8mm/0.9mm), Hard/Cored
1444-0050	Nozzle
1444-0025	Contact Tip, .023" (0.6mm)
1444-0026	Contact Tip, .030" (0.8mm)
1444-0027	Contact Tip, .035" (0.9mm)
1444-0489	Gas Diffuser
1444-0741	MIG Gun, Complete Assembly

### Weld Wires

Part No.	Description
1444-0210	ER70S-6 Mild Steel Wire, .023" (0.6mm), 2 lbs. (0.9kg) Spool
1444-0211	ER70S-6 Mild Steel Wire, .023" (0.6mm), 11 lbs. (5kg) Spool
1444-0215	ER70S-6 Mild Steel Wire, .030" (0.8mm), 2 lbs. (0.9kg) Spool
1444-0216	ER70S-6 Mild Steel Wire, .030" (0.8mm), 11 lbs. (5kg) Spool
1444-0220	ER70S-6 Mild Steel Wire, .035" (0.9mm), 2 lbs. (0.9kg) Spool
1444-0221	ER70S-6 Mild Steel Wire, .035" (0.9mm), 11 lbs (5kg) Spool
1444-0230	E71T-GS Flux Cored Wire, .030" (0.8mm), 2 lbs (0.9kg) Spool
1444-0231	E71T-GS Flux Cored Wire, .030" (0.8mm), 10 lbs (4.5kg) Spool
1444-0235	E71T-GS Flux Cored Wire, .035" (0.9mm), 2 lbs (0.9kg) Spool
1444-0236	E71T-GS Flux Cored Wire, .035" (0.9mm), 10 lbs (4.5kg) Spool

Art # A-09026

Figure A-1: FP 125 Feed Roll and Consumables Chart

**APPENDIX 2: REPLACEMENT PARTS**

Item	DESCRIPTION	Model Part No.		
		FP 125	FP 135	FP 165
1	TORCH GROMMET	1444-0477	1444-0477	1444-0477
2	FRONT PANEL FP 125 SILK-SCREEN PRINTED	HELV05000348	HELV05000349	HELV05000350
3	PLASTIC HINGE FOR SIDE PANEL	1444-0435	1444-0435	1444-0435
4	SWITCH KNOB, FP 135/165	-	1444-0808	
5	POTENTIOMETER KNOB, FP 125/135/165	1444-0543	1444-0543	1444-0543
6	YELLOW PILOT-LIGHT SWITCH	1444-0440	1444-0440	1444-0440
7	RIGHT COVER PANEL FP 125-135-165	HELV05000354	HELV05000354	HELV05000354
8	FRONT FRAME, FP 125/135/165	1444-0833	1444-0833	1444-0833
9	CAP D.36 FOR MIG 100 LOUVER	1444-0831	1444-0831	1444-0831
10	INPUT POWER CABLE (Not Shown)	1444-0433	1444-0433	1444-0463
11	EARTH CLAMP, FP 125/135/165 (Not Shown)	1445-0966	1445-0966	1445-0966
12	EARTH CABLE, FP 125/135/165 (Not Shown)	1444-0843	1444-0843	1444-0843
13	LOUVER MIG 100	1444-0830	1444-0830	1444-0830
14	CABLE CLAMP FOR CABLE DIAM.6+ SCREW (Not Shown)	1444-0806	1444-0806	1444-0806
15	MIG GUN, FP 125/135/165 (Not Shown)	1444-0741	1444-0741	1444-0741
16	FEMALE CONNECTOR, 9/16"X18	-	1444-0839	1444-0839
17	GAS REGULATOR, FP 135/165	-	1444-0838	1444-0838
18	GAS HOSE 1,5M + CONN. 9/16" + CLAMPS	1444-0809	1444-0809	1444-0809
19	P.C. BOARD	1444-0483	1444-0483	1444-0465
20	MOTOR & GEARBOX, FP 135	-	1444-0803	W7004002
21	RECTIFIER	1444-0836	1444-0836	1444-0837
22	THERMOSTAT, RECTIFIER	1444-0456	1444-0456	1444-0443
23	FAN KIT	1444-0486	1444-0486	W7004008
24	CABLE CLAMP	1444-0807	1444-0807	1444-0428
25	PLASTIC FOOT	1444-0495	1444-0495	1444-0495
26	TRANSFORMER	1444-0844	1444-0462	1444-0469
27	CHOKE	1444-0846	1444-0847	1444-0728
28	SWITCH 17A	-	1444-0852	1444-0835
29	HOSE CONNECTOR D.4-HOSEHOLDER D.6 + NUTS	1444-0840	1444-0840	1444-0840
30	SPOOL HOLDER	1444-0800	1444-0800	1444-0800
31	MILD STEEL WIRE REEL	1444-0500	1444-0500	1444-0500
32	HANDLE, FP 125/135/165	1444-0828	1444-0828	1444-0828
33	WIRE FEEDER	1444-0848	1444-0850	1444-0491
34	WIRE FEED ROLL	-	1444-0427	1444-0427
34b	WIRE FEEDING D.28 + PINION	1444-0804	-	-
35	KIT GAS/NO GAS CHANGE BOARD	1444-0802	1444-0802	1444-0802
36	DIVIDING PANEL FP + LABELS	1444-0825	1444-0826	1444-0826
37	DOOR LATCH	1444-0426	1444-0426	1444-0426
38	LEFT SIDE PANEL FP SILK+LAB+HINGE+LOCK	HELV05000355	HELV05000356	HELV05000357
39	LOWER PANEL, FP 125/135/165	1444-0490	1444-0490	1444-0490
40	SWITCH 16A, FP 125	1444-0834	-	-
41	THERMOSTAT, XFMR	-	-	1444-0470
42	CONTACTOR (Not Shown)	1444-0498	1444-0498	-
43	BACK PANEL FP SILK-SCREEN PRINTED	HELV05000351	HELV05000352	HELV05000353

*Table A-1: FP 125 Replacement Parts List*

# FIREPOWER FP 125,135,165

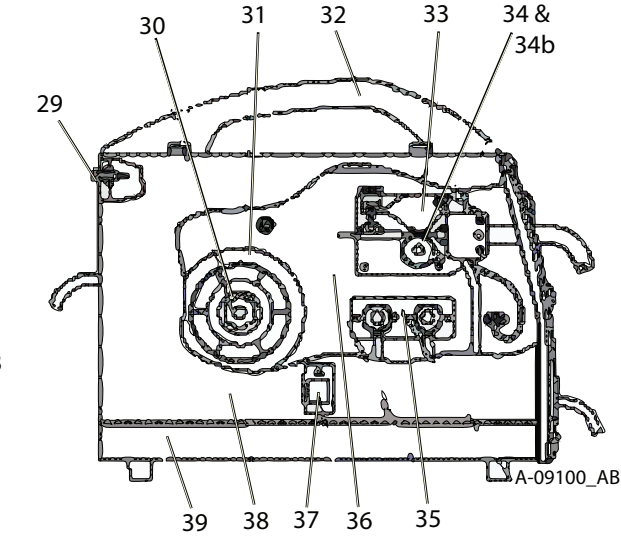
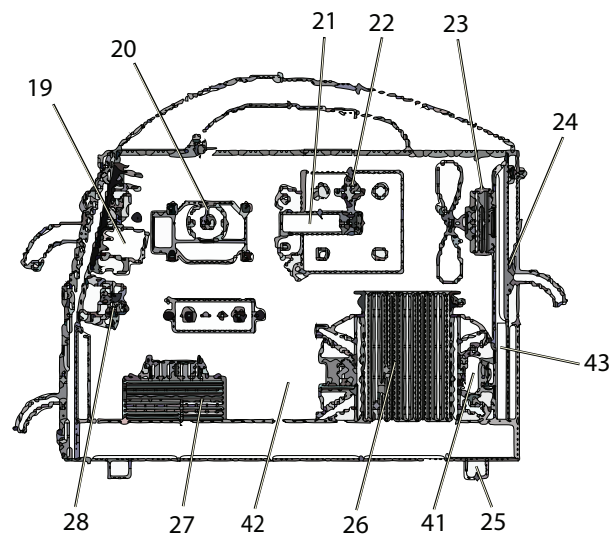
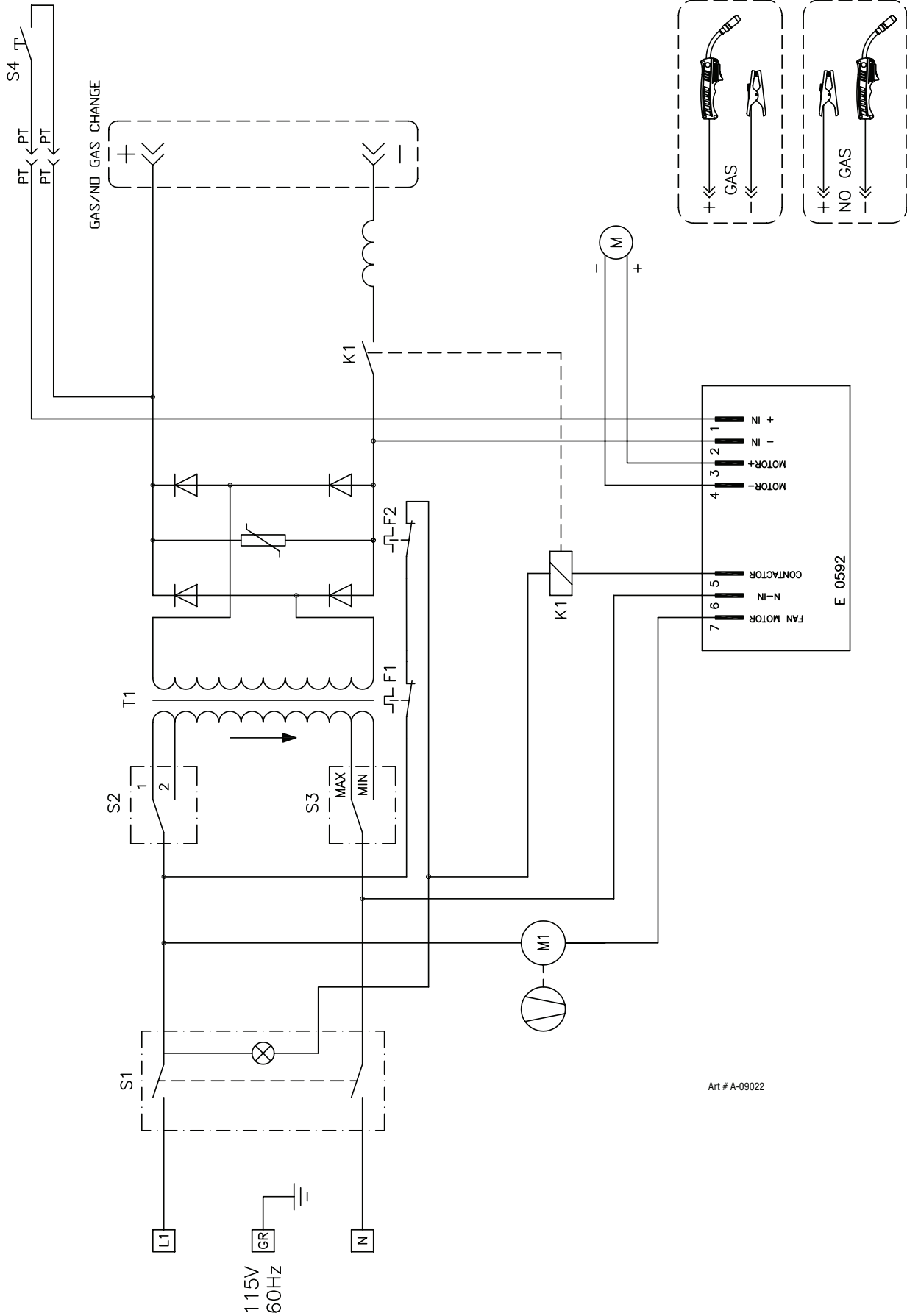

Figure A-4: FP 125-135-165 Replacement Parts Callout

**APPENDIX 3: FIREPOWER 125 SYSTEM SCHEMATIC**



Art # A-09022



**APPENDIX 5: FIREPOWER 165 SYSTEM SCHEMATIC**

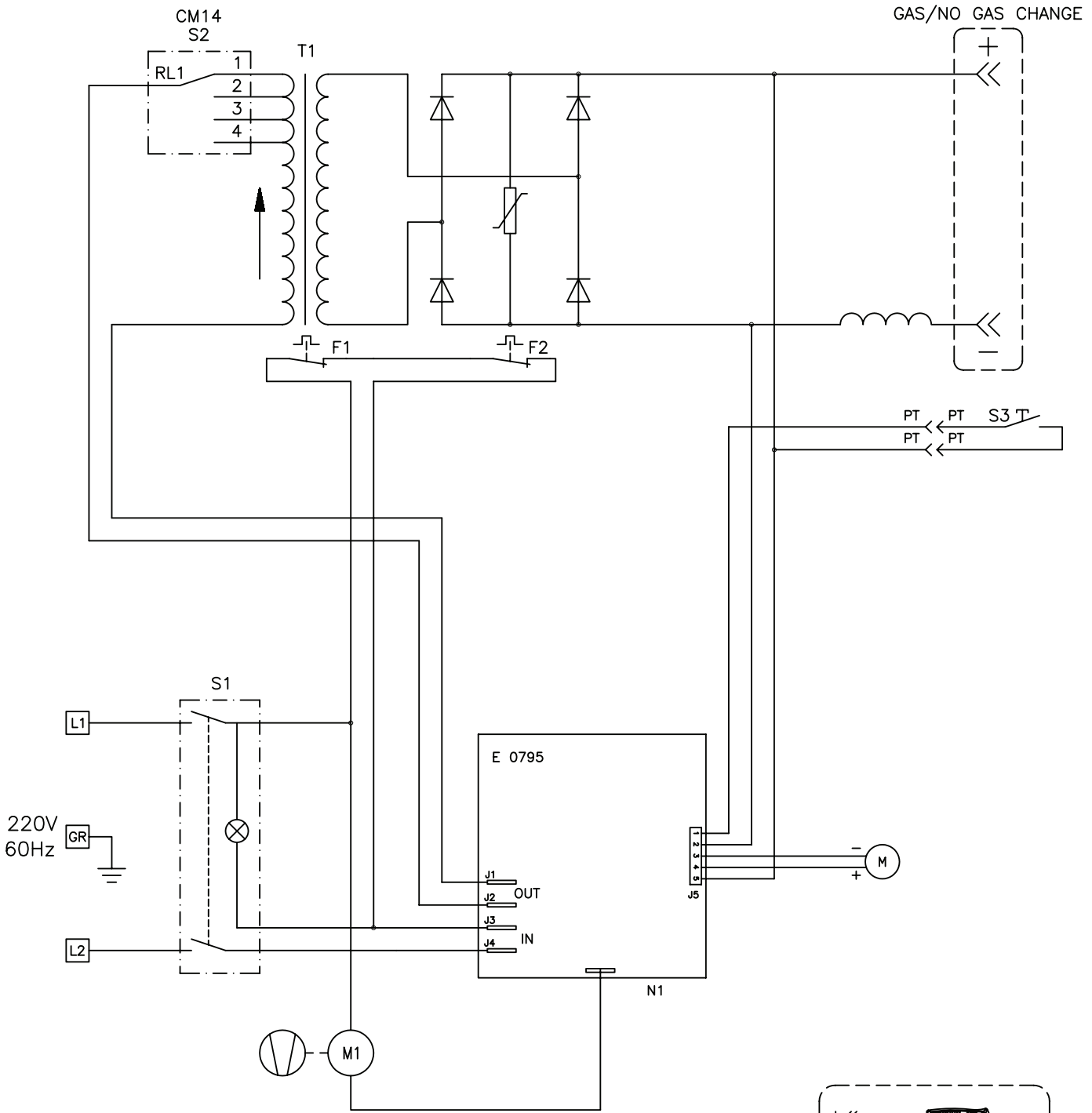

Art # A-09024

CM14

		RL1			
		1	2	3	4
POSITION	1	X			
	2		X		
	3			X	
	4				X

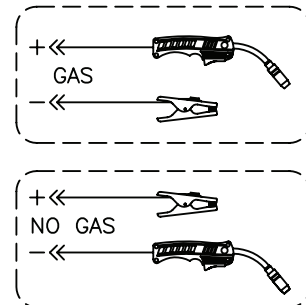

This Page Intentionally Blank

## **Revision History**

---

<b>Date</b>	<b>Rev</b>	<b>Description</b>
03/19/2009	AA	Manual release
10/16/2015	AB	Rebrand updates
04/06/2016	AC	Updated Appx part numbers.



# ESAB subsidiaries and representative offices

## Europe

### AUSTRIA

ESAB Ges.m.b.H  
Vienna-Liesing  
Tel: +43 1 888 25 11  
Fax: +43 1 888 25 11 85

### BELGIUM

S.A. ESAB N.V.  
Heist-op-den-Berg  
Tel: +32 70 233 075  
Fax: +32 15 257 944

### BULGARIA

ESAB Kft Representative Office  
Sofia  
Tel/Fax: +359 2 974 42 88

### THE CZECH REPUBLIC

ESAB VAMBERK s.r.o.  
Vamberk  
Tel: +420 2 819 40 885  
Fax: +420 2 819 40 120

### DENMARK

Aktieselskabet ESAB  
Herlev  
Tel: +45 36 30 01 11  
Fax: +45 36 30 40 03

### FINLAND

ESAB Oy  
Helsinki  
Tel: +358 9 547 761  
Fax: +358 9 547 77 71

### FRANCE

ESAB France S.A.  
Cergy Pontoise  
Tel: +33 1 30 75 55 00  
Fax: +33 1 30 75 55 24

### GERMANY

ESAB GmbH  
Solingen  
Tel: +49 212 298 0  
Fax: +49 212 298 218

### GREAT BRITAIN

ESAB Group (UK) Ltd  
Waltham Cross  
Tel: +44 1992 76 85 15  
Fax: +44 1992 71 58 03  
ESAB Automation Ltd  
Andover  
Tel: +44 1264 33 22 33  
Fax: +44 1264 33 20 74

### HUNGARY

ESAB Kft  
Budapest  
Tel: +36 1 20 44 182  
Fax: +36 1 20 44 186

### ITALY

ESAB Saldatura S.p.A.  
Bareggio (Mi)  
Tel: +39 02 97 96 8.1  
Fax: +39 02 97 96 87 01

### THE NETHERLANDS

ESAB Nederland B.V.  
Amersfoort  
Tel: +31 33 422 35 55  
Fax: +31 33 422 35 44

## NORWAY

AS ESAB  
Larvik  
Tel: +47 33 12 10 00  
Fax: +47 33 11 52 03

## POLAND

ESAB Sp.zo.o.  
Katowice  
Tel: +48 32 351 11 00  
Fax: +48 32 351 11 20

## PORTUGAL

ESAB Lda  
Lisbon  
Tel: +351 8 310 960  
Fax: +351 1 859 1277

## ROMANIA

ESAB Romania Trading SRL  
Bucharest  
Tel: +40 316 900 600  
Fax: +40 316 900 601

## RUSSIA

LLC ESAB  
Moscow  
Tel: +7 (495) 663 20 08  
Fax: +7 (495) 663 20 09

## SLOVAKIA

ESAB Slovakia s.r.o.  
Bratislava  
Tel: +421 7 44 88 24 26  
Fax: +421 7 44 88 87 41

## SPAIN

ESAB Ibérica S.A.  
Alcalá de Henares (MADRID)  
Tel: +34 91 878 3600  
Fax: +34 91 802 3461

## SWEDEN

ESAB Sverige AB  
Gothenburg  
Tel: +46 31 50 95 00  
Fax: +46 31 50 92 22  
ESAB international AB  
Gothenburg  
Tel: +46 31 50 90 00  
Fax: +46 31 50 93 60

## SWITZERLAND

ESAB AG  
Dietikon  
Tel: +41 1 741 25 25  
Fax: +41 1 740 30 55

## UKRAINE

ESAB Ukraine LLC  
Kiev  
Tel: +38 (044) 501 23 24  
Fax: +38 (044) 575 21 88

## North and South America

### ARGENTINA

CONARCO  
Buenos Aires  
Tel: +54 11 4 753 4039  
Fax: +54 11 4 753 6313

### BRAZIL

ESAB S.A.  
Contagem-MG  
Tel: +55 31 2191 4333  
Fax: +55 31 2191 4440

### CANADA

ESAB Group Canada Inc.  
Mississauga, Ontario  
Tel: +1 905 670 02 20  
Fax: +1 905 670 48 79

### MEXICO

ESAB Mexico S.A.  
Monterrey  
Tel: +52 8 350 5959  
Fax: +52 8 350 7554

### USA

ESAB Welding & Cutting Products  
Florence, SC  
Tel: +1 843 669 4411  
Fax: +1 843 664 5748

## Asia/Pacific

### AUSTRALIA

ESAB South Pacific  
Archerfield BC QLD 4108  
Tel: +61 1300 372 228  
Fax: +61 7 3711 2328

### CHINA

Shanghai ESAB A/P  
Shanghai  
Tel: +86 21 2326 3000  
Fax: +86 21 6566 6622

### INDIA

ESAB India Ltd  
Calcutta  
Tel: +91 33 478 45 17  
Fax: +91 33 468 18 80

### INDONESIA

P.T. ESABindo Pratama  
Jakarta  
Tel: +62 21 460 0188  
Fax: +62 21 461 2929

### JAPAN

ESAB Japan  
Tokyo  
Tel: +81 45 670 7073  
Fax: +81 45 670 7001

### MALAYSIA

ESAB (Malaysia) Snd Bhd  
USJ  
Tel: +603 8023 7835  
Fax: +603 8023 0225

### SINGAPORE

ESAB Asia/Pacific Pte Ltd  
Singapore  
Tel: +65 6861 43 22  
Fax: +65 6861 31 95

## SOUTH KOREA

ESAB SeAH Corporation  
Kyungnam  
Tel: +82 55 269 8170  
Fax: +82 55 289 8864

## UNITED ARAB EMIRATES

ESAB Middle East FZE  
Dubai  
Tel: +971 4 887 21 11  
Fax: +971 4 887 22 63

## Africa

### EGYPT

ESAB Egypt  
Dokki-Cairo  
Tel: +20 2 390 96 69  
Fax: +20 2 393 32 13

### SOUTH AFRICA

ESAB Africa Welding & Cutting  
Ltd  
Durbanville 7570 - Cape Town  
Tel: +27 (0)21 975 8924

### Distributors

For addresses and phone numbers to our distributors in other countries, please visit our home page  
[www.esab.com](http://www.esab.com)



[www.esab.com](http://www.esab.com)  
[www.firepoweronline.com](http://www.firepoweronline.com)