

OMEGALIFT™ EQUIPMENT

Engine Crane

Model
44020 (Retractable Legs)

Capacity
2 Ton

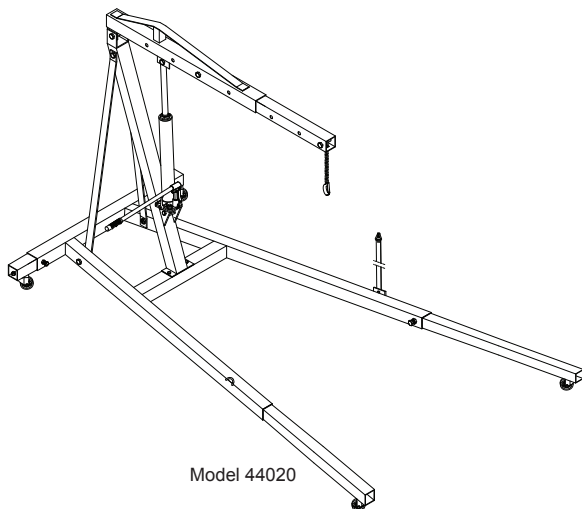

Model 44020



This is the safety alert symbol. It is used to alert you to potential personal injury hazards. Obey all safety messages that follow this symbol to avoid possible injury or death.

- ⚠ **WARNING:** Cancer and Reproductive Harm.
- ⚠ **AVERTISSEMENT:** Cancer et dommages au système reproducteur.
- ⚠ **ADVERTENCIA:** Cáncer y daño reproductivo.

www.P65Warnings.ca.gov

⚠WARNING



*To avoid crushing and related injuries:
NEVER work on, under or around a
load supported only by a hydraulic jack.
ALWAYS use a pair of adequately rated
jack stands.*

SFA Companies
<http://www.omegalift.com>

Read this manual and follow all the Safety Rules and Operating Instructions before using this product.

44020-M0_082018

SAFETY AND GENERAL INFORMATION

Save these instructions. For your safety, read, understand, and follow the information provided with and on this device before using. The owner and/or operator shall have an understanding of the device, its operating characteristics and safety operating instructions before operating the equipment. The owner and/or operator shall be aware that use and repair of this product may require special skills and knowledge. Instructions and safety information shall be read to and discussed with the operator in the operator's native language, making sure that the operator comprehends their contents, before use of this equipment is authorized. If any doubt exists as to the safe and proper use of this device, remove from service immediately.

Inspect before each use. Do not use if abnormal conditions such as cracked welds, damaged, loose or missing parts are noted. Any equipment that appears damaged in any way, is found to be worn, or operates abnormally shall be removed from service until repaired. If the equipment has been or is suspected to have been subjected to an abnormal load or shock, immediately discontinue use until inspected by a factory authorized repair facility (contact distributor or manufacturer for list of authorized repair facilities). It is recommended that an annual inspection be made by an authorized repair facility. Labels and Operator's Manuals are available from the manufacturer.

PRODUCT DESCRIPTION

This engine crane is intended to be used to remove, install and transport in the lowered position, rated capacity automotive and light truck engines and engine assemblies. It must be used with appropriately rated engine leveller, sling and/or chains which are NOT INCLUDED. After removing, immediately transfer the load to an appropriately rated work station such as an engine stand.

⚠ WARNING: *Do not use this device for any purpose other than described above.*

⚠ WARNING

- Study, understand, and follow all instructions before operating this device.
- Do not exceed rated capacity.
- Use only on hard, level surface capable of supporting the load.
- Before moving, lower the load to the lowest possible point.
- Use only slings or chains with a rated capacity greater than the weight of the load being lifted.
- Do not allow load to swing or drop violently while lowering or moving.
- No alterations shall be made on this product.
- Failure to heed these markings may result in personal injury and/or property damage.

⚠ WARNING

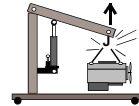

To avoid crushing and related injuries:

- NEVER work on, under or around a loaded crane.
- Immediately transfer the load to an appropriately rated engine stand.
- Be alert and sober when using this product! Never operate this equipment when under the influence of drugs or alcohol.
- DO NOT place yourself or anyone else over the loaded boom or in its line of travel.
- Use only hardened, appropriately sized fasteners to secure engine to crane.
- Use only chains and slings with a capacity equal to or greater than that of the crane.
- Never extend boom extension beyond leg extension (Model 44020).

SPECIFICATIONS

Model	Rated Capacity	Ram Hydraulic Stroke	Base Length	Base Width (Front)	Base Width (Rear)	Boom Position	Min. Hook Height	Max. Hook Height	Boom Length
44020	2 Ton	19"	61-3/4"~ 94-1/2"	31-1/2"~ 39"	27-3/8"~ 47-3/8"	2 Ton	18-1/8"	69-1/8"	45-1/4"
						1-1/2 Ton	13-3/8"	75"	54-1/2"
						1 Ton	9-1/4"	80-1/2"	63-3/8"
						1/2 Ton	4-1/8"	86"	72-1/4"

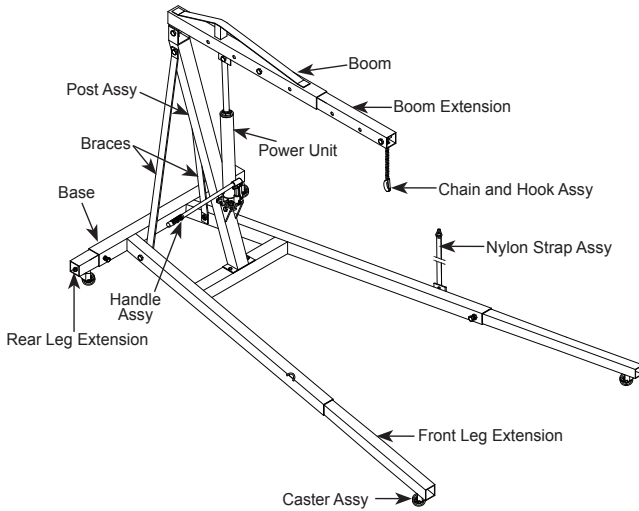

Figure 1 - Model 44020 Nomenclature

ASSEMBLY

Model 44020:

1. Make sure all parts listed in Figure 5 are present. If any parts are missing or damaged, contact customer service.
2. Assemble Swivel Casters Qty (4). Items: Caster Bracket (1), Wheel (2), Bolt (3), Pipe (4), Spring Washer (5), & Nut (6), tighten bolts.
3. Attach swivel caster assemblies to Rear Leg Extensions (7) and Front Leg Extensions (8) using Bolt (9) & Spring Washer (5), tighten bolts.
4. Slide Front Extension tubes & Rear Extension tubes, with Casters, into Base (10), secure with Bolts (11) into base, tighten bolts. Casters should rest on floor.

NOTICE: Never adjust leg extensions beyond factory marked position on each leg. Adjust each leg extension an equal distance from the base.

5. Place Post Assy (12) on the Base (10) and secure with Bolts (11). Leave bolts finger tight.
6. Attach Braces (13) on each side of upright at top and secure with Bolt & Nut (14 & 15). Place bottom of braces to inside of base, and secure with bolts & nuts (16 & 15). Tighten all bolts. Tighten Bolts (11) that were left finger tight.
7. Attach Power Unit Bracket (17) to Power Unit (18) with Bolts, Washers & Nuts (19, 20 & 21). Then attach the assembly to upright mounting ears using bolt & nut (22, 28 & 23).

8. Place Boom (24) on top of Post Assy (12) and secure with Bolt & Nut (25 & 26). Turn Power Unit Release Valve lever clockwise to close (Figure 3). Pump Power Unit using Handle (27) until ram extends approximately 2". Place boom mounting bracket on top of ram and secure with Bolt & Nut (28 & 23).

9. Slide Boom Extension (29) into the Boom (24), ensure the slot for chain faces down and secure with Bolt & Nut (28 & 23) in correct hole on boom for your particular job. Four positions available: 1/2 Ton, 1 Ton, 1 1/2 Ton And 2 Ton.

10. Slide Chain And Hook (30) through slot in lower front of Boom Extension (29) and secure with Bolt & Nut (31 & 15) as shown.

11. Attach Nylon Strap Assembly (32) to Base (10) with Bolt (33).

12. Retighten all fasteners.

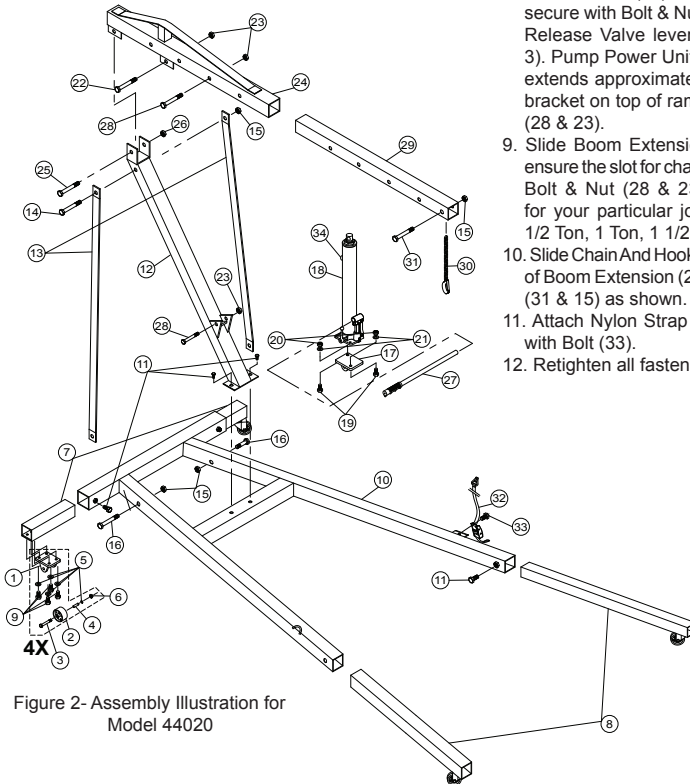

Figure 2- Assembly Illustration for Model 44020

BEFORE USE

1. Verify that the product and the application are compatible, if in doubt call Omega technical service (888) 332-6419.
2. Before using this product, read the operator's manual completely and familiarize yourself thoroughly with the product, its components and recognize the potential hazards associated with its use.
3. To familiarize yourself with basic operation, turn the release valve lever:
 - a. *Clockwise* until firm resistance is felt to further turning. This is the '**CLOSED**' release valve position used to raise the ram plunger.
 - b. *Counter-clockwise*, but no more than 2 turns from the closed position. This is the '**OPEN**' release valve position used to lower the ram plunger.

⚠ WARNING: *Clear all tools and personnel before lowering load. Open release valve slowly. The further handle is turned counter-clockwise, the faster the load will descend. Maintain control of the load at all times.*

4. Remove hydraulic unit and position as shown in figure 5.
5. With ram plunger fully retracted, remove the oil filler plug. Insert the handle into the handle sleeve, then pump 6 to 8 strokes. This will help release any pressurized air, which may be trapped within the reservoir. Ensure the oil level is just below the oil filler hole. Reinstall the oil filler plug.
6. Reinstall hydraulic unit.
7. Check to ensure that crane rolls freely and that the pump and release valve operate smoothly. Raise and lower the unloaded crane throughout the lifting range before putting into service. Replace worn or damaged parts and assemblies with Factory Authorized Replacement Parts only.

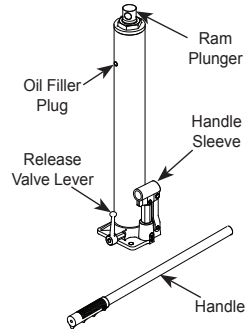

Figure 3 - Hydraulic Unit/ Ram

OPERATION

⚠ WARNING: *Use of this engine crane is limited to lifting, lowering, and transporting in the lowest possible position, automotive and light truck engines. It is NOT and should never be used as a work station.*

For model 44020:

The crane features length adjustable boom and length and width adjustable leg extensions. Extend both rear legs to an equal width. It is recommended that both rear legs be extended to the maximum allowable distance as limited by the marking on each leg. Both front leg extensions must be positioned to match the rated capacity markings on the booms. Both rear and front legs must be secured by means of a locking fastener found on each leg frame tube. Do not overtighten.

⚠ WARNING: *Front legs must be extended to equal length and match the rated capacity markings found on the boom. Never operate crane with boom and leg extensions positioned at different capacities (ref. Figure 6.)*

For All Models:

Always refer to vehicle service manual and/or shop manual for location of appropriate engine lift points and removal procedures. Each engine removal/installation may require different tools, procedures, and level of expertise.

⚠ WARNING: *Lift only on areas of the engine as specified by the vehicle manufacturer.*

⚠ WARNING: *Never load the crane with an engine that extends beyond an imaginary line drawn connecting the centerlines of the front and rear wheel/caster axles as shown in Figure 4.*

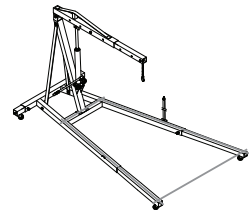

Figure 4

1. Ensure that the load does not exceed the rated capacity of your chosen boom and leg position.

2. Secure appropriately rated engine leveler, chain or sling assembly (sold separately) to the vehicle manufacturers' recommended engine lift points.
3. Secure the engine crane safety hook assembly to the engine leveler, chain or sling assembly.
4. Refer to vehicle service manual and/or shop manual for location of appropriate engine lift points and removal procedures. Each engine removal/installation may require different tools, procedures, and level of expertise.
5. When ready to remove engine, turn release valve clockwise until firm. Pump handle until load is high enough to clear vehicle. Before moving, ensure the load is:
 - a. at the lowest practical position and always below the center of gravity.
 - b. prevented from swinging and inadvertent shifting.

⚠ WARNING: *Never put any portion of your body under a load supported by the engine crane. Keep crane on hard, smooth, level surface Before moving crane, lower the boom as far below horizontal as possible, yet still allowing movement!*

6. Remove engine, then immediately transfer the engine to appropriate engine support device (engine stand). Turn release valve lever counter-clockwise to lower the load, but never more than 2 full turns. **Control** the rate of descent of the load **at all times**. The more you open the release valve, the faster the load descends.
7. Ensure stand is secure before working on or around.

MAINTENANCE

Periodically inspect the engine crane and fasteners. Replace worn or damaged parts with factory replacement parts only. Ensure caster, wheels, boom extension, leg extensions (if equipped) and pump assembly move freely.

NOTICE: *Use only good quality hydraulic jack oil. Avoid mixing different types of fluid and NEVER use brake fluid, turbine oil, transmission fluid, motor oil or glycerin. Improper fluid can cause premature failure of the jack and the potential for sudden and immediate loss of load. Premium hydraulic jack oil is recommended.*

Adding Oil to Hydraulic Unit

1. Remove hydraulic unit from crane.
2. With ram fully lowered and pump piston fully depressed, set hydraulic unit in its upright, level position. Remove oil filler plug.
3. Fill with oil until just below the rim of the oil filler plug hole. Reinstall the oil filler plug.

Changing Oil of Hydraulic Unit

For best performance and longest life, replace the complete fluid supply annually.

1. Carefully remove hydraulic unit from crane.
2. With ram fully lowered and pump piston fully depressed, remove oil filler plug.
3. Lay the hydraulic unit on its side and drain the fluid into a suitable container.

NOTICE: *Dispose of hydraulic fluid in accordance with local environmental regulations.*

4. Set hydraulic unit in its level upright position. Fill with oil until just below the rim of the oil filler hole. Reinstall the oil filler plug.

Lubrication

If rust appears, sand affected area and cover with suitable utility paint. A periodic coating of light lubricating oil to pivot points, axles and hinges will help to prevent rust and assure that wheels, casters, and pump assemblies move freely.

Cleaning

Periodically check the pump piston and ram for signs of rust or corrosion. Clean as needed and wipe with an oily cloth.

NOTICE: *Never use sandpaper or abrasive material on ram or pump piston surfaces.*

MAINTENANCE (cont.)

Storage

Store the engine crane with the pump piston, ram, and boom fully lowered and the release valve open, but never more than 2 full turns. This will help prevent rust and corrosion to those critical surfaces of hydraulic unit.

TROUBLESHOOTING

Symptom	Possible Causes	Corrective Action
Crane will not lift load	<ul style="list-style-type: none"> • Release valve not tightly closed • Overload condition 	<ul style="list-style-type: none"> • Ensure release valve tightly closed • Remedy overload condition
Crane will lift, but not maintain pressure	<ul style="list-style-type: none"> • Release valve not tightly closed • Hydraulic unit malfunction 	<ul style="list-style-type: none"> • Ensure release valve tightly closed • Contact Omega Tech. Service
Crane will not lower after unloading	<ul style="list-style-type: none"> • Reservoir overfilled 	<ul style="list-style-type: none"> • Ensure load is removed, then drain fluid to proper level
Poor lift performance	<ul style="list-style-type: none"> • Fluid level low • Air trapped in system 	<ul style="list-style-type: none"> • Ensure proper fluid level • With ram fully retracted, remove oil filler plug to let pressurized air escape, then reinstall oil filler plug
Crane will not lift to full extension	<ul style="list-style-type: none"> • Fluid level low 	<ul style="list-style-type: none"> • Ensure proper fluid level

ONE YEAR LIMITED WARRANTY

For a period of one (1) year from date of purchase, **SFA Companies** will repair or replace, at its option, without charge, any of its products which fails due to a defect in material or workmanship under normal usage. This limited warranty is a consumer's exclusive remedy.

Performance of any obligation under this warranty may be obtained by returning the warranted product, freight prepaid, to **SFA Companies** Warranty Service Department, 10939 N. Pomona Ave., Kansas City, MO 64153.

Except where such limitations and exclusions are specifically prohibited by applicable law, (1) THE CONSUMER'S SOLE AND EXCLUSIVE REMEDY SHALL BE THE REPAIR OR REPLACEMENT OF DEFECTIVE PRODUCTS AS DESCRIBED ABOVE. (2) **SFA Companies** SHALL NOT BE LIABLE FOR ANY CONSEQUENTIAL OR INCIDENTAL DAMAGE OR LOSS WHATSOEVER. (3) ANY IMPLIED WARRANTIES, INCLUDING WITHOUT LIMITATION THE IMPLIED WARRANTIES OF MERCHANTABILITY AND FITNESS FOR A PARTICULAR PURPOSE, SHALL BE LIMITED TO ONE YEAR, OTHERWISE THE REPAIR, REPLACEMENT OR REFUND AS PROVIDED UNDER THIS EXPRESS LIMITED WARRANTY IS THE EXCLUSIVE REMEDY OF THE CONSUMER, AND IS PROVIDED IN LIEU OF ALL OTHER WARRANTIES, EXPRESS OR IMPLIED. (4) ANY MODIFICATION, ALTERATION, ABUSE, UNAUTHORIZED SERVICE OR ORNAMENTAL DESIGN VOIDS THIS WARRANTY AND IS NOT COVERED BY THIS WARRANTY.

Some states do not allow limitations on how long an implied warranty lasts, so the above limitation may not apply to you. Some states do not allow the exclusion or limitation of incidental or consequential damages, so the above limitation or exclusion may not apply to you. This warranty gives you specific legal rights, and you may also have other rights, which vary from state to state.



SFA Companies
 10939 N. Pomona Ave. Kansas City, MO 64153, É.-U.
 Tél. : 1 888 332-6419 Téléc. : 1 816 891-6599
 Courriel : sales@omegalift.com
 Site Web Omega : <http://www.omegalift.com>

Model 44020

Item	Part No.	Description	Qty.
1	-	3 1/2 Caster Bracket	4
2	T474-04000-000-	3 1/2 Wheel	4
3*	-	HCS M8x60	4
4*	-	Pipe	4
5	-	Spring Washer 8mm	20
6	-	Nut M8	4
7*	T473-40000-100	Rear Leg Extension	2
8	T473-50000-000	Front Leg Extension	2
9	-	HCS M8x16	16
10	-	Base	1
11*	-	HCS M12x25	6
12	-	Post Assy	1
13	T473-00001-000	Braces	2
14*	-	HCS M12x100	1

Item	Part No.	Description	Qty.
15*	-	Nut M12	4
16	-	HCS M12x90	2
17	T473-00005-000	Power Unit Bracket	1
18	BL80-60000-000	Power Unit	1
19*	-	HCS M10x30	2
20*	-	Nut M10	2
21*	-	Spring Washer 10	2
22*	-	HCS M16x75	1
23*	-	Nut M16	3
24	-	Boom	1
25*	-	HCS M20x120	1
26*	-	Nut M20	1
27*	BL80-20000-000	Handle Assy	1
28*	-	HCS M16x90	2
29	T473-00006-000	Boom Extension	1
30	T473-05000-000	Chain and Hook Assy	1
31	-	HCS M12x75	1
32	-	Nylon Strap Assy	1
33	-	HCS M10x16	1
34	5905-00100-200	Oil Filler Plug	1
-	T473-60000-000	Hardware Kit	-
-	BL800S-034	Seal Kit, Hydraulic Unit	-
-	44020-L0	Label	-
-	44020-M0	Manual	-

* = Included in the Hardware Kit

If no part # is listed, this item is not available as a replacement part.

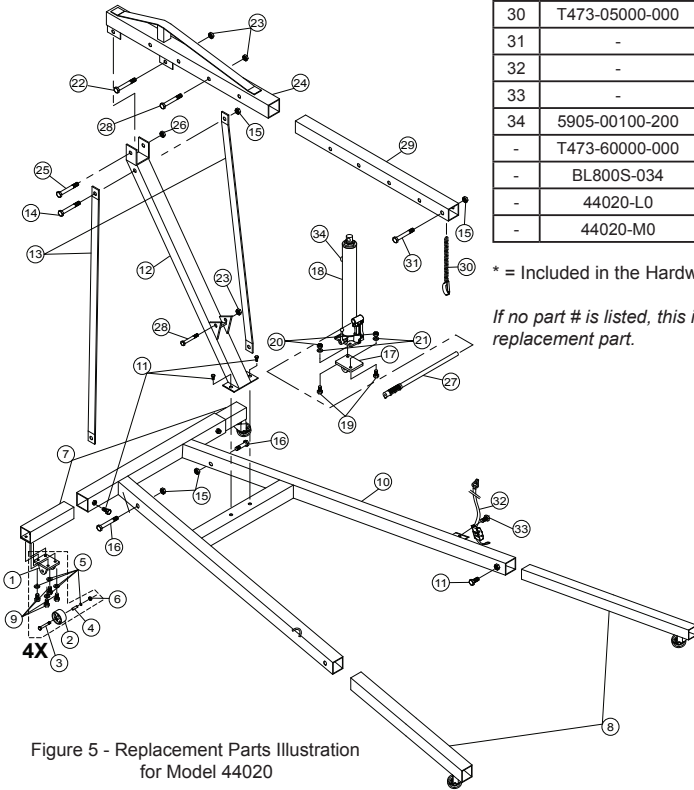

Figure 5 - Replacement Parts Illustration for Model 44020