

Operating Instructions and Parts Manual

Model
C-6036
C-6040
C-6048

Capacity
300 lbs
350 lbs
440 lbs

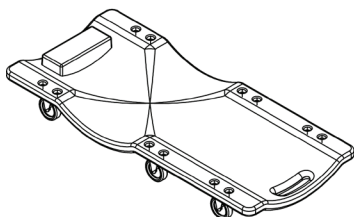

C-6036

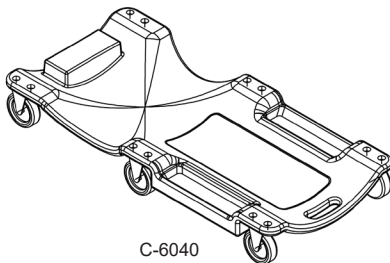

C-6040

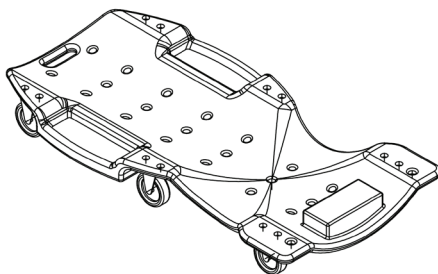

C-6048



This is the safety alert symbol. It is used to alert you to potential personal injury hazards. Obey all safety messages that follow this symbol to avoid possible injury or death.

⚠️WARNING

- Read, understand and follow the instructions before using the product.
- The operating manual and safety information should be communicated in the native language of the operator before use.
- Failure to do so may cause personal injury and or property damage.

⚠️ **WARNING:** Cancer and Reproductive Harm.

⚠️ **AVERTISSEMENT:** Cancer et dommages au système reproducteur.

⚠️ **ADVERTENCIA:** Cáncer y daño reproductivo.

www.P65Warnings.ca.gov

Read this manual and follow all the Safety Rules and Operating Instructions before using this product.

SAFETY AND GENERAL INFORMATION

For your safety, **read, understand, and follow** the information provided with and on this folding creeper. The owner and operator shall have an understanding of this product and safe operating procedures before attempting to use. The owner and operator shall be aware that use of this product may require special skills and knowledge. Instructions and safety information shall be conveyed in the operator's native language before use of this product is authorized. Make certain that the operator thoroughly understands the inherent dangers associated with the use and misuse of the product. If any doubt exists as to the safe and proper use of this product, remove from service immediately.

Inspect before each use. Do not use if there are broken, bent, cracked or damaged parts (including labels). Any creeper that appears damaged in any way, or operates abnormally shall be removed from service immediately. If the creeper has been subjected to a shock load (a load dropped suddenly, unexpectedly upon it), immediately discontinue use until it has been inspected by an Pro-Lift authorized service center. It is recommended that an annual inspection be done by qualified personnel. Labels and Operator's Manuals are available from manufacturer.

PRODUCT DESCRIPTION

These devices are designed to be used as a mechanics seat or used as a mechanics creeper. It is intended to be used to support and move, along a smooth and level surface capable of supporting rated capacity loads consisting of a single person weighing no more than ***300-440 lbs.** for the purpose of performing automotive maintenance or service. This device is not intended, designed or engineered to be used for any other purpose.

Rated Capacity: One (1) person weighing ***300-440 lbs. or less-** * includes person, tools, equipment, personal items

SPECIFICATIONS

Model	Rated Capacity	Seat Size	Creeper Size
C-6036	300 lbs	36" x 16"	36"
C-6040	350 lbs	40" x 19"	40"
C-6048	440 lbs	48" x 23 1/2"	48"



Do not use this device for any purpose other than that for which it is expressly intended.

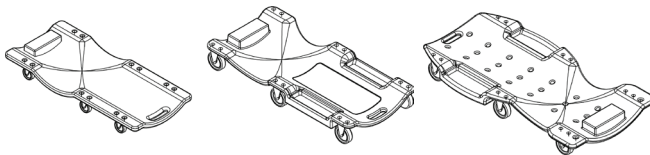

Figure 1 - Creeper Components

⚠ WARNING

To avoid personal injury and property damage:

- Read, understand, and follow all printed materials provided with and on this product before use.
- Do not exceed rated capacity! Rated capacity is 300-440 lbs. (includes user, tools, equipment and personal items).
- Sit down gently! Avoid shock loads caused by jumping or falling onto seat.
- Do not stand on product.
- Keep out of the reach of children! This device is not appropriate for children's use.
- Use only on hard, level surface capable of supporting the load.

PREPARATION

Before assembling your Creeper, make sure all parts are present. If any part is missing or damaged, do not attempt to assemble or use the product. Contact Pro-Lift customer service for replacement parts.

Part	Description	Qty
1	Base	1
2	Swivel Caster	6
3	Carriage Bolt	12
4	Bushing	12
5	Washer	12
6	Lock Nut	12

ASSEMBLY INSTRUCTIONS

- Working from the underside of the Base, align a Swivel Caster with one of the six pairs of holes on the Base.
- Place a bushing in each hole, then insert two Carriage Bolts through the Caster, the Bushing and the Base from underneath.
- Secure in place with the Washers and Lock Nuts.
- Repeat for each of the other Swivel Casters.
- Check that all the Lock Nuts are securely tightened.

REPLACEMENT PARTS

Not all components of the creepers are replacement items, but are illustrated as a convenient reference of location and position in the assembly sequence. When ordering parts, give model number, part number and description below. For product labels and owners manual, call or write: SFA Companies 10939 N. Pomona Ave. Kansas City, MO 64153, U.S.A. Tel: (888) 332-6419 Fax: (816) 891-6599; Website: www.ProLiftProducts.com; Email: sales@ProLiftProducts.com

OPERATING INSTRUCTIONS

- Position the Plastic Creeper on the ground near the area of intended work.
- Sit slowly on the end of the creeper, avoid shock loading the product.
- Lay back and rest your head on the provided headrest.
- Using you feet position yourself in order to perform intended work.

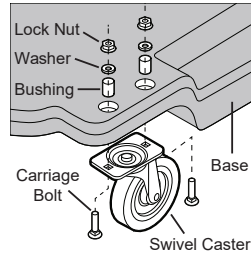

Figure 2 - General assembly of a single caster

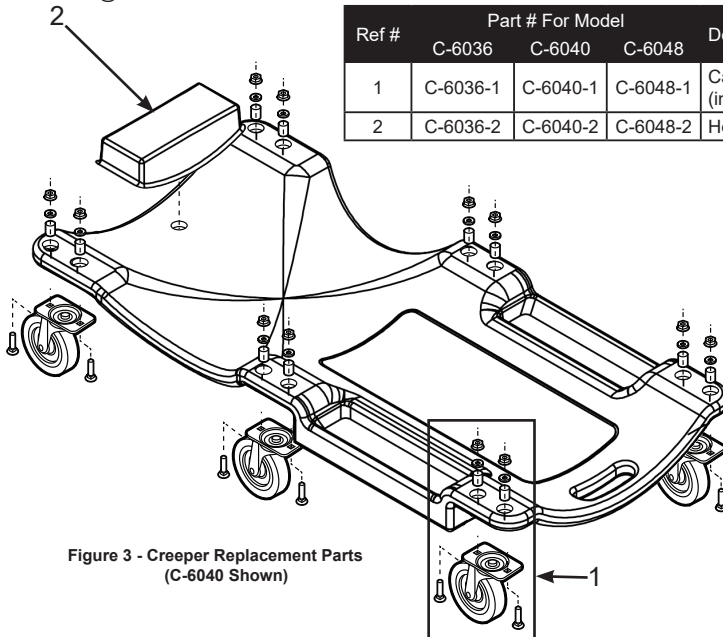

Figure 3 - Creeper Replacement Parts (C-6040 Shown)

Ref #	Part # For Model			Description	Qty
	C-6036	C-6040	C-6048		
1	C-6036-1	C-6040-1	C-6048-1	Caster Assembly (includes hardware)	6
2	C-6036-2	C-6040-2	C-6048-2	Head Cushion	1

ONE YEAR LIMITED WARRANTY

For a period of one (1) year from date of purchase, **SFA Companies** will repair or replace, at its option, without charge, any of its products, which fails due to a defect in material or workmanship under normal usage. This limited warranty is a consumer's exclusive remedy.

Performance of any obligation under this warranty may be obtained by returning the warranted product, freight prepaid, to **SFA Companies** Warranty Service Department, 10939 N. Pomona Ave., Kansas City, MO 64153.

Except where such limitations and exclusions are specifically prohibited by applicable law, (1) THE CONSUMER'S SOLE AND EXCLUSIVE REMEDY SHALL BE THE REPAIR OR REPLACEMENT OF DEFECTIVE PRODUCTS AS DESCRIBED ABOVE. (2) **SFA Companies** SHALL NOT BE LIABLE FOR ANY CONSEQUENTIAL OR INCIDENTAL DAMAGE OR LOSS WHATSOEVER. (3) ANY IMPLIED WARRANTIES, INCLUDING WITHOUT LIMITATION THE IMPLIED WARRANTIES OF MERCHANTABILITY AND FITNESS FOR A PARTICULAR PURPOSE, SHALL BE LIMITED TO ONE YEAR, OTHERWISE THE REPAIR, REPLACEMENT OR REFUND AS PROVIDED UNDER THIS EXPRESS LIMITED WARRANTY IS THE EXCLUSIVE REMEDY OF THE CONSUMER, AND IS PROVIDED IN LIEU OF ALL OTHER WARRANTIES, EXPRESS OR IMPLIED. (4) ANY MODIFICATION, ALTERATION, ABUSE, UNAUTHORIZED SERVICE OR ORNAMENTAL DESIGN VOIDS THIS WARRANTY AND IS NOT COVERED BY THIS WARRANTY.

Some states do not allow limitations on how long an implied warranty lasts, so the above limitation may not apply to you. Some states do not allow the exclusion or limitation of incidental or consequential damages, so the above limitation or exclusion may not apply to you. This warranty gives you specific legal rights, and you may also have other rights, which vary from state to state.

PRO-LIFT®

SFA Companies, Inc.
10939 N. Pomona Ave.
Kansas City, MO 64153
Phone (888)332-6419, Fax (816)891-6599