



1000-LB. TRANSMISSION JACK

OWNER'S MANUAL



WARNING:

Read carefully and understand all **ASSEMBLY AND OPERATION INSTRUCTIONS** before operating. Failure to follow the safety rules and other basic safety precautions may result in serious personal injury.

Item# 111948

Thank you very much for choosing a Strongway product! For future reference, please complete the owner's record below:

Model: _____ Purchase Date: _____

Save the receipt, warranty and these instructions. It is important that you read the entire manual to become familiar with this product before you begin using it.

This machine is designed for certain applications only. The distributor cannot be responsible for issues arising from modification. We strongly recommend this machine not be modified and/or used for any application other than that for which it was designed. If you have any questions relative to a particular application, DO NOT use the machine until you have first contacted the distributor to determine if it can or should be performed on the product.

For technical questions please call **1-800-222-5381**.

INTENDED USE

This 1000-LB. transmission Jack for is designed for transmission installation and removal. Universal mounting head provides a wide fore and aft tilt range. Manual operated hydraulic system that includes a bypass system to prevent over-extension and accidental overloading. Low profile design; four heavy-duty steel swivel casters provide easy maneuvering throughout the shop. Fits most transmissions. This product is tested for reliability and safety to meet ASME PALD Standards.

TECHNICAL SPECIFICATIONS

	Description
Item	46192
Capacity	1000 lbs.
Lifting Range	48-7/16 inch ~ 65-3/4 inch
Saddle Forward Tilt	5 °
Saddle Backward Tilt	8 °
Saddle Rightward Tilt	5 °
Saddle Leftward Tilt	8 °
Base L x W	22-1/4 x 21-3/8 inch

Safe Operating Temperature is between 40°F –105°F (4°C –41°C)

GENERAL SAFETY RULES



WARNING: Read and understand all instructions. Failure to follow all instructions listed below may result in serious injury.



CAUTION: Do not allow persons to operate or assemble this Jack until they have read this manual and have developed a thorough understanding of how the Jack works.



WARNING: The warnings, cautions, and instructions discussed in this instruction manual cannot cover all possible conditions or situations that could occur. It must be understood by the operator that common sense and caution are factors that cannot be built into this product, but must be supplied by the operator.

SAVE THESE INSTRUCTIONS

IMPORTANT SAFETY CONSIDERATIONS

JACK USE AND CARE

- **Do not modify the Jack in any way.** Unauthorized modification may impair the function and/or safety and could affect the life of the equipment. There are specific applications for which the **Jack** was designed.
- **Always check of damaged or worn out parts before using the Jack.** Broken parts will affect the **Jack** operation. Replace or repair damaged or worn parts immediately.
- **Store idle Jack.** When **Jack** is not in use, store it in a secure place out of the reach of children. Inspect it for good working condition prior to storage and before re-use.
- **Not for use by children** or people with reduced mental capacity.
- **Do not use under the influence of drugs or alcohol.**
- **Ensure children and other bystanders** are kept at a safe distance when using crane.

INSPECTION

- Inspect the jack carefully before each use. Ensure the jack is not damaged, excessively worn, or missing parts.
- Do not use the jack unless it is properly lubricated.
- Using a jack that is not in good clean working condition or properly lubricated may cause serious injury.
- Inspect the work area before each use. Make sure it is free and clear of any potential hazards.

DO NOT OPERATE OR REPAIR THIS EQUIPMENT WITHOUT READING THIS MANUAL.

To maintain the Transmission Jack and user safety, the owner is responsible for reading and following these instructions.

- Inspect the service jack for proper operation and function.
- Keep instructions readily available for equipment operators. Make certain all equipment operators are properly trained; understand how to safely and correctly operate the unit.
- Allow unit operation only with all parts in place and operating properly.
- Use only genuine replacement parts. Service and maintain the unit only with authorized or approved replacement parts negligence will make the jack unsafe for use and void the warranty.
- Carefully inspect the unit on a regular basis and perform all maintenance as required.
- Store these instructions in the handle of your jack. Keep all decals on the unit clean and visible.
- Safety: always follow safety precautions when installing and operating this jack.
- Before proceeding ensure that you fully understand and comprehend the full contents of this manual.
- Failure to operate this equipment as directed may cause injury or death.
- The distributor is not responsible for any damages or injury caused by improper use or neglect

Always use Jack Stands!

DO NOT USE wood blocks or any other non-approved load sustaining devices. The manufacturer only warrants loads to be sustained by jack stands that meet current ASME standards.

DO NOT USE wood blocks or any other non-approved lifting device for a means of lifting with the jack and or load being raised. Failure to heed these warnings may cause injury or death.



WARNING:

1. Study, understand, and follow all instructions before operating this device.
2. Do not exceed rated capacity.
3. Use only on hard, level surfaces.
4. Adequately support the vehicle before starting repairs.
5. Use of this product is limited to the removal, installation, and transportation in the lowered position, of transmissions, transfer cases, and transaxles.
6. No alterations shall be made to this product.
7. Only attachments and/or adapters supplied by the manufacturer shall be used.
8. Do not use this jack for any use other than the manufacturer specified usage.
9. Failure to heed these markings may result in personal injury and/or property damage.

GENERAL SAFETY INSTRUCTIONS

* Position the Jack

Position the jack to only lift on the areas of the vehicle as specified by the vehicle manufacturer.

* Always Use Jack Stands

After lifting the vehicle always support the load with appropriately rated vehicle Jacks stands before working on the vehicle.

* Do Not Overload Jack

Do not overload this jack beyond its rated capacity. Overloading this jack beyond its rated capacity can cause damage to or failure of the jack.

* Always Use on Hard Level Surfaces

This jack is designed only for use on hard level surfaces capable of sustaining the load. Use on unstable or other possible loss of load.

* Chock and Block (Stabilize)

-Apply parking brake in vehicle before operating jack. A chock is a wedge for steadying an object and holding it motionless, or for preventing the movement of a wheel

-Chock the wheel opposite the end being lifted.

-When you block a load, you secure and support a load that is being lifted. The block(s) or stabilizer(s) should have a weight capacity that is greater than the weight of the load which is being lifted.

* Center Load on Jack Saddle

Center the load on jack saddle before lifting vehicle.

Off-center loads and loads lifted when the jack is not level can cause loss of load or damage to the jack.

*Do not raise or lower the vehicle unless tools, materials and people are clear.

When the lift is being lowered, make sure everyone is standing at least six feet away. Be sure there are no tools or equipment left under or around the jack before lowering.

* Always lower the jack slowly.



WARNING:

DO NOT USE THE JACK TO SUPPORT OR STABILIZE A LOAD.

Using the jack to support or stabilize a load may result in unexpected movement and result in serious injury, being crushed and death. Always securely chock and block (stabilize) the load to be lifted.

Never place any part of the body under a raised load without properly chocking and supporting the load.

* Never use the jack on curved or tubular vehicle

Bumpers, this will result in the vehicle slipping off the jack and falling, causing serious injury or death.

Use a bumper lift for vehicles with curved bumpers or plastic bumpers.

* Wear ANSI-approved safety glasses and heavy-duty work gloves during use.

* Do not adjust the safety valve.

* Do not move or dolly vehicle while jack is in use.

* **Stay alert. Use caution and common sense when operating jack.** Do not use a jack if you are tired, incoherent, dizzy, or under the use of drugs or alcohol.

Training

-Read this manual before use. Do not allow anyone who has not read this manual, and/or does not understand the requirements, to use the jack.

Spectators

-Do not allow bystanders around the jack or under the load supported only by the jack. Do not allow anyone in the vehicle while the jack is in use. Keep all bystanders away from vehicle when in use.

Inspection

-Inspect the jack carefully before each use. Ensure the jack is not damaged, excessively worn, or missing parts. -Do not use the jack unless it is properly lubricated. -Using a jack that is not in good clean working condition or properly lubricated may cause serious injury.

Additional Notes:

Save the receipt, warranty and these instructions.

Do not modify the jack in any way. Unauthorized modification may impair the function and/or safety and could affect the life of the equipment. There are specific applications for which the jack was designed.

Always check for damaged or worn out parts before using the jack. Broken parts will affect the equipment operation. Replace or repair damaged or worn parts immediately.

When jack is not in use, store it in a secure place out of the reach of children. Inspect it for good working condition prior to storage and before re-use.

ASSEMBLY

All numbers in parenthesis () refer to the index number from the parts breakdown.

1. Attach the four ball bearing caster wheels to the 4 respective legs of the jack bases, making sure to tighten the screw.

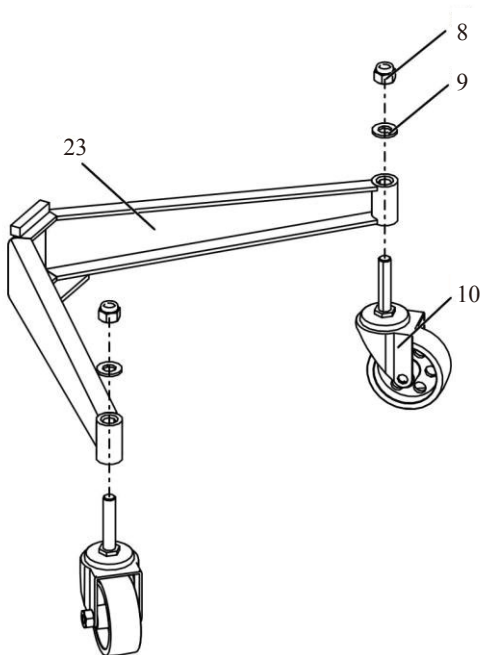

2. Attach the bases (23) to the support tube parts (22) with screws (7), washers (11), spring washers (12) and nuts (13).

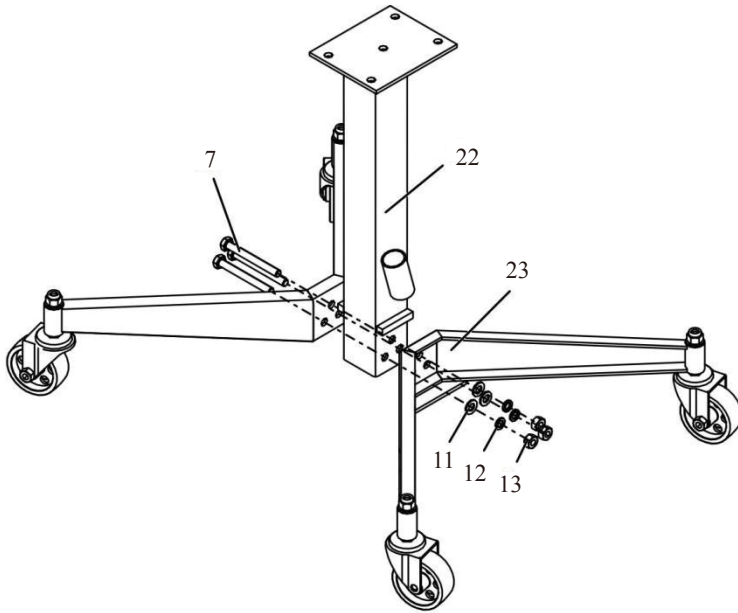

3. Attach the long ram jack (20) to the support tube parts (22) with screws (21), washers (11), spring washers (12) and nuts (13).

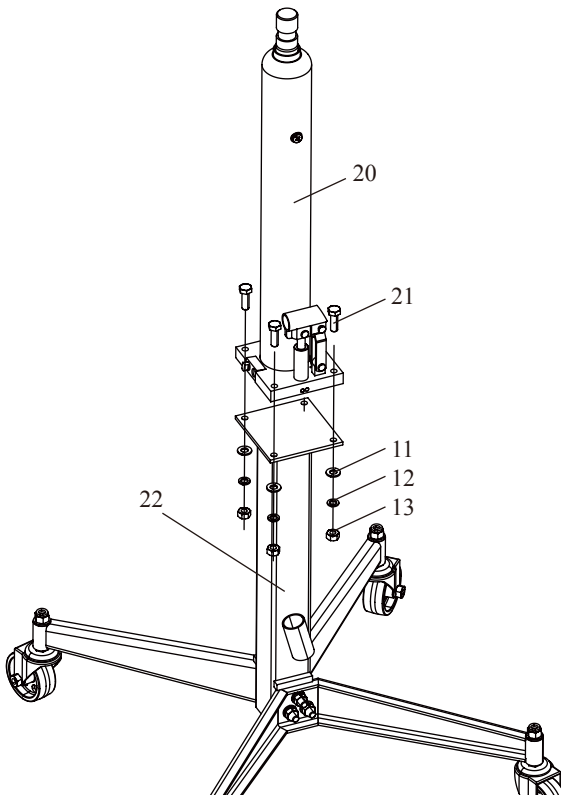

4. Attach the saddle to the jack with screw (14).

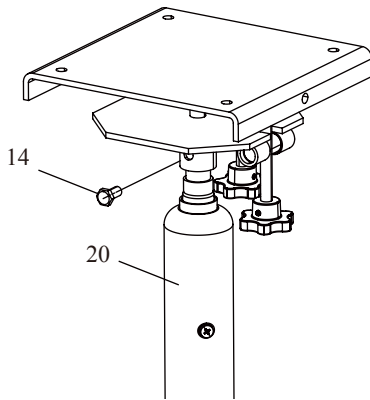

5. Mount the four angle brackets (T4) to the saddle using screws (T5), washers (T6), spring washers (T7) and nuts (T8). Attach the hook guide (3) to the saddle with washer (11), spring washer (12) and nut (13) and assemble the chain hook-to-hook guide (3) with two screws (1) and washers (2). And then tighten screw (16) through the chain to the saddle with washers (2), spring washers (2) and nuts (1).

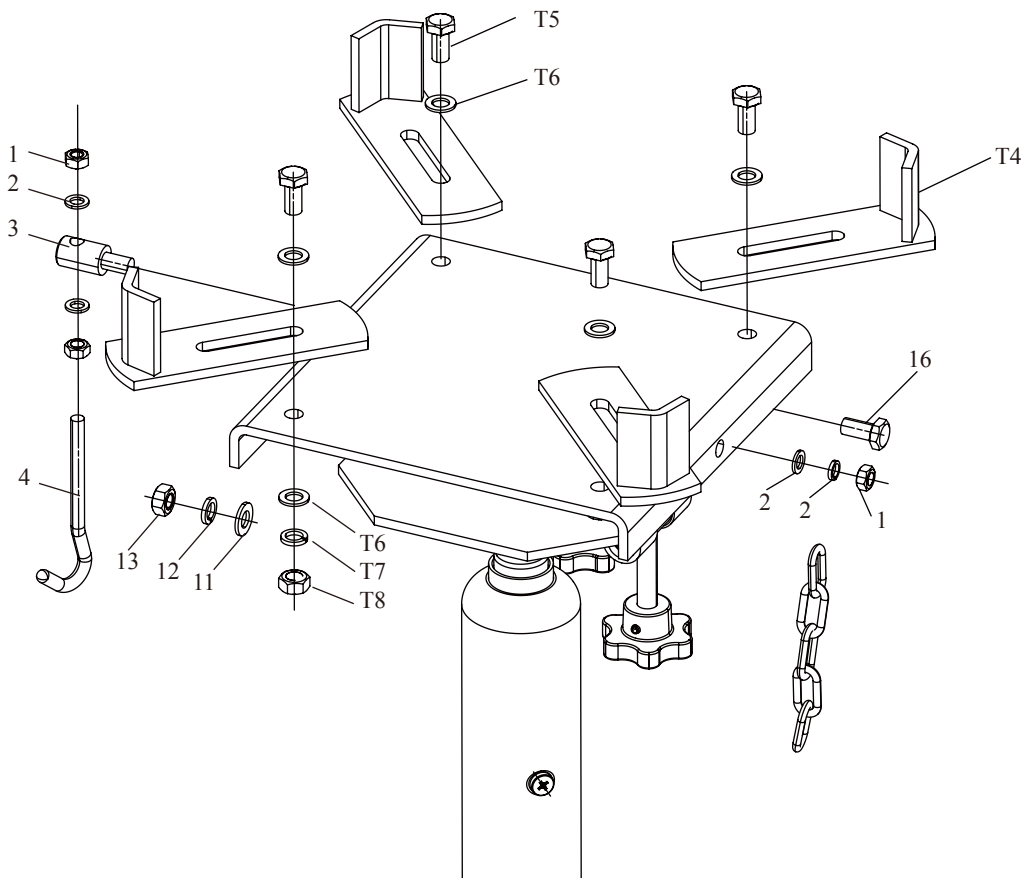

SYSTEM AIR PURGE PROCEDURE

IMPORTANT: BEFORE FIRST USE

All numbers in parenthesis () refer to the index number from the parts breakdown.

Perform the following Air Purge Procedure to remove any air that may have been introduced into the hydraulic system as a result of product shipment and handing. This step is to be completed without any weight on the jack.

1. Turn release valve (27) counterclockwise one full turn to the open position.

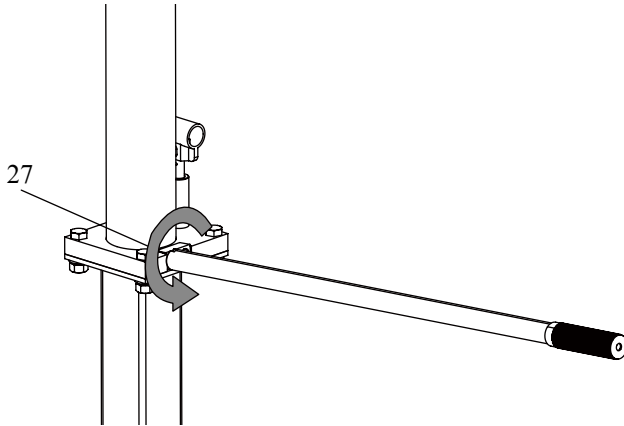

2. Pump handle (6) eight full strokes.

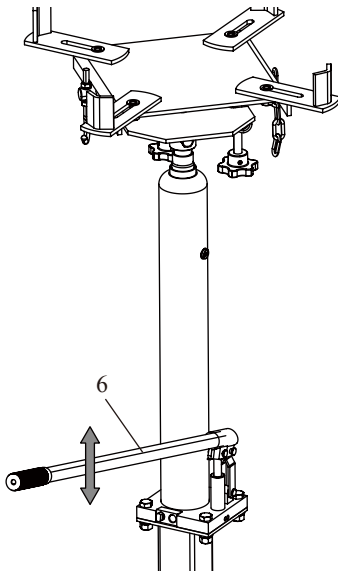

3. Turn release valve (27) clockwise to the closed position.

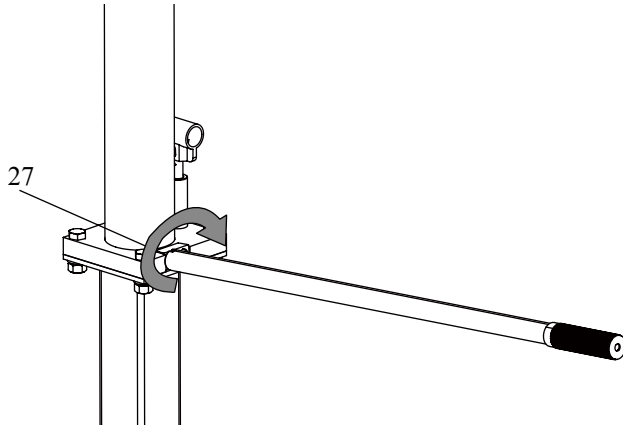

4. Pump handle (6) until the ram reaches about half height; continue to pump several times to remove trapped air in the ram.

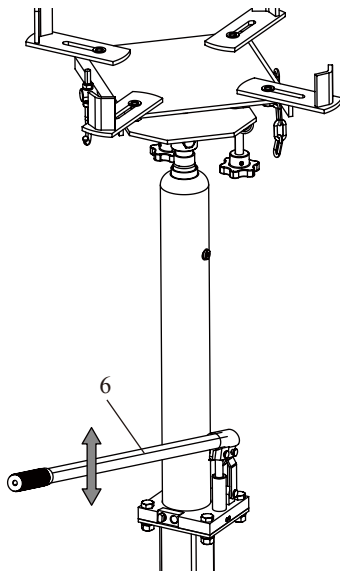

- Carefully and slowly pinch oil fill plug to release trapped air.

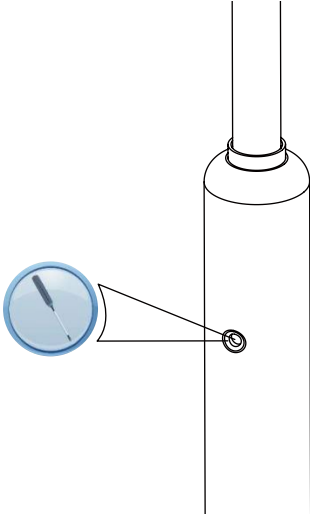

- Turn release valve (27) counterclockwise to the open position one full turn and lower ram to the lowest position.

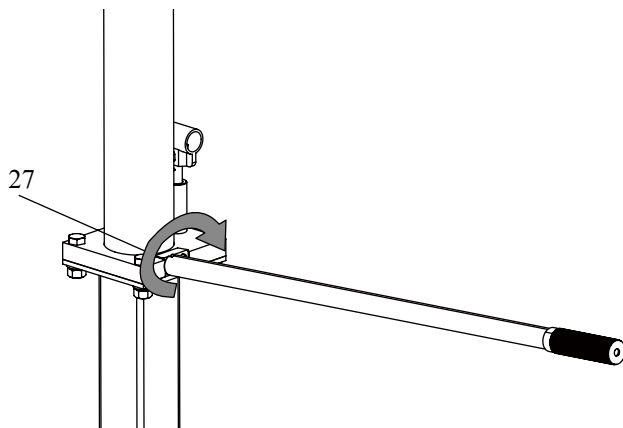

7. Turn release valve clockwise to the closed position and check for proper pump action. It may be necessary to perform the above step more than once to assume air is completely evacuated.

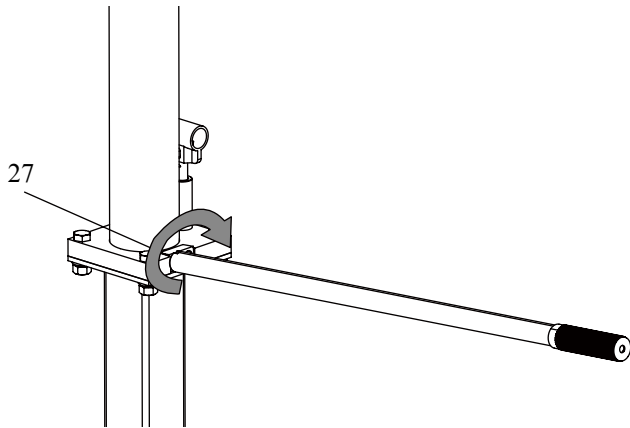

BEFORE USE

1. Before using this product, read the owner's manual completely and familiarize yourself thoroughly with the product and the hazards associated with its improper use.
2. Perform the air purge procedure. (See previous instructions for system purge procedure.)
3. Inspect your jack before each use. Do not use if bent, broken or cracked components are noted.

OPERATION

All numbers in parenthesis () refer to the index number from the parts breakdown.

RAISING THE JACK

1. Before use, ensure the transmission weight and size does not exceed the capacity of the jack.
2. Ensure the vehicle from which the gearbox is to be removed is correctly positioned,
3. Check to ensure the handbrake is applied and raised to allow the transmission jack to be positioned correctly.
4. Ensure there are no other persons around or under the vehicle.
5. Ensure saddle is in its lowest position and use handle to transport and centrally position jack beneath vehicle transmission.
6. Close the release valve by turning it clockwise until it is firmly closed.
7. Pump handle to lift until saddle contacts load. Continue to pump the jack handle to lift the vehicle to the desired height.
8. After lifting, support the load with appropriately before removing transmission.

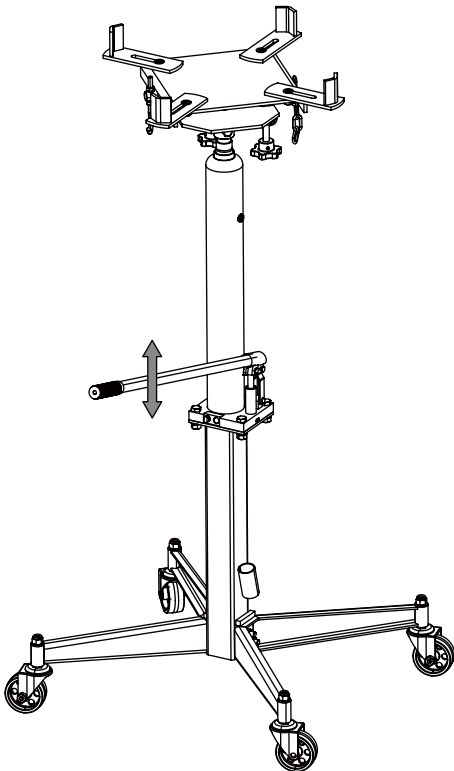

LOWERING THE JACK

1. Ensure the load is supported before removing transmission. Check to make sure the transmission is stable on the jack saddle and load is fixed in place before attempting to lift lower, or transport.
2. Grasp the handle firmly with both hands. Securely hold on to the jack handle so your hands do not slip and ensure the release valve does not rapidly lower.
3. Carefully open the Release Valve by slowly turning the handle counterclockwise. (Do not allow bystanders around the jack or under the load when lowering the jack).
4. Lower saddle to the lowest minimum height before attempting to transport load.

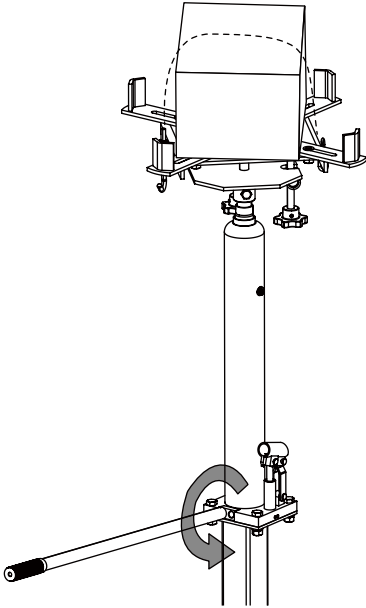

TRANSPORTING THE LOAD

1. Ensure the jack saddle is fully lowered and load is secure before attempting to lift, lower, or transport transmission.
2. Transport the load over level and solid ground, preferably concrete, and ensure the floor is swept clean before transporting load.
3. Be diligent in continually monitoring the load in transit. Keep all other persons at a safe distance.
4. DO NOT use this jack on asphalt, or any soft surface as jack may sink or tip, causing damage to transmission; personal or injury/harm may result.

 **WARNING:**

5. **If jack tips or leans STOP WHAT YOU ARE DOING. MOVE QUICKLY TO A SAFE DISTANCE. DO NOT TRY TO HOLD OR STEADY JACK** to prevent personal injury and/or property damage.

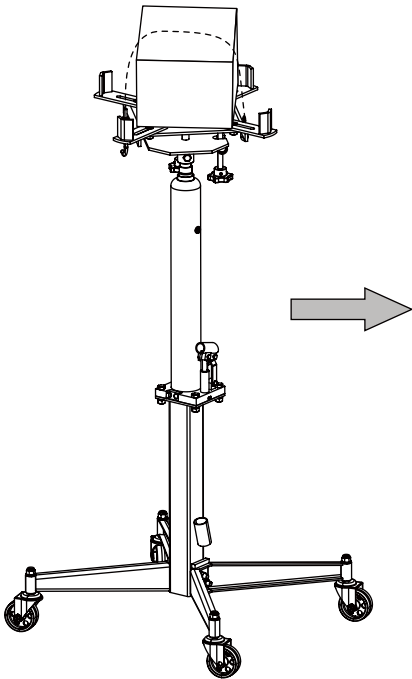

RE-INSTALLING A GEARBOX

1. Ensure the jack saddle is fully lowered and load is secure before attempting to lift or transport transmission.
2. Transport the load over level and solid ground, preferably concrete, and ensure the floor is swept clean before transporting load.
3. Be diligent in continually monitoring the load in transit. Keep all other persons at a safe distance.
4. DO NOT use on asphalt, or any soft surface as jack may sink or tip, causing damage to transmission or personal or injury/harm may result.
5. **If jack tips or leans STOP WHAT YOU ARE DOING. MOVE QUICKLY TO A SAFE DISTANCE. DO NOT TRY TO HOLD OR STEADY JACK.**
6. Raise load to desired height.

 **WARNING:**

7. Use caution when re-installing transmission load can shift causing personal injury and/or property damage

MAINTENANCE INSTRUCTIONS

If you use and maintain your equipment properly, it will give you many years of service. Follow the maintenance instructions carefully to keep your equipment in good working condition. Never perform any maintenance on the equipment while it is under a load.

Inspection

You should inspect the product for damage, wear, broken or missing parts (e.g.: pins) and that all components function before each use. Follow lubrication and storage instructions for optimum product performance.

Binding

If the product binds while under a load, use equipment with equal or a larger load capacity to lower the load safely to the ground. After un-binding; clean, lubricate and test that equipment is working properly. Rusty components, dirt, or worn parts can be causes of binding. Clean and lubricate the equipment as indicated in the lubrication section. Test the equipment by lifting without a load. If the binding continues, contact Customer Service.

Cleaning

If the moving parts of the equipment are obstructed, use cleaning solvent or another good degreaser to clean the equipment. Remove any existing rust, with a penetrating lubricant.

Lubrication

This equipment will not operate safely without proper lubrication. Using the equipment without proper lubrication will result in poor performance and damage to the equipment. Some parts in this equipment are not self-lubricating inspect the equipment before use and lubricate when necessary. After cleaning, lubricate the equipment using light penetrating oil, lubricating spray.

-Use a good lubricant on all moving parts.

-For light duty use lubrication once a month.

-For heavy and constant use lubrication recommended every week.

-NEVER USE SANDPAPER OR ABRASIVE MATERIAL ON THESE SURFACES!

Rust Prevention:

-Check ram's and pump plungers on the power unit assemblies daily for any signs of rust or corrosion.

Without a load, lift the equipment as high as it goes and look under and behind the lifting points. If signs of rust are visible, clean as needed.

How the Jack Operates

With release valve closed, an upward stroke of the jack handle draws oil from the reservoir tank into the plunger cavity. Hydraulic pressure holds the valve closed, which keeps the oil in the plunger cavity. A downward stroke of the jack handle releases oil into the cylinder, which forces the ram out. This raises the saddle. When the ram reaches maximum extension, oil is bypassed back into the reservoir to prevent an over extended ram stroke and possible damage to the jack. Opening the release valve allows oil to flow back into reservoir. This releases hydraulic pressure on the ram, which results in lowering the saddle.

Storing the Jack

1. Lower the Lifting Arm.
2. Place the handle in the upright position.
3. Store in a dry location, recommended indoors.

Note: If the jack is stored outdoors, be sure to lubricate all parts before and after use to ensure the jack stays in good working condition.

TO ADD JACK OIL:

The hydraulic cylinder assembly contains hydraulic fluid that must be kept at approximately 80% full at all times for proper operation. To check the level and to fill remove oil filler plug.

1. Position the jack on level ground and lower the saddle in the upright position. Open release valve by turning handle counter-clockwise (4 full turns).
2. Locate and remove oil filler plug.

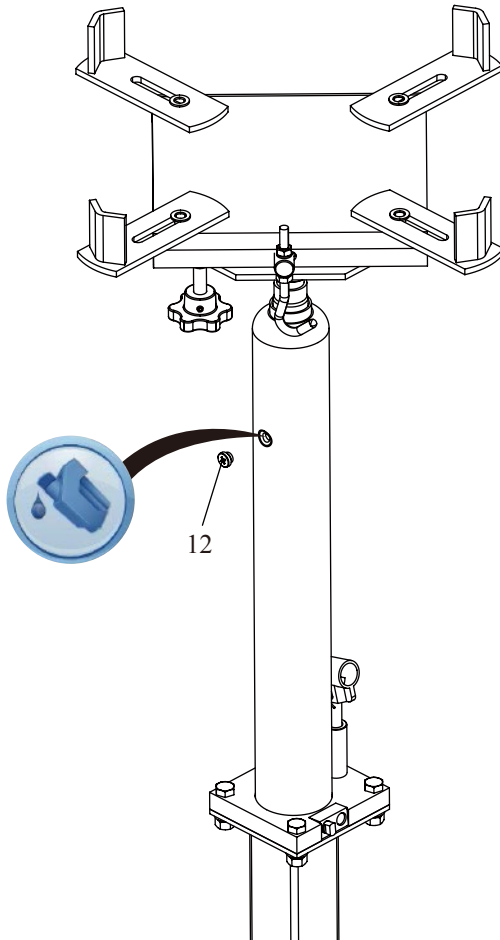

3. Fill the oil case until oil level is just beneath the lower rim of the oil fill hole.
4. Replace oil plug.
5. Perform the Air Purge Procedure.

TO REPLACE JACK OIL:

1. Position the jack on level ground and lower the saddle in the upright position.
2. Open release valve by turning handle counter-clockwise (4 full turns).

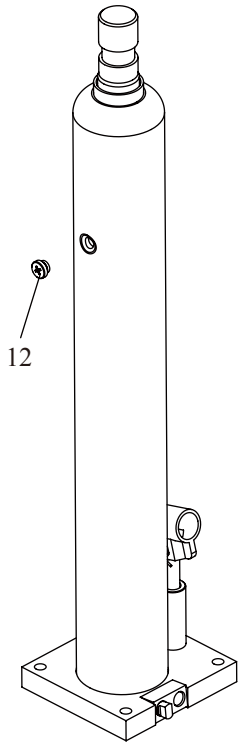

3. Lay the jack on its side and drain the fluid into a suitable container.
- Note: Dispose of hydraulic fluid in accordance with local regulations.

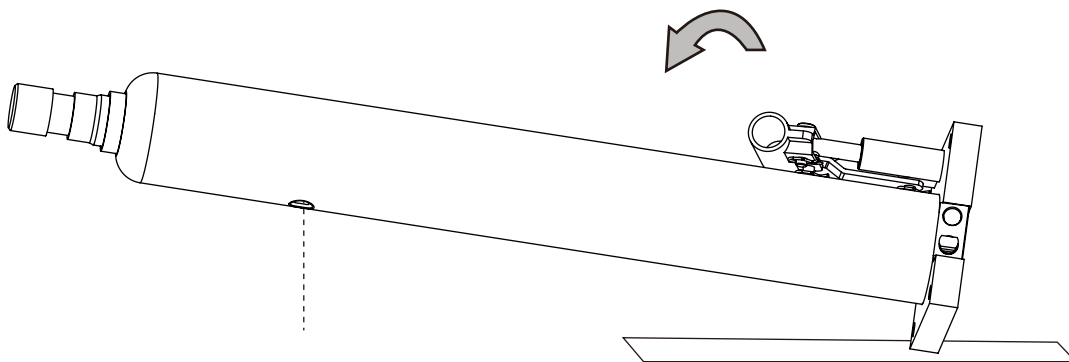

4. Position the jack on level ground.

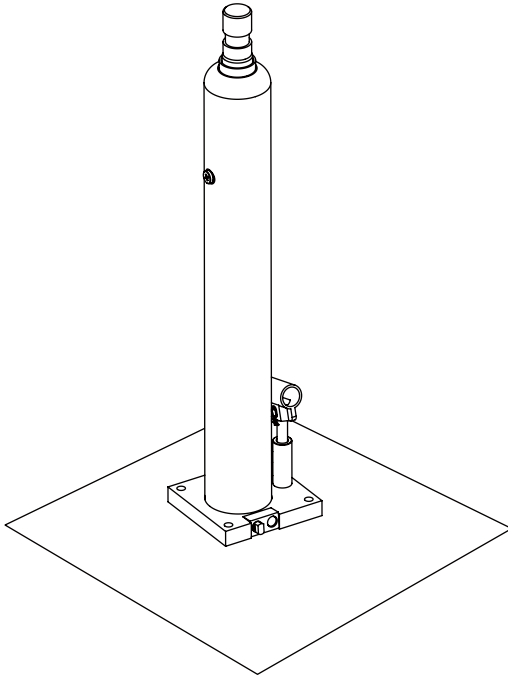

5. Fill the oil case until oil level is just beneath the lower rim of the oil fill hole.
KEEP DIRT AND OTHER MATERIAL CLEAR WHEN POURING.
6. Replace oil plug.
7. Perform the Air Purge Procedure.



ADDITIONAL WARNINGS:

- DO NOT USE MOTOR OIL IN THE JACK.
- ONLY USE ANTI-FOAMING JACK OIL.
- ALWAYS USE A GOOD GRADE HYDRAULIC JACK OIL.
- DO NOT USE HYDRAULIC BRAKE FLUID, ALCOHOL, GLYCERINE, DETERGENT, MOTOR OIL OR DIRTY OIL.
- USE OF A NON-RECOMMENDED FLUID CAN CAUSE DAMAGE TO A JACK.
- AVOID MIXING DIFFERENT TYPES OF FLUID AND NEVER USE BRAKE FLUID, TURBINE OIL, TRANSMISSION FLUID, MOTOR OIL OR GLYCERIN. IMPROPER FLUID CAN CAUSE PREMATURE FAILURE OF THE JACK AND THE POTENTIAL FOR SUDDEN AND IMMEDIATE LOSS OF LOAD.
- DISPOSE OF HYDRAULIC FLUID IN ACCORDANCE WITH LOCAL REGULATIONS.

Important: Use only a quality grade hydraulic jack oil. Avoid mixing different types of fluid and NEVER use brake fluid, turbine oil, transmission fluid, motor oil or glycerin. Improper fluid can cause failure of the jack and the potential for sudden and immediate loss of load.

LUBRICATION

A periodic coating of light lubricating oil to pivot will help to ensure that pump piston linkages move freely.

Note: Never apply oil to the saddle. If saddle extension threads require lubrication; clean thread surfaces with a clean, dry cloth, then apply a drop of bearing grease. Distribute as evenly as possible along the threaded post.

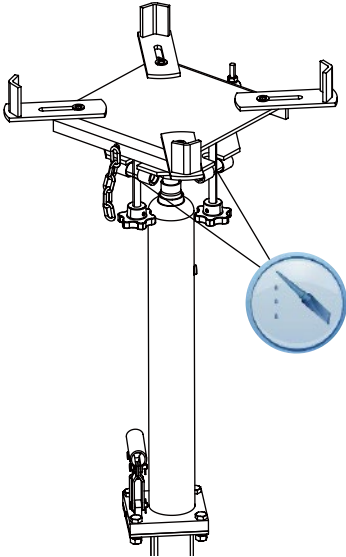

1. A coating of light lubricating oil to pivot points. Axles and hinges will help to prevent rust and assure that wheels, casters and pump assemblies move freely.
2. Periodically check the pump piston and ram for signs of rust or corrosion. Clean as needed and wipe with an oil cloth.
3. When not in use, store the Jack with pump piston and ram fully retracted.

TROUBLESHOOTING

JACK WILL NOT LIFT LOAD	JACK WILL NOT HOLD LOAD	JACK WILL NOT LOWER	POOR JACK LIFTING	WILL NOT LIFT TO FULL EXTENSION	CAUSES AND SOLUTIONS
X	X		X		Release valve is not completely closed (Turn handle clockwise).
X					Weight Capacity Exceeded.
X			X		Air is in the hydraulics. Purge air from system.
X	X		X	X	Low oil level. Add oil as required.
		X			Oil reservoir is overfilled: Drain excessive oil. Lubricate moving parts.
		X			Jack is binding or foreign obstruction
X	X		X		Power unit malfunctioning. Replace the power unit.

ASSEMBLY DIAGRAM

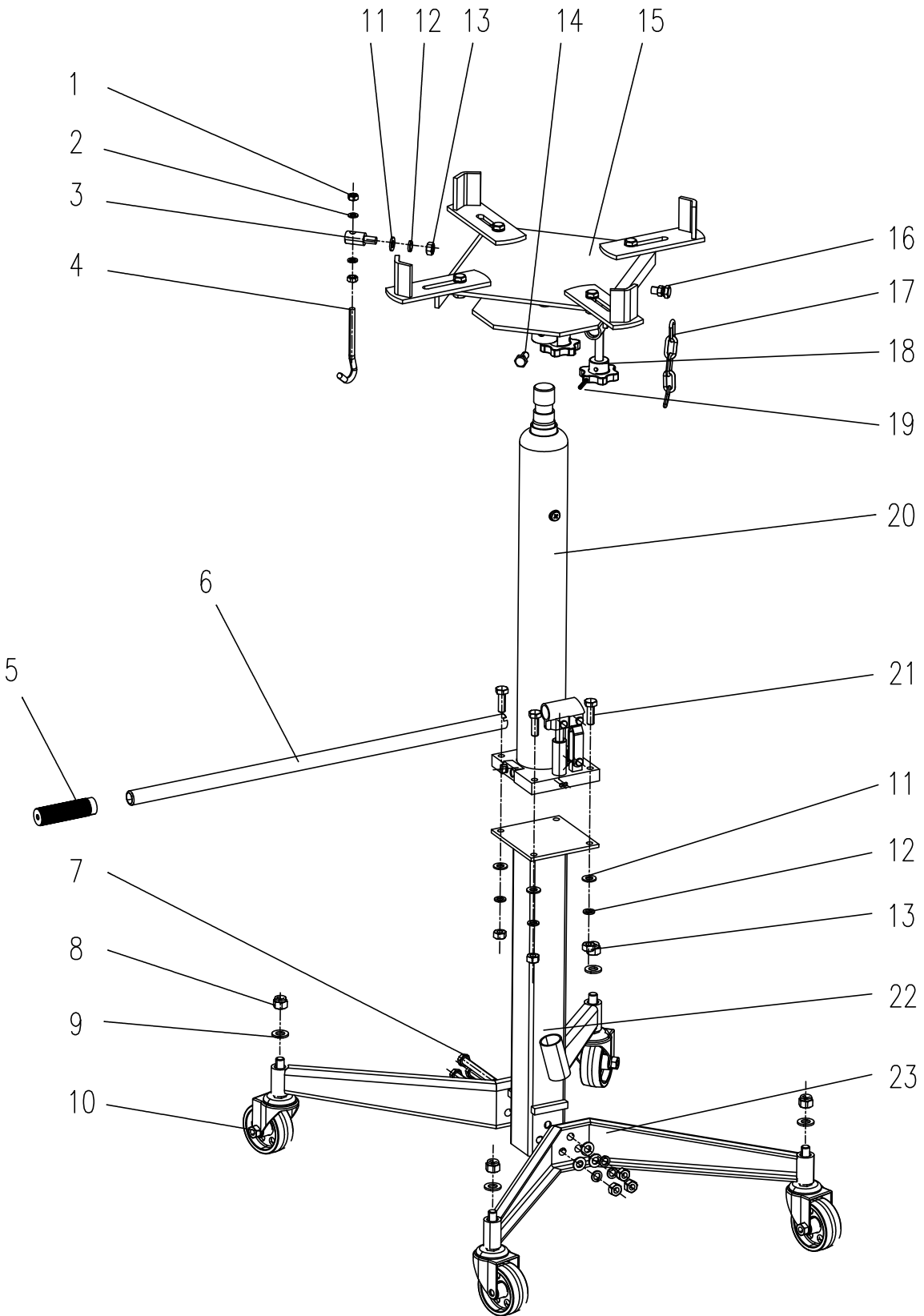

ASSEMBLY PARTS LIST

Index #	Description	Part No.	Qty.
1	Nut M8	GB/T 6710	3
2	Washer 8	GB/T 97.1	4
3	Hook pin	TE10001-03	1
4	Hook	TE10001-02	1
5	Handle sleeve	T32002C-2	1
6	Handle	T30808-23	1
7	Blot M10×90	GB/T 5782	3
8	Nut M12	GB/T 889	4
9	Washer 12	GB/T 97.1	4
10	Wheel parts	TEL05001.3	4
11	Washer 8	GB/T 97.1	4
12	Spring washer 8	GB/T 93	5
13	Nut M8	GB/T 6710	4
14	Blot M10×20mm	GB/T 5780	1
15	Platform assembly	TEL05001.4	1
16	Blot M8×30mm	GB/T 5780	1
17	Chain	TEL05001-02	1
18	Handwheel	TEL05001-03	2
19	Spring pin Ø5x30mm	GB/T 879	2
20	Long ram jack	TEL05001H.1	1
21	Blot M8×40mm	GB/T 5780	4
22	Suporting tube assembly	TEL05001H.2	1
23	Suporting leg assembly	TEL05001H.3	2

SADDLE ASSEMBLY DIAGRAM

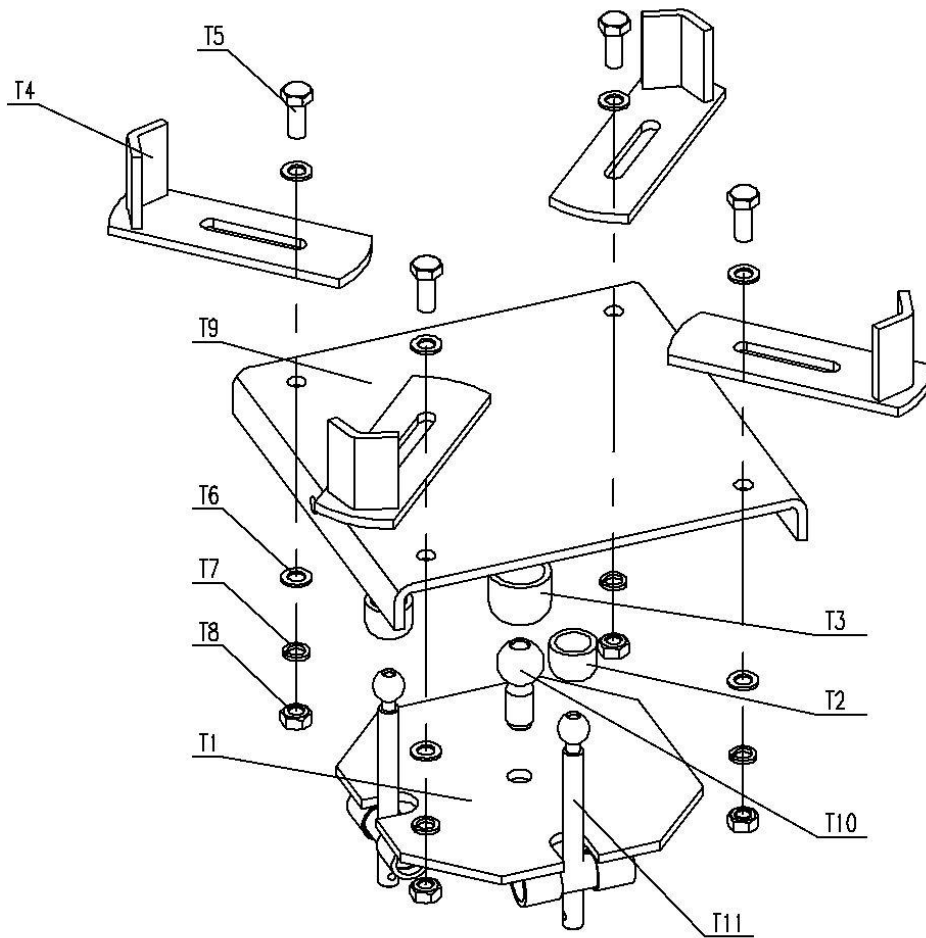

SADDLE ASSEMBLY PARTS LIST

Index #	Description	Part No.	Qty.
T1	Adjustment board	TEL05001.4.1	1
T2	Ball base 1	TEL05001.4-01	2
T3	Ball base 2	TEL05001.4-02	1
T4	Skateboard parts	TEL05001.4.2	4
T5	Screw M10x30	GB5781	4
T6	Washer 10	GB97.1	8
T7	Spring Washer 10	GB93	4
T8	Nut M10	GB6170	4
T9	Saddle panel	TEL05001.4-03	1
T10	Rod parts	TEL05001.4.3	1
T11	Screw parts	TEL05001.4.4	2

LONG RAM JACK ASSEMBLY DIAGRAM

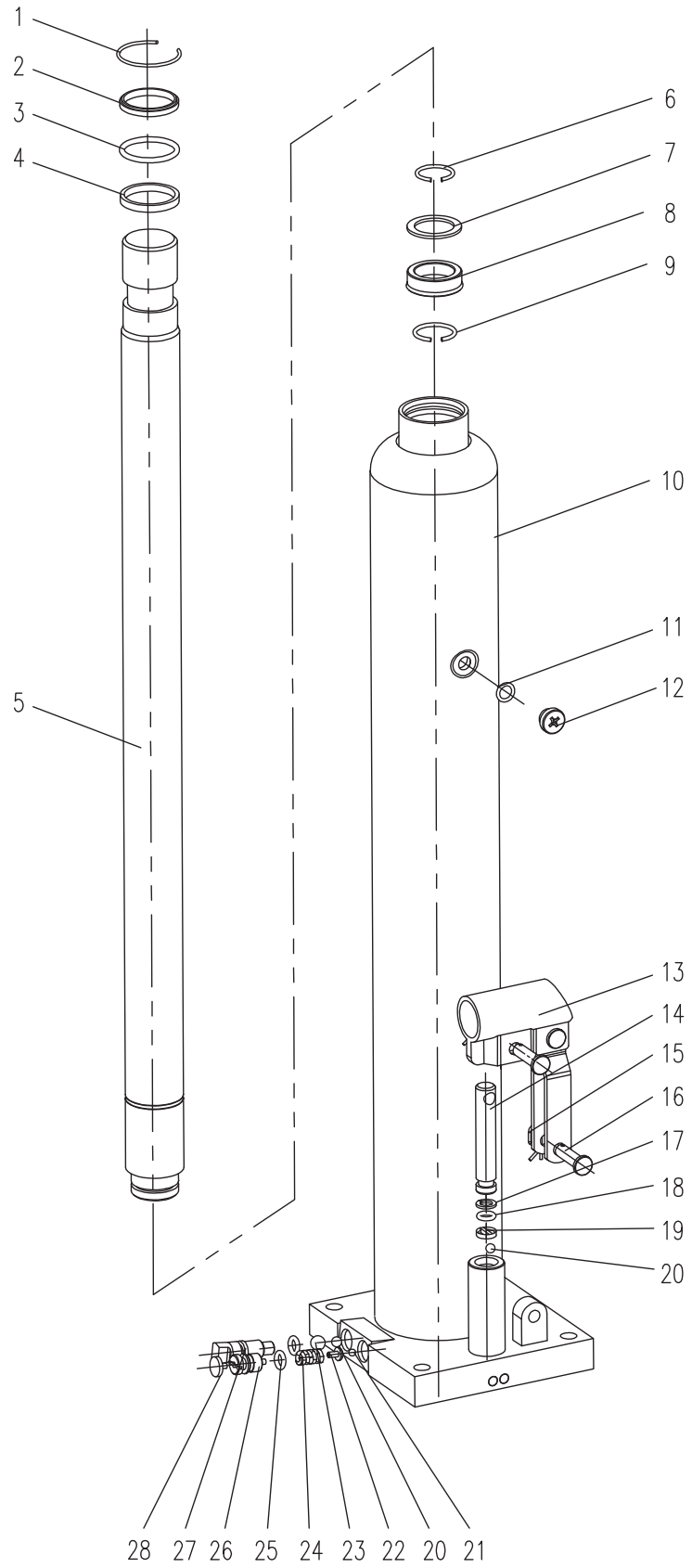

LONG RAM JACK ASSEMBLY PARTS LIST

Index #	Description	Part No.	Qty
1	Piston	TH90604-1	1
2	Upper rectangular ring	TH90604X-1	1
3	O-Ring 31.5x3.55-G-N	GB/T 3452.1	1
4	Rectangular ring	TH90604-2	1
5	Piston rod	TEL05001H.1-1	1
6	Roundwire snap ring	T30506-6	1
7	Wire ring	T30506-9	1
8	Y-Ring	T30506-10	1
9	Piston	T30506-11	1
10	Base welding parts	TEL05001H.1.1	1
11	O-Ring	QLQ2.1-17	1
12	Oil plug	T815016L.3-13	1
13	Handle socket	TH90404A.2	1
14	Pump plunger assembly	TH92004-4	1
15	Cutter pin	QLQD2B.2-5	2
16	Pin	T90403-19	2
17	Pump plunger retainer	T90403-27	1
18	O-Ring	T90403-28	1
19	Steel ball retainer	TH92004-5	1
20	Steel ball 5mm	GB/T 308	2
21	Steel ball 4mm	GB/T 308	1
22	Spring holder	TQ22001.1-24	1
23	Steel ball 6mm	GB/T 308	1
24	Spring	TP03001.1-26a	1
25	O-Ring	QLQ2.1-14	2
26	Adjusting screw	T91004-38	1
27	Release valve assembly	QYL8-25A	1
28	Plastic plug	QLQD2A-17a	1

Safe Operating Temperature is between 40°F – 105°F (4°C - 41°C)

REPLACEMENT PARTS

For replacement parts Customer Service at **1-800-222-5381**. Not all equipment components are available for replacement; illustrations provided are a convenient reference of location and position in the assembly sequence. When ordering parts the following will be required: Model Number, Serial Number and Description.

The distributor reserves the rights to make design changes and or improvements to product lines and manuals without notice.

For replacement parts and technical questions, please call 1-800-222-5381.

Limited Warranty

Limited Warranty

Northern Tool and Equipment Company, Inc. ("We" or "Us") warrants to the original purchaser only ("You" or "Your") that the Strongway product purchased will be free from material defects in both materials and workmanship, normal wear and tear excepted, for a period of one year from date of purchase. The foregoing warranty is valid only if the installation and use of the product is strictly in accordance with product instructions. There are no other warranties, express or implied, including the warranty of merchantability or fitness for a particular purpose. If the product does not comply with this limited warranty, Your sole and exclusive remedy is that We will, at our sole option and within a commercially reasonable time, either replace the product without charge to You or refund the purchase price (less shipping). This limited warranty is not transferable.

Limitations on the Warranty

This limited warranty does not cover: (a) normal wear and tear; (b) damage through abuse, neglect, misuse, or as a result of any accident or in any other manner; (c) damage from misapplication, overloading, or improper installation; (d) improper maintenance and repair; and (e) product alteration in any manner by anyone other than Us, with the sole exception of alterations made pursuant to product instructions and in a workmanlike manner.

Obligations of Purchaser

You must retain Your product purchase receipt to verify date of purchase and that You are the original purchaser. To make a warranty claim, contact Us at 1-800-222-5381, identify the product by make and model number, and follow the claim instructions that will be provided. The product and the purchase receipt must be provided to Us in order to process Your warranty claim. Any returned product that is replaced or refunded by Us becomes our property. You will be responsible for return shipping costs or costs related to Your return visit to a retail store.

Remedy Limits

Product replacement or a refund of the purchase price is Your sole remedy under this limited warranty or any other warranty related to the product. We shall not be liable for: service or labor charges or damage to Your trailer incurred in removing or replacing the product; any damages, including, without limitation, damages to tangible personal property or personal injury, related to Your improper use, installation, or maintenance of the product; or any indirect, incidental or consequential damages of any kind for any reason.

Assumption of Risk

You acknowledge and agree that any use of the product for any purpose other than the specified use(s) stated in the product instructions is at Your own risk.

Governing Law

This limited warranty gives You specific legal rights, and You also may have other rights, which vary from state to state. Some states do not allow limitations or exclusions on implied warranties or incidental or consequential damages, so the above limitations may not apply to You. This limited warranty is governed by the laws of the State of Minnesota, without regard to rules pertaining to conflicts of law. The state courts located in Dakota County, Minnesota shall have exclusive jurisdiction for any disputes relating to this warranty.



Distributed by

Northern Tool + Equipment Co., Inc.

Burnsville, Minnesota 55306

NorthernTool.com

Made in China