



M1118G.1

ITEM NUMBER: 1118

SERIAL NUMBER: _____

Owner's Manual

Instructions for Assembly, Testing, Operation, Servicing and Storage

37-Ton Log Splitter: Outdoor hydraulic powered machine that splits wood logs.

WARNING

READ and UNDERSTAND this manual completely before using log splitter.

All operators of this equipment must read and completely understand all safety information, operating instructions, maintenance and storage instructions. Failure to properly operate and maintain the log splitter could result in serious injury to the operator and bystanders from moving parts that can crush or cut, flying objects, burns, fire or explosion, escaping high pressure hydraulic fluid, or carbon monoxide poisoning in particular, be aware of the following hazards.

Crush and Cut Hazards

Moving parts can crush and cut hands and fingers. Keep hands clear of endplate, wedge, logs, and log strippers while splitting.

High Pressure Hydraulic Fluid Hazards

High fluid pressures and temperatures are developed in hydraulic log splitters. Hydraulic fluid escaping through even a pin-size hole opening can puncture skin and cause severe blood poisoning. Inspect hydraulic system regularly for possible leaks. Never check for leaks with your hand while the system is pressurized. Seek medical attention immediately if injured by escaping fluid.

Fire Hazards

- If your log splitter is intended for use near an ignitable forest, brush, or grassy covered land, the engine exhaust should be equipped with a spark arrestor. See the "Specifications" section of this manual to determine if your splitter already has a spark arrestor. If not equipped, call NorthStar Product Support for ordering information.
- Keep a fire extinguisher rated "ABC" nearby. Keep it properly charged and be familiar with its use

STOP!

ADD OIL TO ENGINE BEFORE USING: Engine is shipped without oil. DO NOT start log splitter without first adding oil.

ADD HYDRAULIC OIL: Your log splitter was shipped without hydraulic oil. Refer to Periodic Maintenance section of this manual for instructions on filling the hydraulic reservoir

PRIME THE PUMP: The pump on your log splitter needs to be primed before use. Refer to Initial Setup section for instructions.

INSPECT COMPONENTS: Closely inspect to make sure no components are missing or damaged.

See Initial Unpacking and Set-up for instructions and for whom to contact to report missing or damaged parts.

Any Questions, Comments, Problems or Parts Orders

Call NorthStar Product Support 1-800-270-0810

Hazard Signal Word Definitions





	<p>This is the safety alert symbol. It is used to alert you to potential personal injury hazards. Obey all safety messages that follow this symbol to avoid possible injury or death.</p>
	<p>DANGER (red) indicates an imminently hazardous situation which, if not avoided, will result in death or serious injury.</p>
	<p>WARNING (orange) indicates a potentially hazardous situation which, if not avoided, could result in death or serious injury.</p>
	<p>CAUTION (yellow) indicates a potentially hazardous situation which, if not avoided, may result in minor or moderate injury.</p>
	<p>CAUTION (yellow) used without the safety alert symbol indicates a potentially hazardous situation which, if not avoided, may result in property damage.</p>

fig01453

Table of Contents

Hazard Signal Word Definitions	2
Table of Contents	3
About Your Log Splitter	4
Safety Label Locations.....	5
Machine Component Identification.....	8
Initial Setup	9
Moving and Towing to the Job Site.....	11
Before Each Use — Inspection/Maintenance.....	14
Before Each Use - Fueling	17
Before Each Use – Work Site Selection and Set-up	18
Splitting Operation.....	19
Storage	25
Periodic Maintenance	26
Troubleshooting.....	27
Specifications	28
Parts Breakdown – Exploded View 1118 – Rev G.1	29
Summary of Important Safety information for Operation	31
Assembly Instructions	36
Limited Warranty	65
California proposition 65 information	66

About Your Log Splitter

Thank you for purchasing your NorthStar log splitter!

About Your Log Splitter:

This log splitter is a machine designed to split wood logs using a hydraulically powered moving wedge. The log splitter's gasoline engine is used to pressurize the hydraulic system.

This log splitter is designed to split logs *lengthwise with the grain only*.

This log splitter model is capable of splitting logs up to 25' long and 16" in diameter.

Your splitter can be used in either a vertical or horizontal splitting position:

- When the splitter is set up to operate in the horizontal splitting position, a log is placed on the horizontal beam and the wedge moves horizontally into the end of the log to split it.
- When the splitter is set up to operate in the vertical splitting position, the log is placed on the endplate, upright on its end, and the wedge moves down into the top of the log to split it.

The horizontal splitting position is used for lighter logs that can be easily loaded onto the beam. The vertical splitting position is used for heavier logs that are difficult to load onto the beam.

The technical specifications for your log splitter are provided in the Specifications section of this manual.

WARNING

This log splitter uses a high-pressure hydraulic system to generate a very strong splitting force.

Read the manual completely before using the machine to understand how to safely operate and maintain it.

Follow all safety precautions presented throughout this manual. A summary of important safety information can be found at the end of this manual.

Contact NorthStar Product Support at 1-800-270-0810 for any questions about the appropriate use of this log splitter and/or optional accessories.

Warranty Registration:

Please fill out and submit the warranty registration card so that we have your contact information for any future product literature or replacement parts you may need.

Attention: All Rental Companies and Private Owners who loan this equipment to others!

All persons to whom you rent/loan the log splitter must have access to and read this manual. Keep this owner's manual with the splitter at all times and advise all persons who will operate the machine to read it. You must provide instruction on how to safely operate the splitter and remain available to answer any questions a renter/borrower might have.

Safety Label Locations

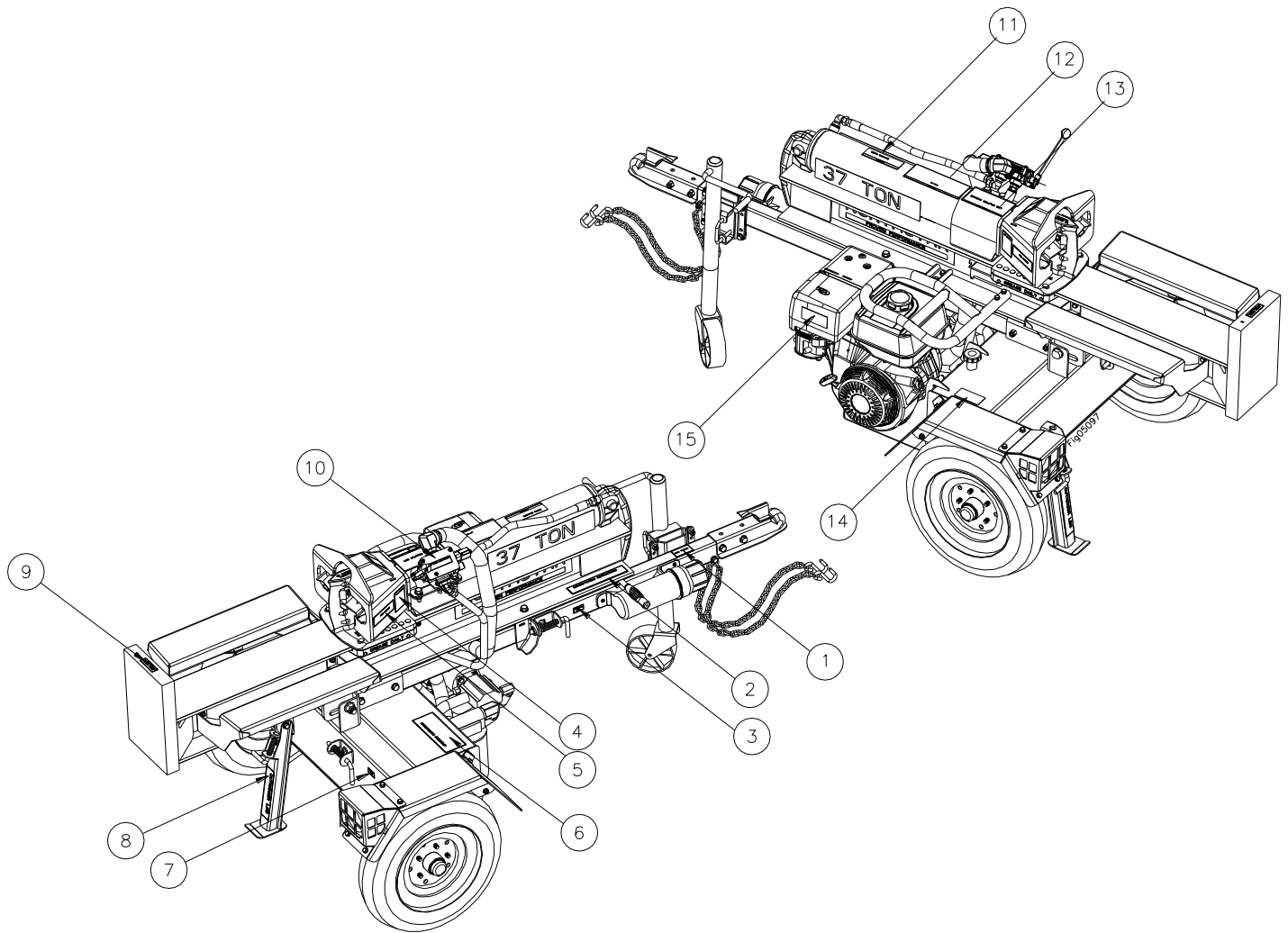

Reference #	Part Number	Description	Qty
1	791123	Decal, 45 mph	1
2	791105	Decal, Moving/Towing Instructions	1
3	778597	Decal, Horizontal Lock	1
4	778717	Decal, Log Stripper	3
5	777890	Decal, Fire Hazard Warning	2
6	777887	Decal, Operation Instructions	1
7	778714	Decal, Vertical Lock	1
8	791107	Decal, Outrigger Leg	1
9	787944	Decal, Pinch Point	1
10	778609	Decal, Split Control	1
11	777891	Decal, Escaping Fluid	1
12	777889	Decal, Stuck Log	1
13	778610	Decal, Log Splitter Warning	1
14	788935	Decal, Fuel Fire Explosion Hazard	1
15	788937	Decal, Poisonous Gas Warning	1

Always make sure safety labels are in good condition. If a safety label is missing or not legible, order new labels or unsafe operation could result. **Contact NorthStar Product Support at 1-800-270-0810**

Safety Label Locations

1

MAX TOWING SPEED
45
MPH

2

MOVING/TOWING INSTRUCTIONS

Moving log splitter by hand:

- Lock beam in horizontal position (tip-up models only).
- Lock towbar leg or jack stand in DOWN position.
- Lock support leg in UP position (if equipped)
- Do not attempt to move log splitter up or down slope by hand.

Towing log splitter:

- Latch coupler securely to class 2 or higher hitch with 2" ball.
- Lock towbar leg/jack stand or support leg (if equipped) in the UP position.
- Attach safety chains to tow vehicle.
- Close fuel shut-off valve on engine (if equipped)
- Do not tow faster than 45 mph. Higher speeds can cause loss of control.
- Check local, state, and federal requirements before towing on public roads.

PN 791105

3

HORIZONTAL LOCK

PN 778597

5

WARNING
FIRE HAZARD



Hot exhaust can ignite dry brush, trees, or grass.

- Equip engine with a spark arrester if you will be using near ignitable forest, brush or grassy covered land.
- Keep a fire extinguisher on hand that is rated for ordinary combustibles & flammable liquids.

PN 777800

4

**LOG STRIPPER
RETRACT WEDGE
TO REMOVE
STUCK WOOD**

WARNING



PINCH POINT

Keep hands clear of wedge and log stripper

778711

6

OPERATING INSTRUCTIONS

GENERAL

- Stay in the OPERATOR POSITION while actuating controls.
- Never actuate controls until the helper is 10ft away from log splitter, including any helpers assisting to load logs.
- Wear eye protection, hearing protection, snug fitting gloves, and safety shoes or heavy boots. No loose or dangling apparel.

SETTING UP

- Place log splitter on dry, level ground.
- Secure splitter for unintended movement.
- Place splitter in horizontal or vertical position.
- Start engine/motor.

SPLITTING LOG

- Position log on beam, against endplate.
- Move split control to extend wedge and split log.
- Release split control to stop wedge.
- Move split control to return wedge.
- Remove split wood from work area.

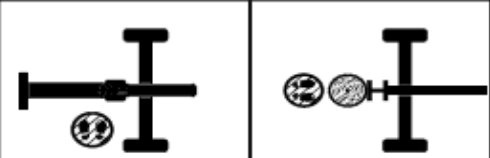

Operator Position - horizontal | Operator Position - vertical

PN 777800

7

VERTICAL LOCK

PN 778714

8

**OUTRIGGER LEG
LOCK OUTRIGGER LEG IN THE
DOWN POSITION BEFORE SPLITTING**

PN 778714

9

WARNING



PINCH POINT
Keep hands clear during operation.



787944

10

SPLIT CONTROL LEVER OPERATION



11

WARNING



ESCAPING HIGH PRESSURE HYDRAULIC FLUID HAZARD

High fluid pressures and temperatures are developed in the hydraulic system. Hydraulic fluid escaping through even a pin-size hole opening can puncture skin and cause blood poisoning.

- Inspect hydraulic system regularly for leaks
- Never check for leaks with your hand while system is pressurized.
- Seek medical attention immediately if injured by escaping fluid.

PN 777800

12

WARNING

IF LOG BECOMES STUCK ON WEDGE

A log can become stuck to the wedge if the wedge becomes embedded in the log and the log doesn't split and separate. This can happen if the log is too stringy or tough to split completely. A stuck log will move back with the wedge on the initial attempt to retract the wedge. **If this happens, STOP retracting the wedge immediately** and follow the directions below.

NEVER attempt to remove a stuck log by:

- Using the hydraulic force of the splitter
- Modifying the splitter
- Adding attachments to the splitter.

Personal injury could result from log or metal pieces flying out at high speed toward the operator or bystanders, or the splitter could become damaged.

ALWAYS remove the log MANUALLY using the following procedure:

1. If there is already 1" or more of clearance between the log and endplate, go to step 2. Otherwise, retract wedge just enough to remove pressure between the log and endplate - about 1" clearance.
2. Turn engine/motor OFF.
3. Remove stuck log from the wedge manually with a pry bar or sledgehammer.



Important: Be extremely careful as log pieces may fly off as they separate from the wedge. Wear safety goggles and make sure bystanders are clear.

4. Do not attempt to resplit a stuck log once it has been removed from the wedge.

PN 777889

Safety Label Locations

13

⚠ WARNING	
 	<p>Moving parts can crush and cut. Pieces can fly out while splitting. Follow safety rules for operating the log splitter or serious injury could result.</p> <ul style="list-style-type: none"> •READ the Owner's Manual completely before operating. •Only one person should operate the log splitter. If an assistant is helping to load logs, the operator should not actuate controls until the assistant is at least 10 ft away. •Stay in the designated OPERATOR POSITION while actuating the controls. •Split wood in direction of the grain only. •Hold bark side of logs when loading. •Keep hands away from wedge, endplate/ram, and partly split logs. •Never leave log splitter unattended during operation. •Stay off slopes and slippery surfaces. <p>See additional safety rules in the Owner's Manual.</p>

14

⚠ WARNING	
  	<p>Fuel Fire/Explosion Hazard Fuel is flammable and explosive.</p> <p>Never fuel a running or hot engine. Clean up fuel spills immediately. Ensure there are no fuel leaks before starting. Keep sources of sparks and flames away. Hot exhaust may also ignite spilled fuel. No Smoking. Keep a fire extinguisher nearby.</p>

15

⚠ WARNING	
	<p>Poisonous Gas</p> <p>This product gives off carbon monoxide, a poisonous gas that can kill you. You CANNOT smell it, see it, or taste it.</p> <ul style="list-style-type: none"> - ONLY use outside & far away from windows, doors, & vents. - NEVER use inside homes, garages, or sheds, EVEN if you run a fan or open doors or windows. <p>See owner's manual for more details.</p>

Machine Component Identification

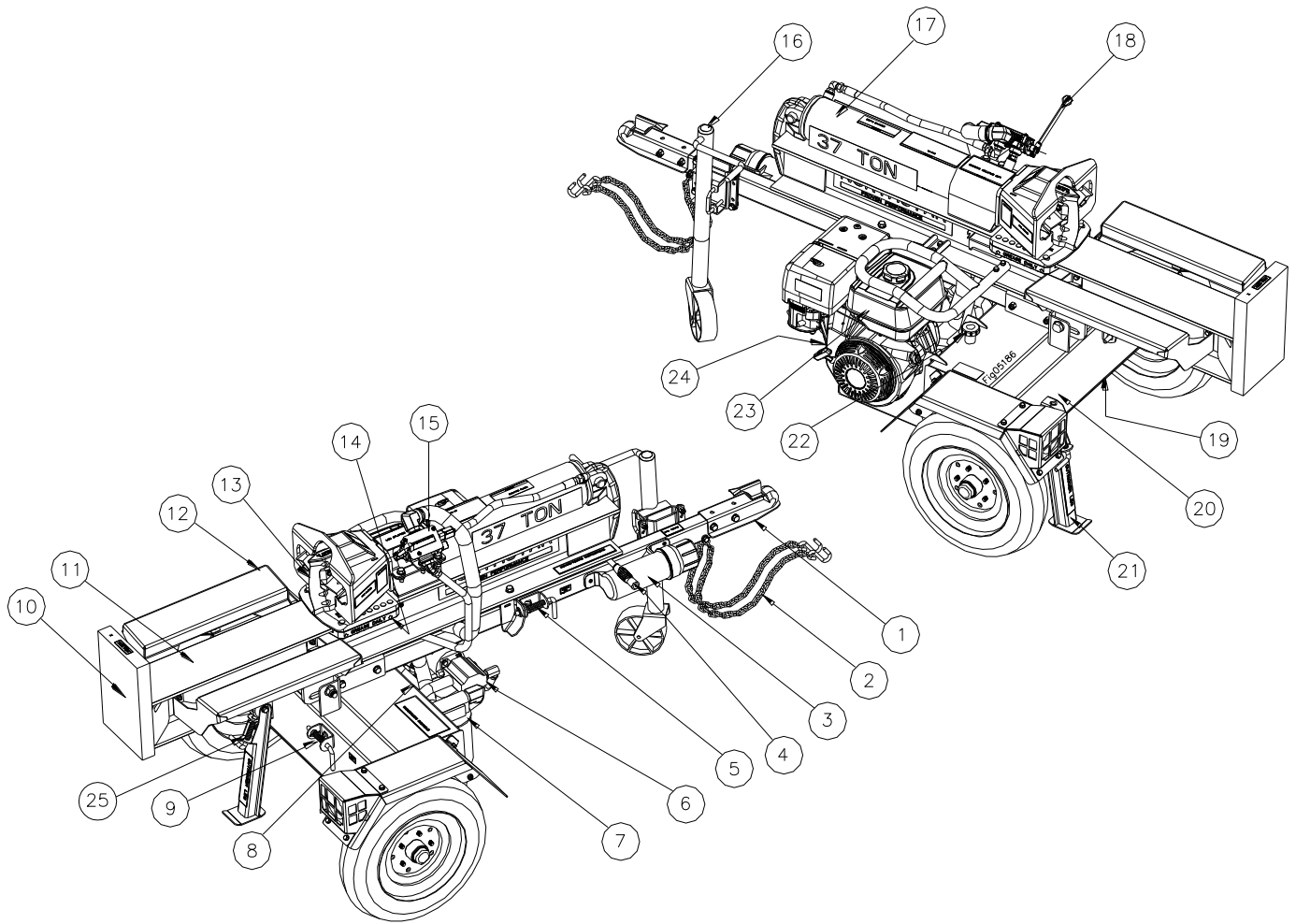

Ref #	Description
1	2" Ball Coupler
2	Safety Chains
3	Manual Tube
4	Lifting Handle
5	Horizontal Lock
6	Hydraulic Pump
7	Return Line Filter
8	Suction Strainer
9	Vertical Lock
10	Endplate
11	Beam
12	Log Cradles
13	Wedge

Ref #	Description
14	Grease Zerks
15	Split Control Lever
16	Jack
17	Cylinder
18	Control Valve
19	Magnetic Drain Plug
20	Hydraulic Tank
21	Outrigger Leg
22	Breather Cap/Oil Dipstick
23	Engine
24	Serial Number
25	Outrigger Leg Lock

Initial Setup

IMPORTANT!

Engine is shipped without oil. DO NOT start the engine before adding oil.

See Assembly Instructions section of this manual to assemble the log splitter before setup.

Step One: **Inspect Log Splitter Components.**

Closely inspect all log splitter components.

(See Machine Components section of this manual for diagram of components.)

- If you have missing or damaged components, please contact Product Support at 1-800-270-0810.

Step Two: **Add Oil to Engine**

Add oil to the engine. Using a funnel, add SAE 10W-30 oil up to the FULL mark on the dipstick. (See engine Owner's Manual for oil capacity and location of fill cap.)

Step Three: **Add Hydraulic Oil to Reservoir and Prime the Pump**

⚠ WARNING: High fluid pressures and temperatures are developed in hydraulic log splitters. Hydraulic fluid escaping through a pin hole sized opening can burn or puncture skin, resulting in wounds that could cause blood poisoning, infection, disability, gangrene, amputation, or death. Therefore, the following instructions should be heeded at all times when inspecting or servicing the hydraulic components of the log splitter.

- NEVER check for leaks with your hand. Leaks can be located by holding a piece of cardboard or wood (at least two feet long) with your hand at one end and passing the other end over the suspected area (wear eye protection). Look for discoloration of the cardboard or wood.
- NEVER adjust the pressure of the pump or valve.
- If injured by escaping fluid, no matter how small the wound is, see a doctor at once. A typical injection injury may be a small wound that does not look serious. However, severe infection or reaction can result if proper medical treatment is not administered immediately by a doctor who is familiar with injection injuries.

1. Remove hydraulic oil dipstick.
2. Refer to the **Specifications** section for approximate hydraulic oil capacity.
3. Fill reservoir with 10 wt. AW32, ASLE H-150, or ISO 32 oil. Use a funnel
4. Replace hydraulic oil dipstick and check that oil level reads full. Note: Do not thread in dipstick when checking oil level.

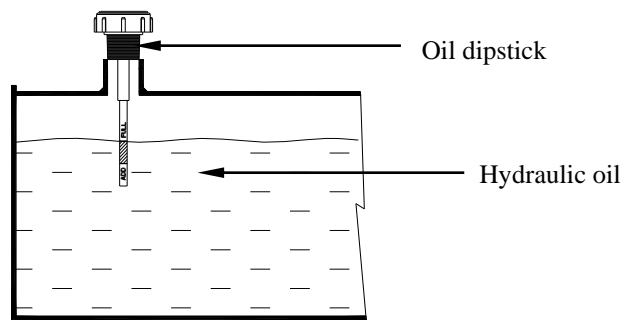

5. Disconnect the spark plug wire from the spark plug
6. Pull on the starter grip recoil at least 20 times so that hydraulic fluid has cycled through the pump
7. Reconnect the spark plug wire to the spark plug
8. Start engine and use control valve handle to extend and retract wedge 5 (five) times to remove air from the high pressure lines.
9. With wedge retracted, check oil level again.

Initial Setup

10. Replace hydraulic oil fill/vent cap.
11. Start engine and use control valve handle to extend and retract wedge five (5) times to remove air from the high-pressure lines.
12. With wedge retracted, check oil level again. Fill if necessary.

⚠ WARNING: NEVER remove the hydraulic oil fill cap when the engine is running or hot. Hot oil can escape causing severe burns. Allow log splitter to cool completely before removing hydraulic oil fill cap.

Note: If the log splitter will be run for long periods of time in outdoor temperatures above 70°F, we recommend changing the hydraulic oil to DEXRON III.

Step Four: **Lubricate Keepers**

Pump grease into grease zerks found under each keeper. This will help prevent wear between the keepers and beam.

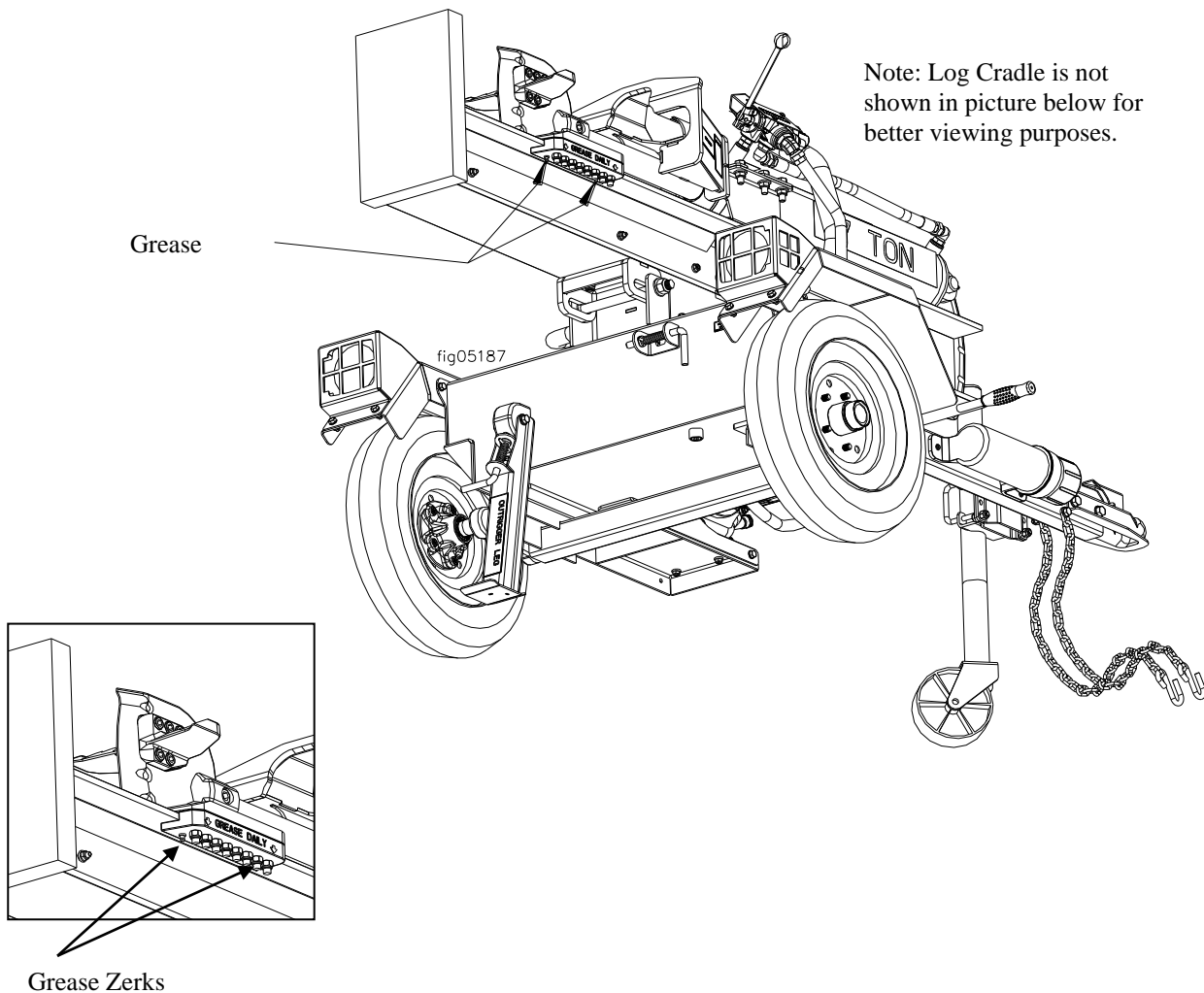

Moving and Towing to the Job Site

⚠️ WARNING

The log splitter is heavy. It can crush and cause serious injury if it rolls out of control or tips over.

Follow the instructions below for safely moving and towing the log splitter.

Moving the log splitter:

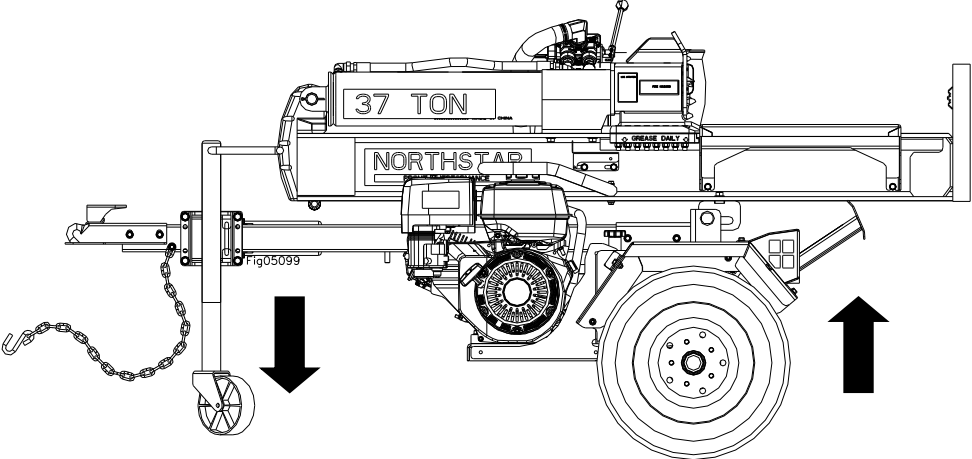
<p>1. Place in Horizontal position</p>	<p>Make sure the log splitter is locked in the horizontal position with hitch pin before moving.</p> <p>NEVER move log splitter when it is in vertical configuration because it will be unstable and could tip.</p>
<p>2. Engine off.</p>	<p>IMPORTANT: Make sure log splitter engine is off.</p> <p>Never move the log splitter with its engine running.</p>
<p>3. Fuel valve off (if equipped)</p>	<p>Turn fuel valve off to prevent carburetor flooding and reduce the chance of fuel leakage. Refer to Engine owner's manual for fuel valve location.</p>
<p>4. Lock:</p> <ul style="list-style-type: none"> • Front <u>jack</u> DOWN • Rear <u>outrigger leg</u> UP 	<p>Lock jack in DOWN position and the rear outrigger leg in the UP position before you move the log splitter.</p>  <p style="text-align: center;">Jack DOWN Position</p> <p style="text-align: right;">Outrigger UP Position</p>
<p>5. Move log splitter to work site or tow hitch</p>	<p>Move log splitter by hand either directly to chosen work site or to vehicle hitch for towing.</p> <p>(See Before Each Use: Step Three: instructions on selecting a work site)</p> <p><u>Important Safety Instructions:</u></p> <ul style="list-style-type: none"> • Hills. Do not move the log splitter up or down hills by hand—use a towing vehicle. • No riding. Never allow anyone to sit or ride on the log splitter. • No cargo. Never transport cargo or wood on the log splitter.

Moving and Towing to the Job Site

Towing:

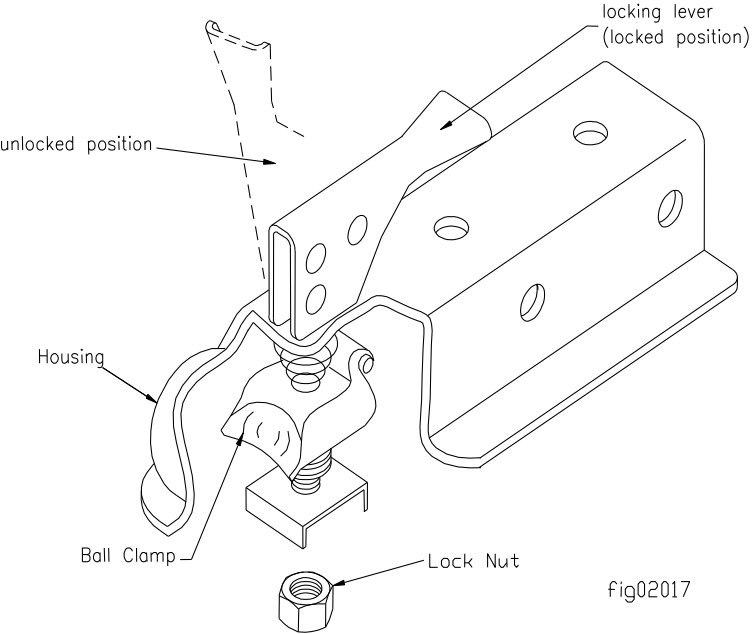
1. Read instructions	Review towing safety instructions in your vehicle manual.
2. Check tires	Make sure tires are fully inflated and in good repair. ⚠️ WARNING: <ul style="list-style-type: none">• Do not over-inflate tires. Serious injury can occur if tire explodes.• When seating a bead after repair, do not exceed 30 PSI. Pressures higher than 30 PSI can cause the tire and wheel to rupture and explode.
3. Attach to hitch (2" ball)	Attach log splitter to vehicle hitch <ol style="list-style-type: none">1. Attach log splitter's coupler to a class 2 or higher hitch with 2" ball (only).2. Adjust coupler to ball by raising locking lever and turning lock nut with fingers.3. Proper adjustment is obtained when coupler is as tight as possible on ball and locking lever can still be opened and closed.4. Lock lever closed to secure the attachment. An optional locking pin or padlock may be inserted in the locking lever hole for extra security.  <p>fig02017</p>
4. Attach safety chains	Attach safety chains. <ol style="list-style-type: none">1. Two safety chains must be used while towing.2. Cross safety chains under the coupler allowing only enough slack for vehicle turns.

Moving and Towing to the Job Site

5. Lock jack and outrigger leg UP

Move the **front outrigger leg to the UP position and lock**. (Both outrigger legs must remain in the up position during towing.)

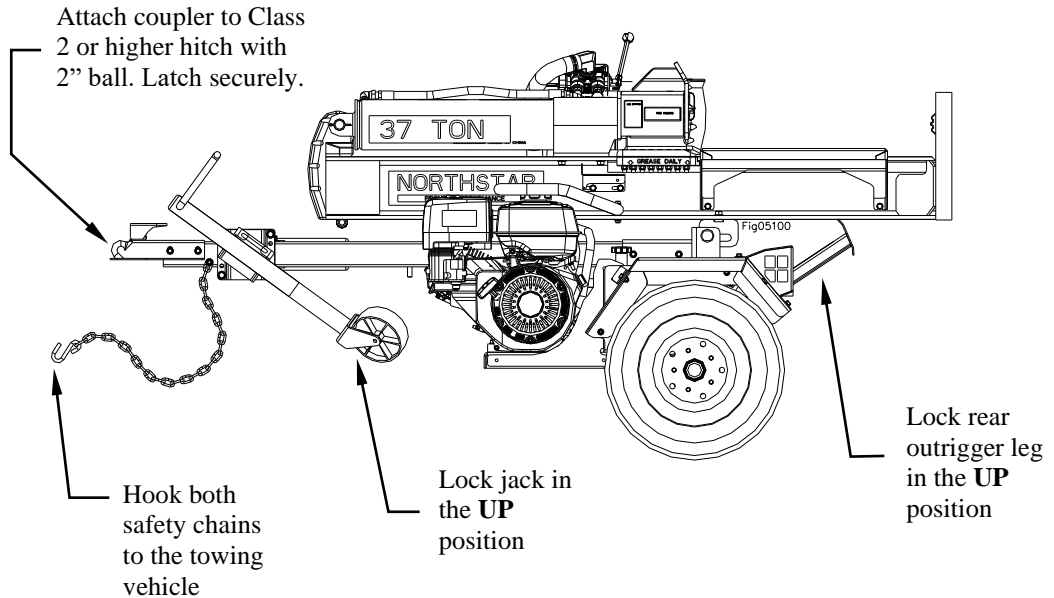

6. Tow to desired location

Tow log splitter carefully to desired work site.
(See Before Each Use section on selecting an appropriate work site)

Important safety instructions:

- **Added length.** Be aware of the added length of the splitter.
- **Speed limit.** Never tow this log splitter over 45 mph. Faster speeds may result in loss of control.
- **Rough terrain.** Drive slowly and take extra caution when traveling over rough terrain.
- **On public roads.** If towing on a public road, make sure to comply with all local, state, and federal towing requirements. It is the sole responsibility of the purchaser to obtain licensing, trailer lights, safety chains or signage, as needed to comply.
- **Unattended.** Turn off the towing vehicle before leaving the splitter unattended.
- **Under the influence.** Never tow or operate this splitter while under the influence of alcohol, drugs, or medication.

7. Lock front outrigger leg down and unhitch

Lock front outrigger leg in the DOWN position and disconnect from vehicle.
NEVER operate log splitter while it is attached to the vehicle.

Before Each Use — Inspection/Maintenance

Step One: Inspect and maintain log splitter before each use

If the log splitter has been used previously, it must be inspected and maintained BEFORE EACH SUBSEQUENT USE.

⚠ WARNING

ALWAYS shut off the engine, disconnect the spark plug, and relieve system pressure before inspecting, cleaning, adjusting, or repairing the splitter. Relieve system pressure by moving Split Control Lever back and forth several times.

IMPORTANT:

If a part needs replacement, only use parts that meet the manufacturer's specifications. Replacement parts that do not meet specifications may result in a safety hazard or poor operation of the log splitter.

1. Engine off / relieve pressure	<p>Perform all inspections/repairs with the engine off and hydraulic system pressure relieved.</p> <ol style="list-style-type: none"> 1. Make sure engine is off and cool. 2. Disconnect the spark plug 3. Relieve all hydraulic system pressure by moving the Split Control Lever back and forth several times.
2. Remove debris	<p>Remove debris from engine, muffler, and moving parts.</p> <ol style="list-style-type: none"> 1. <u>Engine debris.</u> Debris on a hot engine can be a fire hazard. Clean debris and chaff from engine cylinder head, cylinder head fins, blower housing rotating screen, and muffler areas. Avoid contact with hot muffler. 2. <u>Other debris.</u> Debris on moving parts can cause excess wear. Clear debris from the slide beam, wedge, and endplate.
3. Fuel tank / lines	<p>Check fuel tank and fuel lines for leaks.</p> <p>Any fuel leak is a fire hazard. Fix any fuel leaks before starting engine.</p>

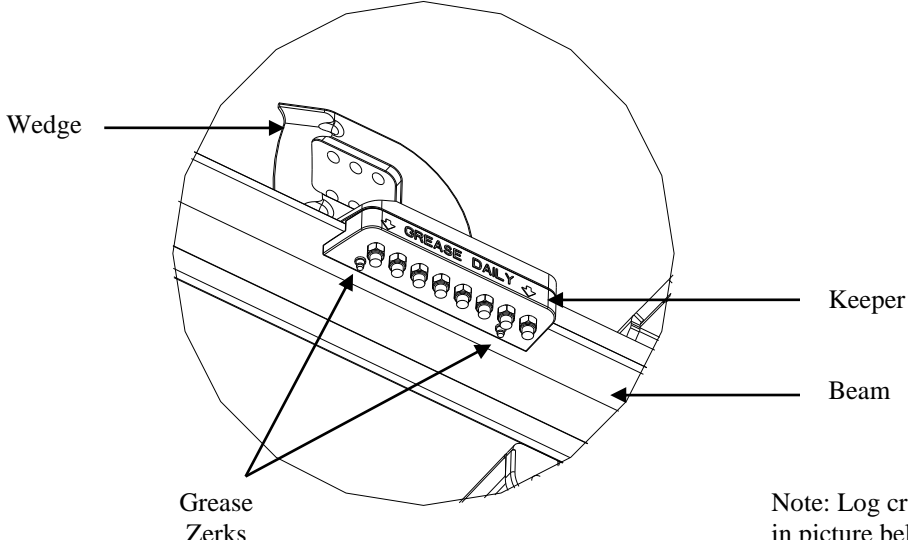
4. Mechanical parts	<p>Check to be sure that all nuts and bolts are tight to make sure the log splitter is in safe working condition.</p> <p>Apply grease to grease zerks under both keepers.</p> <div style="text-align: center; margin-top: 20px;">  </div> <p style="text-align: right; margin-top: 20px;">Note: Log cradle is not shown in picture below for better viewing purposes</p>
----------------------------	--

Before Each Use — Inspection/Maintenance

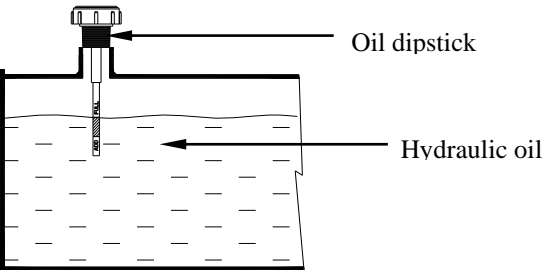
5. Hydraulic system	<p>Check the hydraulic system carefully:</p> <ol style="list-style-type: none"> 1. Visually inspect all hoses, tubing, clamps/fittings, pump, and cylinder for cracks, fraying, kinks, or other damage. 2. Check all components for oily residue, which may indicate a leak. <p>Do NOT operate the log splitter if there is any indication of damage or oily residue. Small leaks in hydraulic lines can cause severe injuries and can also be an indication of catastrophic failure in the near future. The life of hydraulic hoses may be from a few months to a few years, depending on use and storage patterns.</p> <p>⚠ WARNING: High fluid pressures and temperatures are developed in hydraulic log splitters. Hydraulic fluid escaping through a pin hole sized opening can burn or puncture skin, resulting in wounds that could cause blood poisoning, infection, disability, gangrene, amputation, or death. Therefore, the following instructions should be heeded at all times when inspecting or servicing the hydraulic components of the log splitter:</p> <ul style="list-style-type: none"> • Stop the engine, disconnect the spark plug, and move all control valve handles back and forth to relieve pressure before changing or adjusting hydraulic system components such as hoses, tubing, fittings or other components. • NEVER check for leaks with your hand. Leaks can be located by holding a piece of cardboard or wood (at least two feet long) with your hand at one end and passing the other end over the suspected area (wear eye protection). Look for discoloration of the cardboard or wood. • NEVER adjust the pressure setting of the pump or valve. • If injured by escaping fluid, no matter how small the wound is, see a doctor at once. A typical injection injury may be a small puncture wound that does not look serious. However, severe infection or reaction can result if proper medical treatment is not administered immediately by a doctor who is familiar with injection injuries.
6. Hydraulic oil level	<p>Check the hydraulic oil level. Fill as needed – check that oil level reads full. Note: Do not thread in dipstick when checking oil level.</p> <div style="text-align: center; margin: 10px 0;">  </div> <p>⚠ WARNING: NEVER remove the hydraulic oil dipstick when the engine is running or hot. Hot oil can escape causing severe burns. Allow log splitter to cool completely before removing hydraulic oil dipstick.</p>
7. Engine	Inspect and perform engine maintenance as directed in the engine manual.
8. Spark arrestor muffler	<p>If the engine is equipped with a spark arrestor muffler, clean and inspect it regularly (follow spark arrestor manufacturer's service instructions).</p> <p>Replace if damaged.</p>

Before Each Use — Inspection/Maintenance

9. Tires

Make sure tires are fully inflated and in good repair if you will be towing the splitter.

See tire sidewall for recommended tire pressure.

 WARNING:

- Do not over-inflate tires. Serious injury can occur if tire explodes.
- When seating a bead after repair, do not exceed 30 PSI. Pressures higher than 30 PSI can cause the tire and wheel to rupture and explode.

10. Shields / guards

Replace all guards and shields after servicing the log splitter.

Before Each Use - Fueling

Step Two: Fueling

⚠ WARNING

Gasoline is highly flammable and explosive. You can be burned or seriously injured when handling fuel. Use extreme care when handling gasoline.

1. Engine off / cool	<p>The engine must be off and allowed to cool at least two minutes before adding fuel.</p> <p>⚠ WARNING: A running engine is hot enough to ignite fuel. Never add fuel or remove gas cap if engine is running or still hot.</p>
2. Outdoor location	<p>Fill fuel tank outdoors – never indoors.</p> <p>⚠ WARNING: Gasoline vapors can ignite if they collect inside an enclosure. Explosion can result.</p>
3. Remove gas cap	<p>Remove engine gas cap.</p>
4. Add gasoline	<p>Add gasoline through fill opening from a UL listed container.</p> <p><u>Important Safety Instructions:</u></p> <ul style="list-style-type: none"> • Use approved container. NEVER pump fuel directly into engine at gas station. Static charge can build and ignite fuel. Use a UL listed fuel container to transfer gas to the engine. • Don't overfill. DO NOT overfill the gas tank. Allow at least 1/2" of empty space below the fill neck to allow for fuel expansion • Heat / flames / sparks. Stay away from sources of heat, flame, or sparks while adding fuel. <div style="float: right; border: 2px solid black; padding: 5px; margin-top: 10px;"> <p style="text-align: center; font-weight: bold; font-size: 1.2em;">WARNING</p> <p style="font-size: 0.8em;">FEDERAL LAW prohibits the use of E15 in small engines. Per the EPA, E15 should ONLY be used in 2001 and newer passenger vehicles.</p> <div style="text-align: center;">  </div> <p style="text-align: right; font-size: 0.6em;">790134</p> </div>
5. Spills / splashes	<p>Clean up fuel spills /splashes immediately.</p> <ol style="list-style-type: none"> 1. Move the log splitter away from spilled fuel on the ground. 2. Wipe fuel off engine and wait 5 minutes for excess fuel to evaporate before starting engine. 3. Gas soaked rags are flammable and should be disposed of properly. 4. If gasoline is spilled on your skin or clothes, change clothes and wash skin immediately.
6. Replace gas cap	<p>Replace gas cap securely before starting engine.</p>
7. Gasoline storage	<p>Store extra gasoline in a cool, dry place in a UL listed, tightly sealed container.</p>

Before Each Use – Work Site Selection and Set-up

Step Three: Work site selection and log splitter setup

⚠️ WARNING

It is important to select an appropriate work site and properly set up the log splitter in order to minimize the risk of slips and falls, equipment rolling or tipping over, carbon monoxide poisoning, and accidental fires.

1. Select location

Select an appropriate location for operating the log splitter.

Requirements:

1. Dry-level surface with good footing. Stay clear of areas with mud, ice, tall grass, weeds, brush, or snow.
2. Outdoors, away from air intakes.

⚠️ WARNING: The running engine gives off carbon monoxide, a poisonous gas that can kill you. You CANNOT smell it, see it, or taste it.

- ONLY run log splitter OUTDOORS and away from air intakes. NEVER run log splitter inside homes, garages, sheds, or other buildings or semi-enclosed spaces. These spaces can trap poisonous gases, EVEN if you run a fan or open windows.
- If you start to feel sick, dizzy, or weak while using the log splitter, shut off the engine and get to fresh air RIGHT AWAY. See a doctor. You may have carbon monoxide poisoning.

2. Fire precautions

Take the following precautions against fire:

1. **IMPORTANT:** If your splitter will be used near any unimproved forest, brush, or grassy covered land, then engine must be equipped with a spark arrestor.

(See the "Specifications" section of this manual to determine if your splitter already has a spark arrestor. Contact NorthStar Product Support at 1-800-270-0810 for information about obtaining a spark arrestor for your log splitter if it is unequipped.)

2. Make sure you comply with applicable local, state and federal codes.
3. Keeps a fire extinguisher rated "ABC" nearby as a precautionary measure when operating the log splitter in dry areas. Keep it properly charged and be familiar with its use.

3. Position splitter 7 feet from any combustibles or flammable liquids

Position muffler at least 7 ft. from combustible objects during operation.

Hot exhaust fumes from engine could cause fire. Also, hydraulic oil leaking or spraying on hot engine can ignite.

4. Lock jack and outrigger leg DOWN

Lock both the jack and outrigger leg in the DOWN position.

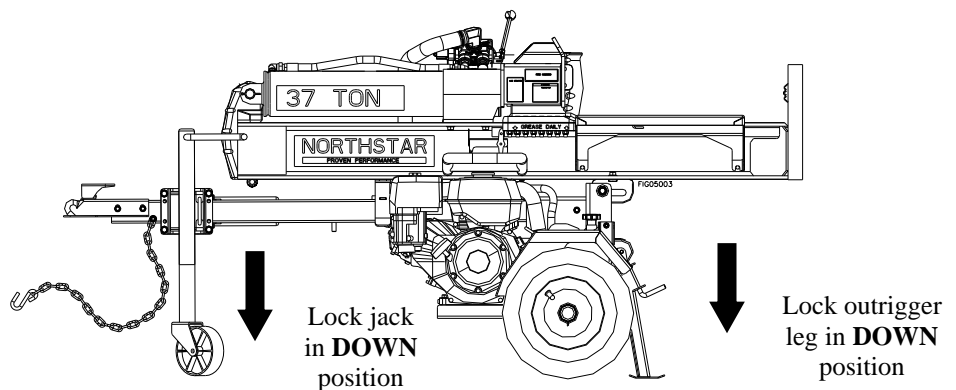

5. Block wheels

Block the wheels to prevent unintended movement of the log splitter.

6. Apply grease

Apply grease into grease zerks located under both keepers.

Splitting Operation

WARNING

Before starting this log splitter, review the following instructions and safety information for safe operation of the log splitter.

Failure to follow these rules may result in serious injury to the operator or bystanders from moving parts that crush, cut, or entangle from flying objects, burns, fire, falling or tripping, or from carbon monoxide poisoning.

General safety information:

- **Read manual.** Do not allow anyone to operate the log splitter who has not read the Owner's Manual or has not been instructed on the safe use of the splitter. The log splitter owner should instruct all operators in safe log splitter operation.
- **Age restrictions.** Never allow anyone under 16 years old to operate the log splitter. Anyone 16 years and older must be trained and supervised by a trained adult.
- **Intended use.** Log splitters should only be used for splitting wood logs, lengthwise with the grain. Do not use for other purposes as unforeseen hazards may result.
- **Modifications.** Never modify or alter the log splitter in any way. Modifications can create serious safety hazards and will void the warranty:
- **Attachments.** Never add attachments to the splitter, except for authorized accessories supplied by the manufacturer with instructions for safe installation and use.
- **Engine speed.** The maximum engine speed is preset at a safe limit. Never attempt to modify the engine speed setting to run at a higher speed.
- **Fuel/exhaust system.** NEVER modify or add to the exhaust system, fuel tanks, or fuel lines. Fire can result.
- **Remote control.** NEVER attach a rope, cable, or other remote device to the splitting control.
- **Splitting wedge.** NEVER attempt to change the height or speed of the splitting wedge.
- **Pressure setting.** NEVER increase the pressure setting of the pump or control valve.
- **Safety equipment / controls.** Always operate the log splitter with all safety equipment in place and in good working order, and all controls properly adjusted for safe operation.
- **Know how to stop.** Be thoroughly familiar with all controls and with the proper use of the equipment. Know how to stop the log splitter and relieve system pressures quickly if needed.
- **Operating speed.** Always operate the log splitter at the manufacturer's recommended speed. The maximum speed of the engine pump and wedge are preset within safe limits.
- **Daylight only.** Only use the log splitter in daylight so you can see what you are doing.
- **Smoking / sparks.** Never smoke while operating the log splitter, and never operate near sources of sparks or flames.
- **Under the influence.** Never operate, or let anyone else operate, the log splitter while under the influence of alcohol, drugs, or medication.
- **Unattended.** Never leave the machine unattended while the engine is running.
- **Refueling.** Never refuel the engine until it has cooled at least two minutes.
- **Adjusting / repairing.** Always make sure the engine is off before cleaning, repairing or adjusting the splitter, except as recommended by the manufacturer. In addition, disconnect the spark plug and move all control handles back and forth to relieve system pressure *before changing or adjusting hydraulic system components* such as hoses, tubing, fittings or other components.
- **Replace labels.** Always make sure safety labels are in place and in good condition. If a safety label is missing or not legible, order new labels because unsafe operation can result. Call 1-800-270-0810 to order new safety labels.

Splitting Operation

1. Put on protective clothing / gear

Wear the following protective clothing and safety gear:

- 1) **Eye protection.** Always wear safety glasses or goggles when operating the machine. Pieces of log may fly out and serious eye injury can occur.
- 2) **Boots.** Falling logs can crush feet. Always wear safety shoes or heavy boots when operating or helping to load logs.
- 3) **Gloves.** Wear snug fitting gloves without drawstrings or loose cuffs.
- 4) **Hearing protection.** The use of earplugs or other hearing protection device is recommended.
- 5) **No loose/dangling.** Loose or dangling apparel can become entangled in moving parts. Never wear jewelry or loose-fitting clothing.

2. Lock and block

Block the wheels to prevent unintended movement of the log splitter. Check that:

- 1) The outrigger legs are both locked in the DOWN position.
- 2) The wheels are blocked.

3. Set to horizontal or vertical:

Set log splitter into either the horizontal or vertical splitting position

The HORIZONTAL splitting position is used for lighter logs that can be easily loaded onto the beam. The VERTICAL splitting position is used for light logs as well as heavy logs that are difficult to load onto the beam.

Note:

Musculoskeletal injury can result from lifting logs onto the log splitter if proper lifting techniques are not used or the logs are too heavy for a person's size, weight, or strength. In some cases, logs as small as 8" in diameter and 14" in length may be heavier than what some persons should be repeatedly lifting onto the splitter.

The use of the vertical splitting position can greatly reduce the need to lift logs onto the splitter. Employers are advised to consider NIOSH lifting guidelines when assigning employees to log splitting tasks for an extended period of time.

⚠ WARNING: NEVER change splitting positions with the engine running. You may contact the muffler and receive serious burns.

a) Set to Horizontal position

Make sure beam is locked securely in the horizontal position by checking the horizontal lock. Jack must be locked in the down position. Rear outrigger leg must be locked in horizontal splitting position.

Horizontal Splitting Position

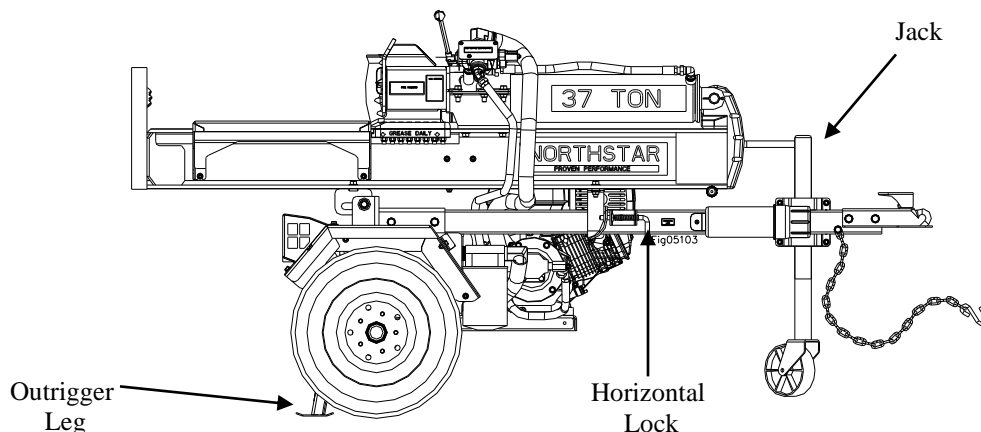

Splitting Operation

b) Set to
Vertical
position

- 1) Lock rear outrigger leg in down position.
- 2) Pull out horizontal lock catch pin, grasp lifting handle and lift beam until it rotates into vertical position.

⚠ WARNING: Crush hazard. The beam is heavy – do not let it just drop. It could crush fingers or cause damage to the splitter.

Vertical Splitting Position

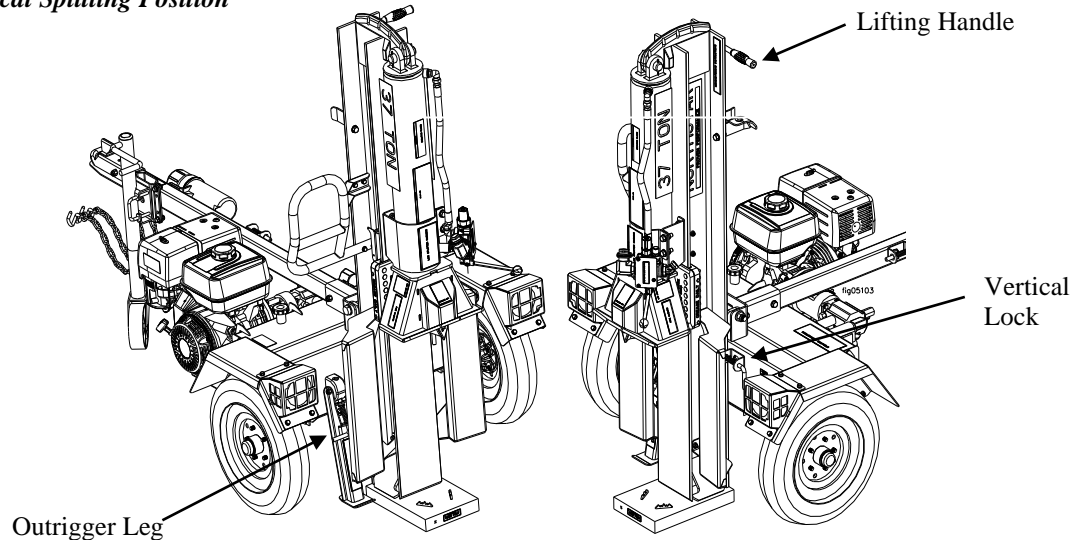

- 3) Lock in vertical position using catch pin through the vertical lock.
- 4) To return to horizontal position, unlock vertical position, grasp lifting handle and lower beam carefully in a controlled manner until it rests on the tow bar, lock beam in the horizontal position with catch pin.

4. Start engine

Start the engine.

See the engine owner's manual for engine starting instructions.

NOTE:

- a) Make sure the hydraulic oil is above 10°F before starting the engine. Cold hydraulic oil can damage the hydraulic pump.
- b) If outdoor air temperature is below 32°F, allow log splitter to warm up by extending and returning the wedge several times before splitting wood.

⚠ WARNING:

- **Burns.** To avoid burns, stay clear of hot muffler if you are starting a warm engine.
- **Carbon monoxide.** The running engine gives off carbon monoxide, a poisonous gas that can kill you. You CANNOT smell it, see it, or taste it. If you start to feel sick, dizzy, or weak while using the log splitter, shut off the engine and get to fresh air RIGHT AWAY. See a doctor. You may have carbon monoxide poisoning.
- **Other exhaust dangers.** Engine exhaust, some of its constituents, and certain vehicle components contain or emit chemicals known to the State of California to cause cancer, birth defects, or other reproductive harm. Avoid inhalation of exhaust.

Splitting Operation

5. Load log

Load log onto beam with a cut end against the endplate – positioned for a lengthwise cut.

Notes:

- The log splitter is designed only for cutting lengthwise with the grain, NOT for cutting across the grain.
- This log splitter is designed for cutting logs only up to a maximum of 16" in diameter and 25" long. Larger diameter logs could get stuck on the wedge and longer logs will not fit on the beam.

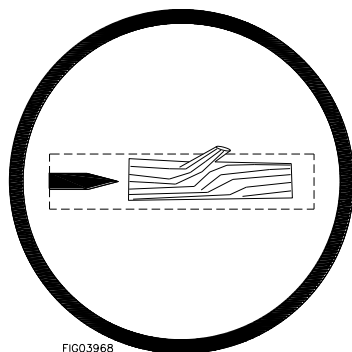
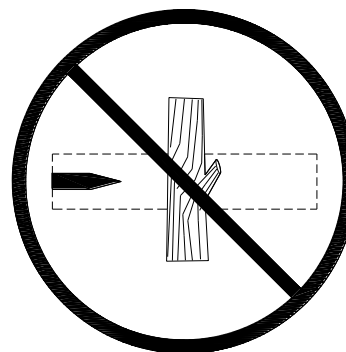
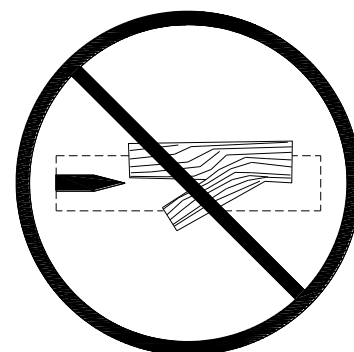

FIG03968

Correct Log Orientation



Incorrect Log Orientation



⚠ WARNING: ALWAYS keep hands and feet away from the endplate, wedge, and partially split logs while loading, operating and unloading the log splitter.

Important safety instructions:

- **Hold bark side.** Hold the bark side of logs when loading or positioning, never the ends. Never place your hands or any part of your body between a log and any part of the log splitter.
- **NOTE for vertical position loading:** Place the log on the endplate and turn it until it leans against the beam and is stable. If the log is too big or oddly shaped, stabilize the log with wooden shims between the log and endplate or ground. DO NOT use your leg or knee to stabilize the log. NEVER stabilize the log by placing your hand on top of the log.
- **Wedge moving.** NEVER load or unload logs while the wedge is moving.
- **Straddling / reaching across.** Never straddle, reach across, or step over the beam while the engine is running and the log splitter is in the horizontal position. You could trip, actuate the controls, and get seriously injured.
- **Unsplit log pile.** Do not pile logs to be split in a place that will make you reach across the log splitter in order to load them.
- **Square log ends.** Logs that are not cut square can slide out while splitting and become a safety hazard or cause excessive force to log splitter components. Use a chainsaw to cut logs square on each end before attempting to split them.
- **Single log.** Never attempt to split more than one log at a time. Pieces of log can unexpectedly be thrown from the machine causing serious injury.
- **Split along grain.** Do not use the log splitter to split logs across the grain. Doing so will damage the log splitter and could also cause pieces of log to be thrown, injuring the operator or bystanders.
- **Forked logs.** Splitting forked logs can cause damage the log splitter. Trim the forked log with a chain saw prior to splitting the log.
- **Changing splitting position.** Do not change splitting positions (horizontal/vertical) with the engine running. You may contact the muffler and receive serious burns. Be careful to avoid contact with hot muffler even after the engine is turned off.

Splitting Operation

6. Extend wedge

Move Split Control Lever toward endplate to extend wedge and split log.

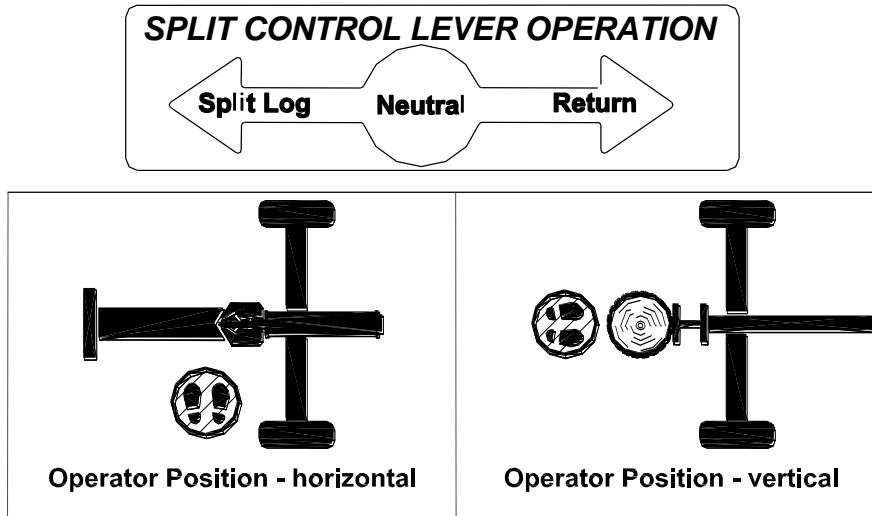

Important safety instructions:

- **Operator position.** ALWAYS operate the log splitter from the manufacturer's indicated OPERATOR POSITION. (See diagram above.) Other positions are unsafe because they can increase the risk of injury from crushing, cutting, flying objects, or burns.
- **Remove hands.** Remove both hands from log before activating Split Control Lever.
- **Hand activate.** Use only your hand to operate the Split Control Lever. Never use any other body part, or a rope, cable, or other remote device to actuate the control.
- **Second person.** Many accidents occur when there is more than one person involved in loading and operating the log splitter. Only one person should operate the controls. *If a second person is assisting in loading logs, the operator must NEVER actuate the Split Control Lever until the assistant and all bystanders are at least 10 feet away. NEVER allow an assistant to hold the log in place while the operator actuates the Split Control Lever.*

7. Stop wedge

Release Split Control Lever to stop wedge movement when log is split.

⚠ WARNING: Cracks in logs can close quickly and pinch fingers. Keep fingers away from any cracks that open in partially split logs.

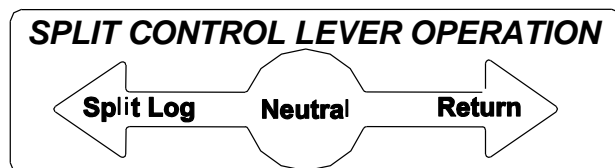

8. Important STUCK LOG procedure

If a log does not split completely and becomes stuck on the wedge, follow the instructions below to remove the log.
 A log can become stuck to the wedge if the wedge becomes embedded in the log and the log doesn't split and separate. This can happen if the log is too stringy or tough to split completely. A stuck log will move back with the wedge on the initial attempt to retract the wedge. If this happens, retract the wedge completely to allow the splitter to strip the log from the wedge. Keep hands clear of log and wedge while wedge is retracting.

Splitting Operation

⚠️ WARNING: NEVER attempt to remove a stuck log by:

- Modifying the splitter.
- Adding attachments to the splitter.

Personal injury could result from log or metal pieces flying out at high speed toward the operator or bystanders, or the splitter could become damaged.

9. Return wedge

Move Split Control Lever away from end plate to return wedge.

Once the control valve is actuated in the return direction, the wedge is designed to keep returning by itself completely and then stop automatically.

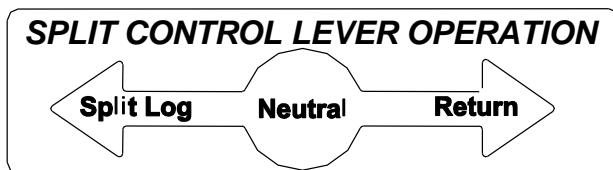

⚠️ WARNING:

Stay clear while the wedge is returning. It is still powerful enough on the return stroke to cause serious injury.

10. Remove split wood

Remove split wood from area.

Move each log away from log splitter after it is split. Split logs left near the log splitter are a trip hazard.

11. After use

1. Turn off engine.

2. Remove engine debris.

Debris on a hot engine can be a fire hazard. After the engine is off, clean debris and chaff from engine cylinder head, cylinder head fins, blower housing rotating screen, and muffler areas.

⚠️ WARNING: Avoid contact with hot muffler.

3. Return to horizontal position.



If in the vertical position, return log splitter to the horizontal position for greater stability and to prepare for transportation. Avoid contact with hot muffler.

Storage

WARNING

Gasoline vapors can ignite and cause a fire. Select a well-ventilated storage away from sources of heat, flame, or sparks.

Follow the instructions below for storing your log splitter between uses.

1. Retract wedge	Retract the wedge completely to keep the rod protected from corrosion.
2. Cool	Allow the machine to cool 5 minutes before storing.  WARNING: A hot engine can be a fire hazard.
3. Wipe with oily rag	Wipe the beam and wedge with an oily rag to prevent corrosion.
4. Engine manual	Refer to the engine manual for proper engine storage instructions. CAUTION: Gasoline will oxidize and deteriorate in storage. Old gasoline in the engine will cause hard starting and leave gum deposits that can clog the fuel systems. Deterioration problems may occur within a few months, or even less if gasoline was not fresh when you filled the tank. <u>Short-Term Storage:</u> <ol style="list-style-type: none"> 1. Consider adding a fuel stabilizer to extend fuel storage life. 2. Leave the fuel valve lever in the OFF position to reduce the possibility of fuel leakage. <u>Long-Term Storage:</u> (between infrequent uses and at end of season) Drain the fuel tank and carburetor as instructed in the engine owner's manual. <u>Important Safety Instructions</u> <ul style="list-style-type: none"> • Always drain fuel from tank in outdoor, well-ventilated area. • Stay away from sources of heat, flame, or sparks while handling fuel. • Clean up fuel spills/splashes immediately.
5. Splitter storage location	Store the log splitter in a location away from corrosive material, sources of heat, open flames, sparks or pilot lights.  WARNING: Never store log splitter inside where there is a source of heat or an open flame, spark or pilot light – such as water heaters, space heaters, furnaces, clothes dryers, or other gas appliances – EVEN IF the log splitter's gas tank is empty, residual gasoline vapors could ignite. <u>NOTE:</u> Do not store the log splitter near fertilizer or any other corrosive material.
6. Gasoline storage	Store gasoline in a cool, dry place in an UL listed tightly sealed container.  WARNING: Gasoline vapors can ignite if they collect inside an enclosure and explosion can result.

Periodic Maintenance

In addition to the maintenance performed with each use, periodic maintenance should also be performed according to the following schedule.

⚠ WARNING

ALWAYS shut off the engine, disconnect the spark plug, and relieve system pressure before cleaning, adjusting, or repairing the splitter. Relieve system pressure by moving Split Control Lever back and forth several times.

IMPORTANT:

If a part needs replacement only use parts that meet the manufacturer's specifications. Replacement parts that do not meet specifications may result in a safety hazard or poor operation of the log splitter.

1. Engine maintenance	Perform engine maintenance as specified in engine owner's manual.
2. Hydraulic Oil Change	<p>Change Hydraulic Oil Annually or Every 100 Hours.</p> <p>⚠ WARNING: High fluid pressures and temperatures are developed in hydraulic log splitters. Hydraulic fluid escaping through a pin hole sized opening can burn or puncture skin, resulting in wounds that could cause blood poisoning, infection, disability, gangrene, amputation, or death. Therefore, the following instructions should be heeded at all times when inspecting or servicing the hydraulic components of the log splitter.</p> <ul style="list-style-type: none"> • NEVER check for leaks with your hand. Leaks can be located by holding a piece of cardboard or wood (at least two feet long) with your hand at one end and passing the other end over the suspected area (wear eye protection). Look for discoloration of the cardboard or wood. • NEVER adjust the pressure of the pump or valve. • If injured by escaping fluid, no matter how small the wound is, see a doctor at once. A typical injection injury may be a small wound that does not look serious. However, severe infection or reaction can result if proper medical treatment is not administered immediately by a doctor who is familiar with injection injuries. <ol style="list-style-type: none"> 1. Use 10wt AW32, ASLE H-150, or ISO32 oil. 2. Relieve hydraulic system pressure by moving Split Control Lever back and forth several times. 3. Remove hydraulic breather cap/oil dipstick <p>⚠ WARNING: NEVER remove the hydraulic breather cap/oil dipstick when the engine is running or hot. Hot oil can escape causing severe burns. Allow the log splitter to cool completely before removing hydraulic breather cap/oil dipstick.</p> 4. Remove the magnetic drain plug from the hydraulic tank to drain the hydraulic oil into a 15 gallon pan. 5. Remove suction strainer and wipe off debris with a dry cloth. 6. Fill the hydraulic tank with wedge retracted. 7. Dispose of used oil at an oil-recycling center. Used hydraulic oil is hazardous waste. 8. Disconnect the spark plug wire from the spark plug 9. Pull on the starter grip recoil at least 20 times so that hydraulic fluid has cycled through the pump 10. Reconnect the spark plug wire to the spark plug 11. Extend and retract wedge 5 (five) times to purge air from the system. 12. Check hydraulic oil level and fill if necessary. Note: Do not thread in the oil dipstick when checking the hydraulic oil level.
3. Spark arrestor muffler	If the engine is equipped with a spark arrestor muffler, clean and inspect it regularly (follow manufacturer's service instructions). Replace if damaged.

Troubleshooting

⚠ WARNING

Before troubleshooting or attempting to service, read the following safety instructions to avoid serious injury to the operator or bystanders from moving parts that can crush or cut, burns, fire or explosion, or escaping high pressure hydraulic fluid.

Important Safety Instructions:

1. **Engine off.** Always make sure the engine is off before cleaning, repairing or adjusting the splitter, except as recommended by the manufacturer.
2. **Hydraulic safety.** High fluid pressures and temperatures are developed in the hydraulic log splitters. Hydraulic fluid escaping through a pin hole sized opening can burn or puncture skin, resulting in wounds that could cause blood poisoning, infection, disability, gangrene, amputation, or death. Therefore, the following instructions should be heeded at all times when inspecting or servicing the hydraulic components of the log splitter:
 - Stop the engine, disconnect the spark plug, and move all control valve handles back and forth to relieve pressure before changing or adjusting hydraulic components such as hoses, tubing, fittings, or other components.
 - Do not remove the hydraulic oil fill cap when the engine is running. Hot oil can escape causing severe burns. Allow the log splitter to cool completely before removing the hydraulic oil fill cap.
 - Do not adjust the pressure setting to the pump or valve.
 - Do not check for leaks with your hands. Leaks can be located by holding a piece of cardboard or wood (at least 2 feet long) with your hand at one end and passing the other end suspected area (wear eye protection). Look for discoloration of the cardboard or wood.
 - If injured by escaping fluid, no matter how small the wound is, see a doctor at once. A typical injection injury may be a small puncture that does not look serious. However, severe infection or reaction can result if proper medical treatment is not administered immediately by a doctor who is familiar with injection injuries.

Problem	
Wedge will not move	Solution: A,D,E,H,J
Slow wedge speed when extending or retracting	Solution: A,B,C,H,I,K
Wood will not split or splits extremely slow	Solution: A,B,C,F,I,K
Engine bogs down during splitting	Solution: G
Engine stalls under low load condition	Solution: D,E
Cause	Solution
A- Insufficient oil to pump	Check oil level in reservoir
B- Air in oil	Check oil level in reservoir, check for leaks in the suction line
C- Excessive pump inlet vacuum	Check pump inlet hose for blockage or kinks
D- Blocked hydraulic lines	Flush and clean the splitter hydraulic system
E- Blocked control valve	Flush and clean the splitter hydraulic system
F- Low control valve setting	Adjust control valve with a pressure gauge
G- High control valve setting	Adjust control valve with a pressure gauge
H- Damaged control valve	Return control valve for authorized repair
I- Internal control valve leak	Return control valve for authorized repair
J- Damaged cylinder piston	Return cylinder for authorized repair
K- Internally damaged cylinder	Return cylinder for authorized repair

Any Questions, Comments, Problems or Parts Orders

Call NorthStar Product Support 1-800-270-0810

Specifications

	1118
Tonnage	37 TON
Pressure	3500 PSI
Flow	16 GPM
Hydraulic Cylinder Bore	5"
Hydraulic Cylinder Stroke	24"
Maximum Log Length	25"
Maximum Log Width	16"
Hydraulic Fluid Type	10wt AW32, ASLE H-150, or ISO32
Hydraulic Oil Capacity	15 GAL
Coupler Size	2" Ball
Maximum Towing Speed	45 MPH
Spark Arrester	Yes
Fuel Valve	Yes
Overall Dimensions	92" x 45" x 45" (LxWxH)
Dry Weight	675 LBS

The manufacturer reserves the right to make improvements in design and/or changes in specifications at any time without incurring any obligation to install them on units previously sold.

Any Questions, Comments, Problems or Parts Orders
Call NorthStar Product Support 1-800-270-0810

Parts Breakdown – Exploded View 1118 – Rev G.1

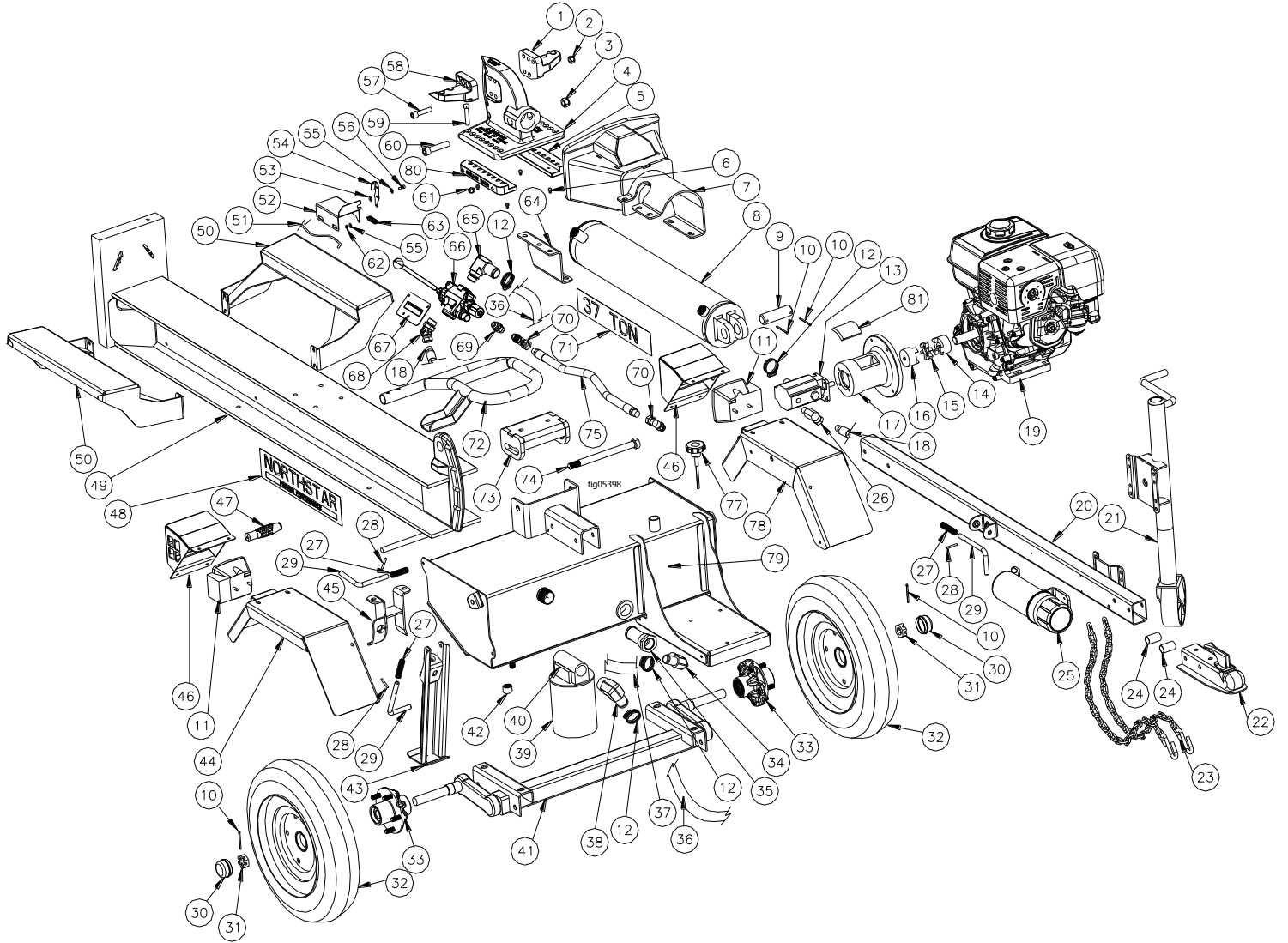

Parts Breakdown – Exploded View 1118 – Rev G.1

Ref#	Part#	Desc	Qty
1	784029	Wedge Wing, Right	1
2	82037	1/2-13 Nylon Nut	5
3	82332	5/8-11 Nylon Nut	1
4	788263	Wedge	1
5	783968	Wedge Keeper, Right	1
6	778873	Grease Zerk	4
7	790447	Dislodger/Log Stripper	1
8	790399	5" x 24" Cylinder	1
9	778592	Cylinder Pin	1
10	778674	Cotter Pin	4
11	789590	Trailer Light Kit	1
12	777835	Hose Clamp, 13/16"-1-3/4"	4
13	804105	Hydraulic Pump, 16 GPM	1
14	777911	Coupling 1"	1
15	777912	Coupling Insert	1
16	777909	Coupling 1/2"	1
17	779683	Pump Bracket	1
18	790489	High Pressure Hose 1/2" ID x 56" Long	1
19	601091	Engine, Honda GX390	1
20	790473	Towbar	1
21	791311	Jack	1
22	778423	2"Ball/Coupler	1
23	1130	Safety Chain	2
24	791545	Towbar Spacer	2
25	788040	Manual Tube	1
26	50RAS8	1/2" M x 1/2" F 90° Elbow	1
27	788245	Latch Spring	3
28	788244	Latch Rod Pin	3
29	788243	Latch Rod	3
30	124A	Dust Cap	2
31	777124	Castle Nut	2
32	791172	Tire	2
33	794906	Hub	2
34	788504	1" NPT x 1" HB Elbow	1
35	790470	Strainer 1" FPT x 1.5" MPT	1
36	790486	Hose, 1.25" ID x 69"	1
37	791312	Low Pressure Hose, 1" ID x 8.5"	1
38	790487	1.25 NPT x 1.25" HB	1
39	791248	Return Line Filter - Lg	1
40	791245	Filter Head-Lg	1
41	788085	Torsion Axle	1
42	790064	1/2" Magnetic Hex Plug	1
43	790926	Outrigger Leg	1
44	790752	Right Fender	1
45	790548	Horizontal Beam Lock	1
46	792414	Light Housing	2
47	778459	Hand Grip	1
48	790776	Decal, Northstar Branding	2
49	790710	Beam	1
50	790562	Log Cradle	2
51	791382	Idle Control Cable	1
52	788264	Throttle Bracket	1
53	31095	1/4" Nylon Washer	1

Ref#	Part#	Desc	Qty
54	778470	Idle Control Arm	1
55	31094	1/4" Brass Washer	2
56	82058	1/4" x 1/4" Shoulder Bolt	1
57	82575	1/2-13 x 2-1/4" SHCS	5
58	784030	Wedge Wing, Left	1
59	82467	7/16-14 x 2-1/4 Hex Bolt	16
60	82468	5/8-11 x 2-3/4 Socket Bolt	1
61	82115	7/16-14 Nylon Nut	16
62	82065	#10-24 Nylon Nut	1
63	791408	Extension Spring	1
64	790444	Gusset	1
65	789051	90° 12MOR x 1.25" HB	1
66	791869	Valve	1
67	791187	Valve Plate	1
68	791219	12 MOR-8 FP x 45°	1
69	790488	8MOR x MOR Adj.	1
70	778827	8MOR x 8 FP x 90°	2
71	790808	37 Ton Decal	2
72	803779	Engine Guard	1
73	790623	Pivot Bracket	1
74	790746	Pivot Pin	1
75	778619	HP Hose 1/2" ID x 25"	1
77	784470	Breather Cap/Oil Dipstick	1
78	790754	Left Fender	1
79	790490	Hydraulic Tank	1
80	783969	Wedge Keeper, Left	1
81	779681	Guard Insert	2
81	779681	Guard Insert	2

Summary of Important Safety information for Operation

WARNING

Carefully read and make sure you understand the following safety information before using the log splitter. Improper use or maintenance of the log splitter can result in serious injury to the operator or bystanders from moving parts that can crush or cut, flying objects, burns, fire or explosion, escaping high pressure hydraulic fluid, or carbon monoxide poisoning.

Introduction

- **Read Manual.** Read this operator's manual and the engine Owner's Manual completely before attempting to use the log splitter. Serious injury or death can result if safety instructions are not followed.
- **Instruct operators.** The log splitter owner should instruct all operators in safe log splitter operation.
- **Intended use.** Log splitters should only be used for splitting wood logs, lengthwise with the grain. Do not use for other purposes, as unforeseen hazards may result.

Prohibition Against Modifications

Never modify or alter the log splitter in any way. Modifications can create serious safety hazards and will void the warranty.

- **Attachments.** Never add attachments to the splitter, except for authorized accessories supplied by the manufacturer with instructions for safe installation and use.
- **Engine Speed.** The maximum engine speed is preset at a safe limit. Never attempt to modify the engine speed setting to run at a higher speed.
- **Fuel/Exhaust system.** NEVER modify or add to the exhaust system, fuel tanks, or fuel lines. Fire can result.
- **Remote Control.** NEVER attach a rope, cable, or other remote device to the splitting control.
- **Splitting Wedge.** NEVER attempt to change the height or speed of the splitting wedge.
- **Pressure Setting.** NEVER increase the pressure setting of the pump or control valve.

Operator Restrictions

- **Untrained Operators.** Do not allow anyone to operate the log splitter who has not read the owner's manual or been instructed on the safe use of the splitter.
- **Minimum Operator Age.** Never allow anyone under age 16 to operate the log splitter. Anyone 16 years of age and older must be trained and supervised by a trained adult.

Safety in Moving and Towing the Log Splitter

WARNING

The log splitter is very heavy. It can cause serious injury if it rolls out of control or tips over.

Follow the safety instructions below for safely moving the log splitter.

General safety while Moving

- **Horizontal position.** Make sure the log splitter is secured in the horizontal position before moving the log splitter. DO NOT move the log splitter when it is in the vertical position because it will be unstable and could tip.
- **Hills.** Do not move the log splitter up or down hills by hand – use a towing vehicle.
- **Engine off.** Never move the log splitter with its engine running.
- **No riding.** Never allow anyone to sit or ride on the log splitter.
- **No cargo.** Never transport cargo or wood on the log splitter.

Safety During Towing

- **Read instructions.** Review towing safety instructions in your towing vehicle manual.
- **Securely attached.** Be sure the log splitter is securely attached to the towing vehicle before towing.

Summary of Important Safety information for Operation

- **Tires.** Be sure the tires are fully inflated and in good repair before towing the log splitter. When adding air to the tires, do not over-inflate – serious injury could occur if tire explodes.
- **Added length.** Be aware of the added length of the splitter.
- **Speed Limit.** Never tow this log splitter over 45 mph. Faster speeds may result in loss of control.
- **Rough terrain.** Be extra cautious and drive slowly when traveling over rough terrain.
- **Under the influence.** Never tow this splitter while under the influence of alcohol, drugs, or medication.
- **On public roads.** If towing on a public road, make sure to comply with all local, state, and federal towing requirements. It is the sole responsibility of the purchaser to obtain licensing, trailer lights, safety chains or signage, as needed to comply.
- **Unattended.** Turn off the towing vehicle before leaving the splitter unattended.
- **Disconnect before operate.** Do not use the log splitter while it is connected to the towing vehicle.

Safety – Before Use

Read/instruct

- **Read manual.** Do not allow anyone to operate the log splitter who has not read the owner's manual or has not been instructed on the safe use of the splitter.
- **Review safety rules.** Before starting this log splitter, review the "Rules for Safe operation." Failure to follow these rules may result in serious injury to the operator or bystanders.
- **Know how to stop.** Be thoroughly familiar with all controls and proper use of the equipment. Know how to stop the splitter and relieve system pressures quickly if needed.

Personal protective equipment

- **Eye protection.** Always wear safety glasses or goggles when operating the machine. Pieces of log may fly out and serious eye injury can occur.
- **Boots.** Falling logs can crush feet. Always wear safety shoes or heavy boots when operating or helping to load logs.
- **Loose/dangling.** Loose or dangling apparel can become entangled in moving parts. Never wear jewelry or loose-fitting clothing.
- **Gloves.** Wear snug fitting gloves without drawstrings or loose cuffs.
- **Hearing Protection.** The use of earplugs or other hearing protection device is recommended.

Safety During Inspection/Maintenance

Always inspect your log splitter before each use, and repair as needed, to keep it in safe working condition:

- **Engine off.** Always make sure the engine is off before cleaning, repairing or adjusting the splitter, except as recommended by the manufacturer.
- **Engine debris.** Debris on a hot engine can be a fire hazard. With the engine off, clean debris and chaff from engine cylinder head, cylinder head fins, blower housing rotating screen, and muffler areas. Avoid contact with hot muffler.
- **Other debris.** Debris on moving parts can cause excess wear. With the splitter engine off, clear debris from moving parts.
- **Fuel tank / lines.** Before each use, check fuel tank and fuel lines for leaks. Any fuel leak is a fire hazard. Fix any fuel leaks before starting engine.
- **Mechanical parts.** Check to be sure that all nuts and bolts are tight to make sure the log splitter is in safe working condition.
- **Hydraulic system.** Check the hydraulic system (hoses, tubing, clamps/fittings, pump, and cylinder) carefully before each use. Do not operate the log splitter with frayed, kinked, cracked or damaged hydraulic hoses, fittings, or tubing, or if oily residue is observed on any of the components. High fluid pressures and temperatures are developed in the log splitter. Hydraulic fluid escaping through a pin hole sized opening can burn or puncture skin, resulting in wounds that could cause blood poisoning, infection, disability, gangrene, amputation, or death. Therefore, the following instructions should be heeded at all times when inspecting or servicing the hydraulic components of the log splitter:
 - Do not remove the hydraulic oil dipstick when the engine is running. Hot oil can escape causing severe burns. Allow log splitter to cool completely before removing hydraulic oil dipstick.
 - Do not adjust the pressure setting of the pump or valve.

Summary of Important Safety information for Operation

- o Do not check for leaks with your hand. Leaks can be located by holding a piece of cardboard or wood (at least two feet long) with your hand at one end and passing the other end over the suspected area (wear eye protection). Look for discoloration of the cardboard or wood.
- o Stop the engine, disconnect the spark plug, and move all control valve handles back and forth to relieve pressure before changing or adjusting hydraulic system components such as hoses, tubing, fittings or other components.
- o If injured by escaping fluid, no matter how small the wound is, see a doctor at once. A typical injection injury may be a small puncture wound that does not look serious. However, severe infection or reaction can result if proper medical treatment is not administered immediately by a doctor who is familiar with injection injuries.
- **Spark arrestor muffler.** If the engine is equipped with a spark arrestor muffler, clean and inspect it regularly (follow manufacturer's service instructions). Replace if damaged.
- **Tires.** Be sure tires are fully inflated and in good repair before towing the splitter. When adding air to tires, do not over-inflate -- serious injury could occur if tire explodes.
- **Guards / shields.** Make sure all guards and shields are replaced after servicing the log splitter.
- **Replacement parts.** If a part needs replacement, only use parts that meet the manufacturer's specifications. Replacement parts that do not meet specifications may result in a safety hazard or poor operation of the log splitter.

Safety During Fueling

- **Gasoline is highly flammable and explosive.** You can be burned or seriously injured when handling fuel. Use extreme care when handling gasoline:
- **Fuel outdoors.** Fill fuel tank outdoors – never indoors. Gasoline vapors can ignite if they collect inside an enclosure. Explosion can result.
- **Use approved container.** Never pump fuel directly into engine at gas station. Static charge can build and ignite fuel. Use an UL listed fuel container to transfer gas to the engine.
- **Running / hot engine.** A running engine is hot enough to ignite fuel. Never add fuel or remove gas cap if engine is running or still hot. Stop the engine and allow to cool at least two minutes before adding fuel.
- **Heat / flames / sparks.** Stay away from sources of heat, flame, or sparks while adding fuel.
- **Don't overfill.** DO NOT overfill the gas tank. Allow at least 1/2" of empty space below the fill neck to allow for fuel expansion.
- **Replace cap.** Replace gas cap securely before starting engine.
- **Spills.** Clean up fuel spills immediately. Move log splitter away from spilled fuel on the ground. Wipe fuel off engine and wait 5 minutes for excess fuel to evaporate before starting engine. Gas soaked rags should be disposed of properly.
- **On skin / clothes.** If gasoline is spilled on your skin or clothes, change clothes and wash skin immediately.
- **Gasoline storage.** Store gasoline in a cool, dry place in an UL listed, tightly sealed container.

Safety in Work Site Selection

- **Spark arrestor.** If your splitter will be used near any unimproved forest, brush, or grassy covered land, then engine should be equipped with a spark arrestor. See the "Specifications" section of this manual to determine if your splitter already has a spark arrestor. Make sure you comply with applicable local, state and federal codes.
- **Hot exhaust.** Hot exhaust fumes from engine can cause fire. Position muffler at least 7' from combustible objects during operation.
- **Fire extinguisher.** Have a Class "ABC" rated fire extinguisher available as a precautionary measure when operating the log splitter in dry areas. Keep it properly charged and be familiar with its use.
- **Level, dry surface.** To prevent accidental falls and equipment tip over, make sure the splitter is situated on a dry, level surface with good footing. Stay clear of areas with mud, ice, tall grass, weeds, brush, or snow.
- **Block wheels.** Always block the wheels to prevent unintended movement of the log splitter.
- **Carbon monoxide.** The running engine gives off carbon monoxide, a poisonous gas that can kill you. You CANNOT smell it, see it, or taste it. ONLY run log splitter OUTDOORS and away from air intakes. NEVER run log splitter inside homes, garages, sheds, or other semi-enclosed spaces. These spaces can trap poisonous gases, EVEN if you run a fan or open windows. If you start to feel sick, dizzy, or weak while using the log splitter, shut off the engine and get to fresh air RIGHT AWAY. See a doctor. You may have carbon monoxide poisoning.

Summary of Important Safety information for Operation

Safety – During Use General Safety During Use

⚠ WARNING: Before starting this log splitter, review the following rules for safe operation. Failure to follow these rules may result in serious injury to the operator or bystanders.

- **Safety equipment / controls.** Always operate the log splitter with all safety equipment in place and in good working order, and all controls properly adjusted for safe operation.
- **Operating speed.** Always operate the log splitter at the manufacturer's recommended speed. The maximum speed of the engine, pump and wedge are preset within safe limits.
- **Know how to stop.** Be thoroughly familiar with all controls and with the proper use of the equipment. Know how to stop the log splitter and relieve system pressures quickly if needed.
- **Daylight only.** Only use the log splitter in daylight so you can see what you are doing.
- **Smoking / sparks.** Never smoke while operating the log splitter, and never operate near sources of sparks or flames.
- **Hot muffler.** If you are starting a warm engine, stay clear of muffler. It may still be hot enough to burn you.
- **Unattended.** Never leave the machine unattended while the engine is running.
- **Under the influence.** Never operate, or let anyone else operate, the log splitter while under the influence of alcohol, drugs, or medication.
- **Adjusting / repairing.** Always make sure the engine is off before cleaning, repairing or adjusting the splitter, except as recommended by the manufacturer. In addition, disconnect the spark plug and move all control handles back and forth to relieve system pressure *before changing or adjusting hydraulic system components* such as hoses, tubing, fittings or other components.
- **Carbon monoxide.** The running engine gives off carbon monoxide, a poisonous gas that can kill you. You CANNOT smell it, see it, or taste it. If you start to feel sick, dizzy, or weak while using the log splitter, shut off the engine and get to fresh air RIGHT AWAY. See a doctor. You may have carbon monoxide poisoning.
- **Other exhaust dangers.** Engine exhaust, some of its constituents, and certain vehicle components contain or emit chemicals known to the State of California to cause cancer, birth defects, or other reproductive harm. Avoid inhalation of exhaust.

Safety in Loading, Operating, and Unloading

- **Square log ends.** Logs that are not cut square can slide out while splitting and become a safety hazard or cause excessive force to log splitter components. Use a chainsaw to cut logs square on each end before attempting to split them.
- **Single log.** Never attempt to split more than one log at a time. Pieces of log can unexpectedly be thrown from the machine causing serious injury.
- **Split along grain.** Do not use the log splitter to split logs across the grain. Doing so will damage the log splitter and could also cause pieces of log to be thrown, injuring the operator or bystanders.
- **Forked logs.** Splitting forked logs can cause damage the log splitter. Trim the forked log with a chain saw prior to splitting the log.
- **Keep hands clear.** ALWAYS keep hands and feet away from the endplate, wedge, and partially split logs while loading, operating and unloading the log splitter.
- **Operator position.** ALWAYS operate the log splitter from the manufacturer's indicated OPERATOR POSITION. Other positions are unsafe because they can increase the risk of injury from crushing, cutting, flying objects, or burns.
- **Straddling / reaching across.** Never straddle, reach across, or step over the beam while the engine is running and the log splitter is in the horizontal position. You could trip, actuate the controls, and get seriously injured.
- **Second person.** Many accidents occur when there is more than one person involved in loading and operating the log splitter. Only one person should operate the controls. *If a second person is assisting in loading logs, the operator must NEVER actuate the Split Control Lever until the assistant and all bystanders are at least 10 feet away. NEVER allow an assistant to hold the log in place while the operator actuates the Split Control Lever.*

Summary of Important Safety information for Operation

Loading/Unloading

- **Unsplit log pile.** Do not pile logs to be split in a place that will make you reach across the log splitter in order to load them.
- **Hold bark side.** Hold the bark side of logs when loading or positioning, never the ends. Never place your hands or any part of your body between a log and any part of the log splitter.
- **NOTE for vertical position loading:** Place the log on the endplate and turn it until it leans against the beam and is stable. If the log is too big or oddly shaped, stabilize the log with wooden shims between the log and endplate or ground. DO NOT use your leg or knee to stabilize the log. NEVER stabilize the log by placing your hand on top of the log.
- **Wedge moving.** NEVER load or unload logs while the wedge is moving.
- **Cracks.** Cracks in logs can close quickly and pinch fingers. Keep fingers away from any cracks that open in partially split logs.
- **Split log pile.** Move each log away from log splitter after it is split. Split logs left near the log splitter are a trip hazard.
- **Remove hands.** Remove both hands from log before activating Split Control Lever.
- **Hand activate.** Use only your hand to operate the Split Control Lever. Never use any other body part, or a rope, cable, or other remote device to actuate the control.
- **Returning wedge.** Once the control valve is actuated in the return direction, the wedge is designed to keep returning by itself completely and then stop automatically. Stay clear while the wedge is returning. It is still powerful enough on the return stroke to cause serious injury.
- **Log stuck on wedge.** If a log does not split completely and becomes stuck on the wedge, follow the instructions below to remove the log. A log can become stuck to the wedge if the wedge becomes embedded in the log and the log doesn't split and separate. This can happen if the log is too stringy or tough to split completely. A stuck log will move back with the wedge on the initial attempt to retract the wedge. If this happens, retract the wedge completely to allow the splitter to strip the log from the wedge. Keep hands clear of log and wedge while wedge is retracting.

⚠ WARNING: NEVER attempt to remove a stuck log by:

- Modifying the splitter.
- Adding attachments to the splitter.

Personal injury could result from log or metal pieces flying out at high speed toward the operator or bystanders, or the splitter could become damaged.

- **Changing splitting position.** Do not change splitting positions (horizontal/vertical) with the engine running. You may contact the muffler and receive serious burns. Be careful to avoid contact with hot muffler even after the engine is turned off.
- **Refueling.** Never refuel the engine until it has cooled at least two minutes.

Safety – After use

- **Return to horizontal.** If in the vertical position, turn off engine and return log splitter to the horizontal position for greater stability and to prepare for transportation. Avoid contact with hot muffler.
- **Remove engine debris.** Debris on a hot engine can be a fire hazard. With the engine off, clean debris and chaff from engine cylinder head, cylinder head fins, blower housing rotating screen, and muffler areas. Avoid contact with hot muffler.
- **Let engine cool before storing.** Let engine cool for at least five minutes before storing. A hot engine can be a fire hazard.
- **Storage location.** Store the log splitter in a location away from sources of heat, open flames, sparks or pilot lights – such as water heaters, space heaters, furnaces, clothes dryers, or other gas appliances. Even if the log splitter's gas tank is empty, residual gasoline vapors could ignite.
- **Gasoline storage.** Store extra gasoline in a cool, dry place in an UL listed, tightly sealed container. Gasoline vapors can ignite if they collect inside an enclosure.
- **Periodic maintenance.** Perform periodic maintenance as directed in this manual to keep the log splitter in safe working condition.

Assembly Instructions

Remove all components from the shipping container. Using this manual, identify and sort components as necessary.

Closely inspect all log splitter components.

If you have missing or damaged components, please contact Product Support at 1-800-270-0810.

Find a work space that is large enough to maneuver log splitter once completely assembled. Assemble log splitter on solid and level ground.

CAUTION! Heavy lifting required. Some of the components in these assembly instructions are heavy and cannot be lifted by one person safely. Please plan on assembling this product when another person can be available to help out.

CAUTION! Hose clamp orientation. When assembling hose clamps, orient the runout-tab so that it is out of the way of any interaction points on the log splitter

Tools needed: Adjustable wrenches, Torque Wrench, Soft Faced Mallet, Flat Blade Screw Driver, Socket & Ratchet

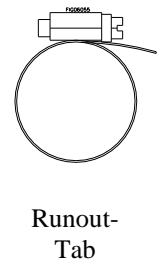
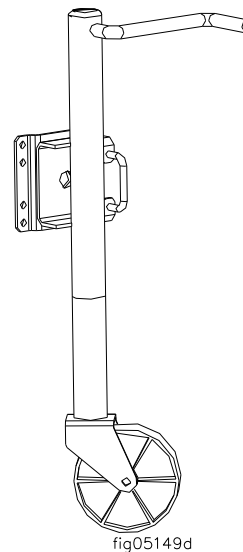
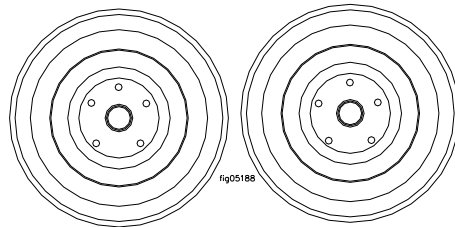
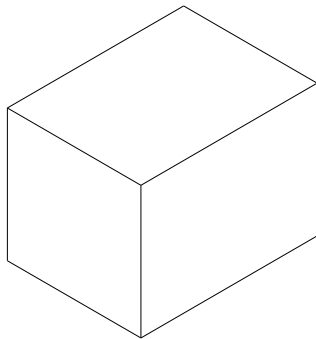
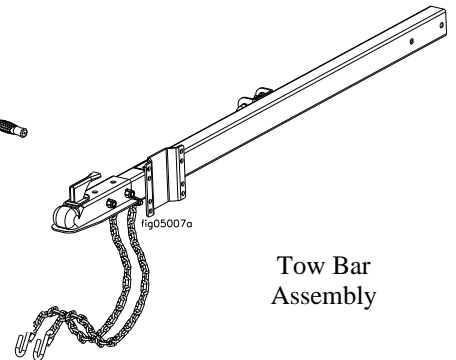
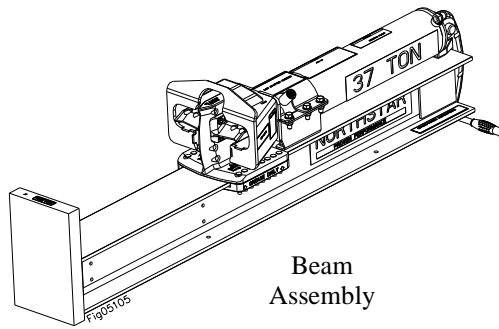
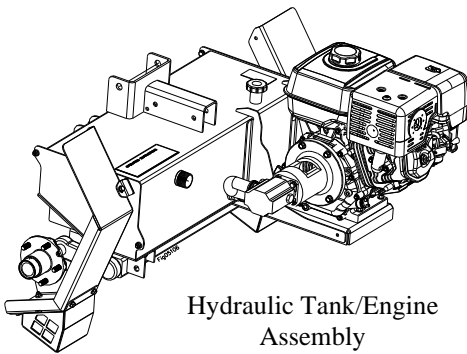

Assembly Instructions

Parts Bag:

fig05154

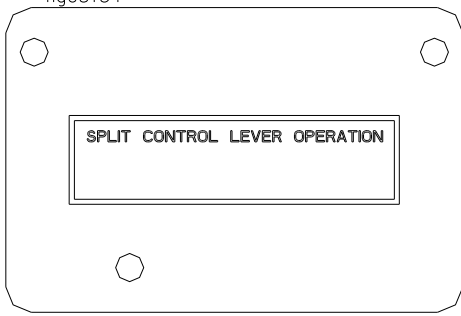

Valve Plate
Part # 791187
Qty 1

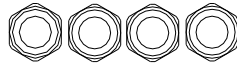

Engine Guard to Beam
Part# 777495
M8-1.25 Nyloc Nut
Qty 4

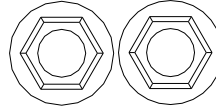

Horizontal Latch to Beam
Part# 82273
M12-1.75 HHSF Nut
Qty 2

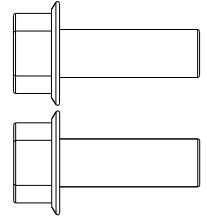

Beam to Pivot Bracket
Part# 82551
M12-1.75 X 35 HHSF Bolt
Qty 2



Engine Guard to Beam
Part# 777496
M8 Flat Washer
Qty 3



Valve Plate
Part# 82563
M6-1.0 Nyloc Nut
Qty 3

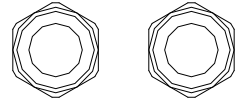

Beam to Pivot Bracket
Part# 82272
M12-1.75 Nyloc Nut
Qty 2



Jack to Tow Bar
Part# 82270
M10-1.5 Nyloc Nut
Qty 4



Out Rigger to Tank
Part# 82270
M10-1.5 Nyloc Nut
Qty 1



Out Rigger to Tank
Part# 82201
M10 Flat Washer
Qty 1

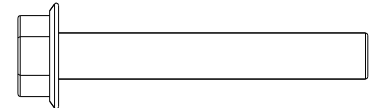

Tow Bar to Tank
Part# 82569
M12-1.75 X 80 HHSF Bolt
Qty 2



Tow Bar to Tank
Part# 82287
1/4\" x 3/4\" Self-Drilling Screw
Qty 1

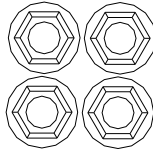

Log Cradles to Beam
Part# 82281
M8-1.25 HHSF Nut
Qty 4

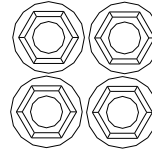

Fenders to Tank
Part# 82281
M8-1.25 HHSF Nut
Qty 4

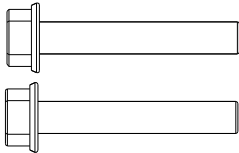
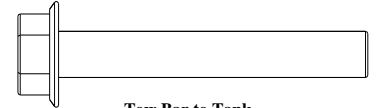

Engine Guard to Beam
Part# 82565
M8-1.25 x 50mm HHSF Bolt
Qty 2

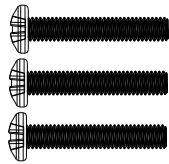

Valve Plate
Part# 82562
M6-1.0 x 35mm PHCS, Zinc
Qty 3



Out Rigger to Tank
Part# 82574
M10-1.5 x 70 HHSF Bolt
Qty 1

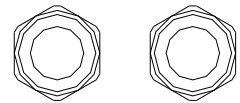

Tow Bar to Tank
Part# 82272
M12-1.75 Nyloc Nut
Qty 2

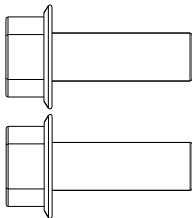

Horizontal Latch to Beam
Part# 82551
M12-1.75 x 35 HHSF Bolt
Qty 2

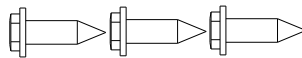

Manual Tube
Part# 82529
M6 x 20mm Self Tapping
Screw
Qty 3

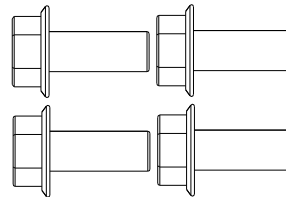

Jack to Tow Bar
Part# 82262
M10-1.5 x 25 HHSF Bolt
Qty 4

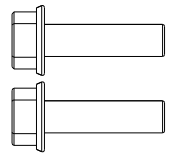

Throttle Bracket to Beam
Part# 82292
M8-1.25 X 20 HHSF Bolt
Qty 2

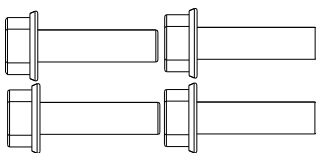

Fender to Tank
Part# 82292
M8-1.25 x 20 HHSF
Qty 4

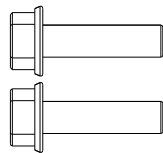

Engine Guard to Beam
Part# 82545
M8-1.25 x 30mm HHSF Bolt
Qty 2

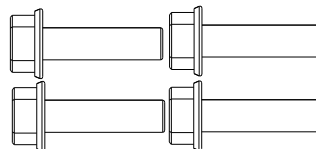

Log Cradles to Beam
Part# 82545
M8-1.25 x 30 HHSF Bolt
Qty 4

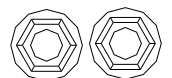

Throttle Bracket to Beam
Part# 82281
M8-1.25 HHSF Nut
Qty 2

Assembly Instructions

Parts Bag Continued:

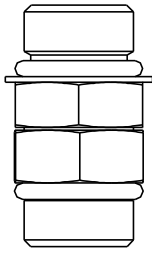

Cylinder to Valve Fitting
Part# 790488
8MOR x 8 MOR Adj Fitting
Qty 1

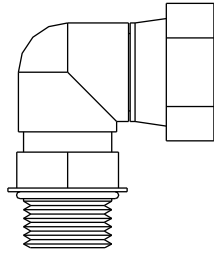

Valve to Cylinder Fitting
Part# 778827
O-Ring x FNPT Swivel Elbow, 8-8
Qty 1

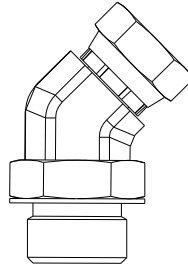

Valve to Hydraulic Pump Fitting
Part# 791219
12 MOR- 8 FP x 45 Forged
Qty 1

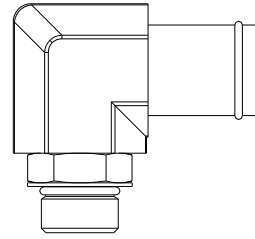

Valve to Hydraulic Filter Fitting
Part# 789051
12 MOR x 1.25 HB
Qty 1

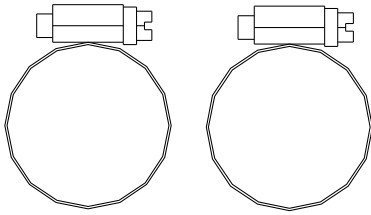

Tank to Pump Hose Clamps
Part# 777935
13/16" to 1-3/4" Hose Clamp
Qty 2

Owner's Manual Bag:

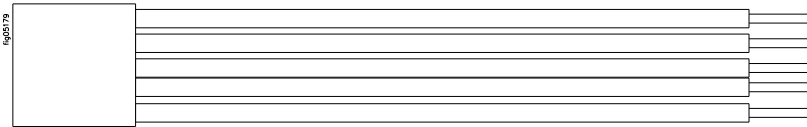

Light Wiring and Hardware
Part# 789590
Qty 1

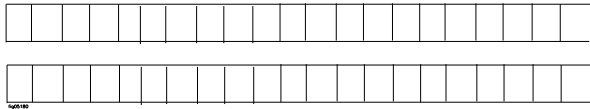

Black Plastic Loom
Part# 777135
Qty 2 x 16"

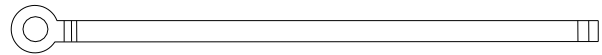

White Ground Wire
Part# 779798
Qty 1

Assembly Instructions

Log Splitter Box:

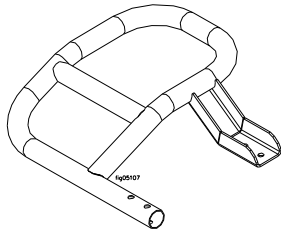

Engine Guard

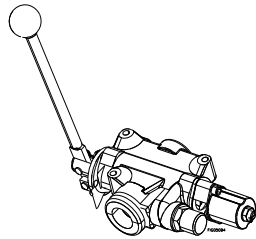

Hydraulic Valve



Owner's Manual Bag

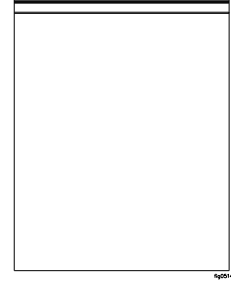

Parts Bag

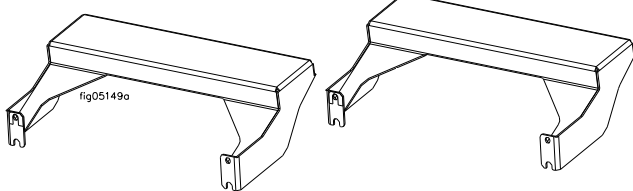

Log Cradles
Qty 2

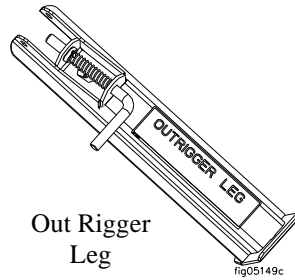

Out Rigger
Leg

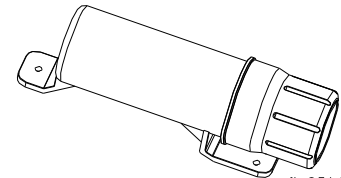

Manual Tube

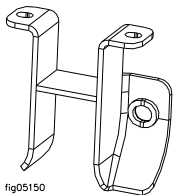

Horizontal Latch
Bracket

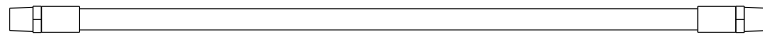

Valve to Cylinder Hose
Part# 778619
High Pressure Hose, 25" x 1/2" ID with
1/2" Male NPT fittings
Qty 1

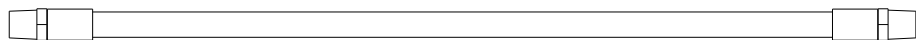

Valve to Hydraulic Pump
Part# 790489
High Pressure Hose, 56" x 1/2" ID with
1/2" Male NPT fittings
Qty 1

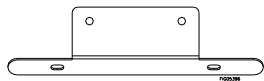

**License Place Mount
Bracket**

Qty 1

(Only used if a license
plate is required)



Valve to Return Line Filter Hose
Part# 790486
Return Line Hose, 69" x 1-1/4" ID
Qty 1

Assembly Instructions

Step 1a – Wiring Harness Installation

- Insert wiring harness end, opposite of plug, through tongue of tow bar. Attach plug end of wiring harness to tongue of tow bar, using wire clip, to hold in place.
- Pull wiring harness out the opposite end of tow bar through which it was inserted.

Tools Needed

Component Needed from Owner's Manual Bag:

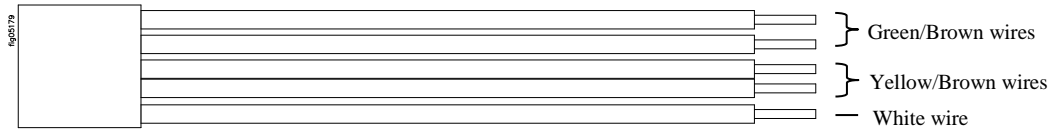

Wiring Harness with Hardware
Qty 1

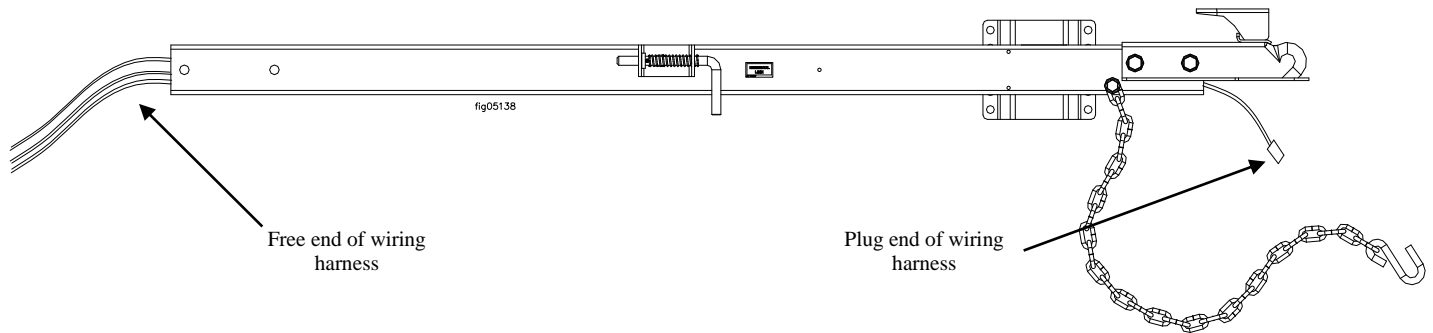

Assembly Instructions

Step 1b – Wiring Harness Installation

- Set hydraulic tank assembly on level surface.
 - Route free end of wiring harness through tow bar mount on tank.
 - Route yellow/brown wires through the “driver’s side” hole of the tow bar mount.
 - Route green/brown wires through the “passenger’s side” hole of the tow bar mount.
 - Insert tow bar into tow bar mount on tank.
- NOTE: White ground wire will be connected in future step.

Tools Needed

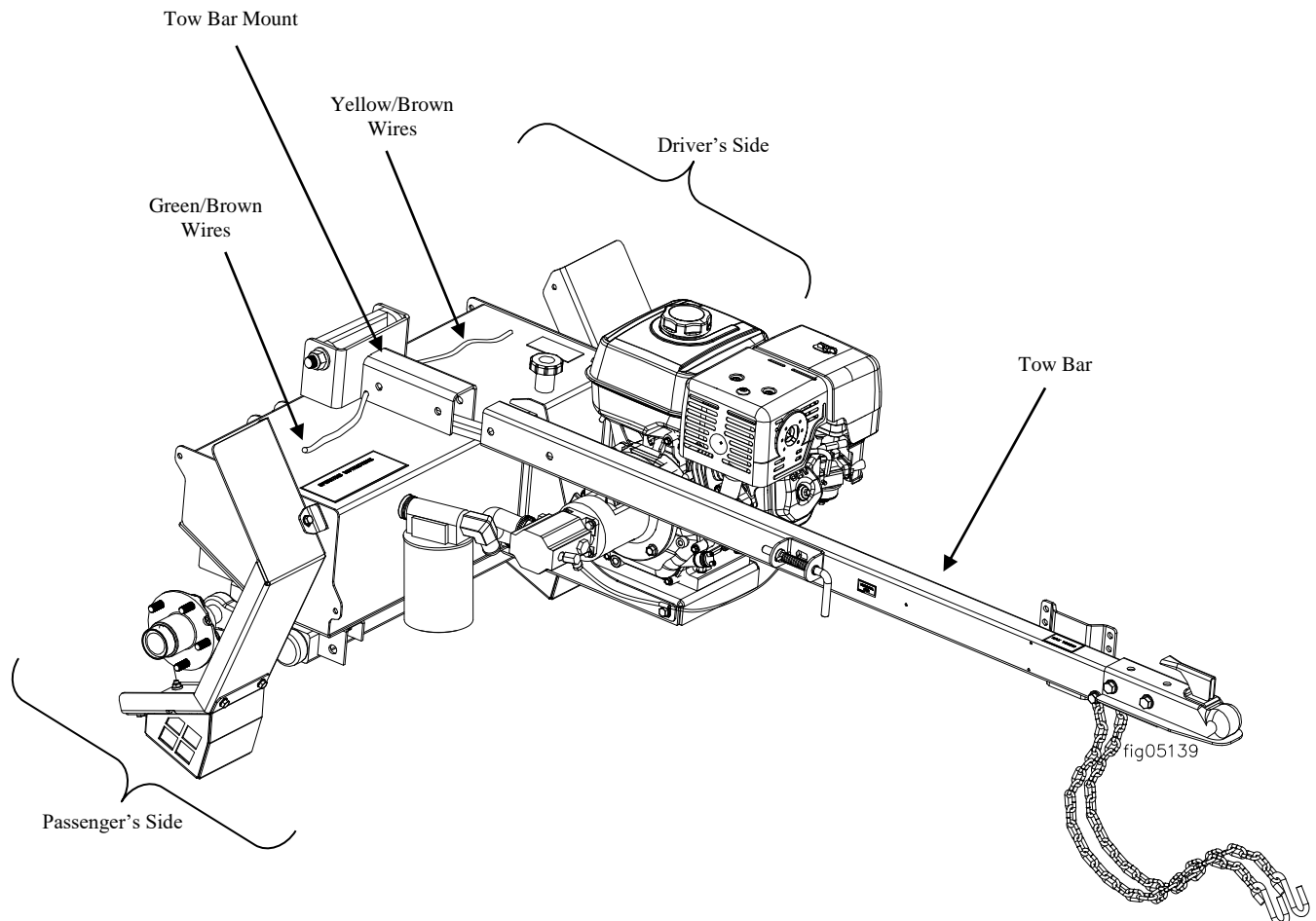

Assembly Instructions

Step 2 – Tow Bar to Tank Assembly

- Align holes on the tow bar to the tow bar mount on the hydraulic tank assembly.
- Install (2) bolts and (2) nuts and tighten with wrench.
- Torque to 71 ft.-lb.
- Insert self-drilling screw into hole in tank tow bar bracket and tighten with impact wrench.

Tools Needed

- 18mm Wrench (2 Needed)
- Torque Wrench
- Impact Wrench

Fasteners Needed from Parts Bag:

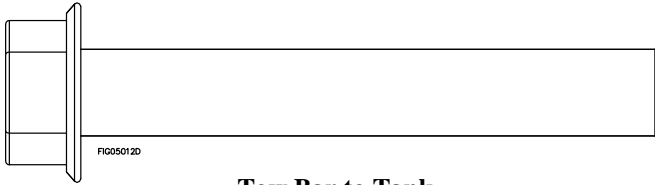

**Tow Bar to Tank
Flange Bolt**
Qty 2

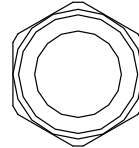

**Tow Bar to Tank
Nylon Insert Locknut**
Qty 2

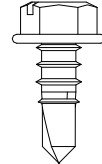

**Tow Bar to Tank
Self-Drilling Screw**
Qty 1

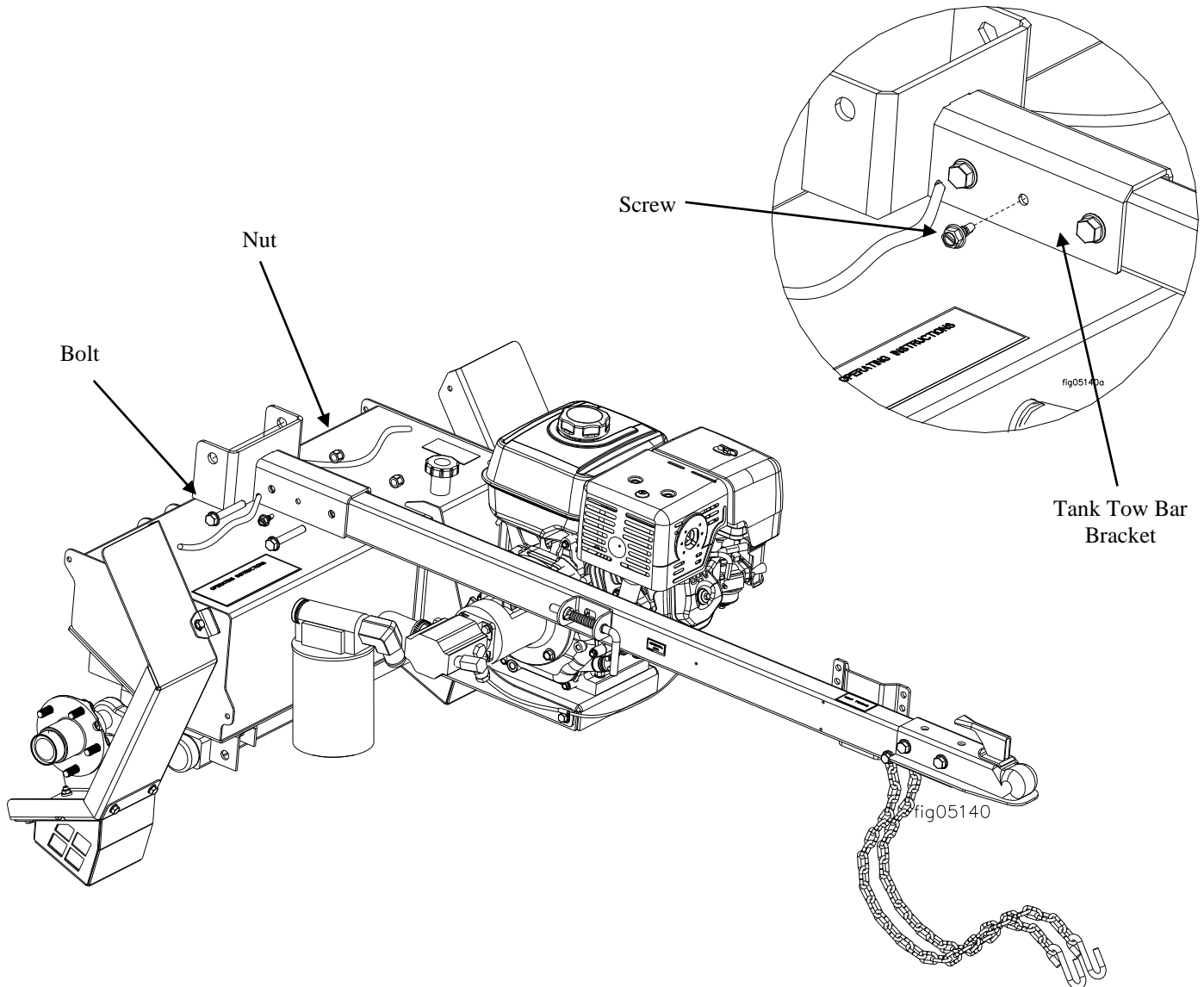

Assembly Instructions

Step 3 – Fender to Tank Assembly

- Slide green/brown wires through black plastic loom. Repeat for yellow/brown wires. Refer to Steps 1a and 1b for wire colors.
- Insert one end of black plastic loom into hole in tow bar mount.
- Detach left and right fenders from hydraulic tank assembly. Discard (2) washers. Retain (2) bolts and (2) nuts that will be reused to attach fenders to tank. NOTE: Left and right fenders will be installed on the opposite sides as delivered in packaging.
- Route each set of wires and black plastic loom through hole in fender.
- Attach fenders to tank using (4) new bolts and (2) existing bolts and (4) new nuts and (2) existing nuts.
- Torque to 21 ft.-lb.
- If a license plate is needed, install license plate mount bracket on left fender using light housing bottom mount bolts and nuts

Tools Needed

- 13mm Wrench
- Torque Wrench

Components Needed from Parts Bag & Owner's Manual Bag:



**Fender to Tank
Flange Nut**
Qty 4

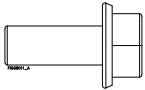

**Fender to Tank
Flange Bolt**
Qty 4

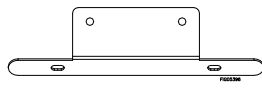

**License Place
Mount Bracket**
Qty 1

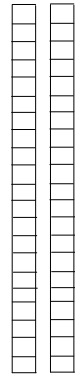

Black Plastic Loom
Qty 2

Black plastic loom
into hole

Black plastic loom
into hole

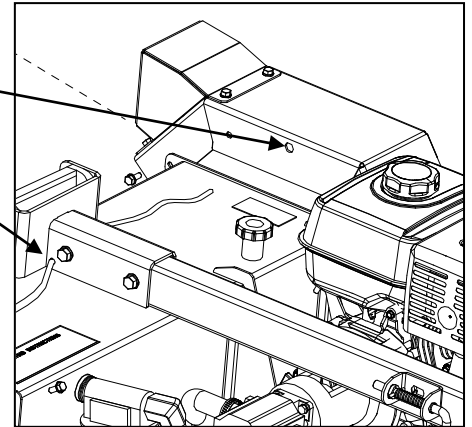

Light housing
bottom mount
bolts and nuts

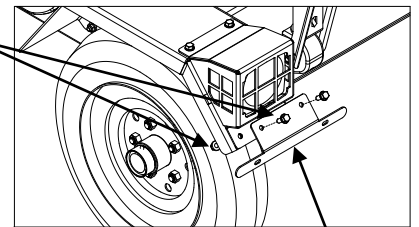

License plate
mount
792411

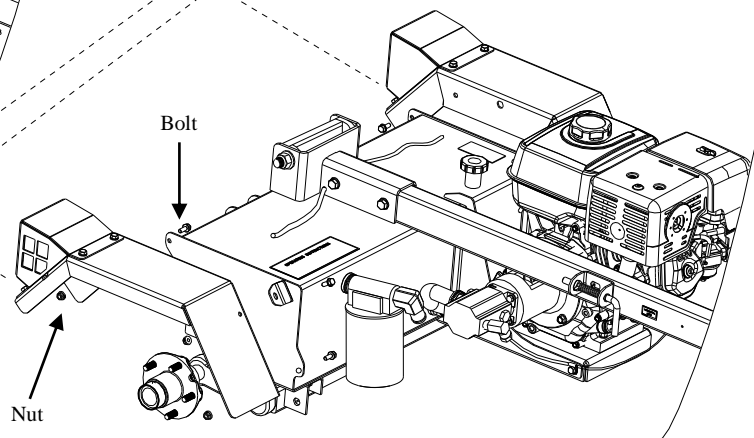
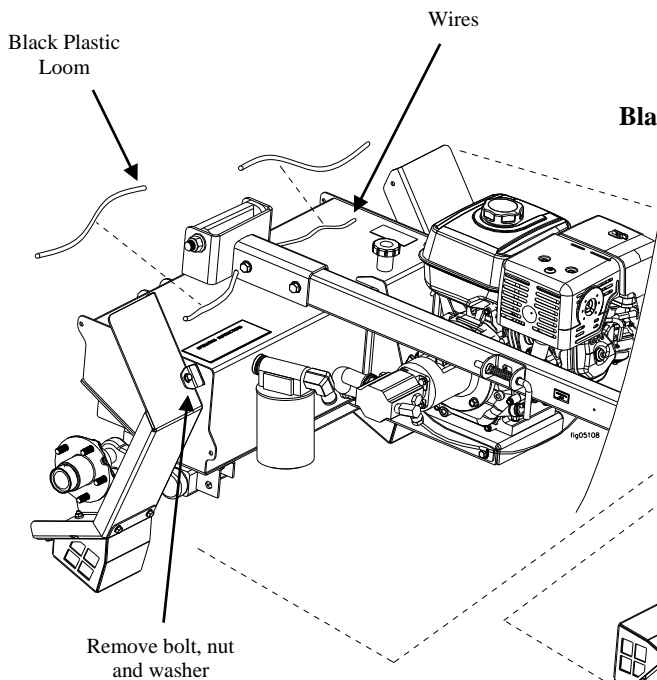

Assembly Instructions

Step 4 – Wiring Lights

- Route wiring harness & through guide tube & hole in fender.
- Connect green wire from wiring harness to green wire from “passenger’s side” lamp and secure with gray wire nut. Repeat for brown wire.
- Connect yellow wire from wiring harness to yellow wire from “driver’s side” lamp and secure with gray wire nut. Repeat for brown wire.
- Ensure wires do not hang down or drag.

Tools Needed

Components Needed from Owner’s Manual Bag:

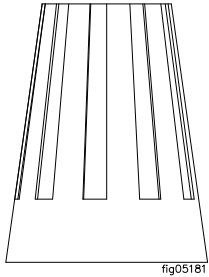

Wiring Harness to Lights

Wire Nut
Qty 4

Guide Tube
Guide hole

Wiring Harness

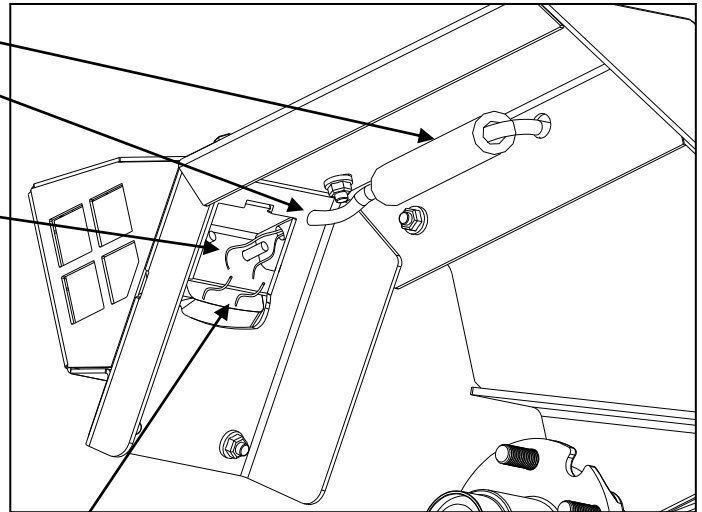

Side Lamp Wires

Black plastic loom

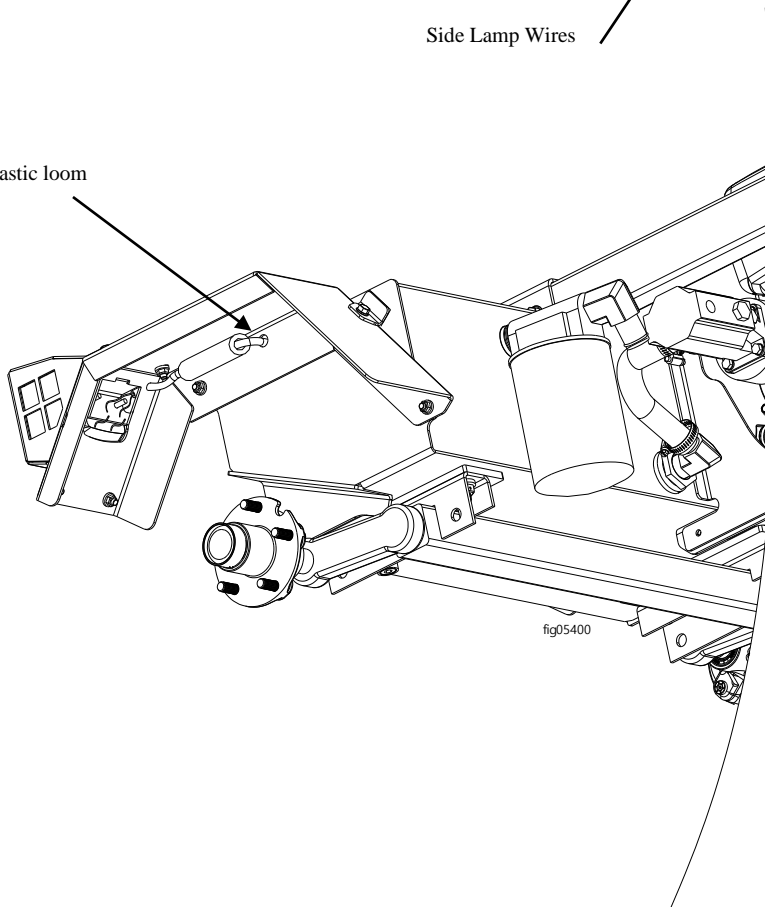

Assembly Instructions

Step 5 – Tire to Tank Assembly

NOTE: Hex nuts are installed on axle. Remove first before installing tire.

- Slide tire onto axle with valve stem facing out.
- Thread nuts onto axle until hand tight. Tighten the lug nuts in stages. Follow the sequence listed:

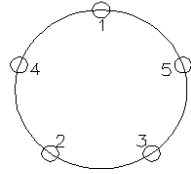

5 Bolt Hub

- Torque nuts to: 1st Stage: 20-25 ft.-lbs., 2nd Stage: 35-40 ft.-lbs., 3rd Stage: *60-75 ft.-lbs. * Verify final torque based on wheel type and wheel manufacture recommendations.

Tools Needed

- Pliers
- Crescent Wrench
- 3/4" Socket & Ratchet
- Torque Wrench

Fasteners Needed (installed on axle):

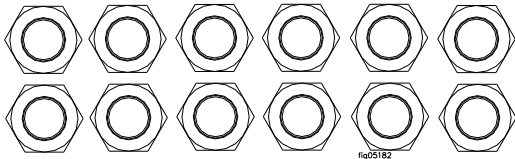

Wheel to Axle
Hex Nut
Qty 10

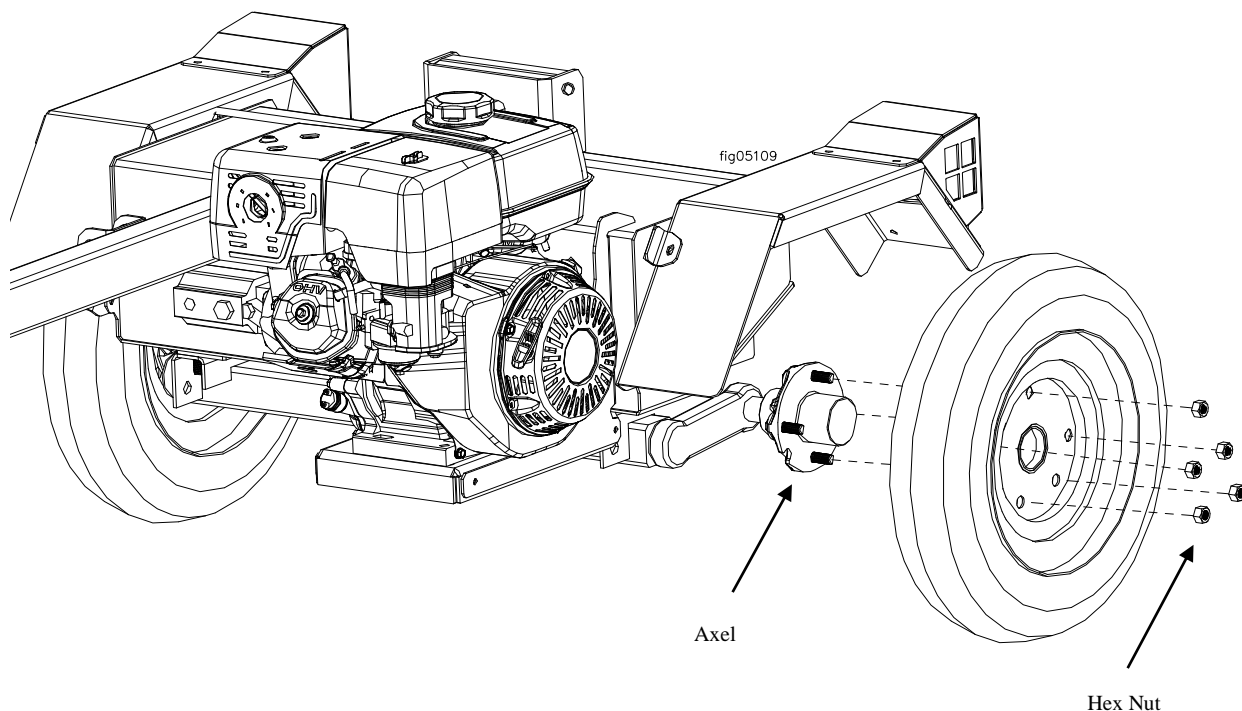

Assembly Instructions

Step 7 – Jack to Jack Mount/Tow Bar

- Connect jack to jack mount located on the front end of the tow bar.
- Align jack bracket to jack mount on tow bar. Insert (4) bolts and thread on (4) locknuts.
- Torque to 41 ft.-lb.

Tools Needed

- 15mm Wrench
- 16mm Wrench
- Torque Wrench

Fasteners Needed from Parts Bag:

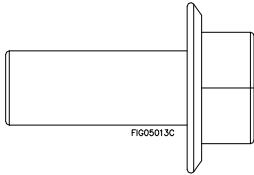

**Jack to Tow Bar
Flange Bolt
Qty 4**

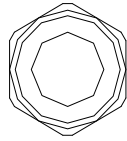

**Jack to Tow Bar Nylon
Nyloc Nut
Qty 4**

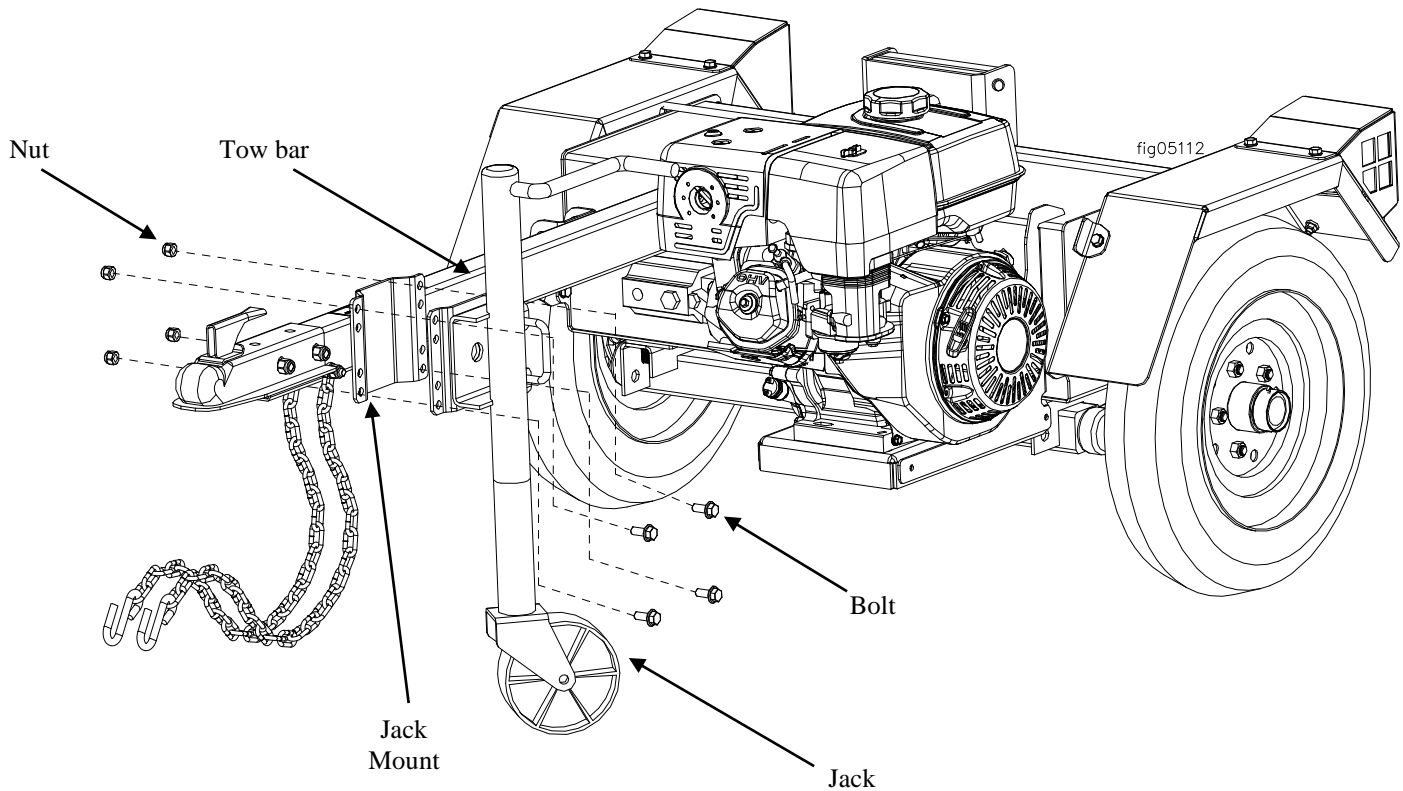

Assembly Instructions

Step 8 – Outrigger Leg to Tank

- Connect the rear outrigger leg to the backside of the hydraulic tank assembly
- Tighten nut until snug then back off 1/2 turn
- NOTE: Once the Outrigger Leg is installed, lock the leg in the down position using the Outrigger Leg Lock.

Tools Needed

- 15mm Wrench
- 16mm Wrench

Fasteners Needed from Parts Bag:

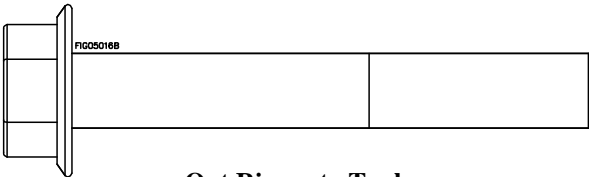

Out Rigger to Tank
Flange Bolt
Qty 1

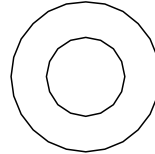

Out Rigger to Tank
Washer
Qty 1

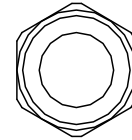

Out Rigger to Tank
Nyloc Nut
Qty 1

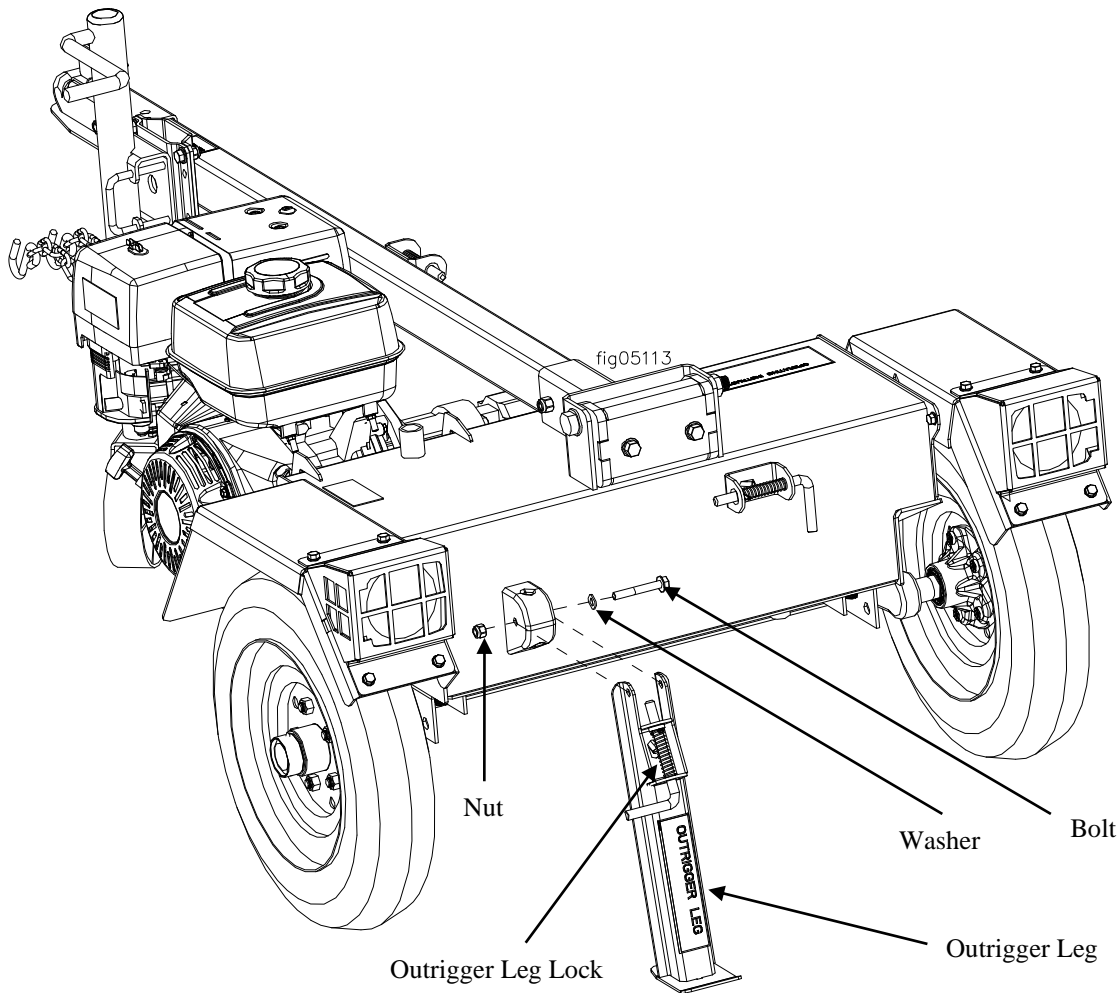

Assembly Instructions

Step 9 – Install Manual Tube/ White Ground Wire

- Remove the manual tube cover from manual tube
- Align holes in manual tube with holes in tow bar
- Insert (1) Self-Tapping Screw through eyelet of white ground wire and through manual tube hole into tow bar. Use the remaining (2) screws to secure the manual tube to tow bar
- Reattach the manual tube cover onto the manual tube
- Insert white wire from wiring harness into butt connector of white ground wire.
- Crimp butt connector to secure wires.

Tools Needed

- 11mm Socket Wrench
- Pliers

Fasteners Needed from Parts Bag:

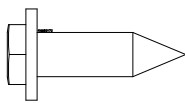

Manual Tube
Self Tapping Screw
Qty 3

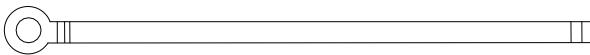

White Ground Wire
Qty 1

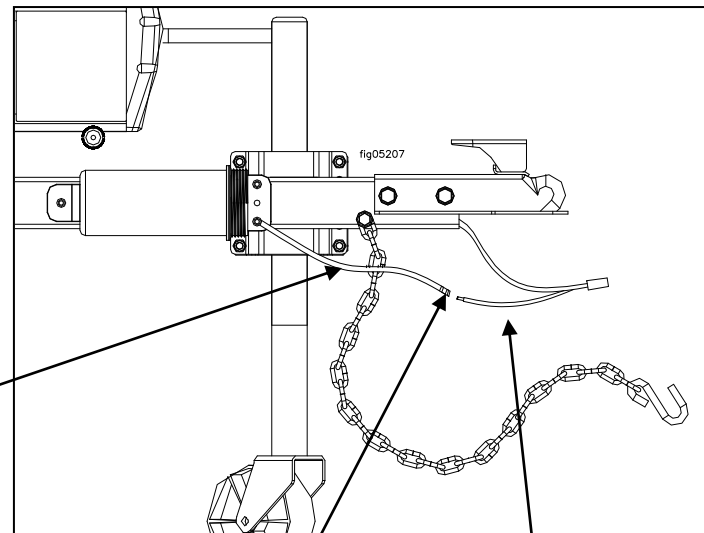

White ground wire

Butt connector

White wire on wiring harness

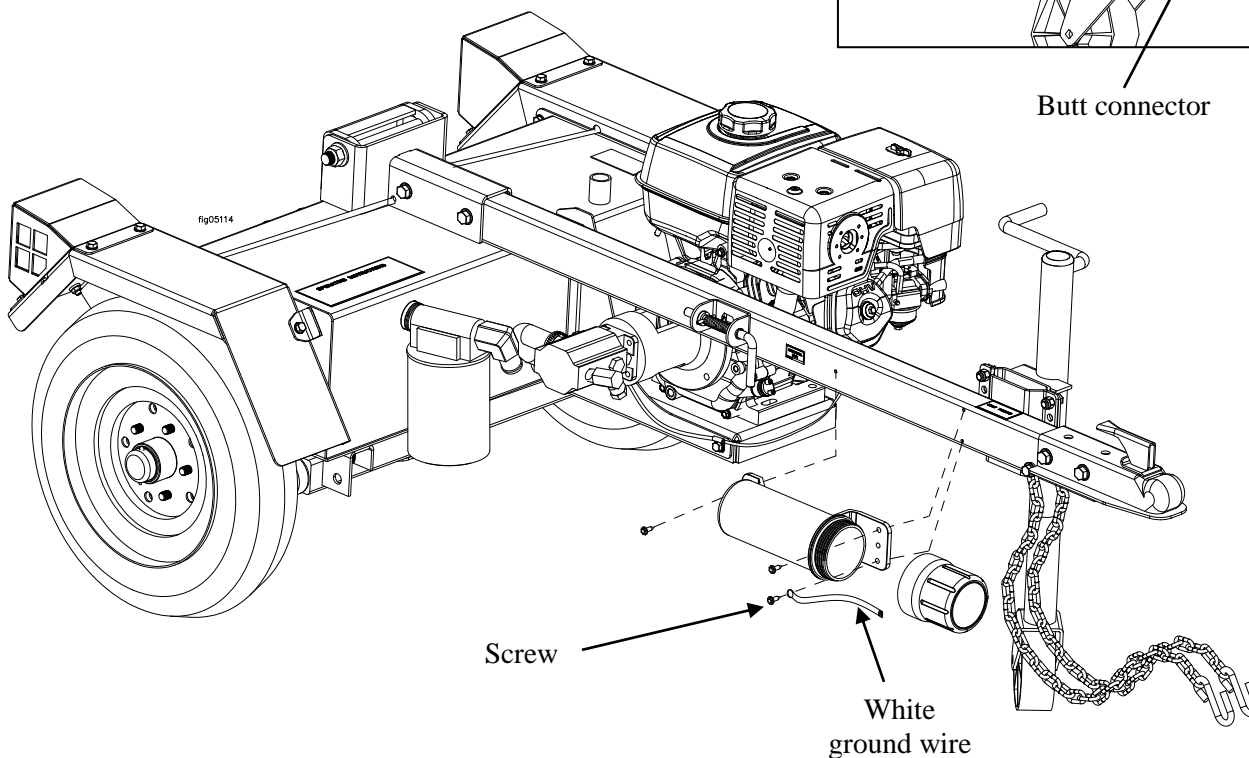

Screw

White ground wire

Assembly Instructions

Step 10a – Install Beam Assembly

- Push pivot bracket so that it is parallel to the back side of tank.
- Stand beam assembly on end plate with the help of another person. Have that person hold the beam in place while maneuvering the log splitter as shown.

Tools Needed

- 18mm Wrench
(2 Needed)

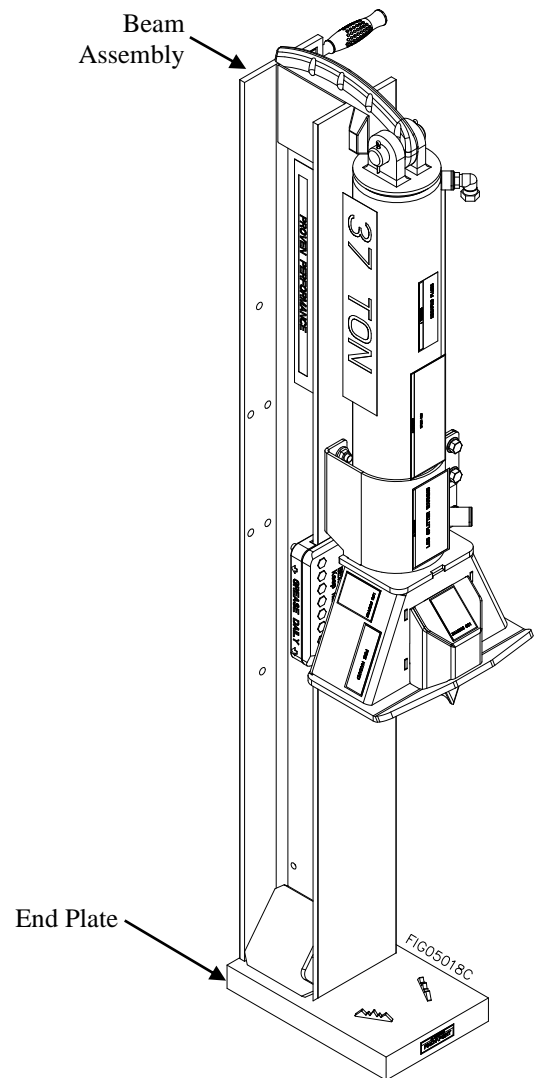
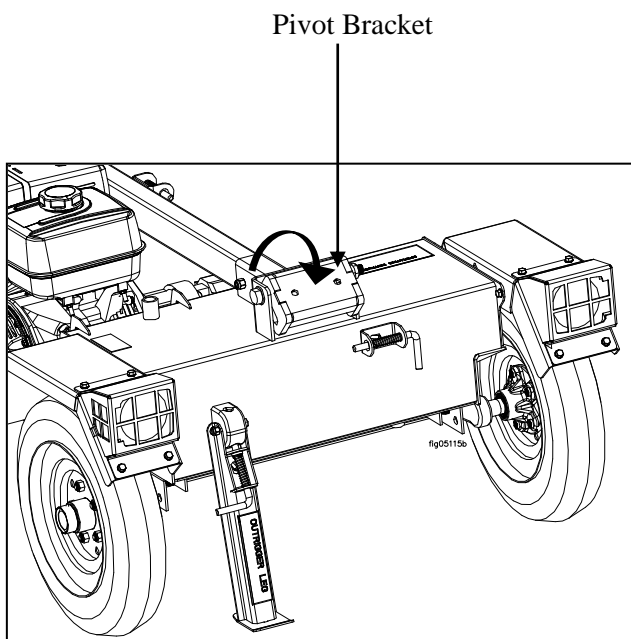

Assembly Instructions

Step 10b – Install Beam Assembly Cont'd

- Maneuver log splitter and align with the beam as shown below.
NOTE: Once log splitter is in line with beam, put the outrigger leg in the **DOWN** position to stabilize splitter for assembling.
- Insert (2) bolts and thread (2) nuts onto bolts.
- Torque to 71 ft.-lb.

Tools Needed

- 18mm Wrench (2 Needed)
- Torque Wrench

Fasteners Needed from Parts Bag:

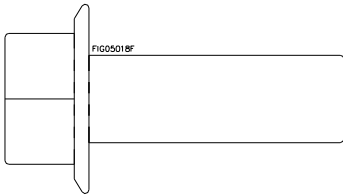

Beam to Pivot Bracket
Flange Bolt
Qty 2

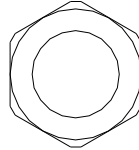

Beam to Pivot Bracket
Nyloc Nut
Qty 2

Completed View

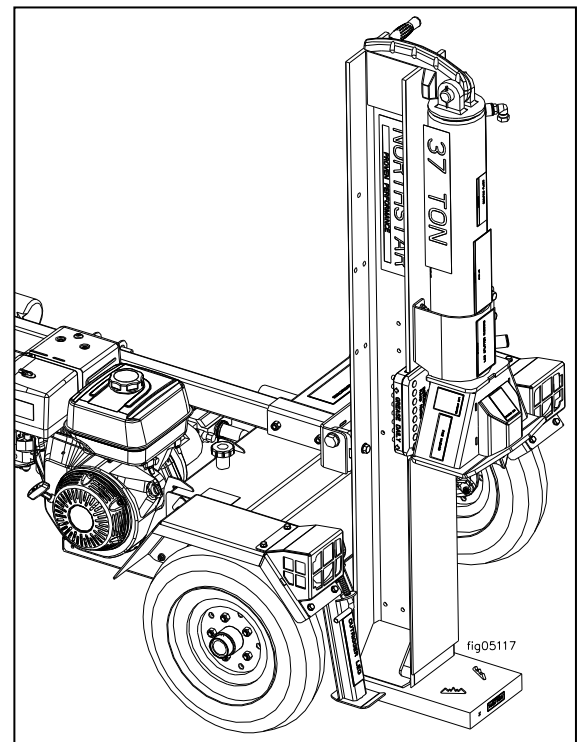
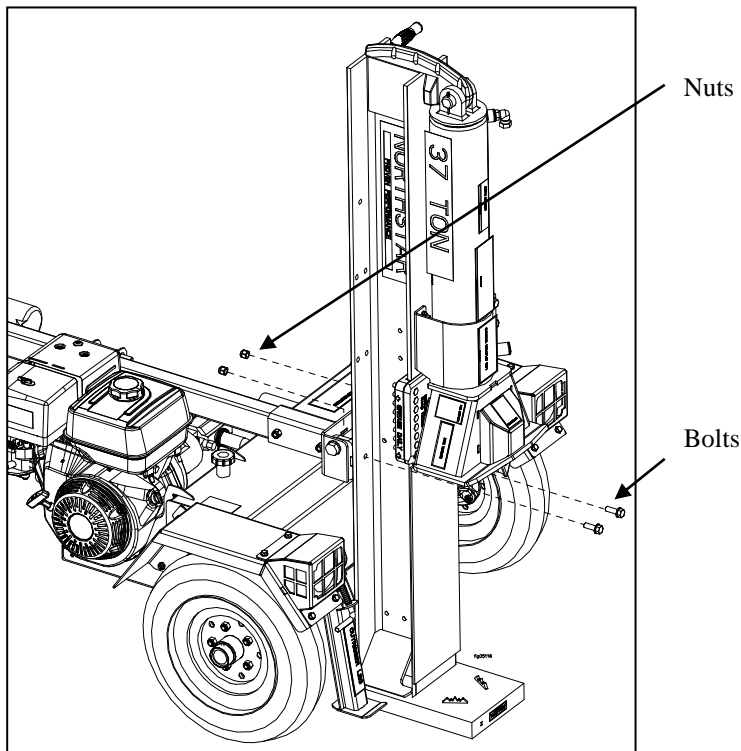

Assembly Instructions

Step 11 – Horizontal Latch to Beam

- Align horizontal latch to beam using (2) bolts and (2) nuts.
- Torque to 71 ft.-lb.
- Ensure that the Outrigger leg is in the DOWN position.
- Using the handle on the beam, lower beam to the tow bar. Pull horizontal lock latch rod outwards to allow the beam to rest properly on the tow bar. Push latch rod forward to lock in the horizontal position.
- See page 20 for further instruction.

Tools Needed

- 18mm Wrench
- Torque Wrench

Fasteners Needed from Parts Bag:

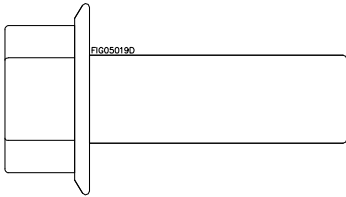

Horizontal Latch to Beam
Flange Bolt
Qty 2

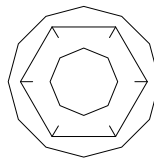

Horizontal Latch to Beam
Flange Nut
Qty 2

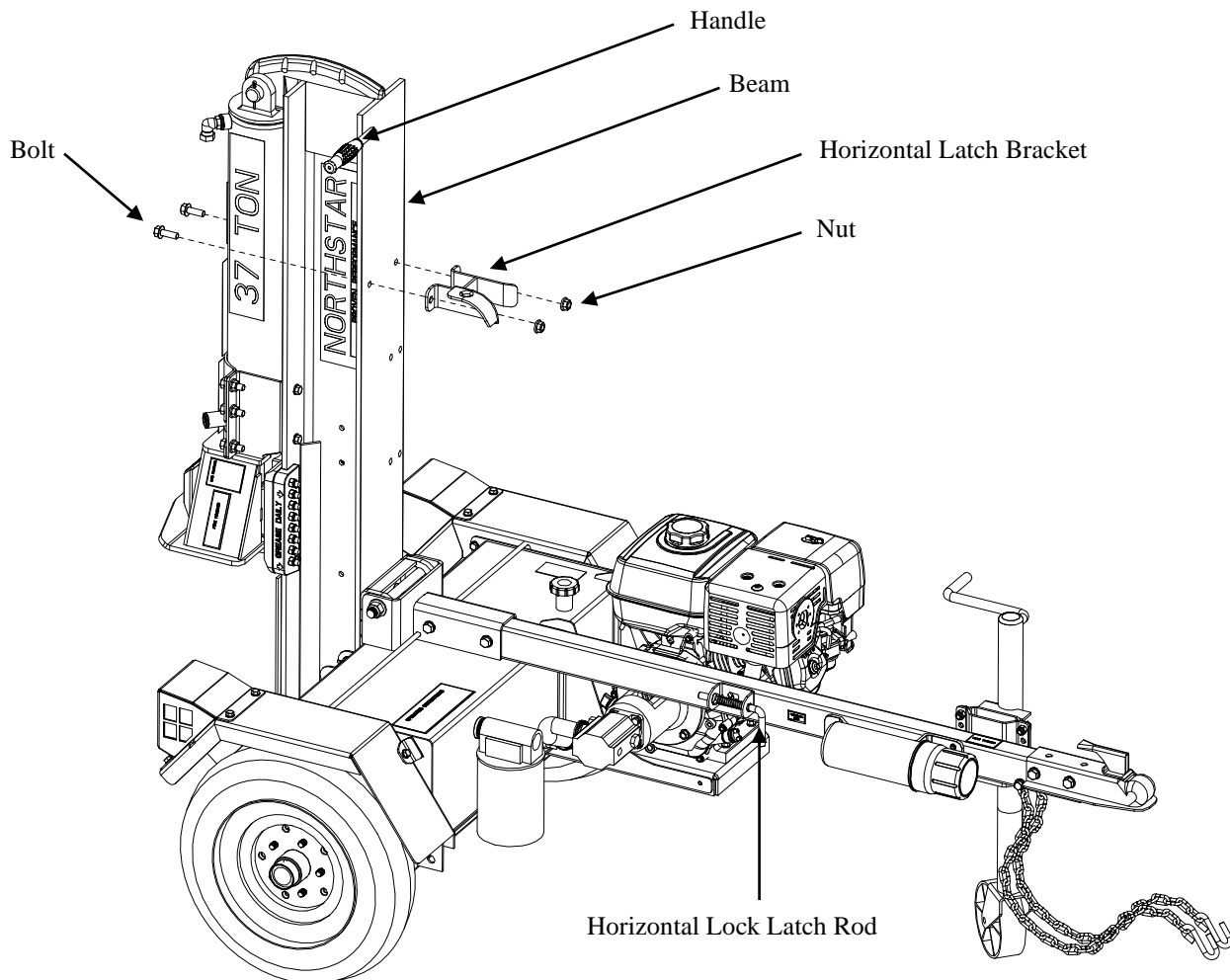

Assembly Instructions

Step 12 – Log Tables to Beam

- Align right side log table to beam and insert the top (2) bolts and bottom (2) bolts.
 - Align left side log table to the bolts inserted above. Add (4) nuts onto bolts and secure tightly.
 - Torque to 21 ft.-lb.
- NOTE: It may be helpful to have another person assist with this step.

Tools Needed

- 13mm Wrench
- Torque Wrench

Fasteners Needed from Parts Bag:

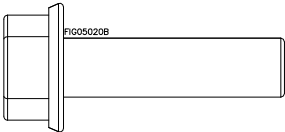

Log Cradle to Beam
Flange Bolt
Qty 4

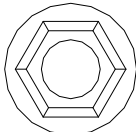

Log Cradle to Beam
Flange Nut
Qty 4

Side view of installed bolts

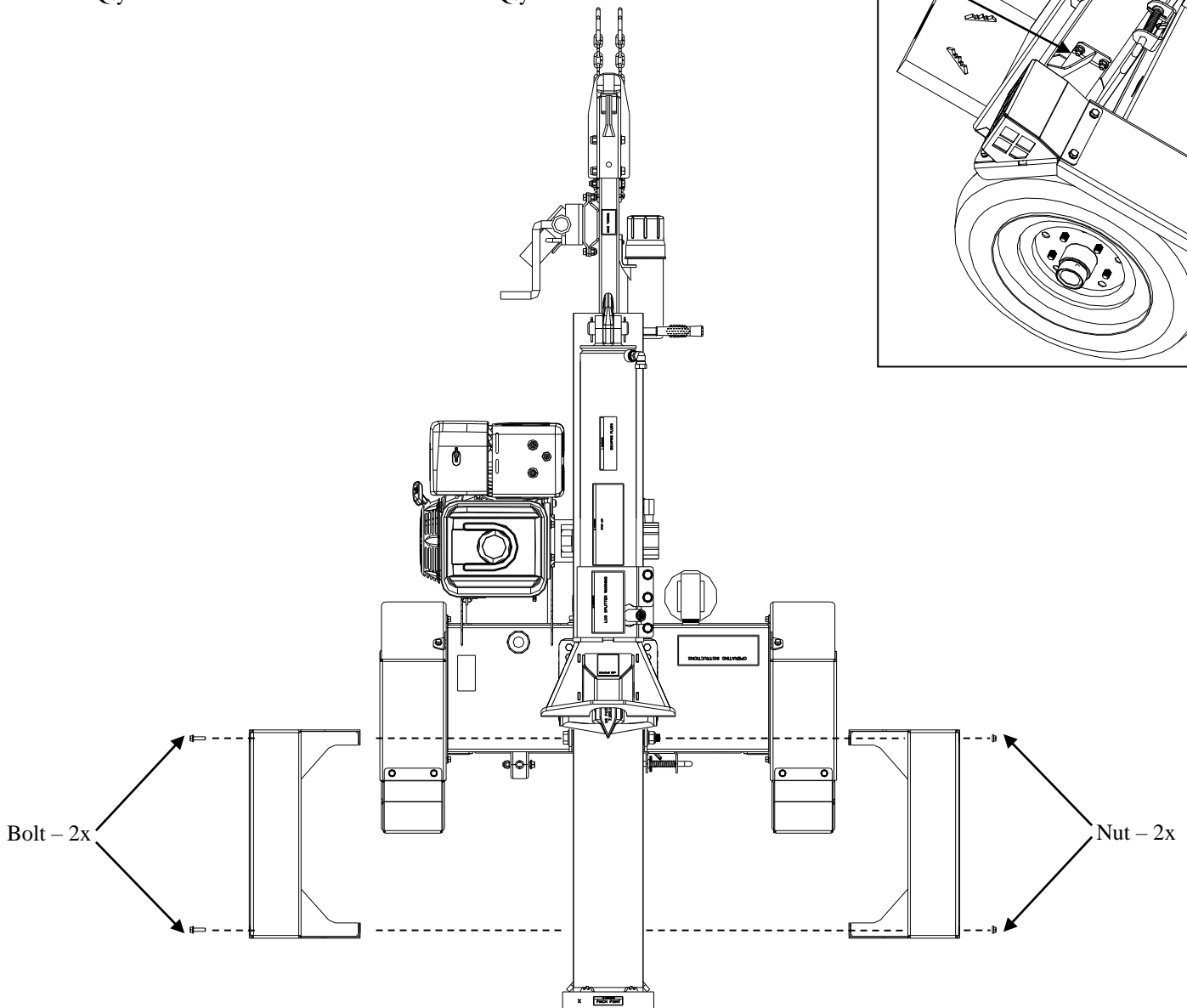
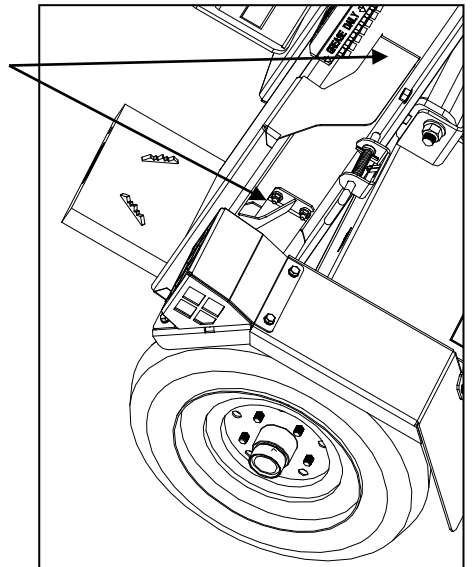

Assembly Instructions

Step 13 – Throttle Bracket Setup

- Attach throttle bracket assembly to beam using (2) Throttle Cable to Beam Flange Bolts and (2) Throttle Cable to Beam Flange Nut.
 - Align bolts in center of slots on throttle bracket. Torque to 21 ft.-lb.
- NOTE: Adjust throttle bracket forward or backward for optimal engine performance.

Tools Needed

- 13mm Wrench
- Torque Wrench

Fasteners Needed from Parts Bag:

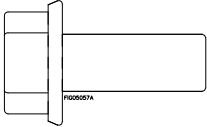

**Throttle Cable to Beam
Flange Bolt**
Qty 2

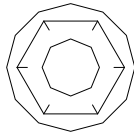

**Throttle Cable to Beam
Flange Nut**
Qty 2

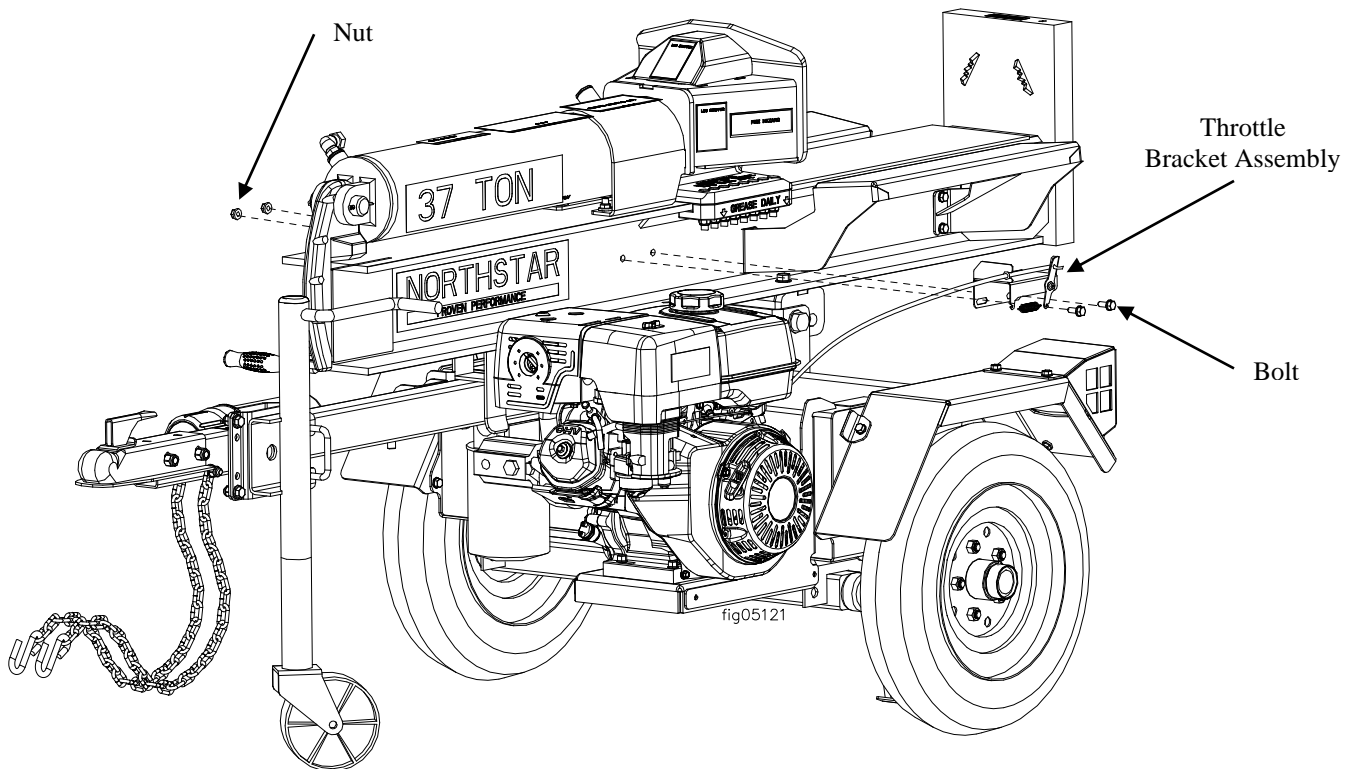

Assembly Instructions

Step 14 – Engine Guard to Beam

NOTE: Assemble the engine guard to the beam in the horizontal position

- Align engine guard to the two sets of holes in the beam
- Slide the vinyl coated clamp located on throttle cable to the hole on the engine guard shown below. See next page for correct clamp location.
- Using (4) bolts, (4) nuts and (3) washers, secure engine guard to beam. Secure vinyl coated loop clamp from previous step to underside of beam as shown. Do not use a washer on the bolt used to secure the cable clamp.
- Torque to 20 ft.lb. CAUTION: Over-tightening can crush tube.

Tools Needed

- 13mm Wrench (2 Needed)
- Torque Wrench

Fasteners Needed from Parts Bag:

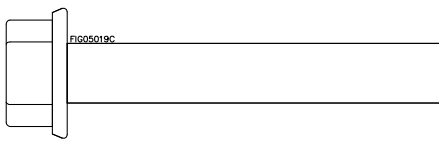

Engine Guard to Beam Long
Flange Bolt
Qty 2

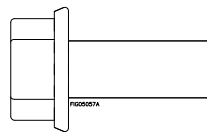

Engine Guard to Beam Short
Flange Bolt
Qty 2



Engine Guard to Beam
Nyloc Nut
Qty 4

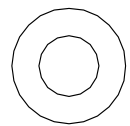

Engine Guard to Beam
Washer
Qty 3

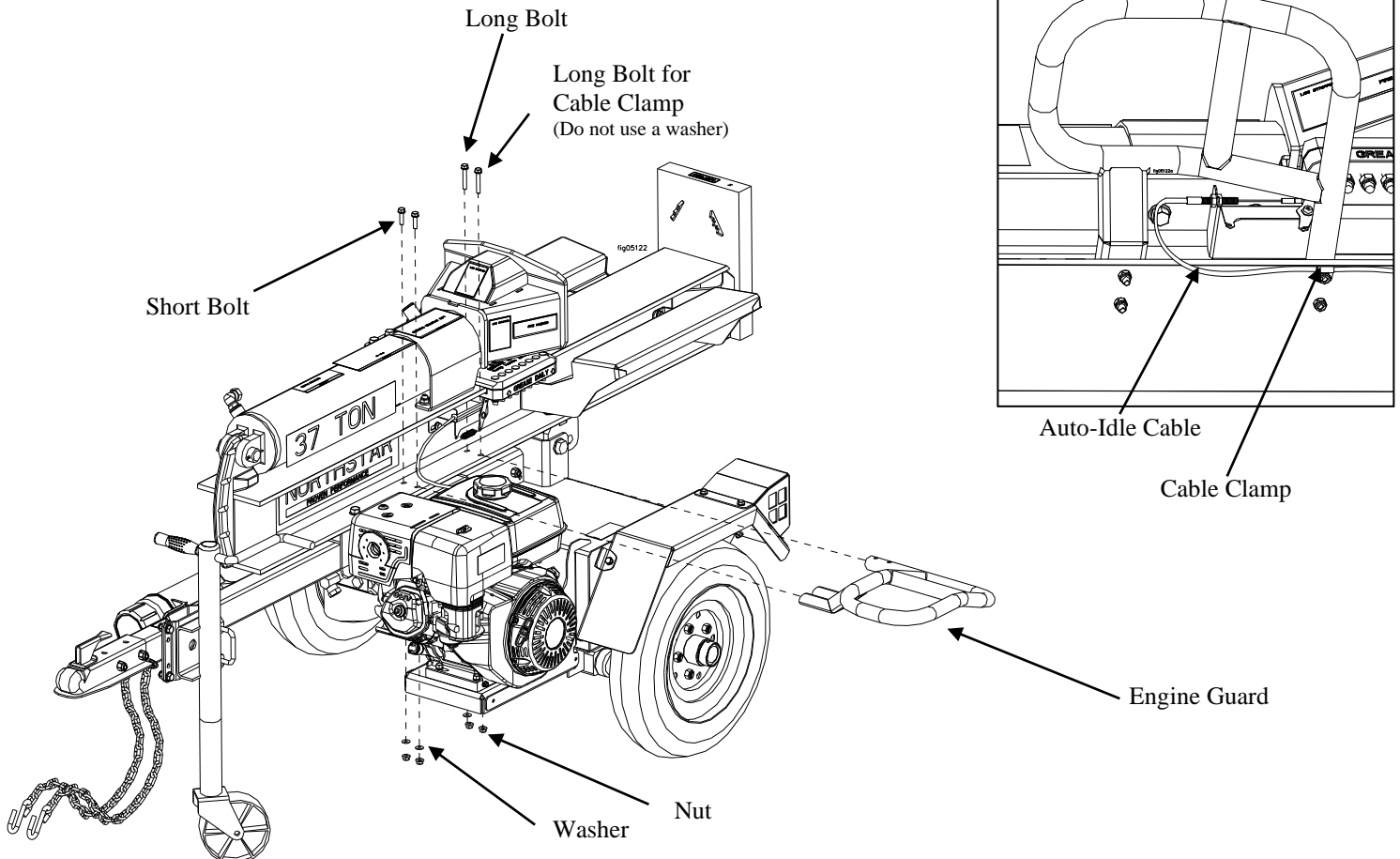

Assembly Instructions

Step 14 – Engine Guard to Beam Cont.

- Position vinyl coated loop clamp so that throttle cable routing is similar to what is depicted below. NOTE: Distance from throttle bracket assembly to end of throttle cable should be at least 2.5”.

Tools Needed

- 13mm Wrench
(2 Needed)

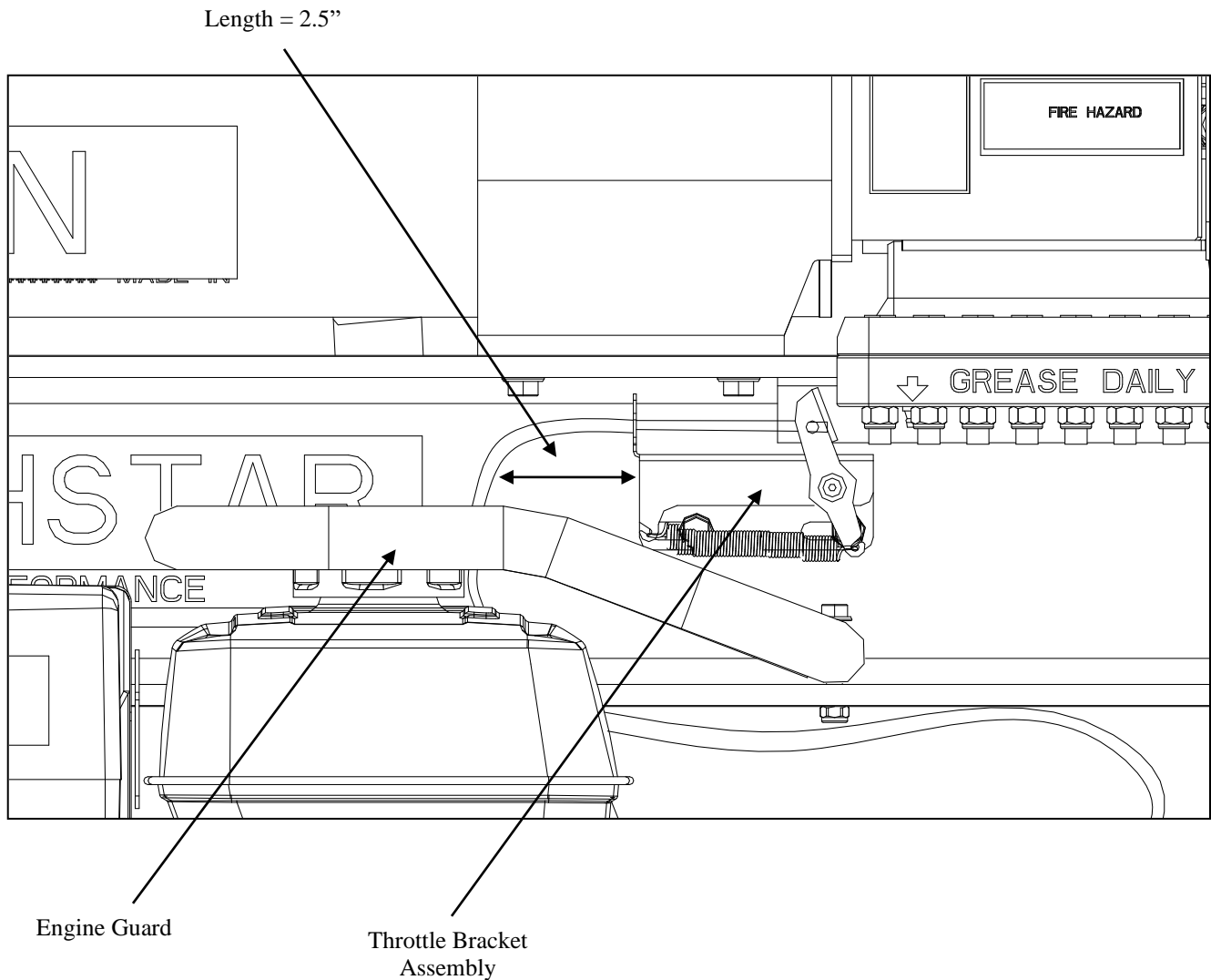

Assembly Instructions

Step 15 – Control Valve

- Slide control valve handle into the clevis slots on the control valve.
- Align holes in handle with clevis holes.
- Insert the supplied pins through holes and secure with supplied bridge clips.

Tools Needed

- Pliers

Parts Needed from Log Splitter Box:

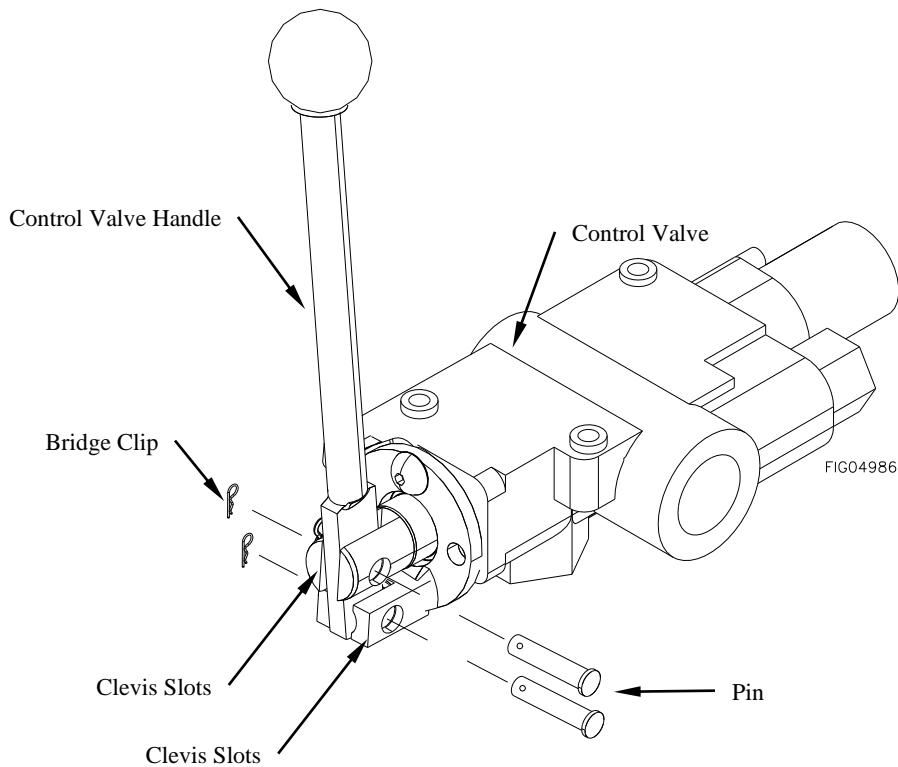
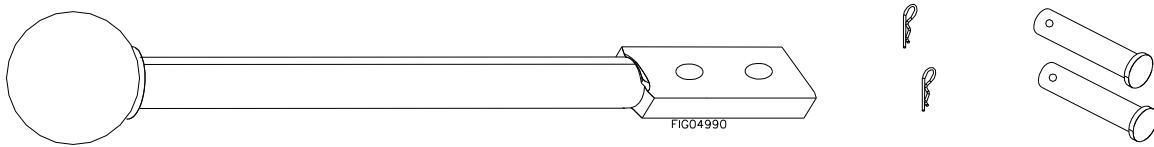

Assembly Instructions

Step 16 – Valve Installation

- Remove plug from cylinder port and discard
- Lubricate O-ring and threads on Valve Fitting with clean oil
- Orientate (1) Valve Fitting so that nut/washer/O-ring assembly is facing up. Turn fitting into cylinder port until finger-tight
- Torque to 27-43 ft.-lb.
- Looking at fitting from end with nut/washer/O-ring assembly, turn nut clockwise as far as possible
- Use valve port marked “A” to thread the control valve onto the installed Valve Fitting until control valve touches washer
- Hold control valve in orientation shown below and torque nut to 20-30 ft.-lb.

Tools Needed

- 7/8” Wrench
(2 needed)
OR
- Crescent Wrench
(2 needed)
- Torque Wrench

Part Needed from Parts Bag:

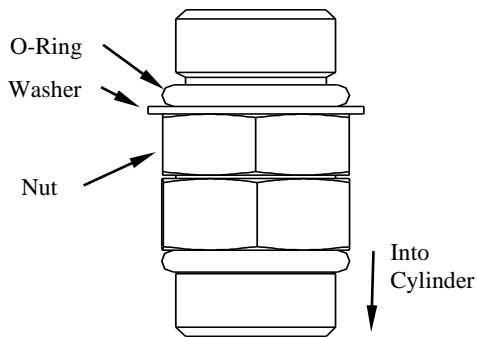

Part # 790488
Valve Fitting
Qty: 1

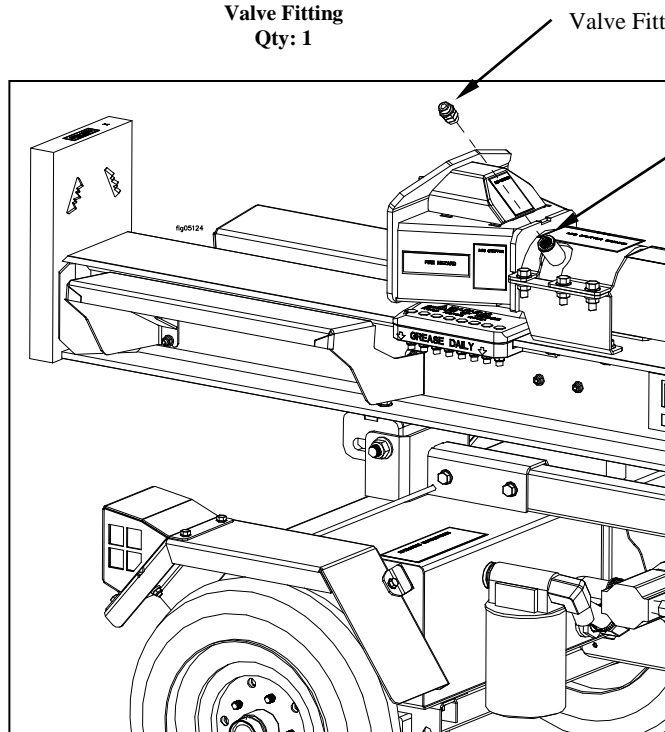

Hydraulic Control
Valve

Cylinder Port

Valve Fitting

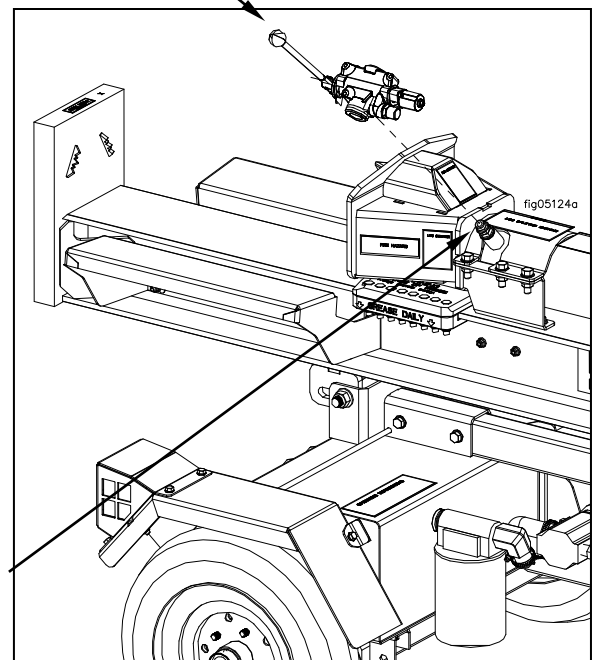

Assembly Instructions

Step 16 – Valve Installation Continued

- Remove plugs from ports in control valve
- Lubricate O-ring and threads on fitting with clean oil
- Looking at fitting from end with nut/washer/O-ring assembly, turn nut clockwise as far as possible
- Using wrench, turn (1) Valve to Hydraulic Pump Fitting into valve port marked “B” until washer touches control valve. Continue turning until washer touches thread nearest wrench pad
- Back off fitting counterclockwise not exceeding one revolution until it is oriented in the correct position
- Place wrench on the wrench pad of fitting to prevent fitting from turning and torque nut to 20-30 ft.-lb.

Tools Needed

- 1-1/16” Wrench
- 1-1/4” Wrench
- OR
- Crescent Wrench (2 needed)
- Torque Wrench

Part Needed from Parts Bag:

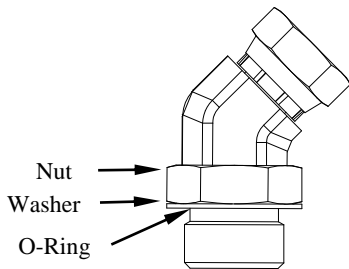

Valve to Hydraulic Pump Fitting
Part# 791219
Qty 1

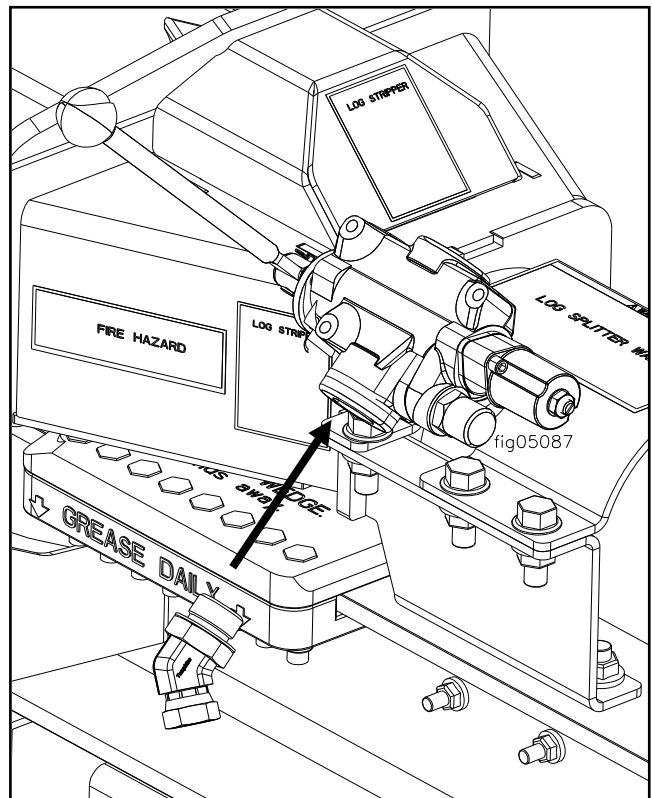
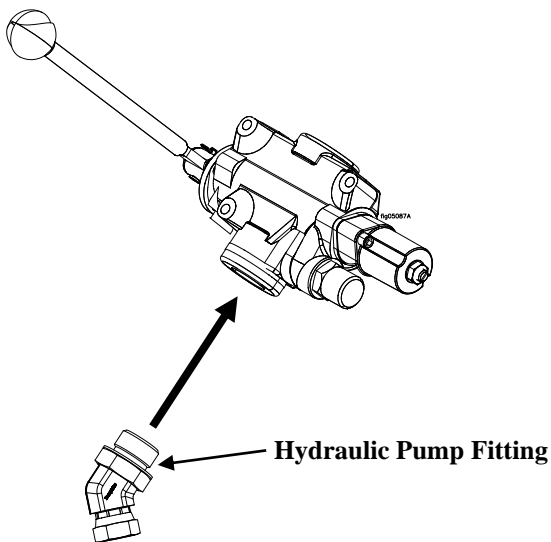
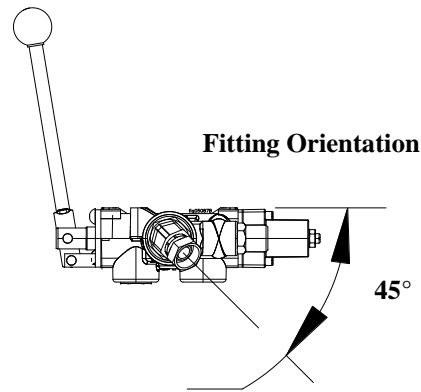

Assembly Instructions

Step 16 – Valve Installation Continued

- Remove plugs from ports in control valve
- Lubricate O-ring and threads on fitting with clean oil
- Looking at fitting from end with nut/washer/O-ring assembly, turn nut clockwise as far as possible
- Using wrench, turn (1) Valve to Cylinder Fitting into valve port marked “IN” until washer touches control valve. Continue turning until washer touches thread nearest wrench pad
- Back off fitting counterclockwise not exceeding one revolution until it is oriented in the correct position
- Place wrench on the wrench pad of fitting to prevent fitting from turning and torque nut to 44-55 ft.-lb.

Tools Needed

- 7/8” Wrench
- 3/4” Wrench
OR
- Crescent Wrench
(2 needed)
- Torque Wrench

Part Needed from Parts Bag:

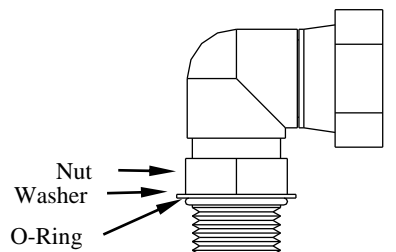

Valve to Cylinder Fitting
Part# 778827
Qty 1

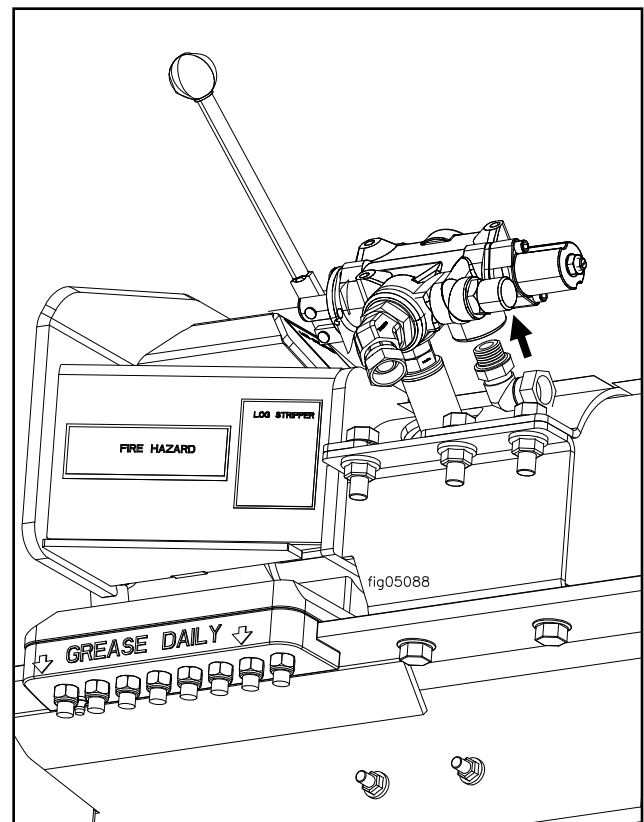
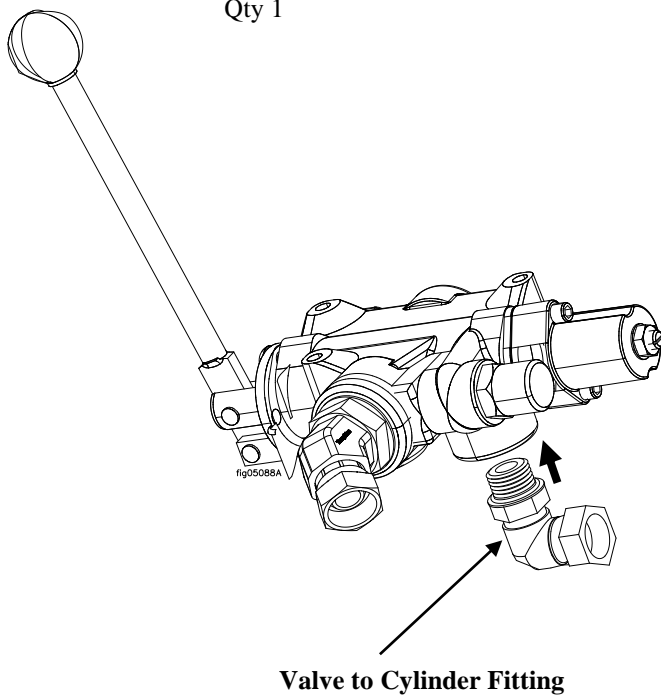

Assembly Instructions

Step 16 – Valve Installation Continued

- Remove plugs from ports in control valve
- Lubricate O-ring and threads on fitting with clean oil
- Looking at fitting from end with nut/washer/O-ring assembly, turn nut clockwise as far as possible
- Using wrench, turn (1) Valve to Hydraulic Filter/Tank Fitting into valve port marked “OUT” until washer touches control valve. Continue turning until washer touches thread nearest wrench pad
- Back off fitting counterclockwise not exceeding one revolution until it is oriented in the correct position
- Place wrench on the wrench pad of fitting to prevent fitting from turning and torque nut to 44-55 ft.-lb.

Tools Needed

- 1-1/16” Wrench
- 1-1/4” Wrench
OR
- Crescent Wrench
(2 needed)
- Torque Wrench

Part Needed from Parts Bag:

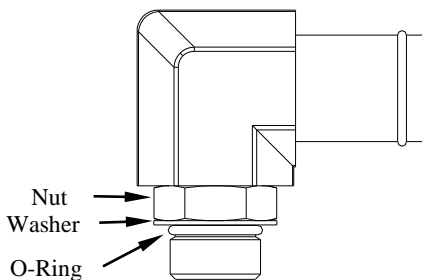

Valve to Hydraulic Filter Fitting
Part# 789051
Qty 1

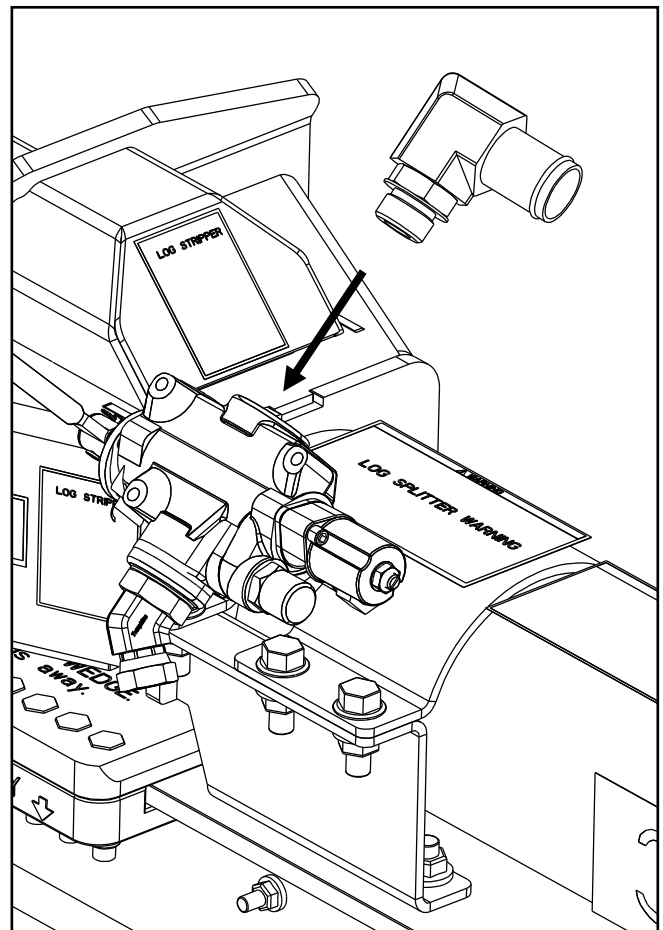
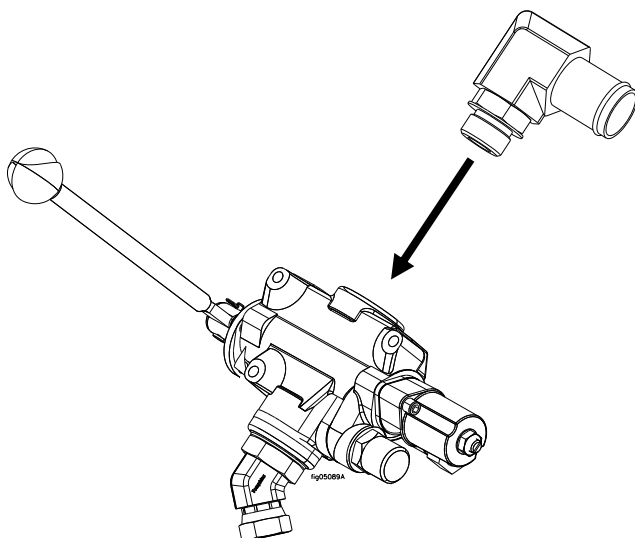

Assembly Instructions

Step 16 – Valve Installation Continued

- Align valve plate to the top three holes on the mounted valve.
- Using (3) screws and (3) nuts secure plate to valve.
- Torque to 102 in.-lb.

Tools Needed

- 10mm Wrench
- Philips Screw Driver
- Torque Wrench

Parts Needed from Parts Bag:

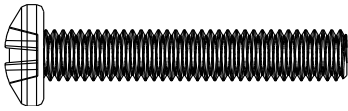

Valve Plate
Cap Screw
Qty 3

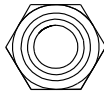

Valve Plate
Nylon Insert Nut
Qty 3

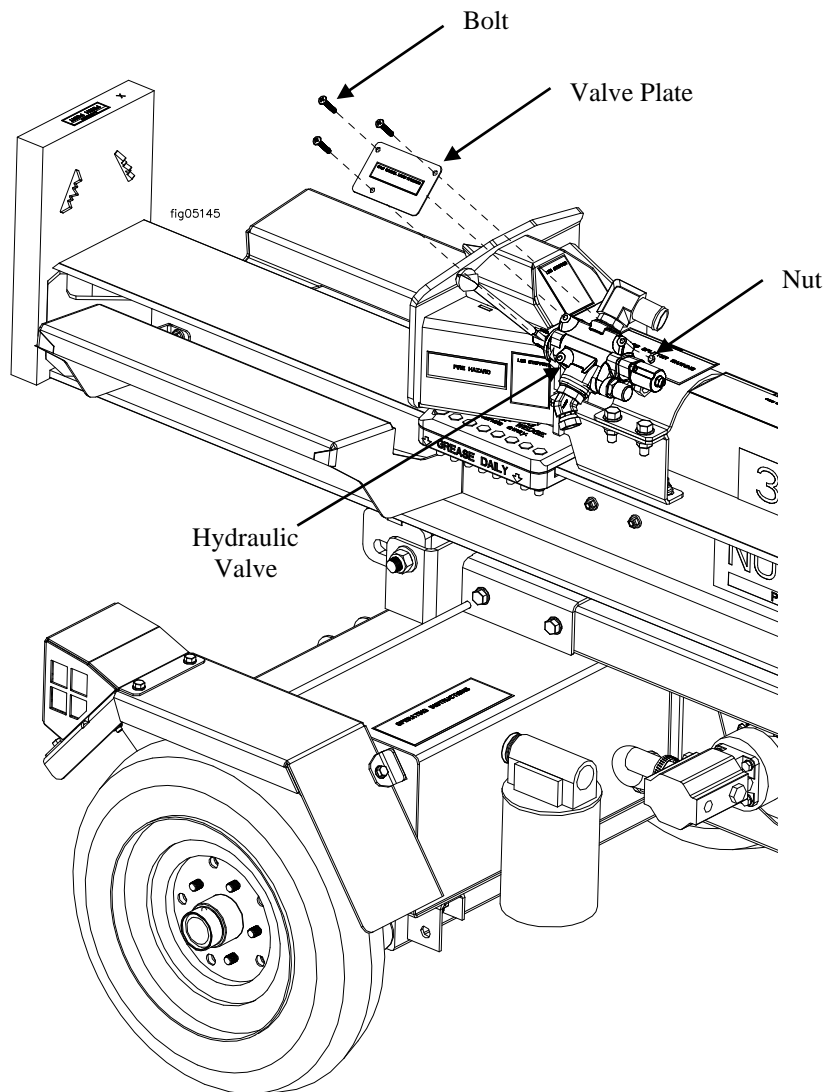

Assembly Instructions

Step 17 – High Pressure Hose Routing

- Route (1) Short High Pressure Hose from the Valve to Cylinder Fitting on the control valve to the 90° elbow cylinder fitting.
- Screw finger-tight Short High Pressure Hose to the Valve to Cylinder Fitting. Use wrench to hold hose secure. Use other wrench to tighten fitting swivel. Tighten 1.5-3.0 Turns Past Finger Tight.
- Screw finger-tight Short High Pressure Hose to the 90° elbow cylinder fitting. Use wrench to hold hose secure. Use other wrench to tighten fitting swivel. Tighten 1.5-3.0 Turns Past Finger Tight.

Tools Needed

- 1" Wrench
- 7/8" Wrench
- OR
- Crescent Wrench (2 Needed)

Part Needed from Log Splitter Box:

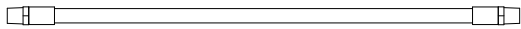

Valve to Cylinder Hose

High Pressure Hose, 21.75" x 1/2" ID with
1/2" Male NPT fittings
Qty 1

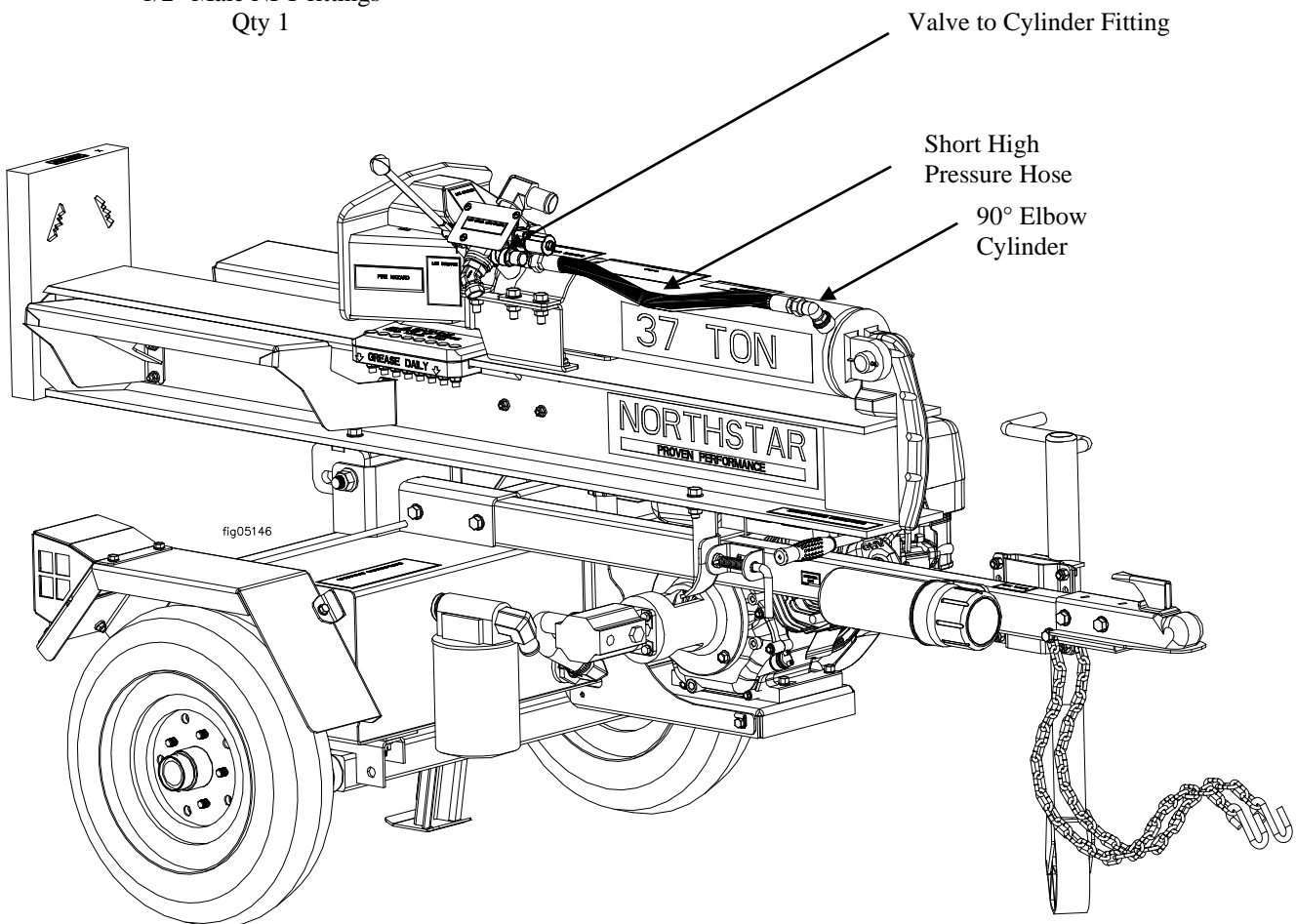

Assembly Instructions

Step 17 – High Pressure Hose Routing Cont'd

- Route (1) Long High Pressure Hose from the Valve to Hydraulic Pump Fitting on the control valve to the 90° elbow fitting on pump as shown below.
- Screw finger-tight Long High Pressure Hose to the Valve to Hydraulic Pump Fitting. Use wrench to hold hose secure. Use other wrench to tighten fitting swivel. Tighten 1.5-3.0 Turns Past Finger Tight.
- Screw finger-tight Long High Pressure Hose to the 90° elbow fitting on pump. Use wrench to hold hose secure. Use other wrench to tighten fitting swivel. Tighten 1.5-3.0 Turns Past Finger Tight.

Tools Needed

- 1" Wrench
- 7/8" Wrench
- OR
- Crescent Wrench (2 Needed)

Part Needed from Log Splitter Box:

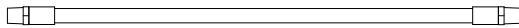

Valve to Hydraulic Pump

High Pressure Hose, 56" x 1/2" ID with
1/2" Male NPT fittings
Qty 1

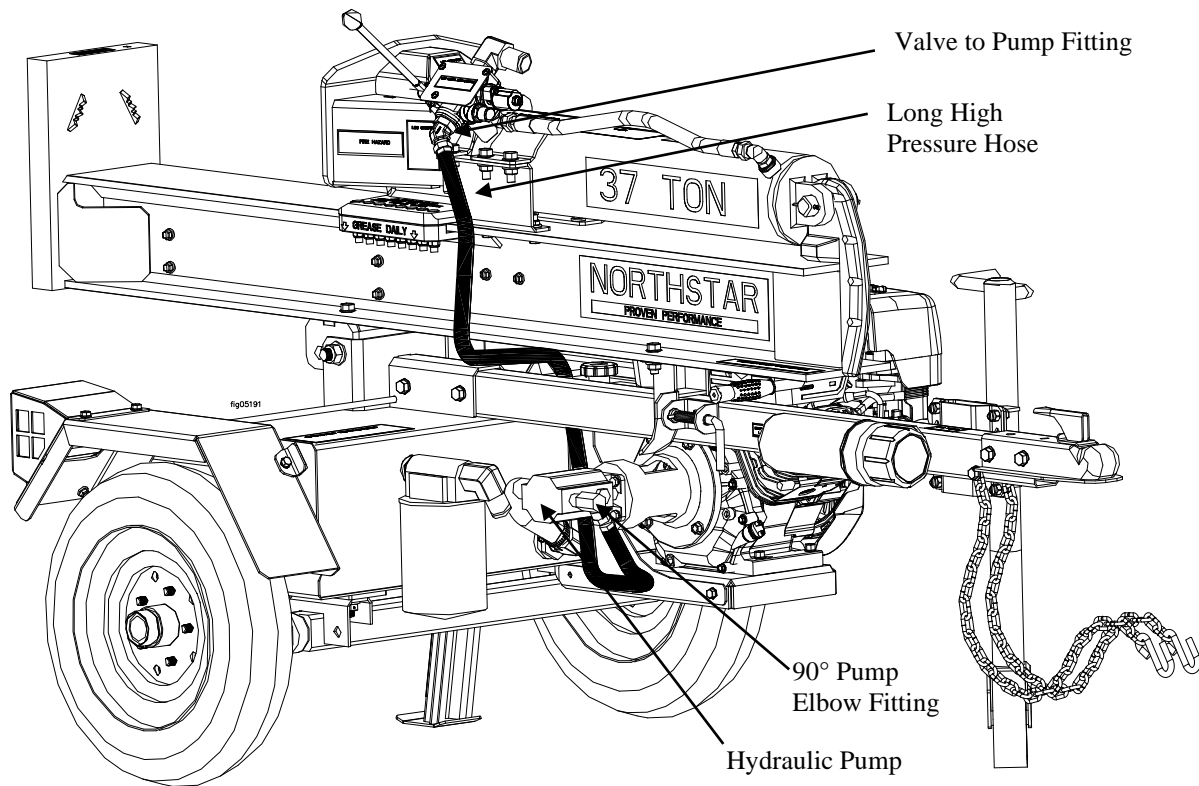

Assembly Instructions

Step 18 – Return Line Hose Routing

- Route (1) Valve to Return Line Filter Hose from Valve to Hydraulic Filter Fitting to filter fitting as shown below.
- Secure both ends of hose with hose clamp. Torque to 50 in.-lb.

Tools Needed

- Flat Blade Screw Driver
- Pipe Wrench
- Torque Wrench

Parts Needed from Log Splitter Box and Parts Bag:

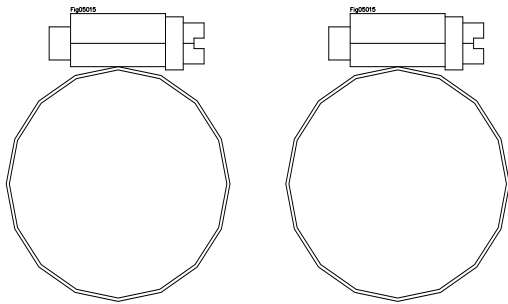

**Valve to Filter
Hose Clamp**
Qty 2

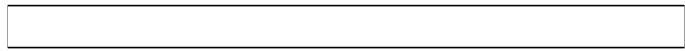

Valve to Return Line Filter Hose
Part# 790486
Qty 1

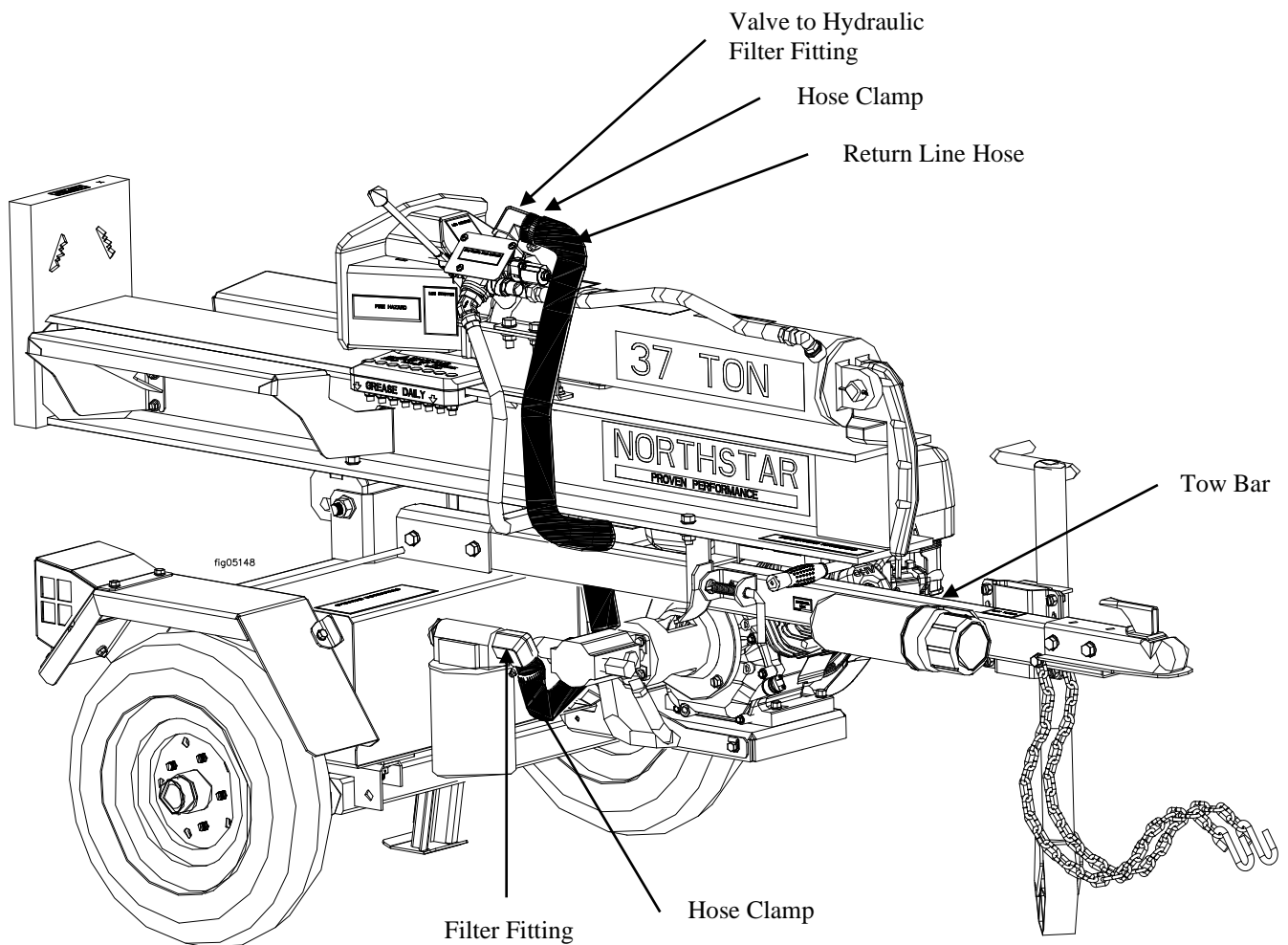

Limited Warranty

Dear Valued Customer:

The NorthStar Product you just purchased is built with the finest material and craftsmanship. Use this product properly and enjoy the benefits from its high performance. By purchasing a NorthStar product, you show a desire for quality and durability. Like all mechanical equipment this unit requires a due amount of care. Treat this unit like the high quality piece of machinery it is. Neglect and improper handling may impair its performance. Please thoroughly read the instructions and understand the operation before using your product. Always contact NorthStar Product Support at 1-800-270-0810 prior to having any service or warranty work performed, as some services performed by parties other than NorthStar approved service centers may void this warranty. This warranty is in lieu of any other warranty expressed or implied and NorthStar assumes no other responsibility or liability outside that expressed within this warranty.

Limited Warranty

NorthStar shall warranty any piece of equipment manufactured, or parts of equipment manufactured, to be free from defects in material or workmanship for a period of:

NorthStar Warranty		
Item #	Consumer Warranty Period	Commercial Warranty Period
1118	4 years from date of purchase by user	1 year from date of purchase by user

Engine Warranty		
Item #	Consumer Warranty Period	Commercial Warranty Period
1118	3 years from date of purchase by user	3 years from date of purchase by user

“Consumer use” means personal residential household use by a consumer. “Commercial use” means all other uses, including use for commercial, income producing or rental purposes or when purchased by a business.

This warranty applies to the original purchaser of the equipment (verification of purchase, in the form of a receipt, is the responsibility of the buyer), is non-transferable, and covers parts and labor. Parts will be replaced or repaired at no charge, except when the equipment has failed due to lack of proper maintenance. If a part is no longer available, the part may be replaced with a similar part of equal function. Any misuse, abuse, alteration or improper installation or operations will void warranty. Determining whether a part is to be replaced or repaired is the sole decision of NorthStar. NorthStar will not provide for replacement of complete products due to defective parts. Any costs incurred due to replacement or repair of items outside of a NorthStar approved facility is the responsibility of the buyer and not covered under warranty. Transportation costs to and from service center is the responsibility of the customer.

In addition to the normal warranty, NorthStar shall warrant any normal wear item from defects in material or workmanship for a period of 90 days from the date of purchase by user. Normal wear items include, but are not limited to, tires and filter elements.

This warranty specifically excludes the following; failure of parts due to damage caused by accident, fire, flood, windstorm, acts of God, applications not approved by NorthStar in writing, corrosion caused by chemicals, use of replacement parts which do not conform to manufacturer’s specifications, damage related to rodent and/or insect infestation and damage caused by vandalism. Additional exclusions: loss of running time, inconvenience, loss of income, or loss of use, including any implied warranty of merchantability of fitness for a specific use. Also, Outdoor Power Equipment needs periodic parts and service to perform well, and this warranty does not cover instances when normal use has exhausted the life of a component or the engine.

This warranty does not cover any personal injury or damage to surrounding property caused by failure of any part. Repair or replacement of parts does not extend the warranty period.

The engine warranty is covered under the terms and conditions as outlined by the engine manufactures warranty contained herein and is the sole responsibility of the engine manufacture. Normal engine maintenance such as spark plugs, air filters, adjustments, fuel system cleaning and obstruction due to build up is not covered by this NorthStar warranty.

Please fill in the following information and have it on hand when you call in on a warranty claim.

Customer Number: _____

Date of Purchase: _____

NorthStar Serial Number: _____

Item Number: _____

⚠WARNING: This product can expose you to chemicals including gasoline engine exhaust, which is known to the State of California to cause cancer, and carbon monoxide, which is known to the State of California to cause birth defects or other reproductive harm.

For more information go to www.P65Warnings.ca.gov.



Manufactured by
Northern Tool + Equipment Co., Inc.
Burnsville, MN 55306
NorthernTool.com