



M1107E

ITEM NUMBER: 1107

SERIAL NUMBER: _____

Owner's Manual

Instructions for Assembly, Testing, Operation, Servicing, & Storage

20 Ton Log Splitter: Outdoor hydraulic powered machine that splits wood logs.

⚠ WARNING

READ and UNDERSTAND this manual completely before using log splitter.

All operators of this equipment must read and completely understand all safety information, operating instructions, maintenance and storage instructions. Failure to properly operate and maintain the log splitter could result in serious injury to the operator and bystanders from moving parts that can crush or cut, flying objects, burns, fire or explosion, escaping high pressure hydraulic fluid, or carbon monoxide poisoning in particular, be aware of the following hazards.

Crush and Cut Hazards

Moving parts can crush and cut hands and fingers. Keep hands clear of endplate, wedge, and logs while splitting.

High Pressure Hydraulic Fluid Hazards

High fluid pressures and temperatures are developed in hydraulic Log splitters. Hydraulic fluid escaping through even a pin-size hole opening can puncture skin and cause severe blood poisoning. Inspect hydraulic system regularly for possible leaks. Never check for leaks with your hand while the system is pressurized. Seek medical attention immediately if injured by escaping fluid.

Fire Hazards

- If your log splitter is intended for use near and ignitable forest, brush, or grassy covered land, the engine exhaust should be equipped with a spark arrestor. See the "Specifications" section of this manual to determine if your splitter is equipped already has a spark arrestor. If not equipped, call NorthStar Product Support for ordering information.
- Keep a fire extinguisher with you, that is rated for ordinary combustibles and flammable liquids.

STOP!

ADD OIL TO ENGINE BEFORE USING: Engine is shipped without oil. DO NOT start log splitter without first adding oil.

VERIFY HYDRAULIC OIL LEVEL: Hydraulic reservoir is shipped with oil. Verify oil level is 1" from top before using.

INSPECT COMPONENTS: Closely inspect to make sure no components are missing or damaged.

See "Initial Unpacking and Setup" section for instructions and whom to contact to report missing or damaged parts.

Any Questions, Comments, Problems or Parts Orders

Call NorthStar Product Support 1-800-270-0810

Hazard Signal Word Definitions





	<p>This is the safety alert symbol. It is used to alert you to potential personal injury hazards. Obey all safety messages that follow this symbol to avoid possible injury or death.</p>
	<p>DANGER (red) indicates an imminently hazardous situation which, if not avoided, will result in death or serious injury.</p>
	<p>WARNING (orange) indicates a potentially hazardous situation which, if not avoided, could result in death or serious injury.</p>
	<p>CAUTION (yellow) indicates a potentially hazardous situation which, if not avoided, may result in minor or moderate injury.</p>
	<p>CAUTION (yellow) used without the safety alert symbol indicates a potentially hazardous situation which, if not avoided, may result in property damage.</p>

fig01453

Table of Contents

About Your Log Splitter.....	4
Safety label Locations.....	5
Machine Components Identification.....	7
Initial Unpacking & Set-up.....	8
Moving & Towing to the Job Site.....	10
Before Each Use:	
Step One: Inspection/Maintenance.....	13
Step Two: Refueling.....	15
Step Three: Work site Selection & Set-up.....	16
Splitting Operation.....	18
Storage.....	24
Periodic Maintenance	25
Troubleshooting.....	26
Specifications.....	27
Parts Breakdown – Exploded View.....	28
Summary of Important Safety Information for Operation.....	30

About Your Log Splitter

Thank you for purchasing your NorthStar log splitter!

About Your Log Splitter:

This log splitter is a machine designed to split wood logs using a hydraulically powered moving wedge. The log splitter's gasoline engine is used to pressurize the hydraulic system.

This log splitter is designed to split logs *up to 24" long, lengthwise with the grain only.*

Your splitter can be used in either a vertical or horizontal splitting position:

- When the splitter is set up to operate in the horizontal splitting position, a log is placed on the horizontal beam and the wedge moves horizontally into the end of the log to split it.
- When the splitter is set up to operate in the vertical splitting position, the log is placed on the endplate, upright on its end, and the wedge moves down into the top of the log to split it.

The horizontal splitting position is used for lighter logs that can be easily loaded onto the beam. The vertical splitting position is used for heavier logs that are difficult to load onto the beam.

The technical specifications for your log splitter are provided in the "Specifications" section of this manual.

WARNING

This log splitter uses a high-pressure hydraulic system to generate a very strong splitting force.

Read the manual completely before using the machine to understand how to safely operate and maintain it.

Follow all safety precautions presented throughout this manual. A summary of important safety information can be found at the end of this manual.

Contact NorthStar Product Support at 1-800-270-0810 for any questions about the appropriate use of this log splitter and /or optional accessories.

Warranty Registration:

Please fill out and submit the warranty registration card so that we have your contact information for any future product literature or replacement parts you may need.

Attention: All Rental Companies and Private Owners who loan this equipment to others!

All persons to whom you rent/loan the log splitter must have access to and read this manual. Keep this owner's manual with the splitter at all times and advise all persons who will operate the machine to read it. You must provide instruction on how to safely operate the splitter and remain available to answer any questions a renter/borrower might have.

Safety Label Locations

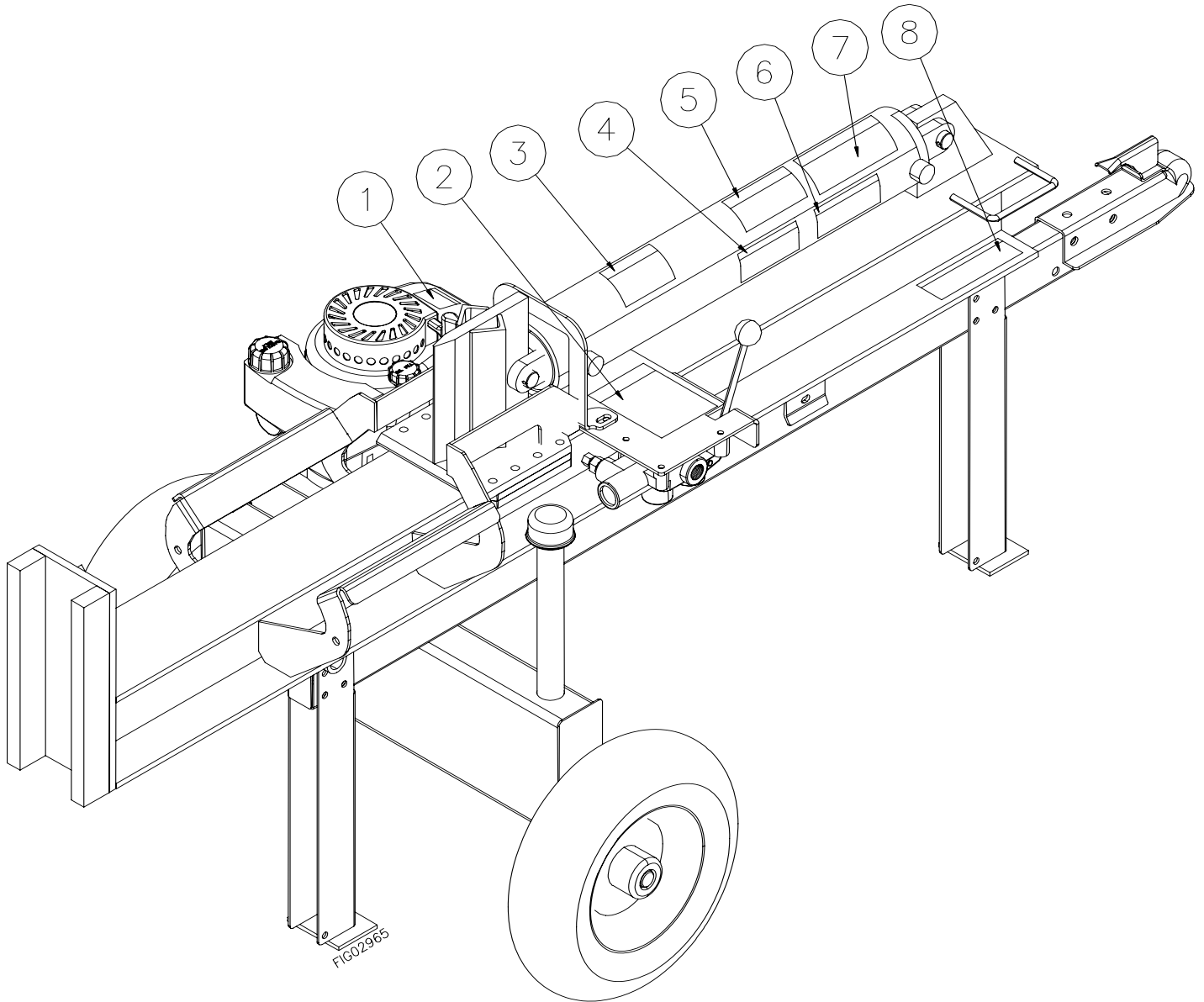

Ref #	Part #	Description
1	39260	Hot Muffler Decal
2	777886	Splitter Warning Decal
3	39259	Warning Decal
4	777887	Splitter Operating Instruction Decal
5	777890	Fire Hazard Warning Decal
6	777889	Stuck Log Warning Decal
7	777891	Hydraulic Fluid Warning Decal
8	777892	Moving/Towing Decal

Always make sure safety labels are in good condition. If a safety label is missing or not legible, order new labels or unsafe operation could result.

Safety Label Locations

1

SPLIT CONTROL LEVER OPERATION

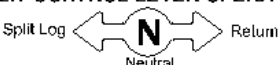

Split Log Neutral Return

WARNING

Moving parts can crush and cut. Pieces can fly out while splitting. Follow safety rules for operating the log splitter or serious injury could result.

- READ the Owner's Manual completely before operating.
- Only one person should operate the log splitter. If an assistant is helping to load logs, the operator should not actuate controls until the assistant is at least 10 ft away.
- Stay in the designated OPERATOR POSITION while actuating the controls.
- Split wood in direction of the grain only.
- Hold bark side of logs when loading.
- Keep hands away from wedge, endplate/ram, and partly split logs.
- Never leave log splitter unattended during operation.
- Stay off slopes and slippery surfaces.

See additional safety rules in the Owner's Manual.

© 2005 Vermeer Tool - Equipment Co. 1-800-270-6940 P# 777582

2

WARNING

BURN HAZARD
Do not touch hot muffler.



© 2005 Vermeer Tool - Equipment Co. 1-800-270-6940 P# 777582

3

WARNING

POISONOUS GAS

This product's use gives off carbon monoxide, an odorless gas that can kill you.

- ONLY use outdoors and away from air intakes.
- NEVER use inside homes, garages, or sheds, EVEN IF you run a fan or open doors and windows.

See product manual for more details.



© 2005 Vermeer Tool - Equipment Co. 1-800-270-6940 P# 777582

4

WARNING

ESCAPING HIGH PRESSURE HYDRAULIC FLUID HAZARD

High fluid pressures and temperatures are developed in the hydraulic system. Hydraulic fluid escaping through even a pin-size hole opening can puncture skin and cause blood poisoning.

- Inspect hydraulic system regularly for leaks.
- Never check for leaks with your hand while system is pressurized.
- Seek medical attention immediately if injured by escaping fluid.



© 2005 Vermeer Tool - Equipment Co. 1-800-270-6940 P# 777582

5

MOVING/TOWING INSTRUCTIONS

<p>Moving log splitter by hand:</p> <ul style="list-style-type: none"> • Lock beam in horizontal position (tip-up models only). • Lock lowbar leg in DOWN position. • Lock support leg in UP position (if equipped) • Do not attempt to move log splitter up or down slope by hand. 	<p>Towing log splitter:</p> <ul style="list-style-type: none"> • Latch coupler securely to class 2 or higher hitch with 2" ball. • Lock tow bar leg and support leg (if equipped) in the UP position. • Attach safety chains to tow vehicle. • Close fuel shut-off valve on engine (if equipped) • Do not tow faster than 45 mph. Higher speeds can cause loss of control. • Check local, state, and federal requirements before towing on public roads.
--	---

© 2005 Vermeer Tool - Equipment Co. 1-800-270-6940 P# 777582

6

WARNING

FIRE HAZARD

Hot exhaust can ignite dry brush, trees, or grass.

- Equip engine with a spark arrester if you will be using near ignitable forest, brush or grassy covered land.
- Keep a fire extinguisher on hand that is rated for ordinary combustibles & flammable liquids.



© 2005 Vermeer Tool - Equipment Co. 1-800-270-6940 P# 777582

7

OPERATING INSTRUCTIONS

GENERAL

- Stay in the OPERATOR POSITION while actuating controls.
- Never actuate controls until the helper is 10ft away from log splitter, including any helpers assisting to load logs.
- Wear eye protection, hearing protection, snug fitting gloves, and safety shoes or heavy boots. No loose or dangling apparel.

SETTING UP

- Place log splitter on dry, level ground.
- Secure splitter for unintended movement.
- Place splitter in horizontal or vertical position.
- Start engine

SPLITTING LOG

- Position log on beam, against endplate.
- Move split control to extend wedge and split log.
- Release split control to stop wedge.
- Move split control to return wedge.
- Remove split wood from work area.



Operator Position - horizontal

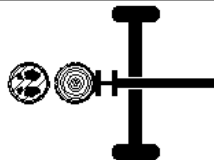

Operator Position - vertical

© 2005 Vermeer Tool - Equipment Co. 1-800-270-6940 P# 777582

8

WARNING

IF LOG BECOMES STUCK ON WEDGE

A log can become stuck to the wedge if the wedge becomes embedded in the log and the log doesn't split and separate. This can happen if the log is too stringy or tough to split completely.

A stuck log will move back with the wedge on the initial attempt to retract the wedge. **If this happens, STOP retracting the wedge immediately** and follow the directions below.

NEVER attempt to remove a stuck log by:

- Using the hydraulic force of the splitter
- Modifying the splitter
- Adding attachments to the splitter

Personal injury could result from log or metal pieces flying out at high speed toward the operator or bystanders, or the splitter could become damaged.

ALWAYS remove the log **MANUALLY** using the following procedure:

1. If there is already 1" or more of clearance between the log and endplate, go to step 2. Otherwise, retract wedge just enough to remove pressure between the log and endplate - about 1" clearance.
2. Turn engine OFF.
3. Remove stuck log from the wedge manually with a pry bar or sledgehammer. **Important:** Be extremely careful as log pieces may fly off as they separate from the wedge. Wear safety goggles and make sure bystanders are clear.
4. Do not attempt to resplit a stuck log once it has been removed from the wedge.

© 2005 Vermeer Tool - Equipment Co. 1-800-270-6940 P# 777582

FIG. 02253

Machine Component Identification

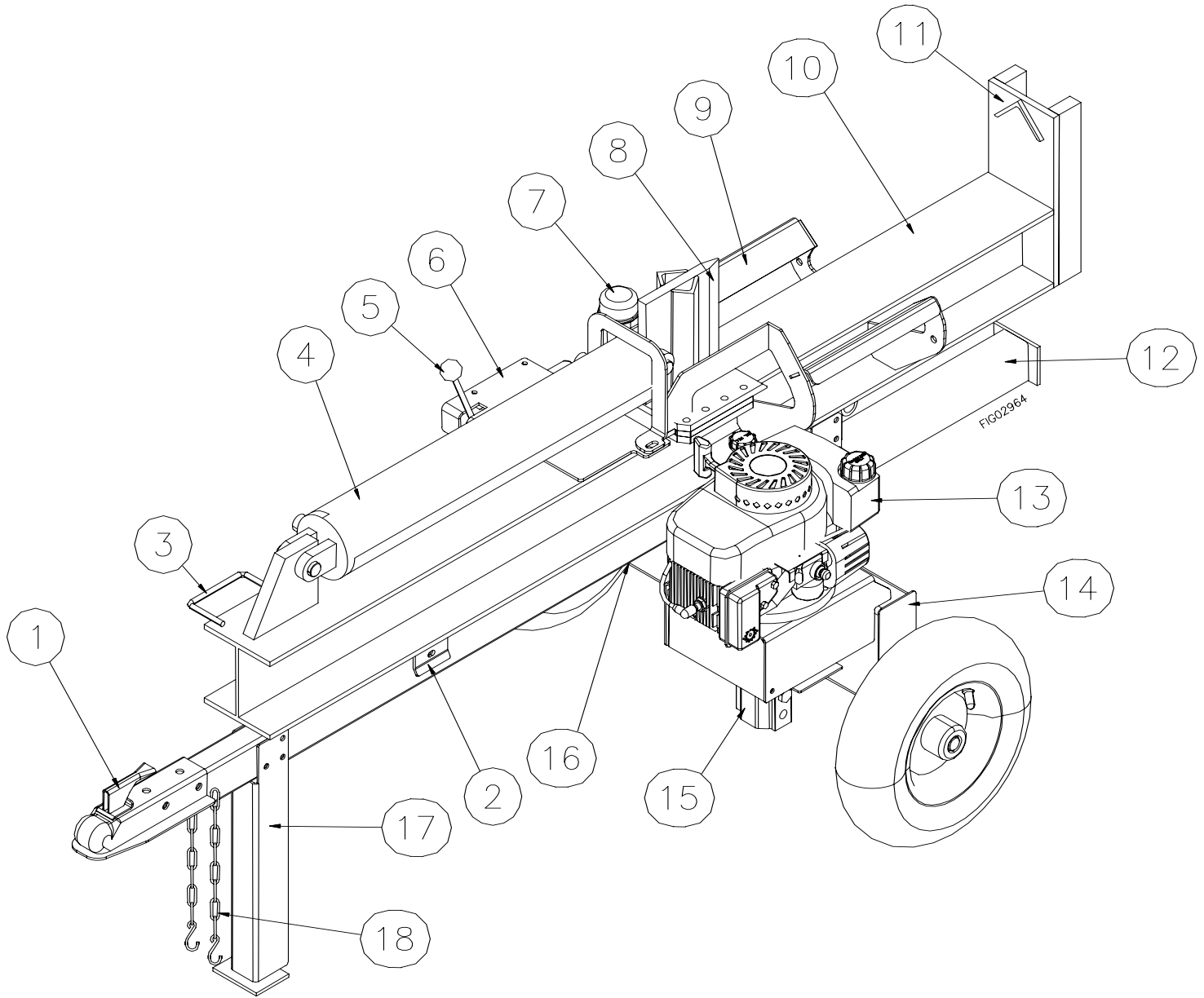

Ref	Description
1	2" Ball Coupler
2	Horizontal Lock
3	Lifting Handle
4	Cylinder
5	Split Control Lever
6	Control Valve
7	Hydraulic Oil Fill Cap
8	Wedge
9	Log Cradle

Ref	Description
10	Beam
11	Endplate
12	Support Leg
13	Engine
14	Hydraulic Tank
15	Pump
16	Suction Strainer
17	Tow bar Leg
18	Safety Chains

Initial Unpacking & Set-Up

IMPORTANT!

Engine is shipped without oil. DO NOT start the engine before adding oil.

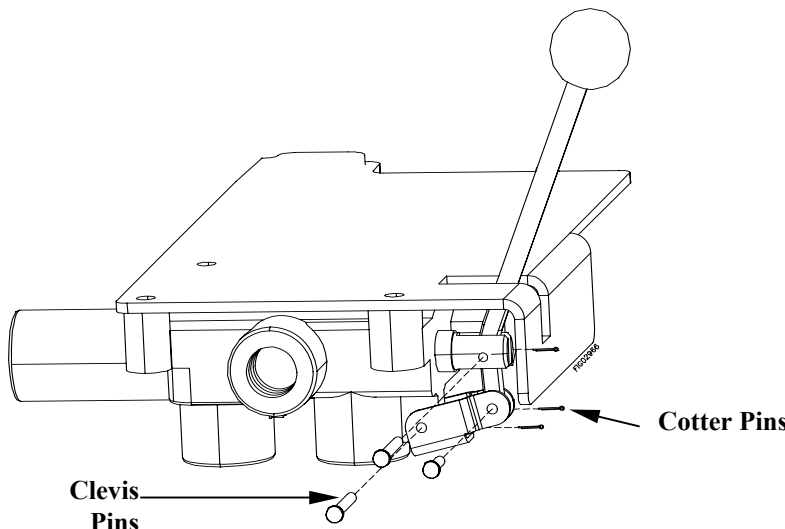
<p><u>Step One:</u> Add oil</p>	<p>Add oil to the engine. Using a funnel. Add SAE 30 oil up to the FULL mark on the dipstick. (See engine Owner's Manual for oil capacity and location of fill cap.)</p>
<p><u>Step Two:</u> Secure Split Control Lever</p>	<p>Secure Split Control Lever to Control Valve. Use following procedures:</p> <ol style="list-style-type: none"> 1. Split Control Lever is shipped taped to the hydraulic cylinder. Untape to release. 2. Raise lever to align lever hole with holes in valve bracket and insert clevis pin through the holes to put lever in the up position. 3. Secure by inserting cotter pin in end of clevis pin and spreading ends apart. <div style="text-align: center; margin-top: 20px;">  </div>
<p><u>Step Three:</u> Inspect Log Splitter Components.</p>	<p>Closely inspect all log splitter components. (See Machine Components section of this manual for diagram of components.)</p> <ul style="list-style-type: none"> • If you have missing components, contact Product Support at 1-800-270-0810. • If you have damaged components, contact the Freight Company that delivered the unit and file a claim.
<p><u>Step Four:</u> Verify Hydraulic Oil Level.</p>	<p>NOTE: Hydraulic reservoir is shipped <u>with</u> oil.</p> <ol style="list-style-type: none"> 1. Check hydraulic oil level: <ol style="list-style-type: none"> a) Make sure engine is off and the cylinder is fully retracted. b) Relieve all hydraulic system pressure by moving Split Control Lever back and forth several times. c) Remove Hydraulic oil fill cap. Verify that oil level is 1" from top of hydraulic reservoir (not including fill neck).

Initial Unpacking & Set-Up

⚠ WARNING: NEVER remove the hydraulic oil fill cap when the engine is running or hot. Hot oil can escape causing severe burns. Allow log splitter to cool completely before removing hydraulic oil fill cap.

2. If hydraulic oil level is low:

Add 10 wt. AW32, ASLE H-150, or ISO 32 oil to 1" from top.

Note: The log splitter comes filled with LIGHT 150-ISO 32 hydraulic oil. If the log splitter will be run for long periods of time in outdoor temperatures above 70°F, we recommend changing the hydraulic oil to DEXTRON III.

3. Replace fill cap.

Step Five:
Lubricate Slide
Rail Beam.

Lubricate the surface of the slide rail beam with engine oil. This will help prevent wear between the slide plates and beam.

Moving and Towing to Job Site

⚠ WARNING

The log splitter is heavy. It can crush and cause serious injury if it rolls out of control or tips over.

Follow the instructions below for safely moving and towing the log splitter.

Moving the log splitter:

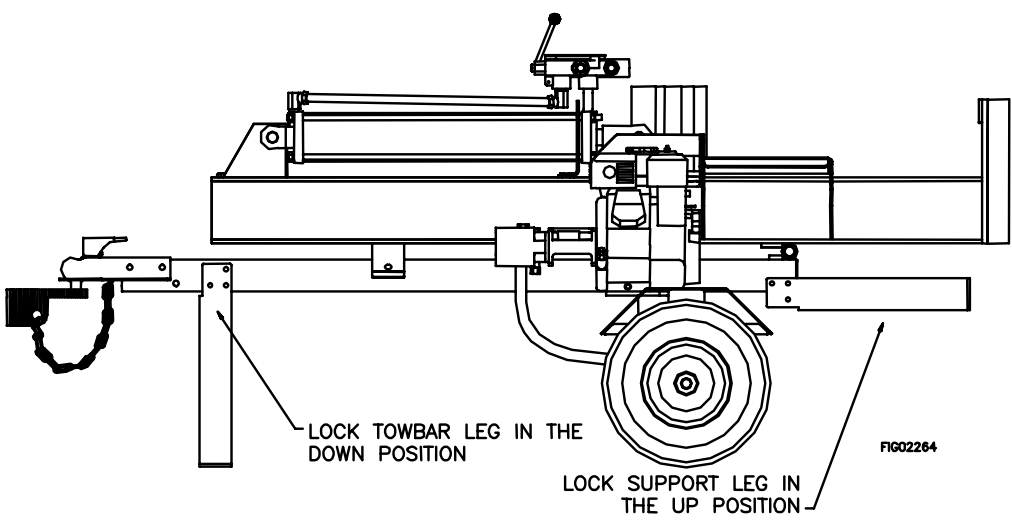
<p>1. Place in Horizontal position</p>	<p>Make sure the log splitter is secure in the horizontal position with hitch pin before moving.</p> <p>NEVER move log splitter when it is in vertical configuration because it will be unstable and could tip.</p>
<p>2. Engine off.</p>	<p>IMPORTANT: Make sure log splitter engine is off.</p> <p>Never move the log splitter with its engine running.</p>
<p>3. Fuel valve off</p>	<p>Turn fuel valve off to prevent carburetor flooding and reduce the chance of fuel leakage.</p>
<p>4. Lock:</p> <ul style="list-style-type: none"> • Front tow bar leg DOWN • Rear support leg UP 	<p>Lock the front <u>tow bar leg</u> in the “DOWN” position and the rear <u>support leg</u> in the “UP” position before you move the log splitter.</p> <div style="text-align: center;">  </div>
<p>5. Move log splitter to work site or tow hitch</p>	<p>Move log splitter by hand either directly to chosen work site or to vehicle hitch for towing.</p> <p>(See “Before Each Use” section for instructions on selecting a work site)</p> <p><u>Important Safety Instructions:</u></p> <ul style="list-style-type: none"> • Hills. Do not move the log splitter up or down hills by hand—use a towing vehicle. • No riding. Never allow anyone to sit or ride on the log splitter. • No cargo. Never transport cargo or wood on the log splitter.

Moving and Towing to Job Site

Towing:

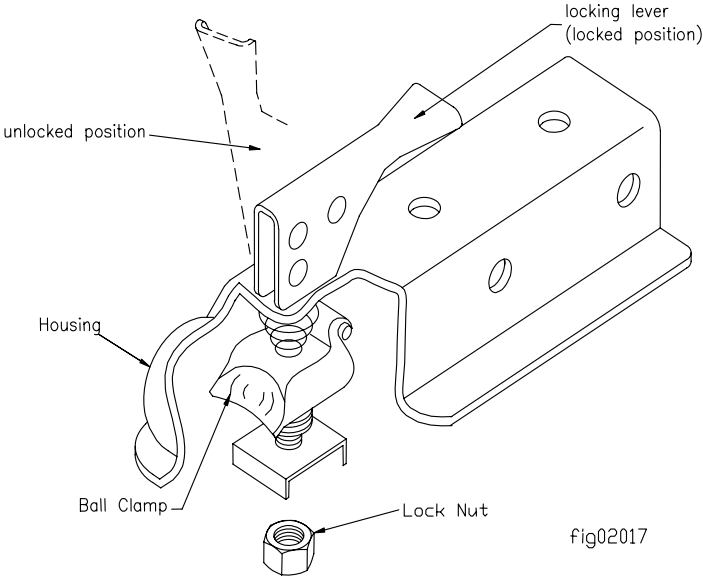
1. Read instructions	Review towing safety instructions in your vehicle manual.
2. Check tires	<p>Make sure tires are fully inflated and in good repair.</p> <p>⚠️ WARNING:</p> <ul style="list-style-type: none"> Do not over-inflate tires. Serious injury can occur if tire explodes. When seating a bead after repair, do not exceed 30 PSI. Pressures higher than 30 PSI can cause the tire and wheel to rupture and explode.
3. Attach to hitch (2" ball)	<p>Attach log splitter to vehicle hitch</p> <ol style="list-style-type: none"> 1) Attach log splitter's coupler to a class 2 or higher hitch with 2" ball (only). 2) Adjust coupler to ball by raising locking lever and turning lock nut with fingers. 3) Proper adjustment is obtained when coupler is as tight as possible on ball and locking lever can still be opened and closed. 4) Lock lever closed to secure the attachment. An optional locking pin or padlock may be inserted in the locking lever hole for extra security. <div style="text-align: center; margin-top: 10px;">  <p style="text-align: right; margin-right: 50px;">fig02017</p> </div>
4. Attach safety chains	<p>Attach safety chains.</p> <ol style="list-style-type: none"> 1. Two safety chains must be used while towing. 2. Cross safety chains under the coupler allowing only enough slack for vehicle turns.

Moving and Towing to Job Site

5. Put tow bar leg UP

Move the tow bar leg to the “UP” position and lock. (The support leg must remain in the up position during towing.)

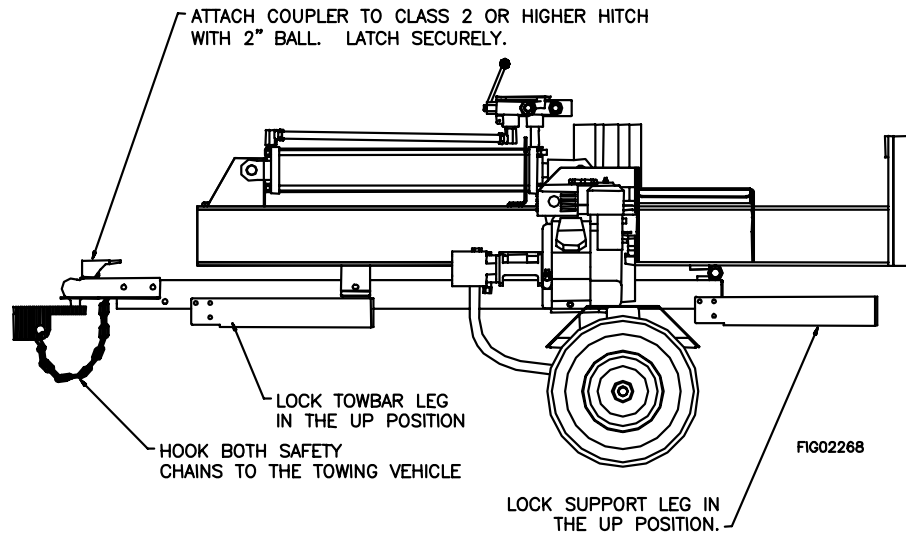

6. Tow to desired location

Tow log splitter carefully to desired work site.

(See “Before Each Use” section for instructions on selecting an appropriate work site)

Important safety instructions:

- **Added length.** Be aware of the added length of the splitter.
- **Speed limit.** Never tow this log splitter over 45 mph. Faster speeds may result in loss of control.
- **Rough terrain.** Drive slowly and take extra caution when traveling over rough terrain.
- **On public roads.** If towing on a public road, make sure to comply with all local, state, and federal towing requirements. It is the sole responsibility of the purchaser to obtain licensing, trailer lights, safety chains or signage, as needed to comply.
- **Unattended.** Turn off the towing vehicle before leaving the splitter unattended.
- **Under the influence.** Never tow or operate this splitter while under the influence of alcohol, drugs, or medication

7. Lock leg down & unhitch

Lock tow bar leg in the DOWN position and disconnect from vehicle.
NEVER operate log splitter while it is attached to the vehicle.

Before Each Use-Inspection / Maintenance

Step One: Inspect and maintain log splitter before each use

If the log splitter has been used previously, it must be inspected and maintained BEFORE EACH SUBSEQUENT USE.

 **WARNING**

ALWAYS shut off the engine, disconnect the spark plug, and relieve system pressure before inspecting, cleaning, adjusting, or repairing the splitter. Relieve system pressure by moving Split Control Lever back and forth several times.

IMPORTANT:

If a part needs replacement, only use parts that meet the manufacturer's specifications. Replacement parts that do not meet specifications may result in a safety hazard or poor operation of the log splitter.

1. Engine off / relieve pressure	<p>Perform all inspections/repairs with the engine off and hydraulic system pressure relieved.</p> <ol style="list-style-type: none"> 1. Make sure engine is off and cool. 2. Disconnect the spark plug 3. Relieve all hydraulic system pressure by moving the Split Control Lever back and forth several times.
2. Remove debris	<p>Remove debris from engine, muffler, and moving parts.</p> <ol style="list-style-type: none"> 1. <u>Engine debris</u>. Debris on a hot engine can be a fire hazard. Clean debris and chaff from engine cylinder head, cylinder head fins, blower housing rotating screen, and muffler areas. Avoid contact with hot muffler. 2. <u>Other debris</u>. Debris on moving parts can cause excess wear. Clear debris from the slide beam, wedge, and endplate.
3. Fuel tank / lines	<p>Check fuel tank and fuel lines for leaks.</p> <p>Any fuel leak is a fire hazard. Fix any fuel leaks before starting engine.</p>
4. Mechanical parts	<p>Check to be sure all nuts and bolts are tight to make sure the log splitter is in safe working condition.</p>
5. Hydraulic system	<p>Check the hydraulic system carefully:</p> <ol style="list-style-type: none"> 1. Visually inspect all hoses, tubing, clamps/fittings, pump, and cylinder for cracks, fraying, kinks, or other damage. 2. Check all components for oily residue, which may indicate a leak. <p>Do NOT operate the log splitter if there is any indication of damage or oily residue. Small leaks in hydraulic lines can cause severe injuries and can also be an indication of catastrophic failure in the near future. The life of hydraulic hoses may be from a few months to a few years, depending on use and storage patterns.</p> <p> WARNING: High fluid pressures and temperatures are developed in hydraulic log splitters. Hydraulic fluid escaping through a pin hole sized opening can burn or puncture skin, resulting in wounds that could cause blood poisoning, infection, disability, gangrene, amputation, or death. Therefore, the following instructions should be heeded at all times when inspecting or servicing the hydraulic components of the log splitter:</p>

Before Each Use-Inspection / Maintenance

	<ul style="list-style-type: none"> • Stop the engine, disconnect the spark plug, and move all control valve handles back and forth to relieve pressure before changing or adjusting hydraulic system components such as hoses, tubing, fittings or other components. • NEVER check for leaks with your hand. Leaks can be located by holding a piece of cardboard or wood (at least two feet long) with your hand at one end and passing the other end over the suspected area (wear eye protection). Look for discoloration of the cardboard or wood. • NEVER adjust the pressure setting of the pump or valve. • If injured by escaping fluid, no matter how small the wound is, see a doctor at once. A typical injection injury may be a small puncture wound that does not look serious. However, severe infection or reaction can result if proper medical treatment is not administered immediately by a doctor who is familiar with injection injuries.
6. Hydraulic oil level	<p>Make sure hydraulic oil level is 1” from top of hydraulic tank with cylinder retracted. Fill as needed.</p> <p><u>Note:</u> The log splitter comes filled with LIGHT 150-ISO 32 hydraulic oil. If the log splitter will be run for long periods of time in outdoor temperatures above 70°F, we recommend changing the hydraulic oil to DEXTRON III.</p> <p>⚠ WARNING: NEVER remove the hydraulic oil fill cap when the engine is running or hot. Hot oil can escape causing severe burns. Allow log splitter to cool completely before removing hydraulic oil fill cap.</p>
7. Engine	<p>Inspect and perform engine maintenance as directed in the engine manual.</p>
8. Spark arrestor muffler	<p>If the engine is equipped with a spark arrestor muffler, clean and inspect it regularly (follow spark arrestor manufacturer’s service instructions).</p> <p>Replace if damaged.</p>
9. Tires	<p>Make sure tires are fully inflated and in good repair if you will be towing the splitter. See tire sidewall for recommended tire pressure.</p> <p>⚠ WARNING:</p> <ul style="list-style-type: none"> • Do not over-inflate tires. Serious injury can occur if tire explodes. • When seating a bead after repair, do not exceed 30 PSI. Pressures higher than 30 PSI can cause the tire and wheel to rupture and explode.
10. Shields / guards	<p>Replace all guards and shields after servicing the log splitter.</p>

Before Each Use-Inspection / Maintenance

Step Two: Fueling



WARNING

Gasoline is highly flammable and explosive. You can be burned or seriously injured when handling fuel. Use extreme care when handling gasoline.

1. Engine off / cool	<p>The engine must be off and allowed to cool at least two minutes before adding fuel.</p> <p> WARNING: A running engine is hot enough to ignite fuel. Never add fuel or remove gas cap if engine is running or still hot.</p>
2. Outdoor location	<p>Fill fuel tank outdoors – never indoors.</p> <p> WARNING: Gasoline vapors can ignite if they collect inside an enclosure. Explosion can result.</p>
3. Remove gas cap	<p>Remove engine gas cap.</p>
4. Add gasoline	<p>Add gasoline through fill opening from a UL-approved container.</p> <p><u>Important Safety Instructions:</u></p> <ul style="list-style-type: none"> Use approved container. NEVER pump fuel directly into engine at gas station. Static charge can build and ignite fuel. Use a UL approved fuel container to transfer gas to the engine. Don't overfill. DO NOT overfill the gas tank. Allow at least 1/2" of empty space below the fill neck to allow for fuel expansion Heat / flames / sparks. Stay away from sources of heat, flame, or sparks while adding fuel.
5. Spills / splashes	<p>Clean up fuel spills /splashes immediately.</p> <ol style="list-style-type: none"> Move the log splitter away from spilled fuel on the ground. Wipe fuel off engine and wait 5 minutes for excess fuel to evaporate before starting engine. Gas soaked rags are flammable and should be disposed of properly. If gasoline is spilled on your skin or clothes, change clothes and wash skin immediately.
6. Replace gas cap	<p>Replace gas cap securely before starting engine.</p>
7. Gasoline storage	<p>Store extra gasoline in a cool, dry place in an UL approved, tightly sealed container.</p>

Before Each Use – Work Site Selection & Set-Up

Step Three: Work site selection and log splitter set-up

WARNING

It is important to select an appropriate work site and properly set up the log splitter in order to minimize the risk of slips and falls, equipment rolling or tipping over, carbon monoxide poisoning, and accidental fires.

1. Select location	<p>Select an appropriate location for operating the log splitter.</p> <p><u>Requirements:</u></p> <ol style="list-style-type: none"> 1. Dry-level surface with good footing. Stay clear of areas with mud, ice, tall grass, weeds, or brush. 2. Outdoors, away from air intakes. <p> WARNING: The running engine gives off carbon monoxide, a poisonous gas that can kill you. You CANNOT smell it, see it, or taste it.</p> <ul style="list-style-type: none"> • ONLY run log splitter <u>OUTDOORS</u> and away from air intakes. NEVER run log splitter inside homes, garages, sheds, or other buildings or semi-enclosed spaces. These spaces can trap poisonous gases, EVEN if you run a fan or open windows. • If you start to feel sick, dizzy, or weak while using the log splitter, shut off the engine and get to fresh air RIGHT AWAY. See a doctor. You may have carbon monoxide poisoning.
2. Fire precautions	<p>Take the following precautions against fire:</p> <ol style="list-style-type: none"> 1. <u>IMPORTANT:</u> If your splitter will be used near any unimproved forest, brush, or grassy covered land, <i>then engine must be equipped with a <u>spark arrestor</u>.</i> (See the “Specifications” section of this manual to determine if your splitter already has a spark arrestor. Contact NorthStar Product Support at 1-800-270-0810 for information about obtaining a spark arrestor for your log splitter if it is unequipped.) 2. Make sure you comply with applicable local, state and federal codes. 3. Keep a fire extinguisher available (classified for both ordinary combustibles & flammable liquids) as a precautionary measure when operating the log splitter in dry areas.
3. Position splitter 7’ from any combustibles or flammable liquids	<p>Position muffler at least 7 ft. from combustible objects during operation.</p> <p>Hot exhaust fumes from engine could cause fire. Also, hydraulic oil leaking or spraying on hot engine can ignite.</p>

Before Each Use – Work Site Selection & Set-Up

4. Lock both legs
DOWN

Lock both the support leg and the tow bar leg in the “DOWN” position.

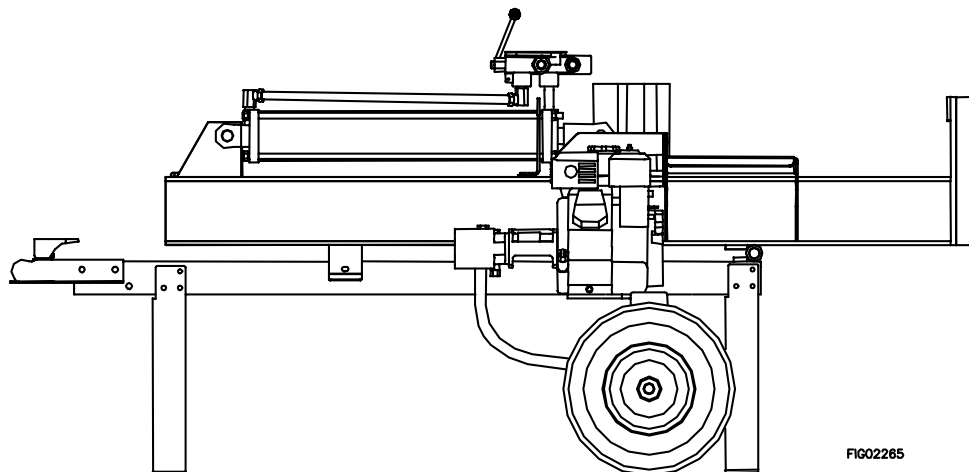

5. Block wheels

Block the wheels to prevent unintended movement of the log splitter.

Splitting Operation



WARNING

Before starting this log splitter, review the following instructions and safety information for safe operation of the log splitter.

Failure to follow these rules may result in serious injury to the operator or bystanders from moving parts that crush, cut, or entangle, from flying objects, burns, fire, falling or tripping, or from carbon monoxide poisoning.

General safety information:

- **Read manual.** Do not allow anyone to operate the log splitter who has not read the Owner's Manual or has not been instructed on the safe use of the splitter. The log splitter owner should instruct all operators in safe log splitter operation.
- **Age restrictions.** Never allow anyone under 16 years old to operate the log splitter. Children 16 years and older must be trained and supervised by a trained adult.
- **Intended use.** Log splitters should only be used for splitting wood logs, lengthwise with the grain. Do not use for other purposes as unforeseen hazards may result.
- **Modifications.** Never modify or alter the log splitter in any way. Modifications can create serious safety hazards and will void the warranty:
 - **Attachments.** Never add attachments to the splitter, except for authorized accessories supplied by the manufacturer with instructions for safe installation and use.
 - **Engine speed.** The maximum engine speed is preset at a safe limit. Never attempt to modify the engine speed setting to run at a higher speed.
 - **Fuel/exhaust system.** NEVER modify or add to the exhaust system, fuel tanks, or fuel lines. Fire can result.
 - **Remote control.** NEVER attach a rope, cable, or other remote device to the splitting control.
 - **Splitting wedge.** NEVER attempt to change the height or speed of the splitting wedge.
 - **Pressure setting.** NEVER increase the pressure setting of the pump or control valve.
- **Safety equipment / controls.** Always operate the log splitter with all safety equipment in place and in good working order, and all controls properly adjusted for safe operation.
- **Know how to stop.** Be thoroughly familiar with all controls and with the proper use of the equipment. Know how to stop the log splitter and relieve system pressures quickly if needed.
- **Operating speed.** Always operate the log splitter at the manufacturer's recommended speed. The maximum speed of the engine pump and wedge are preset within safe limits.
- **Daylight only.** Only use the log splitter in daylight so you can see what you are doing.
- **Smoking / sparks.** Never smoke while operating the log splitter, and never operate near sources of sparks or flames.
- **Under the influence.** Never operate, or let anyone else operate, the log splitter while under the influence of alcohol, drugs, or medication.
- **Unattended.** Never leave the machine unattended while the engine is running.
- **Refueling.** Never refuel the engine until it has cooled at least two minutes.
- **Adjusting / repairing.** Always make sure the engine is off before cleaning, repairing or adjusting the splitter, except as recommended by the manufacturer. In addition, disconnect the spark plug and move all control handles back and forth to relieve system pressure *before changing or adjusting hydraulic system components* such as hoses, tubing, fittings or other components.
- **Replace labels.** Always make sure safety labels are in place and in good condition. If a safety label is missing or not legible, order new labels because unsafe operation can result. Call 1-800-270-0810 to order new safety labels.

Splitting Operation

1. Put on protective clothing / gear

Wear the following protective clothing and safety gear:

- 1) **Eye protection.** Always wear safety glasses or goggles when operating the machine. Pieces of log may fly out and serious eye injury can occur.
- 2) **Boots.** Falling logs can crush feet. Always wear safety shoes or heavy boots when operating or helping to load logs.
- 3) **Gloves.** Wear snug fitting gloves without drawstrings or loose cuffs.
- 4) **Hearing protection.** The use of earplugs or other hearing protection device is recommended.
- 5) **No Loose / dangling.** Loose or dangling apparel can become entangled in moving parts. Never wear jewelry or loose-fitting clothing.

2. Lock & block

Block the wheels to prevent unintended movement of the log splitter. Check that:

- 1) The support leg and tow bar leg are both locked in the DOWN position.
- 2) The wheels are blocked.

3. Set to horizontal or vertical

Set log splitter into either the horizontal or vertical splitting position

The HORIZONTAL splitting position is used for lighter logs that can be easily loaded onto the beam. The VERTICAL splitting position is used for light logs as well as heavy logs that are difficult to load onto the beam.

Note:

Musculoskeletal injury can result from lifting logs onto the log splitter if proper lifting techniques are not used or the logs are too heavy for a person's size, weight, or strength. In some cases, logs as small as 8" in diameter and 14" in length may be heavier than what some persons should be repeatedly lifting onto the splitter.

The use of the vertical splitting position can greatly reduce the need to lift logs onto the splitter. Employers are advised to consider NIOSH lifting guidelines when assigning employees to log splitting tasks for an extended period of time.

⚠ WARNING: NEVER change splitting positions with the engine running. You may contact the muffler and receive serious burns.

a) *Set to Horizontal position*

Make sure beam is locked securely in the horizontal position by checking the horizontal lock.

Horizontal Splitting Position

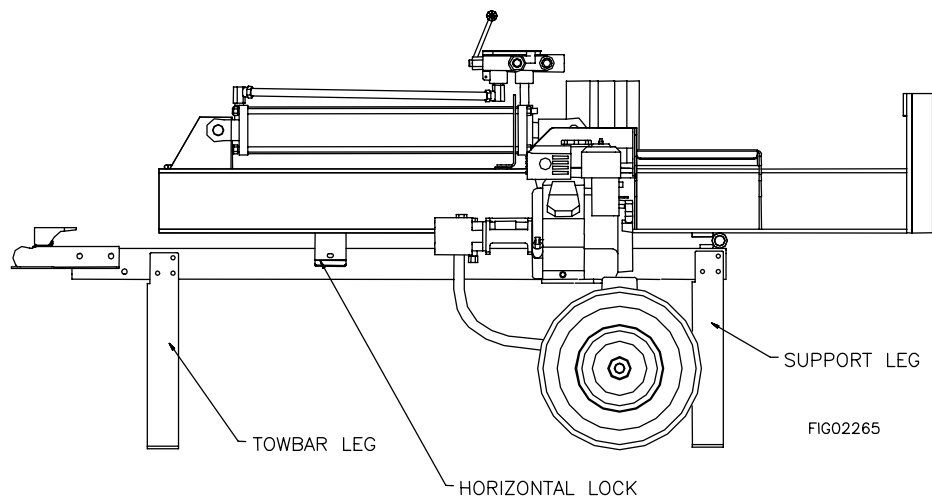

Splitting Operation

b) Set to Vertical position

- 1) Remove horizontal lock pin, grasp lifting handle and lift beam until it rotates into vertical position.

⚠ WARNING: Crush hazard. The beam is heavy – do not let it just drop. It could crush fingers or cause damage to the splitter.

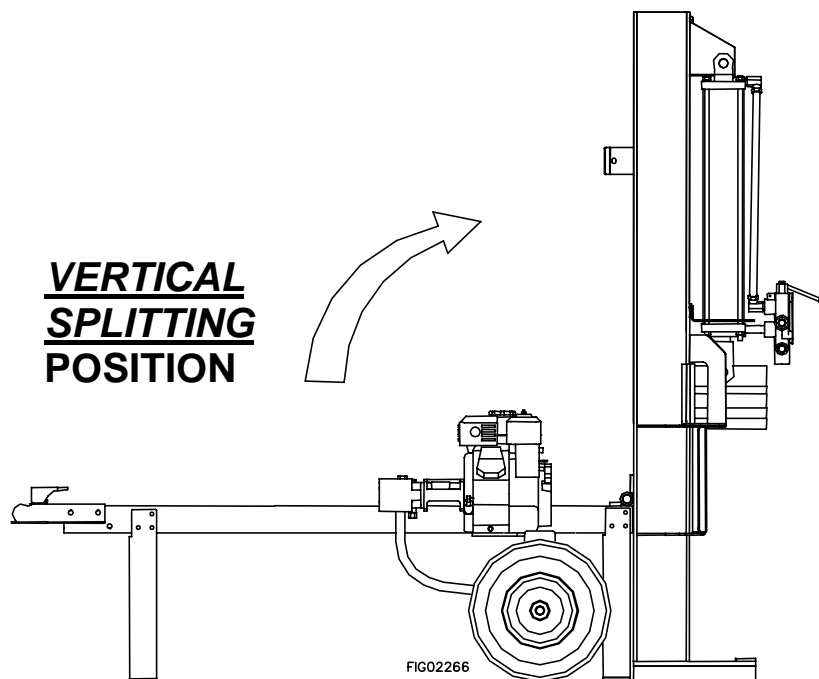

- 2) To return to horizontal position, grasp lifting handle and lower beam carefully in a controlled manner until it rests in the horizontal position, insert horizontal lock pin.

4. Start engine

Start the engine.

See the engine owner's manual for engine starting instructions.

NOTE:

- a) Make sure the hydraulic oil is above 10°F before starting the engine. Cold hydraulic oil can damage the hydraulic pump.
- b) If outdoor air temperature is below 32°F, allow log splitter to warm up by extending and returning the wedge several times before splitting wood.

⚠ WARNING:

Burns. To avoid burns, stay clear of hot muffler if you are starting a warm engine.

Carbon monoxide. The running engine gives off carbon monoxide, a poisonous gas that can kill you. You CANNOT smell it, see it, or taste it. If you start to feel sick, dizzy, or weak while using the log splitter, shut off the engine and get to fresh air RIGHT AWAY. See a doctor. You may have carbon monoxide poisoning.

Other exhaust dangers. Engine exhaust, some of its constituents, and certain vehicle components contain or emit chemicals known to the State of California to cause cancer, birth defects, or other reproductive harm. Avoid inhalation of exhaust.

Splitting Operation

5. Load log

Load log onto beam with a cut end against the endplate – positioned for a lengthwise cut.

Notes:

- The log splitter is designed only for cutting lengthwise with the grain, NOT for cutting across the grain.
- This log splitter is designed for cutting logs only up to a maximum of 24” long. Larger diameter logs could get stuck on the wedge and longer logs will not fit on the beam.

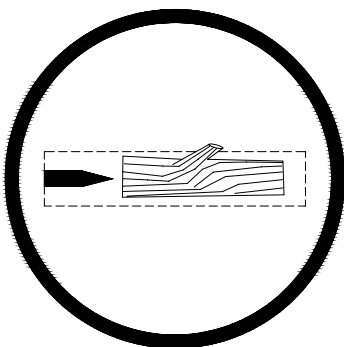

Correct Log Orientation

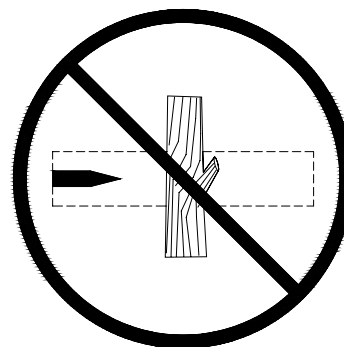

Incorrect Log Orientation

⚠ WARNING: ALWAYS keep hands and feet away from the endplate, wedge, and partially split logs while loading, operating and unloading the log splitter.

Important safety instructions:

- Hold bark side.** Hold the bark side of logs when loading or positioning, never the ends. Never place your hands or any part of your body between a log and any part of the log splitter.
- NOTE for vertical position loading:** Place the log on the endplate and turn it until it leans against the beam and is stable. If the log is too big or oddly shaped, stabilize the log with wooden shims between the log and endplate or ground. **DO NOT** use your leg or knee to stabilize the log. **NEVER** stabilize the log by placing your hand on top of the log.
- Wedge moving.** NEVER load or unload logs while the wedge is moving.
- Straddling / reaching across.** Never straddle, reach across, or step over the beam while the engine is running and the log splitter is in the horizontal position. You could trip, actuate the controls, and get seriously injured.
- Unsplit log pile.** Do not pile logs to be split in a place that will make you reach across the log splitter in order to load them.
- Square log ends.** Logs that are not cut square can slide out while splitting and become a safety hazard or cause excessive force to log splitter components. Use a chainsaw to cut logs square on each end before attempting to split them.
- Single log.** Never attempt to split more than one log at a time. Pieces of log can unexpectedly be thrown from the machine causing serious injury.
- Split along grain.** Do not use the log splitter to split logs across the grain. Doing so will damage the log splitter and could also cause pieces of log to be thrown, injuring the operator or bystanders.
- Changing splitting position.** Do not change splitting positions (horizontal/vertical) with the engine running. You may contact the muffler and receive serious burns. Be careful to avoid contact with hot muffler even after the engine is turned off.

Splitting Operation

6. Extend wedge

Move Split Control Lever toward endplate to extend wedge and split log.

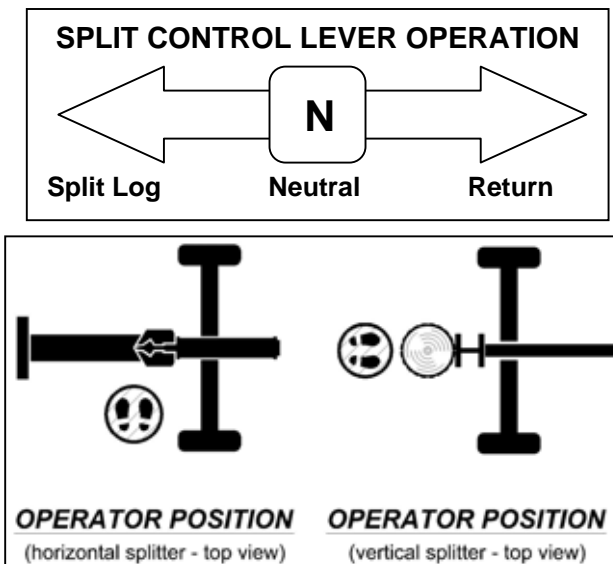

Important safety instructions:

- **Operator position.** ALWAYS operate the log splitter from the manufacturer's indicated OPERATOR POSITION. (See diagram above.) Other positions are unsafe because they can increase the risk of injury from crushing, cutting, flying objects, or burns.
- **Remove hands.** Remove both hands from log before activating Split Control Lever.
- **Hand activate.** Use only your hand to operate the Split Control Lever. Never use any other body part, or a rope, cable, or other remote device to actuate the control.
- **Second person.** Many accidents occur when there is more than one person involved in loading and operating the log splitter. Only one person should operate the controls. *If a second person is assisting in loading logs, the operator must NEVER actuate the Split Control Lever until the assistant and all bystanders are at least 10 feet away. NEVER allow an assistant to hold the log in place while the operator actuates the Split Control Lever.*

7. Stop wedge

Release Split Control Lever to stop wedge movement when log is split.

⚠️ WARNING: Cracks in logs can close quickly and pinch fingers. Keep fingers away from any cracks that open in partially split logs.

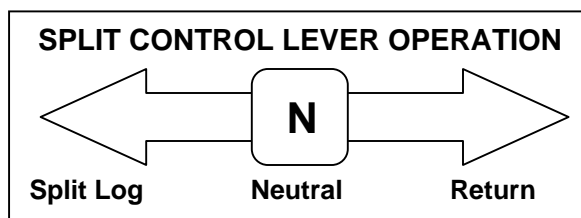

8. Important STUCK LOG procedure

If a log does not split completely and becomes stuck on the wedge, follow the instructions below to remove the log.

A log can become stuck to the wedge if the wedge becomes embedded in the log and the log doesn't split and separate. This can happen if the log is too stringy or tough to split completely.

A stuck log will move back with the wedge on the initial attempt to retract the wedge. If

Splitting Operation

this happens, **STOP** retracting the wedge immediately and follow the directions below.

⚠ WARNING: NEVER attempt to remove a stuck log by:

- Using the hydraulic force of the splitter.
- Modifying the splitter.
- Adding attachments to the splitter.

Personal injury could result from log or metal pieces flying out at high speed toward the operator or bystanders, or the splitter could become damaged.

1. If there is already 1” or more of clearance between the log and endplate, go to step 2. Otherwise, retract wedge just enough to remove pressure between the log and endplate – about 1” clearance. (Move split control to return, allow wedge to move about 1”, then stop the wedge by moving the split control to neutral “N”.)
2. Turn engine OFF.
3. Remove stuck log from the wedge **manually** with a pry bar or a sledgehammer.
Important: Be extremely careful as log pieces may fly off as they separate from the wedge. Make sure bystanders are clear and wear safety goggles.
4. Do not attempt to resplit a stuck log once it has been removed from the wedge. Manually split with an axe or cut with a chainsaw.

9. Return wedge

Move Split Control Lever away from end plate to return wedge.

Once the control valve is actuated in the return direction, the wedge is designed to keep returning by itself completely and then stop automatically.

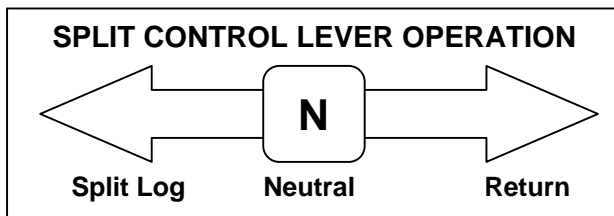

⚠ WARNING:

Stay clear while the wedge is returning. It is still powerful enough on the return stroke to cause serious injury.

10. Remove split wood

Remove split wood from area.

Move each log away from log splitter after it is split. Split logs left near the log splitter are a trip hazard.

11. After use

1. Turn off engine.

2. Remove engine debris.

Debris on a hot engine can be a fire hazard. After the engine is off, clean debris and chaff from engine cylinder head, cylinder head fins, blower housing rotating screen, and muffler areas.

⚠ WARNING: Avoid contact with hot muffler.

Return to horizontal position.



4. If in the vertical position, return log splitter to the horizontal position for greater stability and to prepare for transportation. Avoid contact with hot muffler.

Storage

WARNING

Gasoline vapors can ignite and cause a fire. Select a well-ventilated storage away from sources of heat, flame, or sparks.

Follow the instructions below for storing your log splitter between uses.

1. Retract wedge	Retract the wedge completely to keep the rod protected from corrosion.
2. Cool	<p>Allow the machine to cool 5 minutes before storing.</p> <p> WARNING: A hot engine can be a fire hazard.</p>
3. Wipe with oily rag	Wipe the beam and wedge with an oily rag to prevent corrosion.
4. Engine manual	<p>Refer to the engine manual for proper engine storage instructions.</p> <p>CAUTION: Gasoline will oxidize and deteriorate in storage. Old gasoline in the engine will cause hard starting and leave gum deposits that can clog the fuel systems. Deterioration problems may occur within a few months, or even less if gasoline was not fresh when you filled the tank.</p> <p><u>Short-Term Storage:</u></p> <ol style="list-style-type: none"> 1. Consider adding a fuel stabilizer to extend fuel storage life. 2. Leave the fuel valve lever in the OFF position to reduce the possibility of fuel leakage. <p><u>Long-Term Storage:</u> (between infrequent uses and at end of season) Drain the fuel tank and carburetor as instructed in the engine owner's manual.</p> <p><u>Important Safety Instructions</u></p> <ul style="list-style-type: none"> • Always drain fuel from tank in outdoor, well-ventilated area. • Stay away from sources of heat, flame, or sparks while handling fuel. • Clean up fuel spills/splashes immediately.
5. Splitter storage location	<p>Store the log splitter in a location away from corrosive material, sources of heat, open flames, sparks or pilot lights.</p> <p> WARNING: Never store log splitter inside where there is a source of heat or an open flame, spark or pilot light – such as water heaters, space heaters, furnaces, clothes dryers, or other gas appliances – EVEN IF the log splitter's gas tank is empty, residual gasoline vapors could ignite.</p> <p><u>NOTE:</u> Do not store the log splitter near fertilizer or any other corrosive material.</p>
6. Gasoline storage	<p>Store gasoline in a cool, dry place in an UL approved tightly sealed container.</p> <p> WARNING: Gasoline vapors can ignite if they collect inside an enclosure and explosion can result.</p>

Periodic Maintenance



In addition to the maintenance performed with each use, periodic maintenance should also be performed according to the following schedule.

WARNING

ALWAYS shut off the engine, disconnect the spark plug, and relieve system pressure before cleaning, adjusting, or repairing the splitter. Relieve system pressure by moving Split Control Lever back and forth several times.

IMPORTANT:

If a part needs replacement only use parts that meets the manufacturer’s specifications. Replacement parts that do not meet specifications may result in a safety hazard or poor operation of the log splitter.

1. Engine maintenance	Perform engine maintenance as specified in engine owner’s manual.
2. Hydraulic Oil Change	<p>Change Hydraulic Oil annually and/or 100 hours.</p> <p> WARNING: High fluid pressures and temperatures are developed in hydraulic log splitters. Hydraulic fluid escaping through a pin hole sized opening can burn or puncture skin, resulting in wounds that could cause blood poisoning, infection, disability, gangrene, amputation, or death. Therefore, the following instructions should be heeded at all times when inspecting or servicing the hydraulic components of the log splitter.</p> <ul style="list-style-type: none"> • NEVER check for leaks with your hand. Leaks can be located by holding a piece of cardboard or wood (at least two feet long) with your hand at one end and passing the other end over the suspected area (wear eye protection). Look for discoloration of the cardboard or wood. • NEVER adjust the pressure of the pump or valve. • If injured by escaping fluid, no matter how small the wound is, see a doctor at once. A typical injection injury may be a small wound that does not look serious. However, severe infection or reaction can result if proper medical treatment is not administered immediately by a doctor who is familiar with injection injuries. <ol style="list-style-type: none"> 1. Use 10wt AW32, ASLE H-150, or ISO32 oil. 2. Relieve hydraulic system pressure by moving Split Control Lever back and forth several times. 3. Remove hydraulic oil fill cap. <p> WARNING: NEVER remove the hydraulic oil fill cap when the engine is running or hot. Hot oil can escape causing severe burns. Allow the log splitter to cool completely before removing hydraulic oil fill cap.</p> <ol style="list-style-type: none"> 4. Remove the suction hose from the hydraulic tank to drain the hydraulic oil. 5. Fill to 1” from top of hydraulic tank with cylinder retracted. 6. Dispose of used oil at an oil recycling center. Used hydraulic oil is hazardous waste.
3. Spark arrestor muffler	If the engine is equipped with a spark arrestor muffler, clean and inspect it regularly (follow manufacturer’s service instructions). Replace if damaged.

Troubleshooting

WARNING

Before troubleshooting or attempting to service, read the following safety instructions to avoid serious injury to the operator or bystanders from moving parts that can crush or cut, burns, fire or explosion, or escaping high pressure hydraulic fluid.

Important Safety Instructions:

1. **Engine off.** Always make sure the engine is off before cleaning, repairing or adjusting the splitter, except as recommended by the manufacturer.
2. **Hydraulic safety.** High fluid pressures and temperatures are developed in the hydraulic log splitters. Hydraulic fluid escaping through a pin hole sized opening can burn or puncture skin, resulting in wounds that could cause blood poisoning, infection, disability, gangrene, amputation, or death. Therefore, the following instructions should be heeded at all times when inspecting or servicing the hydraulic components of the log splitter:
 - Stop the engine, disconnect the spark plug, and move all control valve handles back and forth to relieve pressure before changing or adjusting hydraulic components such as hoses, tubing, fittings, or other components.
 - Do not remove the hydraulic oil fill cap when the engine is running. Hot oil can escape causing severe burns. Allow the log splitter to cool completely before removing the hydraulic oil fill cap.
 - Do not adjust the pressure setting to the pump or valve.
 - Do not check for leaks with your hands. Leaks can be located by holding a piece of cardboard or wood (at least 2 feet long) with your hand at one end and passing the other end suspected area (wear eye protection). Look for discoloration of the cardboard or wood.
 - If injured by escaping fluid, no matter how small the wound is, see a doctor at once. A typical injection injury may be a small puncture that does not look serious. However, severe infection or reaction can result if proper medical treatment is not administered immediately by a doctor who is familiar with injection injuries.

Problem	
Wedge will not move	Solution: A,D,E,H,J
Slow wedge speed when extending or retracting	Solution: A,B,C,H,I,K
Wood will not split or splits extremely slow	Solution: A,B,C,F,I,K
Engine bogs down during splitting	Solution: G
Engine stalls under low load condition	Solution: D,E
Cause	Solution
A- Insufficient oil to pump	Check oil level in reservoir
B- Air in oil	Check oil level in reservoir, check for leaks in the suction line
C- Excessive pump inlet vacuum	Check pump inlet hose for blockage or kinks
D- Blocked hydraulic lines	Flush and clean the splitter hydraulic system
E- Blocked control valve	Flush and clean the splitter hydraulic system
F- Low control valve setting	Adjust control valve with a pressure gauge
G- High control valve setting	Adjust control valve with a pressure gauge
H- Damaged control valve	Return control valve for authorized repair
I- Internal control valve leak	Return control valve for authorized repair
J- Damaged cylinder piston	Return cylinder for authorized repair
K- Internally damaged cylinder	Return cylinder for authorized repair

Any Questions, Comments, Problems or Parts Orders
Call NorthStar Product Support 1-800-270-0810

Specifications

Maximum Pressure	3000 PSI
Maximum Flow	11 gpm
Hydraulic Fluid Capacity.....	3.5 gallons or 1” from top of hydraulic reservoir (not including fill neck).
Hydraulic Fluid Type.....	10wt AW32, ASLE H-150, or ISO32
Coupler Size.....	2” Ball
Maximum Towing Speed.....	45 MPH
Maximum Log Length	24 in
Pressure Relief Setting	3000 psi
Hydraulic Cylinder Bore	4 in
Hydraulic Cylinder Stroke	24 in
Spark Arrestor.....	No
Fuel Valve.....	No
Overall Dimensions	80”L x 40”W x 41”H
Dry Weight	450 LB

The manufacturer reserves the right to make improvements in design and/or changes in specifications at any time without incurring any obligation to install them on units previously sold.

Any Questions, Comments, Problems or Parts Orders
Call NorthStar Product Support 1-800-270-0810

Parts Breakdown - Exploded View - Rev E

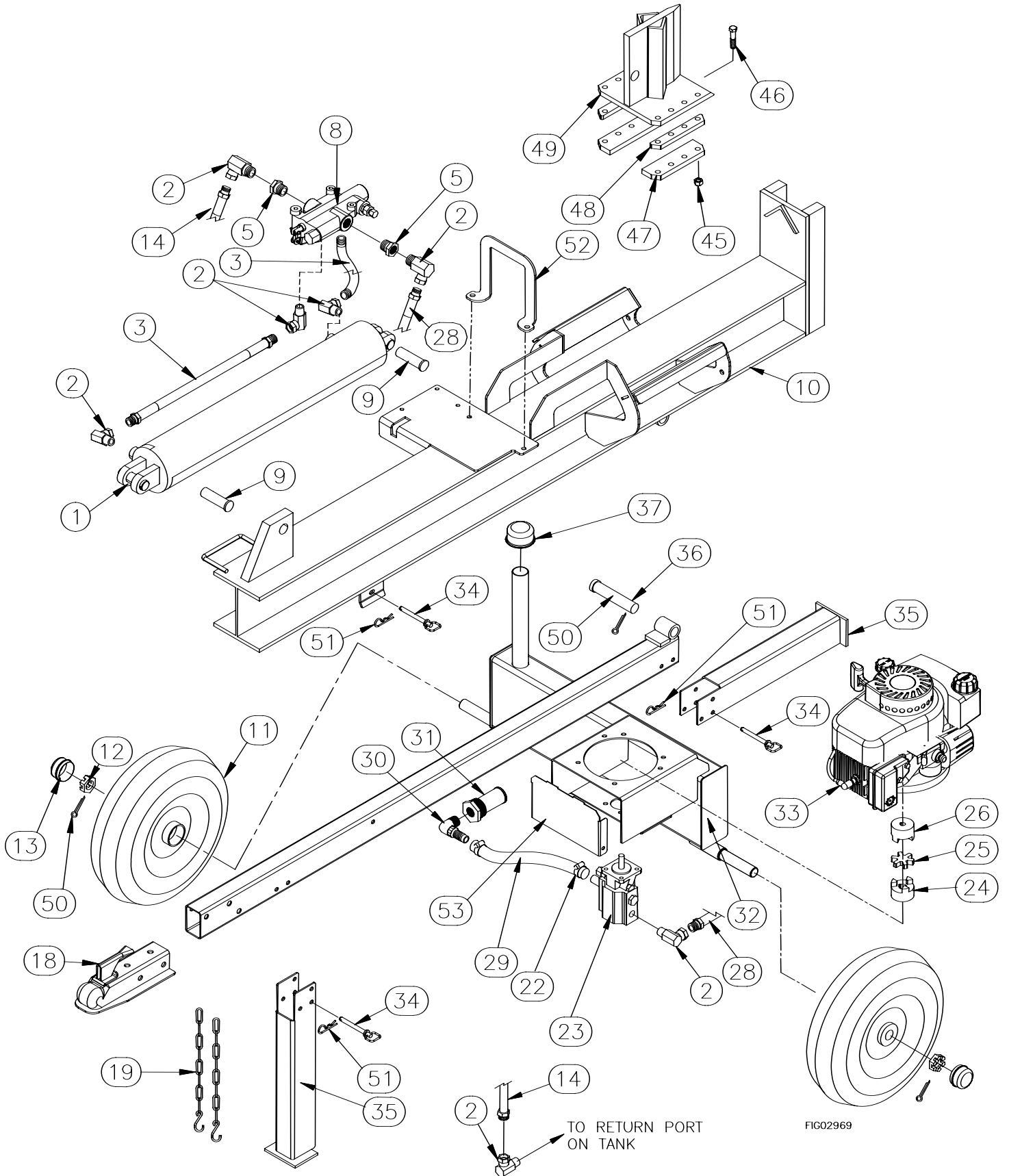

Parts Breakdown - Exploded View - Rev E

REF	PART#	DESCRIPTION	QTY
1	780405	Cylinder, 4" x 24"	1
2	50RAS8	½" NPT Elbow	7
3	777341	Hydraulic Hose, ½" x 25"	2
5	50CSC128	¾" NPT x ½" NPT Reducer	2
8	39238	Control Valve	1
9	406518	1" x 3" Pin	2
10	780975	Beam	1
11	777799	Tire	2
12	30028	Axle Nut	2
13	124A	Dust Cap	2
14	780976	Hydraulic Hose ½" x 48"	1
18	38587	2" Coupler	1
19	1130	Safety Chain	2
22	17141	Hose Clamp	2
23	1012	Pump	1
24	3002	Coupling, ½"	1
25	3009	Coupling insert	1
26	777885	Coupling 7/8"	1
28	780977	Hydraulic Hose ½" x 72"	1

REF	PART#	DESCRIPTION	QTY
29	30289	¾" Suction Hose	17"
30	50NBR12	¾" NPT x ¾" hose barb elbow	1
31	4011	Suction Strainer	1
32	779200	Towbar and Axle/Tank	1
33	779190	6.5 HP Briggs Engine	1
34	1176	3/8" x 3 3/8" Hitch Pin	3
35	38445	Support leg	2
36	406519	1" x 5" Pin	1
37	405A	Breather cap	1
45	82115	7/16" Nut	8
46	82114	7/16 x 2" Grade 8 Bolt	8
47	37024	Keeper plate	2
48	37025	Keeper spacer	2
49	38436	Wedge	1
50	82140	1/8" x 2" Cotter Pin	3
51	30312	1/8" Bridge Pin	3
52	38896	Hoop	1
53	778319	Love-Joy Shield	1

Summary of Important Safety Information for Operation

WARNING

Carefully read and make sure you understand the following safety information before using the log splitter. Improper use or maintenance of the log splitter can result in serious injury to the operator or bystanders from moving parts that can crush or cut, flying objects, burns, fire or explosion, escaping high pressure hydraulic fluid, or carbon monoxide poisoning.

Introduction

- **Read Manual.** Read this operator's manual and the engine Owner's Manual completely before attempting to use the log splitter. Serious injury or death can result if safety instructions are not followed.
- **Instruct operators.** The log splitter owner should instruct all operators in safe log splitter operation.
- **Intended use.** Log splitters should only be used for splitting wood logs, lengthwise with the grain. Do not use for other purposes, as unforeseen hazards may result.

Prohibition Against Modifications

Never modify or alter the log splitter in any way. Modifications can create serious safety hazards and will void the warranty.

- **Attachments.** Never add attachments to the splitter, except for authorized accessories supplied by the manufacturer with instructions for safe installation and use.
- **Engine Speed.** The maximum engine speed is preset at a safe limit. Never attempt to modify the engine speed setting to run at a higher speed.
- **Fuel/Exhaust system.** NEVER modify or add to the exhaust system, fuel tanks, or fuel lines. Fire can result.
- **Remote Control.** NEVER attach a rope, cable, or other remote device to the splitting control.
- **Splitting Wedge.** NEVER attempt to change the height or speed of the splitting wedge.
- **Pressure Setting.** NEVER increase the pressure setting of the pump or control valve.

Operator Restrictions

- **Untrained Operators.** Do not allow anyone to operate the log splitter who has not read the owner's manual or been instructed on the safe use of the splitter.
- **Minimum Operator Age.** Never allow anyone under age 16 to operate the log splitter. Children 16 years of age and older must be trained and supervised by a trained adult.

Safety in Moving and Towing the Log Splitter

WARNING

The log splitter is very heavy. It can cause serious injury if it rolls out of control or tips over. Follow the safety instructions below for safely moving the log splitter.

General safety while Moving

- **Horizontal position.** Make sure the log splitter is secured in the horizontal position before moving the log splitter. DO NOT move the log splitter when it is in the vertical position because it will be unstable and could tip.
- **Hills.** Do not move the log splitter up or down hills by hand – use a towing vehicle.
- **Engine off.** Never move the log splitter with its engine running.
- **No riding.** Never allow anyone to sit or ride on the log splitter.
- **No cargo.** Never transport cargo or wood on the log splitter.

Safety During Towing

- **Read instructions.** Review towing safety instructions in your towing vehicle manual.
- **Securely attached.** Be sure the log splitter is securely attached to the towing vehicle before towing.
- **Tires.** Be sure the tires are fully inflated and in good repair before towing the log splitter. When adding air to the tires, do not over-inflate – serious injury could occur if tire explodes.

Summary of Important Safety Information for Operation

- **Added length.** Be aware of the added length of the splitter.
- **Speed Limit.** Never tow this log splitter over 45 mph. Faster speeds may result in loss of control.
- **Rough terrain.** Be extra cautious and drive slowly when traveling over rough terrain.
- **Under the influence.** Never tow this splitter while under the influence of alcohol, drugs, or medication.
- **On public roads.** If towing on a public road, make sure to comply with all local, state, and federal towing requirements. It is the sole responsibility of the purchaser to obtain licensing, trailer lights, safety chains or signage, as needed to comply.
- **Unattended.** Turn off the towing vehicle before leaving the splitter unattended.
- **Disconnect before operate.** Do not use the log splitter while it is connected to the towing vehicle.

Safety – Before Use - Read/instruct

- **Read manual.** Do not allow anyone to operate the log splitter who has not read the owner's manual or has not been instructed on the safe use of the splitter.
- **Review safety rules.** Before starting this log splitter, review the "Rules for Safe operation." Failure to follow these rules may result in serious injury to the operator or bystanders.
- **Know how to stop.** Be thoroughly familiar with all controls and proper use of the equipment. Know how to stop the splitter and relieve system pressures quickly if needed.

Personal protective equipment

- **Eye protection.** Always wear safety glasses or goggles when operating the machine. Pieces of log may fly out and serious eye injury can occur.
- **Boots.** Falling logs can crush feet. Always wear safety shoes or heavy boots when operating or helping to load logs.
- **Loose/dangling.** Loose or dangling apparel can become entangled in moving parts. Never wear jewelry or loose-fitting clothing.
- **Gloves.** Wear snug fitting gloves without drawstrings or loose cuffs.
- **Hearing Protection.** The use of earplugs or other hearing protection device is recommended.

Safety During Inspection/Maintenance

Always inspect your log splitter before each use, and repair as needed, to keep it in safe working condition:

- **Engine off.** Always make sure the engine is off before cleaning, repairing or adjusting the splitter, except as recommended by the manufacturer.
- **Engine debris.** Debris on a hot engine can be a fire hazard. With the engine off, clean debris and chaff from engine cylinder head, cylinder head fins, blower housing rotating screen, and muffler areas. Avoid contact with hot muffler.
- **Other debris.** Debris on moving parts can cause excess wear. With the splitter engine off, clear debris from moving parts.
- **Fuel tank / lines.** Before each use, check fuel tank and fuel lines for leaks. Any fuel leak is a fire hazard. Fix any fuel leaks before starting engine.
- **Mechanical parts.** Check to be sure all nuts and bolts are tight to make sure the log splitter is in safe working condition.
- **Hydraulic system.** Check the hydraulic system (hoses, tubing, clamps/fittings, pump, and cylinder) carefully before each use. Do not operate the log splitter with frayed, kinked, cracked or damaged hydraulic hoses, fittings, or tubing, or if oily residue is observed on any of the components. High fluid pressures and temperatures are developed in the log splitter. Hydraulic fluid escaping through a pin hole sized opening can burn or puncture skin, resulting in wounds that could cause blood poisoning, infection, disability, gangrene, amputation, or death. Therefore, the following instructions should be heeded at all times when inspecting or servicing the hydraulic components of the log splitter:
 - Do not remove the hydraulic oil fill cap when the engine is running. Hot oil can escape causing severe burns. Allow log splitter to cool completely before removing hydraulic oil fill cap.
 - Do not adjust the pressure setting of the pump or valve.
 - Do not check for leaks with your hand. Leaks can be located by holding a piece of cardboard or wood (at least two feet long) with your hand at one end and passing the other end over the suspected area (wear eye protection). Look for discoloration of the cardboard or wood.

Summary of Important Safety Information for Operation

- Stop the engine, disconnect the spark plug, and move all control valve handles back and forth to relieve pressure before changing or adjusting hydraulic system components such as hoses, tubing, fittings or other components.
- If injured by escaping fluid, no matter how small the wound is, see a doctor at once. A typical injection injury may be a small puncture wound that does not look serious. However, severe infection or reaction can result if proper medical treatment is not administered immediately by a doctor who is familiar with injection injuries
- **Spark arrestor muffler.** If the engine is equipped with a spark arrestor muffler, clean and inspect it regularly (follow manufacturer's service instructions). Replace if damaged.
- **Tires.** Be sure tires are fully inflated and in good repair before towing the splitter. When adding air to tires, do not over-inflate -- serious injury could occur if tire explodes.
- **Guards / shields.** Make sure all guards and shields are replaced after servicing the log splitter.
- **Replacement parts.** If a part needs replacement, only use parts that meet the manufacturer's specifications. Replacement parts that do not meet specifications may result in a safety hazard or poor operation of the log splitter.

Safety During Fueling

Gasoline is highly flammable and explosive. You can be burned or seriously injured when handling fuel. Use extreme care when handling gasoline:

- **Fuel outdoors.** Fill fuel tank outdoors – never indoors. Gasoline vapors can ignite if they collect inside an enclosure. Explosion can result.
- **Use approved container.** Never pump fuel directly into engine at gas station. Static charge can build and ignite fuel. Use an UL approved fuel container to transfer gas to the engine.
- **Running / hot engine.** A running engine is hot enough to ignite fuel. Never add fuel or remove gas cap if engine is running or still hot. Stop the engine and allow to cool at least two minutes before adding fuel.
- **Heat / flames / sparks.** Stay away from sources of heat, flame, or sparks while adding fuel.
- **Don't overfill.** DO NOT overfill the gas tank. Allow at least 1/2" of empty space below the fill neck to allow for fuel expansion.
- **Replace cap.** Replace gas cap securely before starting engine.
- **Spills.** Clean up fuel spills immediately. Move log splitter away from spilled fuel on the ground. Wipe fuel off engine and wait 5 minutes for excess fuel to evaporate before starting engine. Gas soaked rags should be disposed of properly.
- **On skin / clothes.** If gasoline is spilled on your skin or clothes, change clothes and wash skin immediately.
- **Gasoline storage.** Store gasoline in a cool, dry place in an UL approved, tightly sealed container.

Safety in Work Site Selection

- **Spark arrestor.** If your splitter will be used near any unimproved forest, brush, or grassy covered land, then engine should be equipped with a spark arrestor. See the "Specifications" section of this manual to determine if your splitter already has a spark arrestor. Make sure you comply with applicable local, state and federal codes.
- **Hot exhaust.** Hot exhaust fumes from engine can cause fire. Position muffler at least 7' from combustible objects during operation.
- **Fire extinguisher.** Have a Class B fire extinguisher available as a precautionary measure when operating the log splitter in dry areas.
- **Level, dry surface.** To prevent accidental falls and equipment tip over, make sure the splitter is situated on a dry, level surface with good footing. Stay clear of areas with mud, ice, tall grass, weeds, or brush.
- **Block wheels.** Always block the wheels to prevent unintended movement of the log splitter.
- **Carbon monoxide.** The running engine gives off carbon monoxide, a poisonous gas that can kill you. You CANNOT smell it, see it, or taste it. ONLY run log splitter OUTDOORS and away from air intakes. NEVER run log splitter inside homes, garages, sheds, or other semi-enclosed spaces. These spaces can trap poisonous gases, EVEN if you run a fan or open windows. If you start to feel sick, dizzy, or weak while using the log splitter, shut off the engine and get to fresh air RIGHT AWAY. See a doctor. You may have carbon monoxide poisoning.

Summary of Important Safety Information for Operation

Safety – During Use

General Safety During Use

⚠️ WARNING: Before starting this log splitter, review the following rules for safe operation. Failure to follow these rules may result in serious injury to the operator or bystanders.

- **Safety equipment / controls.** Always operate the log splitter with all safety equipment in place and in good working order, and all controls properly adjusted for safe operation.
- **Operating speed.** Always operate the log splitter at the manufacturer's recommended speed. The maximum speed of the engine, pump and wedge are preset within safe limits.
- **Know how to stop.** Be thoroughly familiar with all controls and with the proper use of the equipment. Know how to stop the log splitter and relieve system pressures quickly if needed.
- **Daylight only.** Only use the log splitter in daylight so you can see what you are doing.
- **Smoking / sparks.** Never smoke while operating the log splitter, and never operate near sources of sparks or flames.
- **Hot muffler.** If you are starting a warm engine, stay clear of muffler. It may still be hot enough to burn you.
- **Unattended.** Never leave the machine unattended while the engine is running.
- **Under the influence.** Never operate, or let anyone else operate, the log splitter while under the influence of alcohol, drugs, or medication.
- **Adjusting / repairing.** Always make sure the engine is off before cleaning, repairing or adjusting the splitter, except as recommended by the manufacturer. In addition, disconnect the spark plug and move all control handles back and forth to relieve system pressure *before changing or adjusting hydraulic system components* such as hoses, tubing, fittings or other components.
- **Carbon monoxide.** The running engine gives off carbon monoxide, a poisonous gas that can kill you. You CANNOT smell it, see it, or taste it. If you start to feel sick, dizzy, or weak while using the log splitter, shut off the engine and get to fresh air RIGHT AWAY. See a doctor. You may have carbon monoxide poisoning.
- **Other exhaust dangers.** Engine exhaust, some of its constituents, and certain vehicle components contain or emit chemicals known to the State of California to cause cancer, birth defects, or other reproductive harm. Avoid inhalation of exhaust.

Safety in Loading, Operating, and Unloading

- **Square log ends.** Logs that are not cut square can slide out while splitting and become a safety hazard or cause excessive force to log splitter components. Use a chainsaw to cut logs square on each end before attempting to split them.
- **Single log.** Never attempt to split more than one log at a time. Pieces of log can unexpectedly be thrown from the machine causing serious injury.
- **Split along grain.** Do not use the log splitter to split logs across the grain. Doing so will damage the log splitter and could also cause pieces of log to be thrown, injuring the operator or bystanders.
- **Keep hands clear.** ALWAYS keep hands and feet away from the endplate, wedge, and partially split logs while loading, operating and unloading the log splitter.
- **Operator position.** ALWAYS operate the log splitter from the manufacturer's indicated OPERATOR POSITION. Other positions are unsafe because they can increase the risk of injury from crushing, cutting, flying objects, or burns.
- **Straddling / reaching across.** Never straddle, reach across, or step over the beam while the engine is running and the log splitter is in the horizontal position. You could trip, actuate the controls, and get seriously injured.
- **Second person.** Many accidents occur when there is more than one person involved in loading and operating the log splitter. Only one person should operate the controls. *If a second person is assisting in loading logs, the operator must NEVER actuate the Split Control Lever until the assistant and all bystanders are at least 10 feet away. NEVER allow an assistant to hold the log in place while the operator actuates the Split Control Lever.*
- **Loading/Unloading**
 - **Unsplit log pile.** Do not pile logs to be split in a place that will make you reach across the log splitter in order to load them.
 - **Hold bark side.** Hold the bark side of logs when loading or positioning, never the ends. Never place your hands or any part of your body between a log and any part of the log splitter.

Summary of Important Safety Information for Operation

- **NOTE for vertical position loading:** Place the log on the endplate and turn it until it leans against the beam and is stable. If the log is too big or oddly shaped, stabilize the log with wooden shims between the log and endplate or ground. DO NOT use your leg or knee to stabilize the log. NEVER stabilize the log by placing your hand on top of the log.
- **Wedge moving.** NEVER load or unload logs while the wedge is moving.
- **Cracks.** Cracks in logs can close quickly and pinch fingers. Keep fingers away from any cracks that open in partially split logs.
- **Split log pile.** Move each log away from log splitter after it is split. Split logs left near the log splitter are a trip hazard.
- **Remove hands.** Remove both hands from log before activating Split Control Lever.
- **Hand activate.** Use only your hand to operate the Split Control Lever. Never use any other body part, or a rope, cable, or other remote device to actuate the control.
- **Returning wedge.** Once the control valve is actuated in the return direction, the wedge is designed to keep returning by itself completely and then stop automatically. Stay clear while the wedge is returning. It is still powerful enough on the return stroke to cause serious injury.
- **Log stuck on wedge.** A log can become stuck to the wedge if the wedge becomes embedded in the log and the log doesn't split and separate. This can happen if the log is too stringy or tough to split completely. A stuck log will move back with the wedge on the initial attempt to retract the wedge. If this happens, **STOP** retracting the wedge immediately and follow the directions below to manually remove the log:
 - IMPORTANT:** NEVER attempt to remove a stuck log by using the hydraulic force of the splitter, or by modifying or adding attachments to splitter. Personal injury could result from log or metal pieces flying out at high speed toward the operator or bystanders, or the splitter could become damaged.
 - 1. If there is already 1" or more of clearance between the log and endplate, go to step 2. Otherwise, retract wedge just enough to remove pressure between the log and endplate – about 1" clearance. (Move split control to return, allow wedge to move about 1", then stop the wedge by moving the split control to neutral "N".)
 - 2. Turn engine OFF.
 - 3. Remove stuck log from the wedge **manually** with a pry bar or a sledgehammer. Be extremely careful, as log pieces may fly off as they separate from the wedge. Wear safety goggles and make sure bystanders are clear. Do not attempt to resplit a stuck log once it has been removed from the wedge.
- **Changing splitting position.** Do not change splitting positions (horizontal/vertical) with the engine running. You may contact the muffler and receive serious burns. Be careful to avoid contact with hot muffler even after the engine is turned off.
- **Refueling.** Never refuel the engine until it has cooled at least two minutes.

Safety – After use

- **Return to horizontal.** If in the vertical position, turn off engine and return log splitter to the horizontal position for greater stability and to prepare for transportation. Avoid contact with hot muffler
- **Remove engine debris.** Debris on a hot engine can be a fire hazard. With the engine off, clean debris and chaff from engine cylinder head, cylinder head fins, blower housing rotating screen, and muffler areas. Avoid contact with hot muffler.
- **Let engine cool before storing.** Let engine cool for at least five minutes before storing. A hot engine can be a fire hazard.
- **Storage location.** Store the log splitter in a location away from sources of heat, open flames, sparks or pilot lights – such as water heaters, space heaters, furnaces, clothes dryers, or other gas appliances. Even if the log splitter's gas tank is empty, residual gasoline vapors could ignite
- **Gasoline storage.** Store extra gasoline in a cool, dry place in an UL approved, tightly sealed container. Gasoline vapors can ignite if they collect inside an enclosure.
- **Periodic maintenance.** Perform periodic maintenance as directed in this manual to keep the log splitter in safe working condition.

This page has intentionally been left blank.



Manufactured by
Northern Tool + Equipment Co.,
2800 SouthCross Drive West
P.O. Box 1499 Burnsville, MN 55337-0499
Made in the USA