

KIT INSTRUCTIONS

KSP12-TD2 Ride-On Spreader Top Dressing Kit

Contact Us: 800.972.6130 | www.spyker.com



IMPORTANT: Please reference your spreader manual for information on the safety of persons and property. Read it carefully before assembly and operation of equipment!

Parts

Assembly

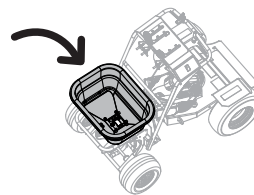
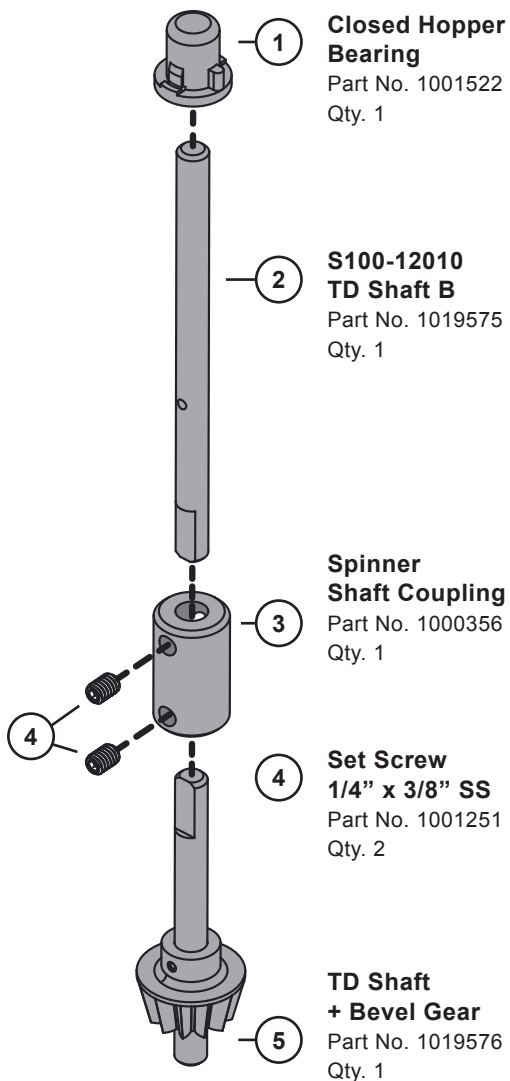

1. Remove the agitator (A) and felt washer (B).

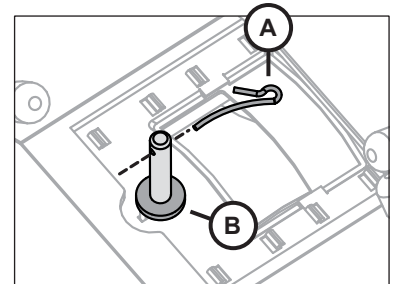

2. From the inside of the hopper using a flat head screwdriver, press bushing (C) out of hopper base.

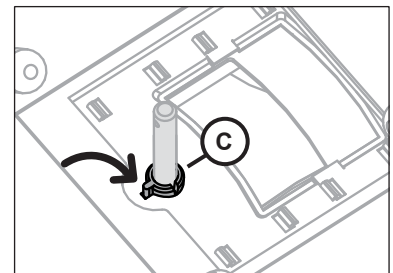

NOTE: Bushing will remain on shaft.

3. Remove the three screws (D) from the top of the transmission and lift off top cover (E).

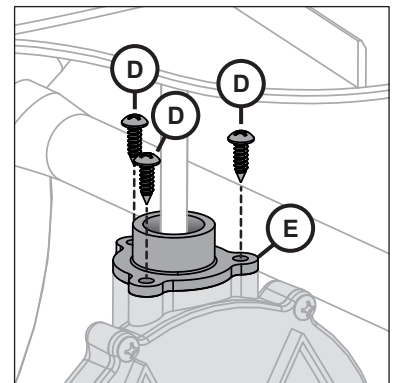
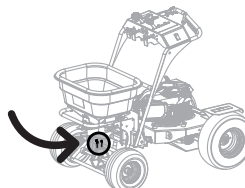

Assembly

- Remove the shaft (F) and fan (G) by rotating transmission (H) forward while pulling up on the shaft (F).

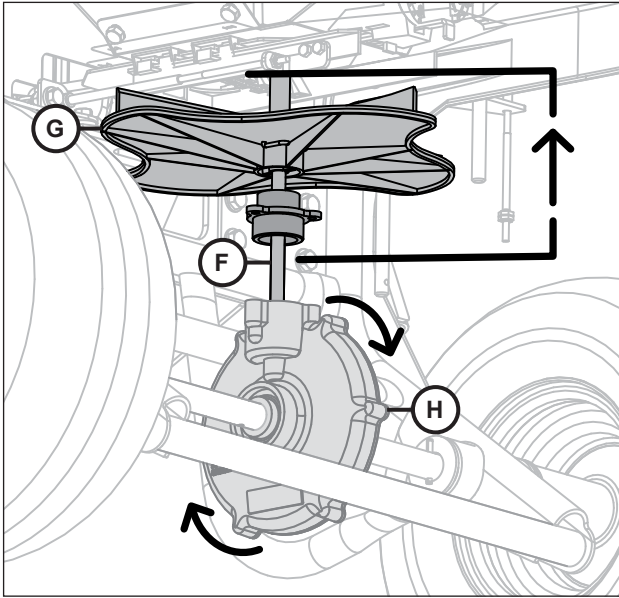

- Remove the clip and slide the fan (G) from the shaft (F). *NOTE: Retain fan and fan clip.*

6. Installing the Kit

Slide the transmission cover (E) over the new gear shaft assembly (5) as illustrated.

Insert the assembly (5) into the transmission gear box (H) and secure the transmission cover (E) with the original retained screws (D).

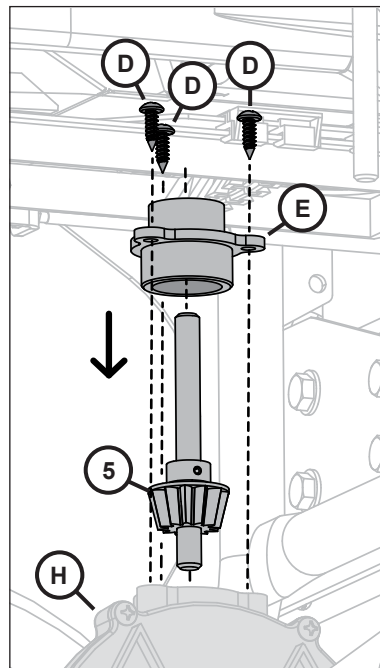

- Slide the spinner shaft coupling (3) on the shaft assembly (5).

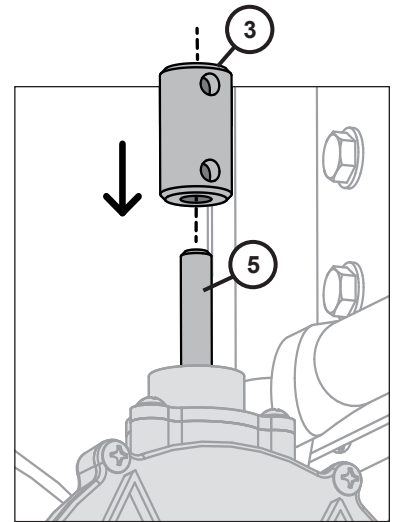

- Affix fan (G) to the new shaft (2), securing with the fan clip (J).

Add the closed hopper bearing (1) on top as illustrated here.

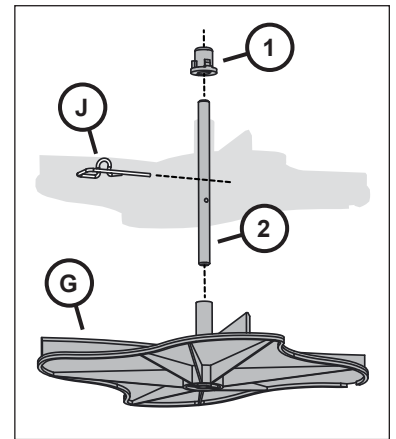

- FROM BELOW:** Find the opening at the center and base of the hopper. Press the closed hopper bearing (1) into the hopper base.

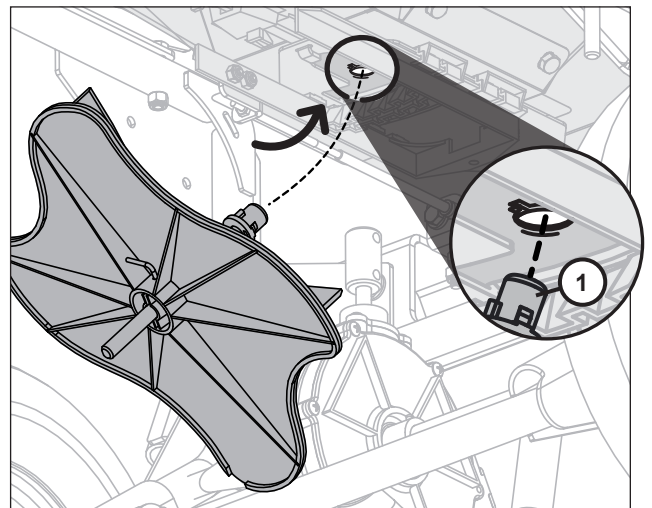

10. Install the base of the shaft (2) in the coupling (3) that was added on step 7. Secure with the two provided set screws (4).

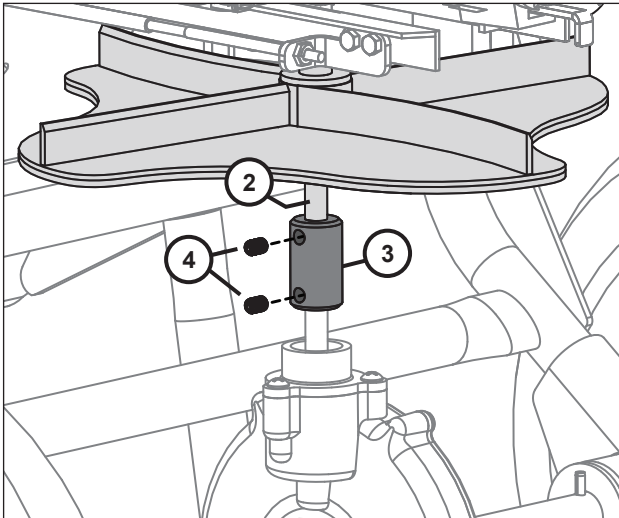

Assembly is complete.

SERVICE



*QUALITY CONTINUES
WITH QUALITY SERVICE*

If you have installation questions, are missing parts or need replacement parts, don't go back to the store!

Please find your product serial number and model number, then contact our Customer Service department:

 In North America and Canada call
Toll-Free: 800-972-6130

 Chat online: www.spyker.com

NOTES



WARRANTY

1 YEAR LIMITED WARRANTY

This is warranted to the original purchaser only. Spyker will replace parts with defects in materials and workmanship, for a period of one year from the date of purchase.

Spyker Spreaders will not be liable for any loss, damage or expense including, but not limited to, consequential or incidental damages, arising from the operation, condition or use of the item. The sole and exclusive remedy against Spyker Spreaders being the replacement of the defective parts. This warranty gives you specific legal rights, and you may also have other rights which vary from state to state.

This express warranty, which is applicable only to the original purchase, is in lieu of and excludes all other warranties, whether expressed or implied by operation of law or otherwise, including any warranty of merchantability or fitness for particular purpose.

SPYKER SPREADERS
Jeffersonville, IN 47130 USA
Phone: 800.972.6130
www.spyker.com