



Heavy-Duty Drywall Dolly Cart

Owner's Manual



⚠ WARNING: Read carefully and understand all ASSEMBLY AND OPERATION INSTRUCTIONS before operating. Failure to follow the safety rules and other basic safety precautions may result in serious personal injury.

Item #110132

SAVE THESE INSTRUCTIONS

Thank you very much for choosing a Strongway™ product!

For future reference, please complete the owner's record below:

Serial Number/Lot Date Code: _____

Purchase Date: _____

Save the receipt, warranty, and this manual. It is important that you read the entire manual to become familiar with this product before you begin using it.

This Heavy-Duty Drywall Dolly Cart is designed for certain applications only. Northern Tool and Equipment is not responsible for issues arising from modification or improper use of this product such as an application for which it was not designed. We strongly recommend that this product not be modified and/or used for any application other than that for which it was designed.

For technical questions, please call **1-800-222-5381**.

Table of Contents

Intended Use.....	4
Technical Specifications	4
Important Safety Information	4
Specific Operation Warnings	5
Assembly Instructions.....	5
Operating Instructions.....	7
Maintenance	8
Parts Diagram.....	8
Parts List.....	8
Replacement Parts	9
Limited Warranty	10

Intended Use

This Strongway Heavy-Duty Drywall Dolly Cart is made from welded 1inch steel tubing for durability. The stepped 14-gauge steel plate bed provides stability for 8 inch rubber casters (2 rigid and 2 swivel). Overall dimensions are 49 ^{5/8} inches (L) x 22 ^{3/4} inches (W) x 46 1/2 inches (H). Deck with cross braces attaches to upright frame to help keep load in place.

Technical Specifications

Property	Specification
Total Capacity (lbs.)	1,600
Support Arm (qty.)	1
Platform Size (in.)	47.48 (L) x 22.83 (W) x 46.26 (H)
Ship Weight (lbs.)	64

Important Safety Information

⚠WARNING

- Read and understand all instructions. Failure to follow all instructions may result in serious injury or property damage.
- The warnings, cautions, and instructions in this manual cannot cover all possible conditions or situations that could occur. Exercise common sense and caution when using this cart. Always be aware of the environment and ensure that the cart is used in a safe and responsible manner.
- Do not allow persons to operate or assemble the product until they have read this manual and have developed a thorough understanding of how it works.
- Do not modify this cart in any way. Unauthorized modification may impair the function and/or safety and could affect the life of the cart. There are specific applications for which the product was designed.
- Use the right tool for the job. DO NOT attempt to force small equipment to do the work of larger industrial equipment. There are certain applications for which this equipment was designed. It will be safer and do a better job at the capacity for which it was intended. DO NOT use this equipment for a purpose for which it was not intended.
- Industrial or commercial applications must follow OSHA requirements.

⚠WARNING

This product may contain chemicals known to the State of California to cause cancer, birth defects or other reproductive harm.

⚠WARNING

WORK AREA SAFETY

- Inspect the work area before each use. Keep work area clean, dry, free of clutter, and well-lit. Cluttered, wet, or dark work areas can result in injury. Using the cart in confined work areas may put you dangerously close to cutting tools and rotating parts.

- Keep children and bystanders away from the work area while operating the cart. Do not allow children to handle the cart.

⚠WARNING

PERSONAL SAFETY

- Stay alert, watch what you are doing, and use common sense when operating the cart. Do not use the cart while you are tired or under the influence of drugs, alcohol, or medication. A moment of inattention while operating the cart may result in serious personal injury.
- Dress properly. Do not wear loose clothing, dangling objects, or jewelry. Keep your hair, clothing and gloves away from moving parts. Loose clothes, jewelry, or long hair can be caught in moving parts. Air vents on the tool often cover moving parts and should be avoided.
- Wear the proper personal protective equipment when necessary. Use ANSI Z87.1 compliant safety goggles (not safety glasses) with side shields, or when needed, a face shield. Use a dust mask in dusty work conditions. Also use non-skid safety shoes, hardhat, gloves, dust collection systems, and hearing protection when appropriate. This applies to all persons in the work area.
- Do not overreach. Keep proper footing and balance at all times.

⚠CAUTION

CART USE AND CARE

- Do not force the cart. Products are safer to use and do a better job when used in the manner for which they are designed. Plan your work, and use the correct product for the job.
- Check for damaged parts before each use. Carefully check that the cart will operate properly and perform its intended function. Replace damaged or worn parts immediately. Never operate the cart with a damaged part.
- Store the cart when it is not in use. Store it in a dry, secure place out of the reach of children. Inspect the tool for good working condition prior to storage and before re-use.
- Use only accessories that are recommended by the manufacturer for use with your cart. Accessories that may be suitable for one product may create a risk of injury when used with another tool. Never use an accessory that has a lower operating speed or operating pressure than the tool itself.

Specific Operation Warnings

⚠WARNING

- Do not exceed the rated load capacity.
- Do not use to transport people or animals.

Assembly Instructions

Step 1

Assemble swivel casters(#6) and rigid casters(#7) to the platform(#1) with M10 bolts(#8)、M10 nuts(#9) and M10 flat(#10)/spring washers(#11).

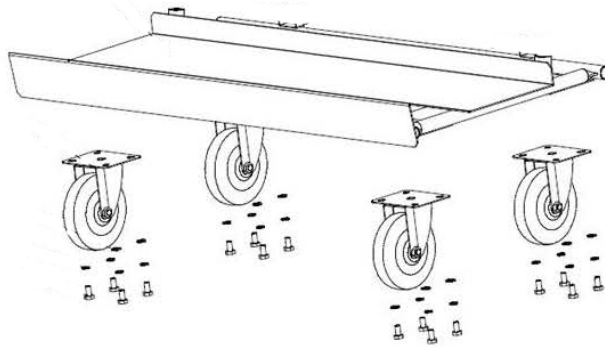

Figure 1

Step 2

Connect Elbow 1 with handle holder(#2)、Support Tube(#3)、Elbow 2(#4) and Connecting Tube(#5) with M8 bolts(#12)、M8 nuts(#13) and M8 flat washers(#14).

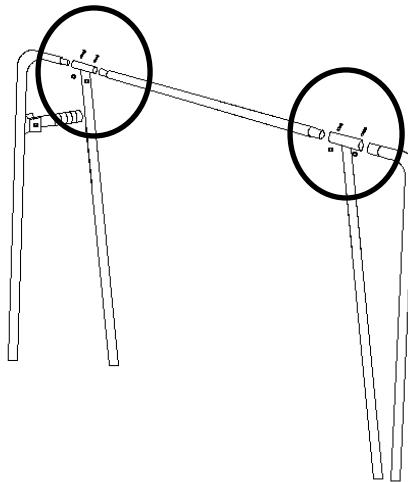

Figure 2

Step 3

Insert the handle assembly into the holes on the platform (#1), and secure with M8 bolts(#12)、M8 nuts(#13) and M8 flat washers(#14).

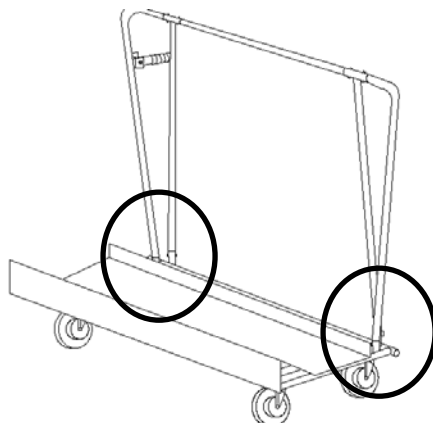

Figure 3

Make sure all hardware is tightened, then the drywall cart is ready for your use.



Operating Instructions

1: Place the drywall dolly on the floor evenly.



2: Put the object onto the middle of the body of the drywall cart, and then push the frame slightly.



Maintenance

Maintain the product by adopting a program of conscientious repair and maintenance in accordance with the following recommended procedures. It is recommended that the general condition of any tool be examined before it is used. Keep your tool in good repair. Keep all cutting tools sharp and clean. Properly maintained cutting tools with sharp cutting edges are less likely to bind and are easier to control. Keep handles dry, clean, and free from oil and grease. Also refer to the engine manufacturer's instruction manual for additional information about engine maintenance. The following chart is based on a normal operation schedule.

Maintenance Interval	Maintenance Point
Daily before operating	Check all the hardware, Tighten as required. Keep cart clean.

Parts Diagram

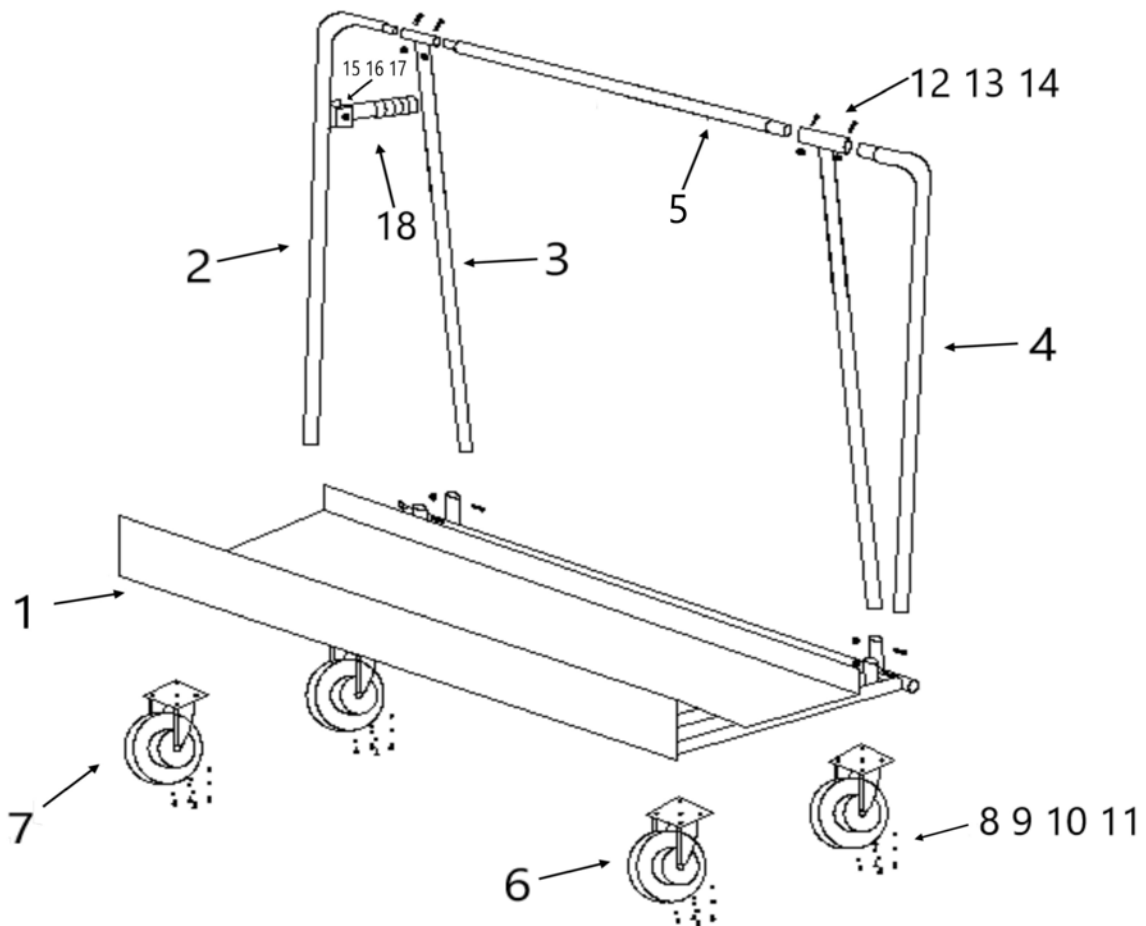

Parts List

Reference	Part Number	Part Description	Quantity
1	1	Platform	1
2	2	Elbow 1 with handle holder	1
3	3	Support Tube	2

Reference	Part Number	Part Description	Quantity
4	4	Elbow 2	1
5	5	Connecting Tube	1
6	6	Swivel Caster	2
7	7	Rigid Caster	2
8	8	M10 Bolt	16
9	9	M10 Nut	16
10	10	M10 Flat Washer	16
11	11	M10 Spring Washer	16
12	12	M8 Bolt	8
13	13	M8 Nut	8
14	14	M8 Flat Washer	8
15	15	M10 Bolt	1
16	16	M10 Nut	1
17	17	M10 Flat Washer	2
18	18	Handle	1

Replacement Parts

- For replacement parts and technical questions, please call Customer Service at **1-800-222-5381**.
- Not all product components are available for replacement. The illustrations provided are a convenient reference to the location and position of parts in the assembly sequence.
- When ordering parts, the following information will be required: item description, item model number, item serial number/item lot date code, and the replacement part reference number.
- The distributor reserves the rights to make design changes and or improvements to product lines and manuals without notice.

Limited Warranty

Northern Tool and Equipment Company, Inc. ("We" or "Us") warrants to the original purchaser only ("You" or "Your") that the Strongway product purchased will be free from material defects in both materials and workmanship, normal wear and tear excepted, for a period of one year from date of purchase. The foregoing warranty is valid only if the installation and use of the product is strictly in accordance with product instructions. There are no other warranties, express or implied, including the warranty of merchantability or fitness for a particular purpose. If the product does not comply with this limited warranty, Your sole and exclusive remedy is that We will, at our sole option and within a commercially reasonable time, either replace the product or product component without charge to You or refund the purchase price (less shipping). This limited warranty is not transferable.

Limitations on the Warranty

This limited warranty does not cover: (a) normal wear and tear; (b) damage through abuse, neglect, misuse, or as a result of any accident or in any other manner; (c) damage from misapplication, overloading, or improper installation; (d) improper maintenance and repair; and (e) product alteration in any manner by anyone other than Us, with the sole exception of alterations made pursuant to product instructions and in a workmanlike manner.

Obligations of Purchaser

You must retain Your product purchase receipt to verify date of purchase and that You are the original purchaser. To make a warranty claim, contact Us at 1-800-222-5381, identify the product by make and model number, and follow the claim instructions that will be provided. The product and the purchase receipt must be provided to Us in order to process Your warranty claim. Any returned product that is replaced or refunded by Us becomes our property. You will be responsible for return shipping costs or costs related to Your return visit to a retail store.

Remedy Limits

Product replacement or a refund of the purchase price is Your sole remedy under this limited warranty or any other warranty related to the product. We shall not be liable for: service or labor charges or damage to Your property incurred in removing or replacing the product; any damages, including, without limitation, damages to tangible personal property or personal injury, related to Your improper use, installation, or maintenance of the product or product component; or any indirect, incidental or consequential damages of any kind for any reason.

Assumption of Risk

You acknowledge and agree that any use of the product for any purpose other than the specified use(s) stated in the product instructions is at Your own risk.

Governing Law

This limited warranty gives You specific legal rights, and You also may have other rights which vary from state to state. Some states do not allow limitations or exclusions on implied warranties or incidental or consequential damages, so the above limitations may not apply to You. This limited warranty is governed by the laws of the State of Minnesota, without regard to rules pertaining to conflicts of law. The state courts located in Dakota County, Minnesota shall have exclusive jurisdiction for any disputes relating to this warranty.



Distributed by:

Northern Tool & Equipment Company, Inc.

Burnsville, Minnesota 55306

www.northerntool.com

Made in Vietnam