

Please read and save this Repair Parts Manual. Read this manual and the General Operating Instructions carefully before attempting to assemble, install, operate or maintain the product described. Protect yourself and others by observing all safety information. The Safety Instructions are contained in the General Operating Instructions. Failure to comply with the safety instructions accompanying this product could result in personal injury and/or property damage! Retain instructions for future reference. AMT reserves the right to discontinue any model or change specifications at any time without incurring any obligation.

©2006 American Machine & Tool Co., Inc. of PA, A Subsidiary of The Gorman-Rupp Company, All Rights Reserved.

▲ WARNING Periodic maintenance and inspection is required on all pumps to insure proper operation. Unit must be clear of debris and sediment. Inspect for leaks and loose bolts. Failure to do so voids warranty.

SELF-PRIMING SPRINKLER/BOOSTER PUMPS

Refer to pump manual 1808-634-00 for General Operating and Safety Instructions.

Description

These self-priming (to 20 ft. lift) lawn sprinkler pumps are equipped with a check valve to assist in positive priming, a high performance closed impeller, a Buna-N mechanical seal to prevent leakage, and a continuous duty motor.

Pumps are designed for higher pressure applications such as lawn sprinkling, spraying irrigation, also draining and general de-watering applications. Casing working pressure to 150 psi (1034 kPa). Handles fluids from 40° to 180° F (4° to 82° C). For use with nonflammable, non-abrasive liquids compatible with pump component materials.

Maintenance

▲ WARNING

Make certain that this unit is disconnected from

power source before attempting to service or remove any component!

MECHANICAL SEAL REPLACEMENT

Refer to Seal Replacement figures 2, 3.

IMPORTANT: Always replace both seal seat (Ref. No. 6) and seal head (Ref. No. 7) to insure proper mating of components! Also, impeller seal (Ref. No. 22) (where applicable) should be replaced anytime impeller fastener (Ref. No. 23) has been removed.

1. Unthread fasteners (Ref. No. 16) and remove pump casing (Ref. No. 14), casing seal (Ref. No. 5), and flapper valve (Ref. No. 13) from adapter (Ref. No. 4).
2. Unthread fasteners (Ref. Nos. 12 and 17) and remove volute (Ref. No. 10) from adapter.
3. Remove impeller fastener, impeller seal (where applicable), and impeller (Ref. No. 9).
4. Shaft sleeve (Ref. No. 21) (where applicable) and seal head can now be pulled from shaft.

IMPORTANT: Care should be taken to insure that the same number of shim washers (Ref. No. 8) are replaced behind impeller as were removed. These shim washers are located directly behind impeller. These washers as well as impeller key (Ref. No. 24) (where applicable) become loose as impeller is removed.

NOTE: Some motors (Ref. No. 20) use an open end 7/16" wrench across flats on rear of motor shaft (remove bearing cap for access) to prevent shaft from turning. Other

motor shafts have a screwdriver slot instead of flats.

5. Unscrew fasteners (Ref. No. 23). Remove mounting base and handle (Ref. No. 18 & 2) (where applicable), and adapter from motor mounting face.
6. Push seal seat from back of adapter recess with a screwdriver.
7. Clean adapter recess before inserting a new seal seat.

▲ CAUTION *The precision lapped faces on mechanical seal are easily damaged.*

Handle your replacement seal carefully.

8. Carefully wipe polished surface of new seal seat with a clean cloth.
9. Wet rubber portion of seal seat with a light coating of soapy water.
10. Press new seal seat squarely into recess in adapter. If seal seat does not press squarely into cavity, it can be adjusted in place by pushing on it with a piece of pipe. Always use a piece of cardboard between pipe and seal seat to avoid scratching polished surface.
11. After seal seat is in place, ensure that it is clean and has not been marred.

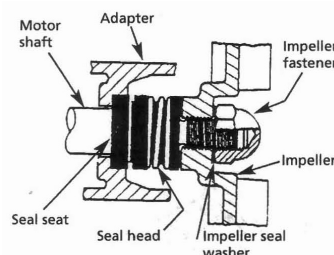

Figure 2 - Mechanical Seal Replacement for Threaded Shaft (379 Series).

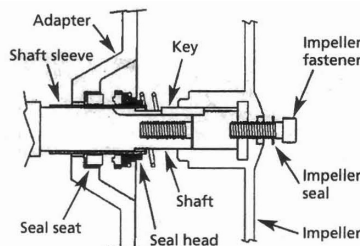

Figure 3 - Mechanical Seal Replacement for Keyed Shaft (365 Series).

NOTE: If removed, slide slinger washer (Ref. No. 1) onto shaft until it is located approximately 1/8" from face of motor bearing hub.

12. Using a clean cloth, wipe shaft/shaft sleeve and make certain that it is perfectly clean.
13. Secure foot and handle (where applicable) and adapter on motor mounting face. Carefully guide motor shaft through seal seat.
14. Replace shaft sleeve and impeller key (where applicable).

IMPORTANT: Before installing new shaft sleeve, apply a bead of non-hardening, pliable sealant (such as Permatex® Form-A-Gasket® No. 2) to motor shaft shoulder.

15. Wet inside rubber portion of new seal head with a light coating of soapy water. Slide head onto shaft/shaft sleeve. Seal head and seal seat will meet. Reinstall any shims which have been removed. (See Shim Adjustment).
16. Install impeller and reassemble pump.
17. A short "run-in" period may be necessary to provide completely leak-free seal operation.

SHIM ADJUSTMENT (365 SERIES ONLY)

When installing a replacement impeller (Ref. No. 9) or motor (Ref. No. 20), it may be necessary to adjust number of shims (Ref. No. 8) to insure proper running clearance between impeller and volute (Ref. No. 10). Proceed as follows:

NOTE: A proper running clearance is less than 0.010" (face of impeller to mating face of volute).

1. For impeller replacement, add one (0.010") shim in addition to those removed originally.
2. For motor replacement, add two (0.010") shims in addition to those removed during disassembly.
3. Reassemble the pump as described in steps 16 and 17 (above).

IMPORTANT: Ensure that volute is snugly in place and check shaft to make sure it is turning freely (use 7/16" wrench or screwdriver to turn shaft). If it turns freely, check to ensure that adapter (Ref. No. 4) and volute are fitted metal-to-metal where they meet on outside. If they are not metal-to-metal, tighten fasteners (Ref. No. 12 & 17) and recheck shaft for free turning. Tighten carefully, turning shaft while tightening so that motor bearings are not damaged in the event that too many shims were installed. If shaft seizes before fasteners are completely tight, disassemble pump and remove one (0.010") shim and repeat reassembly.

4. When proper clearance is obtained, reassemble.

Please provide following information:

- Model number
- Serial number (if any)
- Part descriptions and number as shown in parts list

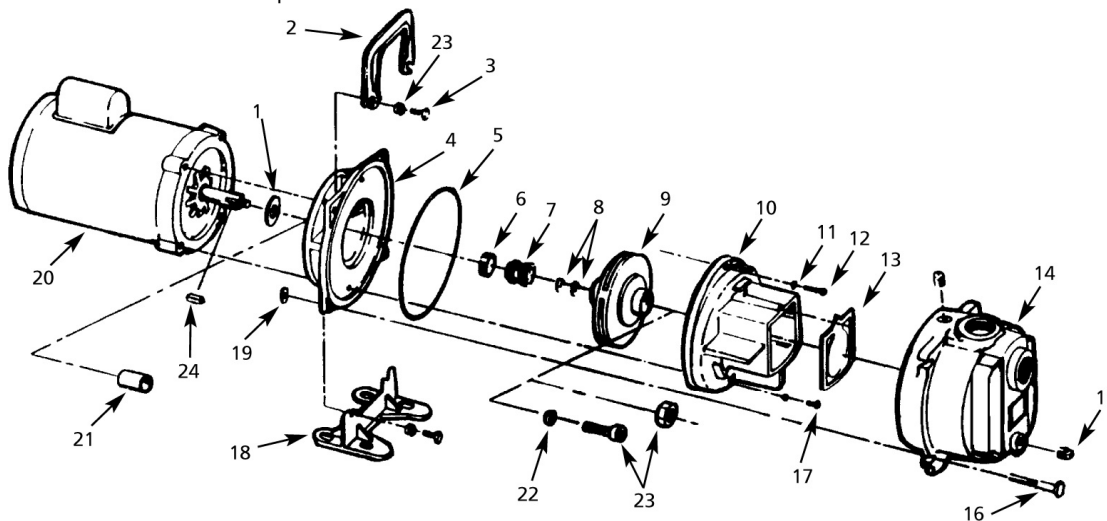

Repair Parts List

Ref. No.	Description	3790 (3/4 HP)	3791 (1 HP)	3792 (1½ HP)	3793 (2 HP)			Qty.
		379G (3/4 HP)	379H (1 HP)	3797 (1½ HP)	379K (2 HP)	3657 (5 HP)	3656 (7½ HP)	
		379A (1 HP)	379B (1½ HP)	379C (2 HP)	379D (3 HP)	3655 (5 HP)	3656 (7½ HP)	
		379F (1 HP)	379J (1½ HP)	379E (2 HP)	379L (3 HP)	3655 (5 HP)	3656 (7½ HP)	
1	Slinger washer	1534-000-00	1534-000-00	1534-000-00	1534-000-00	1470-093-00	1470-093-00	1
2	Handle	1515-000-00	1515-000-00	1515-000-00	1515-000-00	--	--	1
3	Fastener	*	*	*	*	*	*	4
4	Adapter	1608-011-01	1608-011-01	1608-011-01	1608-011-01	3655-030-09	3655-030-09	1
5	Casing Seal - Buna N (std)	1610-000-00	1610-000-00	1610-000-00	1610-000-00	2186-000-00	2186-000-00	1
	- Viton (opt)	1610-001-00	1610-001-00	1610-001-00	1610-001-00	2186-001-00	2186-001-00	
6 & 7	† Shaft seal assy. -Buna N (std)	1640-161-96	1640-161-96	1640-161-96	1640-161-96	1640-163-90	1640-163-90	1
	† - Viton (opt)	1640-161-97	1640-161-97	1640-161-97	1640-161-97	1640-163-91	1640-163-91	
8	Impeller Shim pkg.	--	--	--	--	1664-000-90	1664-000-90	1
9	Impeller	379A-011-09	379B-011-09	379C-011-09	379D-011-09	3655-012-09	3656-012-09	1
10	Volute	379B-150-09	379B-150-09	379D-150-09	379D-150-09	3655-150-09	3655-150-09	1
11	Washer	*	*	*	*	*	*	2
12	Fastener	*	*	*	*	*	*	2
13	Flapper valve -Buna N (std)	1609-002-00	1609-002-00	1609-002-00	1609-002-00	1609-002-00	1609-002-00	1
	-Viton (opt)	1695-011-90	1695-011-90	1695-011-90	1695-011-90	1695-011-90	1695-011-90	
14	Casing	2111-001-01	2111-001-01	2111-001-01	2111-001-01	2112-001-02	2112-001-02	1
15	Pipe plug	*	*	*	*	*	*	2
16	Fastener	*	*	*	*	*	*	4
17	Fastener	*	*	*	*	*	*	1
18	Foot	1506-000-00	1506-000-00	1506-000-00	1506-000-00	--	--	1
19	Fastener	*	*	*	*	*	*	1
20	Motor - 1 Phase ODP	1626-010-00	1626-011-00	1626-012-00	1626-024-00	--	--	1
	- 3 Phase ODP	1626-014-00	1626-015-00	1626-016-00	1626-025-00	--	--	
	- 1 Phase TEFC	1626-069-00	1626-050-00	1626-070-00	1626-071-00	1626-078-00	--	
	- 3 Phase TEFC	1626-077-00	1626-053-00	1626-054-00	1626-072-00	1626-044-00	1626-045-00	
21	Shaft sleeve	--	--	--	--	1472-000-00	1472-000-00	1
22	Impeller seal	--	--	--	--	1471-020-00	1471-020-00	1
23	Impeller fastener	1784-001-09	1784-001-00	1784-001-00	1784-001-00	1756-000-00	1756-000-00	1
24	Impeller key	--	--	--	--	1471-030-00	1471-030-00	1

(*) Standard hardware item, available locally

(†) Seal head (Ref. No. 7) and seat (Ref. No. 6) available as a set only. When replacing a shaft seal assembly, a new impeller seal (Ref. No. 23) should also be used. (Model series 365 only).