

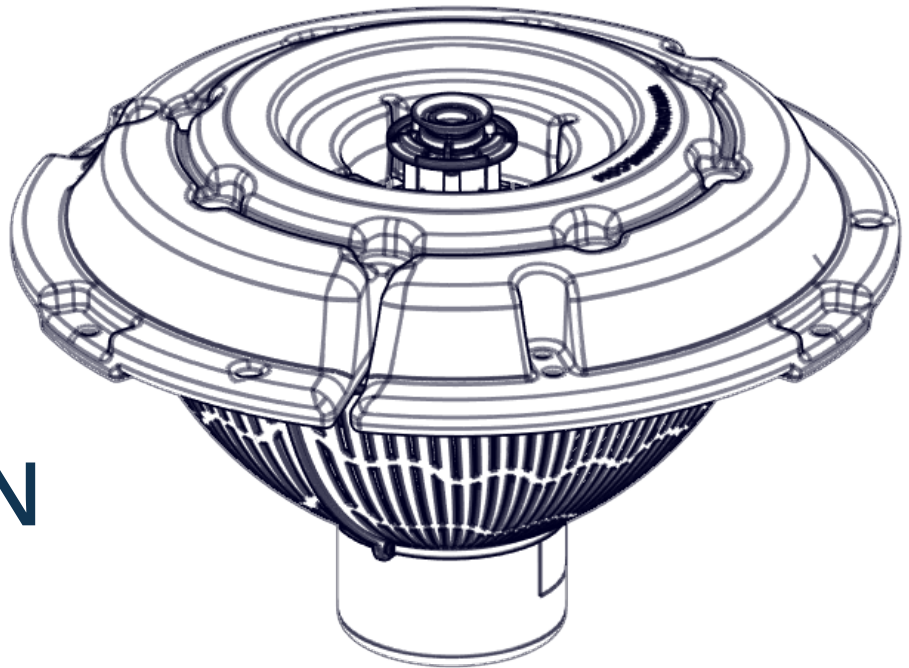

MOVING WATER FORWARD, SINCE 1968



J SERIES FOUNTAIN

3400, 4400

Operation & Maintenance Manual



3020379
us ANSI/UL 778: 2016
Ed.6+R:22Feb2017
Intertek CSA C22.2 #108: 2014 Ed.5

Document number 884180

Document version 2021.2.0

800 Deere Rd. Prescott, WI 54021 | 715.262.4488 | sales@kascomarine.com | kascomarine.com

TABLE OF CONTENTS

Safety First.....	2
General Instructions.....	3
Unit Specifications & Pattern Size	4
Parts Included	5
Included Nozzles.....	8
Unit Installation Instructions	9
Replacement Parts	10
Maintenance Recommendations.....	11
Troubleshooting Tips.....	12
Warranty	13
Non-Warranty Repairs	14
Repair Contact Form	15

QUESTIONS?



715.262.4488



kascomarine.com | sales@kascomarine.com

SAFETY FIRST

IMPORTANT: PLEASE READ THIS MANUAL AND SAVE FOR FUTURE REFERENCE

WARNINGS:



Moving Machinery



Shock Hazard

- Please read and follow these important instructions to help ensure your safety and the quality performance of your Kasco equipment.
- Use caution when dealing with any electrical and/or moving equipment.
- Under NO CIRCUMSTANCE should anyone enter the water with the electrical equipment plugged in and/or in operation.
- Kasco Aerating Fountains are intended for use with a Listed control panel having a GFCI protected receptacle, or field wiring terminals and disconnect switch, or a timer with a disconnect for use with a GFCI receptacle. Control panels MUST be installed by a qualified electrician. Ground Fault Circuit Interrupters (GFCIs) should be tested upon each installation and every month thereafter to ensure proper operation.
- Single-phase units are supplied with an internal grounding conductor and/or a grounding-type attachment plug. To reduce the risk of electrical shock, be certain the unit is properly connected to the Kasco-supplied control panel (refer to the instructions included with your control panel).
- NEVER run the unit out of the water. This will damage the seals and create a dangerous situation for the operator.
- Use extreme caution around water, especially cold water, as in spring, fall, and winter, which poses a hazard in and of itself.
- NEVER lift or drag the equipment by the power cords. If you need to pull the unit to the side of the pond, use the anchoring ropes.
- Do not use boats that tip easily for installation and follow all boating safety rules and regulations, including wearing a PFD (Personal Flotation Device).
- Do not use waders in deep ponds/lakes or ponds/lakes with drop-offs, drastic slopes, or soft bottom material.
- Control panels must be installed by a qualified electrician.
- Ground Fault Circuit Interrupters (GFCI) should be tested upon each installation and every month thereafter to ensure proper operation.
- For more information regarding your control panel instructions, refer to your control panel owner's manual. A control panel must be installed a minimum of 5 feet (3m in Canada) from the body of water unless separated from the body of water by a fence, wall, or other permanent barrier that will make the unit inaccessible to persons in the water. A complete list of control panels can be found in the Accessories section of kascomarine.com.



During flotation operation, water is pulled from 360° around and directly below the unit. Keep these areas clear of debris as much as possible to decrease frequency of screen cleaning.

GENERAL INSTRUCTIONS

Inspect the Shipment

Immediately inspect your Kasco fountain shipment for any visible damages. Also cross reference the parts supplied with the Parts Included sheet to check for shortages. Shortages should be reported immediately to your Kasco Marine distributor or representative and damages reported to your carrier and Kasco Marine.

Assembly & Installation

Please see the proper Assembly and Installation Instructions enclosed in this manual. Each is specific for your model and size of fountain.

- Use a nylon tie to help keep the power cords for the unit and lights free of the propeller by tying each cord to either side of the float. If you have a light kit, make sure that the unit cord is tied to one side of the float and the light cord to the other for balance.
- It is extremely important to test the GFCI breaker in the control panel upon each installation/re-installation of the unit to ensure proper functioning.

Use & Operation

Kasco fountains are designed and engineered for continuous duty, such as on fish farms or other aquaculture applications, or on-demand use, as needed in a recreational water feature. During flotation operation, the water is pulled from 360 degrees around the unit and from below the unit. The water is pulled upward and thrust through the flotation collar into the air.

Your Kasco Marine fountain is ready for immediate use (after installation). The motor and ball bearings are submerged in oil, and no further lubrication is needed. Make sure to keep the motor housing clean from hard water deposits and/or algae. (See Maintenance Recommendations.)

It is extremely important that proper and sufficient voltage (120V or 240/208V) is supplied to the Fountain motor. Each 120V Fountain is supplied with a UL and CSA approved C-25 GFCI Protected Control Box. The Fountain is to be plugged into the C-25 outlet labeled "UNIT" and the C-25 plugged into a properly grounded receptacle. Each 240V Fountain is supplied with a UL and CSA approved C-85 GFCB Protected Control Panel. The Fountain is to be hardwired into C-85 panel. The C-85 must have 4 wire service (L1, L2, neutral, and ground) installed by a qualified electrician. It is extremely important to test the GFCI breaker in the control panel upon each installation and re-installation and every month thereafter to ensure proper operation. (See Control Panel Instructions.)

UNIT SPECIFICATIONS & PATTERN SIZE

Model	Voltage	Operating Amps	Locked Rotor Amps	Control Panel Connection	Unit Connection
Single-Phase Units					
3400JF	110-120	7.3	18	C-25 plug in	Plug into C-25
3400HJF	208-240	3.7	9	Hardwire C-85	Plug into or hardwire C-85
4400JF	110-120	11	40	C-25 plug in	Plug into C-25
4400HJF	208-240	5.5	20	Hardwire C-85	Plug into or hardwire C-85

	Cord Gauge				
	50 ft.	100 ft.	150 ft.	200 ft.	250 - 400 ft.
3400JF	16	14	12	12	N/A
3400HJF / 4400HJF	14	14	12	12	12
4400JF	14	12	10	10	N/A

PARTS INCLUDED

ID	Description	Qty	Part #
1	Fountain	1	N/A
2	Float	1	242001
3	1/4-20 x 4" Phillips Pan Head Screw	4	251220
4	1/4" split washers	7	840537
5	1/4" (3/4" OD) Flat Washer	10	251300
6	1/4 -20 x 1-3/4" Hex Head Bolt	3	475630
7	Bottom Screen Section	3	361540
8	1/4"-20 Nut	3	840536
9	#8 nut	6	771034
10	#8 flat washer	12	361543
11	#8 lock washer	6	771033
12	#8 x 3/4" screw	6	361545
13	Mooring ropes (not pictured)	2	990700
14	Cable ties (not pictured)	9	415038

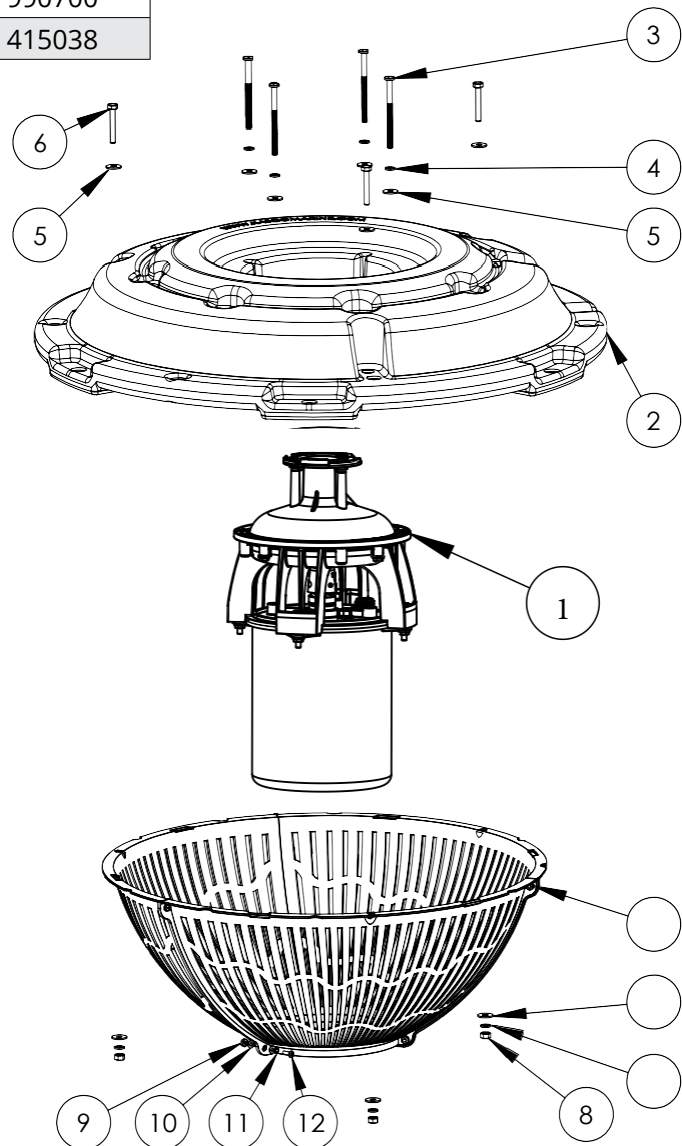

ASSEMBLY INSTRUCTIONS

1. Rest the float on the 4 legs of the housing

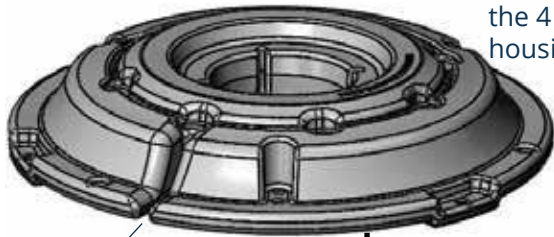

Align power cord with notch

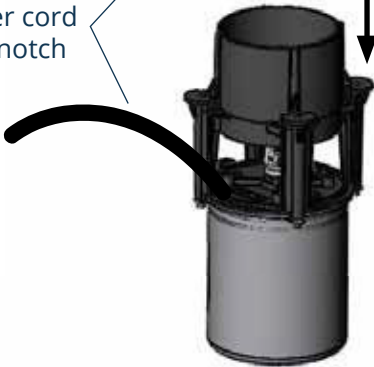

Align bolt holes with legs.

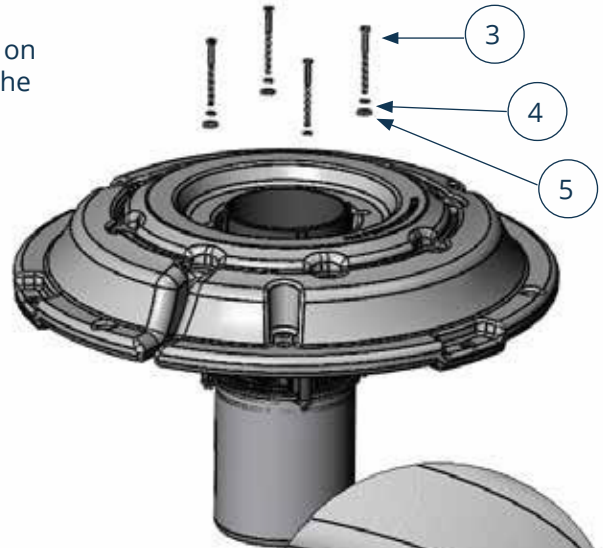

2. Lock washer goes between bolt and flat washer. Tighten down in 4 places.

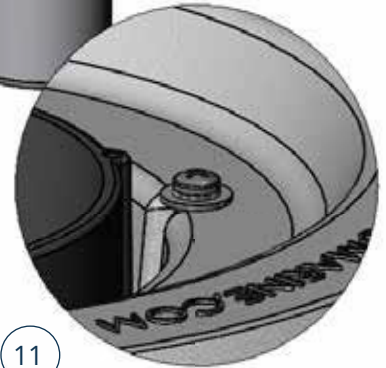

3. Turn over. Bring bottom screen sections together.

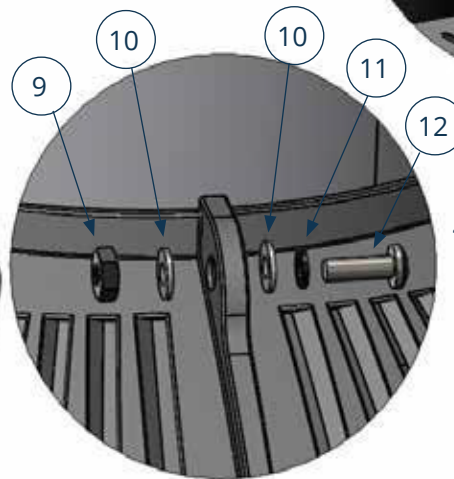
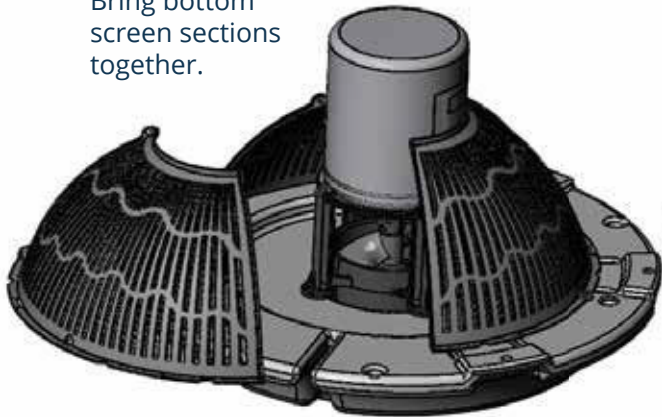

4. Tighten down in 6 places to hold the screen together.

5. Secure the bottom screen to the float in 3 places.

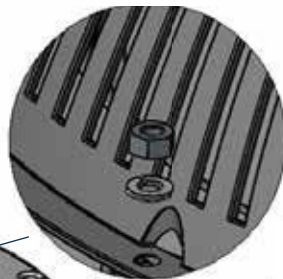
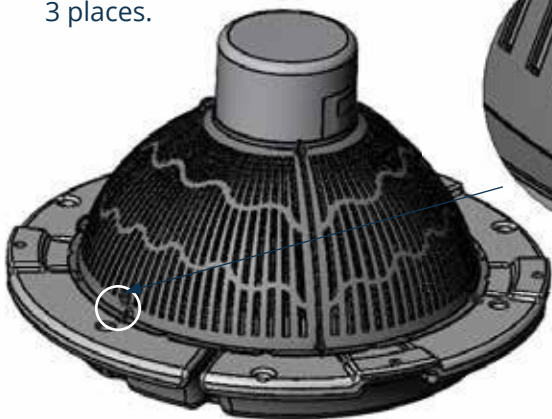

Make sure cord is sticking out of notch.

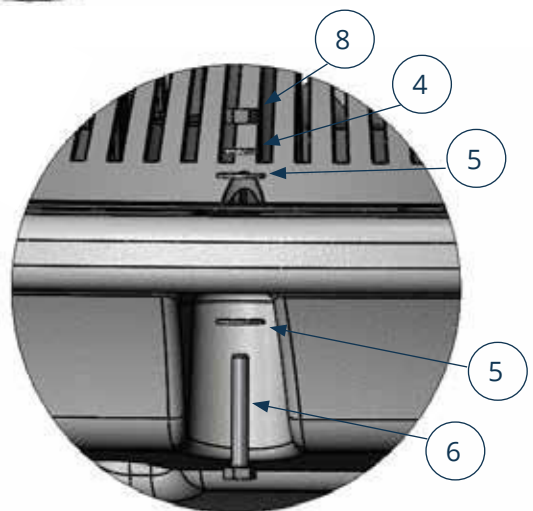

ASSEMBLY INSTRUCTIONS (CONT.)

6. Turn upright. Secure power cord to rope hole.

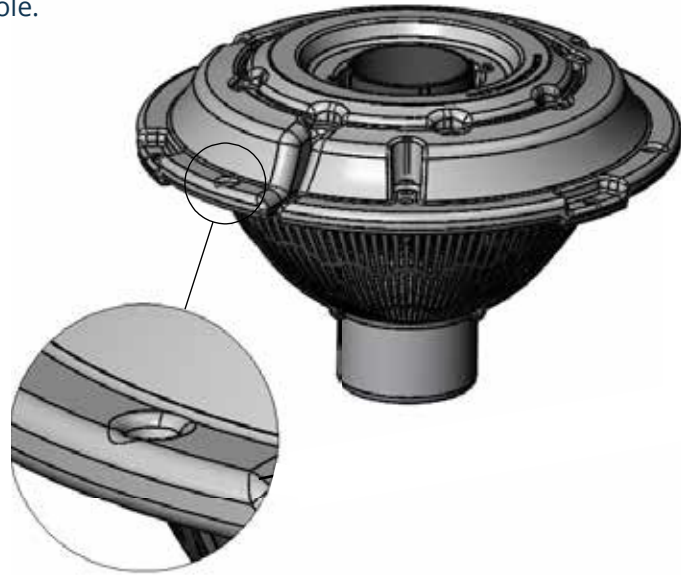

Cord Strain Relief

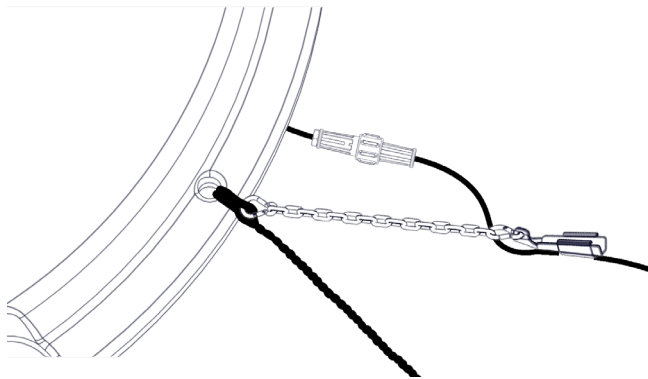

Providing strain relief on the cord helps ensure that its weight and any strain placed on it in the water will not cause the float to tilt or cause damage to the unit.

If your Kasco cord comes with a strain relief kit attached, attach the available link to the float-side knot in the mooring rope, as pictured here.

7. Choose Nozzle. Push nozzle into cone and twist to lock the 3 tabs into the nozzle plate.

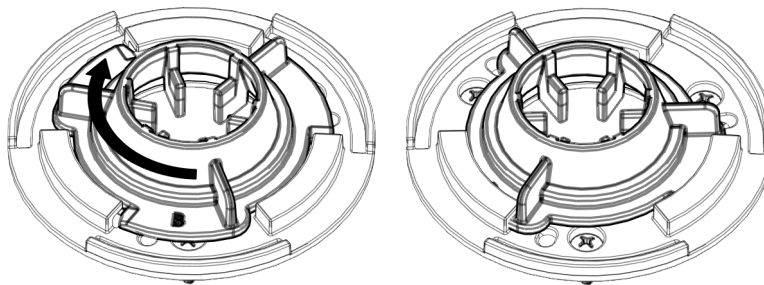

INCLUDED NOZZLES

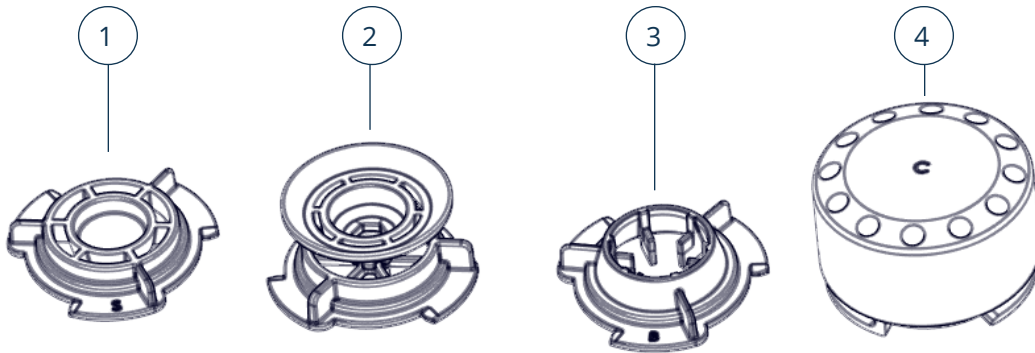

ID	Pattern	Description	Model	Height	Width	Part No.
1	Sequoia	Narrow geyser, marked S. (Pre-installed)	3400	13'	8'	431230
			4400	18'	11'	
2	Linden	Center geyser with lower conical pattern, 2-piece assembly with bolt.	3400	9'	29'	431232
			4400	12'	31'	
3	Birch	Wide geyser, marked B.	3400	7'	5'	431234
			4400	11'	8'	
4	Cypress	1 tier of 12 arcing streams, marked C.	3400	7'	17'	431236
			4400	9'	28'	
5	Willow	Wide arc, no nozzle installed.	3400	6.5'	21'	N/A
			4400	9'	31'	

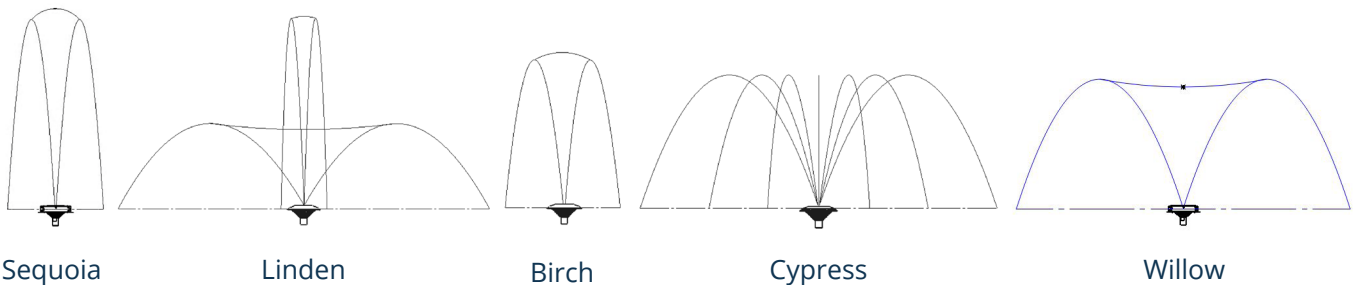

NOTE  Pattern sizes listed are approximate. Variations in voltage caused by regional electrical differences or voltage drop due to long power cords may result in reduced pattern sizes.

To install, place o-ring around outlet and simply twist the nozzle into the 3 locking tabs.

UNIT INSTALLATION INSTRUCTIONS

Use ropes to position the fountain in the desired location in the pond or lake. Anchor the ropes or secure them to the shoreline so that they are free of slack, but not tight. To prevent twisting of the unit due to motor torque, place the anchor at least 3 feet from the float for each foot of depth (Ex. a 6 ft. deep pond would require an anchor 18 ft. horizontally from the float).

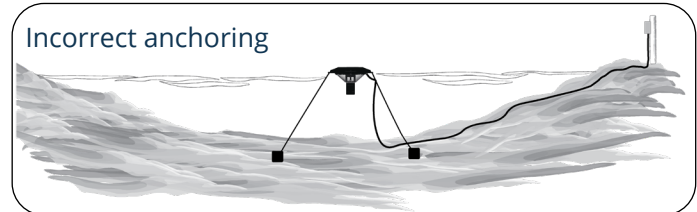
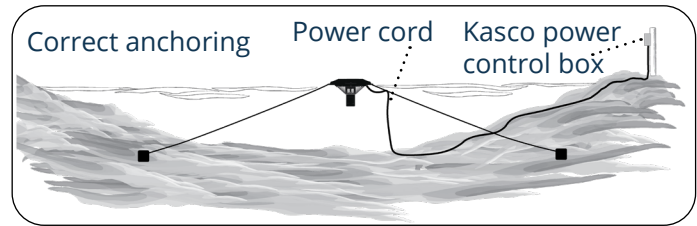

Alternate Installation

In ponds where the water level fluctuates significantly, a small weight may need to be suspended at the midpoint of the rope to take up any slack caused by a drop in water level (1 foot of 1" galvanized pipe works well). The weight should be light enough so that the fountain can rise as the water level rises. This weight can also help hide the anchoring ropes by sinking them further below the surface.

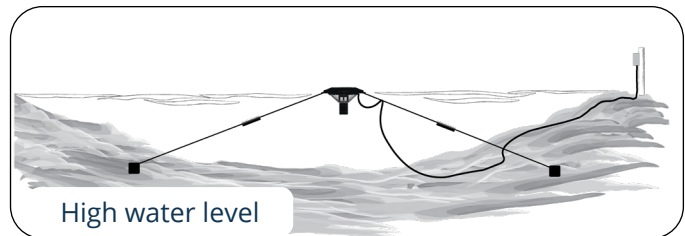
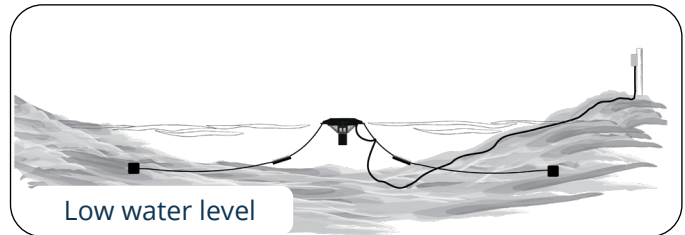
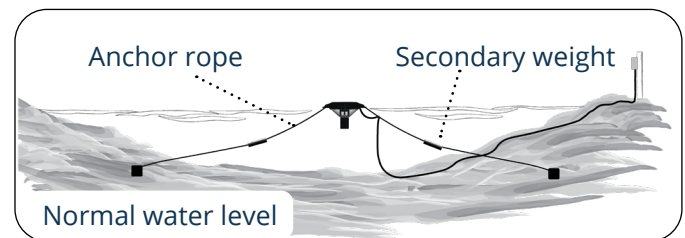

After unit is installed in the water, connect the power cord to a properly installed Kasco control panel (C-85, C-95, etc.) with built-in ground fault protection according to the instructions and electrical schematics included with the panel. **Follow all local and national electrical codes for unit and control panel installation; consult a qualified electrician or service person if needed.**

REPLACEMENT PARTS

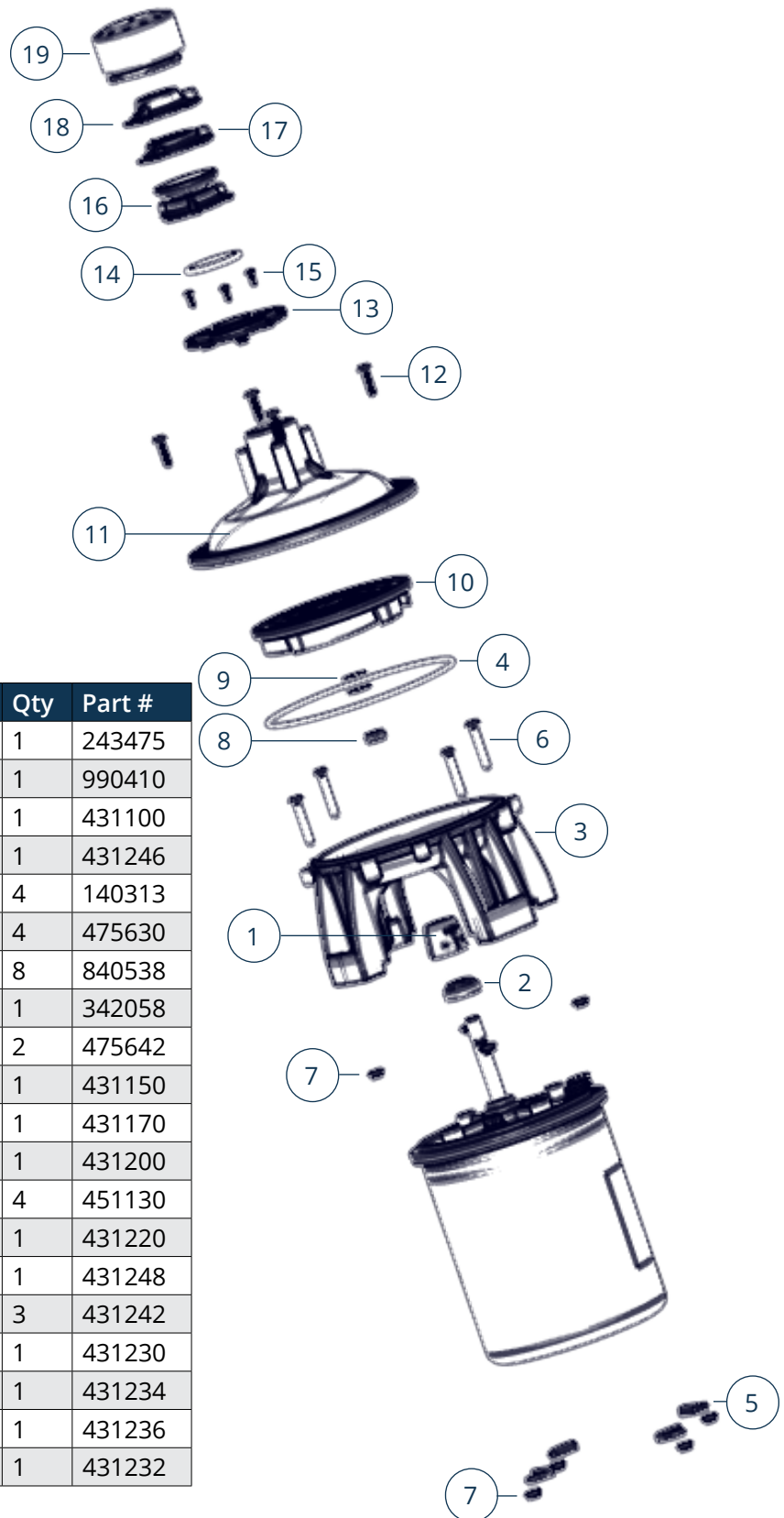

ID	Description	Qty	Part #
1	Anode assembly	1	243475
2	Debris flinger, .500 dia. shaft	1	990410
3	Baseplate	1	431100
4	O-ring, for base	1	431246
5	Retaining clip	4	140313
6	1/4"-20 x 1-3/4" bolt	4	475630
7	Nut, 1/4"-20 serrated flange	8	840538
8	1/2"-20 jam nut	1	342058
9	Washer, 1/2"	2	475642
10	Impeller, 3400J	1	431150
10	Impeller, 4400J	1	431170
11	Cone, 3400J, 4400J	1	431200
12	1/4"-20 x 1" hex head cap screw	4	451130
13	Nozzle plate	1	431220
14	O-ring, for nozzles	1	431248
15	Screw, #10-14 x 1/2 PH	3	431242
16	Nozzle, Sequoia	1	431230
17	Nozzle, Birch	1	431234
18	Nozzle, Cypress	1	431236
19	Nozzle, Linden assembly	1	431232

MAINTENANCE RECOMMENDATIONS

The following maintenance procedures can be utilized to ensure many years of quality performance from your Kasco equipment and reduce the need for more costly repair work.

PROPER INSTALLATION: Proper installation of Kasco equipment will include a power source with ground fault protection. The control panel included with the equipment has built-in ground fault protection for both the fountain and the lighting kit. Ground fault interrupters are a safety feature that can also alert you to electrical leaks in the equipment. It is extremely important to test the GFCI upon installation and every month thereafter to ensure proper operation. If you have repeat, consistent trips of the ground fault device, the equipment should be disconnected and removed from the water. The power cord should be inspected for damage, and you should contact your distributor or contact Kasco Marine at 715-262-4488 or sales@kascomarine.com for further instructions. A complete list of control panels can be found in the Accessories section of kascomarine.com.

OBSERVATION: Operating equipment should be observed on a regular basis (daily, if possible) for any reduction or variation in performance. If a change in performance is observed, the equipment should be disconnected from power and inspected.

WINTER STORAGE: In regions where there is significant freezing in the wintertime, the equipment should be removed from the water to protect it from the expansion pressure of ice. Fountains may keep some amount of ice open, but when water is thrust into the air it can make the existing ice thicker. Storage over winter is best in a location that is out of the sun and cool, but above 32° F. Store unit upside down if it will sit for a long period of time to ensure continued oil lubrication of seals; units that sit upright for many months or years have a greater likelihood of seals drying out.

CLEANING: Fountains should be removed from the water at least once per year (at the end of the season in cold climates) to clean the exterior of the system, especially the stainless-steel motor housing (can) that dissipates heat into the water. Any algae, calcium, or other build-up will become an insulator that blocks heat transfer and may lead to overheating and damage. In warmer regions, the unit should be removed and cleaned at least 2 – 3 times per year. In most cases, a power washer is sufficient if the unit and algae are still wet.

SEAL AND OIL REPLACEMENT: This is a sealed motor assembly, and seals will wear out over time (similar to brake pads on a car). Replacement of the seals and a change of oil after three years may add longevity to the operation of the motor, saving you the cost of more expensive repairs. In warmer climates where the fountain runs for a majority of the year or greater, it is wise to replace seals more often.

SACRIFICIAL ANODE: A sacrificial anode is supplied on the shaft of the unit for protection from corrosion and electrolysis. The anode should be updated/replaced if reduced to half the original size or if white in color. Corrosion from electrolysis is more commonly associated with saltwater or brackish water, but as a matter of precaution, it is important to periodically check the anode in all installations (at least every two to three months).

Seal replacement and all other repair services should be performed by Kasco Marine or a Kasco-trained Authorized Repair Center. Any alterations or changes made to Kasco units by an unauthorized source will void the warranty. This includes tampering with the unit, power cord, and/or control panel. Contact Kasco Marine at 715-262-4488 or sales@kascomarine.com for additional information and your closest Authorized Repair Center.

TROUBLESHOOTING TIPS

The following is provided to help diagnose a probable source of trouble. It is a guideline only and may not show all causes for all problems. For additional troubleshooting help, contact your local distributor or visit kascomarine.com for additional guidance. Note: you may need to refer to your owner's manual that was provided with your control panel for additional control panel settings and adjustments.

"My pattern is crooked or does not look even."

Wind can make a fountain pattern crooked. Also, make sure there is no clog or debris that is throwing off the pattern. If there is no wind or clog, then check to see if the nozzle is screwed down all the way and is sitting centered with the cone assembly.

"My fountain trips the ground fault interrupter in the C-25, C-85, or C-95."

This is the most common symptom of several possible problems. To correctly diagnose the problem, you will need to collect more information. A Ground Fault Interrupter (GFCI) breaker that trips can indicate an electrical service problem, water contamination in the unit and/or cord, bad breaker, control box problems, motor problems, etc. Try to find out the answers to these questions before you contact Kasco to narrow down the problem:

- How long does it take to trip the breaker?
- Does it always take the same amount of time to trip?
- How many times has it tripped?
- Have there been any electrical problems in the area recently?

"My fountain seems to run slowly."

This can also be a symptom of several possible problems. There could be an electrical problem where the unit is not getting the proper voltage. This could also indicate a problem with the motor of the unit, which needs to be looked at by an Authorized Repair Center. Check that the unit is receiving the proper voltage, and, if so, contact Kasco for further steps.

"My fountain hums, but will not start. When I spin the prop with a stick, it starts up."

(single phase units only) This indicates a problem with the Starting Capacitor. Each Kasco fountain is equipped with a Starting Capacitor to get the unit going when it is first plugged in. If it is operating but not spinning and can be started by spinning the prop with a stick, the Starting Capacitor needs to be replaced by an Authorized Repair Center.

"My fountain turns itself off and back on without the timer and without tripping the GFCI breaker."

(single phase units only) Each Kasco fountain has a Thermal Overload built in that will turn the unit off when it overheats. Once the unit has cooled down, it will start back up. If you are noticing these symptoms, the unit should be unplugged immediately because the Thermal Overload will continue to turn on and off until it burns out and damages the motor. The unit should be unplugged and taken out of the water to find the cause of the problem. The problem could be one of many, such as, low water levels, build-up on the unit to prevent heat dissipation, something inhibiting the free rotation of the shaft, etc. If something is caught in the unit or there is a build-up of algae, calcium or organic matter on the unit, remove the debris and, if caught early enough, the unit should be fine. Contact a Kasco representative before restarting the unit.

"My fountain flow seems to fluctuate and/or be less than usual."

This can occur because of a few different reasons. Most of the time, this symptom is caused by the unit being clogged with debris. A mat of weeds, many leaves, plastic bags, etc. can clog up the unit and cause it to be starved of water. If the unit does not have the proper amount of water, the flow or pattern will fluctuate up and down and look sporadic. If you are seeing these symptoms, unplug the unit and clean away the debris that is clogging up the screen. Another possibility if these symptoms are noticed is a chipped or damaged prop that is causing the unit to wobble and not pump properly. When the unit is unplugged, check the prop for damages and replace if damage is found.

"The GFCI breaker trips randomly and sporadically. Sometimes it is a few hours of operation, other times it can be days or weeks."

This is referred to as a Nuisance Trip. This usually occurs where the unit is installed a great distance from the initial electric service on the property where the ground stake is placed. It is caused by either induced current in the ground wire or a base voltage difference due to soil pH levels. To resolve the problem, contact an electrician and install a local grounding stake. This may eliminate the induced current and any base voltage differences. This problem can also be caused by a bad breaker or receptacle or having unbalanced incoming voltage lines.

WARRANTY

Warranty period:

3400JF, 3400HJF, 4400JF, 4400HJF = 2 years

Kasco® Marine, Inc. warrants this fountain to be free from defects in material or workmanship under normal use and service (excluding ropes, power cord, and propeller). The Kasco Marine, Inc. obligation under this warranty is limited to replacing or repairing free of charge any defective part within the warranty period from the date of shipment. Customer shall pay shipping charges for returning the unit to Kasco or an Authorized Repair Center.

THIS WARRANTY IS IN LIEU OF ANY OTHER WARRANTIES, EXPRESSED OR IMPLIED, AND ANY OTHER OBLIGATION OR LIABILITY WHATEVER ON THE PART OF KASCO MARINE, INC. AND IN NO EVENT SHALL KASCO MARINE, INC. BE LIABLE FOR ANY SPECIAL OR CONSEQUENTIAL DAMAGES.

Warranty is void if:

- The equipment is not maintained properly according to the Maintenance Recommendations supplied in this Owner's Manual.
- The equipment is returned for repair without the power cord.
- The unit, control panel, or power cord are altered in any way from original shipment. Cuts in the power cord are not covered under warranty.
- The equipment is damaged by unauthorized tampering.
- The sacrificial zinc anode around the motor shaft shows significant deterioration (not maintained according to Recommendations supplied in this Owner's Manual).

Warranty Claim Procedure: The best method for establishing warranty period is by keeping your original receipt and registering the equipment online at kascomarine.com under the Support section.

Once warranty coverage has been established, the unit may be sent to Kasco Marine or any Kasco Authorized Repair Center for evaluation and repair. See Repair section for more information regarding warranty repair procedure.



Kasco only accepts complete assemblies for warranty repair. We must receive the power cord and all other components with the motor as originally assembled. Kasco will bill the customer to replace any missing parts necessary for repair. It is not necessary to return the control panel, mount, or other parts with the motor assembly, unless specifically requested by a Kasco representative.

Please attach a repair form with the shipment. The repair form must include a name, physical address (for return delivery of the repaired unit), daytime phone number, and an e-mail address for correspondence regarding the warranty claim.

Any expedited shipping method for the return of the unit is at the customer's expense. Kasco Marine will return units repaired under warranty at our expense via ground freight within the continental United States.

NON-WARRANTY REPAIRS

Most failed equipment can be repaired at substantially lower costs than replacement with new. If your aerator requires repair and is no longer covered under warranty, please contact Kasco Marine or your local distributor for available options. Please ship according to the instructions on the previous provided.

Kasco Marine does estimates on repairs at the request of the customer. The request for estimate should be included in the letter that accompanies the returned unit and must include a daytime phone number and/or e-mail address. We will contact the customer with a total after the unit has been evaluated but before the work is performed.

All estimates that are rejected for repair will be destroyed unless otherwise directed by the customer. Rejected equipment can be returned at the customer's expense for shipping and handling charges.

Billing: All non-warranty repairs will be returned and billed to the customer unless otherwise directed. Kasco Marine accepts Visa and MasterCard credit card payments. Kasco Marine will call for credit card information upon completion of the estimate at the customer's request.

Please see the Support section of kascomarine.com for more information about warranty and repairs. Contact Kasco Marine at 715-262-4488 or sales@kascomarine.com for additional information and your closest Authorized Repair Center.

CONTACT US



Kasco Marine
800 Deere Road
Prescott, WI 54021



715.262.4488



kascomarine.com | sales@kascomarine.com



Intertek

3020379
ANSI/UL 778: 2016
Ed.6+R:22Feb2017
CSA C22.2 #108: 201

REPAIR CONTACT FORM

- Kasco requires that all equipment sent for repair MUST be accompanied by this form and marked to Repairs attention.
- Unit should be cleaned before shipping.
- Kasco is NOT responsible for shipping damage accrued in return shipment.
- It is the responsibility of the customer to ship and pay freight to Kasco.

Kasco Marine
 800 Deere Road
 Prescott, WI 54021
 Attn: Repairs

Note: Contact information should be that of the person or company to contact for repair information.

Company name			
Contact name	First name	Last name	
Address	Street		
	City		
	State		
	ZIP code		
Phone number	Primary	Alternate	
Email address			
Preferred method of contact (circle one)	Phone	Email	
Purchase order number			
Additional product information	Serial Number	Cord Length	
Information for Repair Technician			
Was this unit used in a chemical treatment or wastewater application? (circle one)	Yes	No	
Additional notes			