



Record purchase information:

Model No.:	Stock No.:
Serial No.:	
Purchased from:	
Date purchased:	

Operating Instructions and Parts Manual 8-inch Grinder with Belt Sander

Models IBGB-248/248VS/436/436VS

Variable speed model IBGB-436VS shown



JET
427 New Sanford Road
LaVergne, Tennessee 37086
Ph.: 800-274-6848
www.jettools.com

Part No. M-577248
Edition 2 05/2019
Copyright © 2019 JET



1.0 IMPORTANT SAFETY INSTRUCTIONS

WARNING – To reduce risk of injury:

1. Read and understand the entire owner's manual before attempting assembly or operation.
2. Read and understand the warnings posted on the machine and in this manual. Failure to comply with all of these warnings may cause serious injury.
3. Replace warning labels if they become obscured or removed.
4. This bench grinder is designed and intended for use by properly trained and experienced personnel only. If you are not familiar with the proper and safe operation of a bench grinder, do not use until proper training and knowledge have been obtained.
5. Do not use this bench grinder for other than its intended use. If used for other purposes, JET disclaims any real or implied warranty and holds itself harmless from any injury that may result from that use.
6. Always wear protective eye wear when operating machinery. Eye wear shall be impact resistant, protective safety glasses with side shields which comply with ANSI Z87.1 specifications. Use of eye wear which does not comply with ANSI Z87.1 specifications could result in severe injury from breakage of eye protection. (Everyday eyeglasses only have impact resistant lenses; they are NOT safety glasses.)
7. Use the grinder's eye shields and spark guards. Also use respiratory protection if the grinding or sanding operation is dusty.
8. Wear proper apparel. Do not wear loose clothing, neckties, rings, bracelets, or other jewelry which may get caught in moving parts. Non-slip footwear is recommended. Wear protective hair covering to contain long hair.
9. Wear protective clothing such as apron or safety shoes, where the grinding activity presents a hazard to the operator.
10. Wear ear protectors (plugs or muffs) if the particular work requires it.
11. Do not operate this machine while tired or under the influence of drugs, alcohol or any medication.
12. Make certain the switch is in the OFF position before connecting the machine to the power supply.
13. Make certain the machine is properly grounded.
14. Make all machine adjustments or maintenance with the machine unplugged from the power source.
15. Remove adjusting keys and wrenches. Form a habit of checking to see that keys and adjusting wrenches are removed from the machine before turning it on.
16. Keep safety guards in place at all times when the machine is in use. If removed for maintenance purposes, use extreme caution and replace the guards immediately after completion of maintenance.
17. Check damaged parts. Before further use of the machine, a guard or other part that is damaged should be carefully checked to determine that it will operate properly and perform its intended function. Check for alignment of moving parts, binding of moving parts, breakage of parts, mounting and any other conditions that may affect its operation. A guard or other part that is damaged should be properly repaired or replaced.
18. Provide for adequate space surrounding work area and non-glare, overhead lighting.
19. Keep the floor around the machine clean and free of scrap material, oil and grease.
20. Keep visitors a safe distance from the work area. Keep children away.
21. Make your workshop child proof with padlocks, master switches or by removing starter keys.
22. Give your work undivided attention. Looking around, carrying on a conversation and "horse-play" are careless acts that can result in serious injury.
23. Keep proper footing and balance at all times so that you do not fall into or lean against the grinding wheel or other moving parts. Do not overreach or use excessive force to perform any machine operation.
24. Disconnect grinder from power source before servicing and when changing abrasive wheel or sanding belt.
25. Use recommended accessories. The use of improper accessories may cause risk of injury to persons.
26. Turn off the machine before cleaning. Use a brush to remove chips or debris — do not use bare hands.

27. Never leave grinder running unattended. Turn power off and do not leave machine until wheel comes to a complete stop.
28. Remove loose items and unnecessary work pieces from the area before starting the grinder.
29. Don't use in dangerous environment. Don't use power tools in damp or wet location, or expose them to rain. Don't use this grinder in a flammable environment. Keep work area well lighted.
30. Keep work area clean. Cluttered areas and benches invite accidents.
31. Use the right tool. Don't force tool or attachment to do a job for which it was not designed.
32. Use proper extension cord. Make sure your extension cord is in good condition. When using an extension cord, be sure to use one heavy enough to carry the current your product will draw. An undersized cord will cause a drop in line voltage resulting in loss of power and overheating. Table 1 (see sect. 6.2) shows the correct size to use depending on cord length and nameplate ampere rating. If in doubt, use the next heavier gage. The smaller the gage number, the heavier the cord.
33. Maintain tools with care. Keep tools sharp and clean for best and safest performance. Follow instructions for lubricating and changing accessories.
34. Direction of feed: Feed work into a blade or cutter against the direction of rotation of the blade or cutter only.
35. Do not overtighten wheel nut.
36. Frequently clean grinding dust from beneath grinder.
37. Use grinding wheel suitable for speed of grinder.
38. Inspect abrasive wheels for cracks or other forms of damage. Perform a "ring test" to check wheel integrity. Do not use a faulty or damaged wheel.
39. Verify that maximum RPM of abrasive wheels is compatible with speed of grinder. Do not remove the blotter (label) from either side of a grinding wheel.
40. Allow abrasive wheel to reach full RPM before starting the grinding operation.
41. Do not crowd the work so that the wheel slows.
42. Tool rests should be adjusted to approximately 1/16" from wheel surface.
43. Do not grind on the side of a wheel; do all work on the grinding face or edge near the tool rest.
44. Do not grind aluminum or magnesium, as these may pose a fire hazard.
45. Use only the flanges that are furnished with the grinder.
46. Do not start the grinder while a workpiece is contacting the grinding wheel or the sanding belt.

⚠ WARNING: This product can expose you to chemicals including lead which is known to the State of California to cause cancer and birth defects or other reproductive harm. For more information go to <http://www.p65warnings.ca.gov>.

⚠ WARNING: Some dust, fumes and gases created by power sanding, sawing, grinding, drilling, welding and other construction activities contain chemicals known to the State of California to cause cancer and birth defects or other reproductive harm. Some examples of these chemicals are:

- lead from lead based paint
- crystalline silica from bricks, cement and other masonry products
- arsenic and chromium from chemically treated lumber

Your risk of exposure varies, depending on how often you do this type of work. To reduce your exposure to these chemicals, work in a well-ventilated area and work with approved safety equipment, such as dust masks that are specifically designed to filter out microscopic particles. For more information go to <http://www.p65warnings.ca.gov/> and <http://www.p65warnings.ca.gov/wood>.

Familiarize yourself with the following safety notices used in this manual:

⚠ CAUTION This means that if precautions are not heeded, it may result in minor injury and/or possible machine damage.

⚠ WARNING This means that if precautions are not heeded, it may result in serious, or possibly even fatal, injury.

2.0 Table of contents

Section	Page
1.0 IMPORTANT SAFETY INSTRUCTIONS	2
2.0 Table of contents	4
3.0 About this manual	5
4.0 Specifications	6
4.1 Mounting hole dimensions.....	7
4.2 Machine dimensions/work area.....	8
5.0 Carton contents.....	9
6.0 Setup and assembly.....	10
6.1 Tools required for assembly.....	10
6.2 Unpacking	10
6.3 Securing the grinder	10
6.4 Assembling eye shield bracket to spark guard.....	10
6.5 Installing spark guard/bracket	10
6.6 Eye shield.....	10
6.7 Grinder tool rest.....	10
6.8 Sanding table	11
6.9 Stand-off.....	11
6.10 Sanding tool rest	11
6.11 Dust port.....	11
7.0 Electrical connections	12
7.1 GROUNDING INSTRUCTIONS	12
7.2 Extension cords.....	12
7.3 Voltage conversion.....	13
8.0 Adjustments	13
8.1 Eye shield tilt adjustment.....	13
8.2 Spark guard.....	13
8.3 Tool rest	13
8.4 Sanding arm tilt	13
8.5 Sanding belt tracking.....	13
9.0 Operation	14
9.1 Operating controls.....	14
9.2 Precautions	15
10.0 User-maintenance.....	15
10.1 Installing/replacing sanding belt	15
10.2 Care of grinding wheels.....	15
10.3 Ring test.....	15
10.4 Changing wheels.....	16
10.5 Wheel balancing.....	16
10.6 Dressing the wheel.....	17
10.7 Wire wheel brushes.....	17
10.8 Cleaning	17
10.9 Tension lever tightness	17
10.10 Lubrication.....	17
10.11 Additional servicing	17
11.0 Optional accessories.....	18
12.0 Troubleshooting IBGB series Sander/Grinder.....	19
12.1 General mechanical and electrical problems	19
12.2 Digital readout error codes (Variable speed models).....	20
13.0 Replacement Parts.....	21
13.1.1 IBGB-248 Sander/Grinder – Exploded View	22
13.1.2 IBGB-248 Sander/Grinder – Parts List	23
13.2.1 IBGB-248VS Sander/Grinder – Exploded View	25
13.2.2 IBGB-248VS Sander/Grinder – Parts List	26
13.3.1 IBGB-436 Sander/Grinder – Exploded View	28
13.3.2 IBGB-436 Sander/Grinder – Parts List.....	29
13.4.1 IBGB-436VS Sander/Grinder – Exploded View	31
13.4.2 IBGB-436VS Sander/Grinder – Parts List	32
14.0 Electrical Connections.....	34

14.1 Wiring diagram for IBGB-248 and IBGB-436	34
14.2 Wiring diagram for IBGB-248VS and IBGB-436VS	34
15.0 Warranty and service	35

3.0 About this manual

This manual is provided by JET, covering the safe operation and maintenance procedures for a JET Model IBGB series Grinder/Belt Sander. This manual contains instructions on installation, safety precautions, general operating procedures, maintenance instructions and parts breakdown. Your machine has been designed and constructed to provide consistent, long-term operation if used in accordance with the instructions set forth in this document.

The operator is encouraged to familiarize him/herself with ANSI B7.1 – *Safety Requirements for Use, Care and Protection of Abrasive Wheels*.

If there are questions or comments, please contact your local supplier or JET. JET can also be reached at our web site: www.jettools.com.

Retain this manual for future reference. If the machine transfers ownership, the manual should accompany it.

 WARNING Read and understand the entire contents of this manual before attempting assembly or operation! Failure to comply may cause serious injury!

Register your product using the provided mail-in card, or register online:

<http://www.jettools.com/us/en/service-and-support/warranty/registration/>

4.0 Specifications

Table 1

Stock number		577248	578248	577436	578436
Model number		IBGB-248VS	IBGB-248	IBGB-436VS	IBGB-436
Motor and Electricals					
Motor	Type	Induction, with inverter	Induction, capacitor start, centrifugal switch	Induction, with inverter	Induction, capacitor start, centrifugal switch
	Horsepower	1HP			
	Phase	single			
	Voltage	115/230V, prewired 115V			
	Cycle	60 Hz			
	Listed FLA (full load amps)	7 / 3.5 A	11 / 5.5 A	7 / 3.5 A	11 / 5.5 A
	Starting capacitor	n/a	200MFD, 125VAC	n/a	200MFD, 125VAC
	Running capacitor	n/a	35µF, 250V	n/a	35µF, 250V
Input power required		Single phase 115V (or single phase 230V if rewired)			
On/off switch		TACT	toggle	TACT	toggle
Power transfer		Direct drive			
Power cord		SJT 16AWG x 3C, 6 ft. (183cm)			
Power plug provided		5-15P, 125V/15A			
Recommended circuit size ¹		15 A			
Sound emission without load ²		75 dB at 3 ft. (92cm)			
Grinding wheel and shaft					
Arbor diameter		5/8 in. (16 mm)			
Grinding wheel size (OD x W x Bore)		8 x 1 x 5/8 in.			
Grinding wheel grit provided		36			
Grinding wheel speed (RPM)		900~3600	3600	900~3600	3600
Grinding wheel material		Aluminum oxide			
Belt sander					
Sanding belt size (L x W)		48 x 2 in. (1219 x 50.8 mm)		36 x 4 in. (914.4 x 101.6 mm)	
Sanding belt grit provided		80			
Belt speed (SFPM)		1178~4712	4,712	942~3769	3,769
Sanding belt material		Aluminum oxide			
Sanding table tilt		45 deg. down			
Sanding table size		4-11/32 x 2-15/16 in. (110 x 75mm)		6-5/16 x 2-15/16 in. (160 x 75mm)	
Tool rest tilt		45 deg. down			
Tool rest size (L x W)		3-1/8 x 2-5/8 in. (79 x 67mm)		5-1/8 x 3-1/8 in. (130 x 80mm)	
Drive wheel size (Dia. x W)		5 x 2-1/16 in. (127.5 x 53mm)		4 x 4-1/16 (102.5 x 104mm)	
Dust port diameter		2 in. (50.8mm)			
Recommended min. dust extraction		350 CFM			
Dimensions					
Foot print (W x D)		9-1/2 W x 8-1/16 in. (241 x 204.8 mm)			
Overall dimensions (LxWxH)	Sanding bracket vertical	21-1/4 x 12-9/32 x 25-29/32 in. (539 x 312 x 658 mm)		23-7/32 x 12-7/32 x 20-3/4 in. (590 x 310 x 527 mm)	
	Sanding bracket parallel	21-1/4 x 24-3/4 x 13-15/16 in. (539 x 629 x 354 mm)		23-7/32 x 19-1/2 x 13-15/16 in. (590 x 496 x 354 mm)	
Shipping dimensions (L x W x H)		26-9/16 x 24-19/32 x 16-15/16 in. (675 x 625 x 430 mm)		21-15/32 x 24-19/32 x 16-15/16 in. (545 x 625 x 430 mm)	
Weights					
Net weight		78 lbs. (35.30kg)	77 lbs. (35.02 kg)	77 lbs. (34.95 kg)	76 lbs. (34.65 kg)
Shipping weight		96 lbs. (43.66 kg)	95 lbs. (43.38 kg)	93 lbs. (42.04 kg)	92 lbs. (41.74 kg)

		IBGB-248VS	IBGB-248	IBGB-436VS	IBGB-436
Main materials					
Grinder	Motor housing	Sheet metal			
	End cover	Aluminum (Grinder side) / Cast iron (Belt sander side)			
	Base	Cast iron			
	Tool rest	Cast iron			
	Inner wheel guard	Cast iron			
	Outer wheel guard	Aluminum			
	Flange washer	Cast iron			
	Eye shield	Polycarbonate			
Sander	Belt table	Cast iron			
	Belt table bracket	Sheet metal			
	Tool rest	Sheet metal			
	Tool rest bracket	Sheet metal			

¹ subject to local and national electrical codes.

² The specified values are emission levels and are not necessarily to be seen as safe operating levels. As workplace conditions vary, this information is intended to allow the user to make a better estimation of the hazards and risks involved only.

L = length, W = width, H = height, D = depth

OD = outside diameter

n/a = not applicable

The specifications in this manual were current at time of publication, but because of our policy of continuous improvement, JET reserves the right to change specifications at any time and without prior notice, without incurring obligations.

4.1 Mounting hole dimensions

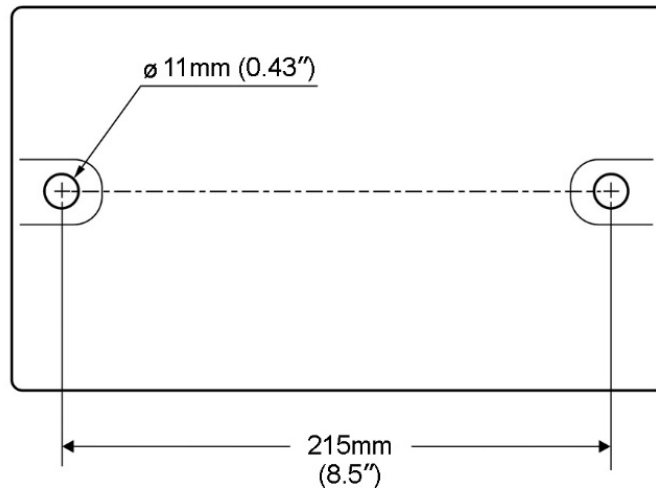

Figure 4-1 Mounting dimensions, all models

4.2 Machine dimensions/work area

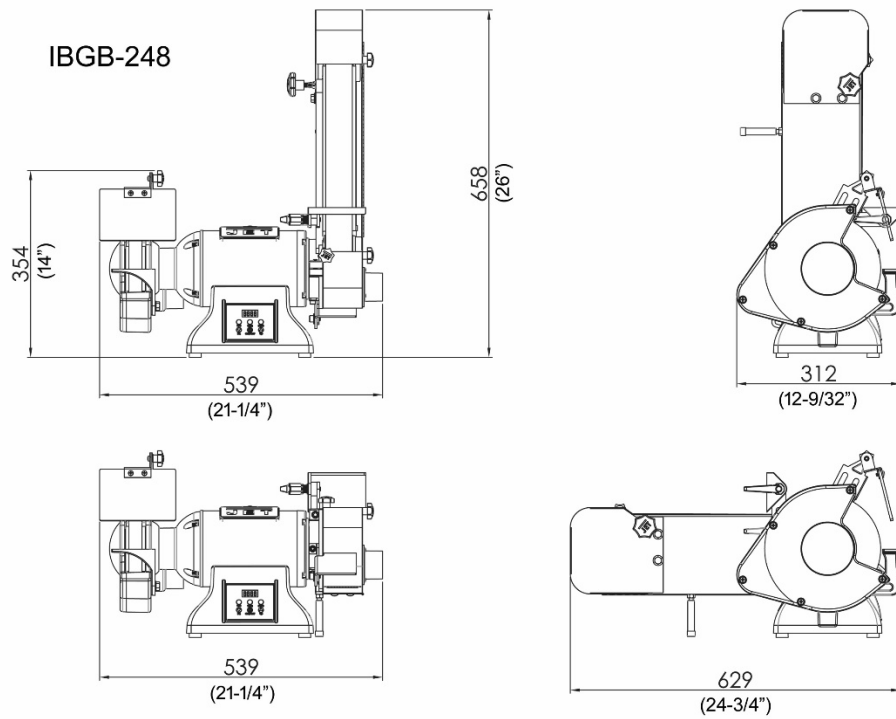

Figure 4-2: dimensions for IBGB-248/-248VS (primary dimensions in millimeters)

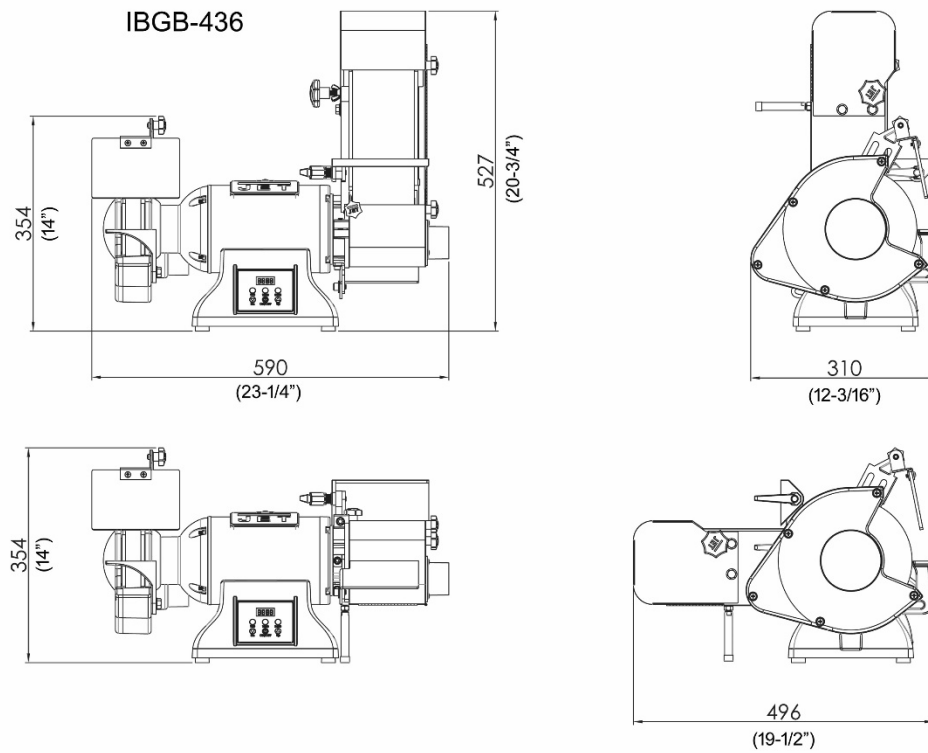

Figure 4-3: dimensions for IBGB-436/-436VS (primary dimensions in millimeters)

5.0 Carton contents

Refer to Figures 5-1 thru 5-4. The identifying letters are used in the assembly instructions.

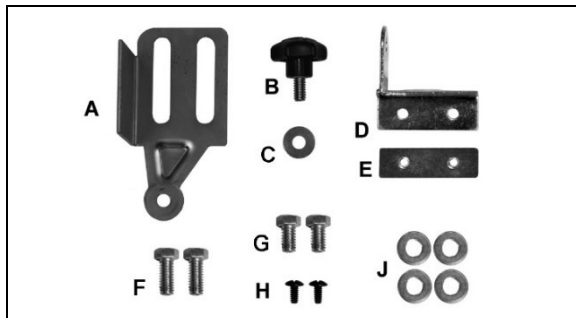

Figure 5-1

Eye shield hardware		Qty.
Part no. IBG8-100		
A	Spark guard	1
B	Lock knob	1
C	Flat washer, 1/4"	1
D	Eye shield bracket	1
E	Eye shield plate	1
F	Hex cap screw, 3/8 x 5/8"	2
G	Hex cap screw, 3/8 x 1/2"	2
H	Truss head screw, 3/16 x 1/2"	2
J	Flat washers 3/8"	4



Figure 5-2

Hardware package		Qty.
Part no. IBGB248-HP or IBGB436-HP		
K	Tool rest (for sanding belt)	1
L	Flat washer 3/8	1
M	Adjustable handle 3/8 x 5/8L	1
N	Stand-off	1
O	Socket hd cap screw 5/16 x 1/2	1
P	Flat washer 5/16	1
R	Ext. tooth lock washer M8	1
S	Bracket plate	1
T	Flat washer 5/16	1
U	Adjustable handle 5/16 x 1L	1



Figure 5-3

Dust port package		Qty.
	Dust port	1
	Truss head screw 3/16 x 3/8	3



Figure 5-4

Additional items		Qty.
V	Eye shield	1
W	Sanding table	1
X	Hex wrench 6 x 140L mm	1
Y	Grinder tool rest	1
Z	Wheel dresser	1
	Grinder with Belt Sander (not shown)	1
	Sanding belt 80G (preinstalled)	1
	Grinding wheel 36G (preinstalled)	1

6.0 Setup and assembly

6.1 Tools required for assembly

Cross-point (Phillips) screwdriver
14mm (or adjustable) wrench
3mm hex wrench
6mm hex wrench

6.2 Unpacking

Separate all parts from the packing material. Check each part against *sect. 5.0, Carton contents*, and make certain that all items are accounted for. (Check whether any parts have been pre-mounted to the grinder.) Notify your dealer or JET if missing or damaged items are discovered. Do not discard any packing material until grinder is assembled and operating properly.

The IBGB Grinder/Belt Sander requires only minimal assembly. Additional tools may be needed for fastening the grinder to a workbench or stand. For your safety, do not plug the grinder into a power source until all assembly and adjustments are complete.

▲WARNING Make sure that bench grinder is unplugged and power switch is in OFF position. Do not plug in the grinder to power until it is inspected for shipping damage, fully assembled, and moved to its permanent location. Failure to comply may cause serious injury.

▲WARNING Do not operate this machine without all guards and shields in place and in working order. Failure to comply may cause serious injury.

▲WARNING Chipped or cracked wheels can break up and cause serious damage to the grinder and/or severe injury to the operator. Regularly inspect wheels for damage.

6.3 Securing the grinder

To prevent the machine from moving during operation, it should be securely mounted to a work bench or grinder stand. Fasteners for mounting are not included with the grinder.

1. Align mounting holes on grinder with predrilled holes in bench or grinder stand. Figure 4-1 shows hole centers for mounting.
2. Insert M10 (or 3/8") bolts through the holes and secure with washers and nuts.

An optional JET pedestal stand (not included) is available for your grinder. See *sect. 11.0*.

IMPORTANT: The grinder's base plate contains ventilation holes for heat dissipation. This is especially important on the variable speed models,

as it helps keep the circuit board at an acceptable temperature. These holes should not be obstructed. If the rubber pads are removed for mounting to a table, allow an opening in the table below the grinder for air circulation. However, it is recommended the rubber pads be left on, as they allow air circulation as well as vibration dampening.

6.4 Assembling eye shield bracket to spark guard

Refer to Figure 6-1.

Note: Spark guard (A) and eye shield bracket (D) are marked L for left side assembly. Assemble these using Figure 6-1 as a guide.

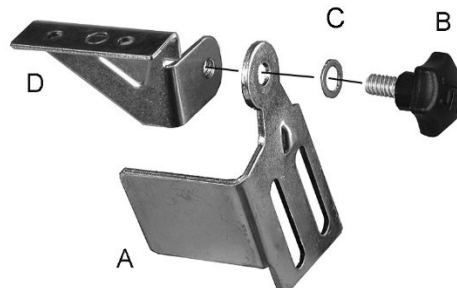

Figure 6-1: bracket to spark guard

6.5 Installing spark guard/bracket

Refer to Figure 6-2.

1. Install spark guard and mounting bracket assembly to the left wheel housing with two 3/8 x 1/2" hex cap screws (G) and two 3/8" flat washers (J).
2. The spark guard (A₁) should be adjusted to within 1/16" of the grinding wheel surface or other accessory being used. As the wheel wears down, the spark guard must be re-adjusted to maintain this 1/16" distance.

6.6 Eye shield

Refer to Figure 6-2.

1. Insert two 3/16" x 1/2" truss head screws (H) through bracket, eye shield (V), and plate (E) which contains threaded mounting holes.
2. Tighten screws (H).

6.7 Grinder tool rest

Refer to Figure 6-2.

1. Install tool rest (Y) by inserting two 3/8" x 3/4" hex cap screws (F) through two 3/8" flat washers (J), through the tool rest (Y), into the wheel housing.
2. The tool rest should be adjusted to within 1/16" of the grinding wheel or other accessories being used. As the wheel wears down, the tool rest

must be readjusted to maintain a maximum 1/16" clearance.

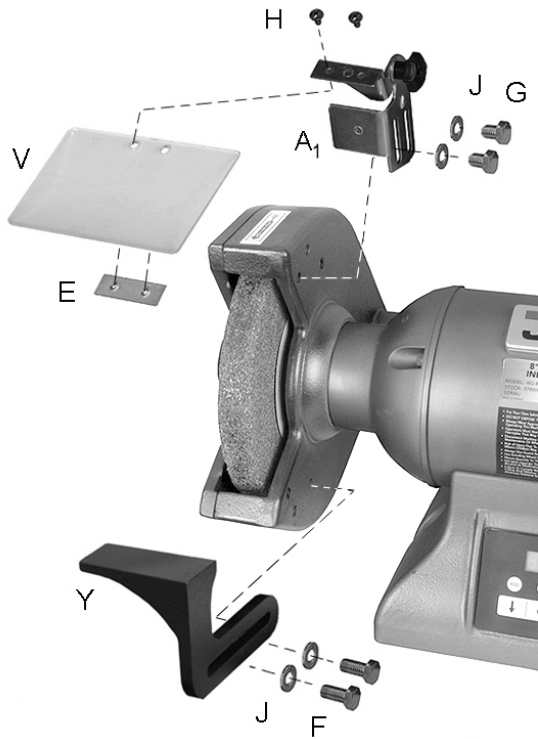

Figure 6-2: guard and tool rest

6.8 Sanding table

Install bracket plate, table and handles, as shown in Figure 6-3.

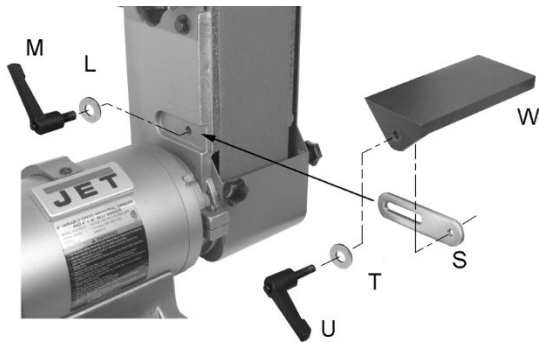

Figure 6-3: sanding belt table

The quickest method of installing a handle is to start the handle into the threads of the hole, then pull out on the handle while turning the screw with a 3mm hex wrench until tight. See Figure 6-4.

To reposition a handle for convenience without affecting its tightness, pull out on it, rotate, then release it, allowing it to resettle upon the screw.

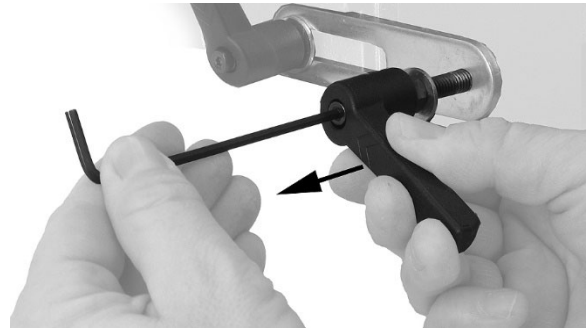

Figure 6-4: installing handles

6.9 Stand-off

1. Install stand-off (shown installed in Figure 8-2) into threaded hole in back of sanding arm.
2. Loosen screw (A, Figure 6-5) with 6mm hex wrench and lower sanding arm to horizontal position.
3. Turn stand-off in or out as needed until sanding arm is level with workbench.
4. Tighten hex nut against sanding arm to secure setting of stand-off.

6.10 Sanding tool rest

Loosen screw (A, Figure 6-5) with 6mm hex wrench and lower sanding arm to horizontal position.

Install tool rest as shown in Figure 6-5, using a 6mm hex wrench.

Note: The tool rest can remain installed when not in use. Simply adjust it outward to allow opening and closing of drive wheel cover. Adjust it inward before raising arm to vertical position.

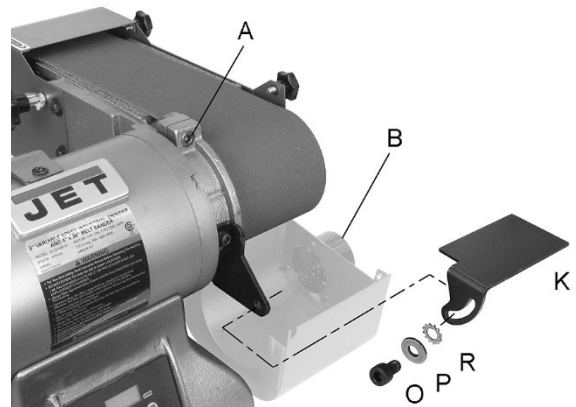

Figure 6-5: Sanding tool rest

6.11 Dust port

Install dust port (B, Figure 6-5) over exhaust hole in sanding arm, with three screws.

It is recommended that a dust collection system designed for metal dust and shavings be connected to the ports on grinder and belt sander, using 2-1/2" inside diameter hose with hose clamp (not provided).

7.0 Electrical connections

⚠WARNING Electrical connections should be made by a qualified electrician in compliance with all relevant codes. This tool must be properly grounded.

The **IBGB** Grinder/Belt Sander is prewired for 115V single phase power, and is supplied with a plug designed for use on a circuit with a grounded outlet that looks like the one pictured in A, Figure 7-1. The grinder may be converted to 230V single phase power, see sect. 7.3.

Before connecting to power source, be sure switch is in *off* position.

It is recommended that the grinder be connected to a 15-amp circuit with circuit breaker or fuse. If using fuses, they should be time-delay fuses marked “D”. **Local codes take precedence over recommendations.**

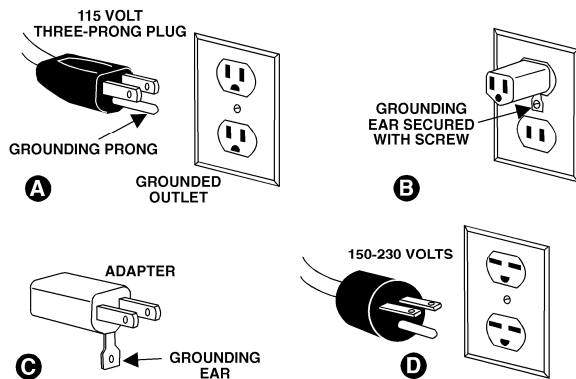

Figure 7-1: plug configurations

7.1 GROUNDING INSTRUCTIONS

1. All Grounded, Cord-connected Tools:

This tool must be grounded. In the event of a malfunction or breakdown, grounding provides a path of least resistance for electric current to reduce the risk of electric shock. This tool is equipped with an electric cord having an equipment-grounding conductor and a grounding plug. The plug must be plugged into a matching outlet that is properly installed and grounded in accordance with all local codes and ordinances.

Do not modify the plug provided - if it will not fit the outlet, have the proper outlet installed by a qualified electrician.

Improper connection of the equipment-grounding conductor can result in a risk of electric shock. The conductor with insulation having an outer surface that is green with or without yellow stripes is the equipment-grounding conductor. If repair or replacement of the electric cord or plug is necessary, do not connect the equipment-grounding conductor to a live terminal.

⚠WARNING Check with a qualified electrician or service personnel if the grounding instructions are not completely understood, or if in doubt as to whether the tool is properly grounded. Failure to comply may cause serious or fatal injury.

Use only 3-wire extension cords that have 3-prong grounding plugs and 3-pole receptacles that accept the tool's plug.

Repair or replace damaged or worn cord immediately.

2. Grounded, cord-connected tools intended for use on a supply circuit having a nominal rating **less than 150 volts:**

This tool is intended for use on a circuit that has an outlet that looks like the one illustrated in A, Figure 7-1. An adapter, shown in B and C, may be used to connect this plug to a 2-pole receptacle as shown in B if a properly grounded outlet is not available. The temporary adapter should be used only until a properly grounded outlet can be installed by a qualified electrician.

Note: In Canada, the use of a temporary adaptor is not permitted by the Canadian Electrical Code, C22.1.

The green-colored rigid ear, lug, and the like, extending from the adapter must be connected to a permanent ground such as a properly grounded outlet box.

3. Grounded, cord-connected tools intended for use on a supply circuit having a nominal rating between **150 - 250 volts, inclusive:**

This tool is intended for use on a circuit that has an outlet that looks like the one illustrated in D, Figure 7-1. A grounding plug may be installed, that looks like the plug illustrated in D; or the grinder may be “hard-wired” to a panel, provided there is a disconnect for the operator.

Make sure the tool is connected to an outlet having the same configuration as the plug. No adapter is available or should be used with this tool. If the tool must be reconnected for use on a different type of electric circuit, the reconnection should be made by qualified service personnel; and after reconnection, the tool should comply with all local codes and ordinances.

7.2 Extension cords

The use of extension cords is discouraged. Try to position equipment near the power source. If an extension cord becomes necessary, use only three-wire extension cords that have three-prong grounding type plugs and three-prong receptacles that accept the tool's plug. Replace or repair damaged or worn cord immediately.

Make sure your extension cord is in good condition, and is heavy enough to carry the current your product will draw. An undersized cord will cause a drop in line voltage resulting in loss of power and overheating.

Table 2 shows the correct size to use depending on cord length and nameplate ampere rating. If in doubt, use the next heavier gage. The smaller the gage number (AWG), the heavier the cord.

Ampere Rating		Volts	Total length of cord in feet			
More Than	Not More Than	120	25	50	100	150
		240	50	100	200	300
			AWG			
0	6		18	16	16	14
6	10		18	16	14	12
10	12		16	16	14	12
12	16		14	12	Not Recommended	

*Extension Cord Recommendations
Table 2*

7.3 Voltage conversion

The grinder/belt sander is prewired for 115 volt input power, but can be converted to 230 volt input, as follows.

7.3.1 Non-variable speed models (IBGB-248 and IBGB-436)

1. Turn grinder over and remove base plate.
2. Reconnect the leads according to wiring diagram in *sect. 13.0*.
3. Remove existing plug from power cable and attach a UL/CSA listed plug designed for 230V power.

7.3.2 Variable speed models (IBGB-248VS and IBGB-436VS)

Remove existing plug from power cable and attach a UL/CSA listed plug designed for 230V power.

8.0 Adjustments

8.1 Eye shield tilt adjustment

1. Loosen lock knob (A₁, Figure 8-1).
2. Adjust eye shield (A₂) to desired tilt angle.
3. Tighten lock knob.

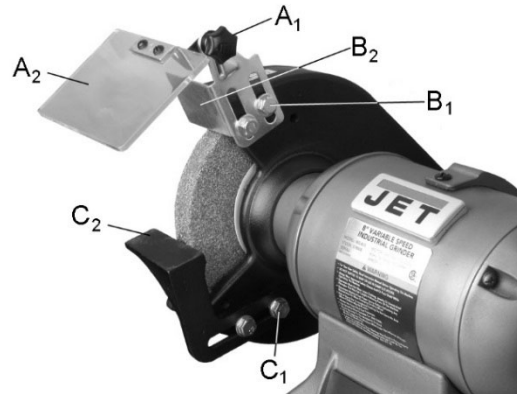

Figure 8-1: eye shield adjustment

8.2 Spark guard

As the wheel wears down, the spark guard must be re-adjusted to maintain a 1/16" distance.

Refer to Figure 8-1.

1. Loosen two hex cap screws (B₁) with 14mm wrench.
2. Slide spark guard (B₂) to 1/16" distance from grinding wheel surface.
3. Tighten screws (B₁).

8.3 Tool rest

As the wheel wears down, the tool rest must be re-adjusted to maintain a 1/16" distance.

Refer to Figure 8-1.

1. Loosen two hex cap screws (C₁) with 14mm wrench.
2. Slide tool rest (C₂) to a distance of 1/16" from grinding wheel.
3. Tighten screws (C₁).

8.4 Sanding arm tilt

Loosen screw (A, Figure 6-5) and manually move arm to vertical or horizontal position. Retighten screw.

CAUTION Make sure screw is tight when using sanding arm. Failure to comply may result in vertical sanding arm falling back into horizontal position during operation, resulting in possible injury.

8.5 Sanding belt tracking

1. Turn grinder/sander OFF.
2. Move sanding belt by hand to check tracking. If belt migrates to one side or the other, adjust as follows.
3. Loosen wing nut (E, Figure 8-2).

4. Turn knob (F) while moving the belt until belt completely covers drive wheel and stays centered. Turn handle clockwise to shift belt to the right (away from grinder), counterclockwise to shift belt to the left (toward grinder). NOTE: This adjustment is sensitive, turn handle in small increments and allow belt to respond to changes.
5. Tighten wing nut (E) to secure setting.
6. Turn on machine to verify setting at low speed.

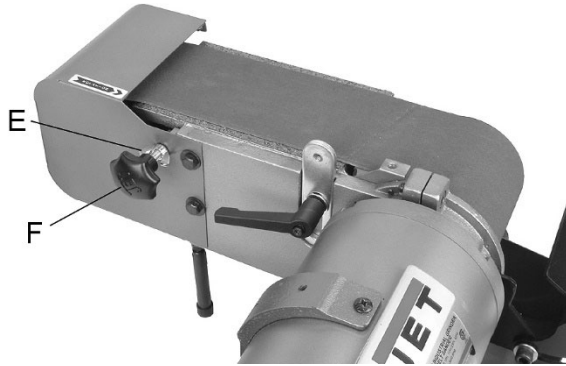

Figure 8-2: belt tracking

9.0 Operation

A bench grinder is designed for hand-grinding operations such as sharpening chisels, screwdrivers, drill bits, removing excess metal, and smoothing and polishing metal surfaces.

⚠WARNING Always use approved safety glasses or face shield while operating tool. Failure to comply may cause serious injury.

The IBGB Grinder/Sander offers multiple working methods:

Grinding wheel – A medium-grain, 36-grit wheel is provided, and is effective when a considerable amount of metal must be removed, or when obtaining a smooth finish is not important. A finer grain abrasive grinding wheel (not provided) can be mounted for sharpening tools or grinding to close size tolerances because it removes metal more gradually for precision grinding and achieves a smoother finish.

Belt and platen (horizontal or vertical position) – Workpieces of any length can be worked on the belt and against the platen. The table or tool rest should be tightened in place and used to support the workpiece. The table can tilt down to 45-degrees, and may also be used as a fence for workpiece support when sanding arm is horizontal.

The general-purpose 80-grit sanding belt is useful for many applications, including radiusing, deburring and finishing/polishing of both ferrous and non-ferrous alloys.

Contour sanding (horizontal position) – Contoured workpieces can be sanded over the drive wheel. Open end cover, adjust tool rest and tighten in place.

9.1 Operating controls

Note: After extended operation, the grinder housing may be warm to the touch. This is not abnormal.

IBGB-248, IBGB-436: Pull paddle switch (A, Figure 9-1) to start tool, push to stop. The safety key (A₁) can be removed to prevent unauthorized use of the grinder. The safety key must be inserted to restart the grinder.

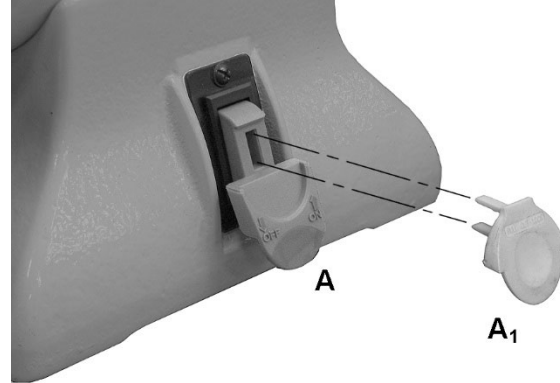

Figure 9-1: safety key

IBGB-248VS, IBGB-436VS: Press on/off button on keypad (Figure 9-2) to start or stop. Press either of the numbered buttons to start machine at the designated speed. Press arrow buttons to change rotation speed in 100 RPM increments.

The digital readout will flash briefly during start up and speed adjustments. Press button to toggle between RPM and SFPM display.

The grinder will automatically shut off after approximately 1-1/2 minutes of inactivity.

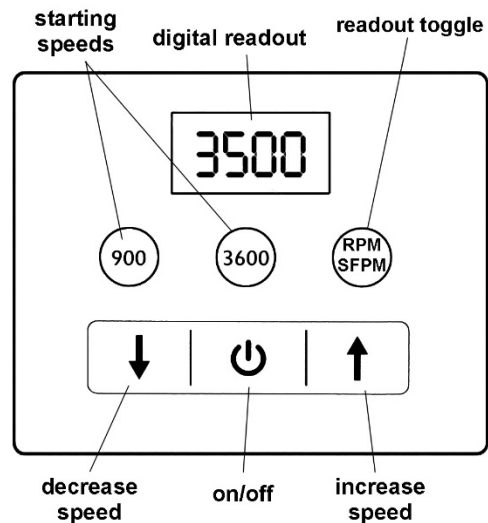

Figure 9-2: keypad (VS models only)

9.2 Precautions

9.2.1 Wheel grinding

1. Before starting grinder, turn grinding wheel by hand to verify that it is clear of obstruction and turns freely. The tool rest and spark guard should not touch the wheel.
2. Keep tool rest and spark guard to within 1/16" of grinding wheel.
3. Turn on grinder and allow it to reach full running speed before starting to grind.
4. Adjust the eye shield as needed.
5. Keep a steady, moderate pressure on the workpiece and keep it moving at an even pace for smooth grinding. Pressing too hard overheats the motor and prematurely wears the grinding wheel. Note the original bevel angle on the item to be sharpened and try to maintain the same shape. The grinding wheel should rotate into the object being sharpened.
6. If grinding a narrow workpiece, slide it laterally across width of wheel. Using full width of wheel will help prevent a groove from forming at one place on the wheel.
7. Keep a water pot filled with water and dip your work into it regularly to prevent overheating. Overheating can weaken metals. Do not apply water directly to grinding wheel.
8. Do not use the side of the grinding wheel; this puts dangerous stress on the wheel.
9. When wheel becomes loaded or dull, use an approved grinding wheel dresser and dress the wheel face.
10. At all times, keep hands and fingers away from pinch points.

9.2.2 Belt sanding

1. Move belt by hand to ensure that wheels rotate freely without obstruction, table or tool rest does not contact belt, and belt tracks properly.
2. Use the entire width of the belt to reduce wear in one place.
3. At all times, keep hands and fingers away from pinch points.

10.0 User-maintenance

For safety, turn switch to OFF and remove plug from power source outlet before performing maintenance on the grinder/sander.

If the power cord is worn, cut or damaged in any way, have it replaced immediately.

10.1 Installing/replacing sanding belt

1. Disconnect grinder/sander from power source.

2. Unscrew knobs and open side guard.
3. Pull tension lever (D, Figure 10-1) outward to compress spring and de-tension belt.
4. Remove old belt by sliding it off wheels. Install new belt, centering it on the wheels. *Make sure arrow printed on back of sanding belt matches direction of belt movement.*
5. Push lever (D) inward to tension belt.
6. Verify proper belt tracking, *sect. 8.5.*
7. Close side cover and secure with knobs before operating.

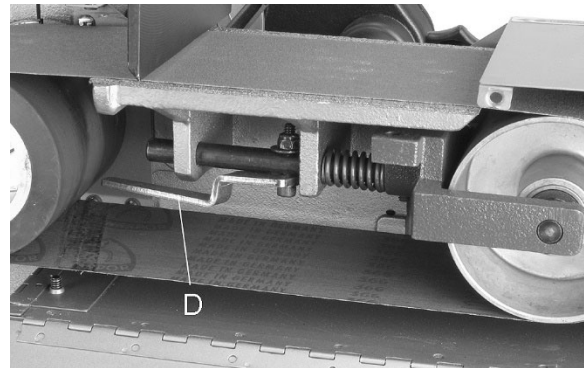

Figure 10-1: installing sanding belt

10.2 Care of grinding wheels

In normal use, grinding wheels may become cracked, grooved, rounded at the edges, chipped, out of true or loaded with foreign material.

Cracked wheels should be replaced IMMEDIATELY. The other conditions can be remedied with a dressing tool. New wheels sometimes require dressing to make them round. See *sect. 10.5.*

10.3 Ring test

Before replacing a grinding wheel, perform this simple test on the replacement wheel:

1. Loop a piece of string through the grinding wheel hole and suspend the wheel by holding up the string.
2. Tap the wheel with a scrap of wood or wooden dowel.
3. A good wheel will "ring"; a defective wheel will "thud". Discard any wheel that does not "ring".

An internal defect may not be apparent by visual inspection alone. The ring test may identify an internal crack or void.

10.4 Changing wheels

The JET bench grinder comes equipped with a general purpose grinding wheel. Wheels vary according to types of abrasive, hardness, grit size, and structure. Contact your local distributor for the proper grinding wheel or wire wheel brush for your application.

If you replace a wheel, obtain one with a safe rated speed at least as high as the *NO LOAD RPM* marked on the grinder's nameplate. The replacement wheel must be 8" OD x 1" W x 5/8" Bore.

The bench grinder will accept most polishing, buffing, and wire wheels available at dealers and hardware stores.

⚠WARNING The use of any other accessory is not recommended and may result in serious injury.

To change a wheel (see Figure 10-2):

1. Disconnect grinder from power source.
2. Loosen spark guard (B) and tool rest (C) and move them away from the wheel.
3. Remove wheel guard using a cross-point or flathead screwdriver.
4. Stabilize wheel by placing a wood wedge between wheel and tool rest.

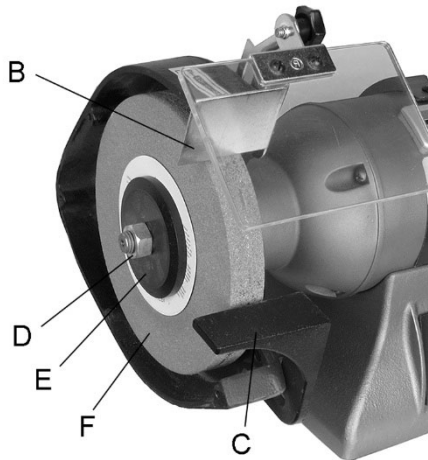

Figure 10-2: wheel replacement

5. Unscrew arbor nut (D) with wrench. **Note:** Left-hand threads; turn nut *clockwise* to loosen.
6. Remove outer flange (E), wheel (F), and inner flange.
7. Clean flanges. Check the flanges to make sure they are flat. Wheel flanges that are not flat will cause the wheel to wobble.
8. Inspect the new grinding wheel and perform a "ring test" (sect. 10.3). Do not install a damaged wheel.

9. Install inner flange, wheel (F), outer flange (E) and nut (D) on the shaft. Tighten nut counter-clockwise.

⚠CAUTION Do not overtighten nut; this may cause the wheel to crack. Maximum safe torque on nut is 20 lbf·ft (270 kgf·cm).

10. Reinstall wheel guard. Adjust spark guards and tool rests to 1/16" clearance from wheel.

10.5 Wheel balancing

With the grinder **unplugged from the power source**, and arbor nut snugged down, rotate wheel by hand and observe its motion.

A grinding wheel has proper balance when:

1. The wheel's outside face spins true and round; that is, its circumference rotates concentric to the arbor.
2. There is no side-to-side wobble.

The operator who takes time to patiently perform needed adjustments will be rewarded by a wheel running true, and accurate grinding of work pieces.

10.5.1 Adjusting concentricity

If the outside face is not rotating concentric to arbor, try shifting the wheel closer to arbor centerline before tightening the nut.

Another method of achieving concentricity is the use of a wheel dresser. "Dressing" is the removal of the current layer of abrasive to expose a fresh surface. A wheel dresser is also used to "true" a wheel; that is, to make the grinding surface parallel to the tool rest, so the entire wheel face presents an even surface to the work piece. Proper use of a wheel dresser will eliminate high spots and result in concentric rotation about the arbor, as well as minimize vibration. See sect. 10.6.

10.5.2 Correcting side-to-side wobble

The IBGB series Grinders have large, machined flanges, making wobble unlikely if a good quality grinding wheel is used. Should a wheel exhibit need for adjustment:

1. Loosen nut and rotate the outer flange a little. Snug the nut and spin the wheel by hand to check.
2. If wobble still exists, continue repeating step 1, rotating outer flange incrementally in the same direction. See Figure 10-3. Make sure to keep the wheel in the same position each time.
3. If complete rotation of outer flange has proved ineffective, remove nut, outer flange, and wheel (keep wheel in same orientation by placing a pencil mark on it somewhere for reference). Then rotate inner flange about 90° and repeat the above steps for the outer flange.

- Continue this combination of flange movements until the wobble is eliminated.

If required, a shim made of paper or card stock may be placed between flange and wheel side.



Figure 10-3: wheel balancing

NOTE: Very slight wobble may still exist at spin-up and spin-down, but will not affect normal speed operation.

10.6 Dressing the wheel

Below is a general procedure for dressing a grinding wheel.

WARNING Use safety glasses or face shield during dressing operations.

- Back off the tool rest enough to allow the dresser to hook over its inside edge (Figure 10-4). Tighten tool rest in position.
- Turn on grinder and allow it to reach operating speed.
- Set the wheel dresser on the rest and bring it into contact with the wheel by raising its handle. Hold the dresser firmly.

Note: If sparks appear, increase the pressure of the dresser discs against the wheel.

- Move the dresser evenly left and right across the wheel face until the wheel looks clean and is square to the tool rest.
- Remove the dresser, and adjust the tool rest to 1/16" away from the newly dressed wheel.

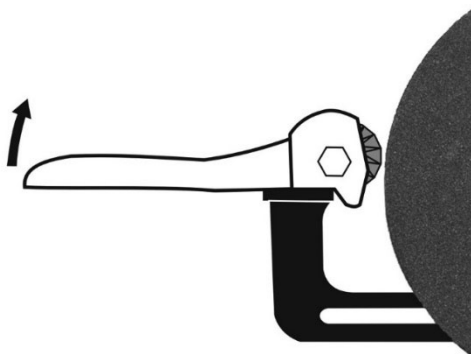

Figure 10-4: wheel dressing

10.7 Wire wheel brushes

Wire brushing (not provided) is a fast way to remove rust scale, burrs, and paint from metal. Use coarse wire brushes for hard cleaning jobs. Use fine wire brushes for polishing and finish work. When the brush tips become dull, reverse the brush on the grinder.

10.8 Cleaning

CAUTION Metal shavings may still be hot from recent grinding operations. Make sure shavings and debris are cold before cleaning the grinder. Use a brush or rag to clear shavings, not bare hands.

CAUTION Avoid use of the following cleaning chemicals or solvents: gasoline, carbon tetrachloride, chlorinated solvents, ammonia and household detergents containing ammonia.

Brush all shavings from the motor housing, tool rest, wheel guards and sanding belt areas. Clean area beneath grinder base.

Periodically use a cleaning stick (not provided) against the abrasive belt to remove build-up.

If the abrasive belt becomes loaded, it can be cleaned by soaking within a solvent. Allow to dry completely before reinstalling.

10.9 Tension lever tightness

If sanding belt tension lever becomes loose, hold the lock nut with an 11mm wrench, and tighten screw with 5mm hex wrench (Figure 10-5). Lever should be snug but still easily moved.

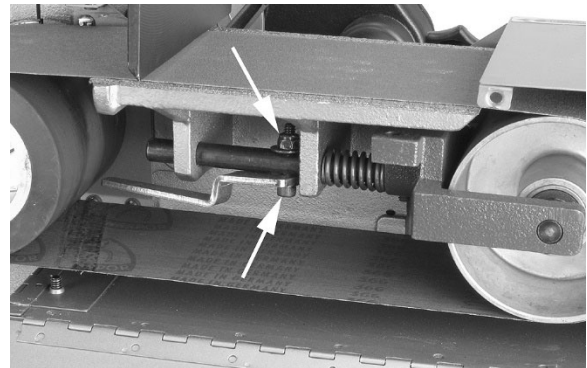

Figure 10-5

10.10 Lubrication

All motor and wheel bearings are permanently lubricated and sealed at the factory and require no additional lubrication.

10.11 Additional servicing

Any additional servicing on the grinder should be performed by an authorized service representative.

11.0 Optional accessories

These accessory items, purchased separately, will accommodate your JET bench grinder. Contact your dealer to order, or call JET at the phone number on the cover.



578172
Stand for Grinders



578173
Deluxe Stand for Grinders



578100
Flexible 3W LED Lamp
(includes two 1/4 x 3/8 mounting screws)

The following accessories are for using the Grinder with the JET #414800 (JDSC-505) Dust Collection Stand:

414825 Reducer, 3 in. to 2.5 in.

414811 0.6M Hose, Heat Resistant, \varnothing 2.5 x 24.4 in.

12.0 Troubleshooting IBGB series Sander/Grinder

12.1 General mechanical and electrical problems

▲WARNING Some corrections may require a qualified electrician.

Symptom	Possible Cause	Correction
Motor will not start.	No incoming power.	Verify that plug is properly inserted into receptacle. If so, check main panel for tripped breaker or blown fuse.
	Non-variable speed models: Safety key is missing.	Make sure safety key is inserted.
	Wheel(s) cannot rotate because of obstruction.	Unplug and turn wheel by hand to ensure free movement. Restart.
	Fuse blown or circuit breaker open.	Re-set. May be too many machines on one circuit.
	Motor cord cut or abraded.	Replace with new cord.
	Plug on cord is faulty.	Replace with new plug.
	Low line voltage.	Check power line for proper voltage.
	Faulty switch.	Replace switch.
	Faulty capacitor.	Replace capacitor.
	Open circuit in motor or loose connection.	Inspect all lead connections on motor for loose or open connections.
Motor faulty.	Have motor inspected.	
Motor will not start; fuses blow or circuit breakers trip.	Too many electrical machines running on same circuit.	Turn off other machines and try again. Use dedicated circuit if necessary.
	Incorrect fuse.	Try time delay fuse, or go to circuit with higher rated fuse or circuit breaker.
	Wheel(s) cannot rotate because of obstruction.	Unplug and turn wheel by hand to ensure free movement. Clear any obstructions and restart.
	Undersized extension cord.	Use correct size extension cord.
	Short circuit in line cord or plug.	Inspect cord or plug for damaged insulation and shorted wires.
Motor fails to develop full power.	Short circuit in motor or loose connections.	Inspect all connections on motor for loose or shorted terminals or worn insulation.
	Low line voltage.	Check power line for proper voltage.
Motor overheats.	Faulty motor or capacitor.	Contact JET technical service.
	Motor overloaded.	Reduce pressure against wheel or platen. Make sure grit size is appropriate for the job.
Motor stalls, resulting in blown fuses or tripped breaker.	Motor overloaded.	Reduce load on motor; do not press so hard.
	Capacitor failure.	Contact JET technical service.
	Short circuit in motor or loose connections.	Inspect connections on motor for loose or shorted terminals or worn insulation.

Symptom	Possible Cause	Correction
Motor stalls (cont.)	Low voltage.	Correct the low voltage conditions.
	Incorrect fuses or circuit breakers in power line.	Install correct fuses or circuit breakers.
Motor slows.	Motor overloaded.	Reduce load to motor; do not press so hard.
	Low line voltage.	Check power line for proper voltage.
	Loose connections.	Inspect connections.
Frequent fuse or circuit breaker failure.	Motor overload.	Reduce load to motor; do not press so hard.
	Electrical circuit overload; too many electrical machines running on same circuit.	Turn off other machines and try again.
	Incorrect fuse or circuit breaker.	Have electrician upgrade service to outlet.
Excessive vibration.	Wheel out of balance; wobbling or not rotating concentric to arbor.	Dress wheel or replace it. Adjust wobble by rotating flange as needed.
	Improper mounting.	Secure grinder/sander firmly to bench or stand.
Sanding belt will not tension or de-tension properly.	Tension rod is "sticking"; movement obstructed.	Clean any debris from tension rod and spring area. Lubricate spring if needed.
	Spring is worn or damaged.	Replace spring.
	Set screw which holds tension rod to wheel carrier is loose.	Tighten set screw.

Table 3

12.2 Digital readout error codes (Variable speed models)

Message	Possible Cause	Correction *
OCL	Internal electronic overload has been tripped.	Do not overload motor; reduce pressure of workpiece against wheels.
OH	IGBT protection activated.	Inspect wire connections to U/V/W for possible short circuits. Verify that motor rating corresponds to AC motor drive output power.
OE	Excessive input voltage (exceeds AC driver limits).	Use correct voltage.
LE1	Low voltage; AC motor driver detects that DC bus voltage has fallen below minimum threshold	Make sure input voltage falls within range of AC motor input voltage range. Check for abnormal load in motor.
LP1	Low input voltage (below AC driver limits)	Use correct voltage.

Table 4

13.0 Replacement Parts

Replacement parts are listed on the following pages. To order parts or reach our service department, call 1-800-274-6848 Monday through Friday, 8:00 a.m. to 5:00 p.m. CST. Having the Model Number and Serial Number of your machine available when you call will allow us to serve you quickly and accurately.

Non-proprietary parts, such as fasteners, can be found at local hardware stores, or may be ordered from JET. Some parts are shown for reference only, and may not be available individually.

13.1.1 IBGB-248 Sander/Grinder – Exploded View

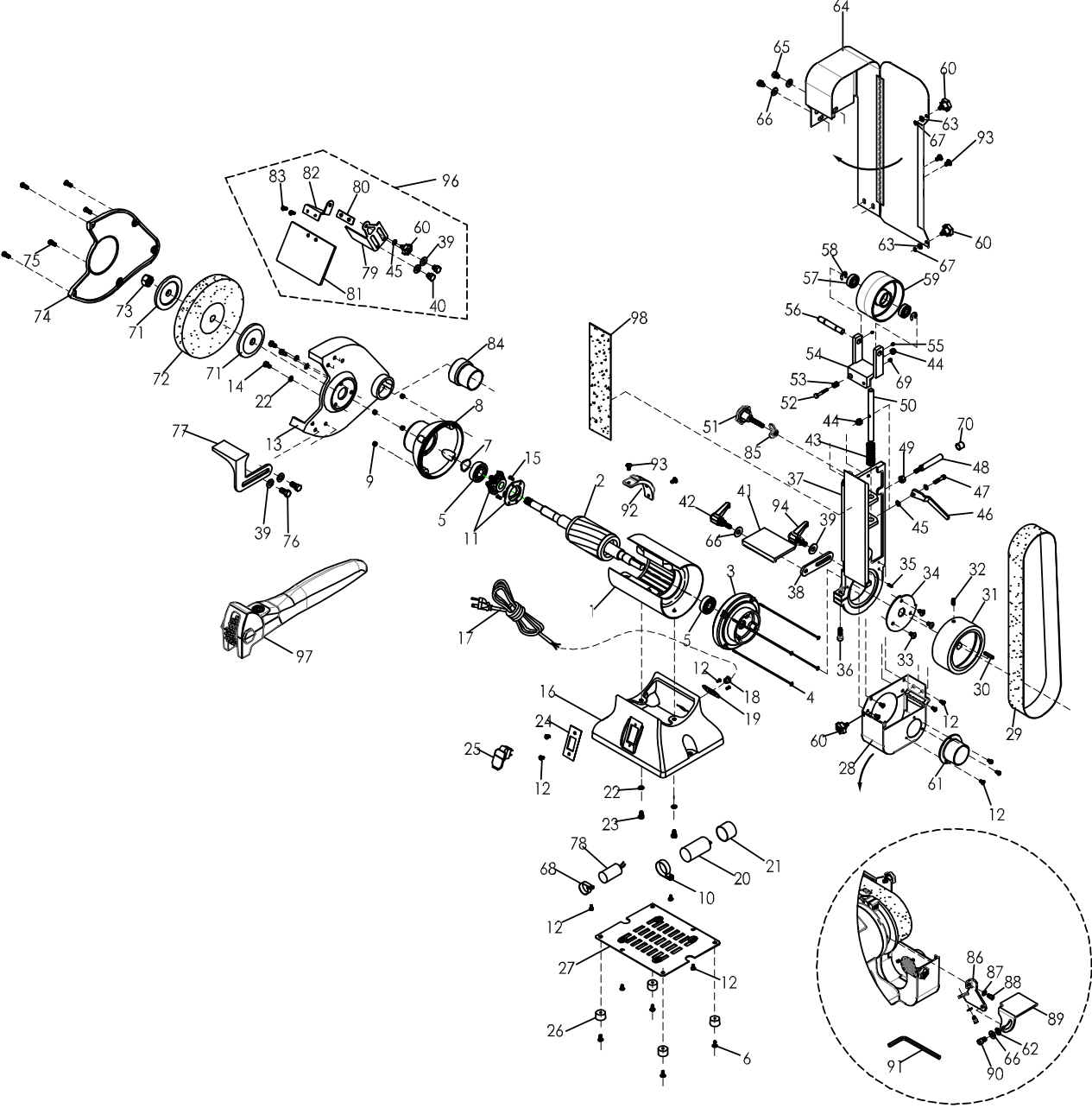

13.1.2 IBGB-248 Sander/Grinder – Parts List

Index No	Part No	Description	Size	Qty
1	IBGB248-01	Motor Housing w/ Stator		1
2	IBGB248-02	Rotor		1
3	IBGB248-03	End Cover		1
4	IBGB248-04	Cross Head Screw	M5 x 210 x 30S	4
5	BB-6204ZZ	Ball Bearing	6204ZZ	2
6	IBG8-36	Truss Head Screw	3/16"-24 x 1/2"	4
7	IBGB248-07	Wave Washer		1
8	IBG8-19	End Bell		1
9	TS-1540031	Hex Nut	M5	4
10	IBG8-05	Capacitor Bracket		1
11	IBG8-41	Centrifugal Switch Assembly		1
12	IBG8-04	Truss Head Screw	3/16"-24 x 3/8"	18
13	IBG8-21	Wheel Guard		1
14	TS-0050021	Hex Cap Screw	1/4"-20 x 5/8"	3
15	IBG8-04	Truss Head Screw	3/16"-24 x 3/8"	2
16	IBG8-10	Base		1
17	IBG8-46	Power Cord		1
18	IBG8-47	Strain Relief		1
19	IBG8-11	Cord Plate		1
20	IBG8-06	Start Capacitor	200MFD, 125VAC	1
21	IBG8-07	Capacitor Cover		1
22	TS-0720071	Lock Washer	1/4"	5
23	TS-0050011	Hex Cap Screw	1/4"-20 x 1/2"	2
24	IBG8-12	Switch Plate		1
25	IBG8-13	Switch with Safety Key		1
	IBG8-13-1	Safety Key (not shown)		1
26	IBG8-02	Rubber Pad		4
27	IBG8-03	Base Plate		1
28	IBGB248-28	Drive Wheel Cover		1
29	IBGB248-29	Sanding Belt	W 2" x L 48", 80 Grit	1
30	IBGB248-30	Key, Dbl Rd Hd	3/16" x 3/16" x 1-1/4"	1
31	IBGB248-31	Drive Wheel	Dia. 5" x W 2"	1
32	TS-0267041	Set Screw	1/4"-20 x 3/8"	1
33	IBGB248-33	Truss Head Screw	1/4"-20 x 3/8"	3
34	IBGB248-34	Positioning Plate		1
35	IBGB248-35	Spring Pin	Dia. 5 x 14	1
36	TS-0208061	Socket Hd Cap Screw	5/16"-18 x 1"	1
37	IBGB248-37	Sanding Belt Bracket		1
38	IBGB248-38	Bracket Plate *		1
39	TS-0680042	Flat Washer *	3/8"	5
40	TS-0060011	Hex Cap Screw	3/8"-16 x 1/2"	2
41	IBGB248-41	Sanding Table		1
42	IBGB248-42	Adjustable Handle *	5/16"-18 x 1"	1
43	IBGB248-43	Spring		1
44	TS-0640071	Nylon Lock Hex Nut	1/4"-20	2
45	TS-0680021	Flat Washer	1/4"	3
46	IBGB248-46	Tension Handle		1
47	TS-0207071	Socket Hd Cap Screw	1/4"-20 x 1-1/4"	1
48	IBGB248-48	Stand-Off	Dia. 13 x L 67	1
49	TS-0561021	Hex Nut	5/16"-18	1
50	IBGB248-50	Support Post		1
51	IBGB248-51	Tracking Adjustment Knob	M8 x 35	1
52	F000114	Round Head Screw	1/4"-20 x 1-1/4"	1
53	IBGB248-53	Spring		1
54	IBGB248-54	Wheel Carrier		1
55	IBGB248-55	Set Screw	3/16"-24UNF x 1/4"	2
56	IBGB248-56	Shaft		1
57	BB-6201VV	Ball Bearing	6201BR	2
58	6284728	E-Ring	12mm	2
59	IBGB248-59	Driven Wheel	Dia. 4-1/4" x W 2"	1

Index No	Part No	Description	Size	Qty
60	IBGB248-60	Knob	1/4"	4
61	IBGB248-61	Dust Port	Dia. 2"	1
62	F002176	External Tooth Lock Washer *	M8	1
63	TS-1550041	Flat Washer	M6	2
64	IBGB248-64	Belt Cover		1
65	6293385	Hex Cap Screw	5/16"-18 x 3/8"	2
66	TS-0680031	Flat Washer *	5/16"	4
67	IBGB248-67	S-Ring	6mm	3
68	IBG8-48	Capacitor Bracket		1
69	TS-0267021	Set Screw	1/4"-20 x 1/4"	1
70	IBGB248-70	Rubber Sleeve		1
71	IBG8-22	Wheel Flange		2
72	IBG8-23	Wheel	#36 Grit, 8" Dia.	1
73	IBG8-24	Hex Nut (Left Hand Thread)	5/8"-11UNC	1
74	IBG8-25	Wheel Cover		1
75	IBG8-26	Truss Head Screw	1/4"-20 x 3/4"	5
76	IBG8-29	Hex Cap Screw	3/8"-16 x 5/8"	2
77	IBG8-27	Tool Rest-Left		1
78	IBG8-49	Running Capacitor	35µF, 250V	1
79	IBG8-32	Spark Guard - Left		1
80	IBG8-35	Eye Shield Plate		1
81	IBG8-33	Eye Shield		1
82	IBG8-34	Eye Shield Bracket - Left		1
83	IBG8-36	Truss Head Screw	3/16"-24 x 1/2"	2
84	IBGB248-84	Dust Port Adapter		1
85	TS-154306	Wing Nut	M8	1
86	IBGB248-86	Bracket Plate		1
87	TS-0720071	Lock Washer	1/4"	2
88	TS-0207021	Socket Hd Cap Screw	1/4"-20 x 1/2"	2
89	IBGB248-89	Tool Rest *		1
90	TS-0208021	Socket Hd Cap Screw *	5/16"-18 x 1/2"	1
91	IBGB248-91	Allen Wrench	6 x L140mm	1
92	IBG8-50	Lamp Fixed Bracket		1
93	IBGB248-33	Truss Head Screw	1/4"-20 x 3/8"	2
94	IBGB248-94	Adjustable Handle *	3/8"-16 x 3/4"	1
96	IBG8-100	Eye Shield Assembly - Left		1
97	IBG8-54	Dresser Assembly		1
98	IBGB248-98	Graphite Sheet		1
	JET-92-73R	JET Logo (not shown)	92 x 38 mm	1
	LM000381	I.D./Warning Label, IBGB-248 (not shown)		1
	IBGB248-HP	Hardware Package *		1

Hardware package includes items marked with asterisk (*).

13.2.1 IBGB-248VS Sander/Grinder – Exploded View

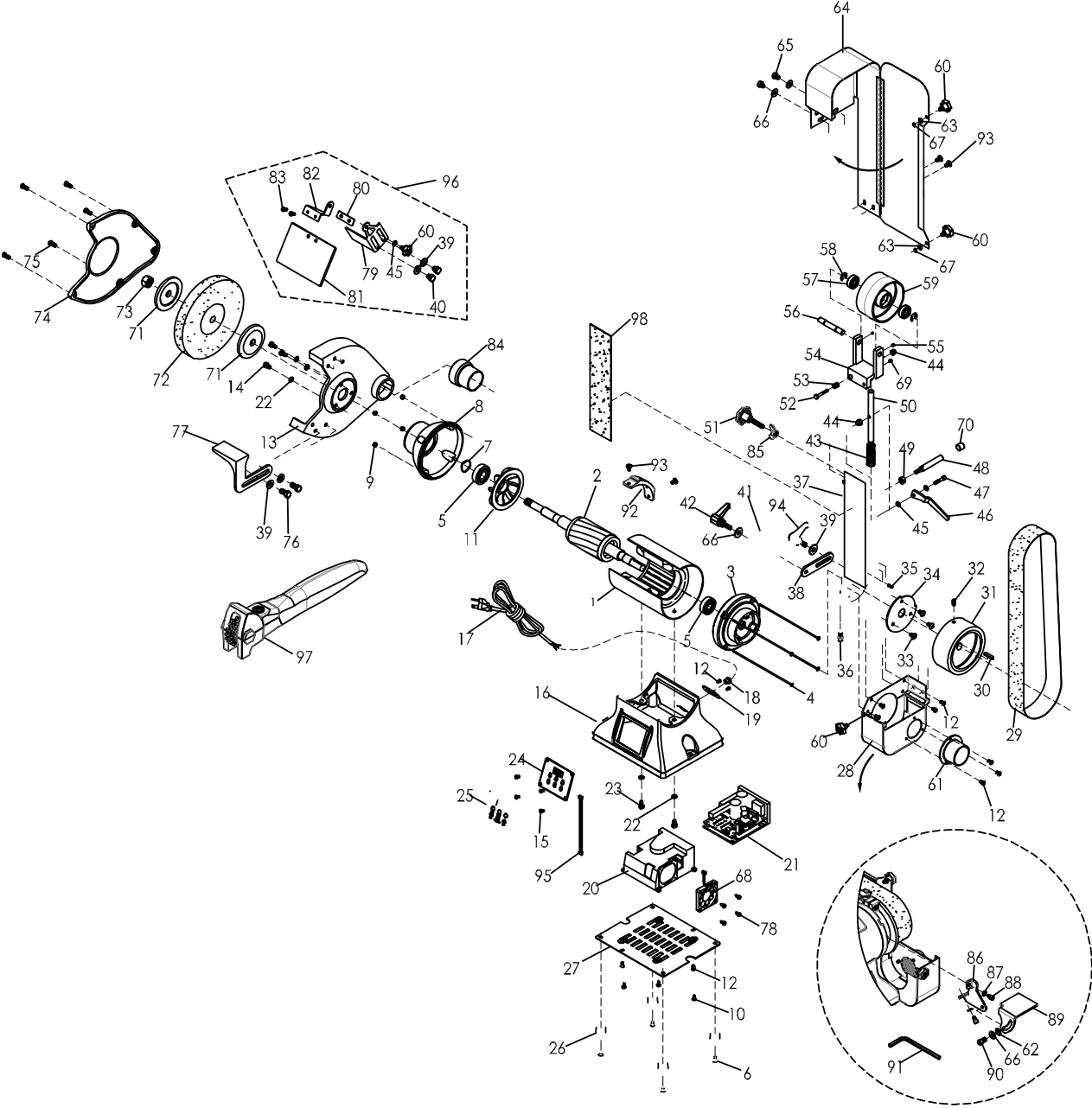

13.2.2 IBGB-248VS Sander/Grinder – Parts List

Index No	Part No	Description	Size	Qty
1	IBGB248VS-01	Motor Housing w/ Stator		1
2	IBGB248VS-02	Rotor		1
3	IBGB248-03	End Cover		1
4	IBGB248-04	Cross Head Screw	M5 x 210 x 30S	4
5	BB-6204ZZ	Ball Bearing	6204ZZ	2
6	IBG8-36	Truss Head Screw	3/16"-24 x 1/2"	4
7	IBGB248-07	Wave Washer		1
8	IBG8-19	End Bell		1
9	TS-1540031	Hex Nut	M5	4
10	990811	Pan Head Tapping Screw	M3.5 x 12	4
11	IBG8-17	Motor Fan		1
12	IBG8-04	Truss Head Screw	3/16"-24 x 3/8"	16
13	IBG8-21	Wheel Guard		1
14	TS-0050021	Hex Cap Screw	1/4"-20 x 5/8"	3
15	6286927	Flat Head Screw	M4 x 10	4
16	IBG8VS-10	Base		1
17	IBG8-46	Power Cord		1
18	IBG8-47	Strain Relief		1
19	IBG8-11	Cord Plate		1
20	IBG8VS-06	Electrical Box		1
21	IBGB248VS-21	Inverter PCB		1
22	TS-0720071	Lock Washer	1/4"	5
23	TS-0050011	Hex Cap Screw	1/4"-20 x 1/2"	2
24	IBGB248VS-24	Control Panel w/ Digital Readout (includes #25)		1
25	IBGB248VS-25	Panel Decal		1
26	IBG8-02	Rubber Pad		4
27	IBG8-03	Base Plate		1
28	IBGB248-28	Drive Wheel Cover		1
29	IBGB248-29	Sanding Belt	W 2" x L 48", 80 Grit	1
30	IBGB248-30	Key	3/16" x 3/16" x 1-1/4"	1
31	IBGB248-31	Drive Wheel	Dia. 5" x W 2"	1
32	TS-0267041	Set Screw	1/4"-20 x 3/8"	1
33	IBGB248-33	Truss Head Screw	1/4"-20 x 3/8"	3
34	IBGB248-34	Positioning Plate		1
35	IBGB248-35	Spring Pin	Dia. 5 x 14	1
36	TS-0208061	Socket Hd Cap Screw	5/16"-18 x 1"	1
37	IBGB248-37	Sanding Belt Bracket		1
38	IBGB248-38	Bracket Plate *		1
39	TS-0680042	Flat Washer *	3/8"	5
40	TS-0060011	Hex Cap Screw	3/8"-16 x 1/2"	2
41	IBGB248-41	Sanding Table		1
42	IBGB248-42	Adjustable Handle *	5/16"-18 x 1"	1
43	IBGB248-43	Spring		1
44	TS-0640071	Nylon Lock Hex Nut	1/4"-20	2
45	TS-0680021	Flat Washer	1/4"	3
46	IBGB248-46	Tension Handle		1
47	TS-0207071	Socket Hd Cap Screw	1/4"-20 x 1-1/4"	1
48	IBGB248-48	Stand-Off	Dia. 13 x L 67	1
49	TS-0561021	Hex Nut	5/16"-18	1
50	IBGB248-50	Support Post		1
51	IBGB248-51	Tracking Adjustment Knob	M8 x 35	1
52	F000114	Round Head Screw	1/4"-20 x 1-1/4"	1
53	IBGB248-53	Spring		1
54	IBGB248-54	Wheel Carrier		1
55	IBGB248-55	Set Screw	3/16"-24 x 1/4"	2
56	IBGB248-56	Shaft		1
57	BB-6201VV	Ball Bearing	6201BR	2
58	6284728	E-Ring	12mm	2
59	IBGB248-59	Driven Wheel	Dia. 4-1/4" x W 2"	1
60	IBGB248-60	Knob	1/4"	4

Index No	Part No	Description	Size	Qty
61	IBGB248-61	Dust Port	Dia. 2"	1
62	F002176	External Tooth Lock Washer *	M8	1
63	TS-1550041	Flat Washer	M6	2
64	IBGB248-64	Belt Cover		1
65	6293385	Hex Cap Screw	5/16"-18 x 3/8"	2
66	TS-0680031	Flat Washer *	5/16"	4
67	IBGB248-67	S-Ring	6mm	3
68	IBGB248VS-68	Cooling Fan		1
69	TS-0267021	Set Screw	1/4"-20 x 1/4"	1
70	IBGB248-70	Rubber Sleeve		1
71	IBG8-22	Wheel Flange		2
72	IBG8-23	Wheel	#36 Grit, 8" Dia.	1
73	IBG8-24	Hex Nut (Left Hand Thread)	5/8"-11UNC	1
74	IBG8-25	Wheel Cover		1
75	IBG8-26	Truss Head Screw	1/4"-20 x 3/4"	5
76	IBG8-29	Hex Cap Screw	3/8"-16 x 5/8"	2
77	IBG8-27	Tool Rest-Left		1
78	990811	Pan Head Tapping Screw	M3.5 x 12	4
79	IBG8-32	Spark Guard - Left		1
80	IBG8-35	Eye Shield Plate		1
81	IBG8-33	Eye Shield		1
82	IBG8-34	Eye Shield Bracket - Left		1
83	IBG8-36	Truss Head Screw	3/16"-24 x 1/2"	2
84	IBGB248-84	Dust Port Adapter		1
85	TS-154306	Wing Nut	M8	1
86	IBGB248-86	Bracket Plate		1
87	TS-0720071	Lock Washer	1/4"	2
88	TS-0207021	Socket Hd Cap Screw	1/4"-20 x 1/2"	2
89	IBGB248-89	Tool Rest *		1
90	TS-0208021	Socket Hd Cap Screw *	5/16"-18 x 1/2"	1
91	IBGB248-91	Allen Wrench	6 x L140mm	1
92	IBG8-50	Lamp Fixed Bracket		1
93	IBGB248-33	Truss Head Screw	1/4"-20 x 3/8"	2
94	IBGB248-94	Adjustable Handle *	3/8"-16 x 3/4"	1
95	IBGB248VS-95	Signal Line		1
96	IBG8-100	Eye Shield Assembly - Left		1
97	IBG8-54	Dresser Assembly		1
98	IBGB248-98	Graphite Sheet		1
	JET-92-73R	JET Logo (not shown)	92 x 38 mm	1
	LM000382	I.D./Warning Label, IBGB-248VS (not shown)		1
	IBGB248-HP	Hardware Package *		

Hardware package includes items marked with asterisk (*).

13.3.1 IBGB-436 Sander/Grinder – Exploded View

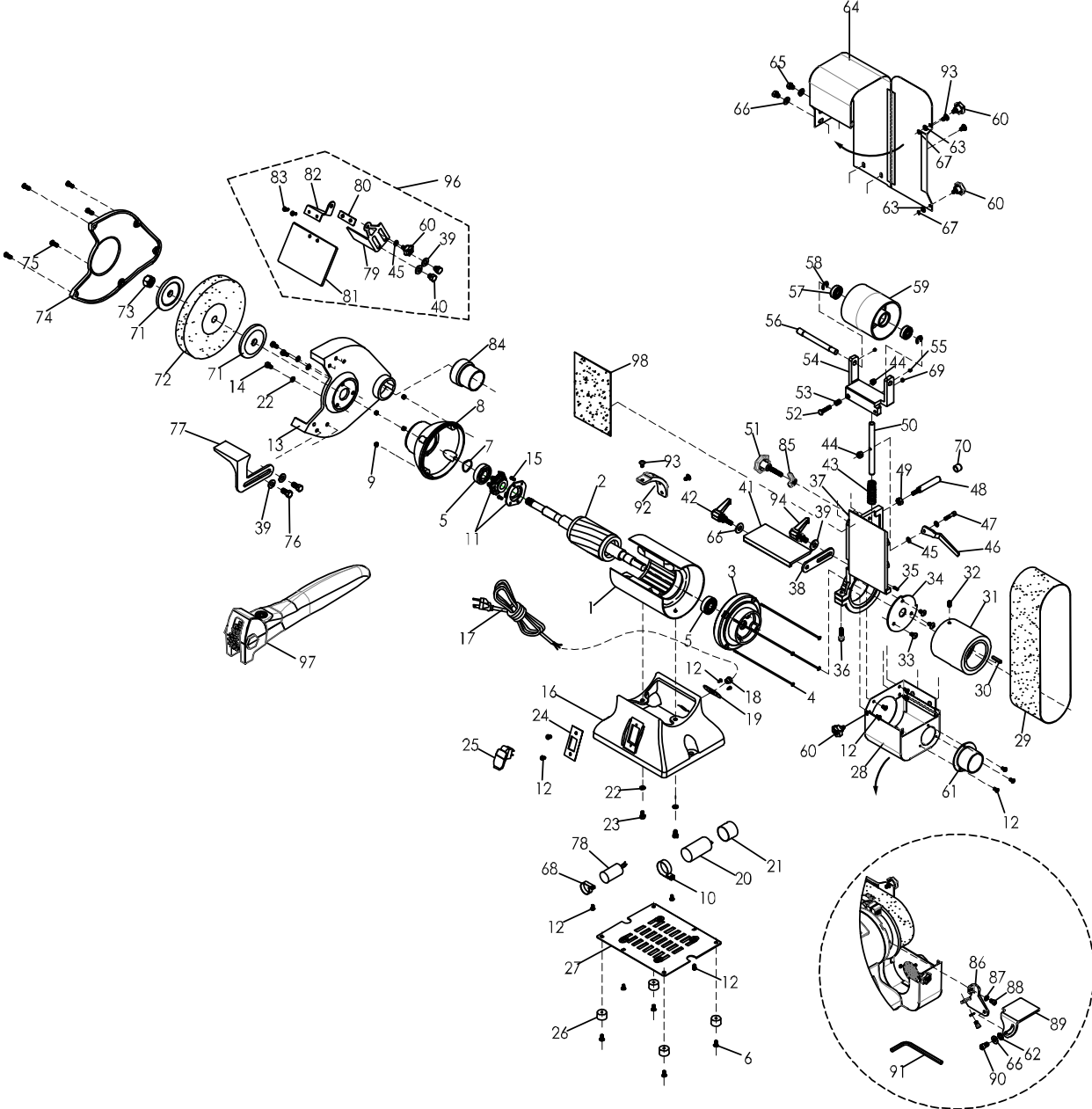

13.3.2 IBGB-436 Sander/Grinder – Parts List

Index No	Part No	Description	Size	Qty
1	IBGB248-01	Motor Housing w/ Stator		1
2	IBGB436-02	Rotor		1
3	IBGB248-03	End Cover		1
4	IBGB248-04	Cross Head Screw	M5 x 210 x 30S	4
5	BB-6204ZZ	Ball Bearing	6204ZZ	2
6	IBG8-36	Truss Head Screw	3/16"-24 x 1/2"	4
7	IBGB248-07	Wave Washer		1
8	IBG8-19	End Bell		1
9	TS-1540031	Hex Nut	M5	4
10	IBG8-05	Capacitor Bracket		1
11	IBG8-41	Centrifugal Switch Assembly		1
12	IBG8-04	Truss Head Screw	3/16"-24 x 3/8"	18
13	IBG8-21	Wheel Guard		1
14	TS-0050021	Hex Cap Screw	1/4"-20 x 5/8"	3
15	IBG8-04	Truss Head Screw	3/16"-24 x 3/8"	2
16	IBG8-10	Base		1
17	IBG8-46	Power Cord		1
18	IBG8-47	Strain Relief		1
19	IBG8-11	Cord Plate		1
20	IBG8-06	Start Capacitor	200MFD, 125VAC	1
21	IBG8-07	Capacitor Cover		1
22	TS-0720071	Lock Washer	1/4"	5
23	TS-0050011	Hex Cap Screw	1/4"-20 x 1/2"	2
24	IBG8-12	Switch Plate		1
25	IBG8-13	Switch with Safety Key		1
	IBG8-13-1	Safety Key (not shown)		1
26	IBG8-02	Rubber Pad		4
27	IBG8-03	Base Plate		1
28	IBGB436-28	Drive Wheel Cover		1
29	IBGB436-29	Sanding Belt	W 4" x L 36", 80 Grit	1
30	IBGB436-30	Key, Dbl Rd Hd	3/16" x 3/16" x 2-9/32"	1
31	IBGB436-31	Drive Wheel	Dia. 4" x W 4"	1
32	TS-0267041	Set Screw	1/4"-20 x 3/8"	1
33	IBGB248-33	Truss Head Screw	1/4"-20 x 3/8"	3
34	IBGB248-34	Positioning Plate		1
35	IBGB248-35	Spring Pin	Dia. 5 x 14	1
36	TS-0208061	Socket Hd Cap Screw	5/16"-18 x 1"	1
37	IBGB436-37	Sanding Belt Bracket		1
38	IBGB248-38	Bracket Plate *		1
39	TS-0680042	Flat Washer *	3/8"	5
40	TS-0060011	Hex Cap Screw	3/8"-16 x 1/2"	2
41	IBGB436-41	Sanding Table		1
42	IBGB248-42	Adjustable Handle *	5/16"-18 x 1"	1
43	IBGB248-43	Spring		1
44	TS-0640071	Nylon Lock Hex Nut	1/4"-20	2
45	TS-0680021	Flat Washer	1/4"	3
46	IBGB248-46	Tension Handle		1
47	TS-0207071	Socket Hd Cap Screw	1/4"-20 x 1-1/4"	1
48	IBGB436-48	Stand-Off	Dia. 13 x L 80	1
49	TS-0561021	Hex Nut	5/16"-18	1
50	IBGB248-50	Support Post		1
51	IBGB248-51	Tracking Adjustment Knob	M8 x 35	1
52	F000114	Round Head Screw	1/4"-20 x 1-1/4"	1
53	IBGB248-53	Spring		1
54	IBGB436-54	Wheel Carrier		1
55	IBGB248-55	Set Screw	3/16"-24 x 1/4"	2
56	IBGB436-56	Shaft		1
57	BB-6201VV	Ball Bearing	6201BR	2
58	6284728	E-Ring	12mm	2
59	IBGB436-59	Driven Wheel	Dia. 4" x W 4"	1

Index No	Part No	Description	Size	Qty
60	IBGB248-60	Knob	1/4"	4
61	IBGB248-61	Dust Port	Dia. 2"	1
62	F002176	External Tooth Lock Washer *	M8	1
63	TS-1550041	Flat Washer	M6	2
64	IBGB436-64	Belt Cover		1
65	6293385	Hex Cap Screw	5/16"-18 x 3/8"	2
66	TS-0680031	Flat Washer *	5/16"	4
67	IBGB248-67	S-Ring	6mm	3
68	IBG8-48	Capacitor Bracket		1
69	TS-0267021	Set Screw	1/4"-20 x 1/4"	1
70	IBGB248-70	Rubber Sleeve		1
71	IBG8-22	Wheel Flange		2
72	IBG8-23	Wheel	#36 Grit, 8" Dia.	1
73	IBG8-24	Hex Nut (Left Hand Thread)	5/8"-11UNC	1
74	IBG8-25	Wheel Cover		1
75	IBG8-26	Truss Head Screw	1/4"-20 x 3/4"	5
76	IBG8-29	Hex Cap Screw	3/8"-16 x 5/8"	2
77	IBG8-27	Tool Rest-Left		1
78	IBG8-49	Running Capacitor	35µF, 250V	1
79	IBG8-32	Spark Guard - Left		1
80	IBG8-35	Eye Shield Plate		1
81	IBG8-33	Eye Shield		1
82	IBG8-34	Eye Shield Bracket - Left		1
83	IBG8-36	Truss Head Screw	3/16"-24 x 1/2"	2
84	IBGB248-84	Dust Port Adapter		1
85	TS-154306	Wing Nut	M8	1
86	IBGB248-86	Bracket Plate		1
87	TS-0720071	Lock Washer	1/4"	2
88	TS-0207021	Socket Hd Cap Screw	1/4"-20 x 1/2"	2
89	IBGB436-89	Tool Rest *		1
90	TS-0208021	Socket Hd Cap Screw *	5/16"-18 x 1/2"	1
91	IBGB248-91	Allen Wrench	6 x L140mm	1
92	IBG8-50	Lamp Fixed Bracket		1
93	IBGB248-33	Truss Head Screw	1/4"-20 x 3/8"	2
94	IBGB248-94	Adjustable Handle *	3/8"-16 x 3/4"	1
96	IBG8-100	Eye Shield Assembly - Left		1
97	IBG8-54	Dresser Assembly		1
98	IBGB436-98	Graphite Sheet		1
	JET-92-73R	JET Logo (not shown)	92 x 38 mm	1
	LM000383	I.D./Warning Label, IBGB-436 (not shown)		1
	IBGB436-HP	Hardware Package *		1

Hardware package includes items marked with asterisk (*).

13.4.1 IBGB-436VS Sander/Grinder – Exploded View

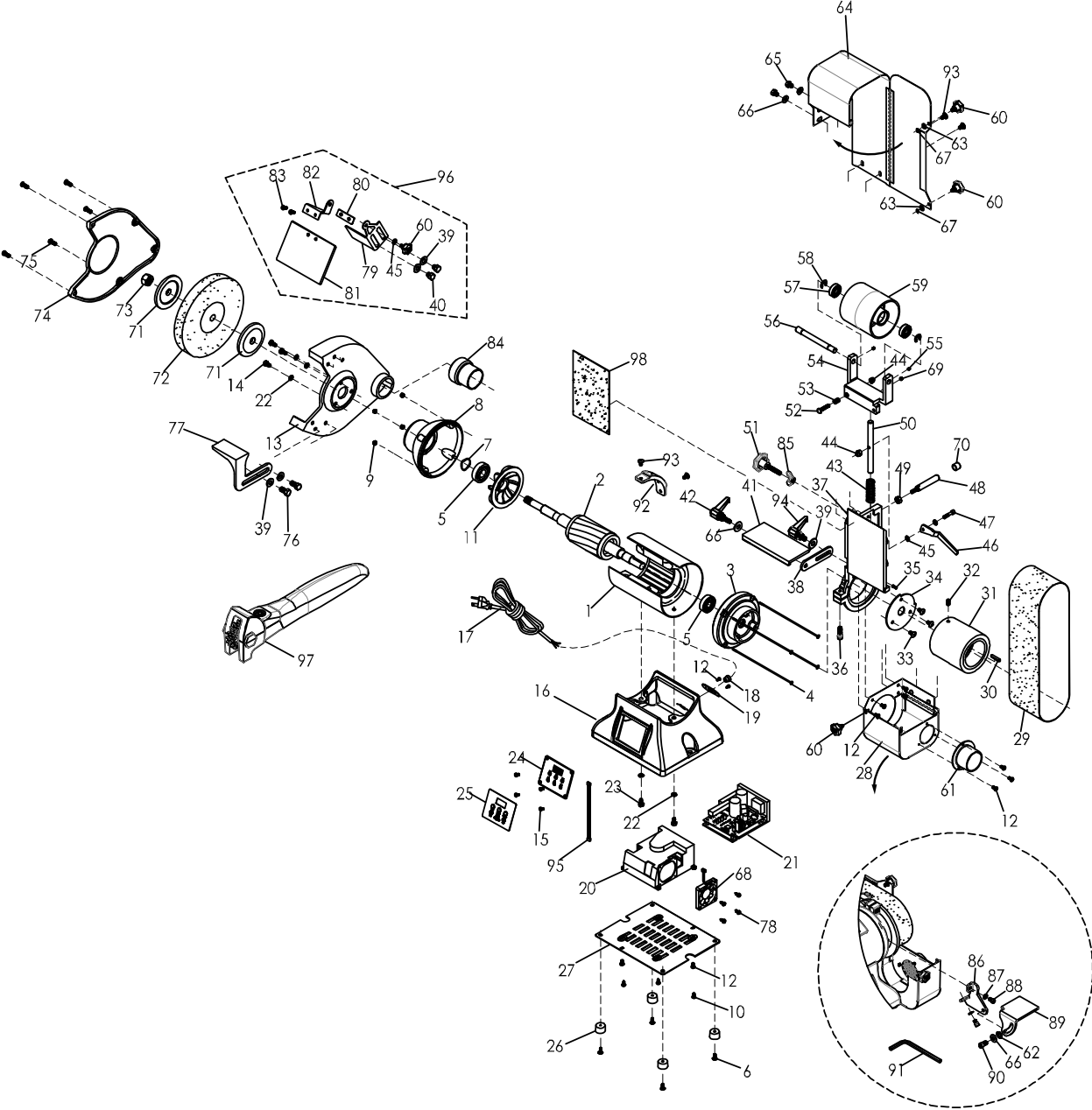

13.4.2 IBGB-436VS Sander/Grinder – Parts List

Index No	Part No	Description	Size	Qty
1	IBGB248VS-01	Motor Housing w/ Stator		1
2	IBGB436VS-02	Rotor		1
3	IBGB248-03	End Cover		1
4	IBGB248-04	Cross Head Screw	M5 x 210 x 30S	4
5	BB-6204ZZ	Ball Bearing	6204ZZ	2
6	IBG8-36	Truss Head Screw	3/16"-24 x 1/2"	4
7	IBGB248-07	Wave Washer		1
8	IBG8-19	End Bell		1
9	TS-1540031	Hex Nut	M5	4
10	990811	Pan Head Tapping Screw	M3.5 x 12	4
11	IBG8-17	Motor Fan		1
12	IBG8-04	Truss Head Screw	3/16"-24 x 3/8"	16
13	IBG8-21	Wheel Guard		1
14	TS-0050021	Hex Cap Screw	1/4"-20 x 5/8"	3
15	6286927	Flat Head Screw	M4 x 10	4
16	IBG8VS-10	Base		1
17	IBG8-46	Power Cord		1
18	IBG8-47	Strain Relief		1
19	IBG8-11	Cord Plate		1
20	IBG8VS-06	Electrical Box		1
21	IBGB248VS-21	Inverter PCB		1
22	TS-0720071	Lock Washer	1/4"	5
23	TS-0050011	Hex Cap Screw	1/4"-20 x 1/2"	2
24	IBGB436VS-24	Control Panel w/ Digital Readout (includes #25)		1
25	IBGB248VS-25	Panel Decal		1
26	IBG8-02	Rubber Pad		4
27	IBG8-03	Base Plate		1
28	IBGB436-28	Drive Wheel Cover		1
29	IBGB436-29	Sanding Belt	W 4" x L 36", 80 Grit	1
30	IBGB436-30	Key	3/16" x 3/16" x 2-9/32"	1
31	IBGB436-31	Drive Wheel	Dia. 4" x W 4"	1
32	TS-0267041	Set Screw	1/4"-20 x 3/8"	1
33	IBGB248-33	Truss Head Screw	1/4"-20 x 3/8"	3
34	IBGB248-34	Positioning Plate		1
35	IBGB248-35	Spring Pin	Dia. 5 x 14	1
36	TS-0208061	Socket Hd Cap Screw	5/16"-18 x 1"	1
37	IBGB436-37	Sanding Belt Bracket		1
38	IBGB248-38	Bracket Plate *		1
39	TS-0680042	Flat Washer *	3/8"	5
40	TS-0060011	Hex Cap Screw	3/8"-16 x 1/2"	2
41	IBGB436-41	Sanding Table		1
42	IBGB248-42	Adjustable Handle *	5/16"-18 x 1"	1
43	IBGB248-43	Spring		1
44	TS-0640071	Nylon Lock Hex Nut	1/4"-20	2
45	TS-0680021	Flat Washer	1/4"	3
46	IBGB248-46	Tension Handle		1
47	TS-0207071	Socket Hd Cap Screw	1/4"-20 x 1-1/4"	1
48	IBGB436-48	Stand-Off	Dia. 13 x L 80	1
49	TS-0561021	Hex Nut	5/16"-18	1
50	IBGB248-50	Support Post		1
51	IBGB248-51	Tracking Adjustment Knob	M8 x 35	1
52	F000114	Round Head Screw	1/4"-20 x 1-1/4"	1
53	IBGB248-53	Spring		1
54	IBGB436-54	Wheel Carrier		1
55	IBGB248-55	Set Screw	3/16"-24 x 1/4"	2
56	IBGB436-56	Shaft		1
57	BB-6201VV	Ball Bearing	6201BR	2
58	6284728	E-Ring	12mm	2
59	IBGB436-59	Driven Wheel	Dia. 4" x W 4"	1
60	IBGB248-60	Knob	1/4"	4

Index No	Part No	Description	Size	Qty
61	IBGB248-61	Dust Port	Dia. 2"	1
62	F002176	External Tooth Lock Washer *	M8	1
63	TS-1550041	Flat Washer	M6	2
64	IBGB436-64	Belt Cover		1
65	6293385	Hex Cap Screw	5/16"-18 x 3/8"	2
66	TS-0680031	Flat Washer *	5/16"	4
67	IBGB248-67	S-Ring	6mm	3
68	IBGB248VS-68	Cooling Fan		1
69	TS-0267021	Set Screw	1/4"-20 x 1/4"	1
70	IBGB248-70	Rubber Sleeve		1
71	IBG8-22	Wheel Flange		2
72	IBG8-23	Wheel	#36 Grit, 8" Dia.	1
73	IBG8-24	Hex Nut (Left Hand Thread)	5/8"-11UNC	1
74	IBG8-25	Wheel Cover		1
75	IBG8-26	Truss Head Screw	1/4"-20 x 3/4"	5
76	IBG8-29	Hex Cap Screw	3/8"-16 x 5/8"	2
77	IBG8-27	Tool Rest-Left		1
78	990811	Pan Head Tapping Screw	M3.5 x 12	4
79	IBG8-32	Spark Guard - Left		1
80	IBG8-35	Eye Shield Plate		1
81	IBG8-33	Eye Shield		1
82	IBG8-34	Eye Shield Bracket - Left		1
83	IBG8-36	Truss Head Screw	3/16"-24 x 1/2"	2
84	IBGB248-84	Dust Port Adapter		1
85	TS-154306	Wing Nut	M8	1
86	IBGB248-86	Bracket Plate		1
87	TS-0720071	Lock Washer	1/4"	2
88	TS-0207021	Socket Hd Cap Screw	1/4"-20 x 1/2"	2
89	IBGB436-89	Tool Rest *		1
90	TS-0208021	Socket Hd Cap Screw *	5/16"-18 x 1/2"	1
91	IBGB248-91	Allen Wrench	6 x L140mm	1
92	IBG8-50	Lamp Fixed Bracket		1
93	IBGB248-33	Truss Head Screw	1/4"-20 x 3/8"	2
94	IBGB248-94	Adjustable Handle *	3/8"-16 x 3/4"	1
95	IBGB248VS-95	Signal Line		1
96	IBG8-100	Eye Shield Assembly - Left		1
97	IBG8-54	Dresser Assembly		1
98	IBGB436-98	Graphite Sheet		1
	JET-92-73R	JET Logo (not shown)	92 x 38 mm	1
	LM000384	I.D./Warning Label, IBGB-436VS (not shown)		1
	IBGB436-HP	Hardware Package *		1

Hardware package includes items marked with asterisk (*).

14.0 Electrical Connections

14.1 Wiring diagram for IBGB-248 and IBGB-436

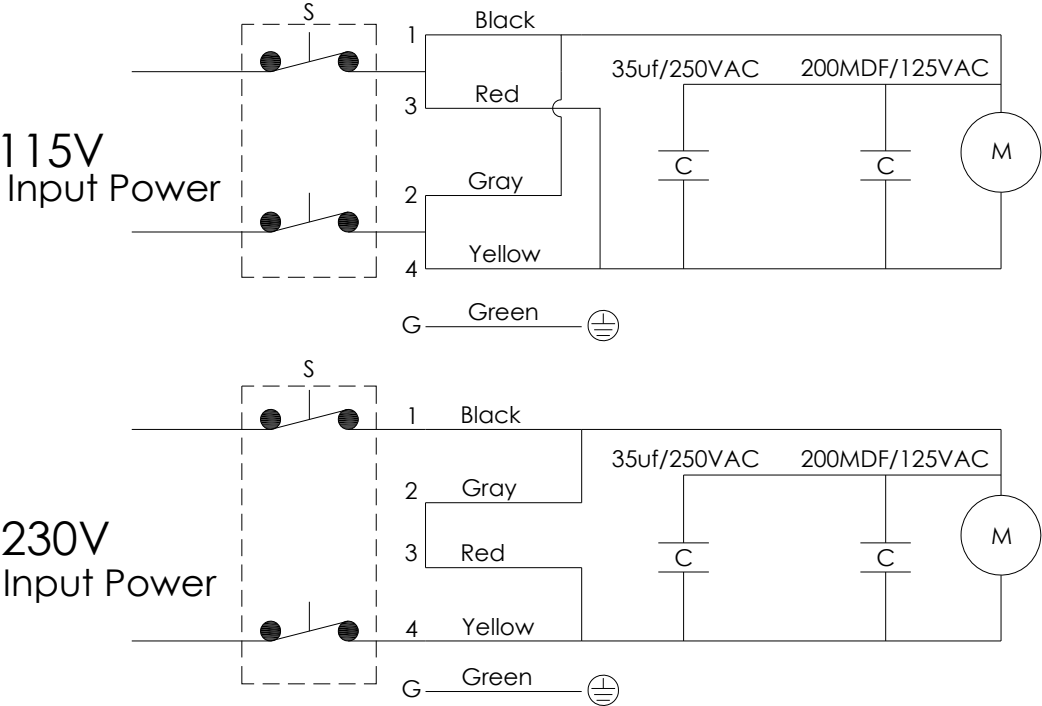

14.2 Wiring diagram for IBGB-248VS and IBGB-436VS

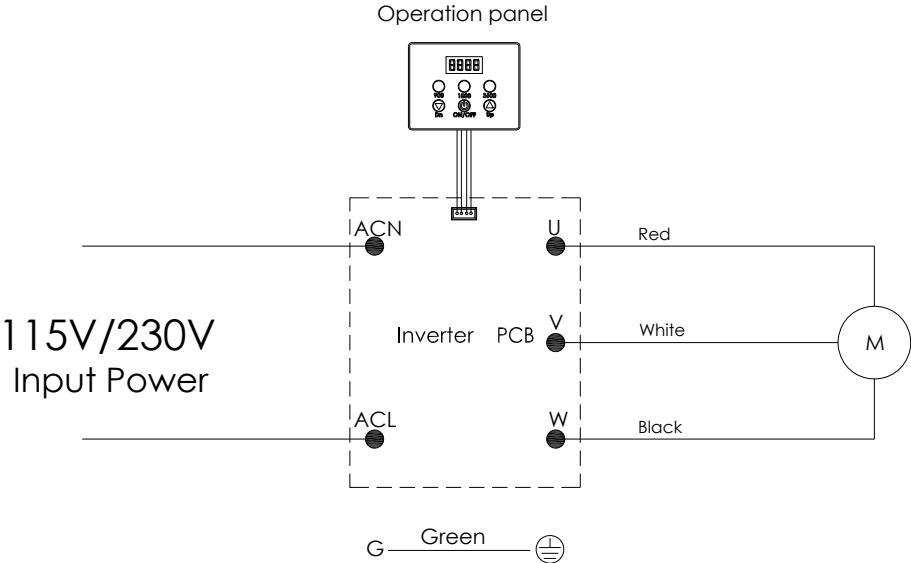

15.0 Warranty and service

JET warrants every product it sells against manufacturers' defects. If one of our tools needs service or repair, please contact Technical Service by calling 1-800-274-6846, 8AM to 5PM CST, Monday through Friday.

Warranty Period

The general warranty lasts for the time period specified in the literature included with your product or on the official JET branded website.

- JET products carry a limited warranty which varies in duration based upon the product. (See chart below)
- Accessories carry a limited warranty of one year from the date of receipt.
- Consumable items are defined as expendable parts or accessories expected to become inoperable within a reasonable amount of use and are covered by a 90 day limited warranty against manufacturer's defects.

Who is Covered

This warranty covers only the initial purchaser of the product from the date of delivery.

What is Covered

This warranty covers any defects in workmanship or materials subject to the limitations stated below. This warranty does not cover failures due directly or indirectly to misuse, abuse, negligence or accidents, normal wear-and-tear, improper repair, alterations or lack of maintenance. JET woodworking machinery is designed to be used with Wood. Use of these machines in the processing of metal, plastics, or other materials outside recommended guidelines may void the warranty. The exceptions are acrylics and other natural items that are made specifically for wood turning.

Warranty Limitations

Woodworking products with a Five Year Warranty that are used for commercial or industrial purposes default to a Two Year Warranty. Please contact Technical Service at 1-800-274-6846 for further clarification.

How to Get Technical Support

Please contact Technical Service by calling 1-800-274-6846. **Please note that you will be asked to provide proof of initial purchase when calling.** If a product requires further inspection, the Technical Service representative will explain and assist with any additional action needed. JET has Authorized Service Centers located throughout the United States. For the name of an Authorized Service Center in your area call 1-800-274-6846 or use the Service Center Locator on the JET website.

More Information

JET is constantly adding new products. For complete, up-to-date product information, check with your local distributor or visit the JET website.

How State Law Applies

This warranty gives you specific legal rights, subject to applicable state law.

Limitations on This Warranty

JET LIMITS ALL IMPLIED WARRANTIES TO THE PERIOD OF THE LIMITED WARRANTY FOR EACH PRODUCT. EXCEPT AS STATED HEREIN, ANY IMPLIED WARRANTIES OF MERCHANTABILITY AND FITNESS FOR A PARTICULAR PURPOSE ARE EXCLUDED. SOME STATES DO NOT ALLOW LIMITATIONS ON HOW LONG AN IMPLIED WARRANTY LASTS, SO THE ABOVE LIMITATION MAY NOT APPLY TO YOU.

JET SHALL IN NO EVENT BE LIABLE FOR DEATH, INJURIES TO PERSONS OR PROPERTY, OR FOR INCIDENTAL, CONTINGENT, SPECIAL, OR CONSEQUENTIAL DAMAGES ARISING FROM THE USE OF OUR PRODUCTS. SOME STATES DO NOT ALLOW THE EXCLUSION OR LIMITATION OF INCIDENTAL OR CONSEQUENTIAL DAMAGES, SO THE ABOVE LIMITATION OR EXCLUSION MAY NOT APPLY TO YOU.

JET sells through distributors only. The specifications listed in JET printed materials and on official JET website are given as general information and are not binding. JET reserves the right to effect at any time, without prior notice, those alterations to parts, fittings, and accessory equipment which they may deem necessary for any reason whatsoever. JET® branded products are not sold in Canada by JPW Industries, Inc.

Product Listing with Warranty Period

90 Days – Parts; Consumable items
1 Year – Motors; Machine Accessories
2 Year – Metalworking Machinery; Electric Hoists, Electric Hoist Accessories; Woodworking Machinery used for industrial or commercial purposes
5 Year – Woodworking Machinery
Limited Lifetime – JET Parallel clamps; VOLT Series Electric Hoists; Manual Hoists; Manual Hoist Accessories; Shop Tools; Warehouse & Dock products; Hand Tools; Air Tools

NOTE: JET is a division of JPW Industries, Inc. References in this document to JET also apply to JPW Industries, Inc., or any of its successors in interest to the JET brand.



427 New Sanford Road
LaVergne, Tennessee 37086
Phone: 800-274-6848
www.jettools.com