



Record purchase information:

Model No.:	Stock No.:
Serial No.:	
Purchased from:	
Date purchased:	

Operating Instructions and Parts Manual

20" EVS Drill Press with Power Feed

Models JDPE-20EVS-PDF, JDPE-20EVSC-PDF



JET
427 New Sanford Road
LaVergne, Tennessee 37086
Ph.: 800-274-6848
www.jettools.com

Part No. M-354250
Edition 1 03/2019
Copyright © 2019 JET



1.0 IMPORTANT SAFETY INSTRUCTIONS

WARNING – To reduce risk of injury:

1.1 General safety rules

1. Read and understand the entire owner's manual before attempting set-up or operation of this machine. Read and understand all warnings posted on the machine.
2. Keep safety guards in place and in working order.
3. Reduce the risk of unintentional starting. Make sure switch is in the OFF position before plugging in the tool.
4. Use the right tool. Do not force a tool or attachment to do a job for which it was not designed.
5. Maintain tools with care. Keep tools sharp and clean for best and safest performance. Follow instructions for lubrication and changing accessories.
6. No attempt shall be made to modify or have makeshift repairs done to the machine. This not only voids the warranty but also may render the machine unsafe.
7. Check for damaged parts. Check for alignment of moving parts, breakage of parts, mounting, and any other condition that may affect the tool's operation. A guard or any part that is damaged should be repaired or replaced.
8. Keep work area clean. Cluttered areas and benches invite accidents.
9. Keep work area well lighted.
10. Keep children and visitors away. All visitors should be kept a safe distance from the work area.
11. Make the workshop child proof. Use padlocks, master switches, and remove starter keys.
12. Wear proper apparel. No loose clothing or jewelry which can get caught in moving parts. Rubber soled footwear is recommended for best footing. Contain long hair.
13. Always wear protective eye wear when operating machinery. Eye wear shall be impact resistant, protective safety glasses with side shields which comply with ANSI Z87.1 specifications. Use of eye wear which does not comply with ANSI Z87.1 specifications could

result in severe injury from breakage of eye protection.

14. Wear ear protectors (plugs or muffs) during extended periods of operation.
15. Do not overreach. Keep proper footing and balance at all times.
16. Do not perform any set-up work while machine is operating.
17. This manual is intended to familiarize you with the technical aspects of this machine. It is not, nor was it intended to be, a training manual.
18. Disconnect tools before servicing and when changing accessories, such as blades, bits, cutters, and the like.
19. Turn off the machine and disconnect from power before cleaning. Use a brush to remove shavings or debris — do not use bare hands.
20. Do not stand on the machine. Serious injury could occur if the machine tips over.
21. Never leave the machine running unattended. Turn the power off and do not leave the machine until moving parts come to a complete stop.
22. Remove adjusting keys and wrenches and unnecessary work pieces from the area before starting the machine.
23. Do not operate the machine in flammable or explosive environments. Do not use in a damp environment or expose to rain.
24. Feed work into a blade or cutter against the direction of rotation of the blade or cutter only.
25. Installation work and electrical wiring must be done by a qualified electrician in accordance with all applicable codes and standards. **Caution:** For circuits which are far away from the electrical service box, the wire size must be increased in order to deliver ample voltage to the motor. To minimize power losses and to prevent motor overheating and burnout, the use of wire sizes for branch circuits or electrical extension cords according to Table 2 (sect. 6.2) is recommended.
26. Use only recommended accessories and follow manufacturer's instructions pertaining to them.
27. Know the tool you are using — its application, limitations, and potential hazards.

1.2 Specific Drill Press safety rules

1. This machine is designed and intended for use by properly trained and experienced personnel only. If you are not familiar with the proper and safe use of a metalworking drill press, do not use this machine until proper training and knowledge have been obtained.

2. Drill press head and table shall be securely locked to the column before operating the drill press. This must always be checked prior to starting the machine.
3. The drill press should be anchored to the floor to prevent sliding or tipping.
4. All work shall be secured using either clamps or a vise to the drill press table. It is unsafe to use your hands to hold any workpiece being drilled.
5. Always use the correct tooling. Tooling shall always be maintained and properly sharpened. All tooling must be run at the proper speeds and feeds as they apply to the job. Use only recommended accessories and follow those manufacturer's instructions pertaining to them. Tooling shall not be forced in to any workpiece but fed according to the proper specifications. Failure to follow these instructions will not only ruin the tooling and possibly the machine, but can cause serious injury.
6. Never brush away chips while the machine is in operation. All cleanup should be done when the machine is stopped.
7. Keep hands in sight. Do not put hands or fingers around, on, or below any rotating cutting tools.
8. Wear proper apparel. Use leather safety gloves when handling any sharp objects or cutting tools. Leather apron and ANSI-approved steel toe shoes are recommended.

9. Avoid contact with coolant or cutting fluids, especially guarding the eyes.

⚠ WARNING: This product can expose you to chemicals including lead which is known to the State of California to cause cancer and birth defects or other reproductive harm, and ethylbenzene which is known to the State of California to cause cancer. For more information go to <http://www.p65warnings.ca.gov>.

⚠ WARNING: Some dust, fumes and gases created by power sanding, sawing, grinding, drilling, welding and other construction activities contain chemicals known to the State of California to cause cancer and birth defects or other reproductive harm. Some examples of these chemicals are:

- lead from lead based paint
- crystalline silica from bricks, cement and other masonry products
- arsenic and chromium from chemically treated lumber

Your risk of exposure varies, depending on how often you do this type of work. To reduce your exposure to these chemicals, work in a well-ventilated area and work with approved safety equipment, such as dust masks that are specifically designed to filter out microscopic particles. For more information go to <http://www.p65warnings.ca.gov/> and <http://www.p65warnings.ca.gov/wood>.

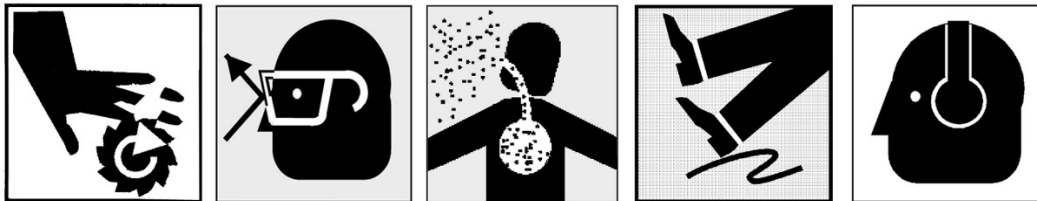

Familiarize yourself with the following safety notices used in this manual:

⚠ CAUTION This means that if precautions are not heeded, it may result in minor injury and/or possible machine damage.

⚠ WARNING This means that if precautions are not heeded, it may result in serious or even fatal injury

SAVE THESE INSTRUCTIONS

2.0 About this manual

This manual is provided by JET, covering the safe operation and maintenance procedures for a JET Model JDPE-20EVS-PDF or JDPE-20EVSC-PDF Drill Press. This manual contains instructions on installation, safety precautions, general operating procedures, maintenance instructions and parts breakdown. Your machine has been designed and constructed to provide consistent, long-term operation if used in accordance with the instructions set forth in this document.

If there are questions or comments, please contact your local supplier or JET. JET can also be reached at our web site: www.jettools.com.

Retain this manual for future reference. If the machine transfers ownership, the manual should accompany it.

 **WARNING Read and understand the entire contents of this manual before attempting assembly or operation. Failure to comply may cause serious injury.**

Register your product using the mail-in card provided, or register online:

<http://www.jettools.com/us/en/service-and-support/warranty/registration/>

3.0 Table of Contents

Section	Page
1.0 IMPORTANT SAFETY INSTRUCTIONS	2
1.1 General safety rules	2
1.2 Specific Drill Press safety rules	2
2.0 About this manual	4
3.0 Table of Contents	5
4.0 Specifications	6
4.1 Mounting hole centers (all models)	7
5.0 Set-Up and Assembly	7
5.1 Shipping contents	7
5.2 Securing base	7
5.3 Assembly	7
5.4 Cleanup	7
6.0 Electrical Connections	7
6.1 GROUNDING INSTRUCTIONS	8
6.2 Extension cords	8
7.0 Adjustments	8
7.1 Table adjustment	8
7.2 Tool installation/removal	9
7.3 Speed range selection	9
7.4 Spindle return spring adjustment	9
8.0 Operation	10
8.1 Precautions	10
8.2 Operating controls	10
8.3 Manual operation	10
8.4 Depth stop	10
8.5 Powerfeed operation	11
8.6 Quill retraction lock	11
8.7 Drilling recommendations	11
9.0 User-maintenance	12
9.1 General maintenance	12
9.2 Additional servicing	12
9.3 Lubrication points	13
10.0 Troubleshooting JDPE-20EVS-PDF series Drill Presses	14
11.0 Replacement Parts	15
11.1.1 JDPE-20EVSC-PDF (Clutch) Head Assembly – Exploded View	16
11.1.2 JDPE-20EVS-PDF (Step Pulley) Head Assembly – Exploded View	17
11.1.3 JDPE-20EVS series Electric Box Assembly – Exploded View	18
11.1.4 JDPE-20EVS series Down Feed Assembly – Exploded View	19
11.1.5 JDPE-20EVS series Column & Table Assembly – Exploded View	20
11.1.6 JDPE-20EVS series Drill Presses – Parts List	21
12.0 Electrical connections – JDPE-20EVS series	26
13.0 Warranty and Service	27

4.0 Specifications

Table 1

Model number	JDPE-20EVS-PDF	JDPE-20EVSC-PDF
Stock number	354250	354251
Machine type	Step pulley model	Clutch model
Motor and Electricals		
Motor type	Totally enclosed, fan cooled, induction	
Horsepower	1.5 HP	
Phase	3 Phase	
Voltage	230 V	
Cycle	60 Hz	
Listed FLA (full load amps)	4.6 A	
Motor speed	1720 RPM	
Motor cord	SJT 4/C, 14AWG 300V	
Inverter rating	2HP 115V 1PH	
Input power requirements	115V, single phase	
Main power cable	SJT 3x14AWG 300V, 6 ft., with plug	
LED Work lamp	12V, 6W; separate power cord SJT 3x18AWG, 6 ft. with 115V plug	
Power transfer	Belt and pulley	
On/Off switch	Magnetic contactor	
Speed range engagement	Step pulley	Clutch
Recommended circuit size ¹	20 A	
Sound emission without load ²	60dB	
Capacities		
Drills to center of circle (Swing)	19-11/16 in. (500 mm)	
Drilling capacity, cast iron	1-1/4 in. (32 mm)	
Drilling capacity, mild steel	1-1/8 in. (28 mm)	
Tapping capacity, cast iron	5/8 in. (16 mm) manually for For/Rev	
Tapping capacity, mild steel	5/8 in. (16 mm) manually for For/Rev	
Spindle to table distance, maximum	32.6 in. (830 mm)	
Spindle to base distance, maximum	46.85 in. (1190 mm)	
Spindle taper	MT3	
Spindle rotation	Forward/reverse	
Quill diameter	2.16 in. (55 mm)	
Number of spindle speeds	Infinitely variable within specified range	
Spindle speed range	50~390, 280~2000 RPM	
Spindle travel	Manual	5 in. (127 mm)
	Auto	4-1/4 in. (107 mm)
Number of power feeds	3	
Power feed range	0.005, 0.007, 0.010 in. (0.12, 0.18, 0.25 mm)	
Table and Column		
Table size LxW	16.5 x 18.5 in. (420 x 470 mm)	
Table working surface LxW	14.96 x 13 in. (380 x 330 mm)	
Number of T-slots	2	
T-slot size WxD	5/8 x 11/16 in.	
T-slot centers	7.5 in. (190.5 mm)	
Table weight capacity	110 lbs. (50 kg)	
Column diameter	4 in. (101.6 mm)	

	JDPE-20EVS-PDF	JDPE-20EVSC-PDF
Base		
Base footprint LxW	17-3/4 x 25-1/2 in. (450 x 650 mm)	
Base working surface LxW	14-3/16 x 13 in. (360 x 330 mm)	
Number of T-slots	2	
T-slot size WxD	5/8 x 11/16 in.	
T-slot centers	7.5 in. (190.5 mm)	
Main materials		
Head	cast iron	
Table and Base	cast iron	
Spindle and Quill	steel	
Column	steel	
Pulley guard	steel	
Dimensions		
Assembled overall dimensions LxWxH	828 x 575 x 1788 mm (32.59 x 22.63 x 70.39 in.)	
Shipping crate dimensions LxWxH	970 x 750 x 1980 mm (38.97 x 29.52 x 77.95 in.)	
Weights		
Net weight	477 lbs. (217 kg)	493 lbs. (224 kg)
Shipping weight	566 lbs. (257 kg)	582 lbs. (264 kg)

¹ Subject to local and national electrical codes.

² The specified values are emission levels and are not necessarily to be seen as safe operating levels. As workplace conditions vary, this information is intended to allow the user to make a better estimation of the hazards and risks involved only.

L = length, W = width, H = height, D = depth

The above specifications were current at the time this manual was published, but because of our policy of continuous improvement, JET reserves the right to change specifications at any time and without prior notice, without incurring obligations.

4.1 Mounting hole centers (all models)

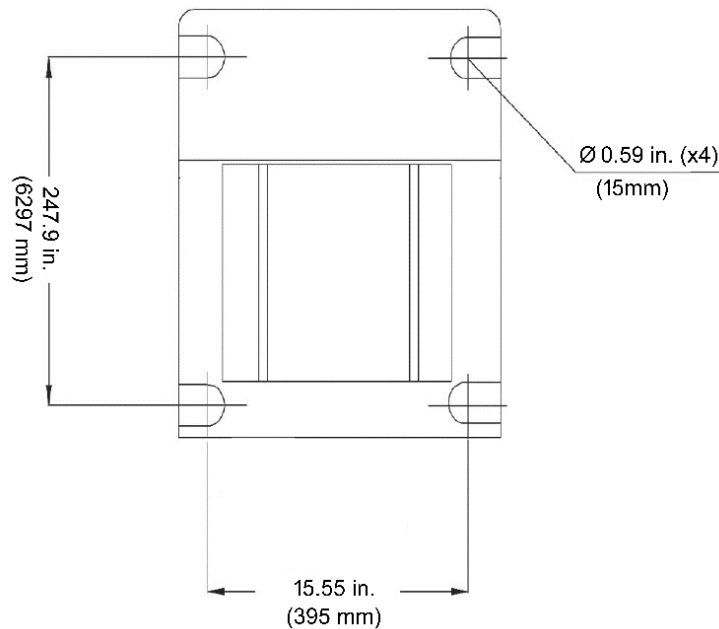

Figure 4-1: Base mounting

⚠WARNING

Read and understand the entire contents of this manual before attempting assembly or operation. Failure to comply may cause serious injury.

5.0 Set-Up and Assembly

5.1 Shipping contents

See Figure 5-1

- 1 Drill Press (not shown)
- 1 Drift key
- 3 Hex wrenches, 3/4/5mm
- 1 Drill chuck arbor MT3-JT6
- 1 Small handle
- 1 Crank handle
- 1 Operating instructions and parts list (not shown)
- 1 Product registration card (not shown)



Figure 5-1

Inspect contents of crate for shipping damage. Report any damage immediately to your distributor and shipping agent. Do not discard any shipping material until drill press is assembled and running properly.

Remove any fasteners holding drill press to pallet. Lift drill press with forklift or hoist with straps. (Note: Lifting point is beneath head and next to column.) Make sure handles, levers, etc. are clear of forks or straps when lifting. **Lifting equipment must be properly rated for weight of drill press.**

Position machine on a solid, level floor, preferably concrete. Area should have good overhead lighting and ventilation. (Refer to OSHA regulations for specific information about using drill presses in industrial environments.) The drill press should be level and rest solidly on floor. Place shims below base as needed to achieve level.

5.2 Securing base

It is strongly recommended that the drill press be secured to floor. The base has four mounting slots; see Figure 4-1. When securing base to floor, apply even torque to the fasteners to prevent distortion of base.

5.3 Assembly

Install crank handle onto worm gear shaft to raise and lower table. See B, Figure 7-1. Secure handle by tightening set screw.

Install smaller handle onto crank handle and tighten nut.

5.4 Cleanup

Exposed metal surfaces have been given a protective coating. Remove this with a soft cloth and a cleaner-degreaser or kerosene. Do not use gasoline, paint thinner or acetone, as these can mar painted surfaces. Do not use an abrasive pad, which may scratch polished surfaces.

Coat all exposed metal surfaces with a light coat of standard SAE20 machine tool oil, to inhibit rust.

6.0 Electrical Connections

⚠WARNING

Electrical connections must be made by a qualified electrician in compliance with all relevant codes. This machine must be properly grounded to help prevent electrical shock and possible fatal injury.

IMPORTANT: The JDPE-20EVS-PDF series Drill Presses operate on **single phase, 115 volt** incoming power.

The drill press uses an inverter (inside control box) to provide infinitely variable spindle speeds within the specified ranges. The inverter controls the speed of the motor by varying the frequency of the voltage supplied to the motor. It converts the 115V single phase input to run the three phase, 230V motor. The inverter has been programmed by the manufacturer; do not attempt to adjust or modify it. If you suspect a problem with the inverter, contact JET technical service.

Before connecting to power source, be sure switch is in *off* position.

It is recommended that the Drill Press be connected to a dedicated 20 amp circuit with circuit breaker or time delay fuse rated "D". **NOTE: Local codes take precedence over recommendations.**

6.1 GROUNDING INSTRUCTIONS

This machine must be grounded. In the event of a malfunction or breakdown, grounding provides a path of least resistance for electric current to reduce the risk of electric shock. This tool is equipped with an electric cord having an equipment-grounding conductor. If a plug is installed, it must be plugged into a matching outlet that is properly installed and grounded in accordance with all local codes and ordinances.

Improper connection of the equipment-grounding conductor can result in a risk of electric shock. The conductor with insulation having an outer surface that is green with or without yellow stripes is the equipment-grounding conductor. If repair or replacement of the electric cord or plug is necessary, do not connect the equipment-grounding conductor to a live terminal.

⚠WARNING Check with a qualified electrician or service personnel if the grounding instructions are not completely understood, or if in doubt as to whether the tool is properly grounded. Failure to comply may cause serious or fatal injury.

Use only 3-wire extension cords that have 3-prong grounding plugs and 3-pole receptacles that accept the tool's plug.

Repair or replace damaged or worn cord immediately.

Grounded, cord-connected tools intended for use on a supply circuit having a nominal rating less than 150 volts:

This tool may be used on a circuit that has an outlet that looks like the one illustrated in **A**, Figure 6-1. The tool is to be used with a grounding plug that looks like the plug illustrated in **A**. Make sure the tool is connected to an outlet having the same configuration as the plug. An adapter, shown in **B**, may be used to connect the plug to a 2-pole receptacle as shown in **B** if a properly grounded outlet is not available. The temporary adapter should be used only until a properly grounded outlet can be installed by a qualified electrician. The green-colored rigid ear, lug, and the like, extending from the adapter must be connected to a permanent ground such as a properly grounded outlet box. **Note:** In Canada, the use of a temporary adaptor is not permitted by the Canadian Electrical Code, C22.1.

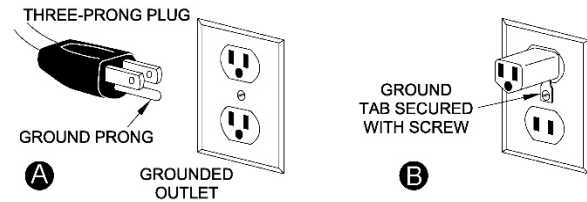

Figure 6-1

6.2 Extension cords

The use of extension cords is discouraged; try to position equipment within reach of the power source. If an extension cord becomes necessary, be sure it is heavy enough to carry the current your product will draw. An undersized cord will cause a drop in line voltage resulting in loss of power and overheating.

Table 2 shows recommended size to use depending on cord length and nameplate ampere rating. If in doubt, use the next heavier gauge. The smaller the gauge number, the heavier the cord.

Ampere Rating		Volts	Total length of cord in feet			
More Than	Not More Than		25	50	100	150
		120	25	50	100	150
		240	50	100	200	300
			AWG			
0	6		18	16	16	14
6	10		18	16	14	12
10	12		16	16	14	12
12	16		14	12	Not Recommended	

Table 2: extension cord recommendations

7.0 Adjustments

7.1 Table adjustment

To raise or lower table, loosen lock handle (A, Figure 7-1) and rotate crank (B). Always tighten lock handle before operations. Note: Lock handle can be repositioned – pull out on handle, rotate, and allow it to resettle on pin.

If drill press base will be used for securing workpiece, loosen lock handle (A) and swing table around column and out of the way, making sure rack follows it without binding. If rack tries to bind, bump rack gently with rubber mallet to free its movement.

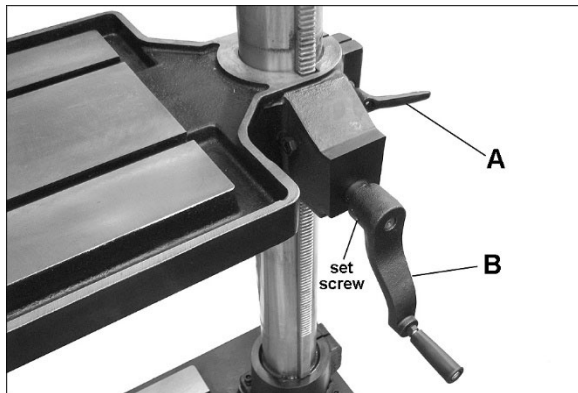

Figure 7-1: table adjustments

7.2 Tool installation/removal

1. Disconnect machine from power source.
2. Thoroughly clean inside of spindle with a soft dry cloth. Also clean any taper or arbor to be used in the spindle. If these are not kept clean, taper or arbor will not “seat” properly in spindle and may drop out unexpectedly.
3. Insert MT3 tool into spindle. If inserting drill chuck arbor, rotate it until tang slides into spindle recess. Tap sharply with rubber mallet to seat tool or drill chuck.

CAUTION Never use a steel-face hammer directly against arbor, tool or spindle.

To remove a tool:

1. Press E-stop button (K, Figure 8-2).
2. Loosen lock handle (A₂, Figure 8-1) on depth scale.
3. Lower quill with feed handle to expose slot in quill.
4. Keep feed handle in lowered position and rotate depth scale (A₁, Figure 8-1) counterclockwise until it comes to a stop.
5. Tighten lock handle (A₂, Figure 8-1). This will keep quill in lowered position.
6. Rotate spindle until slots align through spindle and quill.
7. Insert drift key into slots and tap drift key gently until tool or chuck arbor loosens. Hold tool/chuck with one hand (use glove or rag if needed) to prevent it from falling and being damaged.
8. Loosen lock handle (A₂, Figure 8-1) to release quill.

7.3 Speed range selection

7.3.1 JDPE-20EVS (step pulley model)

1. Disconnect machine from power source.
2. Release latch (M, Figure 8-1) to de-tension belt. Work motor belt out of pulley grooves and into other set of grooves. Figure 7-2 shows speed range belt positions. Make sure belts are properly seated in the grooves of each pulley.
3. Re-tension belts by securing latch (M).
4. Close pulley guard before operating machine.

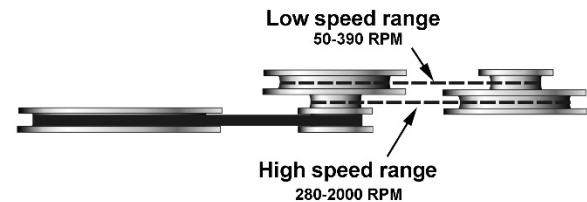

Figure 7-2 (step pulley model JDPE-20EVS-PDF)

7.3.2 JDPE-20EVSC (clutch model)

Move shift lever (C, Figure 8-2) while spindle is turning to select high or low speed range.

7.4 Spindle return spring adjustment

The tension of the return spring, which raises the spindle after drilling, has been pre-set by the manufacturer. No further adjustment should be attempted unless absolutely necessary. Should spindle retraction weaken after long-term use of the drill press, tighten the spring tension as follows.

1. Grasp spring cover (A, Figure 7-3) firmly with one hand. Loosen screw (B) just enough to rotate spring cover past pin (C) and settle it on the next notch. *DO NOT remove spring cap or allow it to rotate freely in your hand*, or spring may unwind.
2. Rotate spring cover clockwise to decrease spring tension; counter-clockwise to increase spring tension.
3. Re-tighten screw (B).

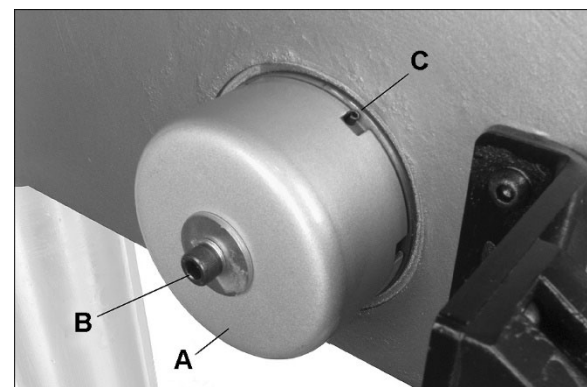

Figure 7-3

8.0 Operation

8.1 Precautions

The following precautions must be observed in order to avoid harm to operator or damage to drill press or tool. In addition, read and understand all safety warnings in sect. 1.0.

1. Work table must be locked to column so it will not be forced down the column by the thrust of the drilling process.
2. Be sure belt is tensioned.
3. Do NOT start to drill workpiece until making certain workpiece is secured on table.
4. Point of operation protection is required for maximum safety. This remains responsibility of the user since conditions differ between jobs.
5. Make sure the tool is secured in spindle or chuck before attempting to use the drill press.
6. Make sure spindle taper is clean and free of burrs, scoring, and galling to assure maximum gripping.
7. When drilling through-holes, use a block of wood or metal below the workpiece to prevent drilling into table.
8. Apply sufficient cutting fluid to point of tool contact, using a spray bottle or other flow system (not provided).

8.2 Operating controls

Refer to Figures 8-1 and 8-2.

Depth stop and scale. Turn scale ring (A_1) until desired depth aligns with indicator. Tighten lock handle (A_2). If not using depth stop, loosen lock handle (A_2).

Downfeed handles (B).

Manual model: Counterclockwise movement advances quill toward table. When released, return spring retracts quill. CAUTION: Handle will spring back if released, and rotate during retraction.

Powerfeed: Pulling downfeed handles outward (away from head) engages powerfeed.

Speed Range Lever (C). *Clutch model only.* Move lever to change speed. (Absent from step pulley model, where speed range is set by changing pulley position.)

Downfeed dial (D). Select among three feed rates. Set dial to "0" when not using powerfeed.

Powerfeed locking knob (E). Tighten to prevent powerfeed engagement. Loosen to allow downfeed handles (B) to be pushed outward into powerfeed mode.

Digital readout (F). Shows spindle RPM (revolutions per minute).

Spindle rotation switch (G). Selects spindle rotation direction. Use reverse to retract a tap or for left-hand thread tapping.

Spindle speed control (H). Sets spindle rotation speed within the pre-selected range.

Spindle start/stop (J). Activates spindle rotation.

Emergency stop (K). Push to stop all machine functions. To restart, rotate E-stop button clockwise until it disengages. Note: It is recommended that start/stop button (N) be used for normal spindle stoppage to prevent unnecessary wear on E-stop.

Work lamp (L). Uses separate power cord. Turn on/off using switch atop lamp.

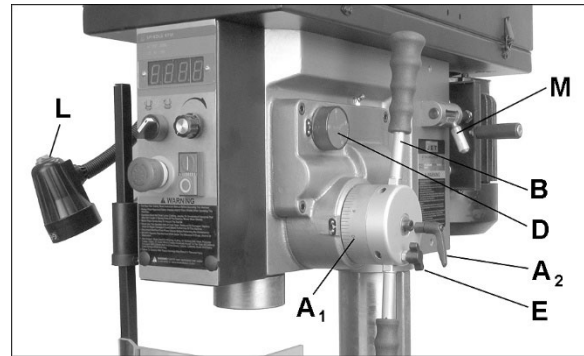

Figure 8-1: head right side (JDPE-20EVSC-PDF)

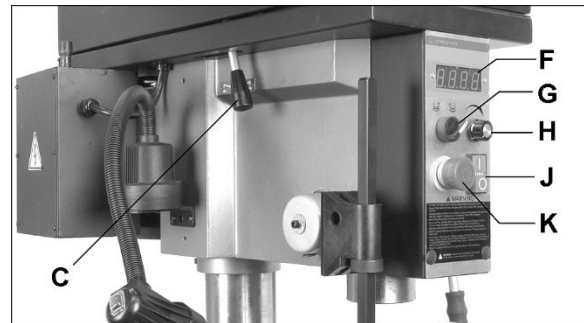

Figure 8-2: head left side (JDPE-20EVSC-PDF)

8.3 Manual operation

1. Tighten powerfeed locking knob (E, Figure 8-1) to prevent powerfeed activation.
2. Use feed handles (B, Figure 8-1) to bring tool down into workpiece.

8.4 Depth stop

The depth stop is used for repetitive drilling of holes of identical depth in manual mode, or to set the drill depth and engage bit retraction in powerfeed mode.

1. Turn OFF drill press.
2. Mark desired depth of cut on workpiece as reference.

3. Rotate scale *counterclockwise* all the way until it stops at "0".
4. Loosen lock handle (A₂).
5. Use feed handle (B, Figure 8-1) to lower bit to desired depth based on reference mark.
6. Hold feed handle in position, and tighten lock handle (A₂).
7. The bit will now stop at the marked depth when feed handle is rotated.
8. To release depth stop, loosen lock handle (A₂).

8.5 Powerfeed operation

See Figures 8-1 and 8-2.

1. Select appropriate spindle speed range (lever C on clutch model; reposition belt on step pulley model).
2. Select downfeed rate (D).
3. Set depth of cut (*sect. 8.4*).
4. Tighten handle (A₂) to secure setting.
5. Loosen powerfeed locking knob (E).
6. Turn on spindle and adjust speed knob (H) to desired RPM.
7. Pull feed handle (B) outward (away from head) to engage powerfeed.
8. Once downfeed has reached pre-set depth, the trip will release and spindle will retract.
9. To stop feed before cycle has ended, push feed handle (B) toward head.

NOTE: Set downfeed dial (D) to "0" when not using powerfeed.

8.6 Quill retraction lock

The quill can be held in the down position and prevented from retracting, to facilitate removal of chuck arbor or for cleaning.

1. Loosen lock handle (A₂, Figure 8-1).
2. Rotate feed handle (B) to lower spindle to point at which it is to be locked, and hold feed handle stationary in this position.
3. Rotate scale (A₁) *clockwise* all the way until it stops.
4. Tighten lock handle (A₂). You can now release downfeed handle. The quill will remain in this lowered position until released.
5. To release quill, loosen lock handle (A₂).

8.7 Drilling recommendations

The following are only general recommendations. Consult a machinery handbook or contact the

specific tool manufacturer for more detailed information.

8.7.1 Drilling speeds

The speed of a drill is usually measured in terms of the rate at which the outer periphery of the tool moves in relation to the work being drilled. The common term for this is Surface Feet per Minute (SFM). The relationship of SFM is expressed in the following formulas:

$$\text{SFM} = 0.26 \times \text{rpm} \times \text{Drill Diameter (in inches)}$$

$$\text{RPM} = 3.8 \times \frac{\text{SFM}}{\text{Drill diameter (in inches)}}$$

In general, the higher the speed the shorter the drill life. Operating at the low end of the speed range for a particular material will result in longer life. The most efficient speed for drill operation depends upon many variables:

1. Composition and hardness of material.
2. Depth of hole.
3. Efficiency of cutting fluid.
4. Type and condition of drilling machine.
5. Desired quality of hole.
6. Difficulty of set-up.

8.7.2 Drilling feed

The feed of a drill is governed by size of tool and the material drilled. Because feed rate partially determines rate of production and also is a factor in tool life, it should be chosen carefully for each job. In general, the most effective feeds will be found in the following ranges:

Diameter of Drill (inches)	Feed per Revolution (inches)
Under 1/8	0.001 to 0.002
1/8 to 1/4	0.002 to 0.004
1/4 to 1/2	0.004 to 0.007
1/2 to 5/8	0.007 to 0.015

Table 2

8.7.3 Excessive speed/feed indicators

A drill that splits up the web is evidence of too much feed or insufficient tip clearance at the center as a result of improper grinding. The rapid wearing away of the extreme outer corners of cutting edges indicates that speed is too high. A drill chipping or breaking out at the cutting edges indicates that either feed is too heavy or drill has been ground with too much tip clearance.

8.7.4 Speeds for high speed steel drills

Material	Speed (SFPM)
Alloy Steel — 300 to 400 Brinell	20-30
Stainless Steel	30-40
Automotive Steel Forgings	40-50
Tool Steel, 1.2C	50-60
Steel, .4C to .5C	70-80
Mild Machinery Steel, .2C to .3C	80-110
Hard Chilled Cast Iron	30-40
Medium Hard Cast Iron	70-100
Soft Cast Iron	100-150
Malleable Iron	80-90
High Nickel Steel or Monel	40-50
High Tensile Bronze	70-150
Ordinary Brass and Bronze	200-300
Aluminum and its Alloys	200-300
Magnesium and its Alloys	250-400
Slate, Marble, and Stone	15-25
Plastics and similar materials (Bakelite)	100-150
Wood	300-400
Titanium Alloys	10-25
Titanium Alloy Sheet	50-60
Note: In cases where carbon steel drills are applicable, the drill should be run at speeds of 40 to 50 percent of those given above.	

Table 3

9.0 User-maintenance

9.1 General maintenance

1. After each use, wipe down the machine with a clean rag and apply a light coat of oil to exposed metal surfaces to inhibit rust.
2. Confirm that machine is properly lubricated. See sect. 9.3.
3. Keep table and T-slots clean and free of debris. Use a brush to clear shavings, not bare hands.
4. Periodically use compressed air or vacuum to clear any dust off motor fan. Use a vacuum to clear dust from cooling fan grill on control box.
5. Periodically check power cords to inverter, motor, lamp, etc. If any damage is found replace the cord immediately.
6. If drill press will not be used for an extended period, release latch (M, Figure 8-1) to reduce stress on belts.

9.2 Additional servicing

Any additional servicing should be performed by authorized service personnel.

9.3 Lubrication points

Regularly scheduled maintenance is crucial to ensure a long service life for your machine. The following are recommendations and may vary based upon frequency of use. Note: Ball bearings are pre-lubricated and sealed, and require no further attention. **Disconnect machine from power before lubricating.**

Refer to Figures 9-1 and 9-2.

Table 4

	Location	Action	Lubricant	Frequency
1	Splines on spindle	Lower spindle and insert grease into hole atop pulley; raise and lower spindle to distribute	NLGI #2 lithium tube grease	Monthly
2	Quill and column	Wipe down and apply light coat of oil	SAE 20 Machine tool oil	Periodically
3	Rack	Clean with kerosene and apply oil.	SAE 20 Machine tool oil	Weekly
4	Gearbox	Insert into grease fitting using grease gun	Mobil DTE® Oil Heavy Medium, or equivalent	Daily
5	Quill return spring (see Figure 8-3)	Apply oil beneath spring housing using squirt can	SAE 20 Machine tool oil	Annually

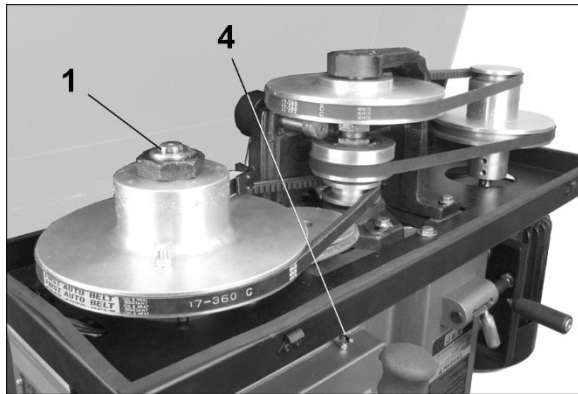

Figure 9-1

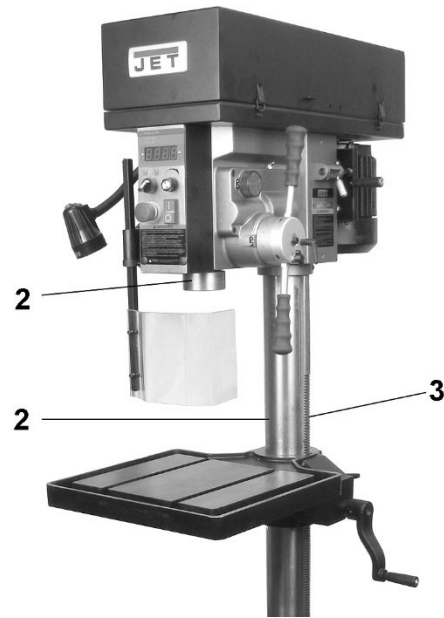

Figure 9-2

10.0 Troubleshooting JDPE-20EVS-PDF series Drill Presses

Symptom	Possible Cause	Correction *
Drill Press will not start.	E-stop still engaged.	Release E-stop by rotating button clockwise.
	Disconnected from power.	Check plug connection. Check if branch circuit breaker has been tripped, or fuse blown. Reset breaker or replace fuse.
	Damaged power cord or plug.	Replace cord and plug.
	Motor overheated, tripping thermal relay.	Allow motor to cool, then restart.
	Open wire in switch circuit.	Repair open circuit.
	Defective switch.	Replace switch.
	Broken drive belt(s).	Replace drive belt(s).
Motor runs, but spindle does not turn.	Belts not tensioned.	Engage latch to tension belts.
	Broken belt.	Replace belt.
	Open wire in switch circuit.	Repair open circuit.
	Defective switch.	Replace switch.
Drill does not come up to speed, or stalls.	Excessive feed rate for size of drill and material being drilled. No cutting fluid or improper cutting fluid.	Reduce feed pressure or use correct cutting fluid.
	Insufficient power due to extension cord	Replace with adequate size and length cord. Optimally, locate machine near power source.
	Worn drive belt.	Check condition of belt. Replace if glazed or slipping on pulleys.
	Low current.	Contact a qualified electrician.
Excessive noise or vibration while operating.	Base on uneven surface.	Adjust machine so that it rests evenly on floor.
	Belt not tensioned properly.	Adjust belt tension.
	Faulty belt(s).	Replace belts.
	Dry spindle.	Lubricate spindle splines and quill.
	Loose spindle pulley.	Check tightness of retaining nut on pulley.
	Loose motor pulley.	Tighten setscrews in pulley.
	Worn or damaged spindle bearings.	Replace bearings.
Poorly drilled holes.	Damaged splines.	Replace spindle.
	Drill is dull, or improperly ground	Sharpen drill. Check for proper angles and reliefs. Regrind to proper geometry.
	Lack of rigidity in hold-down method.	Check that all T-slot hold-downs and the table-lock are tight.
	Speed too fast for material and drill size.	Check spindle speed recommendations. Reduce speed if necessary.
	Feed too fast for material and drill size.	Reduce feed rate.
Motor overheating.	No or improper cutting fluid being used.	Use proper cutting fluid for material being drilled.
	Electrical circuit fault.	Check current draw in circuit. Make sure current draw is the same as rating on motor plate.
	Oversize drill.	Reduce drill size.
	Excessive feed.	Reduce feed rate.
Table cannot be raised.	No cutting fluid, or wrong fluid.	Use correct cutting fluid for the material and drill.
Table cannot be raised.	Lack of lubrication.	Make sure that rack, column and crank handle worm gear are properly cleaned and lubricated.
	No speed readout.	Adjust gap between speed sensor and spindle pulley bolts to approximately 1/16". If there is no readout on the LED speed indicator after adjusting the gap, replace the sensor.

Excessive drill bit runout, or wobble.	Bent drill bit.	Replace bit.
	Bit, or chuck not properly installed.	Reinstall bit, or chuck properly.
	Worn spindle bearings.	Replace spindle bearings.
Spindle will not retract.	Return spring out of adjustment or damaged.	Adjust or replace as needed.
Spindle retracts too slowly or too quickly.	Improper return spring tension.	Adjust spring tension.

*** WARNING: Some corrections may require a qualified electrician.**

Table 5

11.0 Replacement Parts

Replacement parts are listed on the following pages. To order parts or reach our service department, call 1-800-274-6848, Monday through Friday, 8:00 a.m. to 5:00 p.m. CST. Having the Model Number and Serial Number of your machine available when you call will allow us to serve you quickly and accurately.

Non-proprietary parts, such as fasteners, can be found at local hardware stores, or may be ordered from JET.

Some parts are shown for reference only, and may not be available individually.

11.1.1 JDPE-20EVSC-PDF (Clutch) Head Assembly – Exploded View

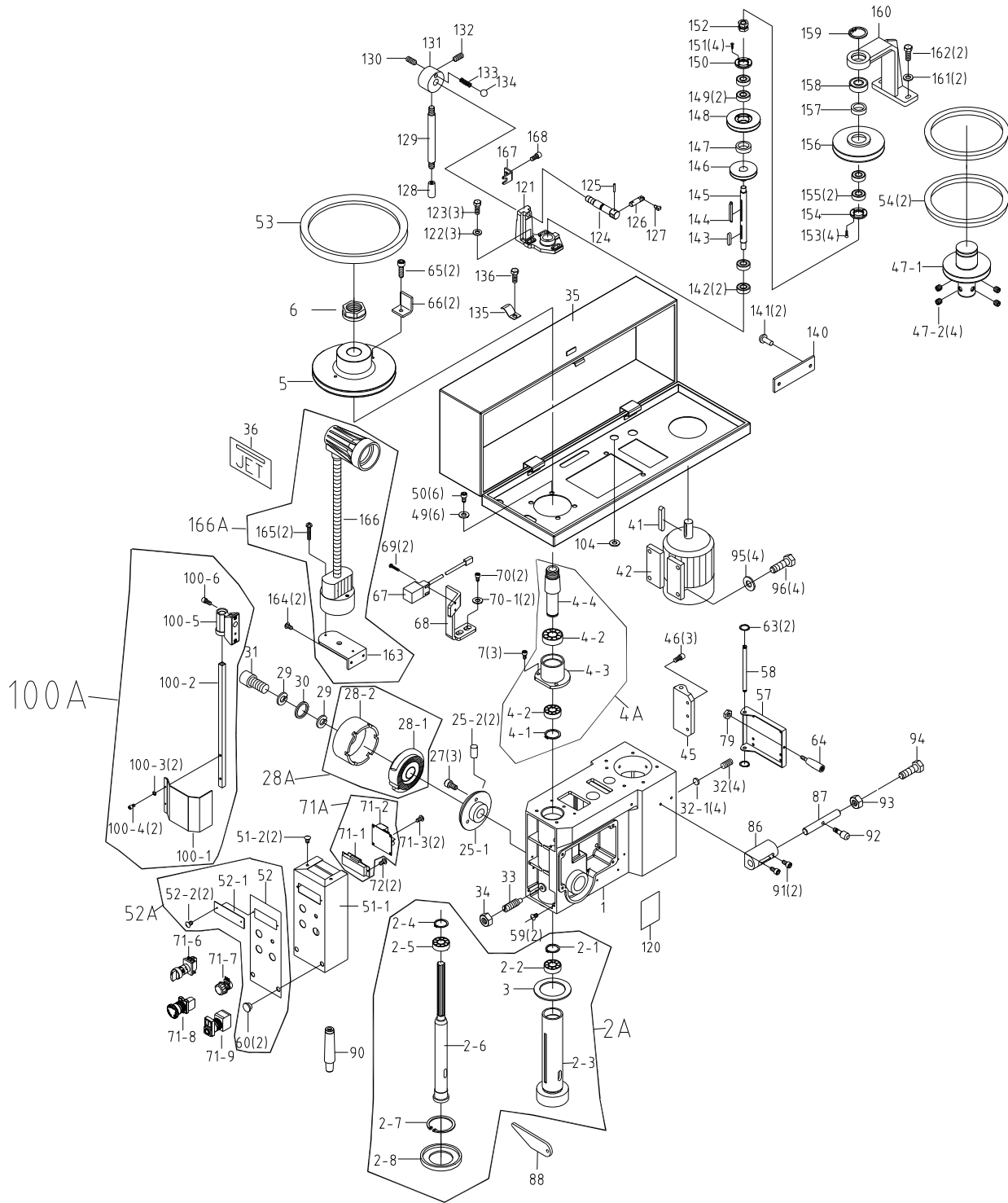

11.1.2 JDPE-20EVS-PDF (Step Pulley) Head Assembly – Exploded View

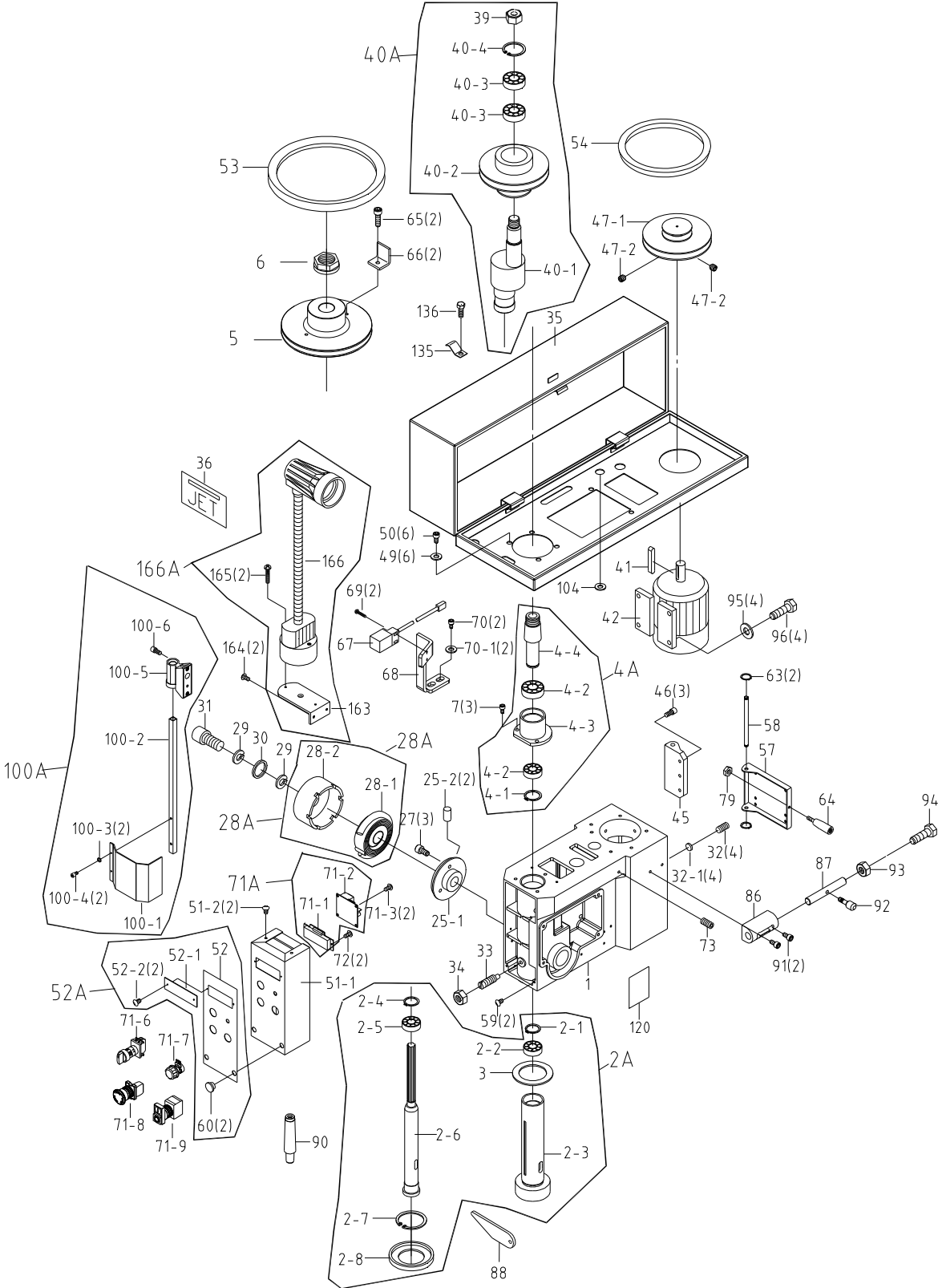

11.1.3 JDPE-20EVS series Electric Box Assembly – Exploded View

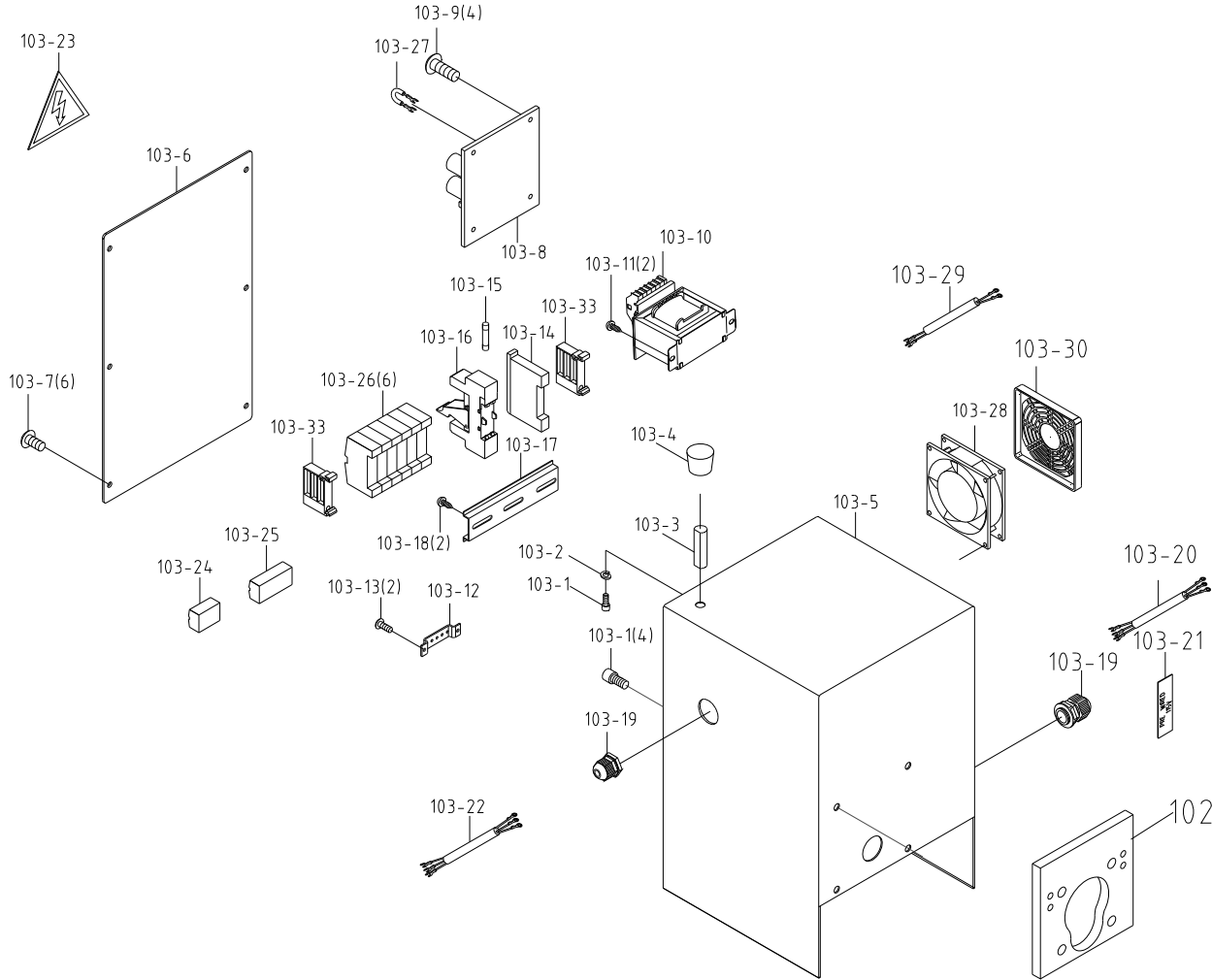

11.1.4 JDPE-20EVS series Down Feed Assembly – Exploded View

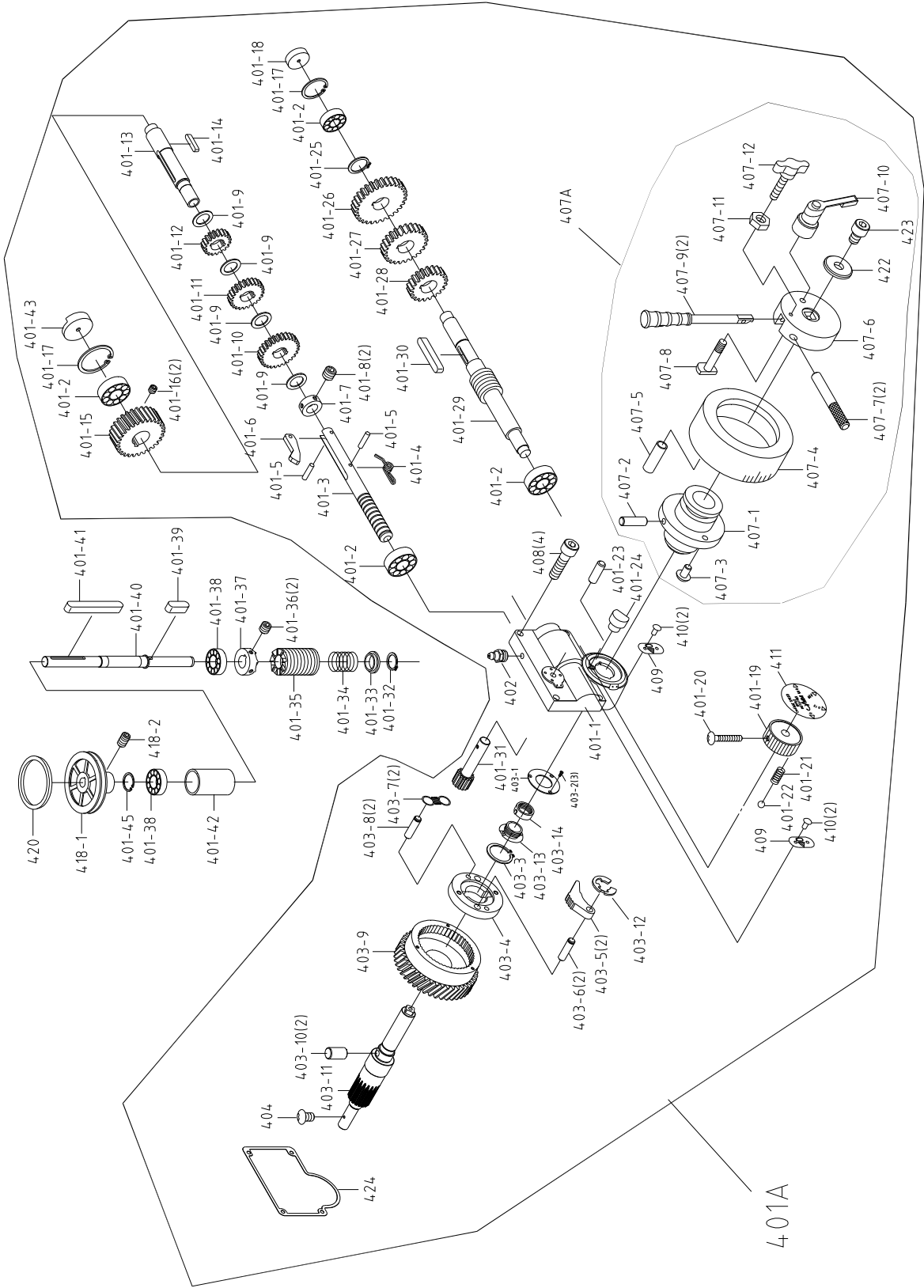

11.1.5 JDPE-20EVS series Column & Table Assembly – Exploded View

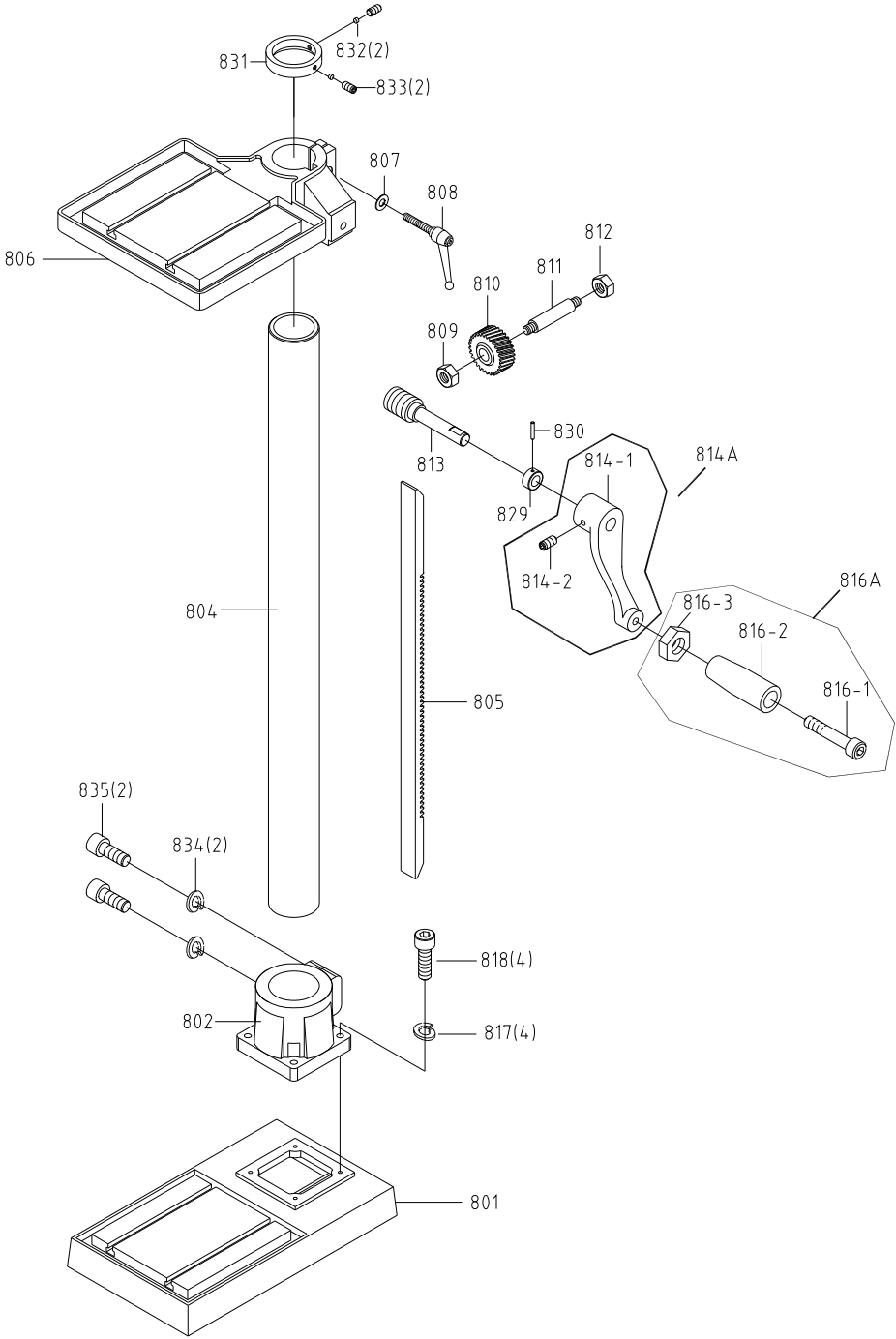

11.1.6 JDPE-20EVS series Drill Presses – Parts List

Index No.	Part No.	Description	Size	Qty
1	JDPE20EVS-PDF-01	Headstock Casting		1
2A	JDPE20EVS-PDF-2A	Quill Assembly (#2-1~2-8, 3)		1
2-1	HBS56MVS-096-10	C-Retaining Ring, Ext	S20	1
2-2	BB-6204ZZ	Ball Bearing	6204ZZ	1
2-3	JDPE20EVS-PDF-2-3	Quill	MT3	1
2-4	MBS-1211-150	C-Retaining Ring, Ext	S35	1
2-5	BB-6207ZZ	Ball Bearing	6207ZZ	1
2-6	JDPE20EVS-PDF-2-6	Spindle	MT3	1
2-7	F006095	C-Retaining Ring, Int	R72	1
2-8	JDPE20EVS-PDF-2-8	Bearing Bottom Cover	MT3	1
3	JDPE20EVS-PDF-3	Rubber Cushion		1
4A	JDPE20EVS-PDF-4A	Spindle Taper Sleeve Assembly		1
4-1	EPR2-85	C-Retaining Ring, Ext	S30	1
4-2	BB-6006ZZ	Ball Bearing	6006ZZ	2
4-3	JDPE20EVS-PDF-4-3	Bearing Bracket		1
4-4	JDPE20EVS-PDF-4-4	Spindle Taper Sleeve		1
5	JDPE20EVS-PDF-5	Spindle Pulley		1
6	JDPE20EVS-PDF-6	Spindle Lock Nut		1
7	TS-1504041	Socket Hd Cap Screw	M8-1.25x20L	3
25-1	JDPE20EVS-PDF-25-1	Spring Base Assembly		1
25-2	B-119	Spring Pin	Ø3x12L mm	2
27	TS-1533052	Pan Head Screw	M5-0.8x15L	3
28A	JDPE20EVS-PDF-28A	Spring Cover w/ Spring Assembly (#28-1~28-2)		1
28-1	JDPE20EVS-PDF-28-1	Spring		1
28-2	JDPE20EVS-PDF-28-2	Spring Cover		1
29	TS-2361061	Lock Washer	M6	2
30	TS-1550041	Flat Washer	M6	1
31	TS-1503041	Socket Hd Cap Screw	M6-1.0x15L	1
32	TS-1524011	Set Screw	M8-1.25x8L	4
32-1	JDPE20EVS-PDF-32-1	Bushing		4
33	JDPE20EVS-PDF-33	Fillister Head Screw		1
34	TS-1540071	Hex Nut	M10	1
35	JDPE20EVS-PDF-35	Pulley Guard Assembly		1
36	JET-138	JET Logo	138x57mm	1
39	JDPE20EVS-PDF-39	Hex Nut (Step Pulley only)	5/8"	1
40A	JDPE20EVS-PDF-40A	Idle Pulley Shaft Assembly (#39~40-4) (Step Pulley only)		1
40-1	JDPE20EVS-PDF-40-1	Idle Pulley Shaft (Step Pulley only)		1
40-2	JDPE20EVS-PDF-40-2	Idle Pulley (Step Pulley only)		1
40-3	BB-6204ZZ	Ball Bearing (Step Pulley only)	6204ZZ	2
40-4	20EVS-T44-1	C-Retaining Ring, Int (Step Pulley only)	R47	1
41	2210-260	Double Rd Hd Key	6x6x40L mm	1
42	JDPE20EVS-PDF-42	Motor	1.5HP/220V/60HZ/3PH	1
45	JDPE20EVS-PDF-45	Motor Bracket		1
46	TS-1504041	Socket Hd Cap Screw	M8-1.25x20L	3
47-1	JDPE20EVS-PDF-47-1	Motor Pulley		1
47-2	TS-0270031	Set Screw	5/16"-18x3/8"L	4
49	TS-1550061	Flat Washer	M8x18xt1.5mm	6
50	TS-1504031	Socket Hd Cap Screw	M8-1.25x15L	6
51-1	JDPE20EVS-PDF-51-1	Control Panel Box		1
51-2	5512222	Pan Head Screw	M6-1.0x15L	2
52A	JDPE20EVS-PDF-52A	Control Panel Assembly (#52, 52-1, 52-2, 60)		1
52	JDPE20EVS-PDF-52	Control Panel		1
52-1	JDPE20EVS-PDF-52-1	Acrylic Plate		1
52-2	JWL1221VS-128	Pan Head Screw	M3-0.5x5L	2
53	JDPE20EVS-PDF-53	Gear Belt	17-360C	1
54	JDPE20EVSC-PDF-17380C	Gear Belt (Clutch only)	17-380C	2
	JDPE20EVS-PDF-53	Gear Belt (Step Pulley only)	17-360C	1
57	JDPE20EVS-PDF-57	Motor Support Bracket		1
58	JDPE20EVS-PDF-58	Motor Bracket Shaft		1

Index No.	Part No.	Description	Size	Qty
59	TS-2246102	Socket Hd Button Screw	M6-1.0x10L	2
60	JDPE20EVS-PDF-60	Plastic Plug	Ø12	2
63	GHD20PF-97	C-Retaining Ring, Ext	S12	2
64	JDPE20EVS-PDF-64	Motor Bracket Handle		1
65	TS-1503041	Socket Hd Cap Screw	M6-1.0x15L	2
66	JDPE20EVS-PDF-66	Sensor Board		2
67	JDPE20EVS-PDF-67	Sensor		1
68	JDPE20EVS-PDF-68	Sensor Bracket		1
69	F001159	Pan Head Screw	M3-0.5x16L	2
70	TS-1503041	Socket Hd Cap Screw	M6-1.0x15L	2
70-1	JDPE20EVS-PDF-70-1	Flat Washer	Ø6.5xØ13xt0.8mm	2
71A	JDPE20EVS-PDF-71A	Digital Readout Assembly (#71-1,71-2)		1
71-1	JDPE20EVS-PDF-71-1	Digital Display		1
71-2	JDPE20EVS-PDF-71-2	PCB For Digital Display		1
71-3	TS-1534041	Pan Head Screw	M5-0.8x10L	2
71-6	JDPE20EVS-PDF-71-6	Forward/ Reverse Switch		1
71-7	JDPE20EVS-PDF-71-7	Speed Control Switch w/ Knob Assembly		1
71-8	JDPE20EVS-PDF-71-8	EMG Stop Switch		1
71-9	JDPE20EVS-PDF-71-9	Start/ Stop Switch		1
72	TS-1531012	Pan Head Screw	M3-0.5x6L	4
73	JWBS14DP-4-3	Set Screw (Step Pulley only)	M8-1.25x35L	1
79	TS-1540061	Hex Nut	M8	1
86	JDPE20EVS-PDF-86	Latch Seat		1
87	JDPE20EVS-PDF-87	Latch		1
88	JDPE20EVS-PDF-88	Drift Key		1
89	JDPE20EVS-PDF-1/2JT6	Drill Chuck with Key	1/2"-JT6	1
90	JDPE20EVS-PDF-MT3JT6	Drill Chuck Arbor	MT3-JT6	1
91	TS-1503041	Socket Hd Cap Screw	M6-1.0x15L	2
92	JDPE20EVS-PDF-92	Latch Handle		1
93	TS-1540071	Hex Nut	M10-1.5	1
94	TS-1491031	Hex Cap Screw	M10-1.5x25L	1
95	TS-0680031	Flat Washer	5/16"x18xt1.5mm	4
96	TS-1490031	Hex Cap Screw	M8-1.25x20L	4
100A	JDPE20EVS-PDF-100A	Spindle Guard Assembly (#101~106)		1
100-1	JDPE20EVS-PDF-100-1	Spindle Guard		1
100-2	JDPE20EVS-PDF-100-2	Support Rod		1
100-3	TS-2361051	Lock Washer	M5	2
100-4	TS-1502021	Socket Hd Cap Screw	M5-0.8x10L	2
100-5	JDPE20EVS-PDF-100-5	Rotary Seat		1
100-6	TS-1502041	Socket Hd Cap Screw	M5-0.8x15L	2
102	JDPE20EVS-PDF-102	Plate		1
103A	JDPE20EVS-PDF-103ACSA	Electric Box Complete Assembly (#103-1~103-30)	CSA version	1
	JDPE20EVS-PDF-103A	Electric Box Complete Assembly (#103-1~103-23 and 103-25~103-27)	Non-CSA version	1
103-1	TS-1503041	Socket Hd Cap Screw	M6-1.0x15L	5
103-2	TS-2361061	Lock Washer	M6	1
103-3	JDPE20EVS-PDF-103-3	Stand-Off		1
103-4	JDPE20EVS-PDF-103-4	Rubber Stop		1
103-5	JDPE20EVS-PDF-103-5	Electric Box		1
103-6	JDPE20EVS-PDF-103-6	Electric Box Cover		1
103-7	TS-1532032	Pan Head Screw	M4-0.7x10L	6
103-8	JDPE20EVS-PDF-103-8	Inverter	2HP 115V	1
103-9	TS-1532032	Pan Head Screw	M4-0.7x10L	4
103-10	JDPE20EVS-PDF-103-10	Transformer		1
103-11	TS-1532032	Pan Head Screw	M4-0.7x10L	2
103-12	JDPE20EVS-PDF-103-12	Grounding Copper Plate		1
103-13	TS-1532032	Pan Head Screw	M4-0.7x10L	2
103-14	JDPE20EVS-PDF-103-14	Fuse Seat	281-661	1
103-15	JDPE20EVS-PDF-103-2A	Fuse	2A2CM	1
	JDPE20EVS-PDF-103-2ACSA	Fuse (CSA)	2A2CM/CSA	1
103-16	JDPE20EVS-PDF-103-16	Relay		1

Index No.	Part No.	Description	Size	Qty
103-17	JDPE20EVS-PDF-103-17	Aluminum Rail	56MM	1
103-18	TS-1532032	Pan Head Screw	M4-0.7x10L	2
103-19	JDPE20EVS-PDF-103-19	Strain Relief	PG13.5	2
103-20	JDPE20EVS-PDF-103-20	Power Cord with Plug	SJT 3x14AWG 300V	1
103-21	LM000378	Voltage Decal		1
103-22	JDPE20EVS-PDF-103-22	Control Cable		1
103-23	CL-HV	Label - Voltage Hazard		1
103-24	JDPE20EVS-PDF-103-24	Quick Plug (2P)		2
103-25	JDPE20EVS-PDF-103-25	Quick Plug (3P)		2
103-26	JDPE20EVS-PDF-103-26	Terminal		6
103-27	JDPE20EVS-PDF-103-27	Shortage Plate		3
103-28	JDPE20EVS-PDF-103-28	Cooling Fan		1
103-29	JDPE20EVS-PDF-103-29	Control Cable		1
103-30	JDPE20EVS-PDF-103-30	Cooling Fan Grill		1
103-33	JDPE20EVS-PDF-103-33	Terminal Support Plate		1
104	JDPE20EVS-PDF-104	Snap Bushing	NB1419	1
120	LM000379	ID Label, JDPE-20EVS-PDF		1
	LM000380	ID Label, JDPE-20EVSC-PDF		1
121	JDPE20EVSC-PDF-121	Bearing Bracket (Clutch Only)		1
122	TS-1550061	Flat Washer (Clutch Only)	M8x18x1.6t	3
123	TS-1490051	Hex Cap Screw (Clutch Only)	M8-1.25x30L	3
124	JDPE20EVSC-PDF-124	Control Bar (Clutch Only)		1
125	B-56	Spring Pin (Clutch Only)	Ø3x20L mm	1
126	JDPE20EVSC-PDF-126	Crank Rod (Clutch Only)		1
127	JDPE20EVSC-PDF-127	Crank (Clutch Only)		1
128	JDPE20EVSC-PDF-128	Knob (Clutch Only)		1
129	JDPE20EVSC-PDF-129	Handle (Clutch Only)		1
130	TS-0270031	Set Screw (Clutch Only)	3/8"-16x3/8"L	1
131	JDPE20EVSC-PDF-131	Hi/Low Speed Setting Block (Clutch Only)		1
132	TS-0267052	Set Screw (Clutch Only)	1/4"-20x1/2"L	1
133	JDPE20EVSC-PDF-133	Spring (Clutch Only)		1
134	SB-8MM	Steel Ball (Clutch Only)	Ø8 or 5/16"	1
135	JDPE20EVS-PDF-135	Cable Clip		1
136	TS-0051051	Hex Cap Screw	5/16"-18x1"L	1
140	JDPE20EVSC-PDF-140	Hi/Low Speed Label (Clutch Only)		1
141	JDPE20EVSC-PDF-141	Rivet (Clutch Only)	Ø2x4L mm	1
142	BB-6202ZZ	Ball Bearing (Clutch Only)	6202ZZ	2
143	KF2R5525	Double Round Hd Key (Clutch Only)	5x5x25L mm	1
144	JDPE20EVSC-PDF-144	Key (Clutch Only)	5x5x53L mm	1
145	JDPE20EVSC-PDF-145	Pulley Shaft (Clutch Only)		1
146	JDPE20EVSC-PDF-146	Pulley (Clutch Only)		1
147	JDPE20EVSC-PDF-147	Spacer (Clutch Only)		1
148	JDPE20EVSC-PDF-148	Pulley (Clutch Only)		1
149	BB-6203ZZ	Ball Bearing (Clutch Only)	SKF6203ZZ	2
150	JDPE20EVSC-PDF-150	Fixes Bracket (Clutch Only)		1
151	TS-1512031	Socket Hd Flat Screw (Clutch Only)	M4-0.7x15L	4
152	JDPE20EVS-PDF-152	Crank Support (Clutch Only)		1
153	TS-1512031	Socket Hd Flat Screw (Clutch Only)	M4-0.7x15L	4
154	JDPE20EVSC-PDF-154	Fixed Bracket (Clutch Only)		1
155	BB-6203ZZ	Ball Bearing (Clutch Only)	SKF6203ZZ	2
156	JDPE20EVSC-PDF-156	Pulley (Clutch Only)		1
157	JDPE20EVSC-PDF-157	Spacer (Clutch Only)		1
158	JDPE20EVSC-PDF-158	Ball Bearing (Clutch Only)	6202ZZ	1
159	JDPE20EVSC-PDF-R35	C-Ring (Clutch Only)	R35	1
160	JDPE20EVSC-PDF-160	Idler Pulley Support (Clutch Only)		1
161	TS-1550061	Flat Washer (Clutch Only)	M8x18xt1.5mm	2
162	TS-1490041	Hex Cap Screw (Clutch Only)	M8-1.25x25L	2
163	GHD20-126	Lamp Base		1
164	TS-1503031	Socket Hd Cap Screw	M6-1.0x12L	2
165	TS-2284352	Pan Head Screw	M4-0.7x35L	2
166	MD40GH-123	Led Lamp	110V	1
166A	JDPE20EVS-PDF-LEDA	Led Assembly (#163,165,166)	115V with Plug	1

Index No.	Part No.	Description	Size	Qty
167	JDPE20EVS-PDF-167	Cable Clip		1
168	TS-1482011	Hex Cap Screw	M6-1.0x10L	1
401A	JDPE20EVS-PDF-401A	Power Down Feed Compound Assembly		1
401-1	JDPE20EVS-PDF-401-1	Gear Box		1
401-2	BB-6003ZZ	Ball Bearing	6003ZZ	4
401-3	2450082A	Speed Change Lever		1
401-4	2450084A	Spring Leaf		1
401-5	GHD20PF-357	Spring Pin	Ø3x10L mm	2
401-6	2450083A	Stop Key		1
401-7	2450089A	Fixed Bushing		1
401-8	TS-1523011	Set Screw	M6-1.0x6L	2
401-9	2450074A	Washer		4
401-10	2450072A	Gear	M2x28T	1
401-11	2450071A	Gear	M2x24T	1
401-12	2450070A	Gear	M2x19T	1
401-13	2450073A	Shaft		1
401-14	GHD20PF-379	Double Rd Hd.Key	5x5x28L mm	1
401-15	2450008	Worm Gear	M1.75x25T	1
401-16	TS-1523011	Set Screw	M6-1.0x6L	2
401-17	F006033	C-Retaining Ring, Int.	R33	2
401-18	668129	Plug		1
401-19	2450079	Speed Dial		1
401-20	GHD20PF-233	Pan Head Screw	M4-0.7x25L	1
401-21	290089	Spring		1
401-22	SB-8MM	Steel Ball	Ø8mm	1
401-23	2450051	Pin		1
401-24	2450020	Release Block		1
401-25	GHD20PF-380	C-Retaining Ring, Int.	S19	1
401-26	2450077A	Gear	M2x30T	1
401-27	2450076A	Gear	M2x25T	1
401-28	2450075A	Gear	M2x21T	1
401-29	JDPE20EVS-PDF-401-29	Transfer Worm Shaft		1
401-30	GHD20PF-265	Double Rd. Hd. Key	5x5x32L mm	1
401-31	2450081A	Gear Shaft		1
401-32	GHD20-148	C-Retaining Ring, Ext	S15	1
401-33	JDPE20EVS-PDF-401-33	Washer		1
401-34	2450054	Spring		1
401-35	2450052	Worm Shaft		1
401-36	TS-1523011	Set Screw	M6-1.0x6L	2
401-37	2450053	Clutch Block		1
401-38	BB-6003ZZ	Ball Bearing	6003ZZ	2
401-39	GHD20PF-296	Key Double Rd Hd	5x5x10L mm	1
401-40	JDPE20EVS-PDF-401-40	Transfer Shaft		1
401-41	S0400545	Key Double Rd Hd	5x5x45L mm	1
401-42	JDPE20EVS-PDF-401-42	Bushing		1
401-43	JDPE20EVS-PDF-401-43	Cover		1
401-45	GHD20-10	C-Retaining Ring, Ext	S17	1
402	JDPE20EVS-PDF-402	Grease Fitting	1/8"x45°	1
403-1	JDPE20EVS-PDF-403-1	Cover		1
403-2	F001230	Pan Head Screw	M4-0.7x4L	3
403-3	GHD20PF-244	C-Retaining Ring, Ext	S25	1
403-4	2450024	Clutch Key Base		1
403-5	2450026	Clutch Key		2
403-6	2450097	Clutch Key Pin	Ø7x23L mm	2
403-7	2450028	Spring		2
403-8	2450027	Spring Pin		2
403-9	2450023	Worm Gear		1
403-10	2450022A	Cylindrical Key		2
403-11	JDPE20EVS-PDF-403-11	Pinion Shaft		1
403-12	GHD20PF-376	E-Retainer Ring	E5	1
403-13	2450096	Clutch Screw		1
403-14	2450095	Clutch Nut		1

Index No.	Part No.	Description	Size	Qty
404	GHD20PF-40	Screw	3/16"-18x3/8"L	1
407A	JDPE20EVS-PDF-407A	Clutch Handle Assembly (#407-1~407-12,422,423)	Inch	1
407-1	2450087A	Clutch Bushing		1
407-2	2450030	Bushing Pin		1
407-3	2450031	Bushing Stop		1
407-4	2450032	Scale Base	Inch	1
407-5	GHD20PF-332	Pin	Ø5x15L mm	1
407-6	2450037	Handle Hub		1
407-7	2450039	Handle Rod Pin		2
407-8	2450033	Scale Base Set Screw		1
407-9	2450038N	Handle Rod		2
407-10	2450063	Handle		1
407-11	TS-0640081	Hex Nut	5/16"	1
407-12	GHD20PF-346	Manual Feed Knob	5/16"-18x3/4"L	1
408	TS-1504101	Socket Hd Cap Screw	M8-1.25x50L	4
409	2450060	Pointer		2
410	GHD20PF-249	Rivet	Ø2x4L mm	4
411	GHD20PF-370	Speed Scale	Inch	1
418-1	JDPE20EVS-PDF-418-1	Power Feed Transfer Pulley		1
418-2	TS-1524011	Set Screw	M8-1.25x8L	2
420	JDPE20EVS-PDF-420	Rubber Tubular Belt	Ø8x565 mm	1
422	TS-0680031	Flat Washer	5/16"x23x2t	1
423	TS-1504021	Socket Hd Cap Screw	M8x12L	1
424	JDPE20EVS-PDF-424	Gasket		1
801	JDPE20EVS-PDF-801	Base		1
802	JDPE20EVS-PDF-802	Column Base		1
804	JDPE20EVS-PDF-804	Column		1
805	JDPE20EVS-PDF-805	Rack		1
806	JDPE20EVS-PDF-806	Table		1
807	TS-2360121	Flat Washer	M12	1
808	JDPE20EVS-PDF-808	Lever Handle		1
809	TS-1540081	Hex Nut	M12	1
810	JDPE20EVS-PDF-810	Worm Gear		1
811	JDPE20EVS-PDF-811	Worm Gear Shaft		1
812	TS-1540081	Hex Nut	M12	1
813	JDPE20EVS-PDF-813	Worm Rod		1
814A	JDPE20EVS-PDF-814A	Crank Assembly (#814-1,814-2)		1
814-1	JDPE20EVS-PDF-814-1	Crank		1
814-2	TS-0271051	Set Screw	3/8"-16x1/2"	1
816A	JDPE20EVS-PDF-816A	Handle Assembly (#816-1~816-3)		1
816-1	JDPE20EVS-PDF-816-1	Screw	3/8"-16UNCx3-1/2"	1
816-2	JDPE20EVS-PDF-816-2	Handle		1
816-3	TS-0561031	Hex Nut	3/8"	1
817	TS-2361121	Lock Washer	M12	4
818	TS-1506091	Socket Hd Cap Screw	M12-1.75x60L	4
829	JDPE20EVS-PDF-829	Spacer		1
830	HBS814GH-020	Spring Pin	Ø5x34L mm	1
831	JDPE20EVS-PDF-831	Column Flange Ring		1
832	JDPE20EVS-PDF-832	Bushing		2
833	TS-1525011	Set Screw	M10-1.5x10	2
834	TS-2361161	Lock Washer	M16	2
835	F005494	Socket Hd Cap Screw	M16-2.0x50	2
	TS-152706	Hex Wrench	4MM	1
	TS-152705	Hex Wrench	5MM	1
	TS-152704	Hex Wrench	3MM	1

12.0 Electrical connections – JDPE-20EVS series

JDPE-20EVS-PDF/ JDPE-20EVSC-PDF wiring diagram

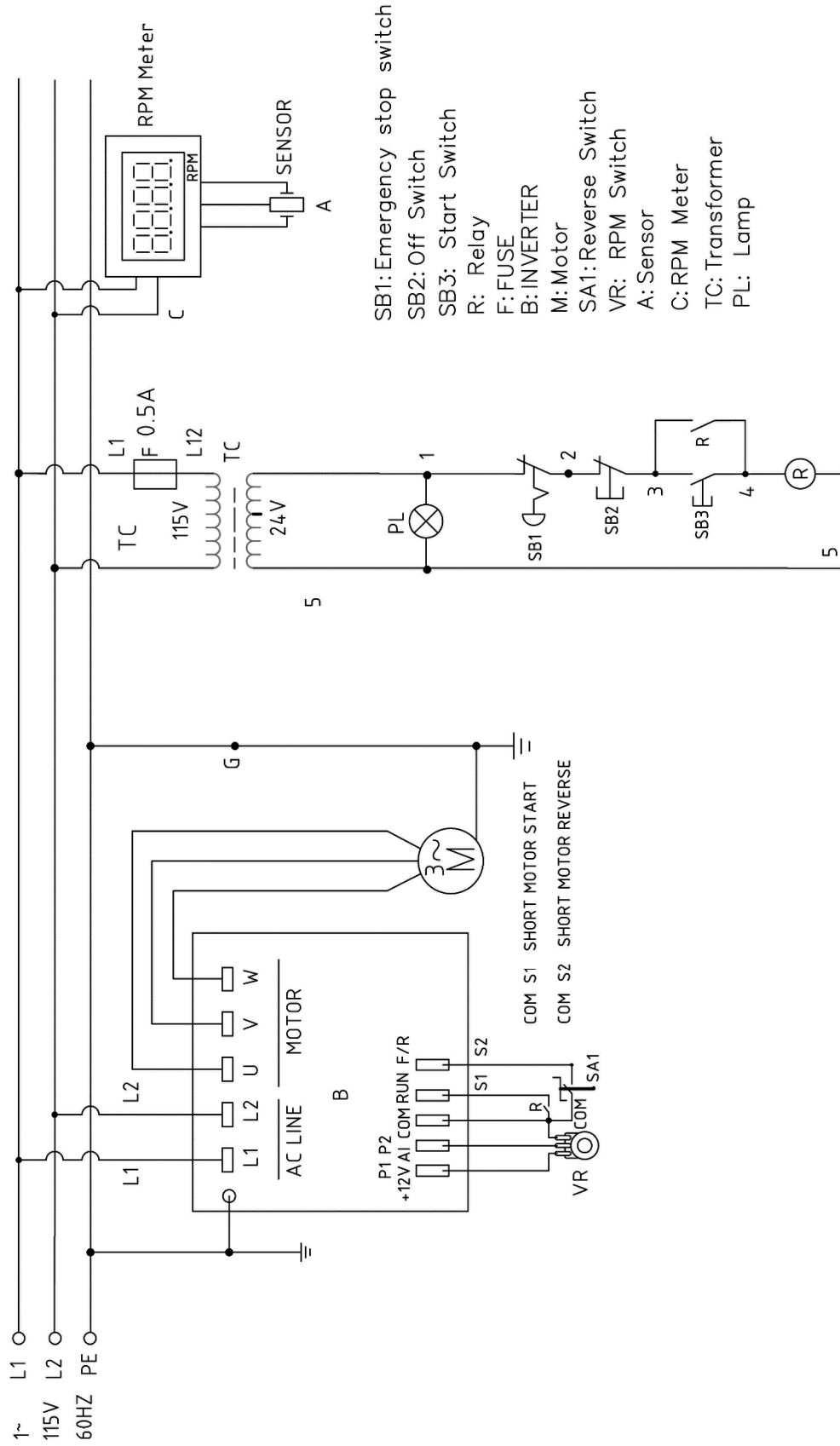

13.0 Warranty and Service

JET warrants every product it sells against manufacturers' defects. If one of our tools needs service or repair, please contact Technical Service by calling 1-800-274-6846, 8AM to 5PM CST, Monday through Friday.

Warranty Period

The general warranty lasts for the time period specified in the literature included with your product or on the official JET branded website.

- JET products carry a limited warranty which varies in duration based upon the product. (See chart below)
- Accessories carry a limited warranty of one year from the date of receipt.
- Consumable items are defined as expendable parts or accessories expected to become inoperable within a reasonable amount of use and are covered by a 90 day limited warranty against manufacturer's defects.

Who is Covered

This warranty covers only the initial purchaser of the product from the date of delivery.

What is Covered

This warranty covers any defects in workmanship or materials subject to the limitations stated below. This warranty does not cover failures due directly or indirectly to misuse, abuse, negligence or accidents, normal wear-and-tear, improper repair, alterations or lack of maintenance. JET woodworking machinery is designed to be used with Wood. Use of these machines in the processing of metal, plastics, or other materials outside recommended guidelines may void the warranty. The exceptions are acrylics and other natural items that are made specifically for wood turning.

Warranty Limitations

Woodworking products with a Five Year Warranty that are used for commercial or industrial purposes default to a Two Year Warranty. Please contact Technical Service at 1-800-274-6846 for further clarification.

How to Get Technical Support

Please contact Technical Service by calling 1-800-274-6846. **Please note that you will be asked to provide proof of initial purchase when calling.** If a product requires further inspection, the Technical Service representative will explain and assist with any additional action needed. JET has Authorized Service Centers located throughout the United States. For the name of an Authorized Service Center in your area call 1-800-274-6846 or use the Service Center Locator on the JET website.

More Information

JET is constantly adding new products. For complete, up-to-date product information, check with your local distributor or visit the JET website.

How State Law Applies

This warranty gives you specific legal rights, subject to applicable state law.

Limitations on This Warranty

JET LIMITS ALL IMPLIED WARRANTIES TO THE PERIOD OF THE LIMITED WARRANTY FOR EACH PRODUCT. EXCEPT AS STATED HEREIN, ANY IMPLIED WARRANTIES OF MERCHANTABILITY AND FITNESS FOR A PARTICULAR PURPOSE ARE EXCLUDED. SOME STATES DO NOT ALLOW LIMITATIONS ON HOW LONG AN IMPLIED WARRANTY LASTS, SO THE ABOVE LIMITATION MAY NOT APPLY TO YOU.

JET SHALL IN NO EVENT BE LIABLE FOR DEATH, INJURIES TO PERSONS OR PROPERTY, OR FOR INCIDENTAL, CONTINGENT, SPECIAL, OR CONSEQUENTIAL DAMAGES ARISING FROM THE USE OF OUR PRODUCTS. SOME STATES DO NOT ALLOW THE EXCLUSION OR LIMITATION OF INCIDENTAL OR CONSEQUENTIAL DAMAGES, SO THE ABOVE LIMITATION OR EXCLUSION MAY NOT APPLY TO YOU.

JET sells through distributors only. The specifications listed in JET printed materials and on official JET website are given as general information and are not binding. JET reserves the right to effect at any time, without prior notice, those alterations to parts, fittings, and accessory equipment which they may deem necessary for any reason whatsoever. JET® branded products are not sold in Canada by JPW Industries, Inc.

Product Listing with Warranty Period

90 Days – Parts; Consumable items
1 Year – Motors; Machine Accessories
2 Year – Metalworking Machinery; Electric Hoists, Electric Hoist Accessories; Woodworking Machinery used for industrial or commercial purposes
5 Year – Woodworking Machinery
Limited Lifetime – JET Parallel clamps; VOLT Series Electric Hoists; Manual Hoists; Manual Hoist Accessories; Shop Tools; Warehouse & Dock products; Hand Tools; Air Tools

NOTE: JET is a division of JPW Industries, Inc. References in this document to JET also apply to JPW Industries, Inc., or any of its successors in interest to the JET brand.