

7" METAL CUTTING BAND SAW



712N



712DR

INSTRUCTION MANUAL

712N/DR -080218-R7



WARNING !

Some dust created by power sanding, sawing, grinding, drilling, and other construction activities contains chemicals known to the State of California to cause cancer, birth defects or other reproductive harm. Some examples of these chemical are:

- Lead from lead-based paints.
- Crystalline silica from bricks, cement and other masonry products.
- Arsenic and chromium from chemically-treated lumber.

Your risk from these exposures varies, depending on how often you do this type of work. To reduce your exposure to these chemicals: Work in a well ventilated area, and work with approved safety equipment, such as those dust masks that are specially designed to filter out microscopic particles.

Table Of Contents

Page No

1 Warning	2
2 Safety rules for all tools	2
3 Specification	4
4 Transportation of machine	5
5 Installation	5
6 Minimum Room Space For Machine Operation	6
7 Make proper tooth selection	6
8 BI-Metal speeds and feeds	7
9 Assembly	8
10 Operation	9
11 Blade guide bearing adjustment	14
12 Blade track adjustment	15
13 Maintenance	16
14 Lubrication	17
15 Trouble Shooting	17
16 Wiring Diagram.....	19
17 Circuit Diagram	21
18 Parts Lists & Drawing	23

CAUTION

Install saw blade and blade guard before use. Set proper blade tension to prevent any danger caused by damaged saw blade or work piece.

1. WARNING: FAILURE TO FOLLOW THESE RULES MAY RESULT IN SERIOUS PERSONAL INJURY

As with all machinery there are certain hazards involved with operation and use of the machine. Using the machine with respect and caution will considerably lessen the possibility of personal injury. However, if normal safety precautions are overlooked or ignored, personal injury to the operator may result.

This machine was designed for certain applications only. We strongly recommends that this machine NOT be modified and/or used for any application other than for which it was designed. If you have any questions relative to its application DO NOT use the machine until you contact with us and we have advised you.

Always install the plastic belt cover before operating the machine.

Your machine might not come with a power socket or plug. Before using this machine, please Do ask your local dealer to install the socket or plug on the power cable end

2. SAFETY RULES FOR ALL TOOLS

A. USER:

(1). **WEAR PROPER APPAREL.** No loose clothing, gloves, rings, bracelets, or other jewelry to get caught in moving parts.

Non-slip foot wear is recommended. Wear protective hair covering to contain long hair.

(2). **ALWAYS WEAR EYE PROTECTION.** Refer to ANSLZ87.1 standard for appropriate recommendations.

Also use face or dust mask if cutting operation is dusty.

(3). **DON'T OVERREACH.** Keep proper footing and balance at all times.

(4). **NEVER STAND ON TOOL.** Serious injury could occur if the tool is tipped or if the cutting tool is accidentally contacted.

(5). **NEVER LEAVE TOOL RUNNING UNATTENDED. TURN POWER OFF.**

Don't leave tool until it comes to a complete stop.

(6). **DRUGS, ALCOHOL, MEDICATION.**

Do not operate tool while under the influence of drug, alcohol or any medication.

(7). **MAKE SURE TOOL IS DISCONNECTED FROM POWER**

SUPPLY. While motor is being mounted, connected or reconnected.

(8). **ALWAYS** keep hands and fingers away from the blade.

(9). **STOP** the machine before removing chips.

(10). **SHUT- OFF** power and clean the BAND SAW and work area before leaving the machine.

B. USE OF MACHINE:

(1). **REMOVE ADJUSTING KEYS AND WRENCHES.** Form habit of checking to see that keys and adjusting wrenches are removed from tool before turning it "on".

(2). **DON'T FORCE TOOL.** It will do the job better and be safer at the rate for which it was designed.

(3). **USE RIGHT TOOL.** Don't force tool or attachment to do a job for which it was not designed.

(4). **SECURE WORK.** Use clamps or a vise to hold work when practical. It's safer than using your hand frees both hands to operate tool.

(5). **MAINTAIN TOOLS IN TOP CONDITION.** Keep tools sharp and clean

for best and safest performance. Follow instructions for lubricating and changing accessories.

(6). **USE RECOMMENDED ACCESSORIES.** Consult the owner's manual for recommended accessories. The use of improper accessories may cause hazards.

(7). **AVOID ACCIDENTAL STARTING.** Make sure switch is in "OFF" position before plugging in power cord.

(8). **DIRECTION OF FEED.** Feed work into a blade or cutter against the direction of rotation of the blade or cutter only.

(9). **ADJUST AND POSITION** the blade guide arm before starting the cut.

(10). **KEEP BLADE GUIDE ARM TIGHT,** A loose blade guide arm will affect sawing accuracy .

(11). **MAKE SURE** blade speed is set correctly for material being cut.

(12). **CHECK** for proper blade size and type.

(13). **STOP** the machine before putting material in the vise.

(14). **ALWAYS** have stock firmly clamped in vise before starting cut.

(15). **GROUND ALL TOOLS.** If tool is equipped with three-prong plug, it should be plugged into a three-hole electrical receptacle. If an adapter is used to accommodate a two-prong receptacle, the adapter lug must be attached to a known ground. Never removed the third prong.

C. ADJUSTMENT :

MAKE all adjustments with the power off. In order to obtain the machine. Precision and correct ways of adjustment while assembling, the user should read the detailed instruction in this manual.

D. WORKING ENVIRONMENT:

(1). **KEEP WORK AREA CLEAN.** Cluttered areas and benches invite accidents.

(2). **DON'T USE IN DANGEROUS ENVIRONMENT.** Don't use power tools in damp or wet locations, or expose them to rain. Keep work area well-lighted.

(3). **KEEP CHILDREN AND VISITORS AWAY.** All children and visitors should be kept a safe distance from work area.

(4). **DON'T** install & use this machine in explosive, dangerous environment.

E. MAINTENANCE:

(1). **DISCONNECT** machine from power source when making repairs.

(2). **CHECK DAMAGED PARTS.** Before further use of the tool, a guard or other part that is damaged should be carefully checked to ensure that it will operate properly and perform its intended function check for alignment of moving parts, binding of moving parts, breakage of parts, mounting, and any other conditions that may affect its operation. A guard or other part that is damaged should be properly repaired or replaced.

(3). **DISCONNECT TOOLS** before servicing and when changing accessories such as blades, bits, cutters, etc.

(4). **MAKE SURE** that blade tension and blade tacking are properly adjusted.

(5). **RE-CHECK** blade tension after initial cut with a new blade.

(6). **TO PROLONG BLADE LIFE ALWAYS** release blade tension at the end of each work day.

(7). **CHECK COOLANT DAILY** Low coolant level can cause foaming and high blade temperatures. Dirty or weak coolant can clog pump, cause crooked. Cast, low cutting rate and permanent blade failure. Dirty coolant can cause the growth of

bacteria with ensuing skin irritation.

(8). WHEN CUTTING MAGNESIUM

NEVER use soluble oils or emulsions(oil-water mix) as water will greatly intensify any accidental magnesium chip fire. See your industrial coolant supplier for specific coolant recommendations when cutting magnesium.

(9). TO PRNMT corrosion of machined surfaces when a soluble on is used as coolant, pay particular attention to wiping dry the surfaces where fluid accumulates and does not evaporate quickly, such as between the machine bed and vise.

F. SPECTIFIED USAGE:

This machine is used only for general metals cutting within the range of cutting capacity.

CAUTION :

READ ALL INSTRUCTION CAREFULLY BEFORE USING THIS NACHINE. SAVE THIS MANUAL.

G. NOISE:

A weighted sound pressure level : 80 dB.

H. SAFETY DEVICE:

(1). Interlock switch on pulley cover.

As soon as the pulley cover is open, Machine will stop with the function of this switch. Do not remove this switch from machine for any reason, and check it's function frequently.

(2). Interlock switch on cutting area as soon as the cover of cutting area in open, machine will stop at once witch the function of this switch, do not remove this switch from machine for any reason, and check it's function frequently.

3. SPECIFICATION:

MOTOR		0.55KW (3/4HP) / 1HP	
Blade Size		19.05 x 0.8 x 2362 mm (Carbon Blade)	
Saw Blade Speed	60Hz (FPM)	90,135,195,255	98,164,246,328
	50Hz (FPM)	70,110,160,210	81,135,203,270
MODEL NO. CUTTING CAPACITY		712N	712DR
90°	○(mm)	178(7")	178(7")
	□(mm)	178x305(7"x12")	178x210(7"x8 1/4")
45°	○(mm)	127(5")	127(5")
	□(mm)	125x120 (4 3/4" x 4 5/8")	85x140(3 1/3"x5 1/2")
-45°	○(mm)		127(5")
	□(mm)		85x140(3 1/3"x5 1/2")
Dimension LxWxH (mm)		1235x430x955	1240x620x1135
N.W / G.W (kgs)		135 / 170	150/175

Packing Measurement (mm) LxWxH	1270x457x990	1320x749x1150
-----------------------------------	--------------	---------------

4. TRANSPORTATION OF MACHINE:

Unpacking

1. Transportation to desired location before unpacking, please use lifting jack.(Fig. B)
2. Transportation after unpacking, please use heavy duty fiber belt to lift up the machine.

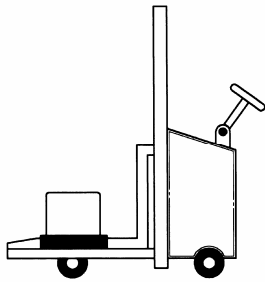

Fig. B

ALLWAYS KEEP PROPER FOOTING & BALANCE WHILE MOVING THIS MACHINE.

5, Installation:

As this machine weights 125 kg. It is recommended that the machine shall be transported, with help of lifting jack.

Transportation Recommendation:

- (1). Tighten all locks before operation.
- (2). **ALWAYS** Keep proper footing & balance while moving this 125kgs machine, and only use heavy duty fiber belt to lift the machine as Fig. A
- (3). **TURN OFF** the power before wiring, & be sure machine in proper grounding, Overload & circuit breaker is recommended for safety wiring.
- (4). **CHECK** carefully if the saw blade is running in counter-clockwise direction if not , reverse the wiring per circuit diagram then repeat the running test.
- (5). **KEEP** machine always out from sun, dust, wet, raining area.

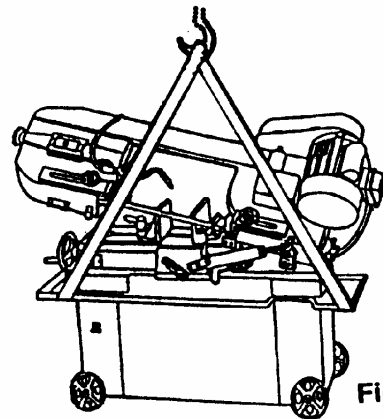
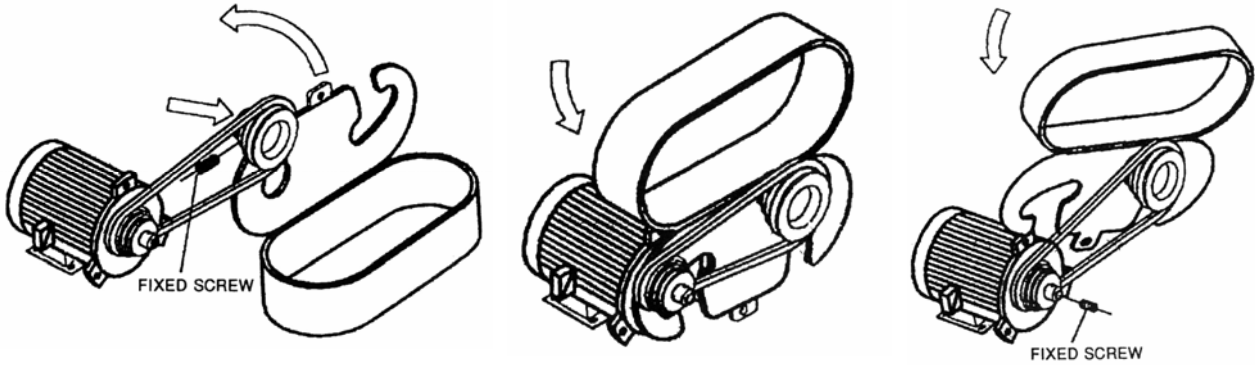

Fig. A

Installation steps for plastic belt cover:

- A), Open plastic moulded belt cover. Inlay the left indentation to the bottom of the pulley. If the gap is too small. Loose the fixing screws of pulley. Then, move the pulley out slightly, it will be very easy to set in.
- B). Turn the belt cover with the direction of counterclockwise, which enable the indentation set into the pulley. If the gap is too small. Loose the fixing screws of pulley, and move the pulley out slightly, then, it will be easy to set in.

C). Inlay the left indentation completely to the pulley. Adjust the pulley at the same level surface, then, fix all related screws.



6. MINIMUM ROOM SPACE FOR MACHINE OPERATION

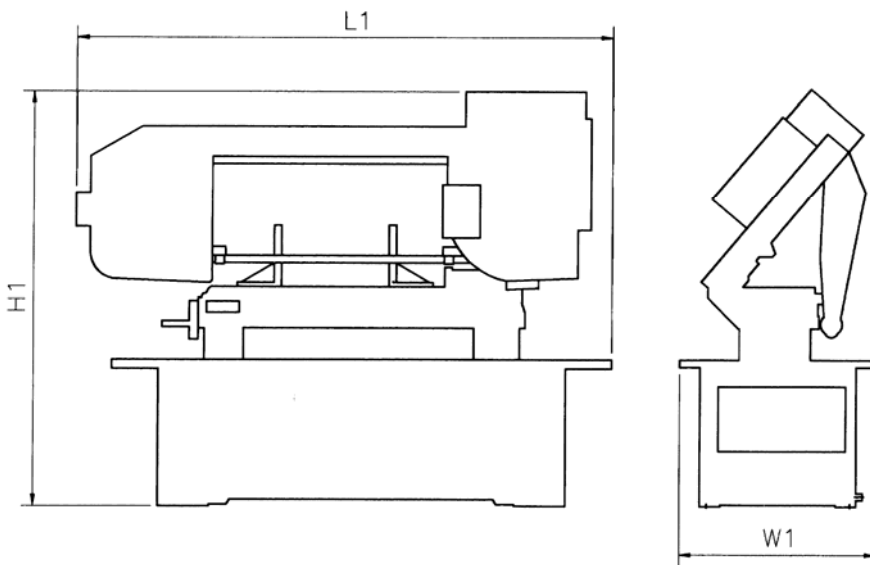

Model No.	712N	712DR
Dimension L1xW1xH1(mm)	1235x430x955	1240x620x1135

7. MAKE PROPER TOOTH SELECTION

For maximum cutting efficiency and lowest cost per cut, it is important to select the blade with the right number of teeth per inch (TPI) for the material being cut. The material size and shape dictate tooth selection.

You need to consider:

- 1.The width of the cut. That is, the distance in the cut that each tooth must travel from the point it enters the workpiece until it leaves the workpiece, and
- 2.The shape of the workpiece.

● **Squares, Rectangles, Flats (Symbol : ■)**

Locate the width of cut on the chart.

	101,102,110,122,172	234	71
	1751,182,220,510	234	71
	625,706,715,934	234	71
	630	229	70
	811	214	65
Carbon Steel	1117	339	103
	1137	289	88
	1141,1144	279	85
	1141 HI STRESS	279	85
	1030	329	100
	1008,1015,1020,1025	319	97
	1035	309	94
	1018,1021,1022	299	91
	1026,1513	299	91
	A36(SHAPE S),1040	269	82
	1042,1541	249	76
1044,1045	219	67	
1060	199	61	
1095	184	56	
Ni-Cr-Mo Alloy Steel	8615,8620,8622	239	73
	8640,	199	61
	E9310	174	53
Tool Steel	A-6	199	61
	A-2	179	55
	A-10	159	49
	D-2	90	27

	H-11,H-12,H-13	189	58
Stainless Steel	420	189	58
	430	149	46
	410,502	140	43
	414	115	35
	431	95	29
	440C	80	24
	304,324	120	36
	304L	115	35
	347	110	33
316,316L	100	30	
416	189	58	

TELLTALE CHIPS

Chips are the best indicator of correct feed force. Monitor chip information and adjust feed accordingly.

Thin or powdered chips – increase feed rate or reduce band speed.



Burned heavy

chips – reduce feed rate and/or band speed.



Curly silvery and warm chips – optimum feed rate and band speed.



9. ASSEMBLY

A 3/4 HP, motor, split phase or capacitor-start it recommended for best economical performance.

Counterclockwise rotation is required. Note that rotation can be reversed by allowing directions given on terminal or nameplate.

- (1). Assemble the motor Mounting plate to the head using the long bolt Note that the flat side of the plate faces up.
- (2). Assemble the guard plate to the head using the screw and Lock Washer and the Carriage Bolt Washer and Wing Nut are used to secure the motor mounting plate to the Guard plate through the slotted hole in the Guard plate. These components also serve to position and lock the motor in place for proper speed/ belt adjustment.
- (3). Place the spacer over the long Bolt and secure it with the nut .
- (4). Secure the Motor to the Motor Mounting plate with the four bolts and nuts. Note, that the motor shaft is placed through the large opening in the Guard plate and must be parallel with the drive Shaft.
- (5). Assemble the Motor Pulley, the smaller of the two provided, to the motor shaft Note, the larger diameter must be closest to the motor.
Do not tighten the set screw.
- (6). Assemble the Driven Pulley, the larger of the two provided, to the protruding drive Shaft Note the small diameter must be closest to the bearing.
Do not tighten the set screw.
- (7). Place the belt into one of the pulley grooves and the other end into the respective grooves of the second pulley.
- (8) Line up the belt and both pulleys such that the belt is running parallel in the pulley grooves.
- (9). Tighten the set screws of both pulleys in this position.
- (10). Place the belt into proper pulley combination for proper blade speed. See material cutting Chart .
- (11). Adjust the position of the Motor to obtain approximately 1/2" depression in the belt when applying pressure with your

thumb.

(12). Tighten the head screw Holding the Motor Mounting plate to the Guard plate.

(13). Connect the Electrical Harness to the motor terminal box. The motor should be protected with a time delay fuse or circuit breaker with a rated amperage slightly greater than the full load amperage of the motor.

10. OPERATION

A. WORK SET UP:

- (1). Raise the saw head to vertical position.
- (2). Open vise to accept the Piece to be cut by rotating the wheel at the end the base.
- (3). Place workpiece on saw bed. If the piece is long, support the end.
- (4). Clamp workpiece securely in vise.

B. WORK STOP ADJUSTMENT:

- (1). Loosen the thumb screw holding the work stop casting to the shaft.
- (2). Adjust the work stop casting to the desired length position.
- (3). Rotate the work stop to as close to the bottom of the cut as possible.
- (4). Tighten thumbscrew.
- (5). **DO NOT ALLOW** the blade to rest on the work while the motor is shut off.

C. BLADE SPEEDS:

When using your Band saw always change the blade speed to best suit the material being cut the material Cutting Chart gives suggested settings for several materials.

Material	Speed F.P.M				Belt Groove Used	
	60Hz		50Hz		Motor Pulley	Saw Pulley
	A	B	A	B		
Tool, Stainless Alloy Steels Bearing Bronze	90	98	70	81	Small	Largest
Medium to High Carbon Steels Hard Brass or Bronze	135	164	110	135	Medium	Large
Low to Medium Carbon Steel Soft Brass	195	246	160	203	Large	Medium
Aluminum Plastic	255	328	210	270	Largest	Small

- ✧ A: For 712N with carbon blade
- ✧ B: For 712DR, 712N with Bi-Metal blade.

D. BLADE DIRECTION OF TRAVEL:

Be sure the blade is assembled to the pulleys such that the vertical edge engages the work piece first.

BLADE MOVEMENT

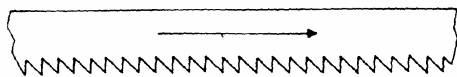

Blade Direction

E. STARTING SAW:

E-1. Switch button function description

- A** ↑ Stop button
- B** ↑ Start button

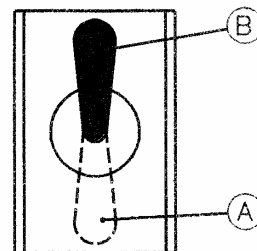

Toggle Switch

**E-2. Switch button function description
(FOR CE ONLY)**

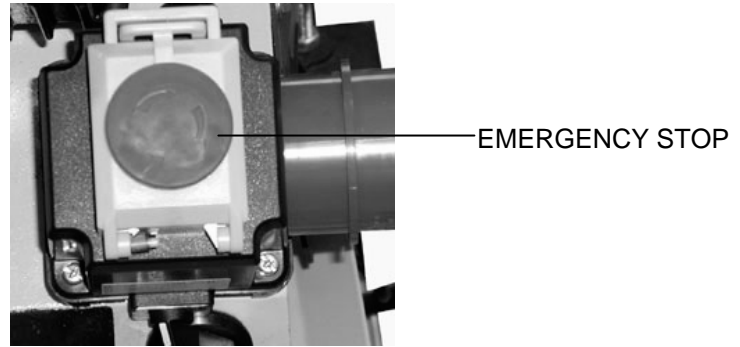
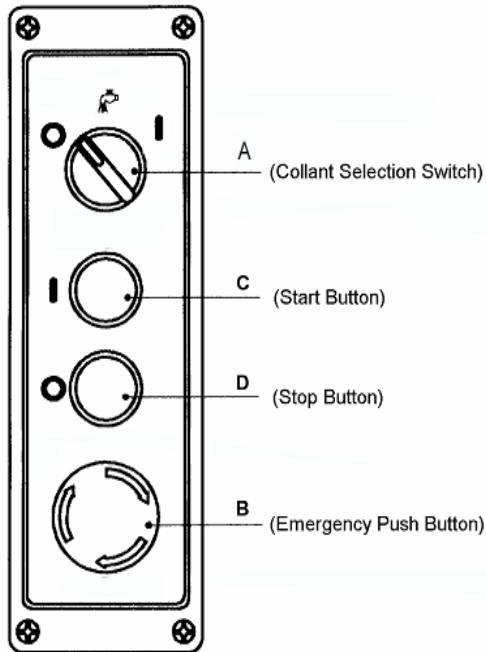

EMERGENCY STOP button

CAUTION: NEVER OPERATE SAW WITHOUT BLADE GUARDS IN PLACE. Be sure the blade is not in contact with the work when the motor is started. Start the motor, allow the saw to come to full speed, then begin the cut by letting the head down slowly onto the work. **DO NOT DROP OR FORCE.** Let the weight of the saw head provide the cutting force. The saw automatically shuts off at the end of the cut.

E-3. Electromagnetic Switch

The self-latching, lockable EMERGENCY STOP button is equipped with an under voltage circuit breaker.

When the switch is in closed position, it may be secured with a padlock to prevent the machine from being turned on accidentally or by unauthorized personnel.

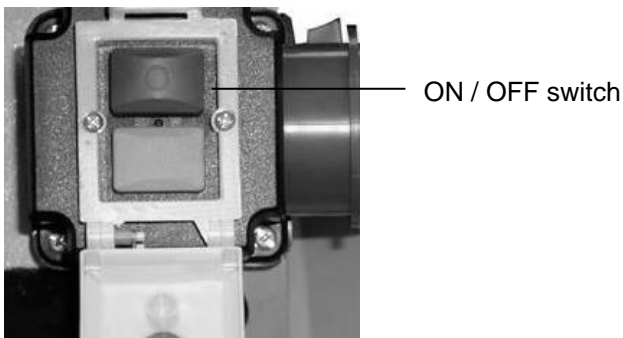

ON / OFF switch

Open the cover of the switch in order to switch on the metal belt saw. Close the cover after switching on to guarantee correct operation of the EMERGENCY STOP function.

F. BLADE SELECTION:

A 8-tooth per inch, general-use blade is furnished with this metal Cutting Band Saw. Additional blades in 4, 6, 8, and 10 tooth sizes are available. The choice of blade pitch is governed by the thickness of the work to be cut: the thinner the workpiece, the more teeth advised. A minimum of three (3) teeth should be against the workpiece at all times for proper cutting. If the teeth of the Blade are so far apart that they straddle the work, severe damage to the workpiece and to the Machine can result.

G. CHANGING BLADE:

Raise saw head to vertical position and open the blade guards. Loosen tension screw knob sufficiently to allow the saw blade to slip off the wheels. Install the new blade with teeth slanting toward the motor as follows:

- (1). Place the blade in between each of the guide bearings.
- (2). Slip the blade around the motor pulley (bottom) with the left hand and hold in position.
- (3). Hold the blade taut against the motor pulley by pulling the blade upward with the right hand which is placed at the top of the Made.
- (4). Remove left hand from bottom pulley and place is at the top aide of the Made to continue the application on the upward pull on the blade.
- (5). Remove right hand from blade and adjust the position of the top pulley to permit left hand to slip the blade around the pulley using the thumb, index and little finger as guides.
- (6). Adjust the blade tension knob clockwise until it is just right enough so no blade slippage occurs. Do not tighten excessively.
- (7). Replace the blade guards.
- (8). Place 2-3 drops of oil on the blade.

H. USAGE OF THE QUICK VISE: (A)

The workpiece is placed between the vise jaws with the amount to be cut-off extending out past the blade. Your machine is equipped with a "quick action" vise jaw which allows you to instantly position the moveable vise jaw (B). Simply turn handwheel (A) counterclockwise 1/2 turn and move the vise jaw (B) to the desired position. Then tighten the vise jaw

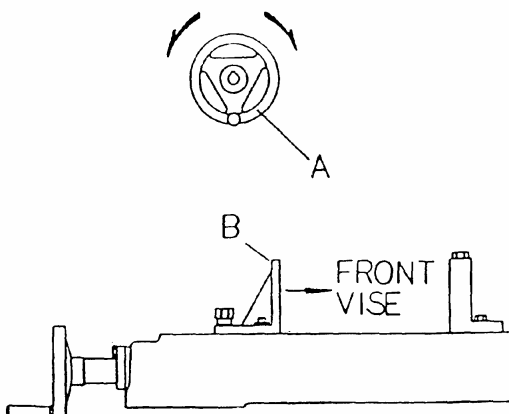

(B) against the work-piece by turning hand-wheel clockwise.

H. USAGE OF THE QUICK VISE: (B)

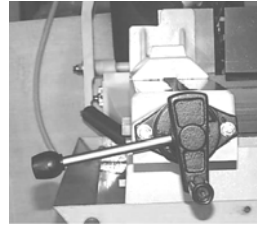

(1)



(2)

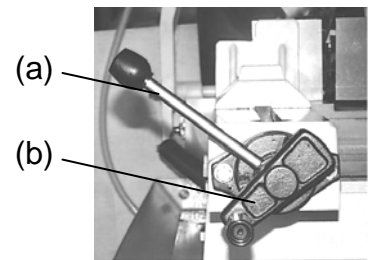

(3)

- (1) The position of the vise when tightened.
- (2) The position of the vise when loosened. (Completely opened).
- (3) The position of the vise when loosened. (Half opened).

TRU-LOCK VISE SYSTEM INSTRUCTIONS

To operate, proceed as follows:

- 1) Rise the arm 2" above the workpiece, close the cylinder valve to maintain the arm 2" above the workpiece.
- 2) Put your workpiece on the table. Move the vise handle (a) upwards to an angle of 45 degree (a-Half opened) to loosen the vise. Move the vise jaw bracket against the workpiece by turning the rectangular handle (b) . Push down on the vise handle (a) to lock the workpiece in position.
- 3) To loosen the workpiece from the vise, hold the workpiece and lift the vise

handle (a) to a 90 degree position (completely opened). Remove workpiece.

CONTINUED CUTTING

When you need to cut a workpiece many times, just raise the vise handle (a) to loosen and adjust workpiece position. Then push down on the same handle to tighten.

You can also push the vise handle (a) down first, then tightening the vise by turning the rectangular handle (b) clockwise. After finishing the cut, you can loosen the workpiece by turning rectangular handle only.

This Tru-Lock Vise System has a 3mm tightening travel when the rectangular handle is completely opened. There is only a 1mm tightening travel necessary for normal metal materials. The operator can tighten the workpiece by pushing down the vise handle (a) with a certain amount of pressure depending on hardness of workpiece.

I. QUICK VISE ADJUSTMENT FOR ANGLE CUT:

- (1). Loosen the A. B. C. D. Screw.
- (2). Adjust rear vise to the threaded hole position. (E)
- (3). Set the scale to the desired angle.
- (4). Adjust the front vise (F) to parallel the rear vise (E)
- (5). Tighten the A. B. C. D. Screw.

I-1 The position for 0° cutting. (The original position)(See fig1.)

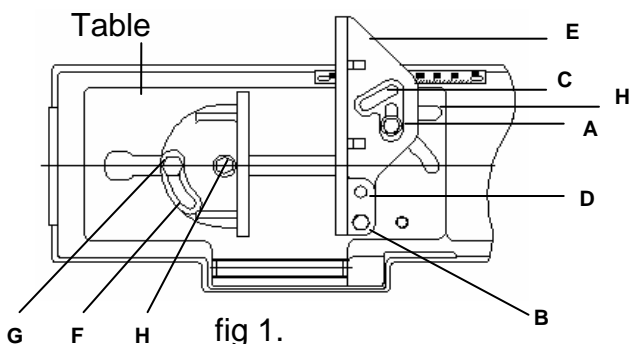

I-2 The position for 90° cutting. (See fig2.)

- Step: 1.Remove the screw from A to C.
- 2.Remove the screw from B to D.
- 3.Turn E (Rear vise) to the right.
- 4.Turn F (Front vise) to the right.

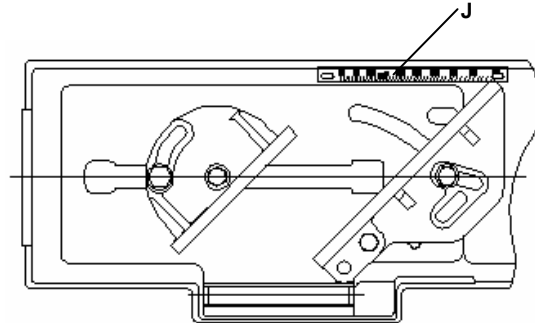

fig 2.

I-3 The position for cutting 12" workpiece. (See fig3.)

- Step:1.Disconnect the metal belt saw from the power supply.
- 2.Unscrew the bolts on the rear clamping jaw.
- 3.Set the clamping jaw at a greater distance in the holes provided.
- 4.Screw the clamping jaw back in.

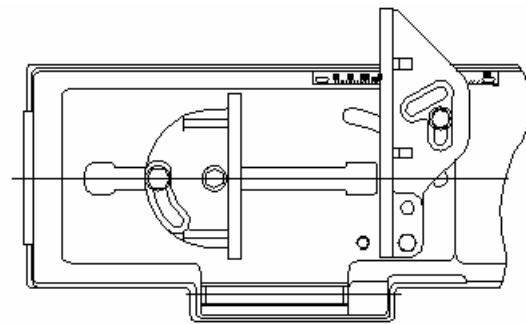

fig 3.

j. FRONT AND REAR CUTTING

OPERATION: FOR 712DR ONLY

1), For front cutting: ←
Push the vise base backward (far from you) to the end, fix the 3 vise base fix screws (A).

Choose the swivel arm angle you need start cutting.

2), For rear cutting: →

Push the vice base backward (close to you) to the end, fix the 3 vice base fix screws (A).

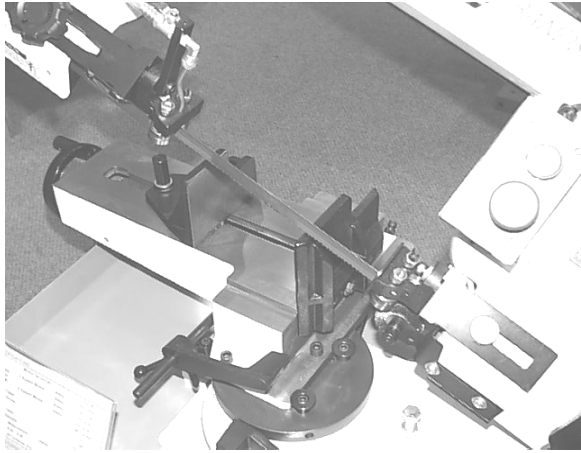

Choose the swivel arm angle you need start cutting.

k. HOW TO OPERATE THE SWIVEL CUTTING

- 1), Loosen the leaf screw (A)
- 2), Move the swivel bow by the hand, watch the angle scale to the desired angle.
- 3), Lock the leaf screw (A)
- 4), Adjust cylinder volume, and start cutting.

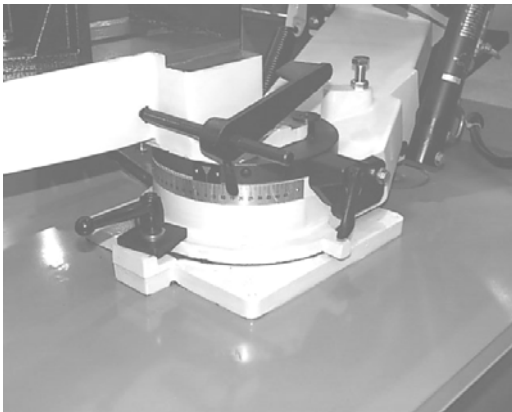

11. BLADE GUIDE BEARING ADJUSTMENT

ATTENTION: This is the most important adjustment on your saw. It is impossible to get satisfactory work from your saw if the blade guides are not properly adjusted. The blade guide bearings on your metal Cutting Band Saw are adjusted and power

tested with several test cuts before leaving the factory to insure proper setting. The need for adjustment should rarely occur when the saw is used properly. If the guides do get out of adjustment though, it is extremely important to readjust immediately. If improper adjustment is maintained, the blade will not cut straight, and if the situation is not corrected it will cause serious blade damage. Because guide adjustment is a critical factor in the performance of your saw, it is always best to try a new blade to see if this will correct poor cutting before beginning to adjust. If a blade becomes dull on one side sooner than the other, for example, it will begin cutting crooked. A blade change will correct this problem the guide adjustment will not. If a new blade does not correct the problem, check the blade guides for proper spacing.

NOTE: There should be from 000 (just touching) 001 clearance between the blade and guide bearings to obtain this clearance adjust as follows:

1. The inner guide bearing is fixed and cannot be adjusted.
2. The outer guide bearing is mounted to an eccentric bushing and can be adjusted.
3. Loosen the nut while holding the bolt with an Alien wrench.
4. Position the eccentric by turning the bolt to the desired position of clearance.
5. Tighten the nut.
6. Adjust the second blade guide bearing in the same manner.

REMARK:

1. Adjust the tension of blade until the back of the blade(A) against the blade wheel (front) lightly.
2. Be sure the nut (E) is tightened.
3. Turn the eccentric shaft (B) counterclockwise, when the bearing (D)

touches the saw blade properly, tighten the nut(E).

4. To adjust, loosen set screw (F) and move the blade adjustable up or down until it lightly touches the back of the blade (A).

5. Repeat 1, 2, 3, and 4 steps to adjust the other side's blade guide bearings (G).

6. Correct the base and blade to be a vertical position with a scale. If necessary, loosen set screw (F).

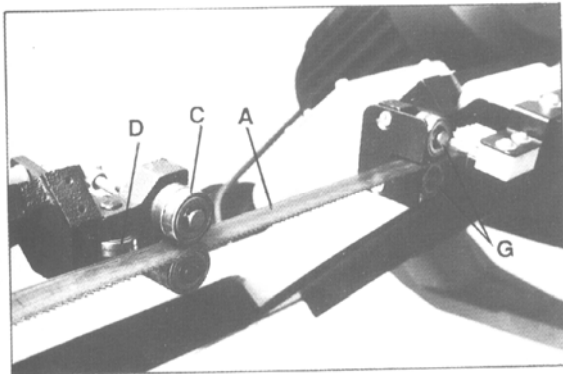

7. Set down the blade frame, correct the jaw vise (H) and blade to be a vertical position with a scale then tighten the set screws (I).

8. Loosen set screw (K), move front jaw vise (J) to against rear jaw vise(H) tightly. Finish correcting by tightening set screw (K).

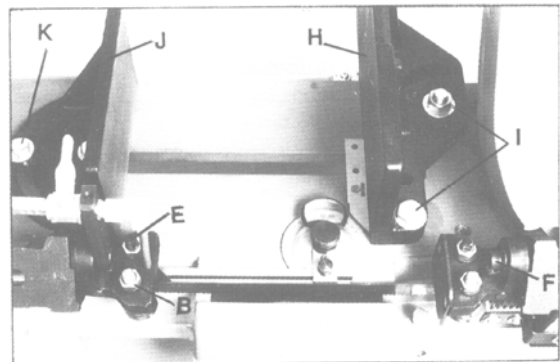

For 712DR, when straight cutting 12" width is required, changing Rear Vise Jaw Bracket is a MUST, by following steps.

1. Take off fix screw E, and withdraw the Rear Vise Jaw Bracket (A).

2. Link the Extension Table © to the end of the Vise Base. Fix it with Screw (D).

3. Put back the Vise Bracket (A), fix the screw (E) onto the extension table. Move backward the Front Vise Jaw Bracket.

※※ Extension table is only good for straight cutting, not for angle cutting.

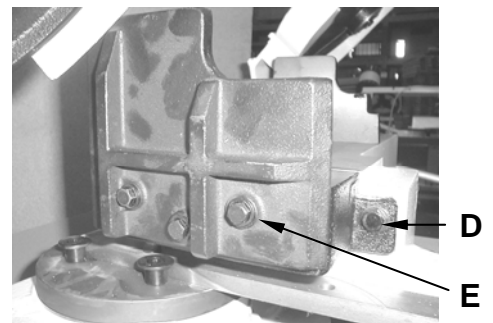

Fig. 1

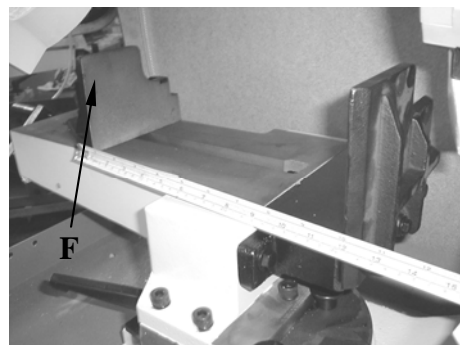

Fig. 3

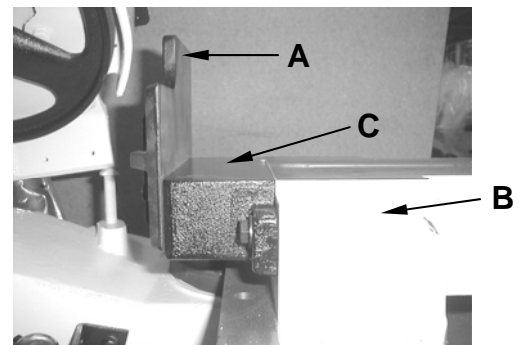

Fig. 2

12. BLADE TRACK ADJUSTMENT

(1). Open the blade guard.

(2). Remove the blade guide assemblies (top and bottom)

(3). Loosen the hex head screw in the tilting mechanism to a point where it is loose but snug.

(4). With the machine running, adjust both the set screw and blade tension knob simultaneously to keep constant tension on the blade. The set screw and blade tension knob are always turned in opposite directions, ie, when one is turned clockwise the other is turned counterclockwise.

The blade is tracking properly when the back side just touches the shoulder of pulley or a slight gap appears near the center line of the pulley. Care should be taken not to over-tighten the saw blade since this will give a false adjustment and limit life of the blade.

(5). Tighten the hex head screw in tilting mechanism. **IMPORTANT:** Sometimes in trying to make this critical adjustment it is possible to cause the basic setting to be misaligned. Should this occur, proceed as follows:

- a. Loosen the set screw and back it out as far as it can go and still remain in the threaded hole.
- b. Turn the hex head screw clockwise until it stops (do not tighten).
- c. Turn the set screw clockwise until it bottoms, then continue for half a turn and check the tracking by turning on the machine.
- d. If further adjustment is required, go back to step 4.

(6). Turn off power to the machine.

(7). Replace the blade guide assemblies--it may be necessary to loosen the blade tension slightly.

(8). Adjust the vertical position of blade guide bearing assemblies so that the back side of the blade just touches the ball bearing.

(9). Make a final run to check tracking. It required, touch up adjustment (See stop 4)

(10). Replace the blade guards.

13. MAINTENANCE

CAUTION: MAKE CERTAIN THAT THE UNIT IS DISCONNECTED FROM THE POWER SOURCE BEFORE ATTEMPTING TO SE RV ICE OR REMOVE ANY COMPONENT.

That's easier to keep machine in good condition or best performance by means of maintaining it at any time than remedy it after it is out of order.

(1) Daily Maintenance (by operator)

(a) Fill the lubricant before starting machine everyday.

(b) If the temperature of spindle caused over-heating or strange noise, stop machine immediately to cheek it for keeping accurate performance.

(c) Keep work area clean; release vise, cutter, work-piece from table; switch off power source; take chip or dust away from machine and follow instructions lubrication or coating rust proof oil before leaving.

(2) Weekly Maintenance

(a) Clean and coat the leading screw with oil.

(b) Check to see if sliding surface and turning parts lack of lubricant. If the lubricant is insufficient, fill it.

(3) Monthly Maintenance

(a) Check if the fixed portion have been loose.

(b) Lubricate bearing, worm, and worm shaft to avoid the wearing.

(4) Yearly Maintenance

(a) Adjust table to horizontal position for maintenance of accuracy.

(b) Check electric cord, plugs, switches at least once a year to avoid loosening or

wearing.

14. LUBRICATION

Lubricate the following components using SAE-30 oil as noted.

- (1). Ball-bearing none.
- (2). Driven pulley bearing 6-8 drops a week.
- (3). Vise lead screw as needed.
- (4). The drive gears run in an oil bath and will not require a lubricant change more often than once a year, unless the lubricant is accidentally contaminated or a

leak occurs because of improper replacement of the gear box cover. During the first few days of operation, the worm gear drive will run hot. Unless the temperature exceeds 200F., there is no cause for alarm.

The following lubricants may be used for the gear box:

- Atlantic Refinery Co. Mogul Cyl. Oil
- Cities Service Gptimus No. 6
- Gulf Refinery Co Medium Gear Oil
- Pure oil Co. Park Clipper

15. TROUBLE SHOOTING

Symptom	Possible Cause(s)	Corrective Action
Excessive Blade Breakage	<ul style="list-style-type: none"> 1. Materials loosen in vise. 2. Incorrect speed or feed 3. Blade teeth spacing too large 4. Material too coarse 5. Incorrect blade tension 6. Teeth in contact with material before saw is started 7. Blade rubs on wheel flange 8. Miss-aligned guide bearings 9. Blade too thick 10 Cracking at weld 	<ul style="list-style-type: none"> 1. Clamp work securely 2. Adjust speed or feed 3. Replace with a small teeth spacing blade 4. Use a blade of slow speed and small teeth spacing 5. Adjust to where blade just does not slip on wheel 6. Place blade in contact with work after motor is started 7. Adjust wheel alignment 8. Adjust guide bearings 9. Use thinner blade 10. Weld again, note the weld skill.
Premature Blade Dulling	<ul style="list-style-type: none"> 1. Teeth too coarse 2. Too much speed 3. Inadequate feed pressure 4. Hard spots or scale on material 5. Work hardening of material. 6. Blade twist 7. Insufficient blade 8. Blade slide 	<ul style="list-style-type: none"> 1. Use finer teeth 2. Decrease speed 3. Decrease spring tension on side of saw 4. Reduce speed, increase feed pressure 5. Increase feed pressure by reducing spring tension 6. Replace with a new blade, and adjust blade tension 7. Tighten blade tension

		adjustable knob 8. Tighten blade tension
Unusual Wear on Side/Back of Blade	1. Blade guides worn. 2. Blade guide bearings not adjusted properly 3. Blade guide bearing bracket is loose	1. Replace. 2. Adjust as per operator's manual 3. Tighten.
Teeth Ripping from Blade.	1. Tooth too coarse for work 2. Too heavy pressure; too slow speed. 3. Vibrating work-piece. 4. Gullet loading	1. Use finer tooth blade. 2. Decrease pressure, increase speed 3. Clamp work piece securely 4. Use coarser tooth blade or brush to remove chips.
Motor running too hot	1. Blade tension too high. 2. Drive belt tension too high. 3. Blade is too coarse for work 4. Blade is too fine for work 5. Gears aligned improperly 6. Gears need lubrication 7. Cut is binding blade	1. Reduce tension on blade. 2. Reduce tension on drive belt. 3. Use finer blade. 4. Use coarse blade. 5. Adjust gears so that worm is in center of gear. 6. Check oil path. 7. Decrease reed anti speed
Bad Cuts (Crooked)	1. Feed pressure too great. 2. Guide bearings not adjusted properly. 3. Inadequate blade tension. 4. Dull blade. 5. Speed incorrect. 6. Blade guides spaced out too much. 7. Blade guide assembly loose 8. Blade truck too far away from wheel flanges.	1. Reduce pressure by increasing spring tension on side of saw 2. Adjust guide bearing, the clearance cannot be greater than 0.001. 3. Increase blade tension by adjusting blade tension 4. Replace blade 5. Adjust speed 6. Adjust guides space. 7. Tighten 8. Re-track blade according to operating instructions.
Bad Cuts (Rough)	1. Too much speed or feed. 2. Blade is too coarse. 3. Blade tension loose.	1. Decrease speed or feed. 2. Replace with finer blade. 3. Adjust blade tension.
Blade is twisting	1. Cut is binding blade. 2. Too much blade tension.	1. Decrease reed pressure. 2. Decrease blade tension.

16.WIRING DIAGRAM

**WIRING DIAGRAM
TOGGLE SWITCH SINGLE PHASE**

712N

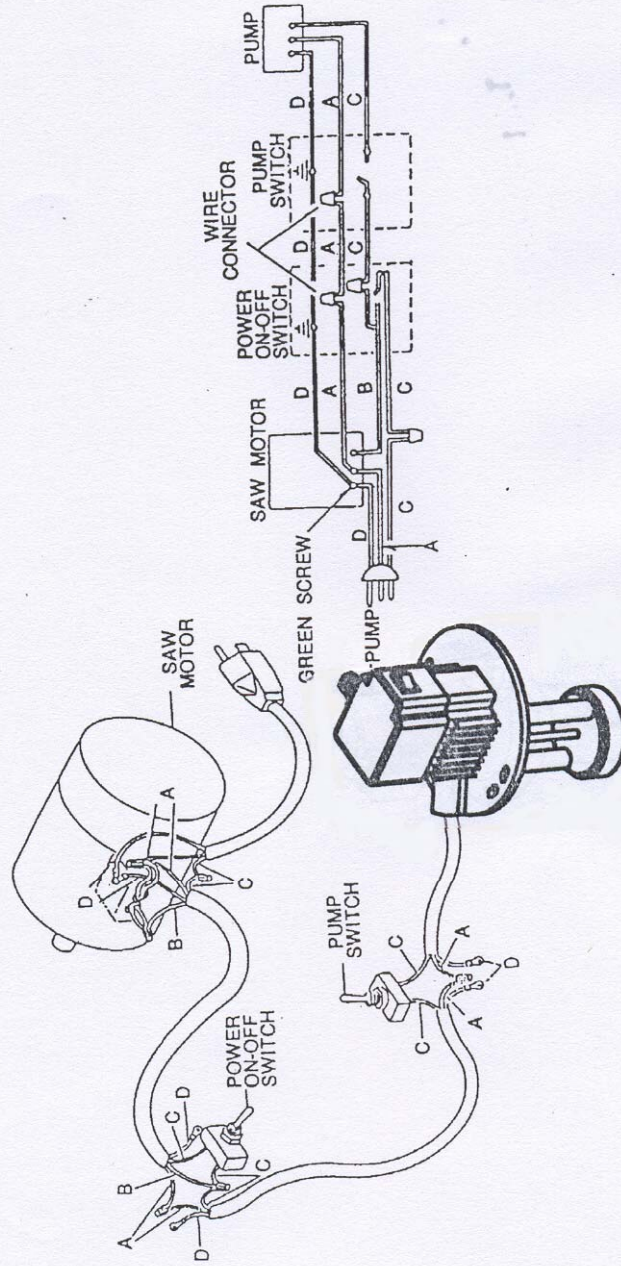

COLOR	REF NO.	A	B	C	D
HZ		BLUE	BLACK	BROWN	YELLOW GREEN
	50	WHITE	RED	BLACK	GREEN
	60				

G0561

Electrical Schematic-110/115V

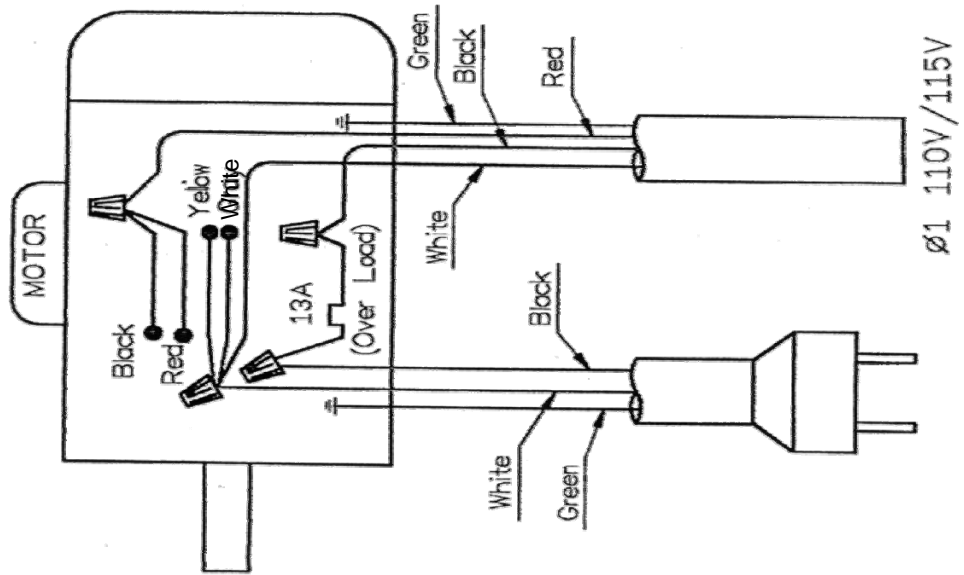

Electrical Schematic-220/230V

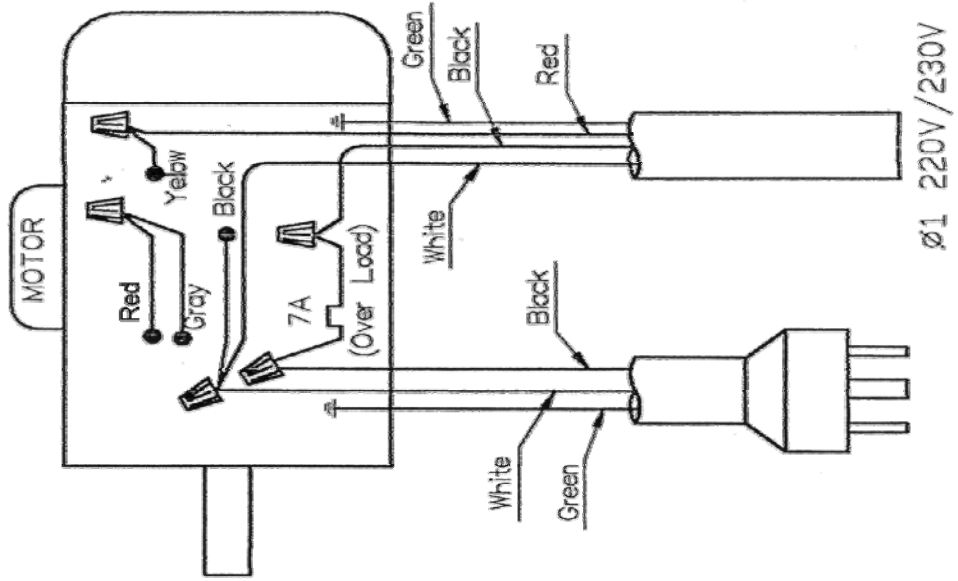

17.CIRCUIT DIAGRAM

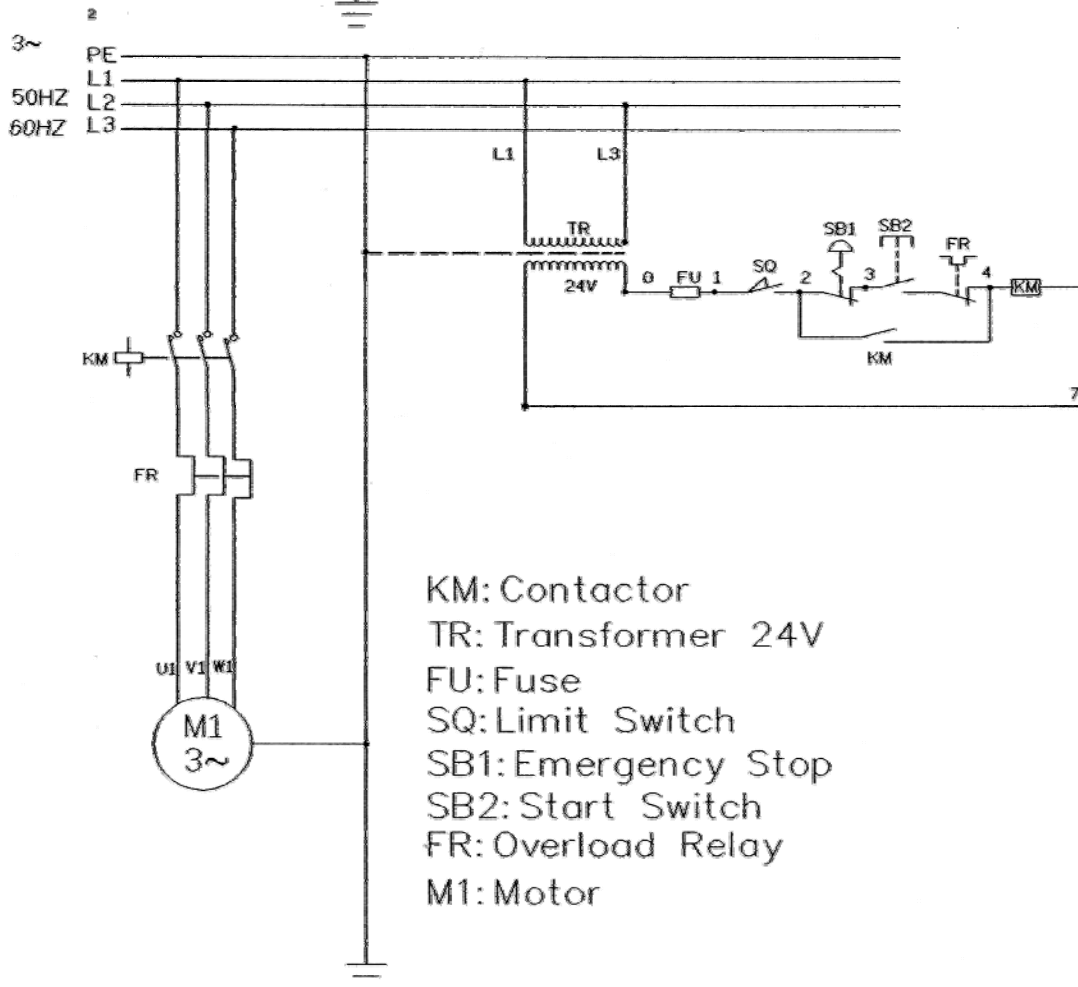
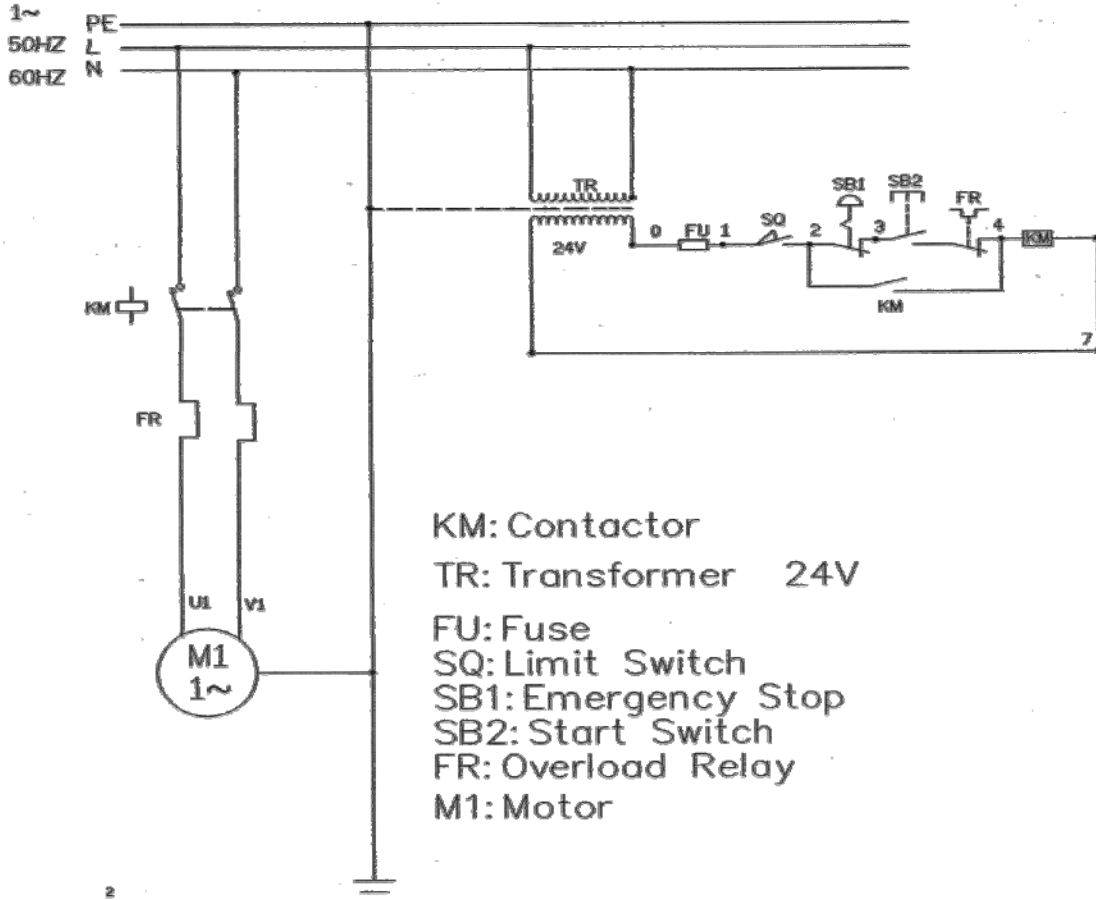

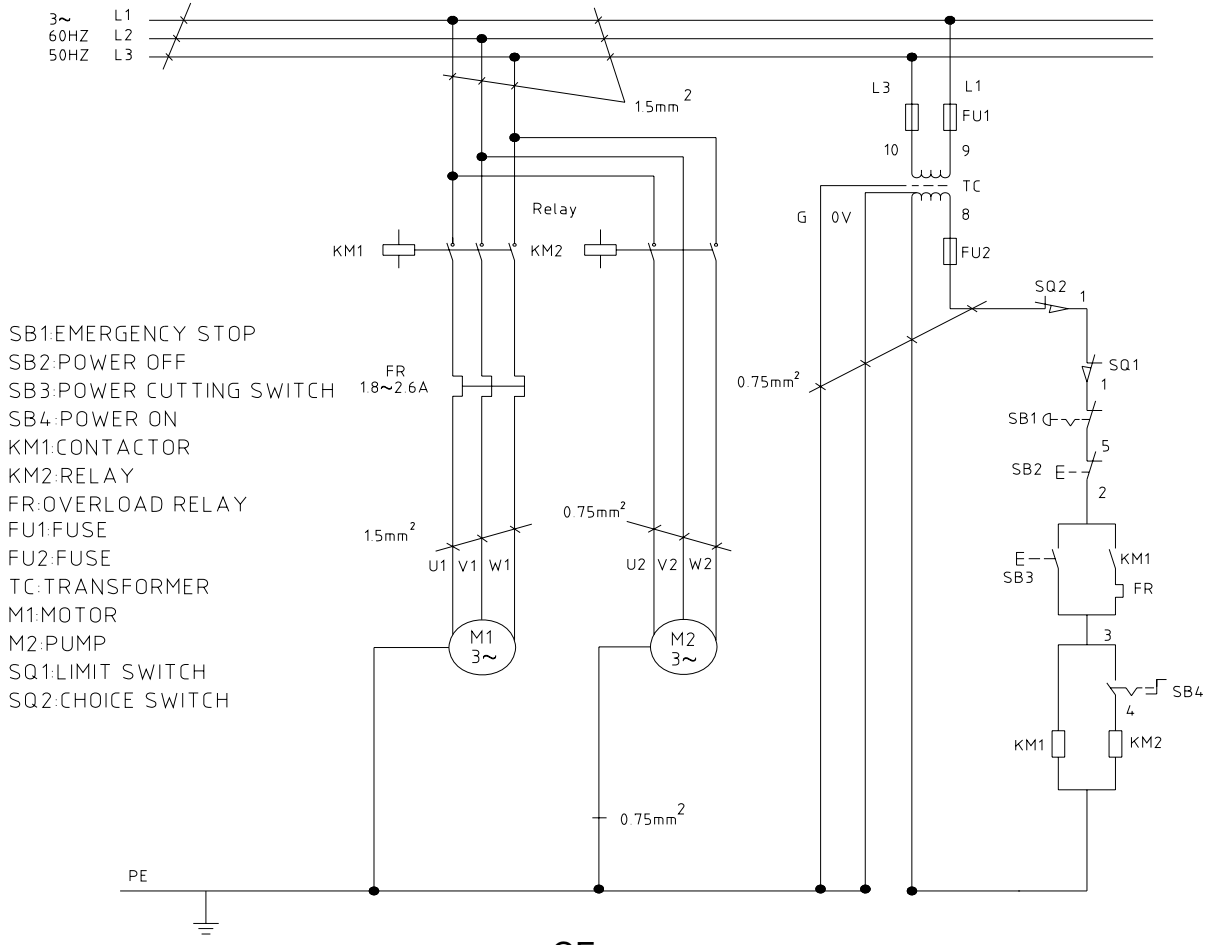

CE

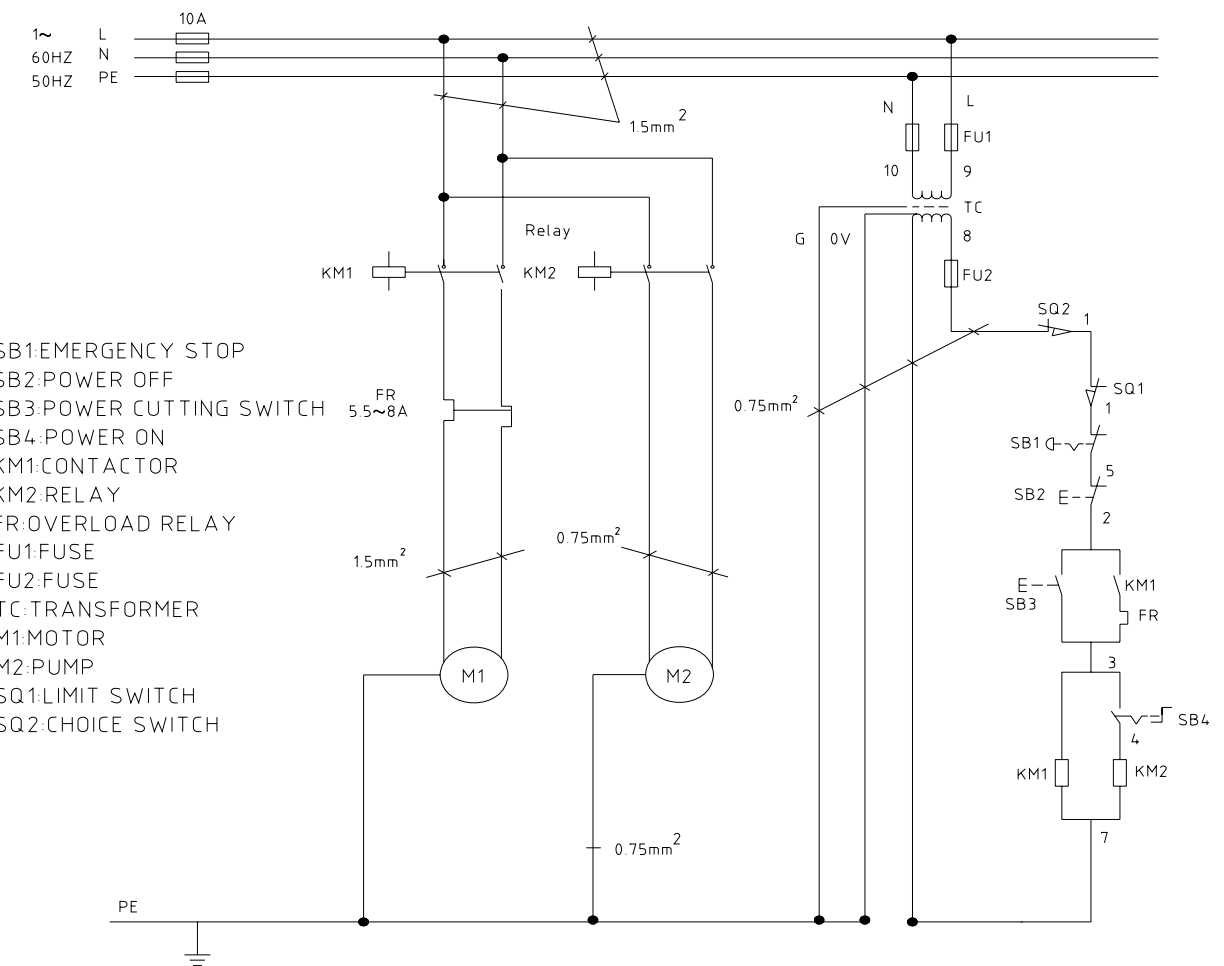

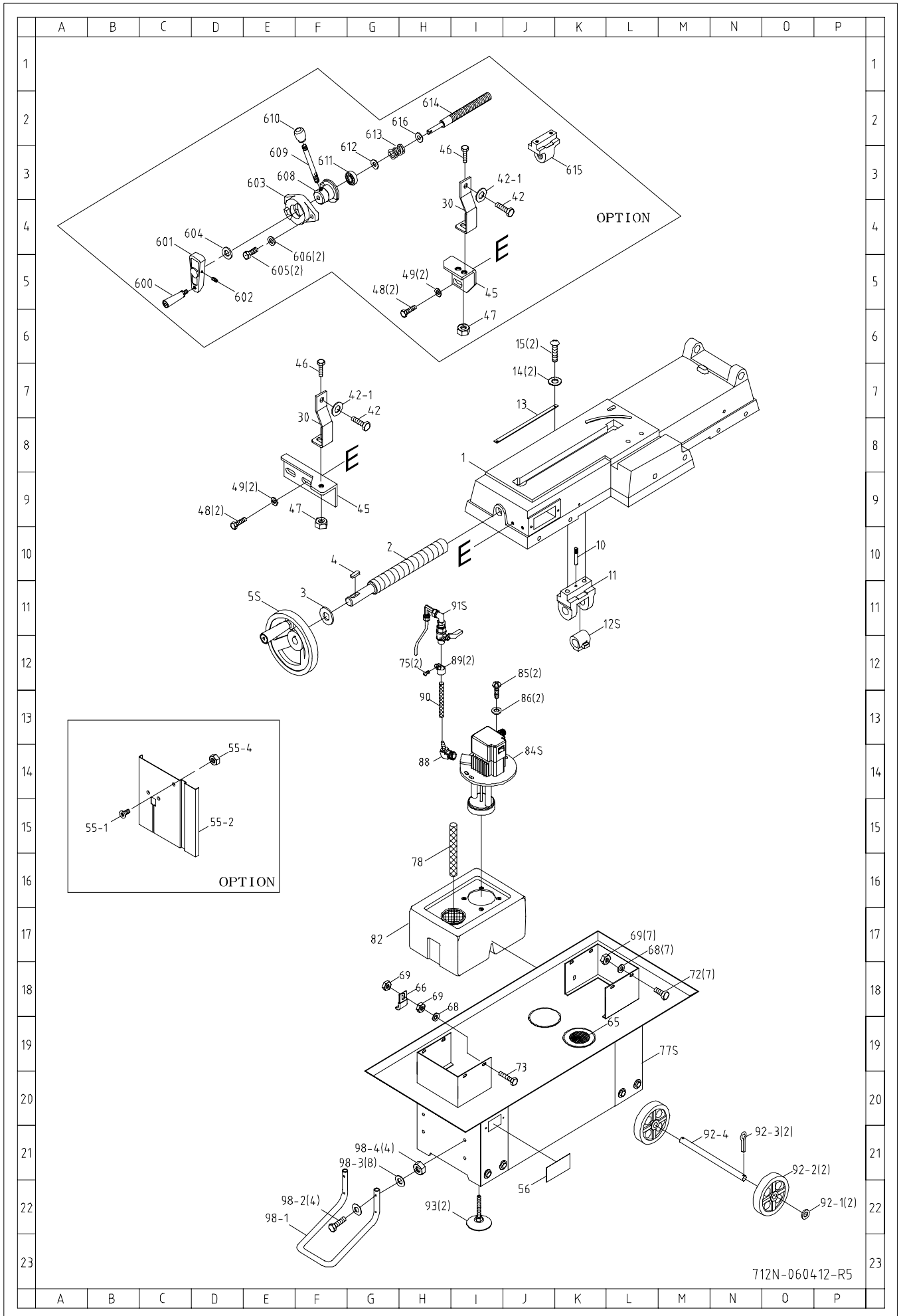

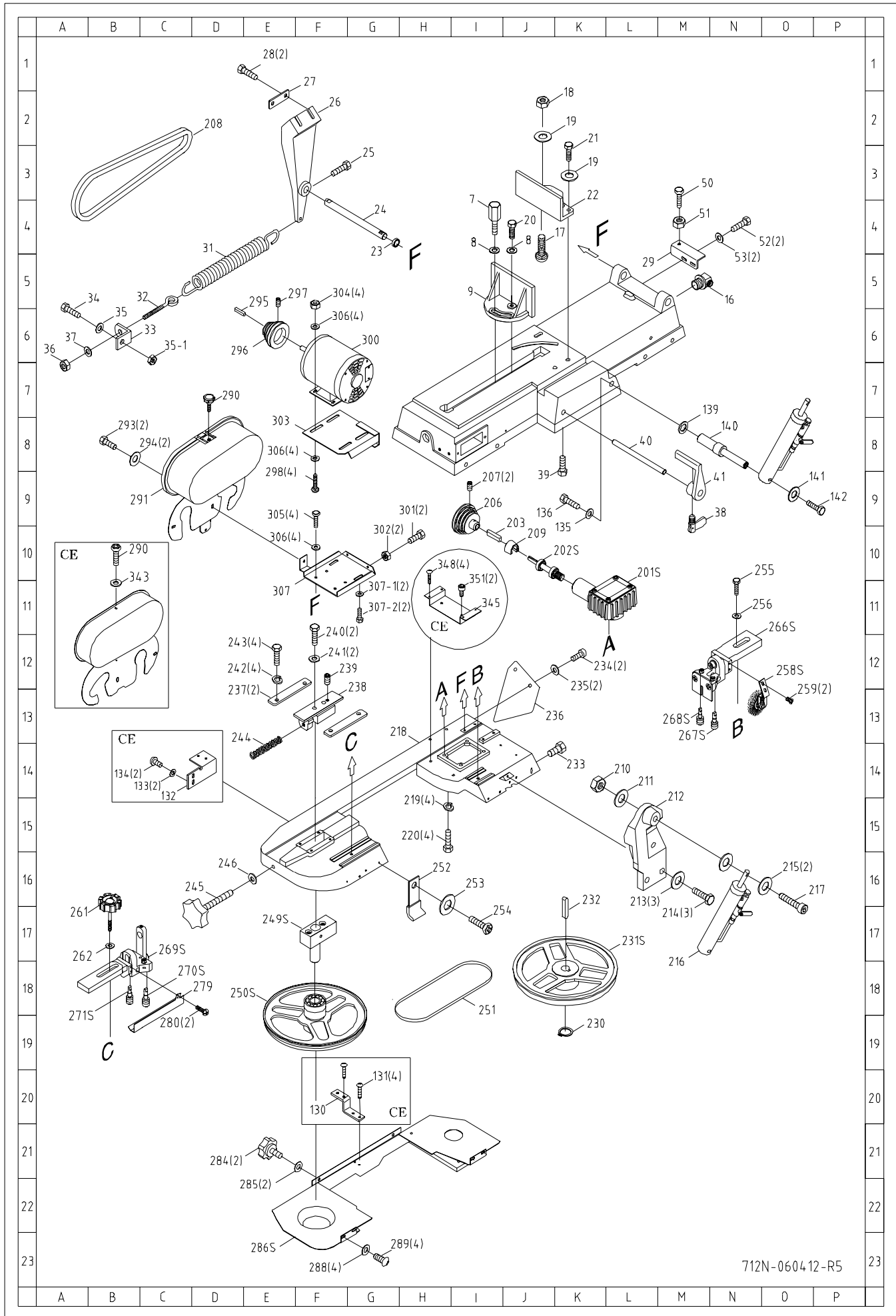

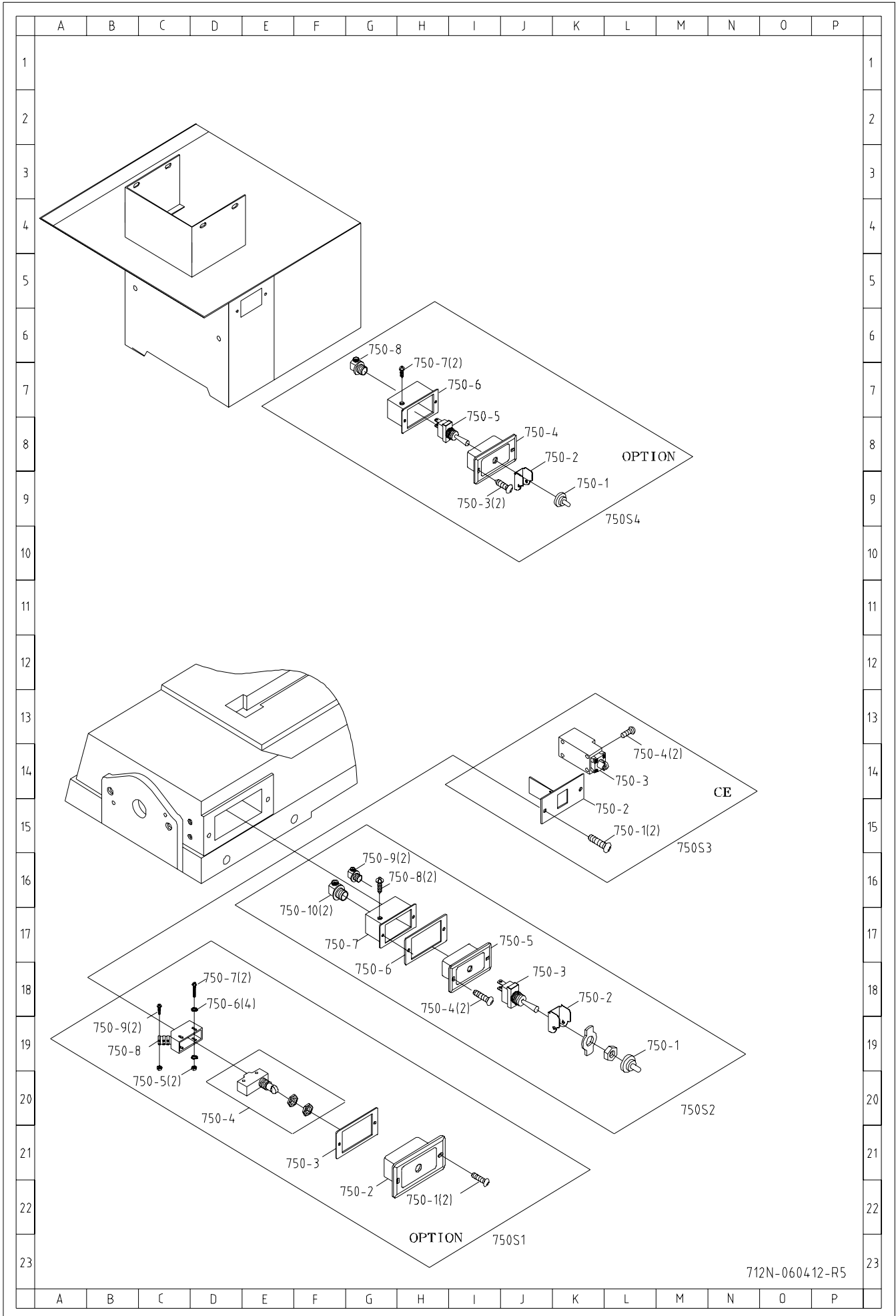

PARTS LIST

MODEL NO. 712N

CODE NO	PART NO	DESCRIPTION	SPECIFICATION	QTY	NOTE
1	181107A	Swivel Base		1	All thread
1	181107-2	Base		1	Semi thread
2	181108E	Acme Screw		1	
3	W002	Washer	1/2"x28xt2	1	
4	K003	Key	5x5x15L	1	
5S	181606S	Wheel		1	
7	181266	Fixed Bolt		1	
8	W008	Washer	3/8"x25xt2	2	
9	181114	Vise Jaw Bracket(Front)		1	
10	HP021	Pin	∅ 5x35L	1	Semi thread
11	181136A	Bracket		1	Semi thread
12S	181604S	Acme Nut Assembly		1	Semi thread
13	181012	Scale		1	
14	W007	Washer	3/16"x12xt0.8	2	
15	S708	Cross Round Head Screw	3/16"x3/8"L	2	
16	ET2108	Wire Nipple	5/8"	1	
17	S501	Carriage Screw	1/2"x2"L	1	
18	N001	Hex. Nut	1/2"	1	
19	W002	Washer	1/2"x28xt2	2	
20	S012	Hex. Head Screw	3/8"x1-1/2"L	1	
21	S003	Hex. Head Screw	1/2"x2"L	1	
22	181113-4	Vise Jaw Bracket(Rear)		1	
23	181121	Bushing		1	
24	181122-1	Support Rod		1	
25	S063	Screw	5/16"x3/4"L	1	
26	181123	Pivot Bracket		1	
27	181270	Washer		1	
28	S012	Hex. Head Screw	3/8"x1-1/2"L	2	
29	181133	Support Plate		1	
30	181134	Fixed Plate		1	
31	181117-1	Spring		1	
32	181118	Spring Adjusting Rod		1	
33	181115	Spring Handle Bracket		1	
34	S022	Hex. Head Screw	5/16"x3/4"L	1	
35	W016	Washer	5/16"x23xt2	1	
35-1	N007	Hex. Nut	5/16"	1	
36	N005	Hex. Nut	3/8"	1	
37	W014	Washer	3/8"x23xt2	1	
38	181130	Thumb Screw		1	
39	S022	Hex. Head Screw	5/16"x3/4"L	1	

PARTS LIST

MODEL NO. 712N

CODE NO	PART NO	DESCRIPTION	SPECIFICATION	QTY	NOTE
40	3021	Stock Stop Rod		1	
41	181125	Stop Block		1	
42	S019	Hex. Head Screw	5/16"x1-1/2"L	1	
42-1	W004	Washer	1/4"x19xt1.5	1	
45	181112	Support Plate		1	Semi thread
45	181112A	Support Plate		1	All thread
46	S014	Hex. Head Screw	3/8"x1-3/4"L	1	
47	N005	Hex. Nut	3/8"	1	
48	S022	Hex. Head Screw	5/16"x3/4"L	2	
49	W017	Washer	5/16"x18xt1.5	2	
50	S014	Hex. Head Screw	3/8"x1-3/4"L	1	
51	N005	Hex. Nut	3/8"	1	
52	S022	Hex. Head Screw	5/16"x3/4"L	2	
53	W017	Washer	5/16"x18xt1.5	2	
55-1	S302	Flat Cross Head Screw	1/4"x3/8"L	1	Option
55-2	3055A	Vertical Saw Table		1	Option
55-4	N003	Hexagon nut	1/4"	1	Option
56	181900	Warning mark		1	
65	191106A	Filter		1	
66	3076	Switch Cut Off Tip		1	
68	W017	Washer	3/8"x18xt1.5	8	
69	N007	Hex. Nut	5/16"	9	
72	S017	Hex. Head Screw	5/16"x1"L	7	
73	S023	Hex. Head Screw	5/16"x1-1/4"L	1	
75	S708	Cross Round Head Screw	3/16"x3/8"L	2	
77S	18110	Stand Complete Assembly		1	
78	181854	Hose	5/8"x200mm	1	
82	181256	Coolant Tank		1	
84S		Pump		1	
85	S717	Cross Round Head Screw	1/4"x5/8"L	2	
86	W004	Washer	1/4"x19xt1.5	2	
88	181852	Coupler	3/8"PTx5/16"	1	
89	181601	Hose Clip	5/8"	2	
90	181981	Hose	OD12xID8x2000	1	
91S	181980	Fitting		1	
92-1	W013	Washer	3/8"	2	
92-2	181129	Wheel		2	
92-3	HP210	Cotter Pin	§ 3x25L	2	
92-4	181128	Wheel Rod		1	
93	181308	Coaster of Stand		2	

PARTS LIST

MODEL NO. 712N

CODE NO	PART NO	DESCRIPTION	SPECIFICATION	QTY	NOTE
98-1	192039	Hand Rod		1	
98-2	S019	Hex. Head Screw	5/16"x1-1/2"L	4	
98-3	W017	Washer	5/16"x18xt1.5	8	
98-4	N007	Hex. Nut	5/16"	4	
130	181306	Bracket		1	For CE Only
130	181306A	Bracket		1	For CE Only (Option)
131	HS508	Cross Round Head Screw	M4x5L	4	For CE Only
132	181305	Switch Base		1	For CE Only
132	181305A	Switch base		1	For CE Only (Option)
133	HW003	Washer	M5	2	For CE Only
134	HW509	Cross Round Head Screw	M4x10L	2	For CE Only
135	W018	Washer	5/16"x23xt3	1	
136	S022	Hex. Head Screw	5/16"x3/4"L	1	
139	181608	Washer		1	
140	181301C	Cylinder Lower Support		1	
141	W016	Washer	5/16"x19xt1.5	1	
142	S018	Hex. Head Screw	5/16"x1/2"L	1	
201S	18121	Gear Box Assembly		1	
202S	18138	Worm Gear Shaft Assembly		1	
203	HK110	Key	5x5x30L	1	
206	181226	Spindle Pulley		1	
207	S604	Hex. Socker Headless Screw	1/4"x3/8"L	2	
208	181874	Belt	3Vx270	1	
209	181237D	Cover		1	
210	N005	Hex. Nut	3/8"	1	
211	W013	Washer	3/8"x20xt2	1	
212	181302-2	Cylinder Upper Support		1	
213	W017	Washer	5/16"x18xt1.5	3	
214	S017	Hex. Head Screw	5/16"x1"L	3	
215	W014	Washer	3/8"x23xt2	2	
216	181304-2	Cylinder Complete Set	RF-712N	1	
217	S412	Hex. Socket Head Screw	3/8"x2-1/4"L	1	
218	181203-1	Body Frame		1	
219	W204	Spring Washer	3/8"	4	
220	S013	Hex. Head Screw	3/8"x1-1/4"L	4	
230	HCS13	C-Retainer Ring	S25	1	
231S	181214-2S	Drive Wheel		1	
232	HK025	Key	6x6x20L	1	
233	S022	Hex. Head Screw	5/16"x3/4"L	1	
234	S201	Cross Socker Hex. Head Screw	1/4"x5/8"L	2	

PARTS LIST

MODEL NO. 712N

CODE NO	PART NO	DESCRIPTION	SPECIFICATION	QTY	NOTE
235	W005	Washer	1/4"x16xt1.5	2	
236	181232-1	Support Plate		1	
237	181210	Sliding Plate		2	
238	181211	Blade Tension Sliding Block		1	
239	S608	Hex. Socker Headless Screw	5/16"x3/4"L	1	
240	S019	Hex. Head Screw	5/16"x1-1/2"L	2	
241	W015	Washer	5/16"x12xt2	2	
242	W205	Spring Washer	5/16"	4	
243	S020	Hex. Head Screw	5/16"x3/4"L	4	
244	181212	Spring		1	
245	181213A	Blade Adjustable Knob		1	
246	W008	Washer	3/8"x25xt2	1	
249S	18122	Shaft Assembly		1	
250S	18123A	Idler Wheel Assembly		1	
251	181894	Blade	0.032"x3/4"x93"x6-10T	1	
251	181894-2	Blade	0.032"x3/4"x93"x6-10T	1	Option
252	181240	Switch Cut Off Tip		1	
253	W005	Washer	1/4"x16xt1.5	1	
254	S201	Cross Socker Hex. Head Screw	1/4"x5/8"L	1	
255	S013	Hex. Head Screw	3/8"x1-1/4"L	1	
256	W008	Washer	3/8"x25xt2	1	
258S	181242BS	Brush Assembly		1	
259	S708	Cross Round Head Screw	3/16"x3/8"L	2	
261	3066-3	Blade Adjustable Knob		1	
262	W008	Washer	3/8"x25xt2	1	
266S	18128A	Adjustable Bracket Assembly (Rear)		1	
267S	18126	Guide Pivot Assembly		1	
268S	18127	Bearing Shaft Assembly		1	
269S	18124K	Adjustable Bracket (Front)		1	
270S	18126	Guide Pivot Assembly		1	
271S	18127	Bearing Shaft Assembly		1	
279	181231	Blade Cover(Front)		1	
280	S711	Cross Round Head Screw	5/32"x1/4"L	2	
284	195083	Plum handle		2	
285	W005	Washer	1/4"x16xt1.5	2	
286S	18137	Blade Back Cover		1	
288	W005	Washer	1/4"x16xt1.5	4	
289	S701	Cross Round Head Screw	1/4"x1/2"L	4	
290	S201	Cross Socker Hex. Head Screw	1/4"x1/2"L	1	For CE Only
290	3058	Plum handle		1	

PARTS LIST

MODEL NO. 712N

CODE NO	PART NO	DESCRIPTION	SPECIFICATION	QTY	NOTE
291	181237I	Motor Pulley Cover		1	
291	18131	Motor Pulley Cover		1	For CE Only
293	S201	Cross Socker Hex. Head Screw	1/4"x5/8"L	2	
294	W004	Washer	1/4"x19xt1.5	2	
295	HK110	Key	5x5x30L	1	
296	181235	Motor Pulley		1	
297	S604	Hex. Socker Headless Screw	1/4"x3/8"L	1	
298	S510	Carriage Screw	5/16"x3/4"L	4	
300		Motor		1	
301	S017	Hex. Head Screw	5/16"x1"L	2	
302	N007	Hex. Nut	5/16"	2	
303	181234A	Motor Mount Plate		1	
304	N007	Hex. Nut	5/16"	4	
305	S022	Hex. Head Screw	5/16"x3/4"L	4	
306	W016	Washer	5/16"x23xt2	12	
307	181233A	Motor Mount Bracket		1	
307-1	W016	Washer	5/16"X23Xt2	2	
307-2	S020	Hex. Head Screw	5/16"X7/8"L	2	
343	W005	Washer	1/4"x16xt1.5	1	For CE Only
345	181991	Emergency Switch Bracket		1	For CE Only
345	181991A	Emergency Switch Bracket		1	For CE Only (Option)
348	S727	Cross Round Head Screw	M6x12L	4	For CE Only
351	S407	Hex. Socket Head Screw	3/16"x3/8"L	2	For CE Only
600	3027-1	Knob		1	All thread
601	193057	Knob		1	All thread
602	S601	Hex. Socker Headless Screw	1/4"x1/2"L	1	All thread
603	193055	Pressure Lump		1	All thread
604	HW007	Washer	§ 12xt2	1	All thread
605	S013	Hex. Head Screw	3/8"x1-1/4"L	2	All thread
606	W013	Washer	3/8"x20xt2	2	All thread
608	193056	Pressure Shaft		1	All thread
609	193059	Knob W/Shaft		1	All thread
610	290086	Plastic Round Knob	VRF31\	1	All thread
611	CA51101	Bearing		1	All thread
612	HW007	Washer	§ 12xt2	1	All thread
613	193058	Spring		1	All thread
614	181108C	Acme Screw		1	All thread
615	181138B	Acme Nut		1	All thread
616	W002	Washer	1/2"x28xt2	1	All thread
750S1	ET1615S	Limit Switch Assembly		1	Option

PARTS LIST

MODEL NO. 712N

CODE NO	PART NO	DESCRIPTION	SPECIFICATION	QTY	NOTE
750-1	S708	Cross Round Head Screw	3/16"x3/8"L	2	Option
750-2	ET1931	Switch Cover		1	Option
750-3	181431	Rubber Plate		1	Option
750-4	ET1615	Limit Switch	MJ1308R	1	Option
750-5	HN002	Hex. Nut	M4	2	Option
750-6	HW305	Star Washer	M4	4	Option
750-7	HS513	Cross Round Head Screw	M4x30L	2	Option
750-8	ET2101	Limit Switch Cover	CB2	1	Option
750-9	HS511	Cross Round Head Screw	M4x20L	2	Option
750S2	ET1403S	Toggle Switch Assembly		1	
750-1	181932	Toggel Switch Cover		1	
750-2	3131B	Switch Cover		1	
750-3	ET1403	Toggle Switch Assembly	1 ¢	1	
750-3	181933	Toggle Switch	3 ¢	1	
750-4	S805	Screw	3/16"x3/8"L	2	
750-5	ET1931	Cover		1	
750-6	181431	Rubber Plate		1	
750-7	ET1930	Electrical Box		1	
750-8	S807	Screw	5/32"x1/8"L	2	
750-9	ET2108	Wire Nipple	5/8"	2	
750-10	ET2107	Wire Nipple	1/2"	2	
750S3	ET1617S	Switch		1	For CE Only
750-1	S708	Cross Round Head Screw	3/16"x3/8"L	2	For CE Only
750-2	181989-1	Switch Bracket		1	For CE Only
750-3	ET1617	Switch		1	For CE Only
750-4	S708	Cross Round Head Screw	3/16"x3/8"L	2	For CE Only
750S4	ET1401S	Toggle Switch Assembly		1	Option
750-1	181932	Toggel Switch Cover		1	Option
750-2	3131B	Switch Cover		1	Option
750-3	S805	Screw	3/16"x3/8"L	2	Option
750-4	ET1931	Cover		1	Option
750-5	ET1401	Toggle Switch Assembly	1 ¢	1	Option
750-5	181933	Toggle Switch Assembly	3 ¢	1	Option
750-6	ET1930	Electrical Box		1	Option
750-7	S807	Screw	5/32"x1/8"L	2	Option
750-8	ET2107	Wire Nipple	1/2"	1	Option

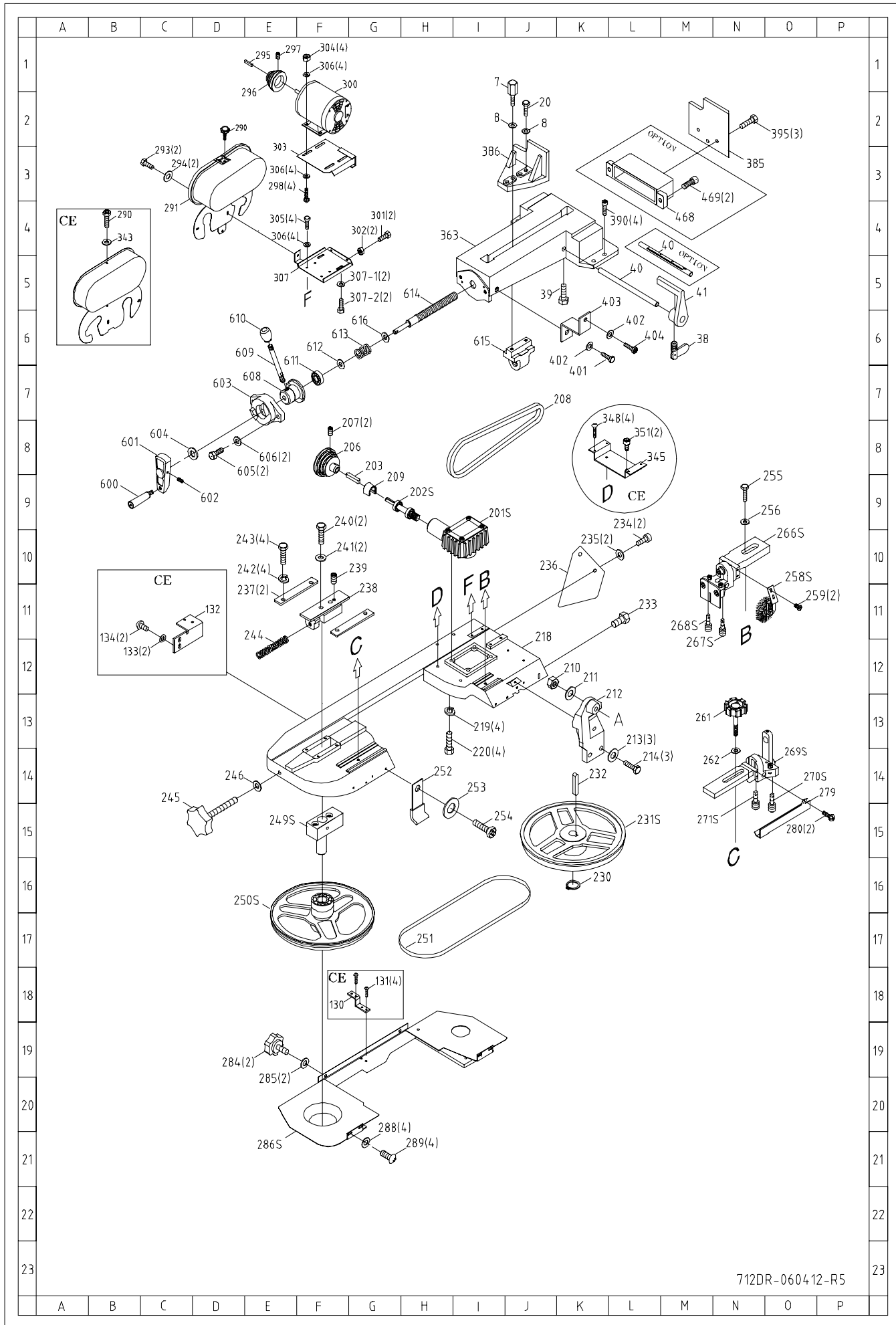

PARTS LIST

MODEL NO. 712DR

CODE NO	PART NO	DESCRIPTION	SPECIFICATION	QTY	NOTE
7	181266	Fixed Bolt		1	
8	W008	Washer	3/8"x25xt2	2	
20	S012	Hex. Head Screw	3/8"x1-1/2"L	1	
23	181121	Bushing		1	
24	181122-1	Support Rod		1	
25	S063	Screw	5/16"x3/4"L	1	
26	181123	Pivot Bracket		1	
27	181270	Washer		1	
28	S012	Hex. Head Screw	3/8"x1-1/2"L	2	
31	182050	Spring		1	
32	182049	Spring Adjusting Screw		1	
33	182003	Spring Bracket		1	
34	S022	Hex. Head Screw	5/16"x3/4"L	1	
35	W016	Washer	5/16"x23xt2	1	
36	N005	Hex. Nut	3/8"	1	
37	W014	Washer	3/8"x23xt2	1	
38	181130	Thumb Screw		1	
39	S022	Hex. Head Screw	5/16"x3/4"L	1	
40	3021	Stock Stop Rod		1	
40	3021A	Stock Stop Rod		1	Option
41	181125	Stop Block		1	
65	191106A	Filter		1	
75	S708	Cross Round Head Screw	3/16"x3/8"L	2	
76	S006	Hex. Head Screw	1/4"-20*1/2"L	1	
77S	182028ES	Stand Complete Assembly		1	
77-1	182028E1-1	Stand Leg(Right)(Left)		2	
77-2	182028E1-2	Stand Leg (front)		1	
77-3	182028E1-3	Stand Leg (Back)		1	
77-4	182028E1-4	Middle Plate of Stand		1	
77-5	182028E	Chip Pan		1	
77-6	HS242	Hex. Socket Head Screw	M8-1.25Px20L	11	
77-7	HW005	Washer	8.5*18-1.6t (M8)	21	
77-8	HN005	Hex. Nut	M8	10	
77-9	195058	Rubber Washer	φ 11*22-2	4	
77-10	HS242	Hex. Socket Head Screw	M8-1.25Px20L	4	
77-11	W015	Washer	M8x23xt2	4	
77-12	HS058	Hex. Head Screw	M10X20L	4	
77-13	HW006	Washer	M10X20Xt2	4	
77-14	HO028	O-Retainer Ring	φ 2x φ 10	4	
78	182076	Hose	3/4"x200mm	1	
82	181256	Coolant Tank		1	

PARTS LIST

MODEL NO. 712DR

CODE NO	PART NO	DESCRIPTION	SPECIFICATION	QTY	NOTE
84S		Pump		1	
85	S717	Cross Round Head Screw	1/4"x5/8"L	2	
86	W004	Washer	1/4"x19xt1.5	2	
88	181852	Coupler	3/8"PTx5/16"	1	
89	181601	Hose Clip	5/8"	2	
90	181981	Hose	OD12xID8x2000	1	
97	182042	Cylinder Complete Set		1	
101	S412	Hex. Socket Head Screw	3/8"x2-1/4"L	1	
102	W014	Washer	3/8"x23xt2	2	
123	193046	Power Cutting Bracket		1	
124	W007	Washer	M5	2	
125	S721	Cross Round Head Screw	M5x10L	2	
130	181306	Bracket		1	For CE Only
130	181306A	Bracket		1	For CE Only (Option)
131	HS508	Cross Round Head Screw	M4x5L	4	For CE Only
132	181305	Switch Base		1	For CE Only
132	181305A	Switch base		1	For CE Only (Option)
133	HW003	Washer	M5	2	For CE Only
134	HW509	Cross Round Head Screw	M4x10L	2	For CE Only
201S	18121	Gear Box Assembly		1	
202S	18138	Worm Gear Shaft Assembly		1	
203	HK110	Key	5x5x30L	1	
206	181226B	Spindle Pulley		1	
207	S604	Hex. Socker Headless Screw	1/4"x3/8"L	2	
208	181874	Belt	3Vx270	1	
209	181237D	Cover		1	
210	N005	Hex. Nut	3/8"	1	
211	W013	Washer	3/8"x20xt2	1	
212	181302-2	Cylinder Upper Support		1	
213	W017	Washer	5/16"x18xt1.5	3	
214	S017	Hex. Head Screw	5/16"x1"L	3	
218	181203-1	Body Frame		1	
219	W204	Spring Washer	3/8"	4	
220	S013	Hex. Head Screw	3/8"x1-1/4"L	4	
230	HCS13	C-Retainer Ring	S25	1	
231S	181214-2S	Drive Wheel		1	
232	HK025	Key	6x6x20L	1	
233	S022	Hex. Head Screw	5/16"x3/4"L	1	
234	S201	Cross Socker Hex. Head Screw	1/4"x5/8"L	2	
235	W005	Washer	1/4"x16xt1.5	2	
236	181232-1	Support Plate		1	

PARTS LIST

MODEL NO. 712DR

CODE NO	PART NO	DESCRIPTION	SPECIFICATION	QTY	NOTE
237	181210	Sliding Plate		2	
238	181211	Blade Tension Sliding Block		1	
239	S608	Hex. Socker Headless Screw	5/16"x3/4"L	1	
240	S019	Hex. Head Screw	5/16"x1-1/2"L	2	
241	W015	Washer	5/16"x12xt2	2	
242	W205	Spring Washer	5/16"	4	
243	S020	Hex. Head Screw	5/16"x3/4"L	4	
244	181212	Spring		1	
245	181213A	Blade Adjustable Knob		1	
246	W008	Washer	3/8"x25xt2	1	
249S	18122	Shaft Assembly		1	
250S	18123A	Idler Wheel Assembly		1	
251	181894-2	Blade	0.032"x3/4"x93"x6-10T	1	
252	181240	Switch Cut Off Tip		1	
253	W005	Washer	1/4"x16xt1.5	1	
254	S201	Cross Socker Hex. Head Screw	1/4"x5/8"L	1	
255	S013	Hex. Head Screw	3/8"x1-1/4"L	1	
256	W008	Washer	3/8"x25xt2	1	
258S	181242BS	Brush Assembly		1	
259	S708	Cross Round Head Screw	3/16"x3/8"L	2	
261	3066-3	Blade Adjustable Knob		1	
262	W008	Washer	3/8"x25xt2	1	
266S	18128A	Adjustable Bracket Assembly (Rear)		1	
267S	18126	Guide Pivot Assembly		1	
268S	18127	Bearing Shaft Assembly		1	
269S	18124K	Adjustable Bracket (Front)		1	
270S	18126	Guide Pivot Assembly		1	
271S	18127	Bearing Shaft Assembly		1	
279	181231	Blade Cover(Front)		1	
280	S711	Cross Round Head Screw	5/32"x1/4"L	2	
284	195083	Plum handle		2	
285	W005	Washer	1/4"x16xt1.5	2	
286S	18137	Blade Back Cover		1	
288	W005	Washer	1/4"x16xt1.5	4	
289	S701	Cross Round Head Screw	1/4"x1/2"L	4	
290	S201	Cross Socker Hex. Head Screw	1/4"x1/2"L	1	For CE Only
290	3058	Plum handle		1	
291	181237I	Motor Pulley Cover		1	
293	S201	Cross Socker Hex. Head Screw	1/4"x5/8"L	2	
294	W004	Washer	1/4"x19xt1.5	2	
295	HK110	Key	5x5x30L	1	

PARTS LIST

MODEL NO. 712DR

CODE NO	PART NO	DESCRIPTION	SPECIFICATION	QTY	NOTE
296	181235B	Motor Pulley		1	
297	S604	Hex. Socker Headless Screw	1/4"x3/8"L	1	
298	S510	Carriage Screw	5/16"x3/4"L	4	
300		Motor		1	
301	S017	Hex. Head Screw	5/16"x1"L	2	
302	N007	Hex. Nut	5/16"	2	
303	181234A	Motor Mount Plate		1	
304	N007	Hex. Nut	5/16"	4	
305	S022	Hex. Head Screw	5/16"x3/4"L	4	
306	W016	Washer	5/16"x23xt2	12	
307	181233A	Motor Mount Bracket		1	
307-1	W016	Washer	5/16"X23Xt2	2	
307-2	S020	Hex. Head Screw	5/16"X7/8"L	2	
343	W005	Washer	1/4"x16xt1.5	1	For CE Only
345	181991	Emergency Switch Bracket		1	For CE Only
345	181998	Emergency Switch Bracket		1	For CE Only (Option)
348	S727	Cross Round Head Screw	M6x12L	4	For CE Only
351	S407	Hex. Socket Head Screw	3/16"x3/8"L	2	For CE Only
352	W016	Washer	5/16"x19xt1.5	1	
353	S018	Hex. Head Screw	5/16"x1/2"L	1	
360	182020D	Swivel Arm		1	
362	182017B	Swivel Base		1	
363	182044A	Vise Base		1	
367	193032	Bolt	1/2"x2-1/2"L	1	
368	N001	Hex. Nut	1/2"	1	
371	193010	Fixed Shaft		1	
371-1	W204	Spring Washer	3/8"	4	
371-2	S410	Hex. Socket Head Screw	3/8"x1-1/2"L	4	
377	W017	Washer	5/16"x18xt1.5	2	
378	S022	Hex. Head Screw	5/16"x3/4"L	2	
382	182004A	Bracket		1	
385	182043	Vise Jaw Bracket(Rear)		1	
386	182016	Vise Jaw Bracket(Front)		1	
387S	182041S	Cap		1	
389	S416	Hex. Socket Head Screw	M8x25L	6	
390	S425	Hex. Socket Head Screw	M10x30L	4	
392	1976015	Meter Indicator		1	
394	182045	Cylinder Lower Support		1	
395	S023	Hex. Head Screw	5/16"x1-1/4"L	3	
396	S013	Hex. Head Screw	5/16"x1-1/4"L	1	
397	N007	Hex. Nut	5/16"	1	

PARTS LIST

MODEL NO. 712DR

CODE NO	PART NO	DESCRIPTION	SPECIFICATION	QTY	NOTE
399	182014A	Degree-Meter		1	
401	S063	Screw	5/16"x3/4"L	1	
402	W016	Washer	5/16"x23xt2	2	
403	182024	Fixed Plate		1	
404	S206	Hex. Head Screw	5/16"x3/4"L	1	
427	182047	Fix Block		2	
437	182060	Swivel Arm Briquette		1	
438	191210A	Knob		1	
439	W204	Spring Washer	3/8"	1	
440	182061A	Splash Board		1	
441	S732	Cross Round Head Screw	5/16"x1/2"L	2	
443	193029	Protractor Locating Bracket		1	
444	S015	Hexagon head screw	3/8"x2"L	1	
445	N005	Hex. Nut	3/8"	1	
446	193030	Protractor Locating Block		1	
447	S415	Hexagon screw	5/16"x1/2"L	2	
448	103026	Bearing Pin		1	
449	S007	Hex. Socket Head Screw	1/4"x1-1/4"L	4	
450	S015	Hexagon head screw	3/8"x2"L	2	
451	N005	Hex. Nut	3/8"	2	
452	193025	Swivel Locating Block		2	
468	182065	Extension Base		1	
469	S476	Hex. Socket Head Screw	3/8"x1-1/4"	2	
474	ET2135	Snap Bushing		4	
600	3027-1	Knob		1	All thread
601	193057	Knob		1	All thread
602	S601	Hex. Socker Headless Screw	1/4"x1/2"L	1	All thread
603	193055	Presure Lump		1	All thread
604	HW007	Washer	φ 12xt2	1	All thread
605	S013	Hex. Head Screw	3/8"x1-1/4"L	2	All thread
606	W013	Washer	3/8"x20xt2	2	All thread
608	193056	Presure Shaft		1	All thread
609	193059	Knob W/Shaft		1	All thread
610	290086	Plastic Round Knob		1	All thread
611	CA51101	Bearing		1	All thread
612	HW007	Washer	φ 12xt2	1	All thread
613	193058	Spring		1	All thread
614	182037B	Acme Screw		1	All thread
615	181138B	Acme Nut		1	All thread
616	W002	Washer	1/2"x28xt2	1	All thread

	A	B	C	D	E	F	G	H	I	J	K	L	M	N	O	P	
1																	1
2																	2
3																	3
4																	4
5																	5
6																	6
7																	7
8																	8
9																	9
10																	10
11																	11
12																	12
13																	13
14																	14
15																	15
16																	16
17																	17
18																	18
19																	19
20																	20
21																	21
22																	22
23																	23
	A	B	C	D	E	F	G	H	I	J	K	L	M	N	O	P	

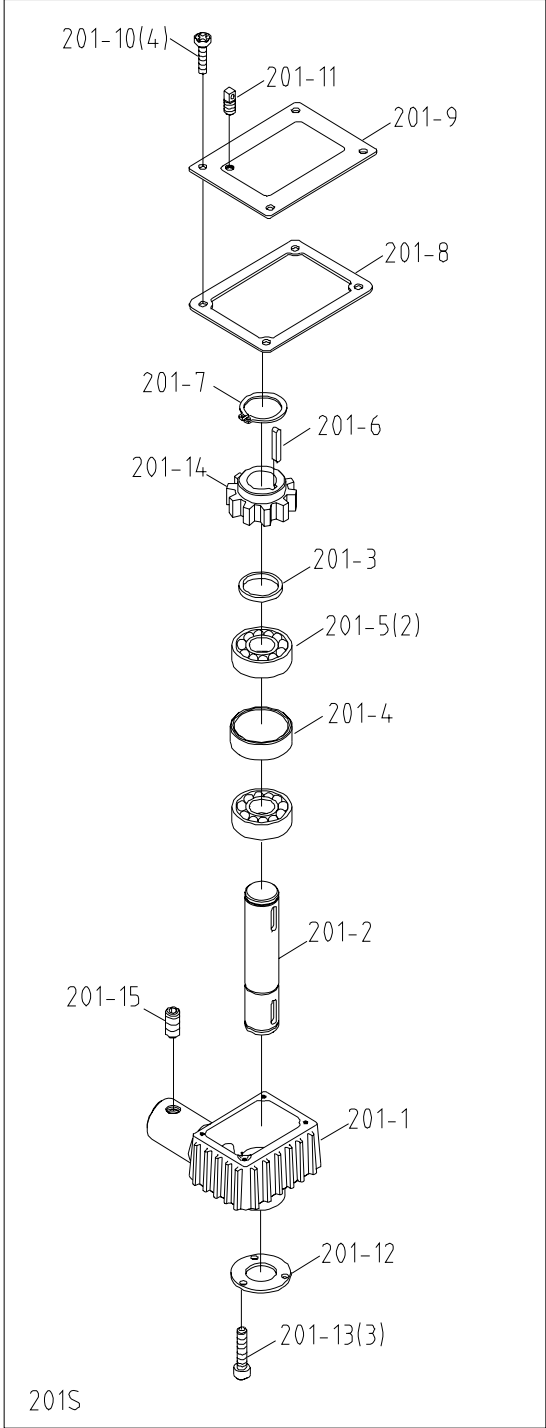
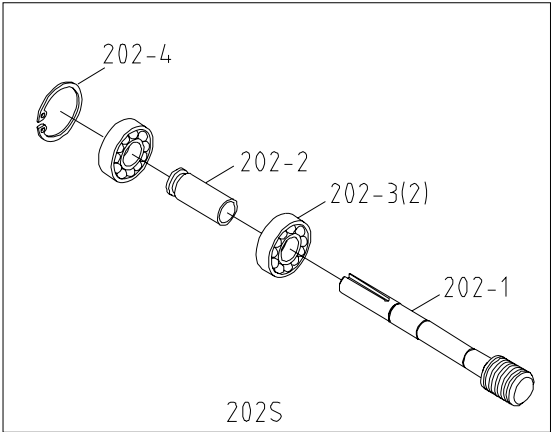

PARTS LIST

MODEL NO. 712N-DR

CODE NO	PART NO	DESCRIPTION	SPECIFICATION	QTY	NOTE
201-1	181216A	Gear Box		1	
201-2	181219-1	Transmission Wheel Shaft		1	
201-3	181218-1	Bushing		1	
201-4	181217-1	Bushing		1	
201-5	CA6205LLU	Bearing	6205LLU	2	
201-6	HK025	Key	6x6x20L	1	
201-7	HCS13	C-Retainer Ring	S25	1	
201-8	3092	Gear Box Gasket		1	
201-9	181222-1	Gear Box Cover		1	
201-10	S201	Cross Socker Hex. Head Screw	1/4"x5/8"L	4	
201-11	3149	Vent Plug	M8xP1	1	
201-12	181246	Bearing Cover		1	
201-13	S708	Cross Round Head Screw	3/16"x3/8"L	3	
201-14	181220-1	Worm Gear		1	
201-15	S607	Hex. Socker Headless Screw	5/16"x1/2"L	1	
202-1	181223	Worm Shaft		1	
202-2	181224	Bearing Bushing		1	
202-3	CA6003LLU	Bearing	6003LLU	2	
202-4	HCS06	C-Retainer Ring	S17	1	
250-1	181205-2	Idler Wheel		1	
250-2	181207-1	Bushing		1	
250-3	HCR04	C-Retainer Ring	R35	1	
250-4	CA6202ZZ	Ball Bearing	6202ZZ	2	
250-5	181245	Bushing		1	
250-6	3072-2	Bearing Cover		1	
250-7	S302	Flat Cross Head Screw	3/16"x3/8"L	3	
250-8	W018	Washer	5/16"x20xt3	1	
250-9	S022	Hex. Head Screw	5/16"x3/4"L	1	
266-1	181228A	Adjustable Bracket(Rear)		1	
266-2	3064	Blade Adjustable (Rear)		1	
266-3	3069	Deflector Plate		1	
266-4	W017	Washer	5/16"x18xt1.5	1	
266-5	W205	Spring Washer	5/16"	1	
266-6	S416	Hex. Socket Head Screw	5/16"x1-1/4"L	1	
266-7	S301	Flat Cross Head Screw	1/4"x1/2"L	2	
266-8	N006	Hex. Nut	3/8"UNF	2	
266-9	W204	Spring Washer	3/8"	2	
266-10	CA6000ZZ	Bearing	6000ZZ	1	
266-11	3063	Bearing Pin		1	
267-1	181244	Guide Pivot		1	

PARTS LIST

MODEL NO. 712N-DR

CODE NO	PART NO	DESCRIPTION	SPECIFICATION	QTY	NOTE
267-2	CA6000ZZ	Bearing	6000ZZ	2	
267-3	HCS01	C-Retainer Ring	S10	1	
268-1	181243	Bearing Shaft		1	
268-2	CA6000ZZ	Bearing	6000ZZ	2	
268-3	HCS01	C-Retainer Ring	S10	1	
269-1	181230-1	Adjustable Bracket(Front)		1	
269-2	181271	Blade Adjustable (Front)		1	
269-3	3063	Bearing Pin		1	
269-4	CA6000ZZ	Bearing	6000ZZ	1	Option
269-5	N006	Hex. Nut	3/8"UNF	2	
269-6	W204	Spring Washer	3/8"	2	
269-7	S604	Hex. Socker Headless Screw	1/4"x3/8"L	1	
269-8	0162	Nozzle Cock Support		1	
269-9	S416	Hex. Socket Head Screw	5/16"x1-1/4"L	1	
270-1	181244	Guide Pivot (Right)		1	
270-2	CA6000ZZ	Bearing	6000ZZ	2	
270-3	HCS01	C-Retainer Ring	S10	1	
271-1	181243	Bearing Shaft		1	
271-2	CA6000ZZ	Bearing	6000ZZ	2	
271-3	HCS01	C-Retainer Ring	S10	1	

MANUFACTURER:

ADDRESS:

SERIAL No.:

PLEASE WRITE DOWN THE SERIAL NO. ON THIS BLOCK FROM THE NAME
PLATE AFTER YOU RECEIVE THIS MACHINE.