

BRAVE

M1158290A

Valve kit for
HBHS300GX and HBHS310GX

Owner's Manual

Instructions for Assembly

Valve Kit: Accessory for Brave Hydraulic Power Packs

About your Valve Kit

The Valve Kit is an ideal choice for a frame mounted 3-position 4-way directional control valve with integral relief valve. The valve kit mounts easily to the pre-drilled holes in the upright bracket assembly, makes plumbing simple, and has a clean finished look.

Any Questions, Comments, Problems or Parts Orders

Call Brave Product Support 1-800-350-8739

Installation Instructions

Kit Contents

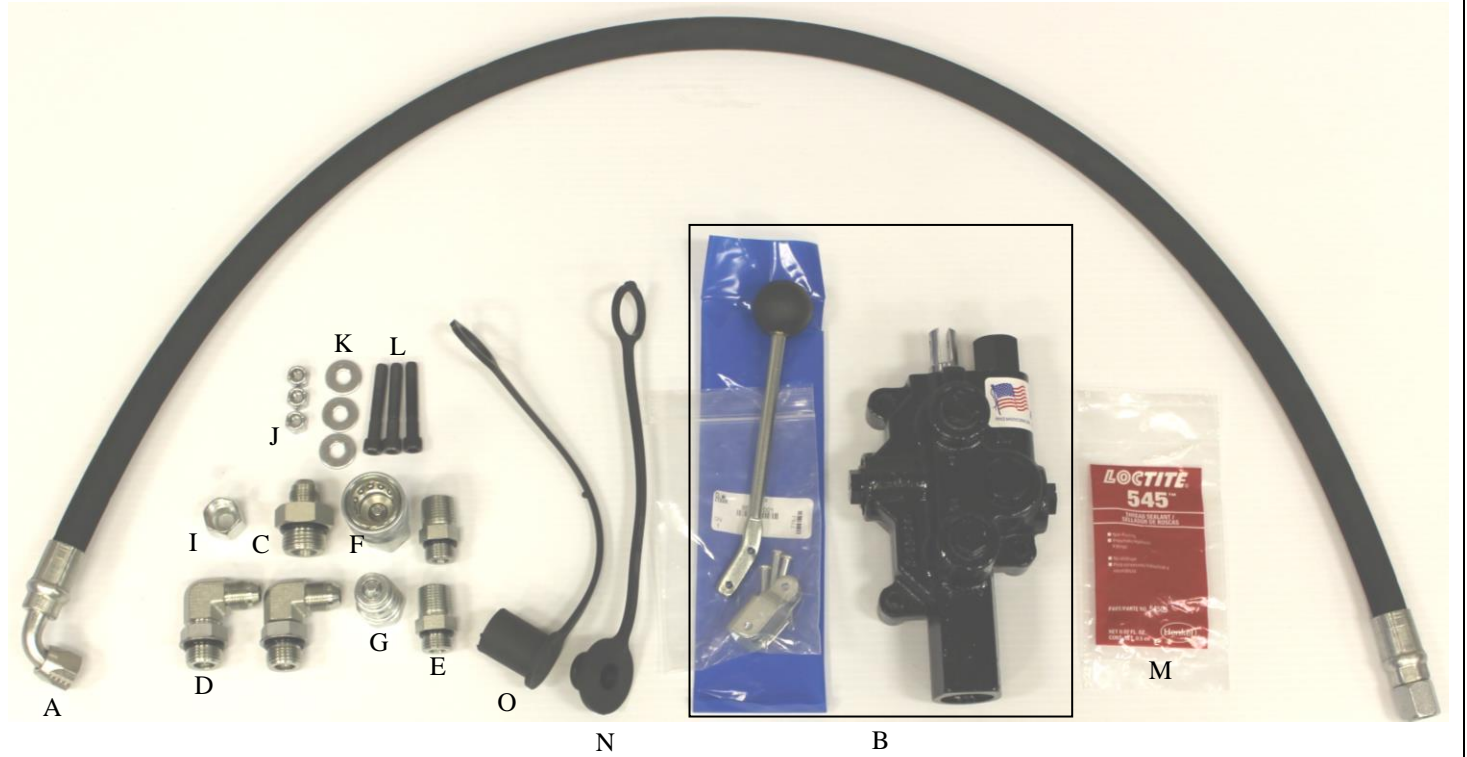

REF	ITEM #	DESCRIPTION	QTY
A	1157989	Return Hose	1
B	1159418	Valve, 2000 PSI (for kit# 1158290 only)	1
	1159901	Valve, 3000 PSI (for kit# 1158292 only)	1
	1082100	Valve Handle Kit	1
C	1013940	Filter Head Adapter Fitting	1
D	1014312	Elbow Fitting	2
E	1014003	Adapter Fitting	2
F	1085800	Female Quick Disconnect Fitting	1
G	1085801	Male Quick Disconnect Fitting	1
I	1013500	JIC Cap	1
J	1014985	Locknut	3
K	1015066	Washer	3
L	1015062	Allen Bolt	3
M	1159341	Thread Sealant	1
N	1081058	Dust Plug	1
O	1081070	Dust Cap	1

Installation Instructions

Step 1 – Engine off / relieve pressure

Perform all installations with the engine off and hydraulic system pressure relieved.

- Make sure engine is off and cool.
- Disconnect the spark plug.
- Relieve system pressure by moving any valve control levers back and forth several times (if applicable).
- Disconnect any installed implements so that unit is configured as it was when originally purchased (do not uninstall parts installed as part of initial assembly).

Tools Needed

- None

WARNING

ALWAYS shut off the engine, disconnect the spark plug, and relieve system pressure before inspecting, cleaning, adjusting, or repairing the unit. Relieve system pressure by moving Valve Control Lever back and forth several times (if applicable).

Installation Instructions

Step 2

- Lubricate O-rings and threads on elbow fittings with clean oil.
- Looking at fittings from end with nut/washer/O-ring assembly, turn nut clockwise as far as possible.
- Using wrench, turn elbow fittings into the IN and OUT ports of the valve. Continue turning until washer touches thread nearest wrench pad.
- Back off fittings counterclockwise not exceeding one revolution until they are oriented as shown.
- Install valve to frame with supplied (3) Allen bolts, with washers and locknuts on inside of frame. Tighten securely.
- Place wrench on the wrench pad of fitting to prevent fitting from turning and torque nut to 70-87 ft.-lb.

Tools Needed

- Adjustable Wrenches
- 1-1/4 Crowfoot Wrench
- Torque Wrench

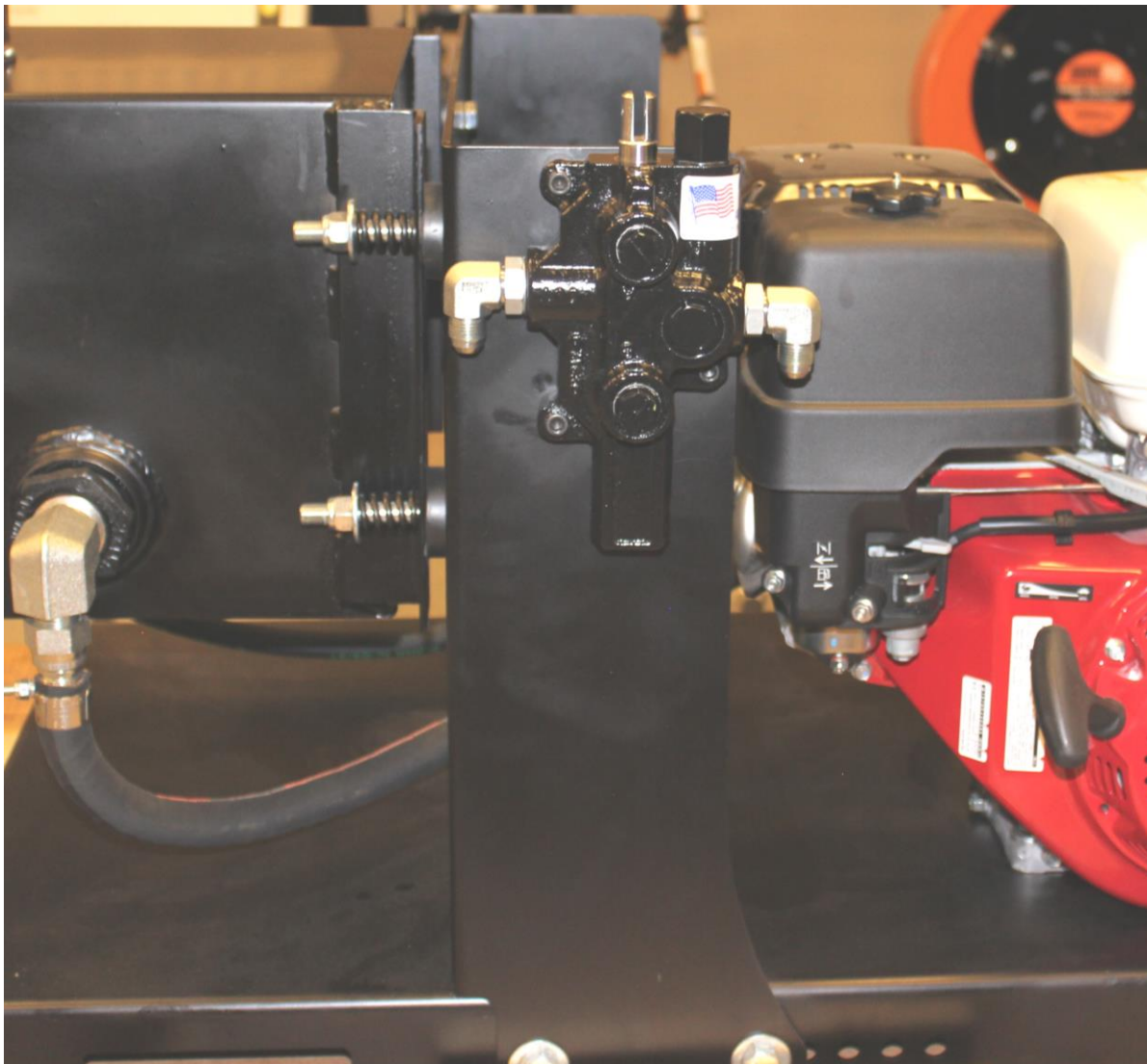

Installation Instructions

Step 3

- Remove relief hose on relief body and replace by hand with JIC cap. Wrench tighten 1/4 turn past hand-tight.

Tools Needed

- Adjustable Wrench

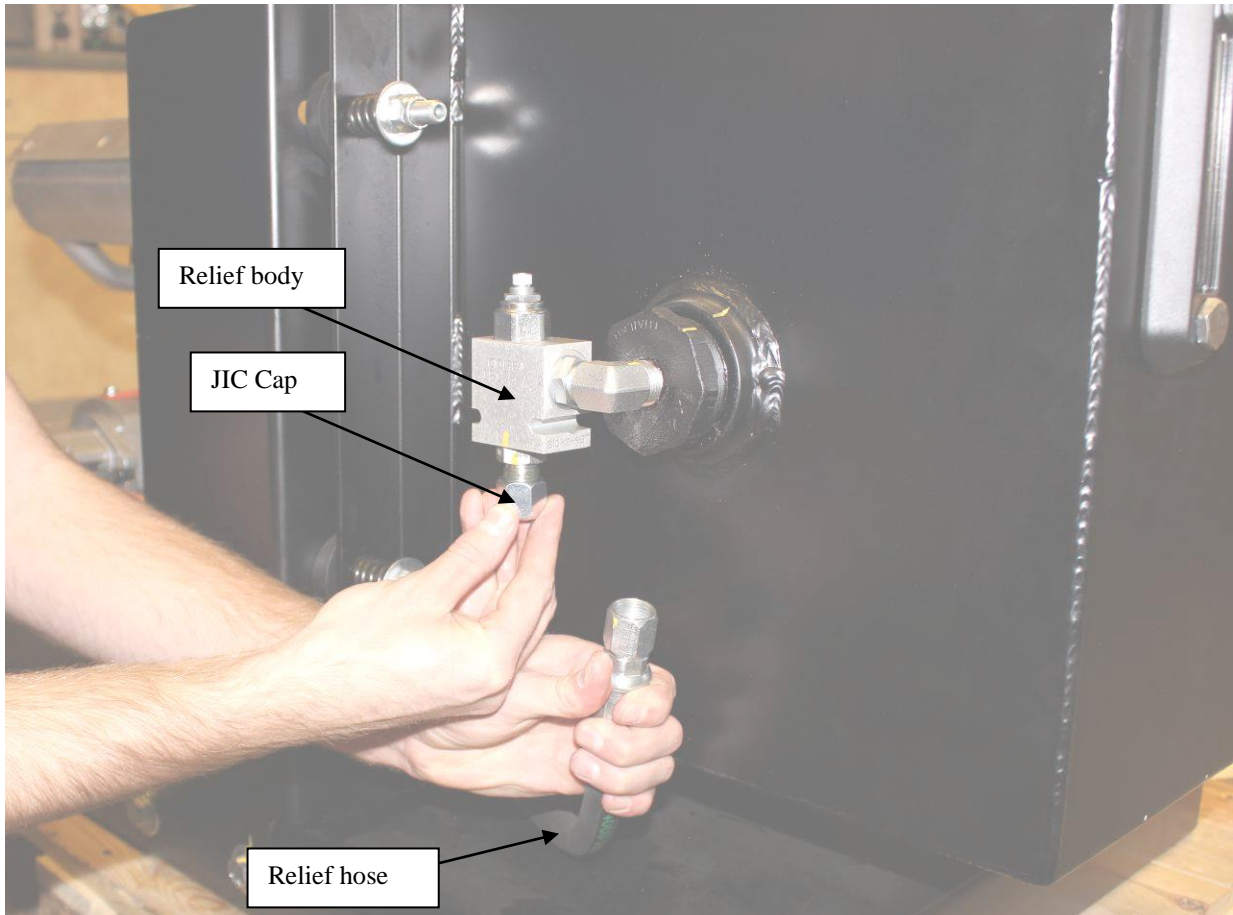

Installation Instructions

Step 4

- Reroute relief hose to valve inlet and thread to elbow fitting by hand. Wrench tighten 1/4 turn past hand-tight.

Tools Needed

- Adjustable Wrench

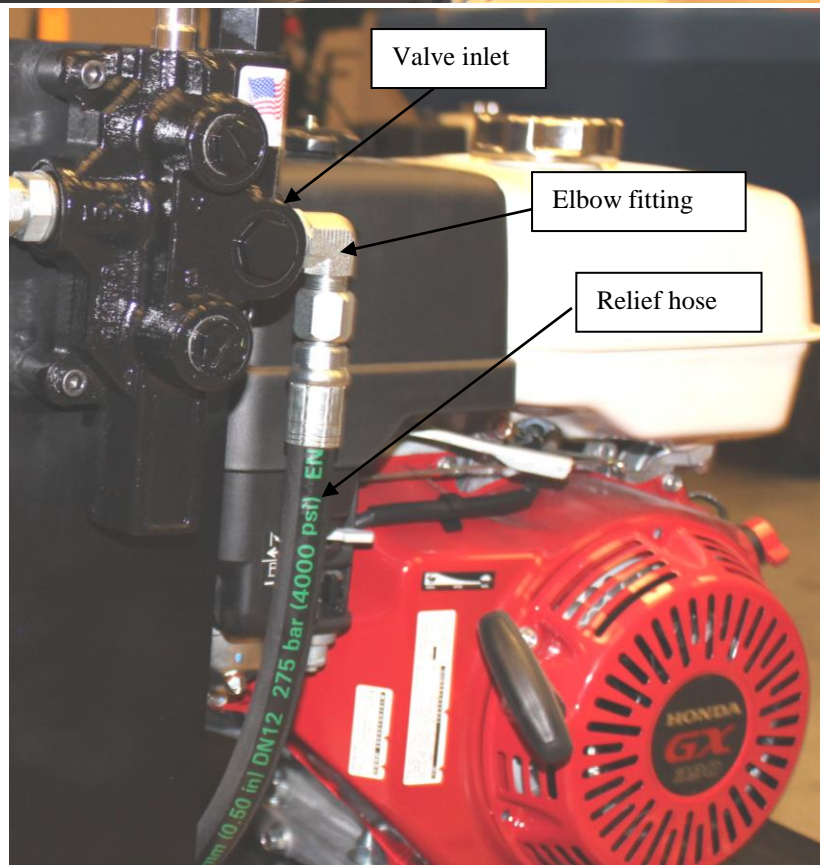
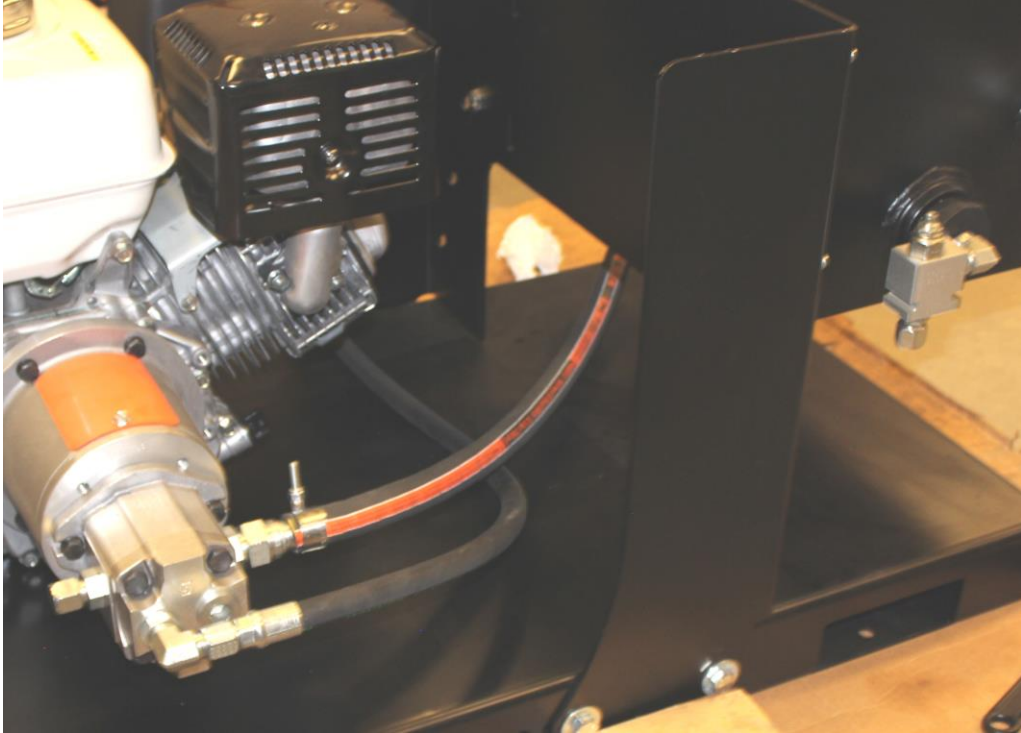

Installation Instructions

Step 5

- Install filter head adapter fitting and torque to 45-57 ft.-lb.
- Thread 90-degree end of return hose to filter head adapter fitting by hand. Hold adapter fitting and wrench tighten hose fitting 1/4 turn past hand-tight.

Tools Needed

- Adjustable Wrench
- 1-1/4 Crowfoot Wrench
- Torque Wrench

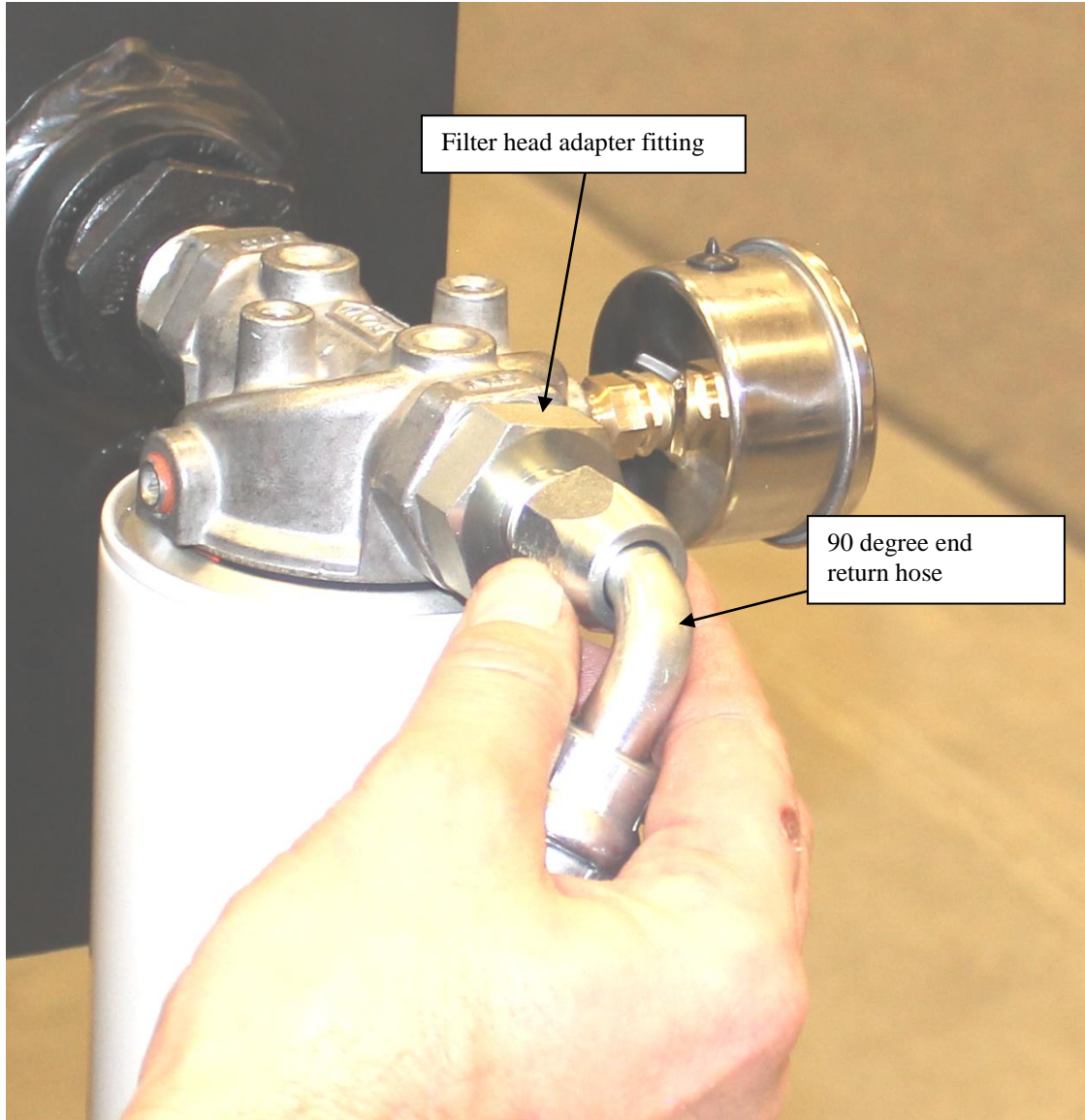

Installation Instructions

Step 6

- Route return hose to valve outlet and thread to elbow fitting by hand. Wrench tighten 1/4 turn past hand-tight.

Tools Needed

- Adjustable wrench

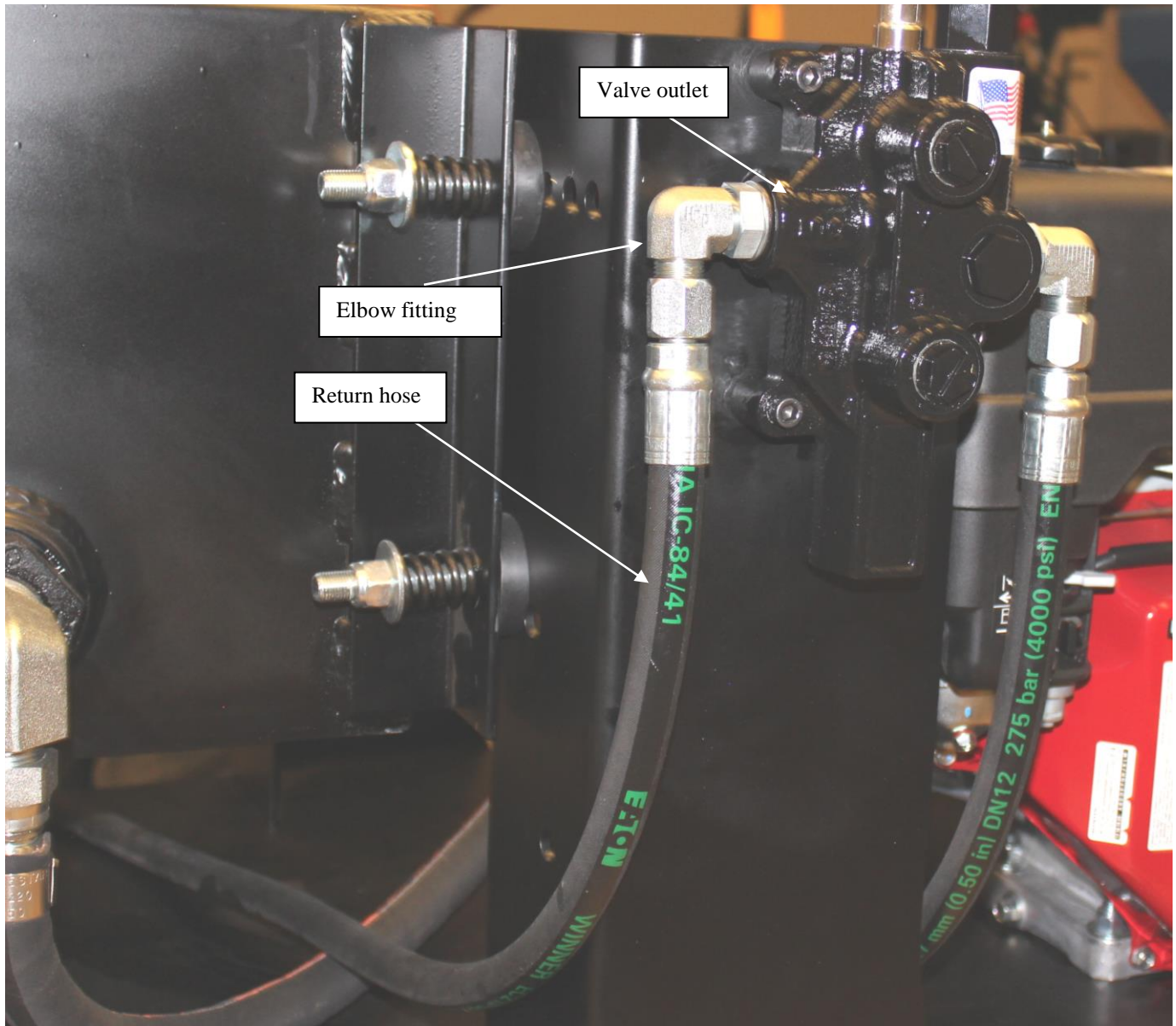

Installation Instructions

Step 7 – Handle to Control Valve

- Locate valve on unit.
- Slide clevis onto valve body, insert pins, and secure with supplied cotter pins.
- Slide control valve handle into the clevis slots on control valve.
- Align holes in handle with clevis holes.
- Insert the supplied pins through holes and secure with supplied cotter pins.

Tools Needed

- Pliers

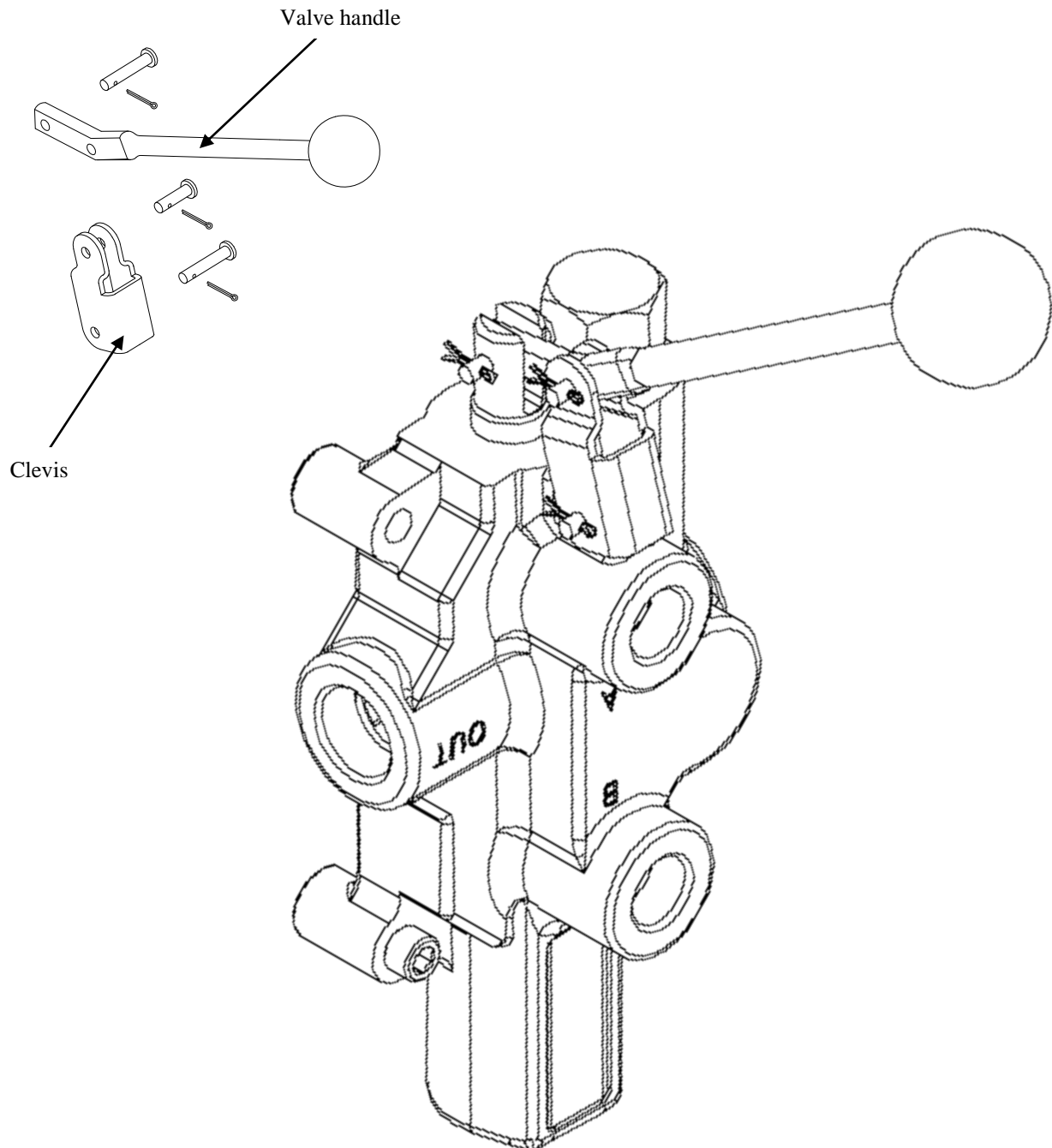

Installation Instructions

Step 8 – Install fittings

- Install fittings in order shown to ports as indicated by A and B.
- Thread O-ring side of adapter fittings into the valve ports A and B finger tight.
- Torque fittings to valve at 37-46 ft.-lb.
- Slip rubber straps of dust plug and cap over adapter fittings.
- CAUTION: Never back off an installed pipe fitting to achieve proper alignment. Loosening installed pipe fittings will corrupt the seal and contribute to leakage and failure.
- Apply thread sealant and screw finger-tight (2) quick disconnect fittings onto the fittings installed into valve A and B ports. Which fitting is attached to which port is up to the customer. Please refer to owner's manual to determine direction of flow and desired configuration of quick disconnect fittings.
- Hold adapter fitting and wrench-tighten the quick disconnect fitting to 1.5-3.0 Turns Past Finger Tight position. Properly assembled fittings total thread engagement should be 3.5-6 turns.
- Press plug/cap into place.

Tools Needed

- Adjustable wrench
- 7/8 Deep Socket
- Torque Wrench
- Ratchet

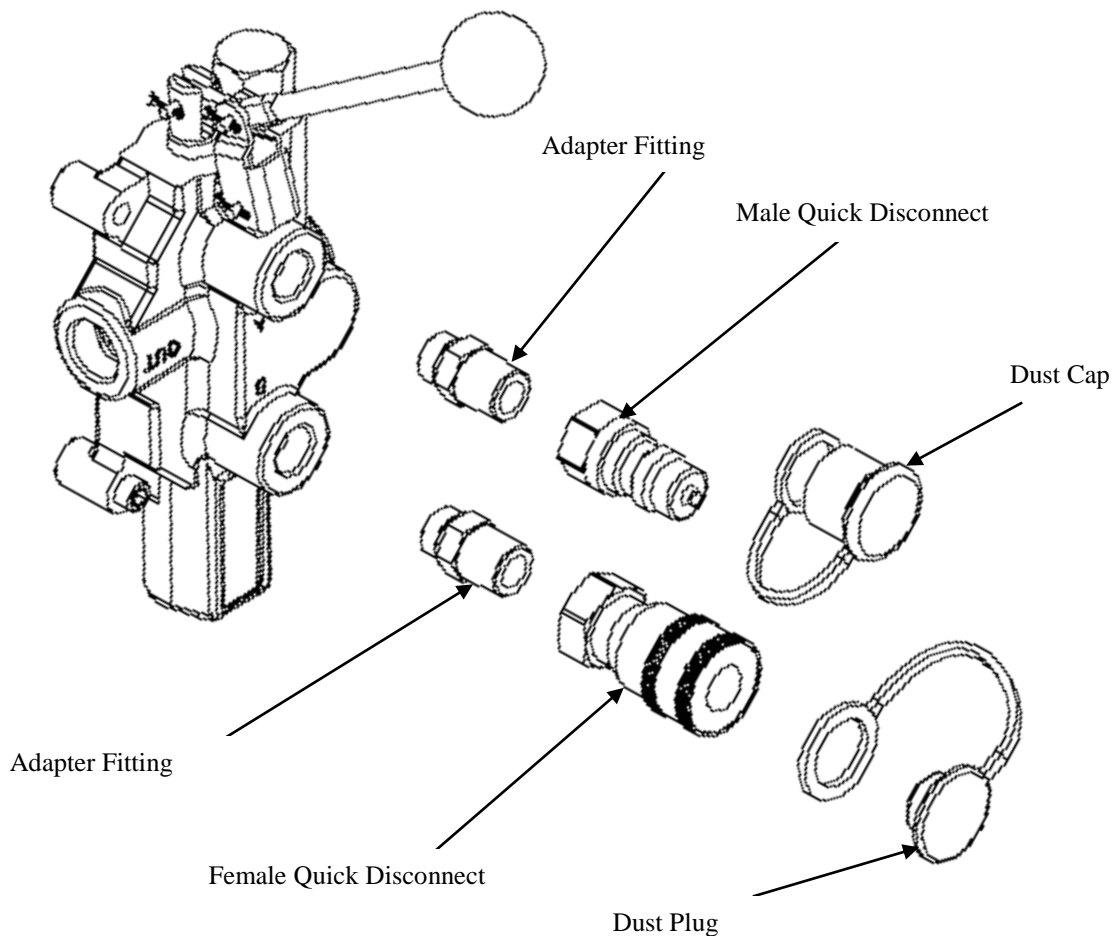

Limited Warranty

Dear Valued Customer:

The Brave product you just purchased is built with the finest material and craftsmanship. Use this product properly and enjoy the benefits from its high performance. By purchasing a Brave product, you show a desire for quality and durability. Like all mechanical equipment this unit requires a due amount of care. Treat this unit like the high quality piece of machinery it is. Neglect and improper handling may impair its performance.

Thoroughly read the instructions and understand the operation before using your product. Always contact Brave Product Support at 1-800-350-8739 prior to having any service or warranty work performed, as some services performed by parties other than Brave approved service centers may void this warranty. This limited warranty is in lieu of any other warranty expressed or implied, written or oral and Brave assumes no other responsibility or liability outside that expressed within this limited warranty.

Limited Warranty for Brave and Brave Pro Hydra Buddy Models:

1158284	1158285	1158286
1158287	1158288	1158289
1158290	1158292	1158293

	Consumer Warranty Period	Commercial Warranty Period
Weldments	2 years from date of purchase by user	2 year from date of purchase by user
Valves and Pumps	2 years from date of purchase by user	1 year from date of purchase by user
Wear Parts	In addition to the normal warranty, Brave shall warrant some normal wear items from defects in material or workmanship for a period of 30 days from the date of purchase by user. Normal wear items covered under this warranty are limited to: clamps, couplers, filters, mounts, hoses, hardware. Routine maintenance items such as lubricants, clutch adjustments, tune ups are not covered under warranty.	
Engines	The engine warranty is covered under the terms and conditions as outlined by the engine manufactures warranty contained herein and is the sole responsibility of the engine manufacturer. Normal engine maintenance such as spark plugs, oil changes, air filters, adjustments, fuel system cleaning and obstruction due to build up is not covered by this Brave limited warranty.	

“Consumer use” means personal residential household use by a consumer. “Commercial use” means all other uses, including, but not limited to, use for commercial, income producing or rental purposes or when purchased by a business.

This limited warranty applies to the original purchaser of the equipment (verification of purchase, in the form of a receipt, is the responsibility of the buyer), is non-transferable, and covers parts and labor. Parts will be replaced or repaired at no charge, except when the equipment has failed due to lack of proper maintenance. If a part is no longer available, the part may be replaced with a similar part of equal function. Any misuse, abuse, alteration or improper installation or operations will void warranty. Determining whether a part is to be replaced or repaired is the sole decision of Brave. Brave will not provide for replacement of complete products due to defective parts. Any costs incurred due to replacement or repair of items outside of a Brave approved facility is the responsibility of the buyer and not covered under warranty. Transportation costs to and from service center and/or service calls are the responsibility of the customer.

This limited warranty specifically excludes the following; failure of parts due to damage caused by accident, fire, flood, windstorm, acts of God, applications not approved by Brave in writing, corrosion caused by chemicals, use of replacement parts which do not conform to manufacturer’s specifications, damage related to rodent and/or insect infestation and damage caused by vandalism. Additional exclusions: loss of running time, inconvenience, loss of income, or loss of use, including any implied warranty of merchantability of fitness for a specific use. Also, outdoor power equipment needs periodic parts and service to perform well, and this limited warranty does not cover instances when normal use has exhausted the life of a component or the engine.

This limited warranty does not cover any personal injury or damage to surrounding property caused by failure of any part, misuse or inability to use the product. Alteration of the product, including safety features, shall void this limited warranty.

Repair or replacement of parts does not extend the warranty period. This limited warranty gives you specific legal rights. You may also have other rights that vary by state.

Please have model number, item number and serial number on hand prior to making a warranty claim or inquiry.

BRAVE ***HYDRA BUDDY™***

20195 S. Diamond Lake Rd, Ste 100
Rogers, MN 55374
1-800-350-8739